

***To open the menu  
please click on the icon  
near the top left  
of this page.***

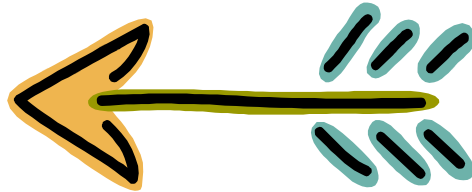

***To find keywords  
Enter the word in the “Find”  
Or “Search” box at the top.***

# GENERAL INFORMATION

**00**  
SECTION

00-00

## GENERAL INFORMATION . . . 00-00

### 00-00 GENERAL INFORMATION

<b>HOW TO USE THIS MANUAL</b> . . . . .	00-00-1	Dynamometer . . . . .	00-00-16
Range of Topics . . . . .	00-00-1	<b>INSTALLATION OF RADIO SYSTEM</b> . . . . .	00-00-16
Service Procedure . . . . .	00-00-2	<b>ELECTRICAL SYSTEM</b> . . . . .	00-00-16
Symbols . . . . .	00-00-3	Electrical Parts . . . . .	00-00-16
Advisory Messages . . . . .	00-00-4	Wiring Harness . . . . .	00-00-17
Troubleshooting Procedure . . . . .	00-00-5	Connectors . . . . .	00-00-17
Procedures for Use . . . . .	00-00-6	Terminals . . . . .	00-00-18
<b>UNITS</b> . . . . .	00-00-11	Sensors, Switches, and Relays . . . . .	00-00-19
Conversion to SI Units (Système International d'Unités) . . . . .	00-00-11	Wiring Harness . . . . .	00-00-19
Rounding Off . . . . .	00-00-11	Fuse . . . . .	00-00-19
Upper and Lower Limits . . . . .	00-00-11	Electrical Troubleshooting Tools . . . . .	00-00-20
<b>FUNDAMENTAL PROCEDURES</b> . . . . .	00-00-11	Precautions Before Welding . . . . .	00-00-20
Protection of the Vehicle . . . . .	00-00-11	<b>JACKING POSITIONS</b> . . . . .	00-00-21
Preparation of Tools and Measuring Equipment . . . . .	00-00-12	Front . . . . .	00-00-21
Special Service Tools . . . . .	00-00-12	Rear . . . . .	00-00-21
Oil Leakage Inspection . . . . .	00-00-12	<b>VEHICLE LIFT (2 SUPPORTS) AND SAFETY</b>	
Disconnection of the Negative Battery Cable . . . . .	00-00-13	<b>STAND (RIGID RACK) POSITION</b> . . . . .	00-00-22
Removal of Parts . . . . .	00-00-13	Vehicle Lift Positions . . . . .	00-00-22
Disassembly . . . . .	00-00-13	Safety Stand Positions . . . . .	00-00-22
Inspection During Removal, Disassembly . . . . .	00-00-13	<b>TOWING</b> . . . . .	00-00-22
Arrangement of Parts . . . . .	00-00-14	Tiedown Hooks . . . . .	00-00-23
Cleaning of Parts . . . . .	00-00-14	<b>IDENTIFICATION NUMBER LOCATIONS</b> 00-00-24	
Reassembly . . . . .	00-00-14	Vehicle Identification Number (VIN) . . . . .	00-00-24
Adjustment . . . . .	00-00-15	Chassis Number . . . . .	00-00-24
Rubber Parts and Tubing . . . . .	00-00-15	Engine Identification Number . . . . .	00-00-24
Hose Clamps . . . . .	00-00-15	<b>SAE STANDARDS</b> . . . . .	00-00-25
Torque Formulas . . . . .	00-00-15	<b>ABBREVIATIONS</b> . . . . .	00-00-26
Vise . . . . .	00-00-16	<b>PRE-DELIVERY INSPECTION</b> . . . . .	00-00-27
		Pre-Delivery Inspection Table . . . . .	00-00-27
		<b>SCHEDULED MAINTENANCE</b> . . . . .	00-00-29
		Scheduled Maintenance Table . . . . .	00-00-29

#### HOW TO USE THIS MANUAL

A3U000000001W01

##### Range of Topics

- This manual contains procedures for performing all required service operations. The procedures are divided into the following five basic operations:
  - Removal/Installation
  - Disassembly/Assembly
  - Replacement
  - Inspection
  - Adjustment
- Simple operations which can be performed easily just by looking at the vehicle (i.e., removal/installation of parts, jacking, vehicle lifting, cleaning of parts, and visual inspection) have been omitted.



# GENERAL INFORMATION

## Service Procedure

### Inspection, adjustment

- Inspection and adjustment procedures are divided into steps. Important points regarding the location and contents of the procedures are explained in detail and shown in the illustrations.

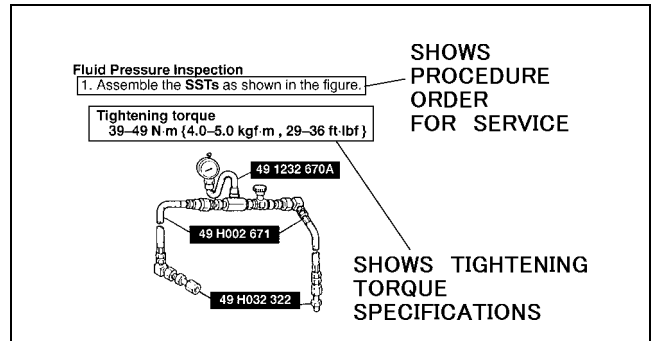

ZLU0000W208

# GENERAL INFORMATION

## Repair procedure

1. Most repair operations begin with an overview illustration. It identifies the components, shows how the parts fit together, and describes visual part inspection. However, only removal/installation procedures that need to be performed methodically have written instructions.
2. Expendable parts, tightening torques, and symbols for oil, grease, and sealant are shown in the overview illustration. In addition, symbols indicating parts requiring the use of special service tools or equivalent are also shown.
3. Procedure steps are numbered and the part that is the main point of that procedure is shown in the illustration with the corresponding number. Occasionally, there are important points or additional information concerning a procedure. Refer to this information when servicing the related part.

**SHOWS SERVICE ITEM(S)**

**Procedure**

**FRONT UPPER LINK, FRONT UPPER LEADING LINK REMOVAL/INSTALLATION**

**"Removal/Installation" Portion**

1. Jack up the front of the vehicle and support it with safety stands.
2. Remove the splash shield(s).  
(See 09-11-11 SPLASH SHIELD INSTALLATION.)
3. Remove in the order indicated in the table.
4. Install reverse order of removal.

**"Inspection After Installation" Portion**

5. Inspect the front wheel alignment and adjust it if necessary.

**INDICATES RELEVANT REFERENCES THAT NEED TO BE FOLLOWED DURING INSTALLATION**

**SHOWS SPECIAL SERVICE TOOL (SST) FOR SERVICE OPERATION**

**SHOWS APPLICATION POINTS OF GREASE, ETC.**

**SHOWS EXPENDABLE PARTS**

**SHOWS DETAILS**

**SHOWS TIGHTENING TORQUE SPECIFICATIONS**

**INSTALL THE PARTS BY PERFORMING STEPS 1-3 IN REVERSE ORDER**

**SHOWS PROCEDURE ORDER FOR SERVICE**

**SHOWS REFERRAL NOTES FOR SERVICE**

1	Split pin	5	Adjust cam bolt
2	Nut	6	Upper lateral link
3	Upper lateral link ball joint	7	Dust boot, clip (upper lateral link)
(See 02-13-6 Upper Lateral Link Ball Joint Removal Note)		8	Split pin
4	Cam nut, cam plate	9	Nut
		10	Upper leading link ball joint
		11	Upper leading link
		12	Dust boot (upper leading link)

**SHOWS REFERRAL NOTES FOR SERVICE**

**Upper Lateral Link Ball Joint Removal Note**

- Remove the ball joint using the SSTs.

**SHOWS SPECIAL SERVICE TOOL (SST) NO.**

49 T028 303

49 T028 304 UPPER LEADING LINK

49 T028 305 UPPER LATERAL LINK

**SHOWS TIGHTENING TORQUE UNITS**

N·m (kgf·m, ft·lbf)







YLU000WA0

## Symbols

- There are eight symbols indicating oil, grease, fluids, sealant, and the use of **SST** or equivalent. use. These symbols show application points or use of these materials during service.

Symbol	Meaning	Kind
	Apply oil	New appropriate engine oil or gear oil

## GENERAL INFORMATION

Symbol	Meaning	Kind
	Apply brake fluid	New appropriate brake fluid
	Apply automatic transaxle/ transmission fluid	New appropriate automatic transaxle/ transmission fluid
	Apply grease	Appropriate grease
	Apply sealant	Appropriate sealant
	Apply petroleum jelly	Appropriate petroleum jelly
	Replace part	O-ring, gasket, etc.
	Use SST or equivalent	Appropriate tools

### Advisory Messages

- You'll find several **Warnings, Cautions, Notes, Specifications** and **Upper and Lower Limits** in this manual.

### Warning

- A Warning indicates a situation in which serious injury or death could result if the warning is ignored.

### Caution

- A Caution indicates a situation in which damage to the vehicle or parts could result if the caution is ignored.

### Note

- A Note provides added information that will help you to complete a particular procedure.

### Specification

- The values indicate the allowable range when performing inspections or adjustments.

### Upper and lower limits

- The values indicate the upper and lower limits that must not be exceeded when performing inspections or adjustments.

## Troubleshooting Procedure Basic flow of troubleshooting

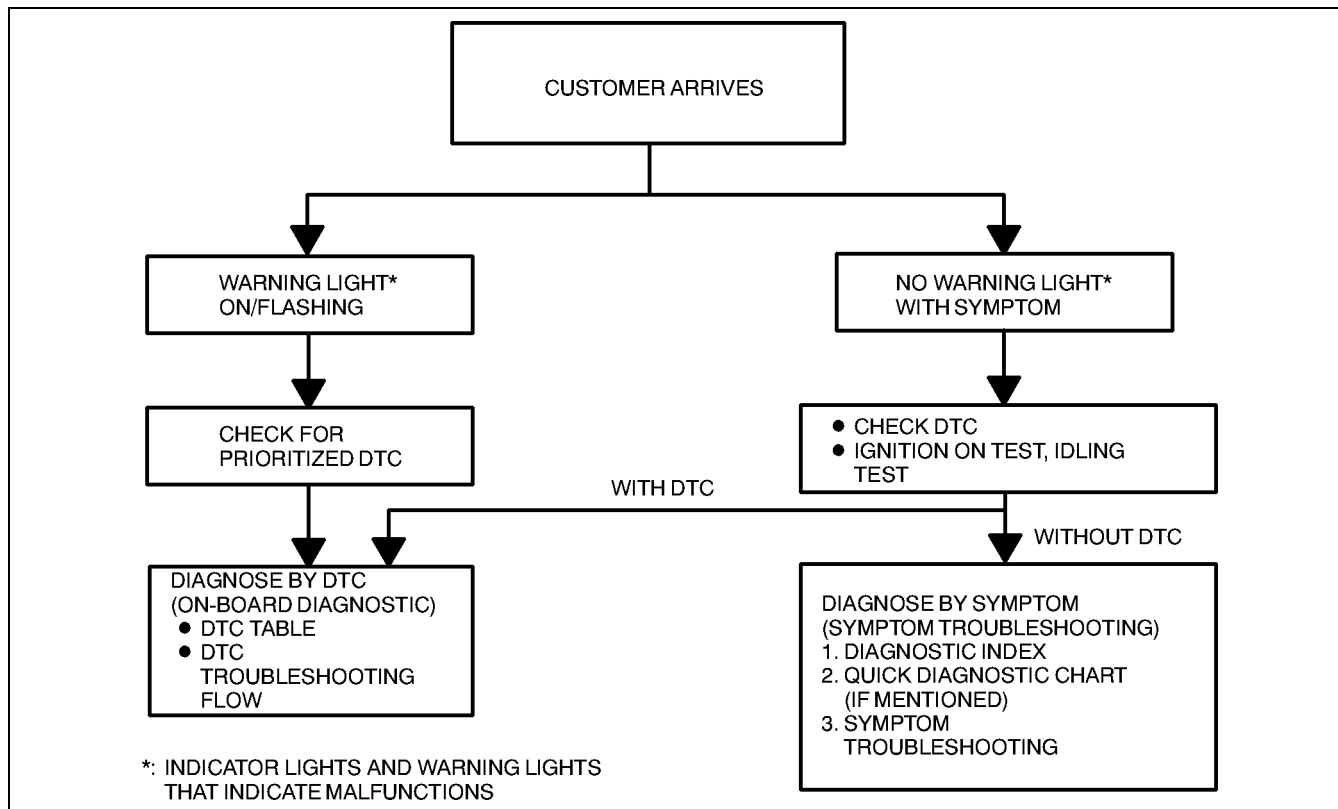

### DTC troubleshooting flow (on-board diagnostic)

- Diagnostic trouble codes (DTCs) are important hints for repairing malfunctions that are difficult to simulate. Perform the specific DTC diagnostic inspection to quickly and accurately diagnose the malfunction.
- The on-board diagnostic function is used during inspection. When a DTC is shown specifying the cause of a malfunction, continue the diagnostic inspection according to the items indicated by the on-board diagnostic function.

### Diagnostic index

- The diagnostic index lists the symptoms of specific malfunctions. Select the symptoms related or most closely relating to the malfunction.

### Quick diagnosis chart (If mentioned)

- The quick diagnosis chart lists diagnosis and inspection procedures to be performed specifically relating to the cause of the malfunction.

### Symptom troubleshooting

- Symptom troubleshooting quickly determines the location of the malfunction according to symptom type.

# GENERAL INFORMATION

## Procedures for Use

### Using the basic inspection (section 05)

- Perform the basic inspection procedure before symptom troubleshooting.
- Perform each step in the order shown.
- The reference column lists the location of the detailed procedure for each basic inspection.
- Although inspections and adjustments are performed according to the reference column procedures, if the cause of the malfunction is discovered during basic inspection, continue the procedures as indicated in the remarks column.

	SHOWS INSPECTION ORDER	SHOWS ITEM NAMES FOR DETAILED PROCEDURES	SHOW POINTS REQUIRING ATTENTION BASED ON INSPECTION RESULTS				
	<b>AUTOMATIC TRANSAXLE BASIC INSPECTION</b>						
	<b>STEP</b>	<b>INSPECTION</b>	<b>ACTION</b>				
	1	<ul style="list-style-type: none"> <li>• Turn ignition switch to ON position.</li> <li>• Does O/D OFF indicator light (illuminate/go out) correspond to O/D OFF switch position (on/off)?</li> </ul>	<table border="1" style="width: 100%; border-collapse: collapse;"> <tr> <td style="width: 10%; text-align: center;">Yes</td> <td>Go to next step.</td> </tr> <tr> <td style="width: 10%; text-align: center;">No</td> <td>Perform symptom troubleshooting No.26 "O/D OFF indicator light does not illuminate when O/D OFF switch is turned to on", or No.27 "O/D OFF indicator light illuminates when O/D OFF switch is not turned to on".</td> </tr> </table>	Yes	Go to next step.	No	Perform symptom troubleshooting No.26 "O/D OFF indicator light does not illuminate when O/D OFF switch is turned to on", or No.27 "O/D OFF indicator light illuminates when O/D OFF switch is not turned to on".
Yes	Go to next step.						
No	Perform symptom troubleshooting No.26 "O/D OFF indicator light does not illuminate when O/D OFF switch is turned to on", or No.27 "O/D OFF indicator light illuminates when O/D OFF switch is not turned to on".						
	2	<ul style="list-style-type: none"> <li>• Turn ignition switch to ON position.</li> <li>• When selector lever is moved, are selector lever position and indicator aligned? Also, when other ranges are selected from N or P during idling, does vehicle creep within 1 to 2 seconds?</li> </ul>	<table border="1" style="width: 100%; border-collapse: collapse;"> <tr> <td style="width: 10%; text-align: center;">Yes</td> <td>Go to next step.</td> </tr> <tr> <td style="width: 10%; text-align: center;">No</td> <td>Inspect selector lever.  Repair or replace defective areas.</td> </tr> </table>	Yes	Go to next step.	No	Inspect selector lever.  Repair or replace defective areas.
Yes	Go to next step.						
No	Inspect selector lever.  Repair or replace defective areas.						
	3	<ul style="list-style-type: none"> <li>• Inspect the ATF color condition. (See 05-17-8 Automatic Transaxle Fluid (ATF) Condition Inspection)</li> <li>• Are ATF color and odor normal?</li> </ul>	<table border="1" style="width: 100%; border-collapse: collapse;"> <tr> <td style="width: 10%; text-align: center;">Yes</td> <td>Go to next step.</td> </tr> <tr> <td style="width: 10%; text-align: center;">No</td> <td>Repair or replace any defective parts according to inspection result. Flush ATX and cooler line as necessary.</td> </tr> </table>	Yes	Go to next step.	No	Repair or replace any defective parts according to inspection result. Flush ATX and cooler line as necessary.
Yes	Go to next step.						
No	Repair or replace any defective parts according to inspection result. Flush ATX and cooler line as necessary.						
<b>REFERENCE COLUMN</b>	4	<ul style="list-style-type: none"> <li>• Perform line pressure test. (See 05-17-2 Line Pressure Test)</li> <li>• Is line pressure okay?</li> </ul>	<table border="1" style="width: 100%; border-collapse: collapse;"> <tr> <td style="width: 10%; text-align: center;">Yes</td> <td>Go to next step.</td> </tr> <tr> <td style="width: 10%; text-align: center;">No</td> <td>Adjust accelerator cable as necessary. Repair or replace any defective parts according to inspection result.</td> </tr> </table>	Yes	Go to next step.	No	Adjust accelerator cable as necessary. Repair or replace any defective parts according to inspection result.
Yes	Go to next step.						
No	Adjust accelerator cable as necessary. Repair or replace any defective parts according to inspection result.						
	5	<ul style="list-style-type: none"> <li>• Perform stall test.</li> <li>• Is stall speed is okay?</li> </ul>	<table border="1" style="width: 100%; border-collapse: collapse;"> <tr> <td style="width: 10%; text-align: center;">Yes</td> <td>Go to next step.</td> </tr> <tr> <td style="width: 10%; text-align: center;">No</td> <td>Repair or replace defective parts according to inspection result.</td> </tr> </table>	Yes	Go to next step.	No	Repair or replace defective parts according to inspection result.
Yes	Go to next step.						
No	Repair or replace defective parts according to inspection result.						

YLU000WA8

# GENERAL INFORMATION

## Using the DTC troubleshooting flow

- DTC troubleshooting flow shows diagnostic procedures, inspection methods, and proper action to take for each DTC.

DETECTION CONDITION describes the condition under which the DTC is detected.

TROUBLE CONDITION

DTC P0103
YMU102WAA

<b>DTC P0103</b>	<b>MAF circuit high input</b> PCM monitors input voltage from TP sensor after ignition key is turned on. If input voltage at PCM terminal 68 is above 8.25 V, PCM determines that TP circuit has a malfunction.	
<b>DETECTION CONDITION</b>	<b>Diagnostic support note</b> <ul style="list-style-type: none"> <li>This is a continuous monitor (CCM).</li> <li>MIL illuminates if PCM detects the above malfunction condition during first drive cycle. Therefore, PENDING CODE is not available.</li> <li>FREEZE FRAME DATA is available.</li> <li>DTC is stored in the PCM memory.</li> </ul>	
<b>POSSIBLE CAUSE describes possible point(s) of malfunction.</b>	<b>POSSIBLE CAUSE</b> <ul style="list-style-type: none"> <li>MAF sensor malfunction</li> <li>Connector or terminal malfunction</li> <li>Open circuit in wiring between MAF sensor terminal D and PCM terminal 36</li> <li>Open circuit in MAF sensor ground circuit</li> </ul>	

MAF SENSOR  
HARNESS SIDE CONNECTOR  
(VIEW FROM TERMINAL SIDE)

PCM  
HARNESS SIDE CONNECTOR  
(VIEW FROM HARNESS SIDE)

**Indicates the inspection step No. to be performed (section 01 and 05)**

**Indicates the circuit to be inspected (section 01 and 05)**

**Indicates the connector related to the inspection**

**STEP shows the order of troubleshooting**

**INSPECTION describes the method to quickly determine the failed part(s).**

STEP	INSPECTION		ACTION
1	<b>VERIFY FREEZE FRAME DATA HAS BEEN RECORDED</b> <ul style="list-style-type: none"> <li>Has FREEZE FRAME DATA been recorded?</li> </ul>	Yes	Go to next step.
		No	Record FREEZE FRAME DATA on repair order, then go to next step.
2	<b>VERIFY RELATED REPAIR INFORMATION AVAILABILITY</b> <ul style="list-style-type: none"> <li>Are related Service Bulletins and/or on-line repair information available?</li> </ul>	Yes	Perform repair or diagnosis according to available repair information. If vehicle is not repaired, then go to next step.
		No	Go to next step.
3	<b>VERIFY CURRENT INPUT SIGNAL STATUS IS CONCERN INTERMITTENT OR CONSTANT</b> <ul style="list-style-type: none"> <li>Connect NGS tester to DLC-2.</li> <li>Start engine.</li> <li>Access MAF V PID using NGS tester.</li> <li>Is MAF V PID within 0.2 – 8.3 V?</li> </ul>	Yes	Intermittent concern is existing. Go to INTERMITTENT CONCERNS TROUBLESHOOTING procedure. (See 01-03-33 INTERMITTENT CONCERN TROUBLESHOOTING)
		No	Go to next step.
4	<b>INSPECT POOR CONNECTION OF MAF SENSOR CONNECTOR</b> <ul style="list-style-type: none"> <li>Turn ignition key to OFF.</li> <li>Disconnect MAF sensor connector.</li> <li>Check for poor connection (damaged, pulled-out terminals, corrosion etc.).</li> <li>Are there any malfunctions?</li> </ul>	Yes	Repair or replace terminals, then go to Step 8.

**ACTION describes the appropriate action to take as according to the result (Yes/No).**

**Reference item(s) to perform ACTION**

YLU000WA1

## GENERAL INFORMATION

### Using the diagnostic index

- The symptoms of the malfunctions are listed in the diagnostic index for symptom troubleshooting.
- The exact malfunction symptoms can be selected by following the index.

NO.	TROUBLESHOOTING ITEM	DESCRIPTION	PAGE
1	Melts main or other fuse		(See 01-03-6 MELT NO.1 MAIN OR OTHER FUSE)
2	MIL comes on	MIL is illuminated incorrectly.	(See 01-03-7 NO.2 MIL COMES ON)
3	Will not crank	Starter does not work.	(See 01-03-8 NO.3 WILL NOT CRANK)
4	Hard start/long crank/erratic crank	Starter cranks engine at normal speed but engine requires excessive cranking time before starting.	(See 01-03-9 NO.4 HARD START/LONG CRANK/ERRATIC CRANK)
5	Engine stalls After start/at idle	Engine stops unexpectedly at idel and/or after start.	(See 01-03-11 NO.5 ENGINE STALLS-AFTER START/AT IDLE)
6	Cranks normally but will not start	Starter cranks engine at normal speed but engine will not run.	(See 01-03-15 NO.5 CRANKS NORMALLY BUT WILL NOT START)
7	Slow rerun to idle	Engine takes more time than normal to return to idle speed.	(See 01-03-19 NO.7 SLOW RERUN TO IDLE)
8	Engine runs rough/rolling idle	Engine speed fluctuates between specified idle speed and lower speed and engine shakes excessively.	(See 01-03-20 NO.8 ENGINE RUNS ROUGH/ROLLING IDLE)
9	Fast idle/runs on	Engine speed continues at fast idle after warm-up. Engine runs after ignition switch is turned off.	(See 01-03-23 NO.9 FAST IDLE/RUNS ON)
10	Low idle/stalls during deceleration	Engine stops unexpectedly at beginning of deceleration or recovery from deceleration.	(01-03-24 NO.10 LOW IDLE/STALLS DURING DECELERATION)

YLU000WA9

# GENERAL INFORMATION

## Using the quick diagnosis chart

- The chart lists the relation between the symptom and the cause of the malfunction.
- The chart is effective in quickly narrowing down the relation between symptom and cause of the malfunction. It also specifies the area of the common cause when multiple malfunction symptoms occur.
- The appropriate diagnostic inspection relating to malfunction cause as specified by the symptoms can be selected by looking down the diagnostic inspection column of the chart.

00-00

**② PARTS WHICH MAY BE THE CAUSE OF PROBLEMS**

**SYMPTOM QUICK DIAGNOSTIC CHART**

Troubleshooting item		Possible factor																					
		Starter motor malfunction (Mechanical or electrical)	Starter circuit including ignition switch open	Improper engine oil level	Low or dead battery	Charging system malfunction	Improper engine compression	Improper valve timing	Hydrolocked engine	Improper engine oil viscosity	Improper dipstick	Base engine malfunction	Drive plate or flywheel seized	Improper tension or damaged drive belts	Improper engine coolant level	Water and anti-freeze mixture improperly	Cooling system malfunction (Radiator, hoses, overflow system, thermostat, etc.)	Cooling fan system malfunction	Engine or transaxle mounts improperly installed	Cooling fan or condenser fan seat improperly	Accelerator cable free play mis-adjustment	Fuel quality	
1	Melts main or other fuse																						
2	MIL comes on																						
3	Will not crank	x	x		x	x																	
4	Hard start / long crank / erratic start / erratic crank																						x
5	Engine stalls After start / at idle										x	x	x										x
6	Cranks normally but will not start										x	x	x										x
7	Slow return to idle																						
8	Engine runs rough / rolling idle										x	x											x
9	Fast idle / runs on																						x
10	Low idle / stalls during deceleration																						
11	Engine stalls / quits Acceleration / cruise										x	x											x
	Engine runs rough Acceleration / cruise										x	x											x
	Misses Acceleration / cruise										x	x											x
	Buck / jerk Acceleration / cruise / deceleration										x	x											x
	Hesitation / stumble Acceleration										x	x											x
12	Lack / loss of power Acceleration / cruise										x	x											x
13	Knocking / pinging Acceleration / cruise										x												
14	Poor fuel economy										x	x				x		x		x			x
15	Emissions compliance										x	x											
16	High oil consumption/leakage																						
17	Cooling system concerns Overheating															x	x	x	x	x			
18	Cooling system concerns Runs cold																				x	x	
19	Exhaust smoke																						
20	Fuel odor (in engine compartment)																						
21	Engine noise																						
22	Vibration concerns (engine)																						
23	A/C does not work sufficiently																						
24	A/C always on / A/C compressor runs continuously																						
25	A/C does not cut off under wide open throttle conditions																						
26	Exhaust sulphur smell																						x
27	Fuel refill concerns																						
28	Fuel filling shut off issues																						
29	Intermittent concerns																						
30	Constant voltage																						
31	Spark plug condition																						
32	Automatic transaxle Upshift / downshift / engagement concerns																						

(See 05-01 AUTOMATIC TRANSAXLE SYMPTOM TROUBLESHOOTING)

**① CHOOSE THE ACTUAL SYMPTOM**

**PART WHICH MAY BE THE SYMPTOM**

YLU000WAA



# GENERAL INFORMATION

## Using the symptom troubleshooting

- Symptom troubleshooting shows diagnostic procedures, inspection methods, and proper action to take for each trouble symptom.

<p><b>DESCRIPTION</b> describes what kind of TROUBLE SYMPTOM.</p>	<p>14</p>	<p style="text-align: center;"><b>TRouble SYMPTOM</b></p> <p><b>Engine flares up or slips when upshifting or down shifting</b></p> <ul style="list-style-type: none"> <li>• When accelerator pedal is depressed for driveway, engine speed increase but vehicle speed increase slowly.</li> <li>• When accelerator is depressed while driving, engine speed increases but vehicle not.</li> </ul> <p><b>DESCRIPTION</b></p> <ul style="list-style-type: none"> <li>• There is clutch slip because clutch is stuck or line pressure is low.             <ul style="list-style-type: none"> <li>— Clutch stuck, slippage (forward clutch, 3-4 clutch, 2-4 brake band, one-way clutch 1, one-way clutch 2)                 <ul style="list-style-type: none"> <li>• Line pressure low</li> <li>• Malfunction or mis-adjustment of TP sensor</li> <li>• Malfunction of VSS</li> <li>• Malfunction of input/turbine speed sensor</li> <li>• Malfunction of sensor ground</li> <li>• Malfunction of shift solenoid A, B or C</li> <li>• Malfunction of TCC solenoid valve</li> <li>• Malfunction of body ground</li> <li>• Malfunction of throttle cable</li> <li>• Malfunction of throttle valve body</li> </ul> </li> <li>— Poor operating of mechanical pressure                 <ul style="list-style-type: none"> <li>• Selector lever position disparity</li> <li>• TR switch position disparity</li> </ul> </li> </ul> </li> </ul> <p><b>POSSIBLE CAUSE</b></p> <p><b>Note</b></p> <ul style="list-style-type: none"> <li>• Before following troubleshooting steps, make sure that Automatic Transaxle On-board Diagnostic and Automatic Transaxle Basic Inspection are conducted.</li> </ul>																																
<p><b>POSSIBLE CAUSE</b> describes possible point of malfunction.</p>																																		
<p><b>STEP</b> shows the order of troubleshooting.</p>																																		
<p><b>Reference item(s) for additional information to perform INSPECTION</b></p>																																		
<p><b>INSPECTION</b> describes the method to quickly determine the failed part.</p>																																		
<p><b>Diagnostic procedure</b></p>																																		
	<table border="1" style="width: 100%; border-collapse: collapse;"> <thead> <tr> <th style="width: 10%;">STEP</th> <th style="width: 40%;">INSPECTION</th> <th style="width: 10%;">Yes</th> <th style="width: 40%;">ACTION</th> </tr> </thead> <tbody> <tr> <td style="text-align: center;">1</td> <td> <ul style="list-style-type: none"> <li>• Is line pressure okay?</li> </ul> </td> <td style="text-align: center;">Yes</td> <td>Go to next step.</td> </tr> <tr> <td></td> <td></td> <td style="text-align: center;">No</td> <td>Repair or replace any defective parts according to inspection results.</td> </tr> <tr> <td style="text-align: center;">2</td> <td> <ul style="list-style-type: none"> <li>• Is shift point okay? (See 05-17-5 ROAD TEST)</li> </ul> </td> <td style="text-align: center;">Yes</td> <td>Go to next step.</td> </tr> <tr> <td></td> <td></td> <td style="text-align: center;">No</td> <td>Go to symptom troubleshooting No.9 "Abnormal shift".</td> </tr> <tr> <td style="text-align: center;">3</td> <td> <ul style="list-style-type: none"> <li>• Stop engine and turn ignition switch on.</li> <li>• Connect NGS tester to DLC-2.</li> <li>• Simulate SHIFT A, SHIFT B and SHIFT C PIDs for ON.</li> <li>• Is operating sound of shift solenoids heard?</li> </ul> </td> <td style="text-align: center;">Yes</td> <td> <ul style="list-style-type: none"> <li>• Overhaul control valve body and repair or replace any defective parts. (See ATX Workshop Manual GF4A-EL (9999-95-GF4A-00))</li> <li>• If problem remains, replace or overhaul transaxle and repair or replace defective parts. (See 05-17-15 AUTOMATIC TRANSAXLE REMOVAL/INSTALLATION)</li> </ul> </td> </tr> <tr> <td></td> <td></td> <td style="text-align: center;">No</td> <td> <ul style="list-style-type: none"> <li>• Inspect for bend, damage, corrosion or loose connection if shift solenoid A, B, or C terminal on ATX.</li> <li>• Inspect for shift solenoid mechanical stuck. (See 05-17-14 Inspection of Operation)</li> <li>• If shift solenoids are okay, inspect for open or short circuit between PCM connector terminal A, B or C.</li> </ul> </td> </tr> <tr> <td style="text-align: center;">4</td> <td> <ul style="list-style-type: none"> <li>• Verify test results.                             <ul style="list-style-type: none"> <li>— If okay, return to diagnostic index to service any additional symptoms.</li> <li>— If malfunction remains, inspect related Service Bulletins and/or On-line Repair Information and perform repair or diagnosis.</li> <li>— If vehicle is repaired, troubleshooting completed.</li> <li>— If vehicle is not repaired or additional diagnostic information is not available, replace or reprogram PCM.</li> </ul> </li> </ul> </td> <td></td> <td></td> </tr> </tbody> </table>	STEP	INSPECTION	Yes	ACTION	1	<ul style="list-style-type: none"> <li>• Is line pressure okay?</li> </ul>	Yes	Go to next step.			No	Repair or replace any defective parts according to inspection results.	2	<ul style="list-style-type: none"> <li>• Is shift point okay? (See 05-17-5 ROAD TEST)</li> </ul>	Yes	Go to next step.			No	Go to symptom troubleshooting No.9 "Abnormal shift".	3	<ul style="list-style-type: none"> <li>• Stop engine and turn ignition switch on.</li> <li>• Connect NGS tester to DLC-2.</li> <li>• Simulate SHIFT A, SHIFT B and SHIFT C PIDs for ON.</li> <li>• Is operating sound of shift solenoids heard?</li> </ul>	Yes	<ul style="list-style-type: none"> <li>• Overhaul control valve body and repair or replace any defective parts. (See ATX Workshop Manual GF4A-EL (9999-95-GF4A-00))</li> <li>• If problem remains, replace or overhaul transaxle and repair or replace defective parts. (See 05-17-15 AUTOMATIC TRANSAXLE REMOVAL/INSTALLATION)</li> </ul>			No	<ul style="list-style-type: none"> <li>• Inspect for bend, damage, corrosion or loose connection if shift solenoid A, B, or C terminal on ATX.</li> <li>• Inspect for shift solenoid mechanical stuck. (See 05-17-14 Inspection of Operation)</li> <li>• If shift solenoids are okay, inspect for open or short circuit between PCM connector terminal A, B or C.</li> </ul>	4	<ul style="list-style-type: none"> <li>• Verify test results.                             <ul style="list-style-type: none"> <li>— If okay, return to diagnostic index to service any additional symptoms.</li> <li>— If malfunction remains, inspect related Service Bulletins and/or On-line Repair Information and perform repair or diagnosis.</li> <li>— If vehicle is repaired, troubleshooting completed.</li> <li>— If vehicle is not repaired or additional diagnostic information is not available, replace or reprogram PCM.</li> </ul> </li> </ul>			<p><b>ACTION</b> describes the appropriate action to take as according to the result (Yes/No) of INSPECTION.</p> <p><b>How to perform ACTION</b> is described in the relative material shown.</p> <p><b>Reference item(s) to perform ACTION</b></p>
STEP	INSPECTION	Yes	ACTION																															
1	<ul style="list-style-type: none"> <li>• Is line pressure okay?</li> </ul>	Yes	Go to next step.																															
		No	Repair or replace any defective parts according to inspection results.																															
2	<ul style="list-style-type: none"> <li>• Is shift point okay? (See 05-17-5 ROAD TEST)</li> </ul>	Yes	Go to next step.																															
		No	Go to symptom troubleshooting No.9 "Abnormal shift".																															
3	<ul style="list-style-type: none"> <li>• Stop engine and turn ignition switch on.</li> <li>• Connect NGS tester to DLC-2.</li> <li>• Simulate SHIFT A, SHIFT B and SHIFT C PIDs for ON.</li> <li>• Is operating sound of shift solenoids heard?</li> </ul>	Yes	<ul style="list-style-type: none"> <li>• Overhaul control valve body and repair or replace any defective parts. (See ATX Workshop Manual GF4A-EL (9999-95-GF4A-00))</li> <li>• If problem remains, replace or overhaul transaxle and repair or replace defective parts. (See 05-17-15 AUTOMATIC TRANSAXLE REMOVAL/INSTALLATION)</li> </ul>																															
		No	<ul style="list-style-type: none"> <li>• Inspect for bend, damage, corrosion or loose connection if shift solenoid A, B, or C terminal on ATX.</li> <li>• Inspect for shift solenoid mechanical stuck. (See 05-17-14 Inspection of Operation)</li> <li>• If shift solenoids are okay, inspect for open or short circuit between PCM connector terminal A, B or C.</li> </ul>																															
4	<ul style="list-style-type: none"> <li>• Verify test results.                             <ul style="list-style-type: none"> <li>— If okay, return to diagnostic index to service any additional symptoms.</li> <li>— If malfunction remains, inspect related Service Bulletins and/or On-line Repair Information and perform repair or diagnosis.</li> <li>— If vehicle is repaired, troubleshooting completed.</li> <li>— If vehicle is not repaired or additional diagnostic information is not available, replace or reprogram PCM.</li> </ul> </li> </ul>																																	

YLU000WA2

# GENERAL INFORMATION

## UNITS

A3U00000002W01

Electric current	A (ampere)
Electric power	W (watt)
Electric resistance	$\Omega$ (ohm)
Electric voltage	V (volt)
Length	mm (millimeter)
	in (inch)
Negative pressure	kPa (kilo pascal)
	mmHg (millimeters of mercury)
	inHg (inches of mercury)
Positive pressure	kPa (kilo pascal)
	kgf/cm <sup>2</sup> (kilogram force per square centimeter)
	psi (pounds per square inch)
Number of revolutions	rpm (revolutions per minute)

Torque	N·m (Newton meter)
	kgf·m (kilogram force meter)
	kgf·cm (kilogram force centimeter)
	ft·lbf (foot pound force)
	in·lbf (inch pound force)
Volume	L (liter)
	US qt (U.S. quart)
	Imp qt (Imperial quart)
	ml (milliliter)
	cc (cubic centimeter)
	cu in (cubic inch)
Weight	fl oz (fluid ounce)
	g (gram)
	oz (ounce)

00-00

### Conversion to SI Units (Système International d'Unités)

- All numerical values in this manual are based on SI units. Numbers shown in conventional units are converted from these values.

### Rounding Off

- Converted values are rounded off to the same number of places as the SI unit value. For example, if the SI unit value is 17.2 and the value after conversion is 37.84, the converted value will be rounded off to 37.8.

### Upper and Lower Limits

- When the data indicates upper and lower limits, the converted values are rounded down if the SI unit value is an upper limit and rounded up if the SI unit value is a lower limit. Therefore, converted values for the same SI unit value may differ after conversion. For example, consider 2.7 kgf/cm<sup>2</sup> in the following specifications:

**210—260 kPa {2.1—2.7 kgf/cm<sup>2</sup>, 30—38 psi}**  
**270—310 kPa {2.7—3.2 kgf/cm<sup>2</sup>, 39—45 psi}**

- The actual converted values for 2.7 kgf/cm<sup>2</sup> are 264 kPa and 38.4 psi. In the first specification, 2.7 is used as an upper limit, so the converted values are rounded down to 260 and 38. In the second specification, 2.7 is used as a lower limit, so the converted values are rounded up to 270 and 39.

## FUNDAMENTAL PROCEDURES

A3U00000004W01

### Protection of the Vehicle

- Always be sure to cover fenders, seats and floor areas before starting work.

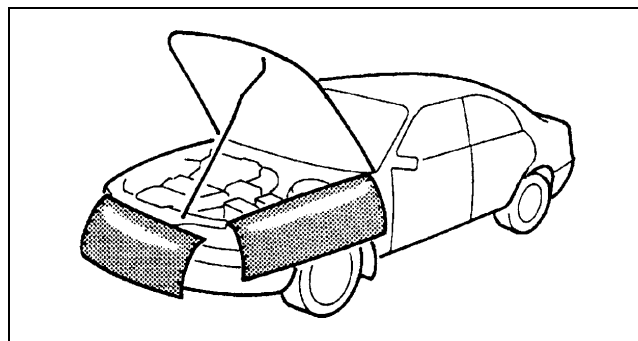

X3U000WAG

## GENERAL INFORMATION

### Preparation of Tools and Measuring Equipment

- Be sure that all necessary tools and measuring equipment are available before starting any work.

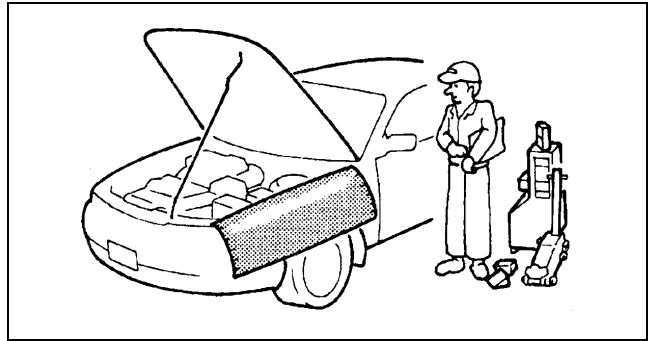

X3U000WAH

### Special Service Tools

- Use special service tools or equivalent when they are required.

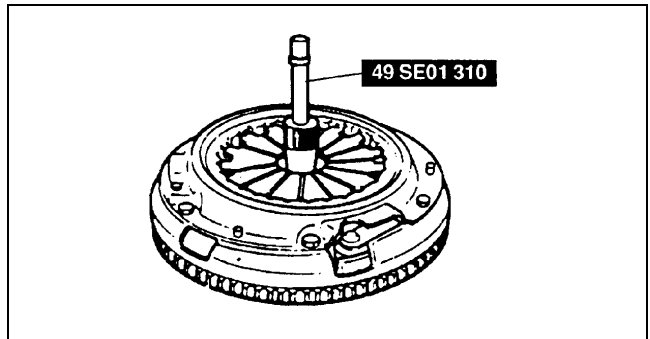

X3U000WAJ

### Oil Leakage Inspection

- Use either of the following procedures to identify the type of oil that is leaking:

#### Using UV light (black light)

1. Remove any oil on the engine or transaxle.

#### Note

- Referring to the fluorescent dye instruction manual, mix the specified amount of dye into the engine oil or ATF (or transaxle oil).

2. Pour the fluorescent dye into the engine oil or ATF (or transaxle oil).
3. Allow the engine to run for 30 minutes.
4. Inspect for dye leakage by irradiating with UV light (black light), and identify the type of oil that is leaking.
  - If no dye leakage is found, allow the engine to run for another 30 minutes or drive the vehicle then reinspect.
5. Find where the oil is leaking from, then make necessary repairs.

#### Note

- To determine whether it is necessary to replace the oil after adding the fluorescent dye, refer to the fluorescent dye instruction manual.

#### Not using UV light (black light)

1. Gather some of the leaking oil using an absorbent white tissue.
2. Take samples of engine oil and ATF (or transaxle oil), both from the dipstick, and place them next to the leaked oil already gathered on the tissue.

## GENERAL INFORMATION

3. Compare the appearance and smell, and identify the type of oil that is leaking.
4. Remove any oil on the engine or transaxle.
5. Allow the engine to run for 30 minutes.
6. Check the area where the oil is leaking, then make necessary repairs.

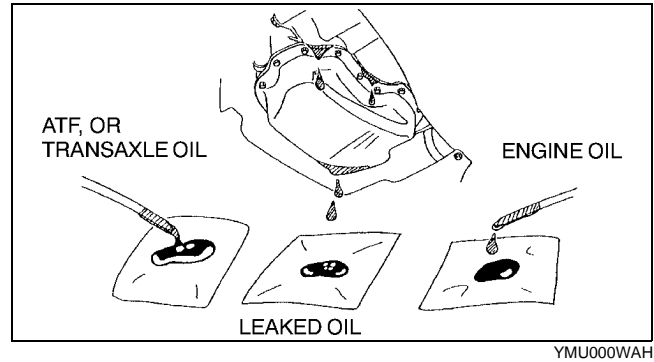

00-00

### Disconnection of the Negative Battery Cable

- Before beginning any work, turn the ignition switch to LOCK position, then disconnect the negative battery cable and wait for more than 1 minute to allow the backup power supply of the SAS control module to deplete its stored power. Disconnecting the battery cable will delete the memories of the clock, audio, and DTCs, etc. Therefore, it is necessary to verify those memories before disconnecting the cable.

### Removal of Parts

- While correcting a problem, also try to determine its cause. Begin work only after first learning which parts and subassemblies must be removed and disassembled for replacement or repair. After removing the part, plug all holes and ports to prevent foreign material from entering.

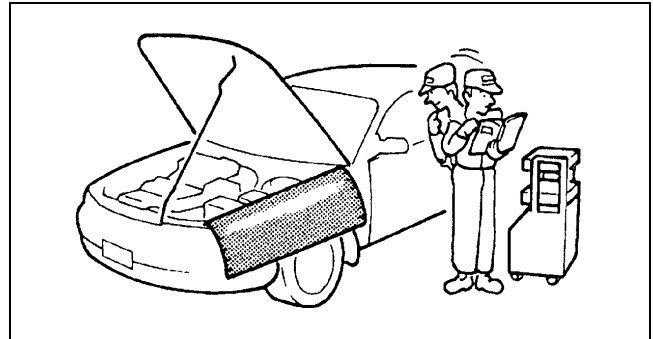

### Disassembly

- If the disassembly procedure is complex, requiring many parts to be disassembled, all parts should be marked in a place that will not affect their performance or external appearance and identified so that reassembly can be performed easily and efficiently.

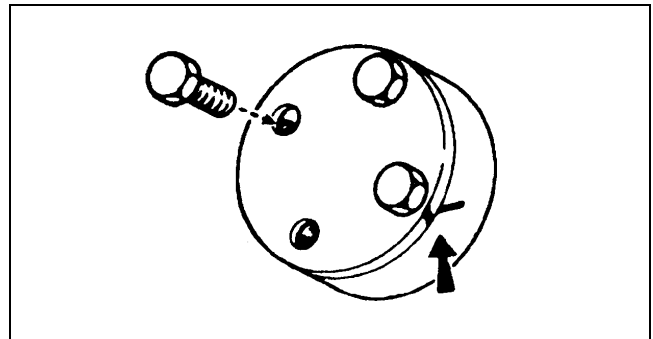

### Inspection During Removal, Disassembly

- When removed, each part should be carefully inspected for malfunction, deformation, damage, and other problems.

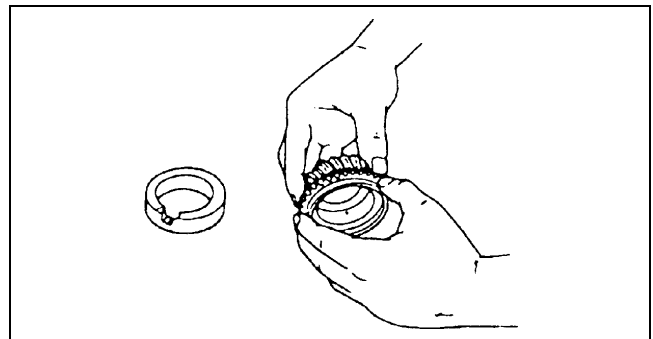

## GENERAL INFORMATION

### Arrangement of Parts

- All disassembled parts should be carefully arranged for reassembly.
- Be sure to separate or otherwise identify the parts to be replaced from those that will be reused.

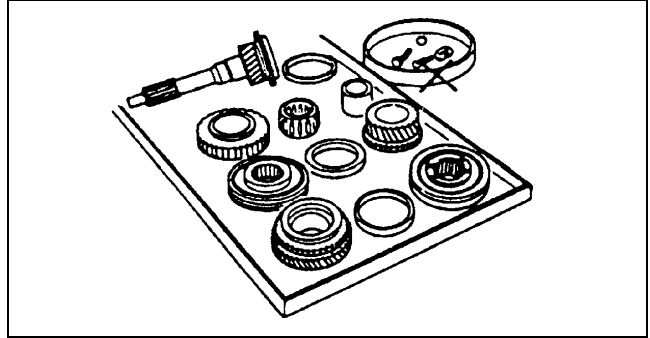

X3U000WAN

### Cleaning of Parts

- All parts to be reused should be carefully and thoroughly cleaned in the appropriate method.

#### Warning

- **Using compressed air can cause dirt and other particles to fly out causing injury to the eyes. Wear protective eye wear whenever using compressed air.**

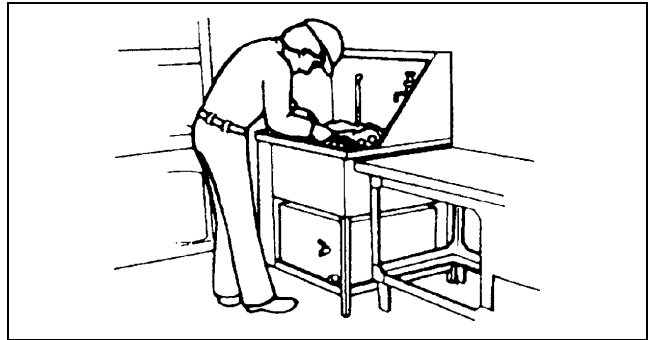

X3U000WAP

### Reassembly

- Standard values, such as torques and certain adjustments, must be strictly observed in the reassembly of all parts.
- If removed, these parts should be replaced with new ones:
  - Oil seals
  - Gaskets
  - O-rings
  - Lockwashers
  - Cotter pins
  - Nylon nuts
- Depending on location:
  - Sealant and gaskets, or both, should be applied to specified locations. When sealant is applied, parts should be installed before sealant hardens to prevent leakage.
  - Oil should be applied to the moving components of parts.
  - Specified oil or grease should be applied at the prescribed locations (such as oil seals) before reassembly.

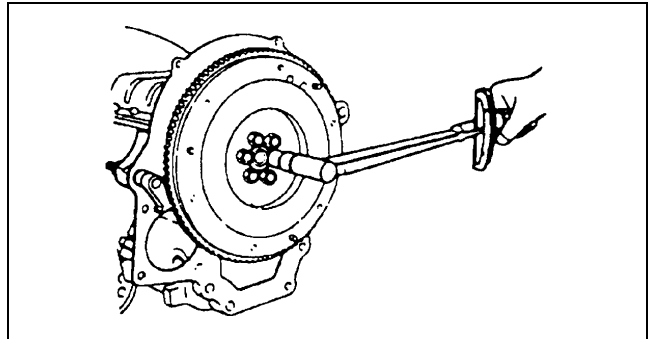

X3U000WAQ

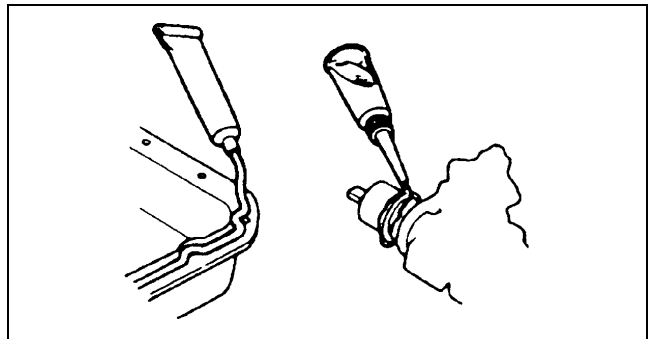

X3U000WAR

# GENERAL INFORMATION

## Adjustment

- Use suitable gauges and/or testers when making adjustments.

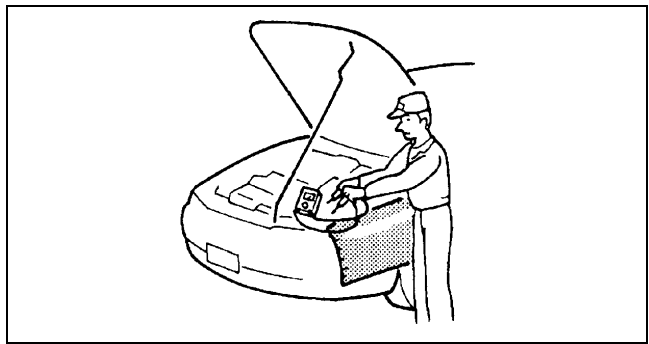

X3U000WAS

00-00

## Rubber Parts and Tubing

- Prevent gasoline or oil from getting on rubber parts or tubing.

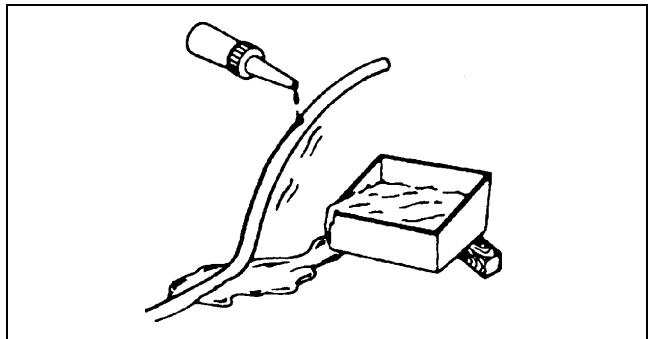

X3U000WAT

## Hose Clamps

- When reinstalling, position the hose clamp in the original location on the hose and squeeze the clamp lightly with large pliers to ensure a good fit.

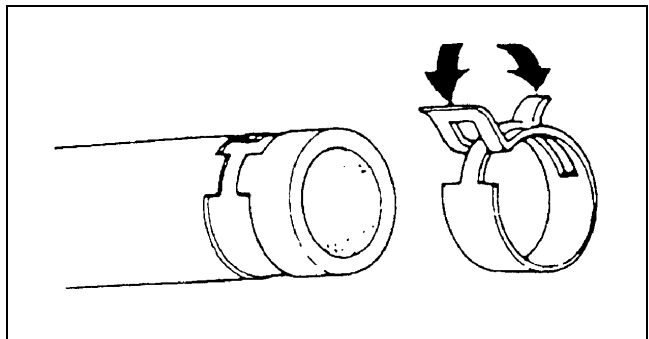

X3U000WAW

## Torque Formulas

- When using a torque wrench-SST or equivalent combination, the written torque must be recalculated due to the extra length that the SST or equivalent adds to the torque wrench. Recalculate the torque using the following formulas. Choose the formula that applies to you.

Torque Unit	Formula
N·m	$N \cdot m \times [L / (L + A)]$
kgf·m	$kgf \cdot m \times [L / (L + A)]$
kgf·cm	$kgf \cdot cm \times [L / (L + A)]$
ft·lbf	$ft \cdot lbf \times [L / (L + A)]$
in·lbf	$in \cdot lbf \times [L / (L + A)]$

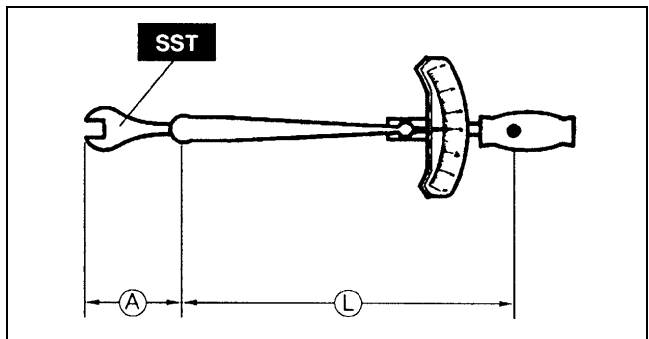

X3U000WAW

- A : The length of the SST past the torque wrench drive.
- L : The length of the torque wrench.

## GENERAL INFORMATION

### Vise

- When using a vise, put protective plates in the jaws of the vise to prevent damage to parts.

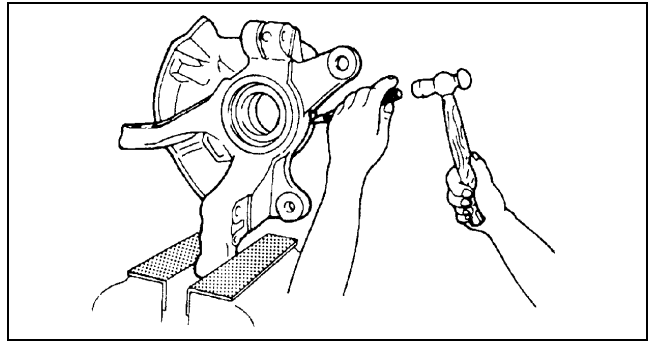

X3U000WAW

### Dynamometer

- When test-running a vehicle on a dynamometer:
  - Place a fan, preferably a vehicle-speed proportional type, in front of the vehicle.
  - Connect an exhaust gas ventilation unit.
  - Cool the exhaust pipes with a fan.
  - Keep the area around the vehicle uncluttered.
  - Watch the water temperature gauge.

### Note

- When the vehicle is on a chassis roller and only the front wheels rotate, the ABS warning light may illuminate. (Refer to 04-10-1 PRECAUTION (BRAKES) to turn off the warning light.)

## INSTALLATION OF RADIO SYSTEM

A3U00000005W01

If a radio system is installed improperly or if a high-powered type is used, the CIS and other systems may be affected. When the vehicle is to be equipped with a radio, observe the following precautions:

- Install the antenna at the farthest point from control modules.
- Install the antenna feeder as far as possible from the control module harnesses.
- Ensure that the antenna and feeder are properly adjusted.
- Do not install a high-powered radio system.

## ELECTRICAL SYSTEM

A3U00000006W01

### Electrical Parts

#### Battery cable

- Before disconnecting connectors or removing electrical parts, disconnect the negative battery cable.

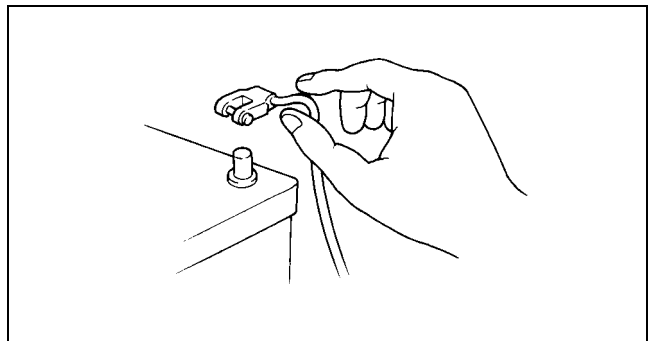

WGIWXX0038E

## GENERAL INFORMATION

### Wiring Harness

- To remove the wiring harness from the clip in the engine room, pry up the hook of the clip using a flathead screwdriver.

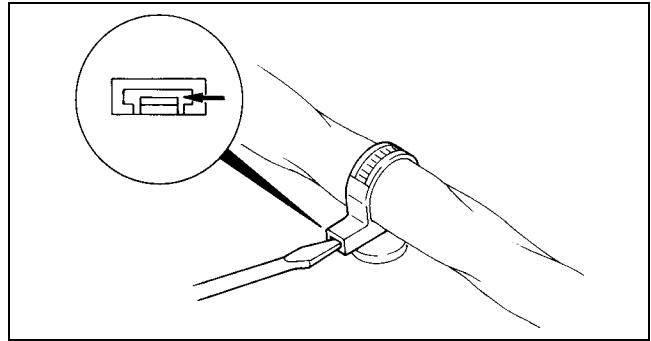

WGIWXX0039E

00-00

### Connectors

#### Disconnecting connectors

- When disconnecting connector, grasp the connectors, not the wires.

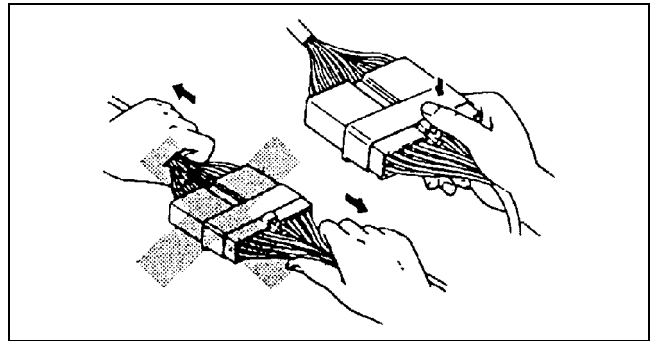

WGIWXX0041E

- Connectors can be disconnected by pressing or pulling the lock lever as shown.

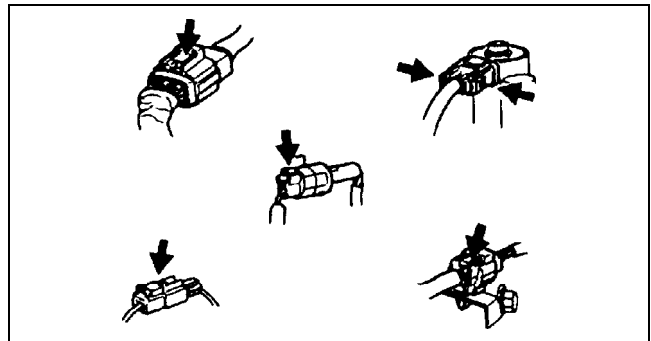

WGIWXX0042E

#### Locking connector

- When locking connectors, listen for a click indicating they are securely locked.

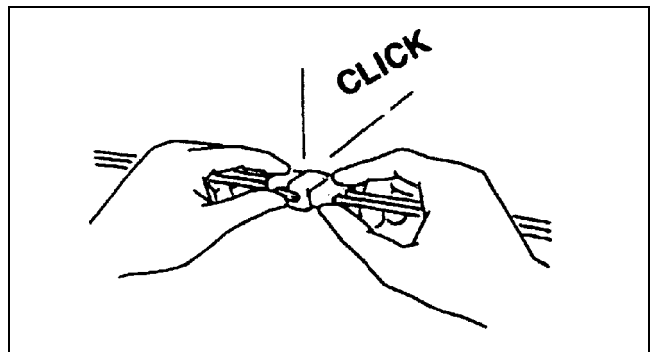

WGIWXX0043E



## GENERAL INFORMATION

### Inspection

- When a tester is used to inspect for continuity or measuring voltage, insert the tester probe from the wiring harness side.
- Inspect the terminals of waterproof connectors from the connector side since they cannot be accessed from the wiring harness side.

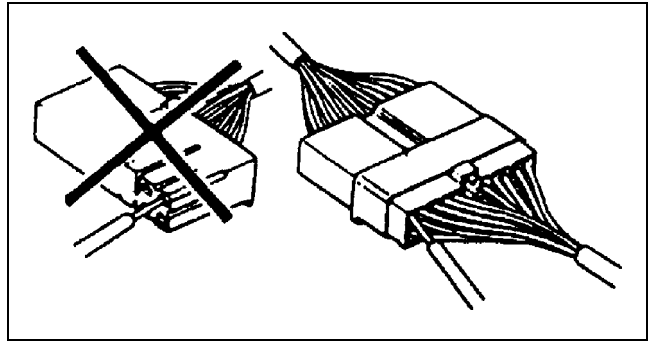

WGIWXX0044E

### Caution

- To prevent damage to the terminal, wrap a thin wire around the tester probe before inserting into terminal.

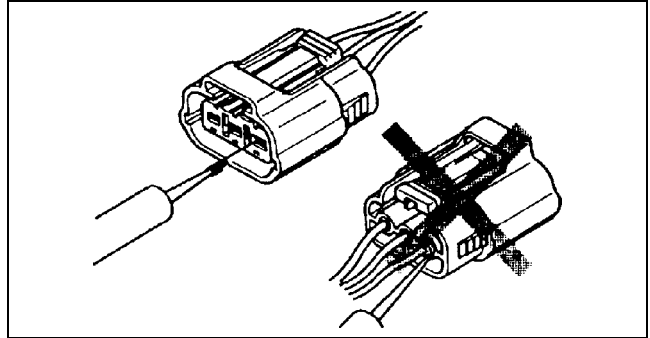

WGIWXX0045E

### Terminals Inspection

- Pull lightly on individual wires to verify that they are secured in the terminal.

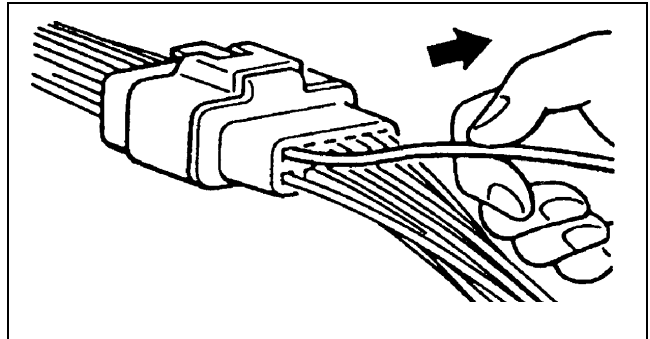

X3U000WB4

### Replacement

- Use the appropriate tools to remove a terminal as shown. When installing a terminal, be sure to insert it until it locks securely.
- Insert a thin piece of metal from the terminal side of the connector and with the terminal locking tab pressed down, pull the terminal out from the connector.

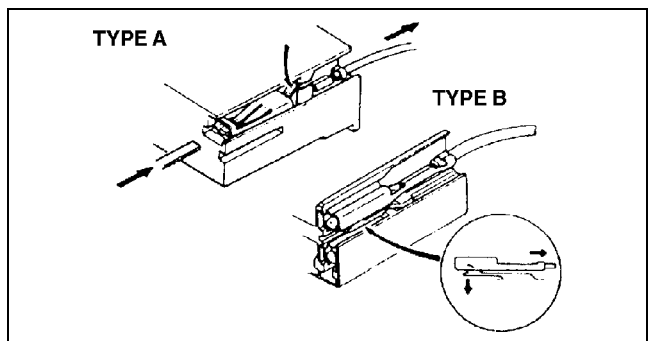

WGIWXX0046E

# GENERAL INFORMATION

## Sensors, Switches, and Relays

- Handle sensors, switches, and relays carefully. Do not drop them or strike them against other objects.

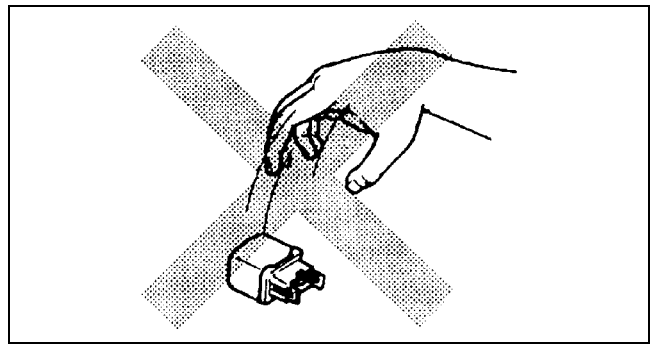

WGIWXX0047E

00-00

## Wiring Harness

### Wiring color codes

- Two-color wires are indicated by a two-color code symbol.
- The first letter indicates the base color of the wire and the second the color of the stripe.

CODE	COLOR	CODE	COLOR
B	Black	O	Orange
BR	Brown	P	Pink
G	Green	R	Red
GY	Gray	V	Violet
L	Blue	W	White
LB	Light Blue	Y	Yellow
LG	Light Green		

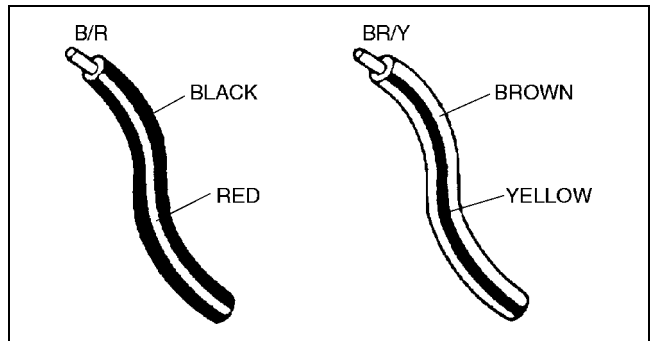

WGIWXX0048E

## Fuse

### Replacement

- When replacing a fuse, be sure to replace it with one of the same capacity. If a fuse fails again, the circuit probably has a short and the wiring should be inspected.
- Be sure the negative battery terminal is disconnected before replacing a main fuse.

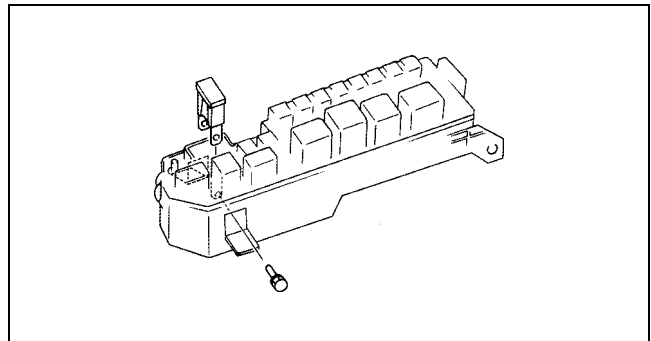

WGIWXX0049E

- When replacing a pullout fuse, use the fuse puller.

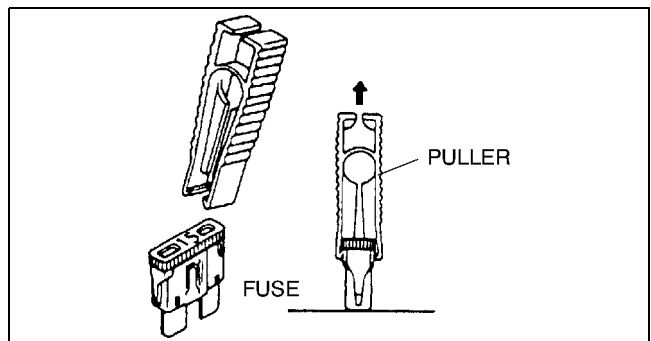

WGIWXX0050E

## GENERAL INFORMATION

### Electrical Troubleshooting Tools

#### Jumper wire

- A jumper wire is used to create a temporary circuit. Connect the jumper wire between the terminals of a circuit to bypass a switch.

#### Caution

- **Do not connect a jumper wire from the power source line to a body ground. This may cause burning or other damage to wiring harnesses or electronic components.**

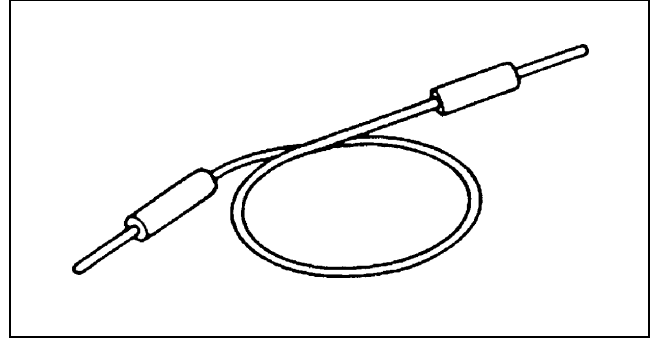

X3U000WBB

#### Voltmeter

- The DC voltmeter is used to measure circuit voltage. A voltmeter with a range of **15 V or more** is used by connecting the positive (+) probe (red lead wire) to the point where voltage will be measured and the negative (-) probe (black lead wire) to a body ground.

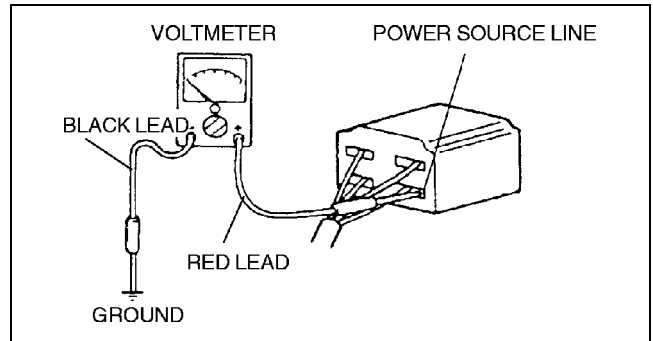

WGIWXX0051E

#### Ohmmeter

- The ohmmeter is used to measure the resistance between two points in a circuit and to inspect for continuity and short circuits.

#### Caution

- **Do not connect the ohmmeter to any circuit where voltage is applied. This will damage the ohmmeter.**

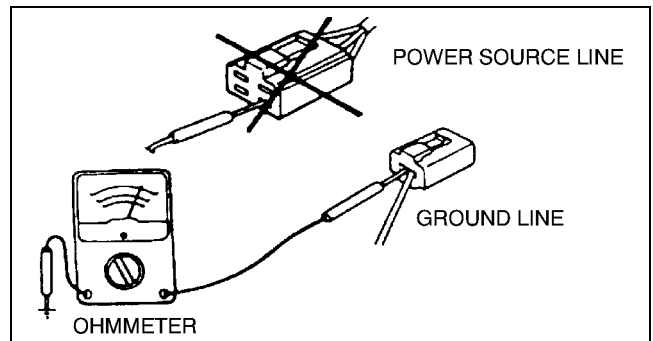

WGIWXX0052E

#### Precautions Before Welding

A vehicle has various electrical parts. To protect the parts from excessive current generated when welding, be sure to perform the following procedure.

1. Turn the ignition switch to the LOCK position.

## GENERAL INFORMATION

2. Disconnect the battery cables.

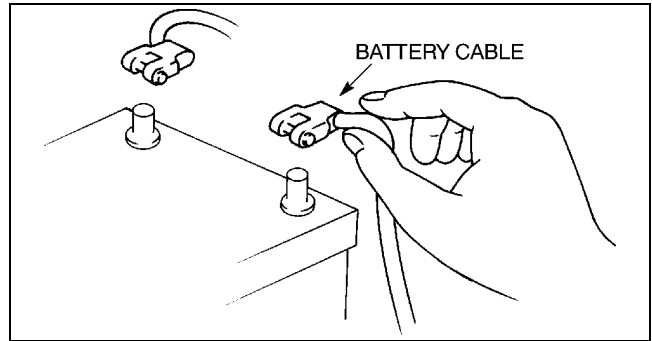

WGIWXX0007E

3. Securely connect the welding machine ground near the welding area.
4. Cover the peripheral parts of the welding area to protect them from weld spatter.

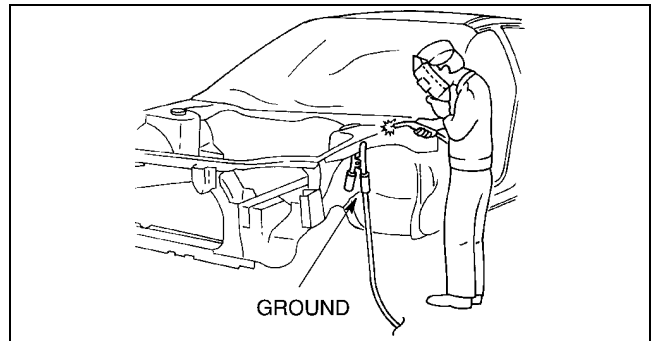

WGIWXX0008E

## JACKING POSITIONS

A3U00000007W01

### Warning

- **Improperly jacking a vehicle is dangerous. The vehicle can slip off the jack and cause serious injury. Use only the correct front and rear jacking positions and block the wheels.**
- Use safety stands to support the vehicle after it has been lifted.

### Front

- At the center of the crossmember

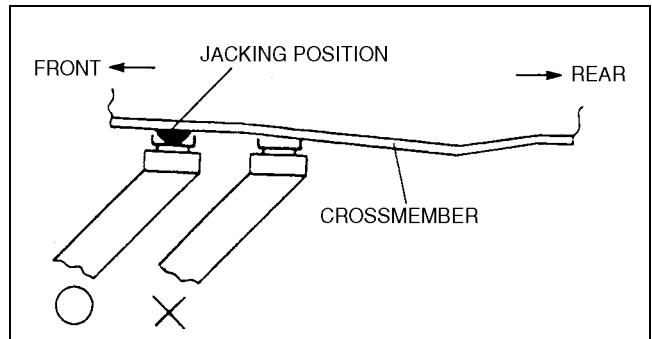

WGIWXX0006E

### Rear

- At the center of the crossmember

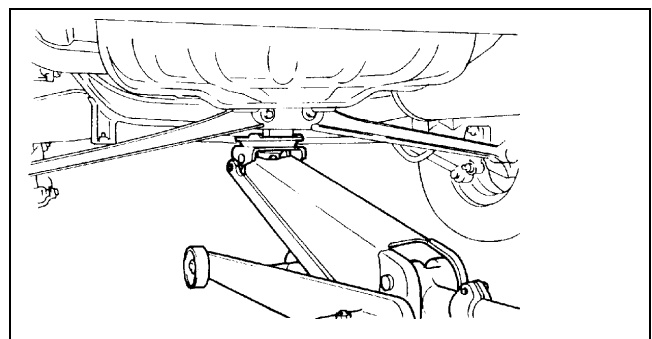

X3U000WBF

# GENERAL INFORMATION

## VEHICLE LIFT (2 SUPPORTS) AND SAFETY STAND (RIGID RACK) POSITION

A3U00000008W01

### Vehicle Lift Positions

#### Front and rear

#### Warning

- Unstably lifting a vehicle is dangerous. The vehicle can slip off the lift and cause serious injury and/or vehicle damage. Make sure that the vehicle is on the lift horizontally by adjusting the height of support at the end of the arm of the lift.

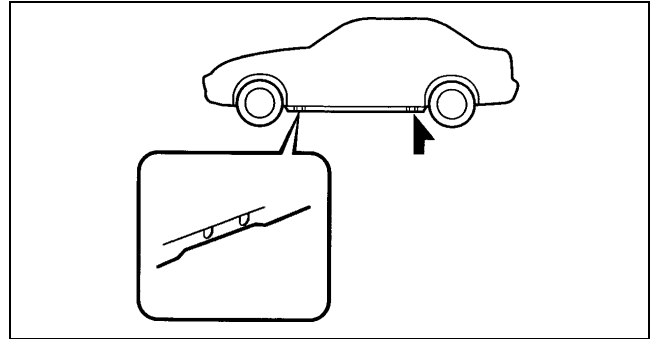

X3U000WBH

### Safety Stand Positions

#### Front

- Both sides of the vehicle, on side sills.

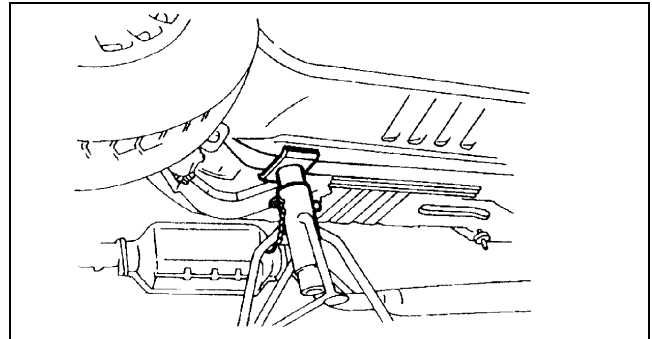

X3U000WBJ

#### Rear

- Both sides of the vehicle, on side sills.

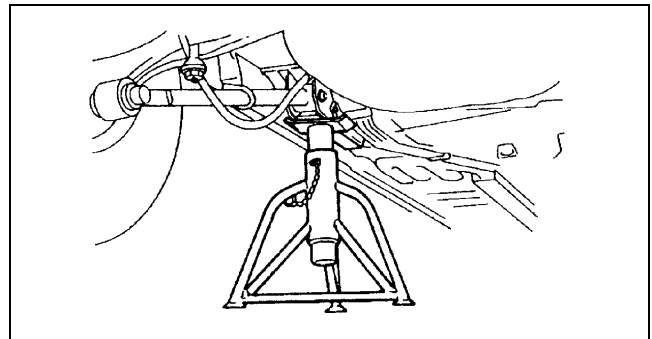

X3U000WBK

## TOWING

A3U00000009W01

- Proper lifting and towing are necessary to prevent damage to the vehicle. State and local laws must be followed.
- A towed vehicle usually should have its front wheels off the ground. If excessive damage or other conditions prevent this, use wheel dollies.

## GENERAL INFORMATION

- When towing with the rear wheels on the ground, release the parking brake.

### Caution

- Do not tow with sling-type equipment. This could damage your vehicle. Use wheel-lift or flatbed equipment.

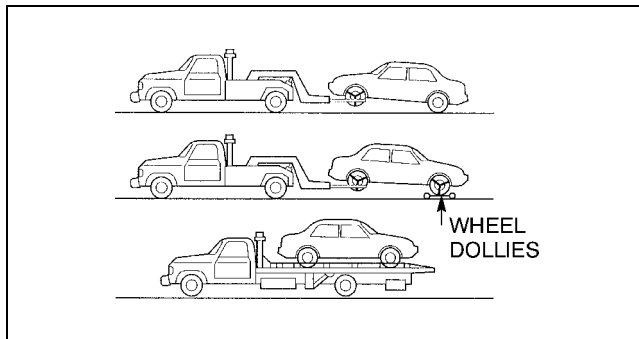

YLU000WA5

00-00

### Caution

- Do not tow the vehicle backward with driving wheels on the ground. This may cause internal damage to the transaxle.

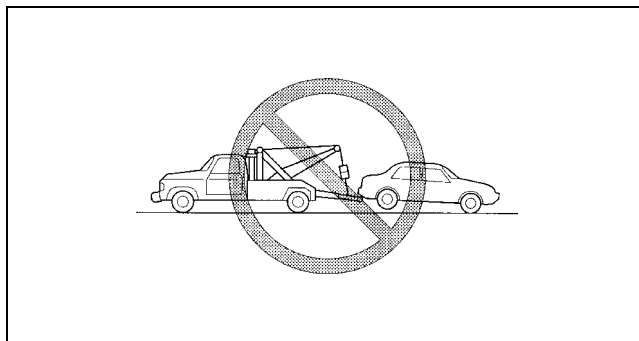

YLU000WA7

### Caution

- Do not use the hook loops under the front and rear for towing. They are designed ONLY for tying down the vehicle when it is being transported. Using them for towing will damage the bumper.

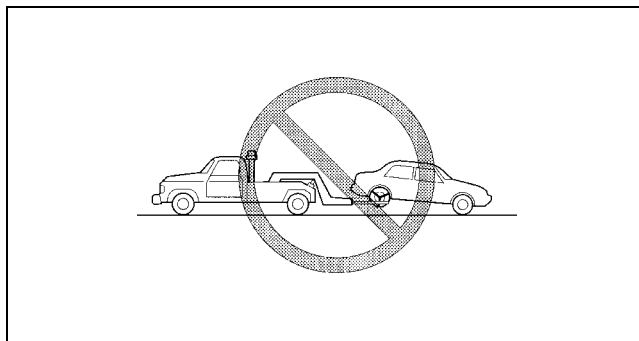

YLU000WA6

### Tiedown Hooks Front

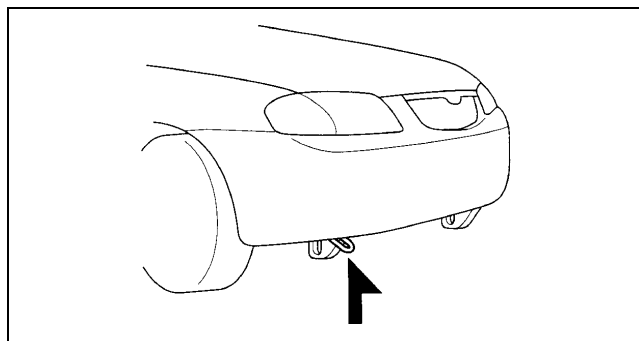

X3U000WBP

# GENERAL INFORMATION

Rear

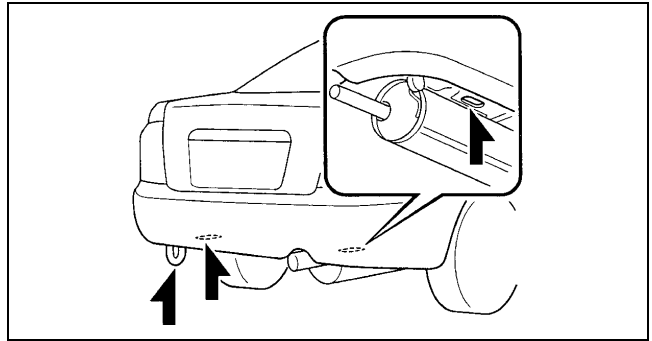

X3U000WBQ

## IDENTIFICATION NUMBER LOCATIONS

Vehicle Identification Number (VIN)

A3U000000010W01

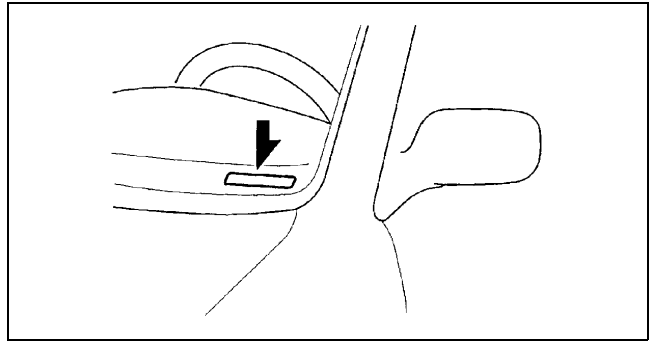

X3U000WBV

Chassis Number

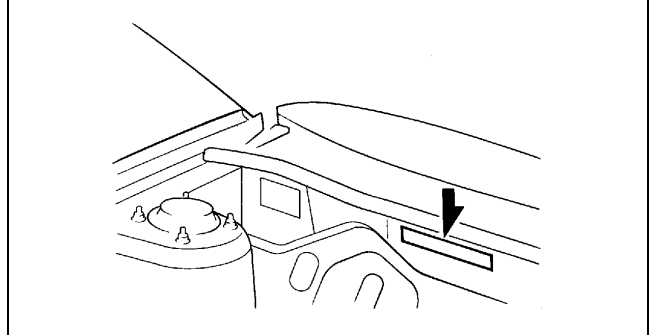

X3U000WBR

Engine Identification Number

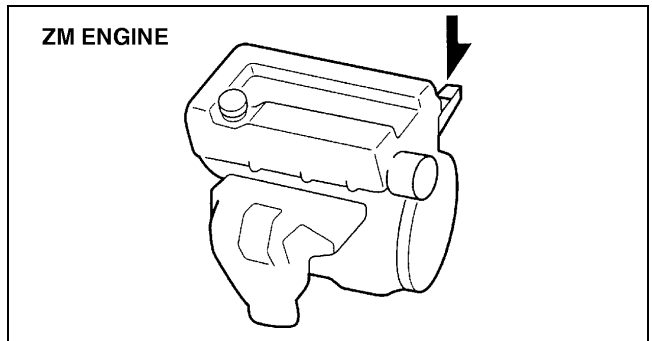

X3U000WBS

# GENERAL INFORMATION

00-00

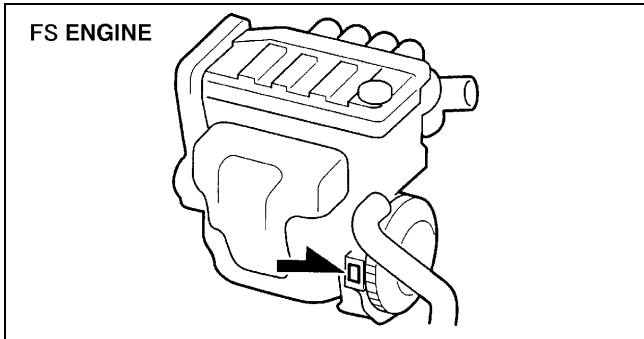

X3U000WBT

A3U000000003W01

## SAE STANDARDS

- In accordance with new regulations, SAE (Society of Automotive Engineers) standard names and abbreviations are now used in this manual. The table below lists the names and abbreviations that have been used in Mazda manuals up to now and their SAE equivalents.

SAE Standard		Remark
Abbreviation	Name	
AP	Accelerator Pedal	
ACL	Air Cleaner	
A/C	Air Conditioning	
BARO	Barometric Pressure	
B+	Battery Positive Voltage	
CMP sensor	Camshaft Position Sensor	
CAC	Charge Air Cooler	
CLS	Closed Loop System	
CTP	Closed Throttle Position	
CPP	Clutch Pedal Position	
CIS	Continuous Fuel Injection System	
CKP sensor	Crankshaft Position Sensor	
DLC	Data Link Connector	
DTM	Diagnostic Test Mode	#1
DTC	Diagnostic Trouble Code(s)	
DI	Distributor Ignition	
EI	Electronic Ignition	#2
ECT	Engine Coolant Temperature	
EM	Engine Modification	
EVAP	Evaporative Emission	
EGR	Exhaust Gas Recirculation	
FC	Fan Control	
FF	Flexible Fuel	
4GR	Fourth Gear	
GEN	Generator	
GND	Ground	
HO2S	Heated Oxygen Sensor	With heater
IAC	Idle Air control	
IAT	Intake Air Temperature	
KS	Knock Sensor	
MIL	Malfunction Indicator Lamp	

SAE Standard		Remark
Abbreviation	Name	
MAP	Manifold Absolute Pressure	
MAF sensor	Mass Air Flow Sensor	
MFI	Multiport Fuel Injection	
OBD	On-Board Diagnostic	
OL	Open Loop	
OC	Oxidation Catalytic Converter	
O2S	Oxygen Sensor	
PNP	Park/Neutral Position	
PSP	Power Steering Pressure	
PCM	Powertrain Control Module	#3
PAIR	Pulsed Secondary Air Injection	Pulsed injection
AIR	Secondary Air Injection	Injection with air pump
SAPV	Secondary Air Pulse Valve	
SFI	Sequential Multipoint Fuel Injection	
3GR	Third Gear	
TWC	Three Way Catalytic Converter	
TB	Throttle Body	
TP sensor	Throttle Position Sensor	
TCC	Torque Converter Clutch	
TCM	Transmission (Transaxle) Control Module	
TR	Transmission (Transaxle) Range	
TC	Turbocharger	
VSS	Vehicle Speed Sensor	
VR	Voltage Regulator	
VAF sensor	Volume Air Flow Sensor	
WUTWC	Warm Up Three Way Catalytic Converter	#4
WOT	Wide Open Throttle	

- #1 : Diagnostic trouble codes depend on the diagnostic test mode
- #2 : Controlled by the PCM
- #3 : Device that controls engine and powertrain
- #4 : Directly connected to exhaust manifold



# GENERAL INFORMATION

A3U000000011W01

## ABBREVIATIONS

AAS	Air adjusting screw
ABS	Antilock brake system
ACC	Accessories
ATF	Automatic transaxle fluid
ATX	Automatic transaxle
BDC	Bottom dead center
BTDC	Before top dead center
CDCV	Canister drain cut valve
CCM	Comprehensive component monitor
CM	Control module
DC	Drive cycle
DRL	Daytime running light
E/L	Electric load
ELR	Emergency locking retractor
EX	Exhaust
HI	High
HU	ABS hydraulic unit
HVAC	Heater, ventilation, and air conditioning
IG	Ignition
IN	Intake
INT	Intermittent
LF	Left front
LH	Left hand
LO	Low
LR	Left rear
M	Motor
MAX	Maximum
MTX	Manual transaxle
O/D	Overdrive
OFF	Switch off
ON	Switch on
PCV	Positive crankcase ventilation
PRC	Pressure regulator control
P/S	Power steering
RF	Right front
RH	Right hand
RR	Right rear
SST	Special service tool
SW	Switch
TAS	Throttle adjusting screw
TDC	Top dead center
TNS	Tail number side lights
TR	Transmission range
VICS	Variable inertia charging system
VTCS	Variable tumble control system
1GR	First gear
2GR	Second gear
4SD	4 door sedan
5HB	5 door hatchback

## PRE-DELIVERY INSPECTION

### Pre-Delivery Inspection Table

#### Exterior

**INSPECT** and **ADJUST**, if necessary, the following items to specification:

- Glass, exterior bright metal and paint for damage
- Wheel lug nuts
- All weatherstrips for damage or detachment
- Operation of hood release and lock
- Operation of trunk lid and fuel lid opener
- Door operation and alignment
- Headlight aiming

**INSTALL** the following parts:

- Wheel caps

#### Under hood—engine off

**INSPECT** and **ADJUST**, if necessary, the following items to specification:

- Fuel, engine coolant, and hydraulic lines, fittings, connections, and components for leaks
- Engine oil level
- Power steering fluid level
- Brake and clutch fluid level
- Windshield washer reservoir fluid level
- Radiator coolant level and specific gravity
- Tightness of water hose clamps
- Tightness of battery terminals, electrolyte level and specific gravity
- Drive belt(s) tension
- Accelerator cable and linkage for free movement **CLEAN** the spark plugs

#### Interior

**INSPECT** the operations of the following items:

- Seat controls (slide and recline) and headrests
  - Folding rear seat (if equipped)
  - Door locks, including childproof door locks (if equipped)
  - Seat belts and warning system
  - Ignition switch and steering lock
  - Air bag system using warning light
  - Cruise control system (if equipped)
  - Shift-lock system (if equipped)
  - Starter interlock
  - All lights including warning, and indicator lights
  - Sound warning system
  - Horn, wipers, and washers
  - Wiper blades performance
- Clean** wiper blades and windshield, if necessary
- Antenna
  - Audio system (if equipped)
  - Cigarette lighter and clock
  - Power windows (if equipped)
  - Heater, defroster, and air conditioner at various mode selections (if equipped)

**INSPECT** the following items:

- Presence of spare fuse
- Upholstery and interior finish

**INSPECT** and **ADJUST**, if necessary, the following items:

- Operation and fit of windows
- Pedal height and free play of clutch pedal
- Parking brake

#### Under hood—engine running at operating temperature

**INSPECT** the following items:

- Automatic transaxle fluid level
- Operation of idle-up system for electrical load, air conditioner or power steering (if equipped)
- Ignition timing
- Idle speed

## GENERAL INFORMATION

---

### On hoist

**INSPECT** the following items:

- Manual transaxle oil level
- Underside fuel, coolant and hydraulic lines, fittings, connections, and components for leaks
- Tires for cuts or bruises
- Steering linkage, suspension, exhaust system, and all underside hardware for looseness or damage

### Road test

**INSPECT** the following items:

- Brake operation
- Clutch operation
- Steering control
- Operation of gauges
- Squeaks, rattles, and unusual noises
- Engine general performance
- Emergency locking retractors and automatic locking retractors
- Cruise control system (if equipped)

### After road test

**INSPECT** for necessary owner information materials, tools, and spare tire in vehicle

The following items must be done just before delivery to your customer.

- Load test battery and charge if necessary (Load test result: Volts)
- Adjust tire pressure to specification (Specified tire pressure is indicated on the door label.)
- Clean outside of vehicle
- Install fuses for accessories
- Remove seat and cabin carpet protective covers
- Vacuum inside of vehicle

# GENERAL INFORMATION

## SCHEDULED MAINTENANCE

A3U00000013W01

### Scheduled Maintenance Table

#### Schedule 1 : (Normal driving conditions) U.S.A.

- The vehicle is mainly operated where none of the "unique driving conditions" apply.

Maintenance Item	Maintenance Interval (Number of months or kilometers(miles), whichever comes first)								
	Months	6	12	18	24	30	36	42	48
	× 1000 km	12	24	36	48	60	72	84	96
	(× 1000 Miles)	(7.5)	(15)	(22.5)	(30)	(37.5)	(45)	(52.5)	(60)
<b>ENGINE</b>									
Engine valve clearance									I
Engine timing belt	Inspect at 96,000 km (60,000 miles). Replace every 168,000 km (105,000 miles).								
Drive belts (tension)				I					I
Engine oil	R	R	R	R	R	R	R	R	R
Oil filter	R	R	R	R	R	R	R	R	R
<b>COOLING SYSTEM</b>									
Cooling system				I					I
Engine coolant	Replace at first 72,000 km (45,000 miles) or 36 months; after that, every 48,000 km (30,000 miles) or 24 months.								
<b>FUEL SYSTEM</b>									
Idle speed				I					I
Air cleaner element				R					R
Fuel lines & hoses	*1			I					I
Hoses & tubes for emission	*1								I
<b>IGNITION SYSTEM</b>									
Spark plugs				R					R
<b>CHASSIS &amp; BODY</b>									
Brake lines, hoses & connections				I					I
Disc brakes				I					I
Drum brakes				I					I
Steering operation & linkages				I					I
Front suspension ball joints				I					I
Drive shaft dust boots				I					I
Bolts & nuts on chassis & body				I					I
Exhaust system heat shields				I					I
All locks & hinges	L	L	L	L	L	L	L	L	L
<b>AIR CONDITIONER SYSTEM (if installed)</b>									
Refrigerant amount		I		I		I		I	
Compressor operation		I		I		I		I	

#### Chart symbols

- I** : Inspect and repair, clean, adjust, or replace if necessary. (Oil-permeated air cleaner elements cannot be cleaned using the air-blow method.)
- R** : Replace
- L** : Lubricate

#### Remarks

- After the described period, continue to follow the described maintenance at the recommended intervals.
  - Refer below for a description of items marked in the maintenance chart.
- \*1 : According to state and federal regulations, failure to perform maintenance on these items will not void your emissions warranties. However, Mazda recommends that all maintenance services be performed at the recommended time or mileage period to ensure long-term reliability.

00-00

## GENERAL INFORMATION

### Schedule 2 : Canada, Puerto Rico and (Unique driving conditions) U.S.A.

Unique driving conditions consist of :

- Repeated short-distance driving.
- Driving in dusty conditions.
- Driving with extended use of brakes.
- Driving in areas where salt or other corrosive materials are used.
- Driving on rough or muddy roads.
- Extended periods of idling or low-speed operation.
- Driving for long periods in cold temperatures or extremely humid climates.

Maintenance Item	Maintenance Interval (Number of months or kilometers (miles), whichever comes first)												
	Months	4	8	12	16	20	24	28	32	36	40	44	48
	× 1000 km	8	16	24	32	40	48	56	64	72	80	88	96
	(× 1000 Miles)	(5)	(10)	(15)	(20)	(25)	(30)	(35)	(40)	(45)	(50)	(55)	(60)
<b>ENGINE</b>													
Engine valve clearance													I
Engine timing belt	*2	Inspect at 96,000 km (60,000 miles). Replace every 168,000 km (105,000 miles).											
Drive belts (tension)							I						I
Engine oil	except for Puerto Rico	R	R	R	R	R	R	R	R	R	R	R	R
	for Puerto Rico	Replace every 5,000 km (3,000 miles) (or 3 months)											
Oil filter		R	R	R	R	R	R	R	R	R	R	R	R
<b>COOLING SYSTEM</b>													
Cooling system							I						I
Engine coolant		Replace at first 72,000 km (45,000 miles) or 36 months; after that, every 48,000 km (30,000 miles) or 24 months.											
Engine coolant level		I	I	I	I	I	I	I	I	I	I	I	I
<b>FUEL SYSTEM</b>													
Idle speed							I						I
Air cleaner element			I*1				R			I*1			R
Fuel lines & hoses	*1						I						I
Hoses & tubes for emission	*1												I
<b>IGNITION SYSTEM</b>													
Spark plugs							R						R
<b>ELECTRICAL SYSTEM</b>													
Function of all lights		I	I	I	I	I	I	I	I	I	I	I	I
<b>CHASSIS &amp; BODY</b>													
Brake lines, hoses & connections							I						I
Brake & clutch fluid level		I	I	I	I	I	I	I	I	I	I	I	I
Disc brakes			I				I			I			I
Drum brakes							I						I
Tire inflation pressure & tire wear		I	I	I	I	I	I	I	I	I	I	I	I
Steering operation & linkages							I						I
Power steering fluid level		I	I	I	I	I	I	I	I	I	I	I	I
Front suspension ball joints							I						I
Driveshaft dust boots							I						I
Bolts & nuts on chassis & body			I				I			I			I
Exhaust system heat shields							I						I
All locks & hinges		L	L	L	L	L	L	L	L	L	L	L	L
Washer fluid level		I	I	I	I	I	I	I	I	I	I	I	I
<b>AIR CONDITIONER SYSTEM (if installed)</b>													
Refrigerant amount				I			I			I			I
Compressor operation				I			I			I			I

## GENERAL INFORMATION

---

### Chart symbols

- I : Inspect and repair, clean, adjust, or replace if necessary. (Oil-permeated air cleaner elements cannot be cleaned using the air-blow method.)  
R : Replace  
L : Lubricate

00-00

### Remarks

- After the described period, continue to follow the described maintenance at the recommended intervals.
  - Refer below for a description of items marked \* in the maintenance chart.
- \*1 : According to state and federal regulations, failure to perform maintenance on these items will not void your emissions warranties. However, Mazda recommends that all maintenance services be performed at the recommended time or mileage period to ensure long-term reliability.
- \*2 : If vehicle is operated in cold districts **{below -18 °C (0 °F)}**, replace the timing belt at 96,000 km **(60,000 miles)**.

# ENGINE

# 01

SECTION

01-02A

ON-BOARD DIAGNOSTIC [ENGINE CONTROL SYSTEM (ZM)] . . .	01-02A	COOLING SYSTEM . . . . .	01-12
ON-BOARD DIAGNOSTIC [ENGINE CONTROL SYSTEM (FS)] . . .	01-02B	INTAKE-AIR SYSTEM [ZM] . . .	01-13A
ON-BOARD DIAGNOSTIC [CRUISE CONTROL SYSTEM] . . . . .	01-02C	INTAKE-AIR SYSTEM [FS] . . .	01-13B
SYMPTOM TROUBLESHOOTING [ENGINE CONTROL SYSTEM (ZM)] . . . . .	01-03A	FUEL SYSTEM . . . . .	01-14
SYMPTOM TROUBLESHOOTING [ENGINE CONTROL SYSTEM (FS)] . . . . .	01-03B	EXHAUST SYSTEM . . . . .	01-15
MECHANICAL [ZM] . . . . .	01-10A	EMISSION SYSTEM . . . . .	01-16
MECHANICAL [FS] . . . . .	01-10B	CHARGING SYSTEM . . . . .	01-17
LUBRICATION . . . . .	01-11	IGNITION SYSTEM . . . . .	01-18
		STARTING SYSTEM . . . . .	01-19
		CRUISE CONTROL SYSTEM . . .	01-20
		CONTROL SYSTEM [ZM] . . . .	01-40A
		CONTROL SYSTEM [FS] . . . .	01-40B
		TECHNICAL DATA . . . . .	01-50
		SERVICE TOOLS . . . . .	01-60

## 01-02A ON-BOARD DIAGNOSTIC [ENGINE CONTROL SYSTEM (ZM)]

CONTROL SYSTEM WIRING DIAGRAM [ZM] . . . . .	01-02A-3	OBD-II DRIVE MODE [ZM] . . . . .	01-02A-11
CONTROL SYSTEM DEVICE AND CONTROL RELATIONSHIP CHART [ZM] . . . . .	01-02A-5	Mode 1 (PCM adaptive memory procedure drive mode) . . . . .	01-02A-11
Engine Control System . . . . .	01-02A-5	Mode 2 (EGR system repair verification drive mode) . . . . .	01-02A-12
Monitoring System . . . . .	01-02A-6	Mode 3 (HO2S heater, HO2S, and TWC repair verification drive mode) . . . . .	01-02A-12
FOREWORD [ZM] . . . . .	01-02A-7	Mode 4 (EVAP system repair verification drive mode) . . . . .	01-02A-13
OBD-II PENDING TROUBLE CODES [ZM] . . . . .	01-02A-7	DIAGNOSTIC MONITORING TEST RESULTS [ZM] . . . . .	01-02A-14
OBD-II FREEZE FRAME DATA [ZM] . . .	01-02A-7	DTC TABLE [ZM] . . . . .	01-02A-15
OBD-II ON-BOARD SYSTEM READINESS TEST [ZM] . . . . .	01-02A-7	DTC P0031 [ZM] . . . . .	01-02A-19
OBD-II DIAGNOSTIC MONITORING TEST RESULTS [ZM] . . . . .	01-02A-7	DTC P0032 [ZM] . . . . .	01-02A-20
OBD-II READ/CLEAR DIAGNOSTIC TEST RESULTS [ZM] . . . . .	01-02A-8	DTC P0037 [ZM] . . . . .	01-02A-22
OBD-II PARAMETER IDENTIFICATION (PID) ACCESS [ZM] . . . . .	01-02A-8	DTC P0038 [ZM] . . . . .	01-02A-23
ON-BOARD DIAGNOSTIC TEST [ZM] . . .	01-02A-8	DTC P0102 [ZM] . . . . .	01-02A-25
DTCs Retrieving Procedure . . . . .	01-02A-8	DTC P0103 [ZM] . . . . .	01-02A-28
Pending Trouble Code Access Procedure . . . . .	01-02A-8	DTC P0106 [ZM] . . . . .	01-02A-29
Freeze Frame PID Data Access Procedure . . . . .	01-02A-9	DTC P0107 [ZM] . . . . .	01-02A-31
On-Board System Readiness Tests Access Procedure . . . . .	01-02A-9	DTC P0108 [ZM] . . . . .	01-02A-32
PID/DATA Monitor and Record Procedure . . . . .	01-02A-9	DTC P0111 [ZM] . . . . .	01-02A-34
Diagnostic Monitoring Test Results Access Procedure . . . . .	01-02A-10	DTC P0112 [ZM] . . . . .	01-02A-35
AFTER REPAIR PROCEDURE [ZM] . . . .	01-02A-10	DTC P0113 [ZM] . . . . .	01-02A-36
		DTC P0117 [ZM] . . . . .	01-02A-39
		DTC P0118 [ZM] . . . . .	01-02A-41
		DTC P0122 [ZM] . . . . .	01-02A-42
		DTC P0123 [ZM] . . . . .	01-02A-45
		DTC P0125 [ZM] . . . . .	01-02A-46
		DTC P0130 [ZM] . . . . .	01-02A-48
		DTC P0134 [ZM] . . . . .	01-02A-50

## ON-BOARD DIAGNOSTIC [ENGINE CONTROL SYSTEM (ZM)]

---

DTC P0138 [ZM].....	01-02A-53	DTC P0704 [ZM] .....	01-02A-102
DTC P0140 [ZM].....	01-02A-55	DTC P0705 [ZM] .....	01-02A-104
DTC P0171 [ZM].....	01-02A-57	DTC P1102 [ZM] .....	01-02A-106
DTC P0172 [ZM].....	01-02A-60	DTC P1103 [ZM] .....	01-02A-107
DTC P0300 [ZM].....	01-02A-61	DTC P1122 [ZM] .....	01-02A-108
DTC P0301, P0302, P0303, P0304 [ZM] ..	01-02A-65	DTC P1123 [ZM] .....	01-02A-110
DTC P0335 [ZM].....	01-02A-67	DTC P1170 [ZM] .....	01-02A-111
DTC P0401 [ZM].....	01-02A-69	DTC P1250 [ZM] .....	01-02A-114
DTC P0402 [ZM].....	01-02A-70	DTC P1345 [ZM] .....	01-02A-116
DTC P0421 [ZM].....	01-02A-71	DTC P1449 [ZM] .....	01-02A-118
DTC P0442 [ZM].....	01-02A-72	DTC P1450 [ZM] .....	01-02A-120
DTC P0443 [ZM].....	01-02A-75	DTC P1487 [ZM] .....	01-02A-121
DTC P0451 [ZM].....	01-02A-77	DTC P1496 [ZM] .....	01-02A-123
DTC P0452 [ZM].....	01-02A-78	DTC P1497 [ZM] .....	01-02A-125
DTC P0453 [ZM].....	01-02A-80	DTC P1498 [ZM] .....	01-02A-127
DTC P0455 [ZM].....	01-02A-83	DTC P1499 [ZM] .....	01-02A-129
DTC P0461 [ZM].....	01-02A-87	DTC P1504 [ZM] .....	01-02A-131
DTC P0462 [ZM].....	01-02A-88	DTC P1512 [ZM] .....	01-02A-134
DTC P0463 [ZM].....	01-02A-90	DTC P1562 [ZM] .....	01-02A-135
DTC P0464 [ZM].....	01-02A-91	DTC P1569 [ZM] .....	01-02A-137
DTC P0480 [ZM].....	01-02A-92	DTC P1570 [ZM] .....	01-02A-139
DTC P0500 [ZM].....	01-02A-94	DTC P1631 [ZM] .....	01-02A-141
DTC P0506 [ZM].....	01-02A-96	DTC P1632 [ZM] .....	01-02A-143
DTC P0507 [ZM].....	01-02A-97	DTC P1633 [ZM] .....	01-02A-144
DTC P0550 [ZM].....	01-02A-99	DTC P1634 [ZM] .....	01-02A-145
DTC P0703 [ZM].....	01-02A-100		

---



# ON-BOARD DIAGNOSTIC [ENGINE CONTROL SYSTEM (ZM)]

## CONTROL SYSTEM WIRING DIAGRAM [ZM]

A3U010218881W15

01-02A

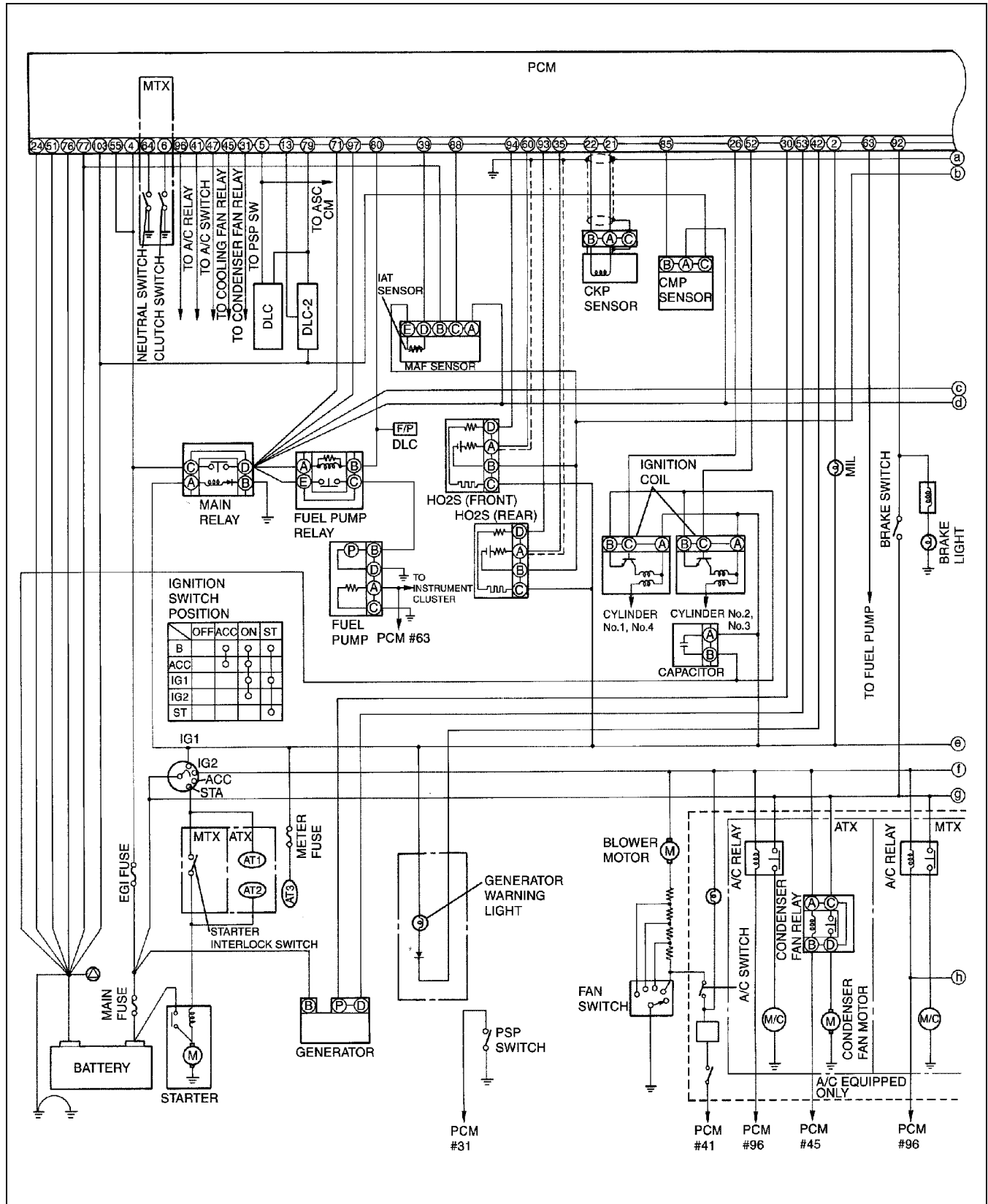

A3U0140W005



# ON-BOARD DIAGNOSTIC [ENGINE CONTROL SYSTEM (ZM)]

## CONTROL SYSTEM DEVICE AND CONTROL RELATIONSHIP CHART [ZM]

A3U010218881W16

### Engine Control System

Component	Idle air control (IAC)	Fuel injection control	Pressure regulator control (PRC)	Electronic spark advance (ESA) control	Fuel pump control	HO2S heater (front) control	HO2S heater (rear) control	Electric fan control	Purge control	EGR control	VTCS	A/C cut-out control	Generator control
<b>Input</b>													
Brake switch		x		x									
Refrigerant pressure switch, A/C switch, blower fan switch and A/C amplifier	x	x		x				x				x	
PSP switch	x	x		x								x	
DLC in engine compartment (TEN)	x	x	x	x				x					
Neutral switch (MTX)	x	x	x	x									
Clutch switch (MTX)	x	x	x	x									
TR switch (ATX)	x	x	x	x									
CKP sensor	x	x	x	x	x	x	x	x	x	x	x	x	x
CMP sensor	x	x		x									
VSS	x	x		x						x			x
MAF sensor	x	x		x		x	x		x	x			
ECT sensor	x	x	x	x		x	x	x	x	x	x	x	x
IAT sensor	x	x	x	x		x			x	x			x
TP sensor	x	x	x	x		x		x	x	x	x	x	x
EGR boost sensor	x	x							x			x	
Battery positive voltage		x		x		x			x				x
Generator	x			x									x
HO2S (front)		x							x				
HO2S (rear)													
<b>Output</b>													
IAC valve	x												
A/C relay												x	
Cooling fan relay								x					
Condenser fan relay								x					
Fuel pump relay					x								
PRC solenoid valve			x										
Purge solenoid valve									x				
VTCS solenoid valve											x		
EGR valve										x			
HO2S heater						x	x						
Ignition coils				x									
Fuel injectors		x											
Generator (field coil)													x
Generator warning light													x

01-02A

# ON-BOARD DIAGNOSTIC [ENGINE CONTROL SYSTEM (ZM)]

## Monitoring System

× : Applied

Component	Catalyst monitor	Misfire monitor	Evaporative system monitor	Fuel system monitor	Oxygen sensor monitor	Oxygen sensor heater monitor	EGR system monitor
<b>Input</b>							
Brake switch							
Refrigerant pressure switch, A/C switch, blower fan switch and A/C amplifier		×		×			×
PSP switch		×		×			×
CKP sensor	×	×	×	×	×	×	×
CMP sensor	×	×	×	×	×	×	×
VSS	×	×	×	×	×		×
MAF sensor	×	×	×	×	×	×	×
ECT sensor	×	×	×	×	×	×	×
IAT sensor	×	×	×	×	×		×
TP sensor	×	×	×	×	×		×
EGR boost sensor							×
Fuel level sensor			×				
Fuel gauge sender unit			×				
Rear HO2S	×				×	×	
Front HO2S	×			×	×	×	
<b>Output</b>							
DLC-2 in passenger compartment (Terminal KLN)	×	×	×	×	×	×	×
MIL	×	×	×	×	×	×	×
Purge solenoid valve			×	×	×		
EGR valve							×
EGR boost sensor solenoid valve							×
Canister drain cut valve			×				
Fuel injectors				×			

Y3U102WBC

# ON-BOARD DIAGNOSTIC [ENGINE CONTROL SYSTEM (ZM)]

## FOREWORD [ZM]

A3U010218881W17

- When the customer reports a vehicle malfunction, check the malfunction indicator light (MIL) and diagnostic trouble code (DTC), then diagnose the malfunction according to following flowchart.
  - If the DTC exists, diagnose the applicable DTC inspection. (See 01-02A-15 DTC TABLE [ZM].)
  - If the DTC does not exist and the MIL does not illuminate or flash, diagnose the applicable symptom troubleshooting. (See 01-03A-7 SYMPTOM DIAGNOSTIC INDEX [ZM].)

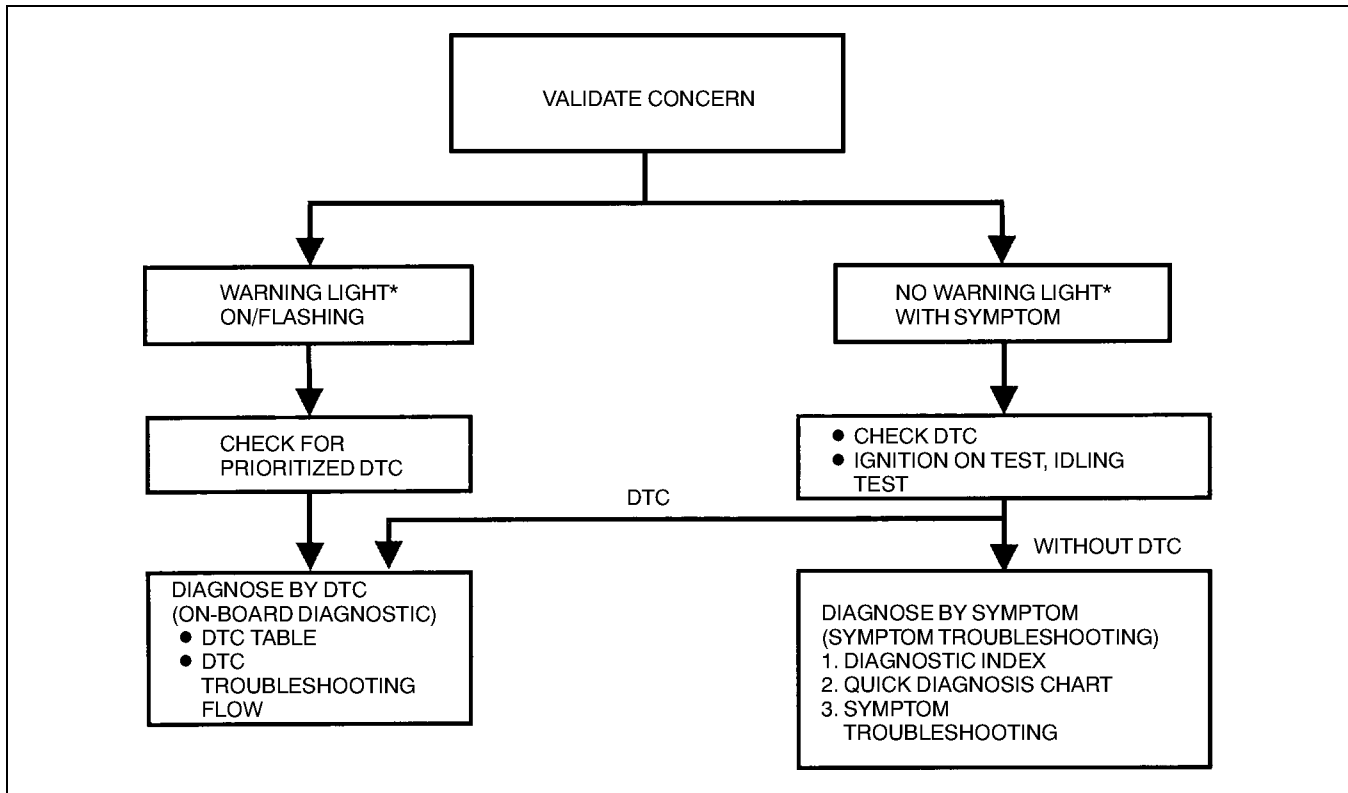

01-02A

YMU102WBX

\* : Malfunction Indicator Light (MIL), Generator Warning Light, Security Light

## OBD-II PENDING TROUBLE CODES [ZM]

A3U010218881W18

- The following functions are generic functions.
- These appear when a problem is detected in a monitored system. The MIL is illuminated when a problem is detected in two consecutive drive cycles. The code for a failed system is stored in the PCM memory in the first drive cycle. This code is called the pending code. If the problem is not found in the second drive cycle, the PCM judges that the system returned to normal or the problem was mistakenly detected, and deletes the pending code. If the problem is found in the second drive cycle too, the PCM judges that the system has failed, deletes the pending code, illuminates the MIL and store the DTC.

## OBD-II FREEZE FRAME DATA [ZM]

A3U010218881W19

- This is the technical data which indicates the engine's condition at the time of the first malfunction. This data will remain in the memory even if another emission-related DTC is stored, with the exception of the Misfire or Fuel System DTCs. Once freeze frame data for the Misfire or Fuel System DTC is stored, it will overwrite any previous data and the freeze frame will not be overwritten again.

## OBD-II ON-BOARD SYSTEM READINESS TEST [ZM]

A3U010218881W20

- This shows OBD-II systems operating status. If any monitor function is incomplete, WDS or equivalent will identify which monitor function has not been completed. Misfires, Fuel System and Comprehensive Components (CCM) are continuous monitoring-type functions. The catalyst, EGR system, evaporation system and oxygen sensor will be monitored under drive cycles. The OBD-II diagnostic system is initialized by performing the DTC cancellation procedure or disconnecting the negative battery cable.

## OBD-II DIAGNOSTIC MONITORING TEST RESULTS [ZM]

A3U010218881W21

- These results from the intermittent monitor system's technical data, which are used to determine whether the system is normal or not. They also display the system's thresholds and diagnostic results. The intermittent monitor system monitors the oxygen sensor, evaporative purge system, catalyst and the EGR system.

# ON-BOARD DIAGNOSTIC [ENGINE CONTROL SYSTEM (ZM)]

## OBD-II READ/CLEAR DIAGNOSTIC TEST RESULTS [ZM]

A3U010218881W22

- The following are generic functions.
- This retrieves all stored DTCs in the PCM and clears the DTC, Freeze Frame Data, On-Board Readiness Test Results, Diagnostic Monitoring Test Results and Pending Trouble Codes.

## OBD-II PARAMETER IDENTIFICATION (PID) ACCESS [ZM]

A3U010218881W23

- The PID mode allows access to certain data values, analog and digital inputs and outputs, calculated values and system status information. Since PID values for output devices are PCM internal data values, inspect each device to identify which output devices are malfunctioning.

## ON-BOARD DIAGNOSTIC TEST [ZM]

A3U010218881W24

### DTCs Retrieving Procedure

1. Perform the necessary vehicle preparation and visual inspection.
2. Connect WDS or equivalent to the vehicle DLC-2 16-pin connector located on the left side of the steering column.
3. Retrieve DTC using WDS or equivalent.

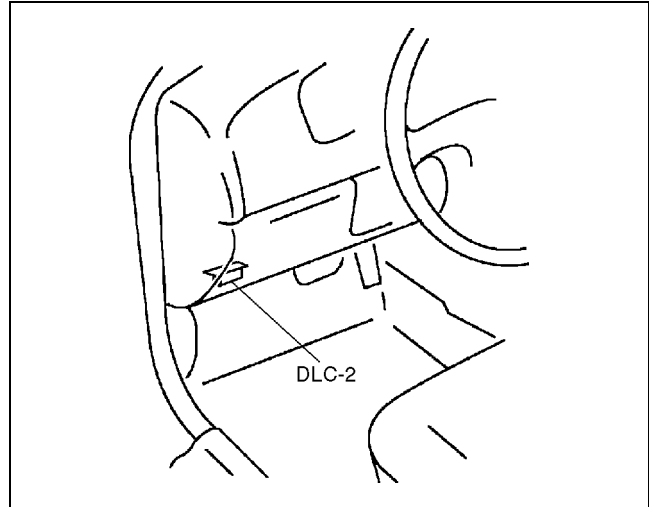

Z3U0102W001

### Pending Trouble Code Access Procedure

1. Perform the necessary vehicle preparation and visual inspection.
2. Connect WDS or equivalent to the vehicle DLC-2 16-pin connector located on the left side of the steering column.
3. Retrieve pending trouble code using WDS or equivalent.

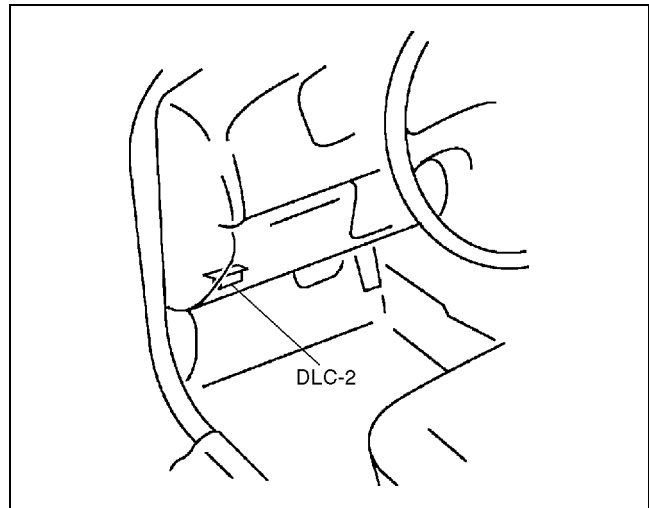

Z3U0102W001

## ON-BOARD DIAGNOSTIC [ENGINE CONTROL SYSTEM (ZM)]

### Freeze Frame PID Data Access Procedure

1. Perform the necessary vehicle preparation and visual inspection.
2. Connect WDS or equivalent to the vehicle DLC-2 16-pin connector located on the left side of the steering column.
3. Retrieve FREEZE FRAME PID DATA using WDS or equivalent.

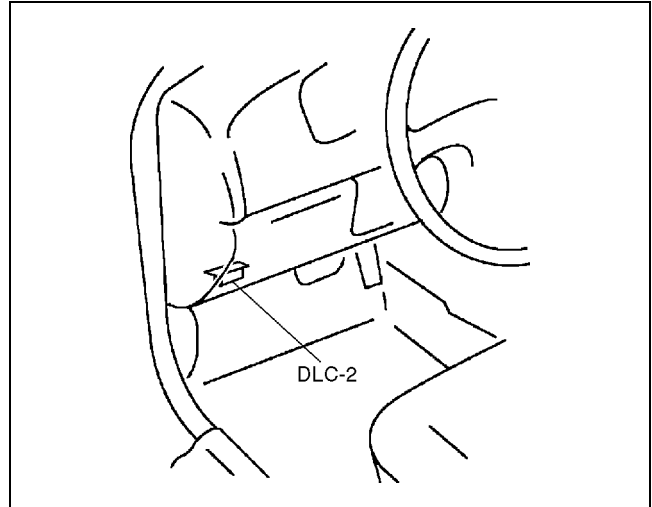

Z3U0102W001

01-02A

### On-Board System Readiness Tests Access Procedure

1. Perform the necessary vehicle preparation and visual inspection.
2. Connect WDS or equivalent to the vehicle DLC-2 16-pin connector located on the left side of the steering column.
3. Monitor the OBD-II system operating status using WDS or equivalent.

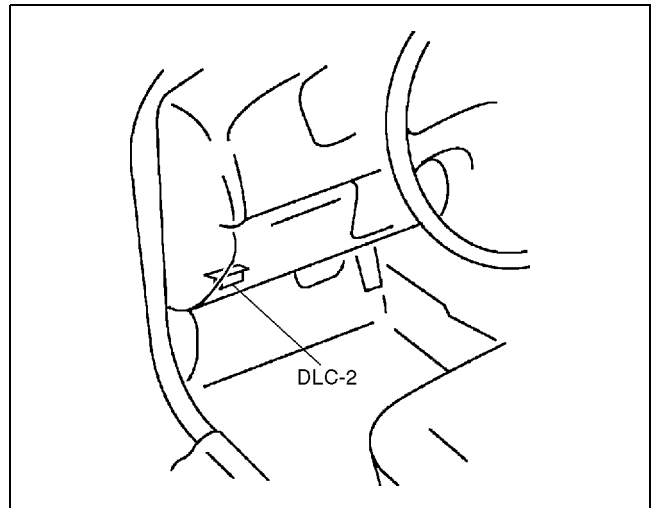

Z3U0102W001

### PID/DATA Monitor and Record Procedure

1. Perform the necessary vehicle preparation and visual inspection.
2. Connect WDS or equivalent to the vehicle DLC-2 16-pin connector located on the left side of the steering column.
3. Access and monitor DTCs using WDS or equivalent.

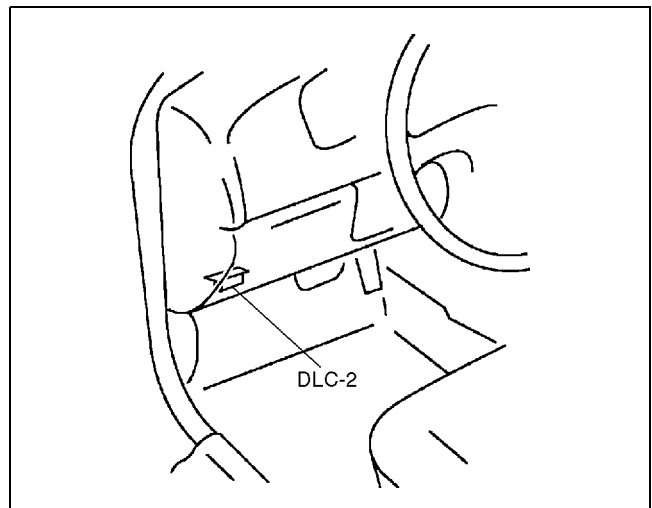

Z3U0102W001

## ON-BOARD DIAGNOSTIC [ENGINE CONTROL SYSTEM (ZM)]

### Diagnostic Monitoring Test Results Access Procedure

1. Perform the necessary vehicle preparation and visual inspection.
2. Connect WDS or equivalent to the vehicle DLC-2 16-pin connector located on the left side of the steering column.
3. Access the DIAGNOSTIC MONITORING TEST RESULTS and read the test results using WDS or equivalent.

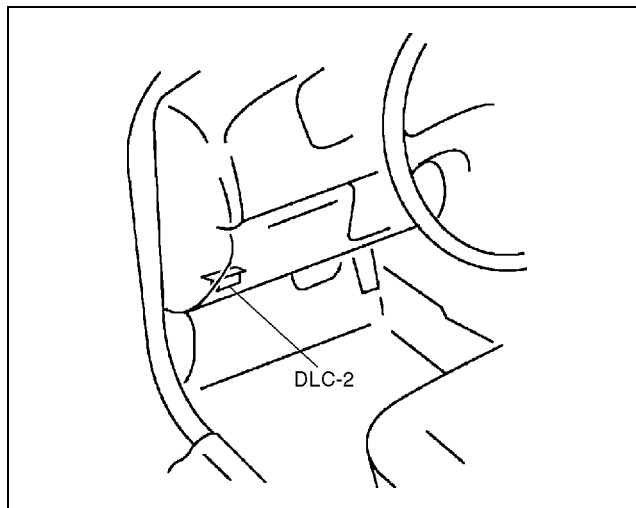

Z3U0102W001

### AFTER REPAIR PROCEDURE [ZM]

1. Connect WDS or equivalent to the vehicle DLC-2 16-pin connector located on the left side of the steering column.
2. Cycle the ignition key from OFF to ON.
3. Record DTC if retrieved.
4. Erase all diagnostic data using WDS or equivalent.

A3U010218881W25

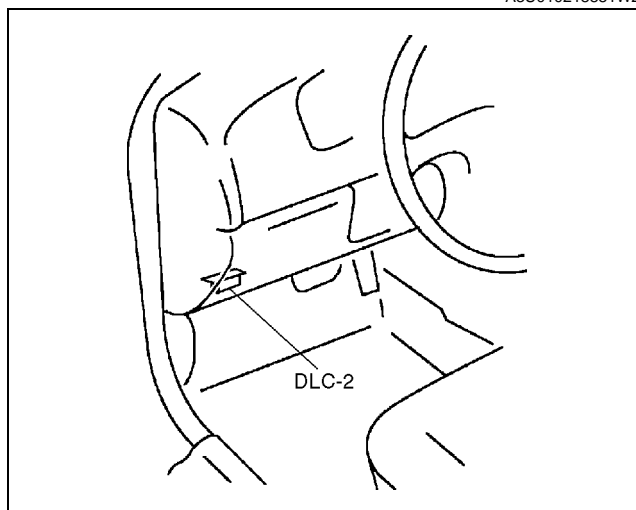

Z3U0102W001



## OBD-II DRIVE MODE [ZM]

A3U010218881W26

01-02A

- Performing the Drive Mode inspects the OBD-II system for proper operation and must be performed to ensure that no additional DTCs are present.
- During Drive Mode, the following systems are inspected:
  - EGR system
  - Oxygen sensor (HO2S)
  - Oxygen sensor heater
  - Catalytic converter (TWC)
  - Fuel, misfire and evaporative (EVAP) system

### Caution

- **While performing the Drive Mode, always operate the vehicle in a safe and lawful manner.**
- **When the WDS or equivalent is used to observe monitor system status while driving, be sure to have another technician with you, or record the data in the WDS or equivalent using the PID/DATA MONITOR AND RECORD function and inspect later.**

### Note

- Vehicle speed and engine speed detected by the PCM may differ from that indicated by the speedometer and tachometer. Use the WDS or equivalent to monitor vehicle speed.
- If the OBD-II system inspection is not completed during the Drive Mode, the following causes are considered:
  1. The OBD-II system detects the malfunction.
  2. The Drive Mode procedure is not completed correctly.
- Disconnecting the battery will reset the memory. Do not disconnect the battery during and after Drive Mode.

### Mode 1 (PCM adaptive memory procedure drive mode)

1. Start the engine and warm up completely.
2. Verify the following conditions and correct if necessary.
  - All accessory loads (A/C, headlights, blower fan, rear window defroster) are off.
  - Initial ignition timing and idle speed are within specification.
  - TEN and GND of DLC are not connected.
3. Perform no load racing at the engine speed shown in the graph, then idle the engine for **more than 20 seconds** after the cooling fan stopped. If possible, monitor RPM PID for engine speed and cooling fan status during this procedure.

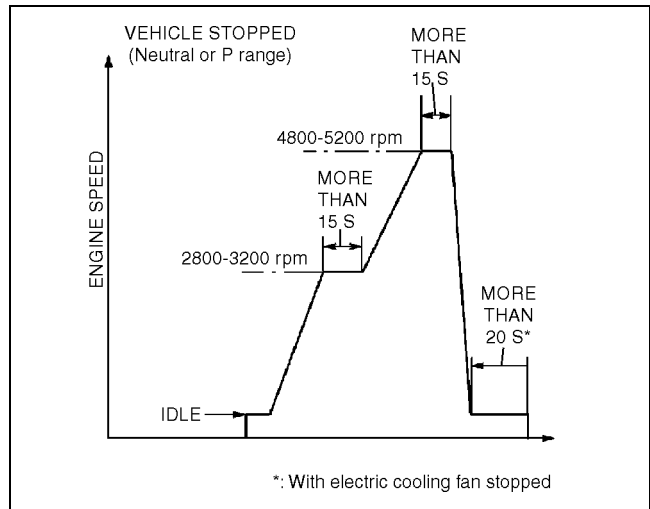

Z3U0102W002

## ON-BOARD DIAGNOSTIC [ENGINE CONTROL SYSTEM (ZM)]

### Mode 2 (EGR system repair verification drive mode)

1. Perform Mode 1 first.
2. Verify all accessory loads (A/C, headlights, blower fan, rear window defroster) are off.
3. Drive the vehicle as shown in the graph.
4. Stop vehicle and access ON BOARD SYSTEM READINESS menu of GENERIC OBD II FUNCTION to inspect the Drive Mode completion status. If completed, RFC changes from NO to YES.
5. If not completed, turn the ignition key off then go back to Step 3.
6. Access DIAGNOSTIC MONITORING TEST RESULTS menu of GENERIC OBD II FUNCTIONS to inspect the monitor results. If MEAS are not within specification, repair has not been completed.
7. Verify no DTCs are available.

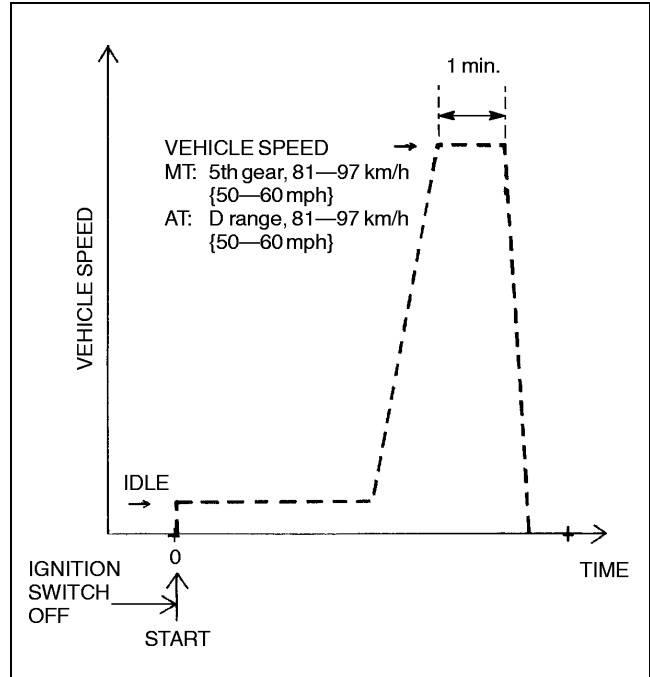

X3U101WBL

### Mode 3 (HO2S heater, HO2S, and TWC repair verification drive mode)

1. Perform Mode 1 first.
2. Verify all accessory loads (A/C, headlights, blower fan, rear window defroster) are off.
3. Drive the vehicle as shown in the graph. Driving condition before the constant speed driving is not specified.
4. Stop vehicle and access ON BOARD SYSTEM READINESS menu of GENERIC OBD II FUNCTION to inspect the Drive Mode completion status. If completed, RFC changes from NO to YES.
5. If not completed, turn the ignition key off then go back to Step 3.
6. Access DIAGNOSTIC MONITORING TEST RESULTS menu of GENERIC OBD II FUNCTIONS to inspect the monitor results. If MEAS are not within specification, repair has not been completed.
7. Verify no DTCs are available.

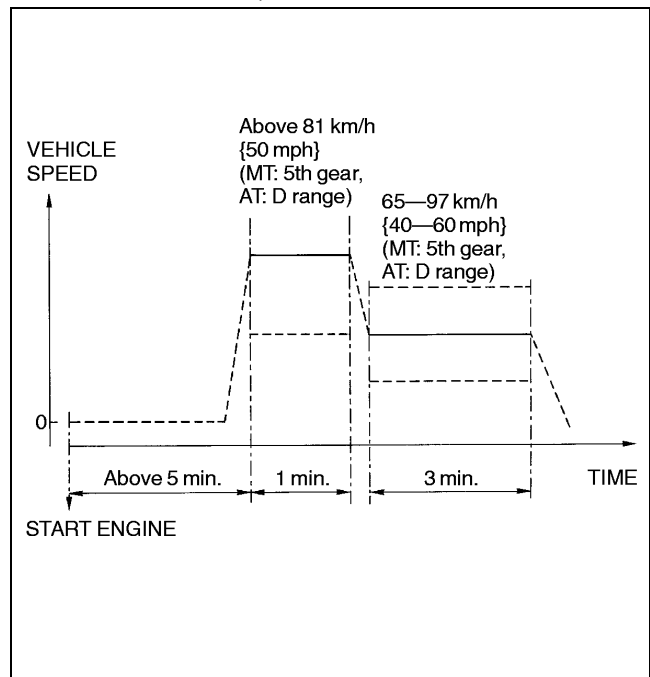

X3U101WBM

# ON-BOARD DIAGNOSTIC [ENGINE CONTROL SYSTEM (ZM)]

## Mode 4 (EVAP system repair verification drive mode)

### Note

- If Mode 4 can not be performed (you can not drive the vehicle under Mode 4 condition), perform evaporative system test procedure as an alternative. (See 01-03A-56 Evaporative System Leak Inspection Using Vacuum Pump.)
- Mode 4 can be performed regardless RFC FLAG condition.

01-02A

1. Verify that the following conditions are met. All conditions must be within specifications before engine is started to initiate the evaporative system test.

- Barometric pressure: **72.2 kPa {542 mmHg, 21.3 inHg} or higher**
- Intake air temperature: **10—60 °C {50—140 °F}**
- Fuel tank level: **0.5—2.5 V**
- Engine coolant temperature: **-10 °C—X °C {14 °F—X °F}** (X, the Engine coolant temperature upper limit, is determined according to the barometric pressure as shown the graph below.)

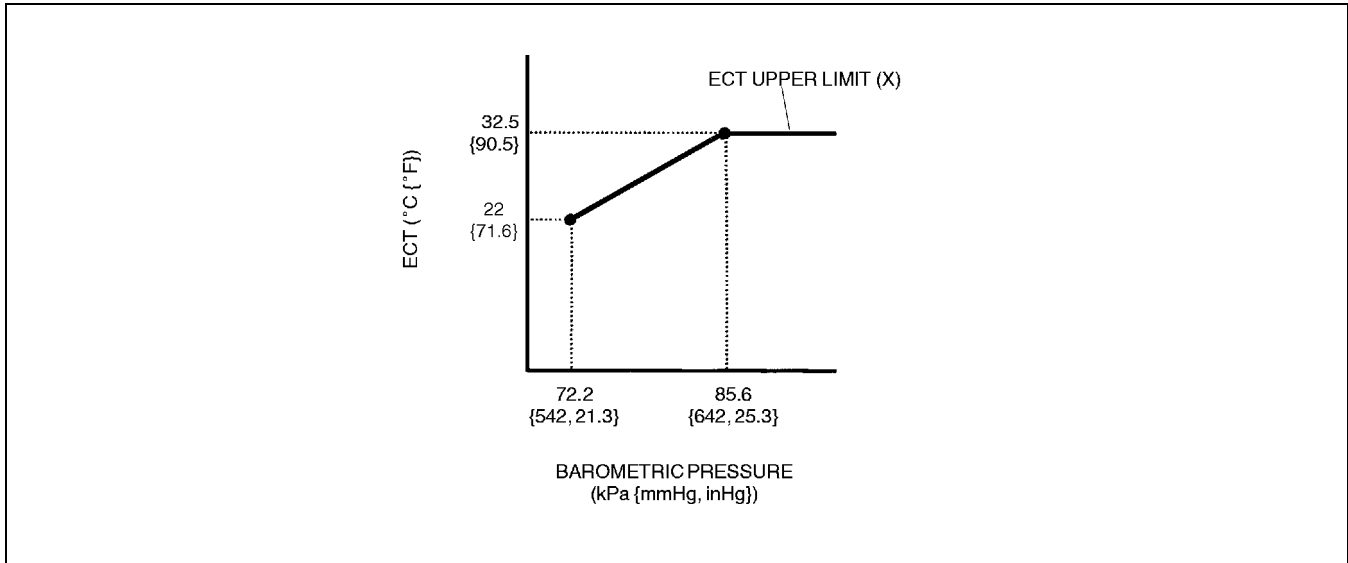

Z3U0102W003

2. Verify all accessory loads (A/C, headlights, blower fan, rear window defroster) are off.
3. Start the engine and race it at **3,500 rpm** to warm up completely.
4. Drive the vehicle as shown in the graph.

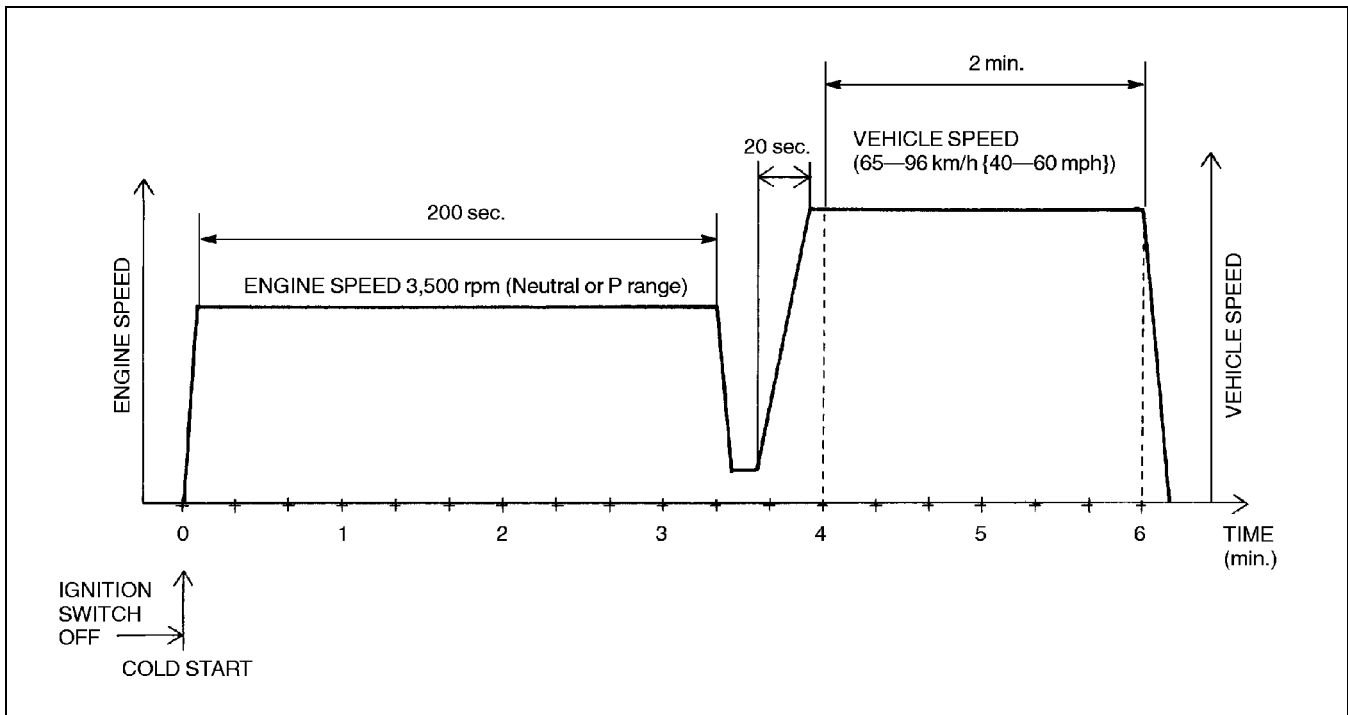

X3U101WBN

## ON-BOARD DIAGNOSTIC [ENGINE CONTROL SYSTEM (ZM)]

5. Stop vehicle and access ON BOARD SYSTEM READINESS menu of GENERIC OBD II FUNCTION to inspect the Drive Mode completion status. If completed, RFC changes from NO to YES.
6. If not completed, turn the ignition key off then go back to Step 1.
7. Access DIAGNOSTIC MONITORING TEST RESULTS menu of GENERIC OBD II FUNCTION to inspect the monitor results. If MEAS are not within specification, repair has not been completed.
8. Verify no DTCs are available.

### DIAGNOSTIC MONITORING TEST RESULTS [ZM]

A3U010218881W27

- The purpose of this test mode is to confirm the OBD-II monitor diagnostic test results. The result values are stored when a particular monitor is completed and displayed. If the monitor is not completed, initial value is displayed.

TEST ID	Description	Related system	Initial value (MEAS)
10:01:11	HO2S (Front) inversion cycles	HO2S	(0)
10:02:11	HO2S (Front) lean-to-rich response time		(0)
10:03:11	HO2S (Front) rich-to-lean response time		(0)
10:04:01	HO2S (Front) rich/lean inversion voltage		113
10:04:02	Middle/HO2S (Rear) rich/lean inversion voltage		113
10:05:01	HO2S (Front) lean threshold voltage		72
10:06:01	HO2S (Front) rich threshold voltage		113
10:11:11	Front and rear HO2S (RH) switching time ratio	TWC	(65535)
10:21:00	In-tank pressure evaporative purge system (small leak)	EVAP	(0)
10:22:00	In-tank pressure evaporative purge system (large leak)		(0)
10:41:00	EGR pressure variation	EGR	(32768)

# ON-BOARD DIAGNOSTIC [ENGINE CONTROL SYSTEM (ZM)]

## DTC TABLE [ZM]

A3U010218881W28

DTC No.	Condition	MIL	O/D off indicator light	DC	Monitor item	Memory function	Page
P0031	HO2S heater (front) circuit low	ON	—	2	O <sub>2</sub> sensor heater	×	(See 01-02A-19 DTC P0031 [ZM])
P0032	HO2S heater (front) circuit high	ON	—	2	O <sub>2</sub> sensor heater	×	(See 01-02A-20 DTC P0032 [ZM])
P0037	HO2S heater (rear) circuit low	ON	—	2	O <sub>2</sub> sensor heater	×	(See 01-02A-22 DTC P0037 [ZM])
P0038	HO2S heater (rear) circuit high	ON	—	2	O <sub>2</sub> sensor heater	×	(See 01-02A-23 DTC P0038 [ZM])
P0102	MAF circuit low input	ON	—	1	CCM	×	(See 01-02A-25 DTC P0102 [ZM])
P0103	MAF circuit high input	ON	—	1	CCM	×	(See 01-02A-28 DTC P0103 [ZM])
P0106	BARO circuit performance problem	ON	—	2	CCM	×	(See 01-02A-29 DTC P0106 [ZM])
P0107	BARO circuit low input	ON	—	1	CCM	×	(See 01-02A-31 DTC P0107 [ZM])
P0108	BARO circuit high input	ON	—	1	CCM	×	(See 01-02A-32 DTC P0108 [ZM])
P0111	IAT circuit performance problem	ON	—	2	CCM	×	(See 01-02A-34 DTC P0111 [ZM])
P0112	IAT circuit low input	ON	—	1	CCM	×	(See 01-02A-35 DTC P0112 [ZM])
P0113	IAT circuit high input	ON	—	1	CCM	×	(See 01-02A-36 DTC P0113 [ZM])
P0117	ECT circuit low input	ON	—	1	CCM	×	(See 01-02A-39 DTC P0117 [ZM])
P0118	ECT circuit high input	ON	—	1	CCM	×	(See 01-02A-41 DTC P0118 [ZM])
P0122	TP circuit low input	ON	Flashing	1	CCM	×	(See 01-02A-42 DTC P0122 [ZM])
P0123	TP circuit high input	ON	Flashing	1	CCM	×	(See 01-02A-45 DTC P0123 [ZM])
P0125	Excessive time to enter closed loop fuel control	ON	—	2	CCM	×	(See 01-02A-46 DTC P0125 [ZM])
P0130	HO2S (Front) circuit malfunction	ON	—	2	O <sub>2</sub> sensor	×	(See 01-02A-48 DTC P0130 [ZM])
P0134	HO2S (Front) circuit no activity detected	ON	—	2	CCM	×	(See 01-02A-50 DTC P0134 [ZM])
P0138	HO2S (Rear) circuit high input	ON	—	2	CCM	×	(See 01-02A-53 DTC P0138 [ZM])
P0140	HO2S (Rear) circuit no activity detected	ON	—	2	CCM	×	(See 01-02A-55 DTC P0140 [ZM])
P0171	Fuel trim system too lean	ON	—	2	Fuel	×	(See 01-02A-57 DTC P0171 [ZM])
P0172	Fuel trim system too rich	ON	—	2	Fuel	×	(See 01-02A-60 DTC P0172 [ZM])
P0300	Random misfire detected	Flashing or ON	—	1 or 2	Misfire	×	(See 01-02A-61 DTC P0300 [ZM])
P0301	Cylinder 1 misfire detected	Flashing or ON	—	1 or 2	Misfire	×	(See 01-02A-65 DTC P0301, P0302, P0303, P0304 [ZM])
P0302	Cylinder 2 misfire detected	Flashing or ON	—	1 or 2	Misfire	×	(See 01-02A-65 DTC P0301, P0302, P0303, P0304 [ZM])
P0303	Cylinder 3 misfire detected	Flashing or ON	—	1 or 2	Misfire	×	(See 01-02A-65 DTC P0301, P0302, P0303, P0304 [ZM])
P0304	Cylinder 4 misfire detected	Flashing or ON	—	1 or 2	Misfire	×	(See 01-02A-65 DTC P0301, P0302, P0303, P0304 [ZM])
P0335	CKP sensor circuit malfunction	ON	—	1	CCM	×	(See 01-02A-67 DTC P0335 [ZM])

01-02A

## ON-BOARD DIAGNOSTIC [ENGINE CONTROL SYSTEM (ZM)]

DTC No.	Condition	MIL	O/D off indicator light	DC	Monitor item	Memory function	Page
P0401	EGR flow insufficient detected	ON	—	2	EGR	×	(See 01-02A-69 DTC P0401 [ZM])
P0402	EGR flow excessive detected	ON	—	2	EGR	×	(See 01-02A-70 DTC P0402 [ZM])
P0421	Warm-up catalyst system efficiency below threshold	ON	—	2	Catalyst	×	(See 01-02A-71 DTC P0421 [ZM])
P0442	Evaporative emission system leak detected (small leak)	ON	—	2	Evaporative	×	(See 01-02A-72 DTC P0442 [ZM])
P0443	Evaporative emission control system purge solenoid valve circuit malfunction	OFF	—	—	Other	—	(See 01-02A-75 DTC P0443 [ZM])
P0451	Fuel tank pressure sensor performance problem	ON	—	2	CCM	×	(See 01-02A-77 DTC P0451 [ZM])
P0452	Fuel tank pressure sensor low input	ON	—	2	CCM	×	(See 01-02A-78 DTC P0452 [ZM])
P0453	Fuel tank pressure sensor high input	ON	—	2	CCM	×	(See 01-02A-80 DTC P0453 [ZM])
P0455	Evaporative emission control system leak detected (blockage or large leak)	ON	—	2	Evaporative	×	(See 01-02A-83 DTC P0455 [ZM])
P0461	Fuel gauge sender unit circuit range/performance	ON	—	2	CCM	×	(See 01-02A-87 DTC P0461 [ZM])
P0462	Fuel gauge sender unit circuit low input	ON	—	2	CCM	×	(See 01-02A-88 DTC P0462 [ZM])
P0463	Fuel gauge sender unit circuit high input	ON	—	2	CCM	×	(See 01-02A-90 DTC P0463 [ZM])
P0464	Fuel gauge sender unit circuit performance (slosh check)	ON	—	2	CCM	×	(See 01-02A-91 DTC P0464 [ZM])
P0480	Cooling fan relay malfunction	OFF	—	2	CCM	×	(See 01-02A-92 DTC P0480 [ZM])
P0500	VSS circuit malfunction (MTX)	ON	—	2	CCM	×	(See 01-02A-94 DTC P0500 [ZM])
	VSS circuit malfunction (ATX)						
P0506	Idle control system RPM lower than expected	ON	—	2	CCM	×	(See 01-02A-96 DTC P0506 [ZM])
P0507	Idle control system RPM higher than expected	ON	—	2	CCM	×	(See 01-02A-97 DTC P0507 [ZM])
P0550	PSP switch circuit malfunction	ON	—	2	CCM	×	(See 01-02A-99 DTC P0550 [ZM])
P0703	Brake switch input malfunction	ON	—	2	CCM	×	(See 01-02A-100 DTC P0703 [ZM])
P0704	Clutch switch input circuit malfunction (MTX)	ON	—	2	CCM	×	(See 01-02A-102 DTC P0704 [ZM])
P0705	Neutral switch input circuit malfunction (MTX)	ON	—	2	CCM	×	(See 01-02A-104 DTC P0705 [ZM])
P0705	TR switch circuit malfunction (ATX)	(See 05-02-6 AUTOMATIC TRANSAXLE ON-BOARD DIAGNOSTIC FUNCTION)					
P0706	TR switch circuit malfunction (Open circuit) (ATX)	(See 05-02-6 AUTOMATIC TRANSAXLE ON-BOARD DIAGNOSTIC FUNCTION)					
P0710	Transaxle temperature sensor circuit malfunction (Open or short) (ATX)	(See 05-02-6 AUTOMATIC TRANSAXLE ON-BOARD DIAGNOSTIC FUNCTION)					

## ON-BOARD DIAGNOSTIC [ENGINE CONTROL SYSTEM (ZM)]

DTC No.	Condition	MIL	O/D off indicator light	DC	Monitor item	Memory function	Page
P0711	Transaxle temperature sensor circuit range/performance (Stuck) (ATX)						(See 05-02-6 AUTOMATIC TRANSAXLE ON-BOARD DIAGNOSTIC FUNCTION)
P0715	Input/turbine speed sensor circuit malfunction (ATX)						(See 05-02-6 AUTOMATIC TRANSAXLE ON-BOARD DIAGNOSTIC FUNCTION)
P0731	Gear 1 incorrect (ATX)						(See 05-02-6 AUTOMATIC TRANSAXLE ON-BOARD DIAGNOSTIC FUNCTION)
P0732	Gear 2 incorrect (ATX)						(See 05-02-6 AUTOMATIC TRANSAXLE ON-BOARD DIAGNOSTIC FUNCTION)
P0733	Gear 3 incorrect (ATX)						(See 05-02-6 AUTOMATIC TRANSAXLE ON-BOARD DIAGNOSTIC FUNCTION)
P0734	Gear 4 incorrect (ATX)						(See 05-02-6 AUTOMATIC TRANSAXLE ON-BOARD DIAGNOSTIC FUNCTION)
P0741	TCC (stuck off) (ATX)						(See 05-02-6 AUTOMATIC TRANSAXLE ON-BOARD DIAGNOSTIC FUNCTION)
P0742	TCC (stuck on) (ATX)						(See 05-02-6 AUTOMATIC TRANSAXLE ON-BOARD DIAGNOSTIC FUNCTION)
P0745	Pressure control solenoid valve malfunction (ATX)						(See 05-02-6 AUTOMATIC TRANSAXLE ON-BOARD DIAGNOSTIC FUNCTION)
P0751	Shift solenoid A malfunction (stuck off) (ATX)						(See 05-02-6 AUTOMATIC TRANSAXLE ON-BOARD DIAGNOSTIC FUNCTION)
P0752	Shift solenoid A malfunction (stuck on) (ATX)						(See 05-02-6 AUTOMATIC TRANSAXLE ON-BOARD DIAGNOSTIC FUNCTION)
P0753	Shift solenoid A malfunction (electrical) (ATX)						(See 05-02-6 AUTOMATIC TRANSAXLE ON-BOARD DIAGNOSTIC FUNCTION)
P0756	Shift solenoid B malfunction (stuck off) (ATX)						(See 05-02-6 AUTOMATIC TRANSAXLE ON-BOARD DIAGNOSTIC FUNCTION)
P0757	Shift solenoid B malfunction (stuck on) (ATX)						(See 05-02-6 AUTOMATIC TRANSAXLE ON-BOARD DIAGNOSTIC FUNCTION)
P0758	Shift solenoid B malfunction (electrical) (ATX)						(See 05-02-6 AUTOMATIC TRANSAXLE ON-BOARD DIAGNOSTIC FUNCTION)
P0761	Shift solenoid C malfunction (stuck off) (ATX)						(See 05-02-6 AUTOMATIC TRANSAXLE ON-BOARD DIAGNOSTIC FUNCTION)
P0762	Shift solenoid C malfunction (stuck on) (ATX)						(See 05-02-6 AUTOMATIC TRANSAXLE ON-BOARD DIAGNOSTIC FUNCTION)
P0763	Shift solenoid C malfunction (electrical) (ATX)						(See 05-02-6 AUTOMATIC TRANSAXLE ON-BOARD DIAGNOSTIC FUNCTION)
P0766	Shift solenoid D malfunction (stuck off) (ATX)						(See 05-02-6 AUTOMATIC TRANSAXLE ON-BOARD DIAGNOSTIC FUNCTION)
P0767	Shift solenoid D malfunction (stuck on) (ATX)						(See 05-02-6 AUTOMATIC TRANSAXLE ON-BOARD DIAGNOSTIC FUNCTION)
P0768	Shift solenoid D malfunction (electrical) (ATX)						(See 05-02-6 AUTOMATIC TRANSAXLE ON-BOARD DIAGNOSTIC FUNCTION)
P0771	Shift solenoid E malfunction (stuck off) (ATX)						(See 05-02-6 AUTOMATIC TRANSAXLE ON-BOARD DIAGNOSTIC FUNCTION)
P0772	Shift solenoid E malfunction (stuck on) (ATX)						(See 05-02-6 AUTOMATIC TRANSAXLE ON-BOARD DIAGNOSTIC FUNCTION)
P0773	Shift solenoid E malfunction (electrical) (ATX)						(See 05-02-6 AUTOMATIC TRANSAXLE ON-BOARD DIAGNOSTIC FUNCTION)

01-02A

## ON-BOARD DIAGNOSTIC [ENGINE CONTROL SYSTEM (ZM)]

DTC No.	Condition	MIL	O/D off indicator light	DC	Monitor item	Memory function	Page
P1102	MAF sensor inconsistent with TP sensor (Lower than expected)	ON	—	2	CCM	×	(See 01-02A-106 DTC P1102 [ZM])
P1103	Mass air flow inconsistent with engine speed (Greater than expected)	ON	—	2	CCM	×	(See 01-02A-107 DTC P1103 [ZM])
P1122	Throttle position stuck closed (lower than expected)	ON	—	2	CCM	×	(See 01-02A-108 DTC P1122 [ZM])
P1123	Throttle position stuck open (higher than expected)	ON	—	2	CCM	×	(See 01-02A-110 DTC P1123 [ZM])
P1170	HO2S (front) no inversion	ON	—	2	CCM	×	(See 01-02A-111 DTC P1170 [ZM])
P1250	PRC solenoid valve circuit malfunction	OFF	—	2	CCM	×	(See 01-02A-114 DTC P1250 [ZM])
P1345	CMP sensor circuit malfunction	ON	—	1	CCM	×	(See 01-02A-116 DTC P1345 [ZM])
P1449	CDCV circuit malfunction	OFF	—	—	Other	—	(See 01-02A-118 DTC P1449 [ZM])
P1450	Evaporative emission control system malfunction (excessive vacuum)	ON	—	2	CCM	×	(See 01-02A-120 DTC P1450 [ZM])
P1487	EGR boost sensor solenoid valve circuit malfunction	OFF	—	—	Other	—	(See 01-02A-121 DTC P1487 [ZM])
P1496	EGR valve stepping motor coil 1 open or short	OFF	—	—	Other	—	(See 01-02A-123 DTC P1496 [ZM])
P1497	EGR valve stepping motor coil 2 open or short	OFF	—	—	Other	—	(See 01-02A-125 DTC P1497 [ZM])
P1498	EGR valve stepping motor coil 3 open or short	OFF	—	—	Other	—	(See 01-02A-127 DTC P1498 [ZM])
P1499	EGR valve stepping motor coil 4 open or short	OFF	—	—	Other	—	(See 01-02A-129 DTC P1499 [ZM])
P1504	IAC valve circuit malfunction	ON	—	1	CCM	×	(See 01-02A-131 DTC P1504 [ZM])
P1512	VTCS shutter valve close stuck	ON	—	2	CCM	×	(See 01-02A-134 DTC P1512 [ZM])
P1562	PCM +BB voltage low	ON	—	1	CCM	×	(See 01-02A-135 DTC P1562 [ZM])
P1569	VTCS solenoid valve circuit low input	ON	—	2	CCM	×	(See 01-02A-137 DTC P1569 [ZM])
P1570	VTCS solenoid valve circuit high input	ON	—	2	CCM	×	(See 01-02A-139 DTC P1570 [ZM])
P1631	Generator output voltage signal no electricity	OFF	—	—	Other	×	(See 01-02A-141 DTC P1631 [ZM])
P1632	Battery voltage monitor signal circuit malfunction	OFF	—	—	Other	×	(See 01-02A-143 DTC P1632 [ZM])
P1633	Battery overcharge	OFF	—	—	Other	×	(See 01-02A-144 DTC P1633 [ZM])
P1634	Generator terminal B circuit open	OFF	—	—	Other	×	(See 01-02A-145 DTC P1634 [ZM])



# ON-BOARD DIAGNOSTIC [ENGINE CONTROL SYSTEM (ZM)]

DTC P0031 [ZM]

A3U010201084W29

01-02A

<b>DTC P0031</b>	<b>HO2S heater (front) circuit low</b>
<b>DETECTION CONDITION</b>	<ul style="list-style-type: none"> <li>PCM monitors HO2S heater (front) control signal at PCM terminal 94. If PCM turns the HO2S heater (front) off but voltage at terminal 94 still remains low, PCM determines that HO2S heater (front) circuit has malfunction.</li> </ul> <p><b>Note</b></p> <ul style="list-style-type: none"> <li>HO2S heater (front) is controlled by a duty signal.</li> </ul> <p><b>Diagnostic support note</b></p> <ul style="list-style-type: none"> <li>This is an intermittent monitor (O<sub>2</sub> sensor heater).</li> <li>MIL illuminates if PCM detects the above malfunction condition in two consecutive drive cycles.</li> <li>PENDING CODE is available if PCM detects the above malfunction condition during first drive cycle.</li> <li>FREEZE FRAME DATA is available.</li> <li>DTC is stored in PCM memory.</li> </ul>
	<p><b>POSSIBLE CAUSE</b></p> <ul style="list-style-type: none"> <li>HO2S (front) malfunction</li> <li>Open circuit between ignition switch terminal C and HO2S (front) terminal C</li> <li>Open circuit between HO2S (front) terminal D and PCM terminal 94</li> <li>Short to ground circuit between HO2S (front) terminal D and PCM terminal 94</li> <li>Poor connection at HO2S (front) or PCM connector</li> <li>PCM malfunction</li> </ul>

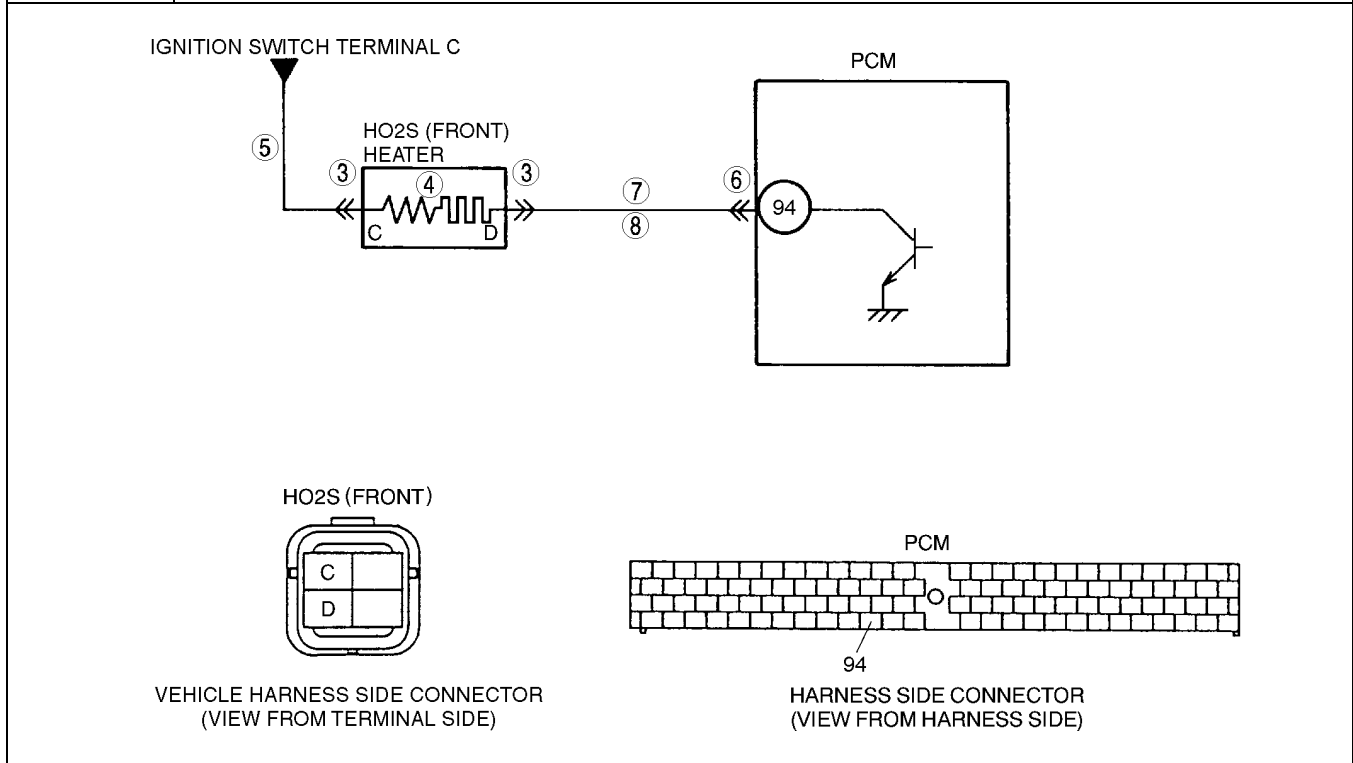

**Diagnostic procedure**

STEP	INSPECTION		ACTION
1	<b>VERIFY FREEZE FRAME DATA HAS BEEN RECORDED</b> <ul style="list-style-type: none"> <li>Has FREEZE FRAME DATA been recorded?</li> </ul>	Yes	Go to next step.
		No	Record FREEZE FRAME DATA on repair order, then go to next step.
2	<b>VERIFY RELATED REPAIR INFORMATION AVAILABILITY</b> <ul style="list-style-type: none"> <li>Check for related Service Bulletins availability.</li> <li>Is any related repair information available?</li> </ul>	Yes	Perform repair or diagnosis according to available repair information. <ul style="list-style-type: none"> <li>If vehicle is not repaired, go to next step.</li> </ul>
		No	Go to next step.
3	<b>INSPECT HO2S (FRONT) CONNECTOR FOR POOR CONNECTION</b> <ul style="list-style-type: none"> <li>Turn ignition key to OFF.</li> <li>Disconnect HO2S (front) connector.</li> <li>Check for poor connection (damaged/pulled-out pins, corrosion, etc.).</li> <li>Is there malfunction?</li> </ul>	Yes	Repair or replace terminal, then go to Step 9.
		No	Go to next step.

## ON-BOARD DIAGNOSTIC [ENGINE CONTROL SYSTEM (ZM)]

STEP	INSPECTION	ACTION	
4	<b>INSPECT HO2S HEATER (FRONT)</b> <ul style="list-style-type: none"> <li>• Measure resistance between HO2S (front) terminals C and D (part-side).</li> <li>• Is resistance <b>approx. 5.6 ohms</b>?</li> </ul>	Yes	Go to next step.
		No	Replace the HO2S (front), then go to Step 9.
5	<b>INSPECT POWER CIRCUIT OF HO2S HEATER (FRONT) FOR OPEN CIRCUIT</b> <ul style="list-style-type: none"> <li>• Turn ignition key to ON (Engine OFF).</li> <li>• Measure voltage between HO2S (front) terminal C (vehicle harness-side) and body GND.</li> <li>• Is voltage <b>B+</b>?</li> </ul>	Yes	Go to next step.
		No	Repair or replace harness for open circuit, then go to Step 9.
6	<b>INSPECT PCM CONNECTOR FOR POOR CONNECTION</b> <ul style="list-style-type: none"> <li>• Turn ignition key to OFF.</li> <li>• Disconnect PCM connector.</li> <li>• Check for poor connection at terminal 94 (damaged/pulled-out pins, corrosion, etc.).</li> <li>• Is there malfunction?</li> </ul>	Yes	Repair terminal, then go to Step 9.
		No	Go to next step.
7	<b>INSPECT CONTROL CIRCUIT OF HO2S HEATER (FRONT) FOR SHORT TO GROUND</b> <ul style="list-style-type: none"> <li>• Check for continuity between HO2S (front) terminal D (vehicle harness-side) and body GND.</li> <li>• Is there continuity?</li> </ul>	Yes	Repair or replace harness for short to ground, then go to Step 9.
		No	Go to next step.
8	<b>INSPECT CONTROL CIRCUIT OF HO2S HEATER (FRONT) FOR OPEN CIRCUIT</b> <ul style="list-style-type: none"> <li>• Connect breakout box with PCM connector disconnected.</li> <li>• Check for continuity between HO2S (front) terminal D (vehicle harness-side) and breakout box terminal 94.</li> <li>• Is there continuity?</li> </ul>	Yes	Go to next step.
		No	Repair or replace harness for open circuit, then go to Step 9.
9	<b>VERIFY TROUBLESHOOTING OF DTC P0031 COMPLETED</b> <ul style="list-style-type: none"> <li>• Make sure to reconnect all disconnected connectors.</li> <li>• Clear DTC from PCM memory using WDS or equivalent.</li> <li>• Start engine and warm it up completely.</li> <li>• Is same PENDING CODE of DTC present?</li> </ul>	Yes	Replace PCM, then go to next step.
		No	Go to next step.
10	<b>VERIFY AFTER REPAIR PROCEDURE</b> <ul style="list-style-type: none"> <li>• Perform "After Repair Procedure". (See 01-02A-10 AFTER REPAIR PROCEDURE [ZM].)</li> <li>• Is there any DTC present?</li> </ul>	Yes	Go to applicable DTC inspection. (See 01-02A-15 DTC TABLE [ZM].)
		No	Troubleshooting completed.

### DTC P0032 [ZM]

A3U010201084W30

DTC P0032	HO2S heater (front) circuit high
<b>DETECTION CONDITION</b>	<ul style="list-style-type: none"> <li>• PCM monitors HO2S heater (front) control signal at PCM terminal 94. If PCM turns HO2S heater (front) on but voltage at terminal 94 still remains high, PCM determines that HO2S heater (front) circuit has malfunction.</li> </ul> <p style="margin-left: 20px;"><b>Note</b></p> <ul style="list-style-type: none"> <li>• HO2S heater (front) is controlled by a duty signal.</li> </ul> <p><b>Diagnostic support note</b></p> <ul style="list-style-type: none"> <li>• This is an intermittent monitor (O<sub>2</sub> sensor heater).</li> <li>• MIL illuminates if PCM detects the above malfunction condition in two consecutive drive cycles.</li> <li>• PENDING CODE is available if PCM detects the above malfunction condition during first drive cycle.</li> <li>• FREEZE FRAME DATA is available.</li> <li>• DTC is stored in PCM memory.</li> </ul>
<b>POSSIBLE CAUSE</b>	<ul style="list-style-type: none"> <li>• Short to power circuit between HO2S (front) terminal D and PCM terminal 94</li> <li>• Shorted HO2S (front) or PCM terminal</li> <li>• PCM malfunction</li> </ul>

# ON-BOARD DIAGNOSTIC [ENGINE CONTROL SYSTEM (ZM)]

01-02A

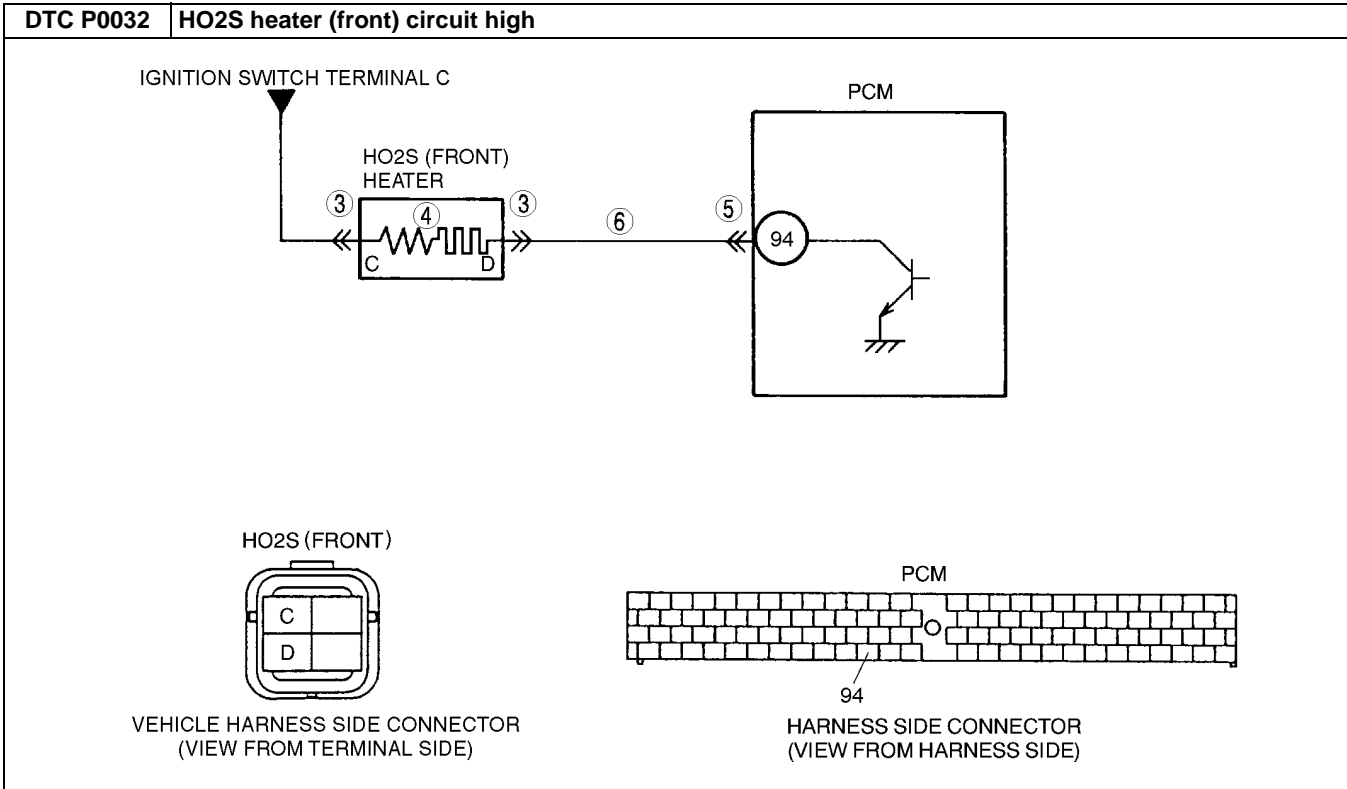

### Diagnostic procedure

STEP	INSPECTION		ACTION
1	<b>VERIFY FREEZE FRAME DATA HAS BEEN RECORDED</b> • Has FREEZE FRAME DATA been recorded?	Yes	Go to next step.
		No	Record FREEZE FRAME DATA on repair order, then go to next step.
2	<b>VERIFY RELATED REPAIR INFORMATION AVAILABILITY</b> • Check for related Service Bulletins availability. • Is any related repair information available?	Yes	Perform repair or diagnosis according to available repair information. • If vehicle is not repaired, go to next step.
		No	Go to next step.
3	<b>INSPECT HO2S (FRONT) TERMINALS</b> • Turn ignition key to OFF. • Disconnect HO2S (front) connector. • Check for bent terminals. • Is there malfunction?	Yes	Repair or replace terminal, then go to Step 7.
		No	Go to next step.
4	<b>INSPECT HO2S HEATER (FRONT)</b> • Measure resistance between HO2S (front) terminals C and D (part-side). • Is resistance <b>approx. 5.6 ohms</b> ?	Yes	Go to next step.
		No	Replace the HO2S (front), then go to Step 7.
5	<b>INSPECT PCM TERMINAL</b> • Disconnect PCM connector. • Check for bent terminal at terminal 94. • Is there malfunction?	Yes	Repair terminal, then go to Step 7.
		No	Go to next step.
6	<b>INSPECT HO2S (FRONT) HEATER CONTROL CIRCUIT FOR SHORT TO POWER CIRCUIT</b> • Turn ignition key to ON (Engine OFF). • Measure voltage between HO2S (front) terminal D (vehicle harness-side) and body ground. • Is voltage <b>B+</b> ?	Yes	Repair or replace harness for short to power circuit, then go to next step.
		No	Go to next step.
7	<b>VERIFY TROUBLESHOOTING OF DTC P0032 COMPLETED</b> • Make sure to reconnect all disconnected connectors. • Clear DTC from PCM memory using WDS or equivalent. • Start engine and warm it up completely. • Is PENDING CODE of same DTC present?	Yes	Replace PCM, then go to next step.
		No	Go to next step.

# ON-BOARD DIAGNOSTIC [ENGINE CONTROL SYSTEM (ZM)]

STEP	INSPECTION	ACTION	
8	<b>VERIFY AFTER REPAIR PROCEDURE</b> <ul style="list-style-type: none"> <li>Perform "After Repair Procedure". (See 01-02A-10 AFTER REPAIR PROCEDURE [ZM].)</li> <li>Is there any DTC present?</li> </ul>	Yes	Go to applicable DTC inspection. (See 01-02A-15 DTC TABLE [ZM].)
		No	Troubleshooting completed.

## DTC P0037 [ZM]

A3U010201084W31

DTC P0037	HO2S heater (rear) circuit low
<b>DETECTION CONDITION</b>	<ul style="list-style-type: none"> <li>PCM monitors HO2S heater (rear) control signal at PCM terminal 93. If PCM turns HO2S heater (rear) off but voltage at terminal 93 still remains low, PCM determines that HO2S heater (rear) circuit has malfunction.</li> </ul> <p><b>Diagnostic support note</b></p> <ul style="list-style-type: none"> <li>This is an intermittent monitor (O<sub>2</sub> sensor heater).</li> <li>MIL illuminates if PCM detects the above malfunction condition in two consecutive drive cycles.</li> <li>PENDING CODE is available if PCM detects the above malfunction condition during first drive cycle.</li> <li>FREEZE FRAME DATA is available.</li> <li>DTC is stored in PCM memory.</li> </ul>
<b>POSSIBLE CAUSE</b>	<ul style="list-style-type: none"> <li>HO2S (rear) malfunction</li> <li>Open circuit between ignition switch terminal C and HO2S (rear) terminal C</li> <li>Open circuit between HO2S (rear) terminal D and PCM terminal 93</li> <li>Short to ground circuit between HO2S (rear) terminal D and PCM terminal 93</li> <li>Poor connection at HO2S (rear) or PCM connector</li> <li>PCM malfunction</li> </ul>
<p>The diagram illustrates the electrical circuit for the HO2S (rear) heater. It starts with the ignition switch terminal C, which is connected to terminal C of the HO2S (rear) heater. Terminal D of the heater is connected to terminal 93 of the PCM. The PCM terminal 93 is connected to ground. The diagram also shows the vehicle harness side connector (view from terminal side) and the harness side connector (view from harness side).</p>	

## Diagnostic procedure

STEP	INSPECTION	ACTION	
1	<b>VERIFY FREEZE FRAME DATA HAS BEEN RECORDED</b> <ul style="list-style-type: none"> <li>Has FREEZE FRAME DATA been recorded?</li> </ul>	Yes	Go to next step.
		No	Record FREEZE FRAME DATA on repair order, then go to next step.
2	<b>VERIFY RELATED REPAIR INFORMATION AVAILABILITY</b> <ul style="list-style-type: none"> <li>Check for related Service Bulletins availability.</li> <li>Is any related repair information available?</li> </ul>	Yes	Perform repair or diagnosis according to available repair information. <ul style="list-style-type: none"> <li>If vehicle is not repaired, go to next step.</li> </ul>
		No	Go to next step.

## ON-BOARD DIAGNOSTIC [ENGINE CONTROL SYSTEM (ZM)]

STEP	INSPECTION	ACTION
3	<b>INSPECT HO2S (REAR) CONNECTOR FOR POOR CONNECTION</b> <ul style="list-style-type: none"> <li>Turn ignition key to OFF.</li> <li>Disconnect HO2S (rear) connector.</li> <li>Check for poor connection (damaged/pulled-out pins, corrosion, etc.).</li> <li>Is there malfunction?</li> </ul>	Yes Repair or replace terminal, then go to Step 9.
		No Go to next step.
4	<b>INSPECT HO2S HEATER (REAR)</b> <ul style="list-style-type: none"> <li>Measure resistance between HO2S (rear) terminals C and D (part-side).</li> <li>Is resistance <b>approx. 15.7 ohms</b>?</li> </ul>	Yes Go to next step.
		No Replace the HO2S (rear), then go to Step 9.
5	<b>INSPECT HO2S HEATER (REAR) POWER CIRCUIT FOR OPEN CIRCUIT</b> <ul style="list-style-type: none"> <li>Turn ignition key to ON (Engine OFF).</li> <li>Measure voltage between HO2S (rear) terminal C (vehicle harness-side) and body ground.</li> <li>Is voltage <b>B+</b>?</li> </ul>	Yes Go to next step.
		No Repair or replace harness for open circuit, then go to Step 9.
6	<b>INSPECT PCM CONNECTOR FOR POOR CONNECTION</b> <ul style="list-style-type: none"> <li>Turn ignition key to OFF.</li> <li>Disconnect PCM connector.</li> <li>Check for poor connection at terminal 93 (damaged/pulled-out pins, corrosion, etc.).</li> <li>Is there malfunction?</li> </ul>	Yes Repair terminal, then go to Step 9.
		No Go to next step.
7	<b>INSPECT HO2S HEATER (REAR) CONTROL CIRCUIT FOR SHORT TO GROUND</b> <ul style="list-style-type: none"> <li>Check for continuity between HO2S (rear) terminal D (vehicle harness-side) and body ground.</li> <li>Is there continuity?</li> </ul>	Yes Repair or replace harness for short to ground, then go to Step 9.
		No Go to next step.
8	<b>INSPECT HO2S HEATER (REAR) CONTROL CIRCUIT FOR OPEN CIRCUIT</b> <ul style="list-style-type: none"> <li>Connect breakout box with PCM connector disconnected.</li> <li>Check for continuity between HO2S (rear) terminal D (vehicle harness-side) and breakout box terminal 93.</li> <li>Is there continuity?</li> </ul>	Yes Go to next step.
		No Repair or replace harness for open circuit, then go to Step 9.
9	<b>VERIFY TROUBLESHOOTING OF DTC P0037 COMPLETED</b> <ul style="list-style-type: none"> <li>Make sure to reconnect all disconnected connectors.</li> <li>Clear DTC from PCM memory using WDS or equivalent.</li> <li>Start engine and warm it up completely.</li> <li>Is PENDING CODE of same DTC present?</li> </ul>	Yes Replace PCM, then go to next step.
		No Go to next step.
10	<b>VERIFY AFTER REPAIR PROCEDURE</b> <ul style="list-style-type: none"> <li>Perform "After Repair Procedure". (See 01-02A-10 AFTER REPAIR PROCEDURE [ZM].)</li> <li>Is there any DTC present?</li> </ul>	Yes Go to applicable DTC inspection. (See 01-02A-15 DTC TABLE [ZM].)
		No Troubleshooting completed.

01-02A

### DTC P0038 [ZM]

A3U010201084W32

DTC P0038	HO2S heater (rear) circuit high
<b>DETECTION CONDITION</b>	<ul style="list-style-type: none"> <li>PCM monitors HO2S heater (rear) control signal at PCM terminal 93. If PCM turns HO2S heater (rear) on but voltage at terminal 93 still remains high, PCM determines that HO2S heater (rear) circuit has malfunction.</li> </ul> <p><b>Diagnostic support note</b></p> <ul style="list-style-type: none"> <li>This is an intermittent monitor (O<sub>2</sub> sensor heater).</li> <li>MIL illuminates if PCM detects the above malfunction condition in two consecutive drive cycles.</li> <li>PENDING CODE is available if PCM detects the above malfunction condition during first drive cycle.</li> <li>FREEZE FRAME DATA is available.</li> <li>DTC is stored in PCM memory.</li> </ul>

01-02A-23

# ON-BOARD DIAGNOSTIC [ENGINE CONTROL SYSTEM (ZM)]

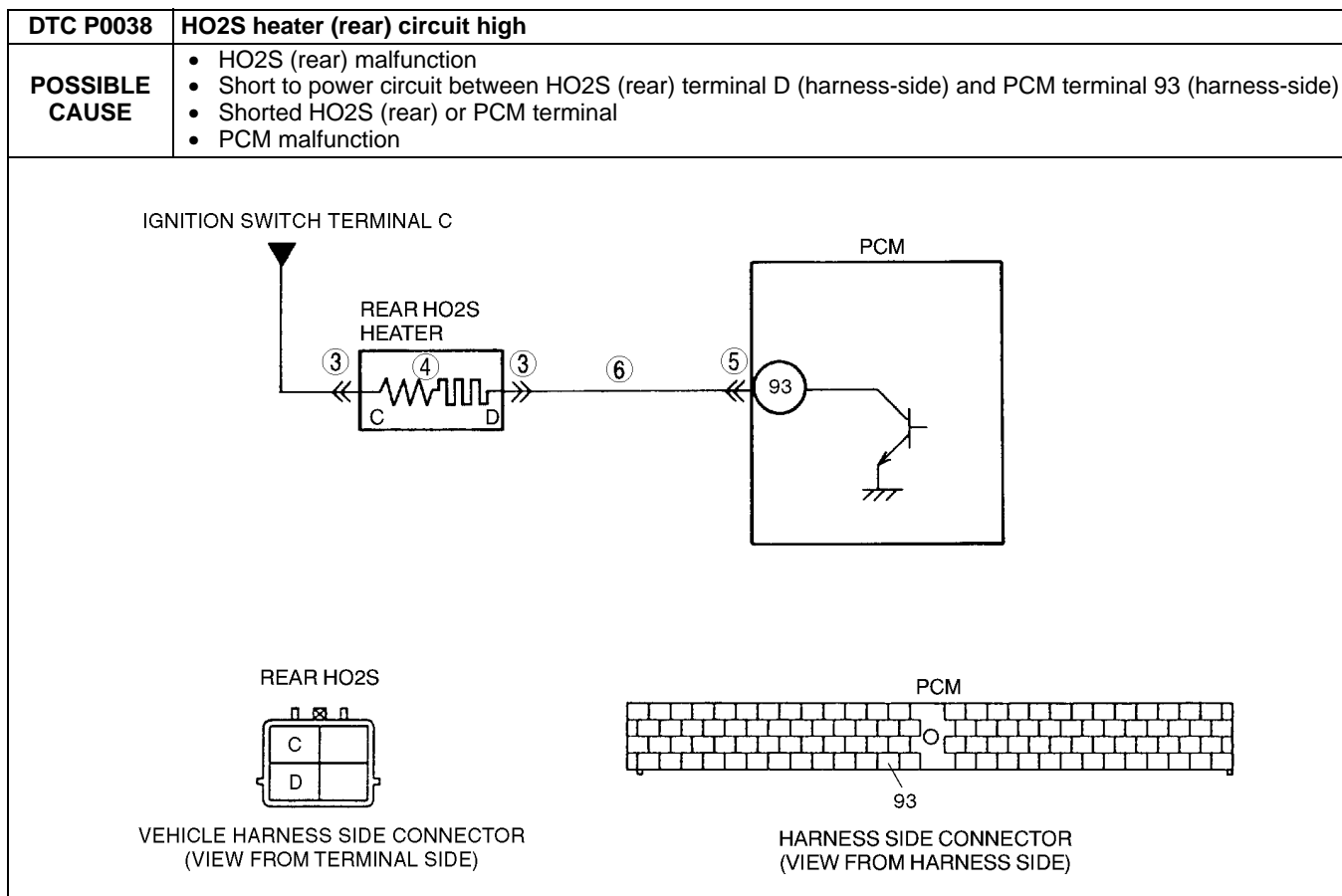

### Diagnostic procedure

STEP	INSPECTION		ACTION
1	<b>VERIFY FREEZE FRAME DATA HAS BEEN RECORDED</b> <ul style="list-style-type: none"> <li>Has FREEZE FRAME DATA been recorded?</li> </ul>	Yes	Go to next step.
		No	Record FREEZE FRAME DATA on repair order, then go to next step.
2	<b>VERIFY RELATED REPAIR INFORMATION AVAILABILITY</b> <ul style="list-style-type: none"> <li>Check for related Service Bulletins availability.</li> <li>Is any related repair information available?</li> </ul>	Yes	Perform repair or diagnosis according to available repair information. <ul style="list-style-type: none"> <li>If vehicle is not repaired, go to next step.</li> </ul>
		No	Go to next step.
3	<b>INSPECT HO2S (REAR) TERMINAL</b> <ul style="list-style-type: none"> <li>Turn ignition key to OFF.</li> <li>Disconnect HO2S (rear) connector.</li> <li>Check for bent terminals.</li> <li>Is there malfunction?</li> </ul>	Yes	Repair or replace terminal, then go to Step 7.
		No	Go to next step.
4	<b>INSPECT HO2S HEATER (REAR)</b> <ul style="list-style-type: none"> <li>Measure resistance between HO2S (rear) terminals C and D (part-side).</li> <li>Is resistance <b>approx. 15.7 ohms</b></li> </ul>	Yes	Go to next step.
		No	Replace the HO2S (rear), then go to Step 7.
5	<b>INSPECT PCM TERMINAL</b> <ul style="list-style-type: none"> <li>Disconnect PCM connector.</li> <li>Check for bent terminal at terminal 93.</li> <li>Is there malfunction?</li> </ul>	Yes	Repair terminal, then go to Step 7.
		No	Go to next step.
6	<b>INSPECT HO2S (REAR) HEATER CONTROL CIRCUIT FOR SHORT TO POWER</b> <ul style="list-style-type: none"> <li>Turn ignition key to ON (Engine OFF).</li> <li>Measure voltage between HO2S (rear) terminal D (vehicle harness-side) and body ground.</li> <li>Is voltage <b>B+</b>?</li> </ul>	Yes	Repair or replace harness for short to power circuit, then go to next step.
		No	Go to next step.

# ON-BOARD DIAGNOSTIC [ENGINE CONTROL SYSTEM (ZM)]

STEP	INSPECTION		ACTION
7	<b>VERIFY TROUBLESHOOTING OF DTC P0038 COMPLETED</b> <ul style="list-style-type: none"> <li>Make sure to reconnect all disconnected connectors.</li> <li>Clear DTC from PCM memory using WDS or equivalent.</li> <li>Start engine and warm it up completely.</li> <li>Is PENDING CODE of same DTC present?</li> </ul>	Yes	Replace PCM, then go to next step.
		No	Go to next step.
8	<b>VERIFY AFTER REPAIR PROCEDURE</b> <ul style="list-style-type: none"> <li>Perform "After Repair Procedure". (See 01-02A-10 AFTER REPAIR PROCEDURE [ZM].)</li> <li>Is there any DTC present?</li> </ul>	Yes	Go to applicable DTC inspection. (See 01-02A-15 DTC TABLE [ZM].)
		No	Troubleshooting completed.

01-02A

## DTC P0102 [ZM]

A3U010201084W33

DTC P0102	MAF circuit low input
<b>DETECTION CONDITION</b>	<ul style="list-style-type: none"> <li>PCM monitors input voltage from MAF sensor. If input voltage at PCM terminal 88 is <b>below 0.21 V</b>, PCM determines that MAF circuit has a malfunction.</li> </ul> <p><b>Diagnostic support note</b></p> <ul style="list-style-type: none"> <li>This is a continuous monitor (CCM).</li> <li>MIL illuminates if PCM detects the above malfunction condition during first drive cycle. Therefore, PENDING CODE is not available.</li> <li>FREEZE FRAME DATA is available.</li> <li>DTC is stored in PCM memory.</li> </ul>
<b>POSSIBLE CAUSE</b>	<ul style="list-style-type: none"> <li>MAF sensor malfunction</li> <li>Connector or terminal malfunction</li> <li>Short to ground in wiring between MAF sensor terminal C and PCM terminal 88</li> <li>Open circuit in wiring between MAF sensor terminal C and PCM terminal 88</li> <li>PCM malfunction</li> <li>Open circuit in wiring between MAF sensor terminal B and PCM terminal 77</li> <li>Open circuit in wiring between main relay and MAF sensor terminal A</li> </ul>

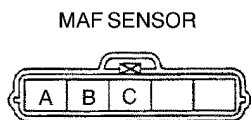
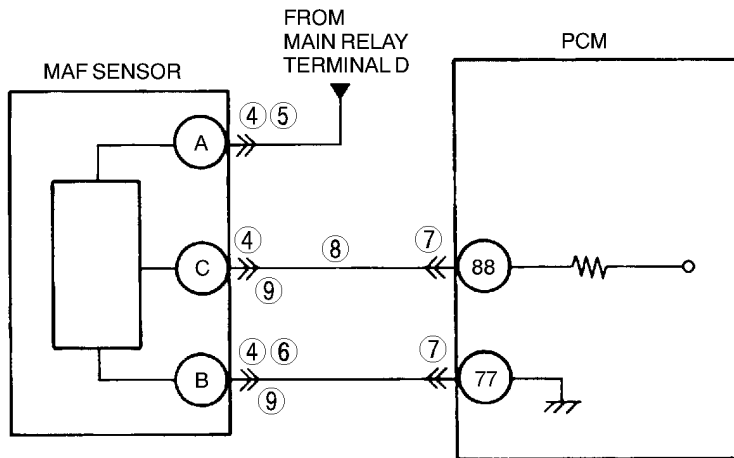

HARNESS SIDE CONNECTOR  
(VIEW FROM TERMINAL SIDE)

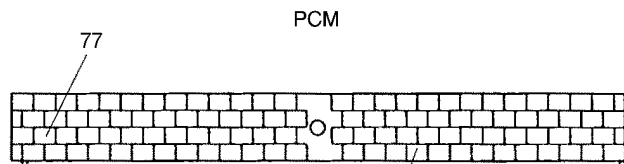

HARNESS SIDE CONNECTOR  
(VIEW FROM HARNESS SIDE)

## ON-BOARD DIAGNOSTIC [ENGINE CONTROL SYSTEM (ZM)]

### Diagnostic procedure

STEP	INSPECTION	ACTION	
1	<b>VERIFY FREEZE FRAME DATA HAS BEEN RECORDED</b> <ul style="list-style-type: none"> <li>• Has FREEZE FRAME DATA been recorded?</li> </ul>	Yes	Go to next step.
		No	Record FREEZE FRAME DATA on repair order, then go to next step.
2	<b>VERIFY RELATED REPAIR INFORMATION AVAILABILITY</b> <ul style="list-style-type: none"> <li>• Check for related Service Bulletins availability.</li> <li>• Is any related repair information available?</li> </ul>	Yes	Perform repair or diagnosis according to available repair information. <ul style="list-style-type: none"> <li>• If vehicle is not repaired, go to next step.</li> </ul>
		No	Go to next step.
3	<b>VERIFY CURRENT INPUT SIGNAL STATUS-IS CONCERN INTERMITTENT OR CONSTANT</b> <ul style="list-style-type: none"> <li>• Connect WDS or equivalent to DLC-2.</li> <li>• Start engine.</li> <li>• Access MAF PID.</li> <li>• Is MAF PID <b>above 0 g/s</b> and <b>168.7 g/s</b> or <b>below?</b></li> </ul>	Yes	Intermittent concern exists. Go to INTERMITTENT CONCERN TROUBLESHOOTING procedure. (See 01-03A-4 INTERMITTENT CONCERN TROUBLESHOOTING [ZM].)
		No	Go to next step.
4	<b>INSPECT MAF SENSOR CONNECTOR FOR POOR CONNECTION</b> <ul style="list-style-type: none"> <li>• Turn ignition key to OFF.</li> <li>• Disconnect MAF sensor connector.</li> <li>• Check for poor connection (damaged/pulled-out terminals, corrosion, etc.).</li> <li>• Is there malfunction?</li> </ul>	Yes	Repair or replace terminals, then go to Step 10.
		No	Go to next step.
5	<b>CHECK POWER SUPPLY CIRCUIT FOR OPEN CIRCUIT</b> <ul style="list-style-type: none"> <li>• Turn ignition key to ON (Engine OFF).</li> <li>• Check voltage at MAF sensor terminal A (harness-side).</li> <li>• Is voltage <b>B+</b>?</li> </ul>	Yes	Go to next step.
		No	Inspect for open circuit in wiring harness between MAF sensor terminal A (harness-side) and main relay. Repair or replace harness, then go to Step 10.
6	<b>INSPECT MAF SENSOR GROUND CIRCUIT FOR OPEN CIRCUIT</b> <ul style="list-style-type: none"> <li>• Check for continuity between MAF sensor terminal B (harness-side) and body ground.</li> <li>• Is there continuity?</li> </ul>	Yes	Go to next step.
		No	Check for open circuit between PCM terminal 36 (harness-side) and MAF sensor terminal B (harness-side). Repair or replace suspected harness, then go to Step 10.
7	<b>INSPECT PCM CONNECTOR FOR POOR CONNECTION</b> <ul style="list-style-type: none"> <li>• Turn ignition key to OFF.</li> <li>• Disconnect PCM connector.</li> <li>• Check for poor connection (damaged/pulled-out terminals, corrosion, etc.).</li> <li>• Is there malfunction?</li> </ul>	Yes	Repair terminal, then go to Step 10.
		No	Go to next step.
8	<b>INSPECT MAF SENSOR SIGNAL CIRCUIT FOR OPEN CIRCUIT</b> <ul style="list-style-type: none"> <li>• Connect breakout box with PCM disconnected.</li> <li>• Check for continuity between MAF sensor terminal C (harness-side) and breakout box terminal 88 (harness-side).</li> <li>• Is there continuity?</li> </ul>	Yes	Go to next step.
		No	Repair or replace suspected harness, then go to Step 10.
9	<b>INSPECT MAF SENSOR SIGNAL CIRCUIT FOR SHORTS</b> <ul style="list-style-type: none"> <li>• Check continuity between following circuits:                             <ul style="list-style-type: none"> <li>— MAF sensor terminal C (harness-side) and body ground</li> <li>— MAF sensor connector terminal B (harness-side) and C (harness-side)</li> </ul> </li> <li>• Is there continuity?</li> </ul>	Yes	Repair or replace suspected harness, then go to next step.
		No	Go to next step.



## ON-BOARD DIAGNOSTIC [ENGINE CONTROL SYSTEM (ZM)]

STEP	INSPECTION	ACTION	
10	<b>VERIFY TROUBLESHOOTING OF DTC P0102 COMPLETED</b> <ul style="list-style-type: none"> <li>• Make sure to reconnect all disconnected connectors.</li> <li>• Start engine.</li> <li>• Clear DTC from memory using WDS or equivalent.</li> <li>• Access MAF PID.</li> </ul> <p><b>Note</b></p> <ul style="list-style-type: none"> <li>• MAF PID should indicate <b>above 0 g/s</b> and <b>168.7 g/s or below</b>.</li> </ul> <ul style="list-style-type: none"> <li>• Is same DTC present?</li> </ul>	Yes	Replace PCM, then go to next step.
		No	Go to next step.
11	<b>VERIFY AFTER REPAIR PROCEDURE</b> <ul style="list-style-type: none"> <li>• Perform "After Repair Procedure". (See 01-02A-10 AFTER REPAIR PROCEDURE [ZM].)</li> <li>• Is there any DTC present?</li> </ul>	Yes	Go to applicable DTC inspection. (See 01-02A-15 DTC TABLE [ZM].)
		No	Troubleshooting completed.

01-02A

# ON-BOARD DIAGNOSTIC [ENGINE CONTROL SYSTEM (ZM)]

**DTC P0103 [ZM]**

A3U010201084W34

<b>DTC P0103</b>	<b>MAF circuit high input</b>
<b>DETECTION CONDITION</b>	<ul style="list-style-type: none"> <li>PCM monitors input voltage from MAF sensor after ignition key is turned on. If input voltage at PCM terminal 88 is <b>above 4.90 V</b>, PCM determines that MAF circuit has a malfunction.</li> </ul> <p><b>Diagnostic support note</b></p> <ul style="list-style-type: none"> <li>This is a continuous monitor (CCM).</li> <li>MIL illuminates if PCM detects the above malfunction condition during first drive cycle. Therefore, PENDING CODE is not available.</li> <li>FREEZE FRAME DATA is available.</li> <li>DTC is stored in PCM memory.</li> </ul>
<b>POSSIBLE CAUSE</b>	<ul style="list-style-type: none"> <li>MAF sensor malfunction</li> <li>Connector or terminal malfunction</li> <li>Short to power circuit in wiring between MAF sensor terminal C and PCM terminal 88</li> </ul>

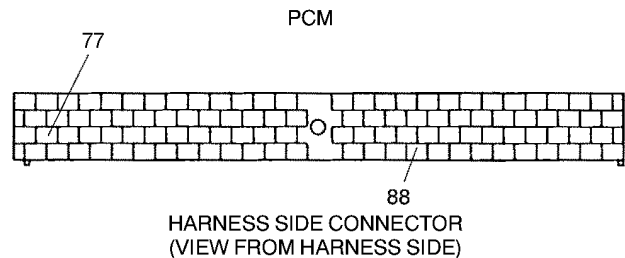
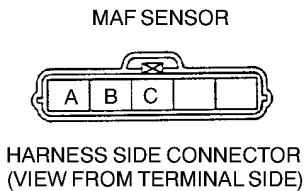
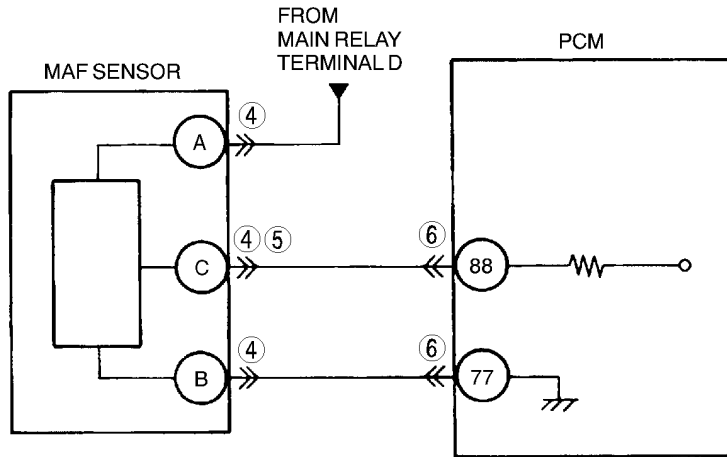

**Diagnostic procedure**

STEP	INSPECTION		ACTION
1	<b>VERIFY FREEZE FRAME DATA HAS BEEN RECORDED</b> <ul style="list-style-type: none"> <li>Has FREEZE FRAME DATA been recorded?</li> </ul>	Yes	Go to next step.
		No	Record FREEZE FRAME DATA on repair order, then go to next step.
2	<b>VERIFY RELATED REPAIR INFORMATION AVAILABILITY</b> <ul style="list-style-type: none"> <li>Check for related Service Bulletins availability.</li> <li>Is any related repair information available?</li> </ul>	Yes	Perform repair or diagnosis according to available repair information. <ul style="list-style-type: none"> <li>If vehicle is not repaired, then go to next step.</li> </ul>
		No	Go to next step.
3	<b>VERIFY CURRENT INPUT SIGNAL STATUS-IS CONCERN INTERMITTENT OR CONSTANT</b> <ul style="list-style-type: none"> <li>Connect WDS or equivalent to DLC-2.</li> <li>Start engine.</li> <li>Access MAF PID.</li> <li>Is MAF PID <b>above 0 g/s</b> and <b>168.7 g/s</b> or <b>below</b>?</li> </ul>	Yes	Intermittent concern exists. Go to INTERMITTENT CONCERN TROUBLESHOOTING procedure. (See 01-03A-4 INTERMITTENT CONCERN TROUBLESHOOTING [ZM].)
		No	Go to next step.

## ON-BOARD DIAGNOSTIC [ENGINE CONTROL SYSTEM (ZM)]

STEP	INSPECTION	ACTION	
4	<b>INSPECT MAF SENSOR CONNECTOR FOR POOR CONNECTION</b> <ul style="list-style-type: none"> <li>• Turn ignition key to OFF.</li> <li>• Disconnect the MAF sensor connector.</li> <li>• Check for bent terminal.</li> <li>• Is there malfunction?</li> </ul>	Yes	Repair or replace terminals, then go to Step 7.
		No	Go to next step.
5	<b>INSPECT MAF SIGNAL CIRCUIT FOR SHORT TO POWER CIRCUIT</b> <ul style="list-style-type: none"> <li>• Turn ignition key to ON (Engine OFF).</li> <li>• Measure voltage between MAF sensor terminal C (harness-side) and body ground.</li> <li>• Is voltage <b>0 V</b>?</li> </ul>	Yes	Go to next step.
		No	Repair or replace suspected harness, then go to Step 7.
6	<b>INSPECT PCM CONNECTOR FOR POOR CONNECTION</b> <ul style="list-style-type: none"> <li>• Turn ignition key to OFF.</li> <li>• Disconnect PCM connector.</li> <li>• Check for bent terminals.</li> <li>• Is there malfunction?</li> </ul>	Yes	Repair terminal, then go to Step 7.
		No	Go to next step.
7	<b>VERIFY TROUBLESHOOTING OF DTC P0103 COMPLETED</b> <ul style="list-style-type: none"> <li>• Make sure to reconnect all disconnected connectors.</li> <li>• Start engine.</li> <li>• Clear DTC from memory using WDS or equivalent.</li> <li>• Access MAF PID.</li> </ul> <p><b>Note</b></p> <ul style="list-style-type: none"> <li>• MAF PID should indicate <b>above 0 g/s</b> and <b>168.7 g/s or below</b>.</li> </ul> <ul style="list-style-type: none"> <li>• Is same DTC present?</li> </ul>	Yes	Replace PCM, then go to next step.
		No	Go to next step.
8	<b>VERIFY AFTER REPAIR PROCEDURE</b> <ul style="list-style-type: none"> <li>• Perform "After Repair Procedure". (See 01-02A-10 AFTER REPAIR PROCEDURE [ZM].)</li> <li>• Is there any DTC present?</li> </ul>	Yes	Go to applicable DTC inspection. (See 01-02A-15 DTC TABLE [ZM].)
		No	Troubleshooting completed.

01-02A

### DTC P0106 [ZM]

A3U010201084W35

DTC P0106	BARO circuit performance problem
<b>DETECTION CONDITION</b>	<ul style="list-style-type: none"> <li>• PCM monitors differences between intake manifold vacuum and atmospheric pressure at idle, which EGR boost sensor detects by switching EGR boost sensor solenoid. If difference is <b>below 6.43 kPa {48.2 mmHg, 1.90 inHg}</b>, PCM determines that there is EGR boost sensor performance problem.</li> </ul> <p><b>Diagnostic support note</b></p> <ul style="list-style-type: none"> <li>• This is a continuous monitor (CCM).</li> <li>• MIL illuminates if PCM detects the above malfunction condition in two consecutive drive cycles.</li> <li>• PENDING CODE is available if PCM detects the above malfunction condition during first drive cycle.</li> <li>• FREEZE FRAME DATA is available.</li> <li>• DTC is stored in PCM memory.</li> </ul>
<b>POSSIBLE CAUSE</b>	<ul style="list-style-type: none"> <li>• EGR boost sensor malfunction or substandard performance</li> <li>• EGR boost sensor solenoid malfunction</li> <li>• Loose, damaged, misconnected, clogged or frozen moisture in vacuum hose from EGR boost sensor solenoid to EGR boost sensor</li> <li>• PCM malfunction</li> <li>• Loose, damaged, misconnected, clogged or frozen moisture in vacuum hose from EGR boost sensor solenoid to EGR valve</li> </ul>

## ON-BOARD DIAGNOSTIC [ENGINE CONTROL SYSTEM (ZM)]

### Diagnostic procedure

STEP	INSPECTION	ACTION	
1	<b>VERIFY FREEZE FRAME DATA HAS BEEN RECORDED</b> <ul style="list-style-type: none"> <li>• Has FREEZE FRAME DATA been recorded?</li> </ul>	Yes	Go to next step.
		No	Record FREEZE FRAME DATA on repair order, then go to next step.
2	<b>VERIFY RELATED REPAIR INFORMATION AVAILABILITY</b> <ul style="list-style-type: none"> <li>• Check for related Service Bulletins availability.</li> <li>• Is any related repair information available?</li> </ul>	Yes	Perform repair or diagnosis according to available repair information. <ul style="list-style-type: none"> <li>• If vehicle is not repaired, go to next step.</li> </ul>
		No	Go to next step.
3	<b>VERIFY STORED DTC</b> <ul style="list-style-type: none"> <li>• Turn ignition key to OFF then start engine.</li> <li>• Has DTC P1487 been stored?</li> </ul>	Yes	Inspect and repair DTC P1487.
		No	Go to next step.
4	<b>IDENTIFY TRIGGER DTC FOR FREEZE FRAME DATA</b> <ul style="list-style-type: none"> <li>• Is DTC P0106 on FREEZE FRAME DATA?</li> </ul>	Yes	Go to next step.
		No	Go to troubleshooting procedures for DTC on FREEZE FRAME DATA.
5	<b>INSPECT CONNECTION OF EGR BOOST SENSING RELATED VACUUM HOSES</b> <ul style="list-style-type: none"> <li>• Inspect the following vacuum hoses for looseness, damage, improper connection and/or clogging.                             <ul style="list-style-type: none"> <li>— From EGR boost sensor to EGR boost sensor solenoid</li> <li>— From EGR boost sensor solenoid to intake manifold</li> </ul> </li> <li>• Are they okay?</li> </ul>	Yes	Go to next step.
		No	Repair or replace vacuum hose, then go to Step 9.
6	<b>INSPECT EGR BOOST SENSOR SOLENOID AIR FILTER FOR CLOGGING</b> <ul style="list-style-type: none"> <li>• Has EGR boost sensor solenoid air filter been clogged?</li> </ul>	Yes	Repair air clogging, then go to Step 9.
		No	Go to next step.
7	<b>INSPECT EGR BOOST SENSOR SOLENOID VALVE FOR WHETHER STUCK OPEN OR CLOSED</b> <ul style="list-style-type: none"> <li>• Inspect EGR boost sensor solenoid valve. (See 01-16-17 EGR BOOST SENSOR SOLENOID VALVE INSPECTION)</li> <li>• Is EGR boost sensor solenoid okay?</li> </ul>	Yes	Go to next step.
		No	Replace EGR boost sensor solenoid, then go to Step 9.
8	<b>INSPECT EGR BOOST SENSOR FOR WHETHER STUCK OPEN OR CLOSED</b> <ul style="list-style-type: none"> <li>• Inspect EGR boost sensor. (See 01-40A-38 EGR BOOST SENSOR INSPECTION [ZM])</li> <li>• Is EGR boost sensor okay?</li> </ul>	Yes	Go to next step.
		No	Replace EGR boost sensor, then go to next step.
9	<b>VERIFY TROUBLESHOOTING OF DTC P0106 COMPLETED</b> <ul style="list-style-type: none"> <li>• Make sure to reconnect all disconnected connectors.</li> <li>• Turn ignition key to ON (Engine OFF).</li> <li>• Clear DTC from memory using WDS or equivalent.</li> <li>• Run OBD-II DRIVE MODE 1, 2 and 3. (See 01-02A-11 OBD-II DRIVE MODE [ZM])</li> <li>• Stop vehicle.</li> <li>• Is same DTC present?</li> </ul>	Yes	Replace PCM, then go to next step.
		No	Go to next step.
10	<b>VERIFY AFTER REPAIR PROCEDURE</b> <ul style="list-style-type: none"> <li>• Perform "After Repair Procedure". (See 01-02A-10 AFTER REPAIR PROCEDURE [ZM].)</li> <li>• Is there any DTC present?</li> </ul>	Yes	Go to applicable DTC inspection. (See 01-02A-15 DTC TABLE [ZM].)
		No	Troubleshooting completed.

# ON-BOARD DIAGNOSTIC [ENGINE CONTROL SYSTEM (ZM)]

DTC P0107 [ZM]

A3U010201084W36

01-02A

<b>DTC P0107</b>	<b>BARO circuit low input</b>
<b>DETECTION CONDITION</b>	<ul style="list-style-type: none"> <li>PCM monitors input voltage from EGR boost sensor when monitoring conditions are met. If input voltage at PCM terminal 34 is <b>below 0.35 V</b>, PCM determines that EGR boost sensor circuit is malfunctioning.</li> </ul> <p><b>MONITORING CONDITIONS</b></p> <ul style="list-style-type: none"> <li>Intake air temperature is <b>above 10 °C {50 °F}</b>.</li> <li>EGR boost sensor solenoid is turned OFF. (Barometric pressure is applied to EGR boost sensor.)</li> </ul> <p><b>Diagnostic support note</b></p> <ul style="list-style-type: none"> <li>This is a continuous monitor (CCM).</li> <li>MIL illuminates if PCM detects the above malfunction condition during first drive cycle. Therefore, PENDING CODE is not available.</li> <li>FREEZE FRAME DATA is available.</li> <li>DTC is stored in PCM memory.</li> </ul>
<b>POSSIBLE CAUSE</b>	<ul style="list-style-type: none"> <li>EGR boost sensor malfunction</li> <li>Connector or terminal malfunction</li> <li>Short to ground in wiring between EGR boost sensor terminal A and PCM terminal 34</li> <li>Open circuit in wiring between EGR boost sensor terminal C and PCM terminal 90</li> <li>PCM malfunction</li> </ul>

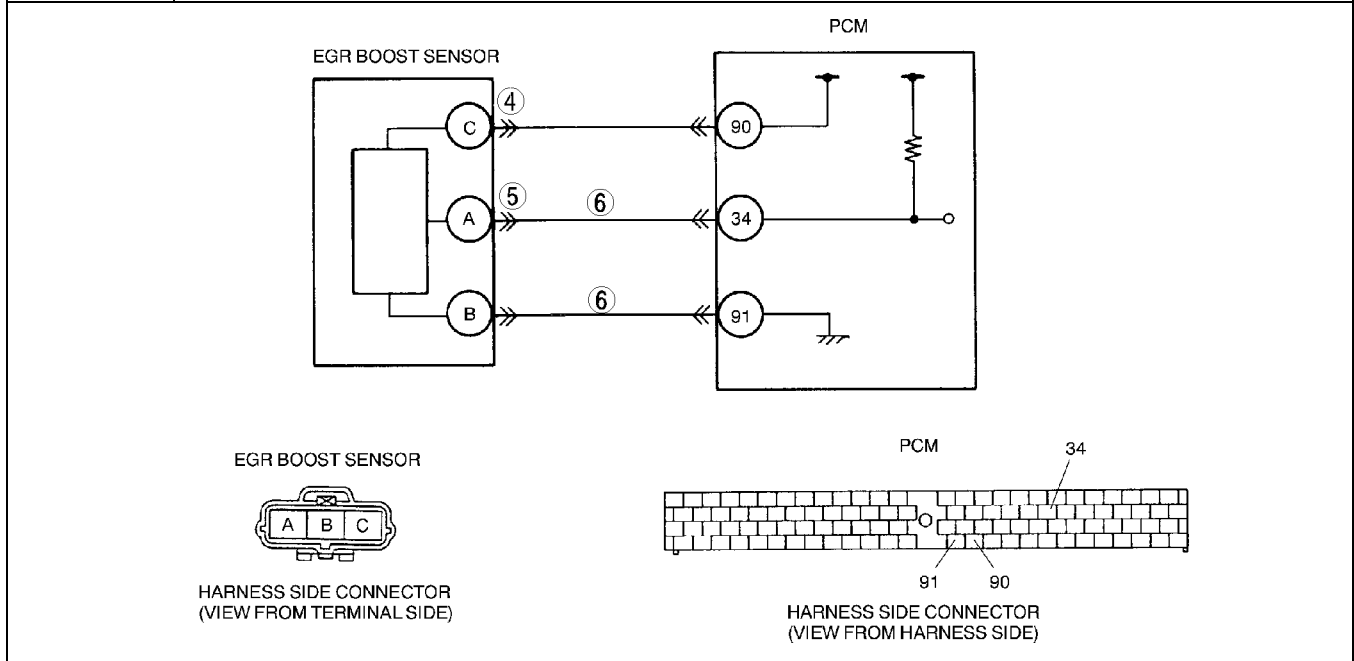

**Diagnostic procedure**

STEP	INSPECTION		ACTION
1	<b>VERIFY FREEZE FRAME DATA HAS BEEN RECORDED</b> <ul style="list-style-type: none"> <li>Has FREEZE FRAME DATA been recorded?</li> </ul>	Yes	Go to next step.
		No	Record FREEZE FRAME DATA on repair order, then go to next step.
2	<b>VERIFY RELATED REPAIR INFORMATION AVAILABILITY</b> <ul style="list-style-type: none"> <li>Check for related Service Bulletins availability.</li> <li>Is any related repair information available?</li> </ul>	Yes	Perform repair or diagnosis according to available repair information. <ul style="list-style-type: none"> <li>If vehicle is not repaired, then go to next step.</li> </ul>
		No	Go to next step.
3	<b>VERIFY SIGNAL CIRCUIT VOLTAGE WHEN EGR BOOST SENSOR CONNECTOR IS DISCONNECTED</b> <ul style="list-style-type: none"> <li>Disconnect EGR boost sensor connector.</li> <li>Turn ignition key to ON (Engine OFF).</li> <li>Measure voltage between EGR boost sensor connector terminal A (harness-side) and body GND.</li> <li>Is voltage <b>above 4.9 V</b>?</li> </ul>	Yes	Go to next step.
		No	Go to Step 5.

## ON-BOARD DIAGNOSTIC [ENGINE CONTROL SYSTEM (ZM)]

STEP	INSPECTION	ACTION	
4	<b>CHECK POWER SUPPLY CIRCUIT VOLTAGE AT EGR BOOST SENSOR CONNECTOR</b>  <b>Note</b> <ul style="list-style-type: none"> <li>• If DTCs P0122 and P0452 are also retrieved with P0107, go to REFERENCE VOLTAGE troubleshooting procedure.</li> <li>• Measure voltage between EGR boost sensor terminal C (harness-side) and body ground.</li> <li>• Is voltage <b>within 4.5—5.5 V?</b></li> </ul>	Yes	Check for poor connection of EGR boost sensor terminal C (harness-side). <ul style="list-style-type: none"> <li>• Repair or replace terminal as necessary.</li> <li>• If okay, replace EGR boost sensor.</li> </ul> Then go to Step 7.
		No	Check for open circuit between PCM terminal 90 (harness-side) and BARO terminal C (harness-side). Repair or replace suspected harness, then go to Step 7.
5	<b>INSPECT EGR BOOST SENSOR SIGNAL CIRCUIT FOR SHORT TO GROUND</b> <ul style="list-style-type: none"> <li>• Turn ignition key to OFF.</li> <li>• Disconnect PCM connector.</li> <li>• Check for continuity between EGR boost sensor terminal A (harness-side) and body ground.</li> <li>• Is there continuity?</li> </ul>	Yes	Repair or replace suspected harness, then go to next step.
		No	Go to next step.
6	<b>INSPECT EGR BOOST SENSOR SIGNAL AND GROUND CIRCUIT FOR INTERMEDIATE SHORT</b> <ul style="list-style-type: none"> <li>• Check for continuity between EGR boost sensor terminals B and A (harness-side).</li> <li>• Is there continuity?</li> </ul>	Yes	Repair or replace suspected harness, then go to next step.
		No	Go to next step.
7	<b>VERIFY TROUBLESHOOTING OF DTC P0107 COMPLETED</b> <ul style="list-style-type: none"> <li>• Make sure to reconnect all disconnected connectors.</li> <li>• Turn ignition key to ON (Engine OFF).</li> <li>• Clear DTC from memory using WDS or equivalent.</li> <li>• Start engine.</li> <li>• Is same DTC present?</li> </ul>	Yes	Replace PCM, then go to next step.
		No	No concern is detected. Go to next step.
8	<b>VERIFY AFTER REPAIR PROCEDURE</b> <ul style="list-style-type: none"> <li>• Perform "After Repair Procedure". (See 01-02A-10 AFTER REPAIR PROCEDURE [ZM].)</li> <li>• Is there any DTC present?</li> </ul>	Yes	Go to applicable DTC inspection. (See 01-02A-15 DTC TABLE [ZM].)
		No	Troubleshooting completed.

### DTC P0108 [ZM]

A3U010201084W37

DTC P0108	BARO circuit high input
<b>DETECTION CONDITION</b>	<ul style="list-style-type: none"> <li>• PCM monitors input voltage from EGR boost sensor when monitoring conditions are met. If input voltage at PCM terminal 34 is <b>above 4.92 V</b>, PCM determines that EGR boost sensor circuit is malfunctioning.</li> </ul> <b>MONITORING CONDITIONS</b> <ul style="list-style-type: none"> <li>— Intake air temperature is <b>above 10 °C {50 °F}</b>.</li> <li>— EGR boost sensor solenoid is turned OFF. (Barometric pressure is applied to EGR boost sensor.)</li> </ul> <b>Diagnostic support note</b> <ul style="list-style-type: none"> <li>• This is a continuous monitor (CCM).</li> <li>• MIL illuminates if PCM detects the above malfunction condition during first drive cycle. Therefore, PENDING CODE is not available.</li> <li>• FREEZE FRAME DATA is available.</li> <li>• DTC is stored in PCM memory.</li> </ul>
<b>POSSIBLE CAUSE</b>	<ul style="list-style-type: none"> <li>• EGR boost sensor malfunction</li> <li>• Connector or terminal malfunction</li> <li>• Open circuit in wiring between EGR boost sensor terminal B and PCM terminal 91</li> <li>• EGR boost sensor signal circuit is shorted to reference voltage (Vref) supply circuit.</li> <li>• PCM malfunction</li> </ul>

# ON-BOARD DIAGNOSTIC [ENGINE CONTROL SYSTEM (ZM)]

01-02A

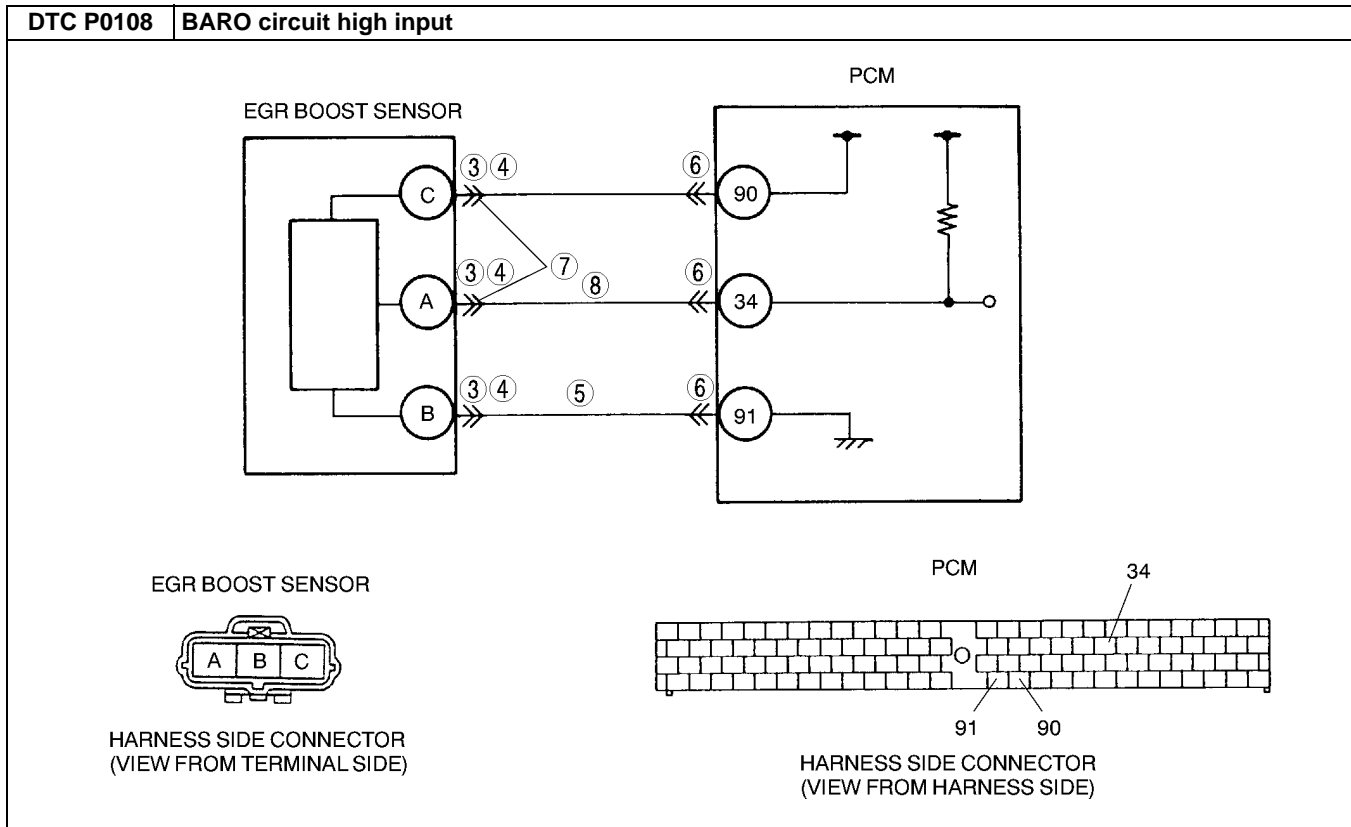

### Diagnostic procedure

STEP	INSPECTION		ACTION
1	<b>VERIFY FREEZE FRAME DATA HAS BEEN RECORDED</b> <ul style="list-style-type: none"> <li>• Has FREEZE FRAME DATA been recorded?</li> </ul>	Yes	Go to next step.
		No	Record FREEZE FRAME DATA on repair order, then go to next step.
2	<b>VERIFY RELATED REPAIR INFORMATION AVAILABILITY</b> <ul style="list-style-type: none"> <li>• Check for related Service Bulletins availability.</li> <li>• Is any related repair information available?</li> </ul>	Yes	Perform repair or diagnosis according to available repair information. <ul style="list-style-type: none"> <li>• If vehicle is not repaired, go to next step.</li> </ul>
		No	Go to next step.
3	<b>INSPECT EGR BOOST SENSOR CONNECTOR FOR CONNECTION</b> <ul style="list-style-type: none"> <li>• Turn ignition key to OFF.</li> <li>• Verify that EGR boost sensor connector is connected securely.</li> <li>• Is connection okay?</li> </ul>	Yes	Go to next step.
		No	Reconnect the connector, then go to Step 9.
4	<b>INSPECT EGR BOOST SENSOR CONNECTOR FOR POOR CONNECTION</b> <ul style="list-style-type: none"> <li>• Disconnect the EGR boost sensor connector.</li> <li>• Check for poor connection (damaged/pulled-out pins, corrosion, etc.).</li> <li>• Is there malfunction?</li> </ul>	Yes	Repair or replace suspected terminal, then go to Step 9.
		No	Go to next step.
5	<b>VERIFY EGR BOOST SENSOR GROUND CIRCUIT FOR OPEN CIRCUIT</b> <ul style="list-style-type: none"> <li>• Check for continuity between EGR boost sensor terminal B (harness-side) and body ground.</li> <li>• Is there continuity?</li> </ul>	Yes	Go to next step.
		No	Check for open circuit between PCM terminal 91 (harness-side) and EGR boost sensor terminal B (harness-side). Repair or replace suspected harness, then go to Step 9.
6	<b>CHECK PCM CONNECTOR</b> <ul style="list-style-type: none"> <li>• Disconnect PCM connector.</li> <li>• Check for poor connection at terminal 91 (damaged/pulled-out pins, corrosion, etc.).</li> <li>• Is there malfunction?</li> </ul>	Yes	Repair terminal, then go to Step 9.
		No	Go to next step.

## ON-BOARD DIAGNOSTIC [ENGINE CONTROL SYSTEM (ZM)]

STEP	INSPECTION	ACTION	
7	<b>VERIFY EGR BOOST SENSOR SIGNAL CIRCUIT FOR SHORT TO REFERENCE VOLTAGE CIRCUIT</b> <ul style="list-style-type: none"> <li>Check for continuity between EGR boost sensor terminals A and C (harness-side).</li> <li>Is there continuity?</li> </ul>	Yes	Repair or replace suspected harness, then go to Step 9.
		No	Go to next step.
8	<b>VERIFY EGR BOOST SENSOR SIGNAL CIRCUIT FOR OPEN CIRCUIT</b> <ul style="list-style-type: none"> <li>Check for continuity between EGR boost sensor terminal A (harness-side) and PCM terminal 34 (harness-side).</li> <li>Is there continuity?</li> </ul>	Yes	Go to next step.
		No	Repair or replace suspected harness, then go to next step.
9	<b>VERIFY TROUBLESHOOTING OF DTC P0108 COMPLETED</b> <ul style="list-style-type: none"> <li>Make sure to reconnect all disconnected connectors.</li> <li>Turn ignition key to ON (Engine OFF).</li> <li>Clear DTC from memory using WDS or equivalent.</li> <li>Start engine.</li> <li>Is same DTC present?</li> </ul>	Yes	Replace PCM, then go to next step.
		No	No concern is detected. Go to next step.
10	<b>VERIFY AFTER REPAIR PROCEDURE</b> <ul style="list-style-type: none"> <li>Perform "After Repair Procedure". (See 01-02A-10 AFTER REPAIR PROCEDURE [ZM].)</li> <li>Is there any DTC present?</li> </ul>	Yes	Go to applicable DTC inspection. (See 01-02A-15 DTC TABLE [ZM].)
		No	Troubleshooting completed.

### DTC P0111 [ZM]

A3U010201084W38

DTC P0111	IAT circuit performance problem
<b>DETECTION CONDITION</b>	<ul style="list-style-type: none"> <li>Intake air temperature is higher than engine coolant temperature by <b>40 °C {72 °F}</b> and ignition key is ON.</li> </ul> <b>Diagnostic support note</b> <ul style="list-style-type: none"> <li>This is a continuous monitor (CCM).</li> <li>MIL illuminates if PCM detects the above malfunction condition in two consecutive drive cycles.</li> <li>PENDING CODE is available if PCM detects the above malfunction condition during first drive cycle.</li> <li>FREEZE FRAME DATA is available.</li> <li>DTC is stored in PCM memory.</li> </ul>
<b>POSSIBLE CAUSE</b>	<ul style="list-style-type: none"> <li>IAT sensor malfunction</li> <li>Poor connection at MAF/IAT sensor or PCM connector</li> <li>PCM malfunction</li> </ul>

### Diagnostic procedure

STEP	INSPECTION	ACTION	
1	<b>VERIFY FREEZE FRAME DATA HAS BEEN RECORDED</b> <ul style="list-style-type: none"> <li>Has FREEZE FRAME DATA been recorded?</li> </ul>	Yes	Go to next step.
		No	Record FREEZE FRAME DATA on repair order, then go to next step.
2	<b>VERIFY RELATED REPAIR INFORMATION AVAILABILITY</b> <ul style="list-style-type: none"> <li>Check for related Service Bulletins availability.</li> <li>Is any related repair information available?</li> </ul>	Yes	Perform repair or diagnosis according to available repair information. <ul style="list-style-type: none"> <li>If vehicle is not repaired, go to next step.</li> </ul>
		No	Go to next step.
3	<b>INSPECT POOR CONNECTION OF MAF/IAT SENSOR CONNECTOR</b> <ul style="list-style-type: none"> <li>Turn ignition key to OFF.</li> <li>Disconnect MAF/IAT sensor connector.</li> <li>Check for poor connection (damaged/pulled-out pins, corrosion, etc.).</li> <li>Is there malfunction?</li> </ul>	Yes	Repair or replace terminal, then go to Step 6.
		No	Go to next step.
4	<b>INSPECT IAT SENSOR</b> <ul style="list-style-type: none"> <li>Measure resistance between MAF/IAT sensor terminals D and E (part-side).</li> <li>Is resistance <b>below 550 ohms</b>?</li> </ul>	Yes	Replace MAF/IAT sensor, then go to Step 6.
		No	Go to next step.



# ON-BOARD DIAGNOSTIC [ENGINE CONTROL SYSTEM (ZM)]

STEP	INSPECTION	ACTION
5	<b>INSPECT PCM CONNECTOR FOR POOR CONNECTION</b> <ul style="list-style-type: none"> <li>Disconnect PCM connector.</li> <li>Check for poor connection at terminals 39 and 91 (damaged/pulled-out pins, corrosion, etc.).</li> <li>Is there malfunction?</li> </ul>	Yes Repair or replace terminal, then go to Step 6.
		No Go to next step.
6	<b>VERIFY TROUBLESHOOTING OF DTC P0111 COMPLETED</b> <ul style="list-style-type: none"> <li>Make sure to reconnect all disconnected connectors.</li> <li>Clear DTC from PCM memory using WDS or equivalent.</li> <li>Start engine and run engine under FREEZE FRAME DATA condition.</li> <li>Is PENDING CODE of same DTC present?</li> </ul>	Yes Replace PCM, then go to next step.
		No Go to next step.
7	<b>VERIFY AFTER REPAIR PROCEDURE</b> <ul style="list-style-type: none"> <li>Perform "After Repair Procedure". (See 01-02A-10 AFTER REPAIR PROCEDURE [ZM].)</li> <li>Is there any DTC present?</li> </ul>	Yes Go to applicable DTC inspection. (See 01-02A-15 DTC TABLE [ZM].)
		No Troubleshooting completed.

01-02A

## DTC P0112 [ZM]

A3U010201084W39

DTC P0112	IAT circuit low input
<b>DETECTION CONDITION</b>	<ul style="list-style-type: none"> <li>PCM monitors IAT sensor signal at PCM terminal 39. If voltage at PCM terminal 39 is <b>below 0.15 V</b>, PCM determines that IAT sensor circuit has malfunction.</li> </ul> <p><b>Diagnostic support note</b></p> <ul style="list-style-type: none"> <li>This is a continuous monitor (CCM).</li> <li>MIL illuminates if PCM detects the above malfunction condition during first drive cycle. Therefore, PENDING CODE is not available.</li> <li>FREEZE FRAME DATA is available.</li> <li>DTC is stored in PCM memory.</li> </ul>
<b>POSSIBLE CAUSE</b>	<ul style="list-style-type: none"> <li>IAT sensor malfunction</li> <li>Short to ground circuit between MAF/IAT sensor terminal D and PCM terminal 39</li> <li>IAT signal and IAT ground circuits are shorted each other.</li> <li>PCM malfunction</li> </ul>

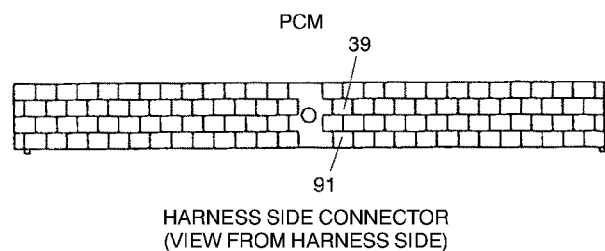
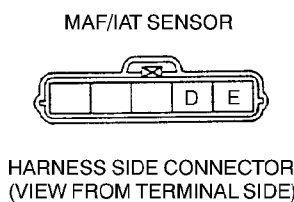
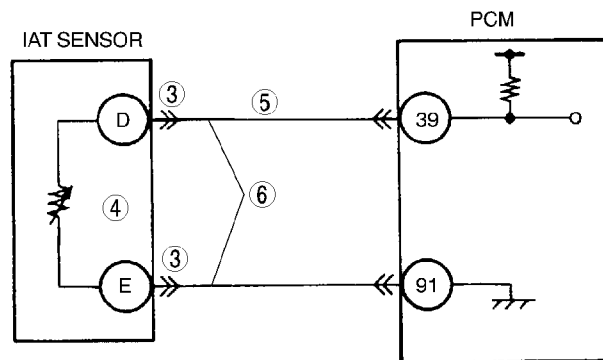

## ON-BOARD DIAGNOSTIC [ENGINE CONTROL SYSTEM (ZM)]

### Diagnostic procedure

STEP	INSPECTION	ACTION
1	<b>VERIFY FREEZE FRAME DATA HAS BEEN RECORDED</b> <ul style="list-style-type: none"> <li>Has FREEZE FRAME DATA been recorded?</li> </ul>	Yes Go to next step.
		No Record FREEZE FRAME DATA on repair order, then go to next step.
2	<b>VERIFY RELATED REPAIR INFORMATION AVAILABILITY</b> <ul style="list-style-type: none"> <li>Check for related Service Bulletins availability.</li> <li>Is any related repair information available?</li> </ul>	Yes Perform repair or diagnosis according to available repair information. • If vehicle is not repaired, then go to next step.
		No Go to next step.
3	<b>INSPECT IAT SENSOR TERMINAL</b> <ul style="list-style-type: none"> <li>Turn ignition key to OFF.</li> <li>Disconnect MAF/IAT sensor connector.</li> <li>Check for bent terminals of MAF/IAT sensor terminals E and D (part-side).</li> <li>Is there malfunction?</li> </ul>	Yes Repair or replace terminal, then go to Step 7.
		No Go to next step.
4	<b>CLASSIFY IAT SENSOR MALFUNCTION OR HARNESS MALFUNCTION</b> <ul style="list-style-type: none"> <li>Disconnect MAF/IAT sensor connector.</li> <li>Measure resistance between IAT sensor terminals E and D (part-side).</li> <li>Is resistance <b>within 0.117—28.616 kilohms</b>?</li> </ul>	Yes Go to next step.
		No Replace MAF/IAT sensor, then go to Step 7.
5	<b>INSPECT IAT SIGNAL CIRCUIT FOR SHORT TO GROUND</b> <ul style="list-style-type: none"> <li>Disconnect PCM connector.</li> <li>Check for continuity between MAF/IAT sensor terminal D (harness-side) and body ground.</li> <li>Is there continuity?</li> </ul>	Yes Repair or replace harness for short to ground, then go to Step 7.
		No Go to next step.
6	<b>INSPECT IAT CIRCUITS FOR INTERMEDIATE SHORT</b> <ul style="list-style-type: none"> <li>Check for continuity between MAF/IAT sensor terminals D and E (harness-side).</li> <li>Is there continuity?</li> </ul>	Yes Repair or replace harness for short, then go to Step 7.
		No Go to next step.
7	<b>VERIFY TROUBLESHOOTING OF DTC P0112 COMPLETED</b> <ul style="list-style-type: none"> <li>Make sure to reconnect all disconnected connectors.</li> <li>Clear DTC from PCM memory using WDS or equivalent.</li> <li>Start engine.</li> <li>Is same DTC present?</li> </ul>	Yes Replace PCM, then go to next step.
		No No concern is detected. Go to next step.
8	<b>VERIFY AFTER REPAIR PROCEDURE</b> <ul style="list-style-type: none"> <li>Perform "After Repair Procedure". (See 01-02A-10 AFTER REPAIR PROCEDURE [ZM].)</li> <li>Is there any DTC present?</li> </ul>	Yes Go to applicable DTC inspection. (See 01-02A-15 DTC TABLE [ZM].)
		No Troubleshooting completed.

### DTC P0113 [ZM]

A3U010201084W40

DTC P0113	IAT circuit high input
<b>DETECTION CONDITION</b>	<ul style="list-style-type: none"> <li>The PCM monitors IAT sensor signal at PCM terminal 39. If voltage at PCM terminal 39 is <b>above 4.84 V</b>, PCM determines that IAT sensor circuit has malfunction.</li> </ul> <p><b>Diagnostic support note</b></p> <ul style="list-style-type: none"> <li>This is a continuous monitor (CCM).</li> <li>MIL illuminates if PCM detects the above malfunction condition during first drive cycle. Therefore, PENDING CODE is not available.</li> <li>FREEZE FRAME DATA is available.</li> <li>DTC is not stored in PCM memory.</li> </ul>
<b>POSSIBLE CAUSE</b>	<ul style="list-style-type: none"> <li>IAT sensor malfunction</li> <li>Open circuit between MAF/IAT sensor terminal D and PCM terminal 39</li> <li>Short to power circuit between MAF/IAT sensor terminal D and PCM terminal 39</li> <li>Open circuit between MAF/IAT sensor terminal E and PCM terminal 91</li> <li>Short to power circuit between MAF/IAT sensor terminal E and PCM terminal 91</li> <li>Poor connection at MAF/IAT sensor or PCM connector</li> <li>PCM malfunction</li> </ul>

# ON-BOARD DIAGNOSTIC [ENGINE CONTROL SYSTEM (ZM)]

01-02A

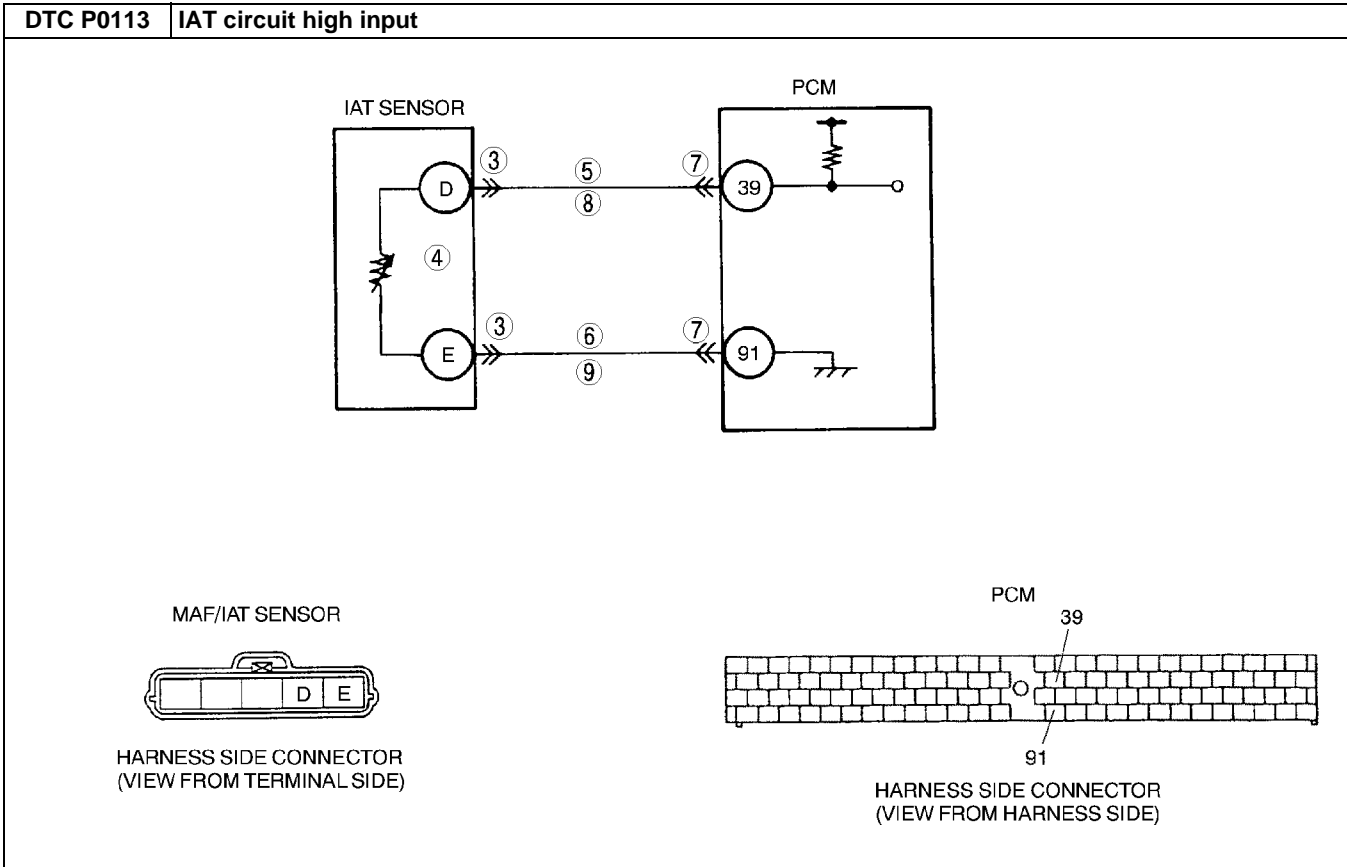

### Diagnostic procedure

STEP	INSPECTION		ACTION
1	<b>VERIFY FREEZE FRAME DATA HAS BEEN RECORDED</b> • Has FREEZE FRAME DATA been recorded?	Yes	Go to next step.
		No	Record FREEZE FRAME DATA on repair order, then go to next step.
2	<b>VERIFY RELATED REPAIR INFORMATION AVAILABILITY</b> • Check for related Service Bulletins availability. • Is any related repair information available?	Yes	Perform repair or diagnosis according to available repair information. • If vehicle is not repaired, go to next step.
		No	Go to next step.
3	<b>INSPECT IAT SENSOR CONNECTOR FOR POOR CONNECTION</b> • Turn ignition key to OFF. • Disconnect MAF/IAT sensor connector. • Check for poor connection (damaged/pulled-out pins, corrosion, etc.). • Is there malfunction?	Yes	Repair or replace terminal, then go to Step 10.
		No	Go to next step.
4	<b>INSPECT IAT SENSOR</b> • Disconnect MAF/IAT sensor connector. • Measure resistance between IAT sensor terminals E and D (part-side). • Is resistance <b>within 0.117—28.616 kilohms</b> ?	Yes	Replace MAF/IAT sensor, then go to Step 10.
		No	Go to next step.
5	<b>INSPECT IAT SENSOR SIGNAL CIRCUIT FOR SHORT TO POWER</b> • Turn ignition key to ON (Engine OFF). • Measure voltage between MAF/IAT sensor terminal E (harness-side) and body ground. • Is there voltage <b>B+</b> ?	Yes	Repair or replace harness for short to power, then go to Step 10.
		No	Go to next step.
6	<b>INSPECT IAT SENSOR GROUND CIRCUIT FOR SHORT TO POWER</b> • Measure voltage between MAF/IAT sensor terminal D (harness-side) and body ground. • Is voltage <b>B+</b> ?	Yes	Repair or replace harness for short to power, then go to Step 10.
		No	Go to next step.

## ON-BOARD DIAGNOSTIC [ENGINE CONTROL SYSTEM (ZM)]

STEP	INSPECTION	ACTION	
7	<b>INSPECT PCM CONNECTOR FOR POOR CONNECTION</b> <ul style="list-style-type: none"> <li>• Turn ignition key to OFF.</li> <li>• Disconnect PCM connector.</li> <li>• Inspect PCM terminal 39 and 91 (harness-side) for tightness using feeler tool.</li> <li>• Is there malfunction?</li> </ul>	Yes	Repair or replace terminal, then go to Step 10.
		No	Go to next step.
8	<b>INSPECT IAT SENSOR SIGNAL CIRCUIT FOR OPEN CIRCUIT</b> <ul style="list-style-type: none"> <li>• Connect breakout box with PCM disconnected.</li> <li>• Check for continuity between MAF/IAT sensor terminal D (harness-side) and breakout box terminal 39.</li> <li>• Is there continuity?</li> </ul>	Yes	Go to next step.
		No	Repair or replace harness for open, then go to Step 10.
9	<b>INSPECT IAT SENSOR GROUND CIRCUIT FOR OPEN CIRCUIT</b> <ul style="list-style-type: none"> <li>• Check for continuity between MAF/IAT sensor terminal E (harness-side) and breakout box terminal 91.</li> <li>• Is there continuity?</li> </ul>	Yes	Go to next step.
		No	Repair or replace harness for open, then go to next step.
10	<b>VERIFY TROUBLESHOOTING OF DTC P0113 COMPLETED</b> <ul style="list-style-type: none"> <li>• Make sure to reconnect all disconnected connectors.</li> <li>• Clear DTC from PCM memory using WDS or equivalent.</li> <li>• Start engine.</li> <li>• Is same DTC present?</li> </ul>	Yes	Replace PCM, then go to next step.
		No	No concern is detected. Go to next step.
11	<b>VERIFY AFTER REPAIR PROCEDURE</b> <ul style="list-style-type: none"> <li>• Perform "After Repair Procedure". (See 01-02A-10 AFTER REPAIR PROCEDURE [ZM].)</li> <li>• Is there any DTC present?</li> </ul>	Yes	Go to applicable DTC inspection. (See 01-02A-15 DTC TABLE [ZM].)
		No	Troubleshooting completed.

# ON-BOARD DIAGNOSTIC [ENGINE CONTROL SYSTEM (ZM)]

DTC P0117 [ZM]

A3U010201084W41

01-02A

<b>DTC P0117</b>	<b>ECT circuit low input</b>
<b>DETECTION CONDITION</b>	<ul style="list-style-type: none"> <li>PCM monitors ECT sensor signal at PCM terminal 38. If voltage at terminal 38 is <b>below 0.20 V</b>, PCM determines that ECT sensor circuit has malfunction.</li> </ul> <p><b>Diagnostic support note</b></p> <ul style="list-style-type: none"> <li>This is a continuous monitor (CCM).</li> <li>MIL illuminates if PCM detects the above malfunction condition during first drive cycle. Therefore, PENDING CODE is not available.</li> <li>FREEZE FRAME DATA is available.</li> <li>DTC is stored in PCM memory.</li> </ul>
<b>POSSIBLE CAUSE</b>	<ul style="list-style-type: none"> <li>ECT sensor malfunction</li> <li>Short to ground circuit between ECT sensor terminal A and PCM connector terminal 38</li> <li>ECT signal and ground circuits are shorted each other.</li> <li>PCM malfunction</li> </ul>

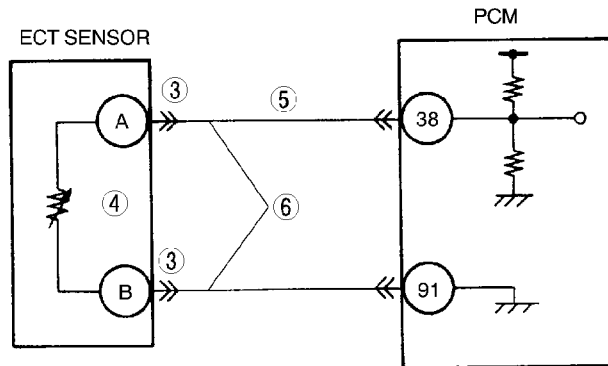

ECT SENSOR

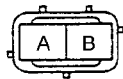

HARNESS SIDE CONNECTOR  
(VIEW FROM TERMINAL SIDE)

PCM

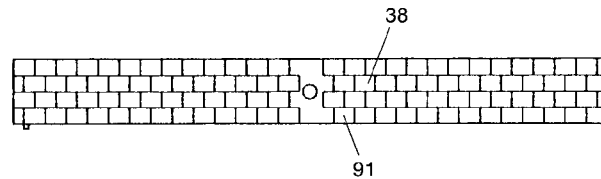

HARNESS SIDE CONNECTOR  
(VIEW FROM HARNESS SIDE)

**Diagnostic procedure**

STEP	INSPECTION		ACTION
1	<b>VERIFY FREEZE FRAME DATA HAS BEEN RECORDED</b> <ul style="list-style-type: none"> <li>Has FREEZE FRAME DATA been recorded?</li> </ul>	Yes	Go to next step.
		No	Record FREEZE FRAME DATA on repair order, then go to next step.
2	<b>VERIFY RELATED REPAIR INFORMATION AVAILABILITY</b> <ul style="list-style-type: none"> <li>Check for related Service Bulletins availability.</li> <li>Is any related repair information available?</li> </ul>	Yes	Perform repair or diagnosis according to available repair information. <ul style="list-style-type: none"> <li>If vehicle is not repaired, go to next step.</li> </ul>
		No	Go to next step.
3	<b>INSPECT TERMINAL FOR BENDING</b> <ul style="list-style-type: none"> <li>Turn ignition key to OFF.</li> <li>Disconnect ECT sensor connector.</li> <li>Check for bent of ECT sensor terminals A and B (part-side).</li> <li>Is there malfunction?</li> </ul>	Yes	Repair or replace terminal, then go to Step 7.
		No	Go to next step.
4	<b>CLASSIFY ECT SENSOR MALFUNCTION OR HARNESS MALFUNCTION</b> <ul style="list-style-type: none"> <li>Measure resistance between ECT sensor terminals A and B (part-side).</li> <li>Is resistance <b>within 0.111—25.403 kilohms</b>?</li> </ul>	Yes	Go to next step.
		No	Replace ECT sensor, then go to Step 7.

## ON-BOARD DIAGNOSTIC [ENGINE CONTROL SYSTEM (ZM)]

STEP	INSPECTION	ACTION	
5	<b>INSPECT ECT SIGNAL CIRCUIT FOR SHORT TO GROUND</b> <ul style="list-style-type: none"> <li>• Turn ignition key to OFF.</li> <li>• Disconnect PCM connector.</li> <li>• Check for continuity between ECT sensor terminal A (harness-side) and body ground.</li> <li>• Is there continuity?</li> </ul>	Yes	Repair or replace harness for short to ground, then go to Step 7.
		No	Go to next step.
6	<b>INSPECT ECT CIRCUIT FOR SHORT</b> <ul style="list-style-type: none"> <li>• Check for continuity between ECT sensor terminals A and B (harness-side).</li> <li>• Is there continuity?</li> </ul>	Yes	Repair or replace harness for short, then go to next step.
		No	Go to next step.
7	<b>VERIFY TROUBLESHOOTING OF DTC P0117 COMPLETED</b> <ul style="list-style-type: none"> <li>• Make sure to reconnect all disconnected connectors.</li> <li>• Clear DTC from PCM memory using WDS or equivalent.</li> <li>• Start engine.</li> <li>• Is same DTC present?</li> </ul>	Yes	Replace PCM, then go to next step.
		No	Go to next step.
8	<b>VERIFY AFTER REPAIR PROCEDURE</b> <ul style="list-style-type: none"> <li>• Perform "After Repair Procedure". (See 01-02A-10 AFTER REPAIR PROCEDURE [ZM].)</li> <li>• Is there any DTC present?</li> </ul>	Yes	Go to applicable DTC inspection. (See 01-02A-15 DTC TABLE [ZM].)
		No	Troubleshooting completed.

# ON-BOARD DIAGNOSTIC [ENGINE CONTROL SYSTEM (ZM)]

DTC P0118 [ZM]

A3U010201084W42

01-02A

<b>DTC P0118</b>	<b>ECT circuit high input</b>
<b>DETECTION CONDITION</b>	<ul style="list-style-type: none"> <li>PCM monitors ECT sensor signal at PCM terminal 38. If voltage at terminal 38 is <b>above 4.94 V</b>, PCM determines that ECT sensor circuit has malfunction.</li> </ul> <p><b>Diagnostic support note</b></p> <ul style="list-style-type: none"> <li>This is a continuous monitor (CCM).</li> <li>MIL illuminates if PCM detects the above malfunction condition during first drive cycle. Therefore, PENDING CODE is not available.</li> <li>FREEZE FRAME DATA is available.</li> <li>DTC is stored in PCM memory.</li> </ul>
<b>POSSIBLE CAUSE</b>	<ul style="list-style-type: none"> <li>ECT sensor malfunction</li> <li>Open circuit between ECT sensor terminal A and PCM terminal 38</li> <li>Short to power circuit between ECT sensor terminal A and PCM terminal 38</li> <li>Open circuit between ECT sensor terminal B and PCM terminal 91</li> <li>Poor connection of ECT sensor or PCM connectors</li> <li>PCM malfunction</li> </ul>

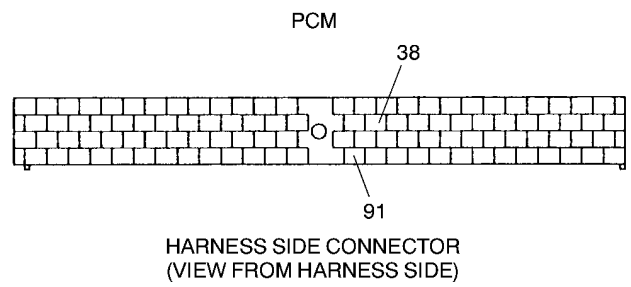
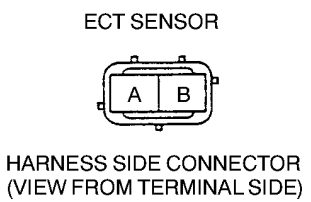
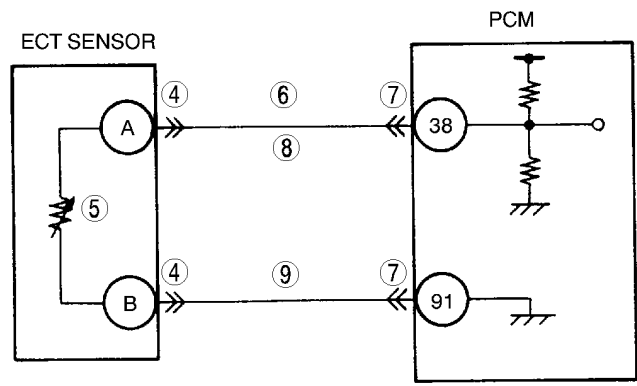

**Diagnostic procedure**

STEP	INSPECTION		ACTION
1	<b>VERIFY FREEZE FRAME DATA HAS BEEN RECORDED</b> <ul style="list-style-type: none"> <li>Has FREEZE FRAME DATA been recorded?</li> </ul>	Yes	Go to next step.
		No	Record FREEZE FRAME DATA on repair order, then go to next step.
2	<b>VERIFY RELATED REPAIR INFORMATION AVAILABILITY</b> <ul style="list-style-type: none"> <li>Check for related Service Bulletins availability.</li> <li>Is any related repair information available?</li> </ul>	Yes	Perform repair or diagnosis according to available repair information. <ul style="list-style-type: none"> <li>If vehicle is not repaired, go to next step.</li> </ul>
		No	Go to next step.
3	<b>INSPECT ECT SENSOR CONNECTOR FOR POOR CONNECTION</b> <ul style="list-style-type: none"> <li>Turn ignition key to OFF.</li> <li>Disconnect ECT sensor connector.</li> <li>Check for poor connection (damaged/pulled-out pins, corrosion, etc.).</li> <li>Is there malfunction?</li> </ul>	Yes	Repair or replace terminal, then go to Step 10.
		No	Go to next step.

## ON-BOARD DIAGNOSTIC [ENGINE CONTROL SYSTEM (ZM)]

STEP	INSPECTION	ACTION	
4	<b>CLASSIFY ECT SENSOR OR HARNESS MALFUNCTION</b> <ul style="list-style-type: none"> <li>• Measure resistance between ECT sensor terminals A and B (part-side).</li> <li>• Is resistance <b>within 0.111—25.403 kilohms?</b></li> </ul>	Yes	Go to next step.
		No	Replace ECT sensor, then go to Step 10.
5	<b>INSPECT ECT SENSOR SIGNAL CIRCUIT FOR SHORT TO POWER</b> <ul style="list-style-type: none"> <li>• Turn ignition key to ON (Engine OFF).</li> <li>• Measure voltage between ECT sensor terminal A (harness-side) and body ground.</li> <li>• Is there voltage <b>B+</b>?</li> </ul>	Yes	Repair or replace harness for short to power, then go to Step 10.
		No	Go to next step.
6	<b>INSPECT PCM CONNECTOR FOR POOR CONNECTION</b> <ul style="list-style-type: none"> <li>• Disconnect PCM connector.</li> <li>• Check for poor connection at terminals 38 and 91 (damaged/pulled-out pins, corrosion, etc.).</li> <li>• Is there malfunction?</li> </ul>	Yes	Repair or replace terminal, then go to Step 10.
		No	Go to next step.
7	<b>INSPECT ECT SENSOR SIGNAL CIRCUIT FOR OPEN CIRCUIT</b> <ul style="list-style-type: none"> <li>• Connect breakout box with PCM disconnected.</li> <li>• Check for continuity between ECT sensor terminal A (harness-side) and breakout box terminal 38.</li> <li>• Is there continuity?</li> </ul>	Yes	Go to next step.
		No	Repair or replace harness for open, then go to Step 10.
8	<b>INSPECT ECT SENSOR GROUND CIRCUIT FOR OPEN CIRCUIT</b> <ul style="list-style-type: none"> <li>• Check for continuity between ECT sensor terminal B (harness-side) and breakout box terminal 91.</li> <li>• Is there continuity?</li> </ul>	Yes	Go to next step.
		No	Repair or replace harness for open, then go to next step.
9	<b>VERIFY TROUBLESHOOTING OF DTC P0118 COMPLETED</b> <ul style="list-style-type: none"> <li>• Make sure to reconnect all disconnected connectors.</li> <li>• Clear DTC from PCM memory using WDS or equivalent.</li> <li>• Start engine.</li> <li>• Is same DTC present?</li> </ul>	Yes	Replace PCM, then go to next step.
		No	No concern is detected. Go to next step.
10	<b>VERIFY AFTER REPAIR PROCEDURE</b> <ul style="list-style-type: none"> <li>• Perform "After Repair Procedure". (See 01–02A–10 AFTER REPAIR PROCEDURE [ZM].)</li> <li>• Is there any DTC present?</li> </ul>	Yes	Go to applicable DTC inspection. (See 01–02A–15 DTC TABLE [ZM].)
		No	Troubleshooting completed.

### DTC P0122 [ZM]

A3U010201084W43

DTC P0122	TP circuit low input
<b>DETECTION CONDITION</b>	<ul style="list-style-type: none"> <li>• If PCM detects TP sensor voltage at PCM terminal 89 <b>below 0.10 V</b> after engine start, PCM determines that TP circuit has a malfunction.</li> </ul> <p><b>Diagnostic support note</b></p> <ul style="list-style-type: none"> <li>• This is a continuous monitor (CCM).</li> <li>• MIL illuminates if PCM detects the above malfunction conditions during first drive cycle. Therefore, PENDING CODE is not available.</li> <li>• FREEZE FRAME DATA is available.</li> <li>• DTC is stored in PCM memory.</li> </ul>
<b>POSSIBLE CAUSE</b>	<ul style="list-style-type: none"> <li>• TP sensor malfunction</li> <li>• Connector or terminal malfunction</li> <li>• Open circuit between TP sensor terminal C and PCM terminal 89</li> <li>• Short to ground circuit between TP sensor terminal C and PCM terminal 89</li> <li>• Open circuit between TP sensor terminal A and PCM terminal 90</li> <li>• Short to ground circuit between TP sensor terminal A and PCM terminal 90</li> <li>• PCM malfunction</li> </ul>



# ON-BOARD DIAGNOSTIC [ENGINE CONTROL SYSTEM (ZM)]

01-02A

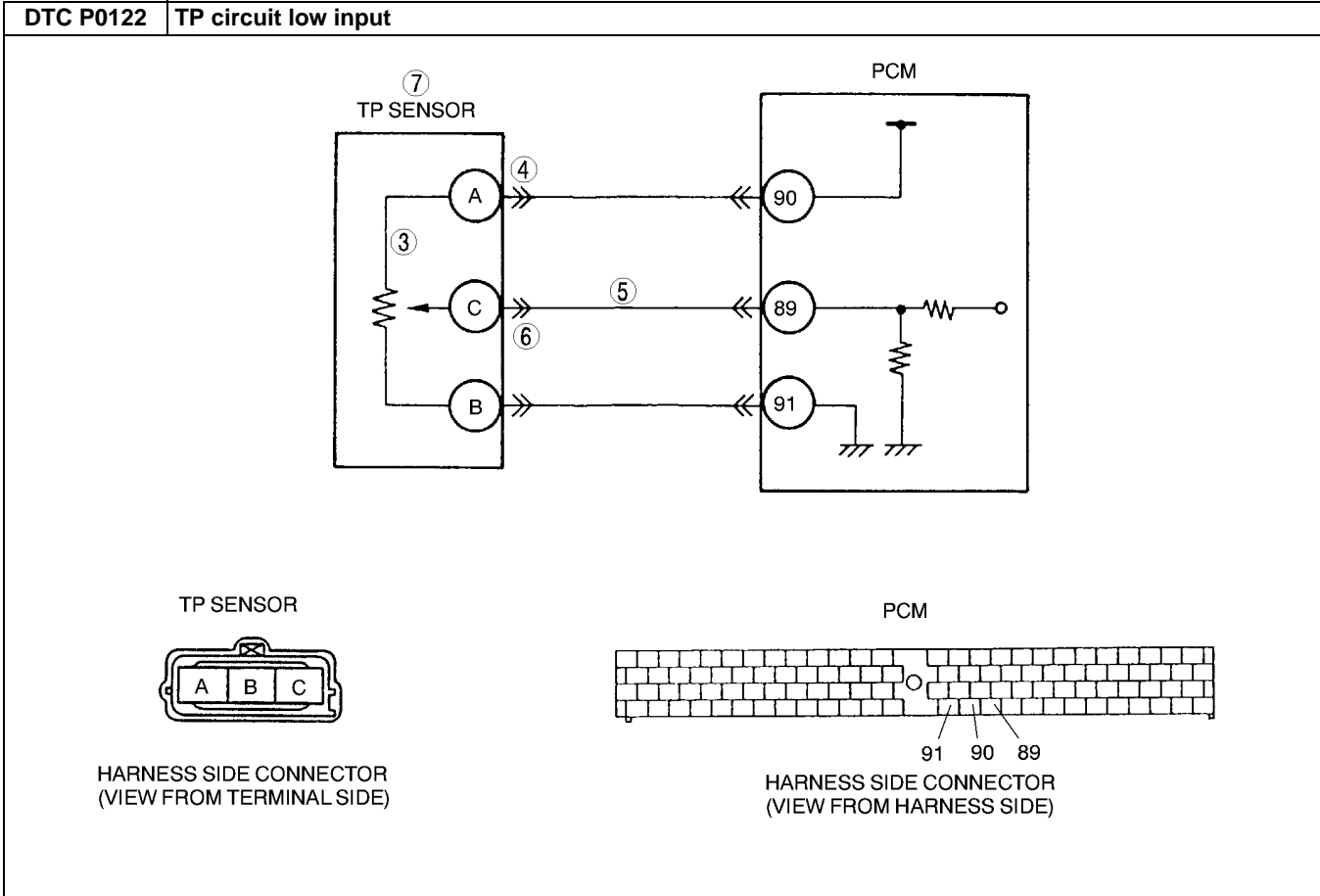

**Diagnostic procedure**

STEP	INSPECTION		ACTION
1	<b>VERIFY FREEZE FRAME DATA HAS BEEN RECORDED</b> <ul style="list-style-type: none"> <li>Has FREEZE FRAME DATA been recorded?</li> </ul>	Yes	Go to next step.
		No	Record FREEZE FRAME DATA on repair order, then go to next step.
2	<b>VERIFY RELATED REPAIR INFORMATION AVAILABILITY</b> <ul style="list-style-type: none"> <li>Check for related Service Bulletins availability.</li> <li>Is any related repair information available?</li> </ul>	Yes	Perform repair or diagnosis according to available repair information. <ul style="list-style-type: none"> <li>If vehicle is not repaired, go to next step.</li> </ul>
		No	Go to next step.
3	<b>CHECK TP SENSOR CIRCUIT FOR OPEN CIRCUIT</b> <ul style="list-style-type: none"> <li>Turn ignition key to OFF.</li> <li>Check for continuity between TP sensor terminals A and C (part-side).</li> <li>Is there continuity?</li> </ul>	Yes	Check TP sensor connector terminal A for poor connection. Repair or replace as necessary, then go to Step 8.
		No	Go to Step 8.
4	<b>CHECK POWER SUPPLY CIRCUIT VOLTAGE AT TP SENSOR CONNECTOR</b> <p><b>Note</b></p> <ul style="list-style-type: none"> <li>If DTC P0107 and P0452 are also retrieved with P0122, go to REFERENCE VOLTAGE troubleshooting procedure. (See 01-03A-50 NO.30 CONSTANT VOLTAGE [ZM].)</li> </ul> <ul style="list-style-type: none"> <li>Turn ignition key to ON (Engine OFF).</li> <li>Check voltage at TP sensor terminal A (harness-side).</li> <li>Is voltage <b>within 4.5—5.5 V</b>?</li> </ul>	Yes	Go to next step.
		No	Repair or replace open circuit in wiring harness between TP sensor terminal A (harness-side) and PCM terminal 90 (harness-side), then go to Step 8.

## ON-BOARD DIAGNOSTIC [ENGINE CONTROL SYSTEM (ZM)]

STEP	INSPECTION	ACTION	
5	<b>VERIFY TP SIGNAL CIRCUIT FOR OPEN CIRCUIT</b> <ul style="list-style-type: none"> <li>• Turn ignition key to OFF.</li> <li>• Disconnect PCM connector.</li> <li>• Connect breakout box with PCM disconnected.</li> <li>• Disconnect TP sensor connector.</li> <li>• Check for continuity between TP sensor terminal C (harness-side) and breakout box terminal 89.</li> <li>• Is there continuity?</li> </ul>	Yes	Go to next step.
		No	Repair or replace suspected harness, then go to Step 8.
6	<b>VERIFY TP SIGNAL CIRCUIT FOR SHORT TO GROUND</b> <ul style="list-style-type: none"> <li>• Check for continuity between TP sensor connector terminal C and body ground.</li> <li>• Is there continuity?</li> </ul>	Yes	Repair or replace suspected harness, then go to Step 8.
		No	Go to next step.
7	<b>INSPECT TP SENSOR</b> <ul style="list-style-type: none"> <li>• Perform TP sensor inspection. (See 01-40A-28 THROTTLE POSITION (TP) SENSOR INSPECTION [ZM].)</li> <li>• Is TP sensor Okay?</li> </ul>	Yes	Go to next step.
		No	Replace TP sensor.
8	<b>VERIFY TROUBLESHOOTING OF DTC P0122 COMPLETED</b> <ul style="list-style-type: none"> <li>• Make sure to reconnect all disconnected connectors.</li> <li>• Start engine.</li> <li>• Clear DTC from PCM memory using WDS or equivalent.</li> <li>• Depress and release accelerator pedal several times.</li> <li>• Is same DTC present?</li> </ul>	Yes	Replace PCM, then go to next step.
		No	Go to next step.
9	<b>VERIFY AFTER REPAIR PROCEDURE</b> <ul style="list-style-type: none"> <li>• Perform "After Repair Procedure". (See 01-02A-10 AFTER REPAIR PROCEDURE [ZM].)</li> <li>• Is there any DTC present?</li> </ul>	Yes	Go to applicable DTC inspection. (See 01-02A-15 DTC TABLE [ZM].)
		No	Troubleshooting completed.

# ON-BOARD DIAGNOSTIC [ENGINE CONTROL SYSTEM (ZM)]

DTC P0123 [ZM]

A3U010201084W44

01-02A

<b>DTC P0123</b>	<b>TP circuit high input</b>
<b>DETECTION CONDITION</b>	<ul style="list-style-type: none"> <li>If PCM detects TP sensor voltage at PCM terminal 89 is <b>above 4.77 V</b> after engine start, PCM determines that TP circuit has a malfunction.</li> </ul> <p><b>Diagnostic support note</b></p> <ul style="list-style-type: none"> <li>This is a continuous monitor (CCM).</li> <li>MIL illuminates if PCM detects the above malfunction conditions during first drive cycle. Therefore, PENDING CODE is not available.</li> <li>FREEZE FRAME DATA is available.</li> <li>DTC is stored in PCM memory.</li> </ul>
<b>POSSIBLE CAUSE</b>	<ul style="list-style-type: none"> <li>TP sensor malfunction</li> <li>Connector or terminal malfunction</li> <li>Open circuit between TP sensor terminal B and PCM terminal 91</li> <li>Short to reference voltage (Vref) supply circuit between TP sensor terminal C and PCM terminal 89</li> <li>PCM malfunction</li> </ul>

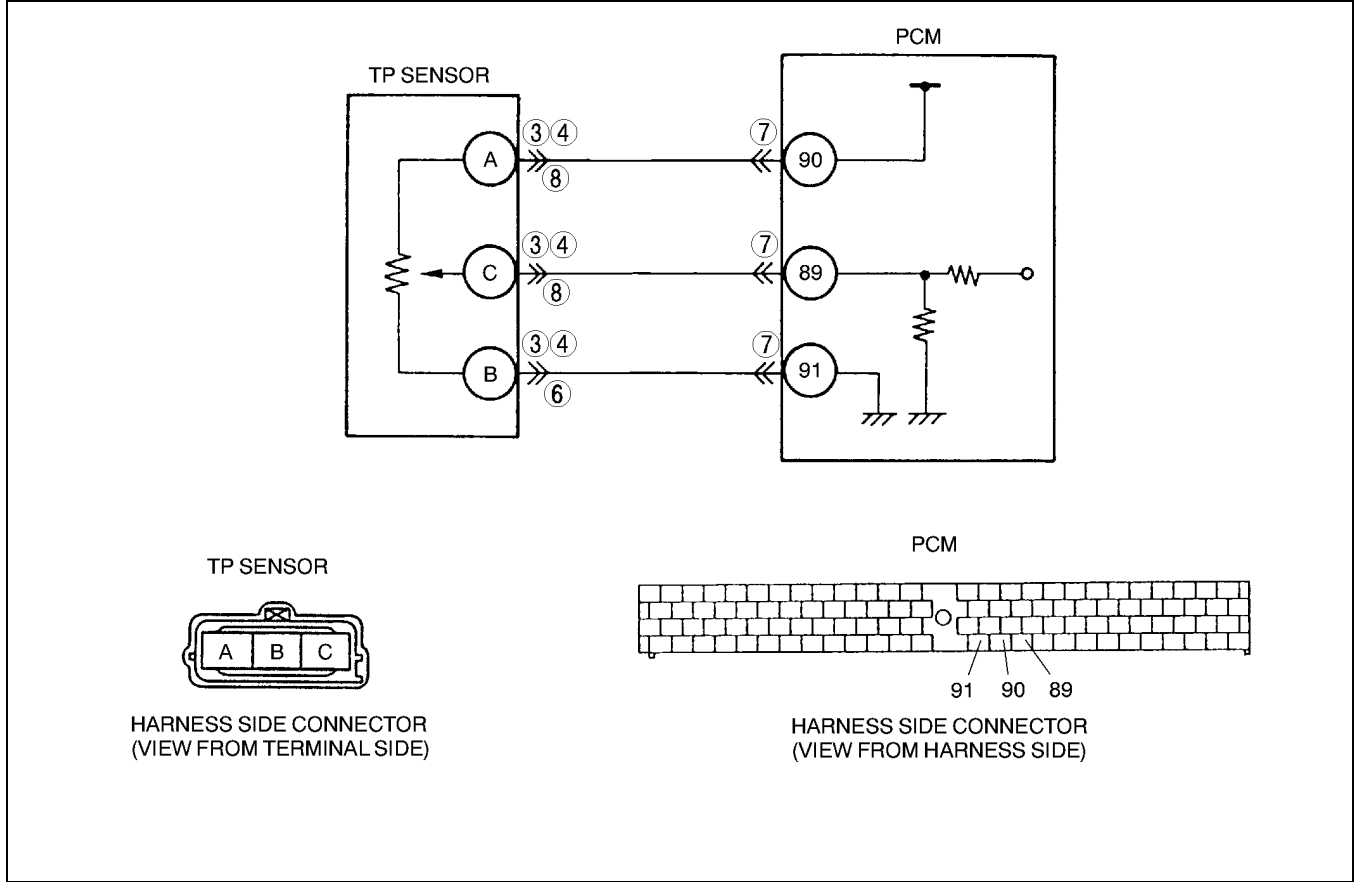

**Diagnostic procedure**

STEP	INSPECTION		ACTION
1	<b>VERIFY FREEZE FRAME DATA HAS BEEN RECORDED</b> <ul style="list-style-type: none"> <li>Has FREEZE FRAME DATA been recorded?</li> </ul>	Yes	Go to next step.
		No	Record FREEZE FRAME DATA on repair order, then go to next step.
2	<b>VERIFY RELATED REPAIR INFORMATION AVAILABILITY</b> <ul style="list-style-type: none"> <li>Check for related Service Bulletins availability.</li> <li>Is any related repair information available?</li> </ul>	Yes	Perform repair or diagnosis according to available repair information. <ul style="list-style-type: none"> <li>If vehicle is not repaired, go to next step.</li> </ul>
		No	Go to next step.
3	<b>CHECK TP SENSOR CONNECTOR</b> <ul style="list-style-type: none"> <li>Turn ignition key to OFF.</li> <li>Verify that the TP sensor connector is connected securely.</li> <li>Is connector okay?</li> </ul>	Yes	Go to next step.
		No	Connect the connector securely, then go to Step 9.

## ON-BOARD DIAGNOSTIC [ENGINE CONTROL SYSTEM (ZM)]

STEP	INSPECTION	ACTION	
4	<b>INSPECT TP SENSOR CONNECTOR FOR POOR CONNECTION</b> <ul style="list-style-type: none"> <li>• Disconnect TP sensor connector.</li> <li>• Check for poor connection (damaged/pulled-out terminals, corrosion, etc.).</li> <li>• Is there any malfunction?</li> </ul>	Yes	Repair or replace suspected terminal, then go to Step 9.
		No	Go to next step.
5	<b>CHECK TP SENSOR RESISTANCE</b> <ul style="list-style-type: none"> <li>• Check resistance between following TP sensor terminals (part-side): Terminals A and B: <b>Within 3.2—4.8 kilohms</b> Terminals B and C: <b>Within 0.2—1.2 kilohms</b></li> <li>• Are both resistances within specifications?</li> </ul>	Yes	Go to next step.
		No	Replace TP sensor, then go to Step 9.
6	<b>VERIFY TP SENSOR GROUND CIRCUIT FOR OPEN CIRCUIT AT TP SENSOR CONNECTOR</b> <ul style="list-style-type: none"> <li>• Check for continuity between TP sensor terminal B (harness-side) and body ground.</li> <li>• Is there continuity?</li> </ul>	Yes	Go to Step 8.
		No	Go to next step.
7	<b>CHECK PCM CONNECTOR</b> <ul style="list-style-type: none"> <li>• Disconnect PCM connector.</li> <li>• Check for poor connection at terminals 89, 90 and 91 (damaged/pulled-out terminals, corrosion, etc.).</li> <li>• Is there any malfunction?</li> </ul>	Yes	Repair terminal, then go to Step 9.
		No	Repair or replace open circuit in wiring harness between TP sensor terminal B and PCM connector terminal 91 (harness-side). Then, go to Step 9.
8	<b>VERIFY TP SIGNAL CIRCUIT FOR SHORT TO CONSTANT VOLTAGE CIRCUIT</b> <ul style="list-style-type: none"> <li>• Check for continuity between TP sensor terminals A and C.</li> <li>• Is there continuity?</li> </ul>	Yes	Repair or replace suspected harness, then go to next step.
		No	Go to next step.
9	<b>VERIFY TROUBLESHOOTING OF DTC P0123 COMPLETED</b> <ul style="list-style-type: none"> <li>• Make sure to reconnect all disconnected connectors.</li> <li>• Start engine.</li> <li>• Clear DTC from PCM memory using WDS or equipment.</li> <li>• Race engine a few times.</li> <li>• Does the same DTC appear?</li> </ul>	Yes	Replace PCM, then go to next step.
		No	Go to next step.
10	<b>VERIFY AFTER REPAIR PROCEDURE</b> <ul style="list-style-type: none"> <li>• Perform "After Repair Procedure". (See 01-02A-10 AFTER REPAIR PROCEDURE [ZM].)</li> <li>• Is there any DTC present?</li> </ul>	Yes	Go to applicable DTC inspection. (See 01-02A-15 DTC TABLE [ZM].)
		No	Troubleshooting completed.

### DTC P0125 [ZM]

A3U010201084W45

DTC P0125	Excessive time to enter closed loop fuel control
<b>DETECTION CONDITION</b>	<ul style="list-style-type: none"> <li>• PCM monitors ECT sensor signal at PCM terminal 38 after engine is started engine is cold. If ECT voltage does not reach the expected temperature within specified period, PCM determines that it has taken an excessive amount of time for the engine coolant temperature to reach the temperature necessary to start closed-loop fuel control.</li> </ul> <p><b>Diagnostic support note</b></p> <ul style="list-style-type: none"> <li>• This is a continuous monitor (CCM).</li> <li>• MIL illuminates if PCM detects the above malfunction condition in two consecutive drive cycles.</li> <li>• PENDING CODE is available if PCM detects the above malfunction condition during first drive cycle.</li> <li>• FREEZE FRAME DATA is available.</li> <li>• DTC is stored in PCM memory.</li> </ul>
<b>POSSIBLE CAUSE</b>	<ul style="list-style-type: none"> <li>• ECT sensor malfunction</li> <li>• Poor connection of connectors</li> <li>• PCM malfunction</li> </ul>

## ON-BOARD DIAGNOSTIC [ENGINE CONTROL SYSTEM (ZM)]

### Diagnostic procedure

STEP	INSPECTION	ACTION	
1	<b>VERIFY FREEZE FRAME DATA HAS BEEN RECORDED</b> <ul style="list-style-type: none"> <li>• Has FREEZE FRAME DATA been recorded?</li> </ul>	Yes	Go to next step.
		No	Record FREEZE FRAME DATA on repair order, then go to next step.
2	<b>VERIFY RELATED REPAIR INFORMATION AVAILABILITY</b> <ul style="list-style-type: none"> <li>• Check for related Service Bulletins availability.</li> <li>• Is any related repair information available?</li> </ul>	Yes	Perform repair or diagnosis according to available repair information. <ul style="list-style-type: none"> <li>• If vehicle is not repaired, go to next step.</li> </ul>
		No	Go to next step.
3	<b>VERIFY CURRENT INPUT SIGNAL STATUS-IS CONCERN INTERMITTENT OR CONSTANT</b> <ul style="list-style-type: none"> <li>• Clear DTC using WDS or equivalent.</li> <li>• Start engine.</li> <li>• Warm up engine completely.</li> <li>• Access ECT PID using WDS or equivalent.</li> <li>• Is ECT PID <b>above 35.6 °C {96 °F}</b>?</li> </ul>	Yes	Intermittent concern exists. Go to INTERMITTENT CONCERN TROUBLESHOOTING procedure. (See 01-03A-4 INTERMITTENT CONCERN TROUBLESHOOTING [ZM].)
		No	Go to next step.
4	<b>INSPECT ECT SENSOR CONNECTOR FOR POOR CONNECTION</b> <ul style="list-style-type: none"> <li>• Turn ignition key to OFF.</li> <li>• Disconnect ECT sensor connector.</li> <li>• Check for poor connection (damaged/pulled-out pins, corrosion, etc.).</li> <li>• Is there malfunction?</li> </ul>	Yes	Repair or replace terminal, then go to Step 7.
		No	Go to next step.
5	<b>INSPECT ECT SENSOR</b> <ul style="list-style-type: none"> <li>• Measure resistance between ECT sensor terminals A and B (part-side).</li> <li>• Is resistance <b>approx. 2 kilohms</b>?</li> </ul>	Yes	Go to next step.
		No	Replace ECT sensor, then go to Step 7.
6	<b>INSPECT PCM CONNECTOR FOR POOR CONNECTION</b> <ul style="list-style-type: none"> <li>• Disconnect PCM connector.</li> <li>• Check for poor connection at terminal 38 and 91 (damaged/pulled-out pins, corrosion, etc.).</li> <li>• Is there malfunction?</li> </ul>	Yes	Repair or replace terminal, then go to Step 7.
		No	Go to next step.
7	<b>VERIFY TROUBLESHOOTING OF DTC P0125 COMPLETED</b> <ul style="list-style-type: none"> <li>• Make sure to reconnect all disconnected connectors.</li> <li>• Turn ignition key to ON (Engine OFF).</li> <li>• Clear DTC from PCM memory using WDS or equivalent.</li> <li>• Access ECT PID using WDS or equivalent.</li> <li>• Wait until ECT PID is <b>below 20 °C {68 °F}</b>.</li> <li>• Start engine and warm it up completely.</li> <li>• Is PENDING CODE of same DTC present?</li> </ul>	Yes	Replace PCM, then go to next step.
		No	Go to next step.
8	<b>VERIFY AFTER REPAIR PROCEDURE</b> <ul style="list-style-type: none"> <li>• Perform "After Repair Procedure". (See 01-02A-10 AFTER REPAIR PROCEDURE [ZM].)</li> <li>• Is there any DTC present?</li> </ul>	Yes	Go to applicable DTC inspection. (See 01-02A-15 DTC TABLE [ZM].)
		No	Troubleshooting completed.

01-02A

# ON-BOARD DIAGNOSTIC [ENGINE CONTROL SYSTEM (ZM)]

DTC P0130 [ZM]

A3U010201084W46

DTC P0130	HO2S (Front) circuit malfunction
<b>DETECTION CONDITION</b>	<ul style="list-style-type: none"> <li>• PCM monitors inversion cycle period, lean-to-rich response time and rich-to-lean response time of the sensor. PCM calculates the average of the inversion cycle period-specified inversion cycles, average response time from lean-to-rich, and from rich-to-lean when monitoring conditions are met. If any exceeds threshold, PCM determines that circuit has malfunction.</li> </ul> <p><b>MONITORING CONDITIONS</b></p> <ul style="list-style-type: none"> <li>— Drive mode 3</li> <li>— Following conditions are met:                             <ul style="list-style-type: none"> <li>• Calculation load is <b>20—59%</b> [at engine speed <b>2,000 rpm</b>]</li> <li>• Engine speed is <b>1,410—4,000 rpm</b></li> <li>• Vehicle speed is <b>over 3.77km/h {2.34 mph}</b>.</li> <li>• Engine coolant temperature is <b>above -10°C {14°F}</b>.</li> </ul> </li> </ul> <p><b>Diagnostic support note</b></p> <ul style="list-style-type: none"> <li>• This is an intermittent monitor. (OXYGEN SENSOR)</li> <li>• MIL illuminates if PCM detects either of above malfunction conditions in two consecutive drive cycles.</li> <li>• DIAGNOSTIC MONITORING TEST RESULTS is available.</li> <li>• PENDING CODE is available if PCM detects the above malfunction condition during first drive cycle.</li> <li>• FREEZE FRAME DATA is available.</li> <li>• DTC is stored in PCM memory.</li> </ul>
<b>POSSIBLE CAUSE</b>	<ul style="list-style-type: none"> <li>• Front HO2S deterioration</li> <li>• Front HO2S heater malfunction</li> <li>• PRC solenoid valve malfunction</li> <li>• Pressure regulator malfunction</li> <li>• Fuel pump malfunction</li> <li>• Fuel filter clogged or restricted</li> <li>• Fuel leakage on fuel line from fuel distribution pipe and fuel pump</li> <li>• Fuel return hose clogged</li> <li>• Leakage from exhaust system</li> <li>• Purge solenoid valve malfunction</li> <li>• Purge solenoid hoses improper connection</li> <li>• Insufficient compression</li> <li>• Engine malfunction</li> </ul>

**Diagnostic procedure**

STEP	INSPECTION		ACTION
1	<b>VERIFY FREEZE FRAME DATA HAS BEEN RECORDED</b> <ul style="list-style-type: none"> <li>• Has FREEZE FRAME DATA been recorded?</li> </ul>	Yes	Go to next step.
		No	Record FREEZE FRAME DATA on repair order, then go to next step.
2	<b>VERIFY RELATED REPAIR INFORMATION AVAILABILITY</b> <ul style="list-style-type: none"> <li>• Check for related Service Bulletins availability.</li> <li>• Is any related repair information available?</li> </ul>	Yes	Perform repair or diagnosis according to available repair information. <ul style="list-style-type: none"> <li>• If vehicle is not repaired, go to next step.</li> </ul>
		No	Go to next step.
3	<b>VERIFY RELATED PENDING AND STORED DTCS</b> <ul style="list-style-type: none"> <li>• Turn ignition key to OFF, then start engine.</li> <li>• Verify pending and/or stored DTCs using WDS or equivalent.</li> <li>• Is the following DTC also present?                                     <ul style="list-style-type: none"> <li>— P0442, P0443, P0455, P0031, P0032 or P1450 with P0130</li> </ul> </li> </ul>	Yes	Go to appropriate DTC troubleshooting procedures, then go to Step 15. (See 01-02A-15 DTC TABLE [ZM].)
		No	Go to next step.
4	<b>IDENTIFY TRIGGER DTC FOR FREEZE FRAME DATA</b> <ul style="list-style-type: none"> <li>• Is DTC P0130 on FREEZE FRAME DATA?</li> </ul>	Yes	Go to next step.
		No	Go to troubleshooting procedures for DTC on FREEZE FRAME DATA. (See 01-02A-15 DTC TABLE [ZM].)
5	<b>VERIFY CURRENT INPUT SIGNAL STATUS</b> <ul style="list-style-type: none"> <li>• Warm up engine.</li> <li>• Access O2S11 PID using WDS or equivalent.</li> <li>• Check PID under following accelerator pedal conditions (in PARK).                                     <ul style="list-style-type: none"> <li>— <b>More than 0.55 V</b> when suddenly depressing accelerator pedal (rich condition)</li> <li>— <b>Less than 0.55 V</b> just after release of accelerator pedal (lean condition)</li> </ul> </li> <li>• Is PID reading okay?</li> </ul>	Yes	Go to Step 8.
		No	Go to next step.

## ON-BOARD DIAGNOSTIC [ENGINE CONTROL SYSTEM (ZM)]

STEP	INSPECTION	ACTION	
6	<b>INSPECT INSTALLATION OF FRONT HO2S</b> <ul style="list-style-type: none"> <li>• Check if HO2S (front) is loosely installed.</li> <li>• Is sensor installed securely?</li> </ul>	Yes	Go to next step.
		No	Retighten sensor, then go to Step 15.
7	<b>INSPECT EXHAUST SYSTEM FOR GAS LEAKAGE</b> <ul style="list-style-type: none"> <li>• Visually check if any gas leakage is found between exhaust manifold and HO2S (front).</li> <li>• Is there any gas leakage?</li> </ul>	Yes	Repair or replace any faulty exhaust parts, then go to Step 15.
		No	Replace sensor, then go to Step 15.
8	<b>INSPECT LONG TERM FUEL TRIM</b> <ul style="list-style-type: none"> <li>• Access LONGFT1 PIDs.</li> <li>• Compare it with FREEZE FRAME DATA (FFD) recorded at Step 1.</li> <li>• Is it below FFD value?</li> </ul>	Yes	Engine is driven under rich condition. Go to next step.
		No	Engine is driven under lean condition. Go to Step 11.
9	<b>INSPECT FUEL LINE PRESSURE (Excessive fuel line pressure)</b> <ul style="list-style-type: none"> <li>• Start engine.</li> <li>• Inspect fuel line pressure while engine running. (See 01-14-6 FUEL PRESSURE INSPECTION.)</li> <li>• Is fuel line pressure <b>within 210—250 kPa {2.1—2.6 kgf/cm<sup>2</sup>, 30—36 psi}</b>?</li> </ul>	Yes	Go to Step 14.
		No	Go to next step.
10	<b>VERIFY VACUUM IS LEADING TO PRESSURE REGULATOR</b> <ul style="list-style-type: none"> <li>• Disconnect vacuum hose from pressure regulator.</li> <li>• Verify that vacuum is felt at opening port of disconnected vacuum hose.</li> <li>• Is vacuum felt?</li> </ul>	Yes	Inspect fuel pump maximum pressure and fuel return pipe for clogging. (See 01-14-15 FUEL PUMP UNIT INSPECTION.) <ul style="list-style-type: none"> <li>• If any problem is found, repair or replace suspected parts.</li> <li>• If all items above are okay, replace pressure regulator. Then go to Step 15.</li> </ul>
		No	Verify vacuum hoses are connected correctly. <ul style="list-style-type: none"> <li>• If okay, replace PRC solenoid valve.</li> <li>• If not, reconnect vacuum hoses to correct position. Then go to Step 15.</li> </ul>
11	<b>INSPECT FUEL LINE PRESSURE (Low fuel line pressure)</b> <ul style="list-style-type: none"> <li>• Start engine.</li> <li>• Inspect fuel line pressure while engine running. (See 01-14-6 FUEL PRESSURE INSPECTION.)</li> <li>• Is fuel line pressure <b>within 210—250 kPa {2.1—2.6 kgf/cm<sup>2</sup>, 30—36 psi}</b>?</li> </ul>	Yes	Go to Step 14.
		No	Go to next step.
12	<b>INSPECT FUEL PUMP MAXIMUM PRESSURE</b> <ul style="list-style-type: none"> <li>• Perform fuel pump maximum pressure test. (See 01-14-15 FUEL PUMP UNIT INSPECTION.)</li> <li>• Is fuel pump maximum pressure <b>within 450—630 kPa {4.5—6.5 kgf/cm<sup>2</sup>, 64—92 psi}</b>?</li> </ul>	Yes	Go to next step.
		No	Inspect fuel pump circuit for open or poor connection. <ul style="list-style-type: none"> <li>• Repair or replace suspected circuit.</li> <li>• If circuit is okay, replace fuel pump. Then go to Step 15.</li> </ul>
13	<b>INSPECT FUEL LINE FROM FUEL PUMP TO FUEL DELIVERY PIPE</b> <ul style="list-style-type: none"> <li>• Visually inspect fuel line for any leakage.</li> <li>• Is any fuel leakage found?</li> </ul>	Yes	Replace suspected fuel line, then go to Step 15.
		No	Inspect fuel filters for following: <ul style="list-style-type: none"> <li>• Restriction or clogging at fuel filter (high-pressure)</li> <li>• Foreign material or stain inside fuel filter (low-pressure)</li> </ul> Perform following actions as result. <ul style="list-style-type: none"> <li>• If restriction or clogging is found at fuel filter (high-pressure), replace fuel filter (high-pressure).</li> <li>• If foreign material or stain is found inside fuel filter (low-pressure), clean fuel tank and fuel filter (low-pressure).</li> <li>• If all items above are okay, replace pressure regulator. Then go to Step 15.</li> </ul>

01-02A

## ON-BOARD DIAGNOSTIC [ENGINE CONTROL SYSTEM (ZM)]

STEP	INSPECTION	ACTION	
14	<b>INSPECT SEALING OF ENGINE COOLANT PASSAGE</b>  <b>Warning</b> <ul style="list-style-type: none"> <li>• Removing radiator cap when radiator is hot is dangerous. Scalding coolant and steam may shoot out and cause serious injury.</li> <li>• When removing radiator cap, wrap a thick cloth around and turn it slowly.</li> </ul> <ul style="list-style-type: none"> <li>• Remove radiator cap.</li> <li>• Implement procedure to bleed air from engine coolant, then run engine at idle.</li> <li>• Is there any small bubble, which makes engine coolant white at filling opening?</li> </ul> <b>Note</b> <ul style="list-style-type: none"> <li>• Large bubbles are normal since they are remaining air coming out from engine coolant passage.</li> </ul>	Yes	Air gets in from poor sealing on head gasket or other areas between combustion chamber and engine coolant passage. Repair or replace faulty parts, then go to next step.
		No	Go to next step.
15	<b>VERIFY TROUBLESHOOTING OF DTC P0130 COMPLETED</b> <ul style="list-style-type: none"> <li>• Make sure to reconnect all disconnected connectors.</li> <li>• Turn ignition key to ON (Engine OFF).</li> <li>• Clear DTC from memory using WDS or equivalent.</li> <li>• Start engine.</li> <li>• Run OBD-II DRIVE MODE 1 and 3. (See 01-02A-11 OBD-II DRIVE MODE [ZM].)</li> <li>• Stop vehicle and access ON BOARD SYSTEM READINESS TEST to inspect DRIVE MODE completion status.</li> <li>• Verify RFC changes to YES for OXYGEN SENSOR. — If not, run DRIVE MODE again.</li> <li>• Access DIAGNOSTIC MONITORING TEST RESULTS.</li> <li>• Verify following TEST # values: — 10:01:11, 10:02:11 or 10:03:11</li> <li>• Are they all below MAX value?</li> </ul>	Yes	Replace PCM, then go to next step.
		No	Go to next step.
16	<b>VERIFY AFTER REPAIR PROCEDURE</b> <ul style="list-style-type: none"> <li>• Perform "After Repair Procedure". (See 01-02A-10 AFTER REPAIR PROCEDURE [ZM].)</li> <li>• Is there any DTC present?</li> </ul>	Yes	Go to applicable DTC inspection. (See 01-02A-15 DTC TABLE [ZM].)
		No	Troubleshooting completed.

### DTC P0134 [ZM]

A3U010201084W47

DTC P0134	HO2S (Front) circuit no activity detected
<b>DETECTION CONDITION</b>	<ul style="list-style-type: none"> <li>• PCM monitors input voltage from HO2S (front) when the following monitoring conditions are met. If input voltage from sensor never <b>exceeds 0.55 V</b> for <b>94.4 seconds</b>, PCM determines that sensor circuit is not activated.</li> </ul> <b>MONITORING CONDITIONS</b> <ul style="list-style-type: none"> <li>— Drive mode 3</li> <li>— Following conditions are met: <ul style="list-style-type: none"> <li>• Engine speed is <b>above 1,500 rpm</b>.</li> <li>• Engine coolant temperature is <b>above 80 °C {176 °F}</b>.</li> </ul> </li> </ul> <b>Diagnostic support note</b> <ul style="list-style-type: none"> <li>• This is a continuous monitor (CCM).</li> <li>• MIL illuminates if PCM detects the above malfunction condition in two consecutive drive cycles.</li> <li>• PENDING CODE is available if PCM detects the above malfunction condition during first drive cycle.</li> <li>• FREEZE FRAME DATA is available.</li> <li>• DTC is stored in PCM memory.</li> </ul>



# ON-BOARD DIAGNOSTIC [ENGINE CONTROL SYSTEM (ZM)]

01-02A

<b>DTC P0134</b>	<b>HO2S (Front) circuit no activity detected</b>
<b>POSSIBLE CAUSE</b>	<ul style="list-style-type: none"> <li>HO2S (front) deterioration</li> <li>HO2S (front) heater malfunction</li> <li>Leakage from exhaust system</li> <li>Open or short to ground circuit between HO2S (front) terminal A and PCM terminal 60</li> <li>Insufficient compression</li> <li>Engine malfunction</li> </ul>

### Diagnostic procedure

STEP	INSPECTION	ACTION	
1	<b>VERIFY FREEZE FRAME DATA HAS BEEN RECORDED</b> <ul style="list-style-type: none"> <li>Has FREEZE FRAME DATA been recorded?</li> </ul>	Yes	Go to next step.
		No	Record FREEZE FRAME DATA on repair order, then go to next step.
2	<b>VERIFY RELATED REPAIR INFORMATION AVAILABILITY</b> <ul style="list-style-type: none"> <li>Check for related Service Bulletins availability.</li> <li>Is any related repair information available?</li> </ul>	Yes	Perform repair or diagnosis according to available repair information. <ul style="list-style-type: none"> <li>If vehicle is not repaired, go to next step.</li> </ul>
		No	Go to next step.
3	<b>VERIFY RELATED PENDING AND STORED DTCS</b> <ul style="list-style-type: none"> <li>Turn ignition key to OFF, then start engine.</li> <li>Verify pending and stored DTCs using WDS or equivalent.</li> <li>Is other DTC present except P1170?</li> </ul>	Yes	Go to appropriate DTC troubleshooting procedures.
		No	Go to next step.
4	<b>IDENTIFY TRIGGER DTC FOR FREEZE FRAME DATA</b> <ul style="list-style-type: none"> <li>Is DTC P0134 on FREEZE FRAME DATA?</li> </ul>	Yes	Go to next step.
		No	Go to troubleshooting procedures for DTC on FREEZE FRAME DATA. (See 01-02A-15 DTC TABLE [ZM].)
5	<b>VERIFY CURRENT INPUT SIGNAL STATUS</b> <ul style="list-style-type: none"> <li>Warm up engine.</li> <li>Access O2S11 PID using WDS or equivalent.</li> <li>Check PID under following accelerator pedal condition (in PARK).                             <ul style="list-style-type: none"> <li>— <b>More than 0.55 V</b> when suddenly depressing accelerator pedal (rich condition).</li> <li>— <b>Less than 0.55 V</b> just after release of accelerator pedal (lean condition)</li> </ul> </li> <li>Is PID reading okay?</li> </ul>	Yes	Go to Step 8.
		No	Go to next step.

## ON-BOARD DIAGNOSTIC [ENGINE CONTROL SYSTEM (ZM)]

STEP	INSPECTION	ACTION	
6	<b>INSPECT INSTALLATION OF HO2S</b> <ul style="list-style-type: none"> <li>• Check if HO2S (front) is loosely installed.</li> <li>• Is sensor installed securely?</li> </ul>	Yes	Go to next step.
		No	Install sensor securely, then go to Step 10.
7	<b>INSPECT EXHAUST SYSTEM FOR GAS LEAKAGE</b> <ul style="list-style-type: none"> <li>• Visually check if any gas leakage is found between exhaust manifold and HO2S (front).</li> <li>• Is there any gas leakage?</li> </ul>	Yes	Repair or replace any faulty exhaust parts, then go to Step 10.
		No	<ul style="list-style-type: none"> <li>• Inspect the following harnesses for open or short to ground circuit. Repair or replace harness if necessary.                             <ul style="list-style-type: none"> <li>— HO2S (front) terminal A (harness-side) to PCM terminal 60 (harness-side)                                     <ul style="list-style-type: none"> <li>• Repair or replace harness if necessary.</li> </ul> </li> </ul> </li> <li>• If all items above are okay, replace faulty sensor. Then go to Step 10.</li> </ul>
8	<b>INSPECT SEALING OF ENGINE COOLANT PASSAGE</b> <p><b>Warning</b></p> <ul style="list-style-type: none"> <li>• <b>Removing radiator cap when radiator is hot is dangerous. Scalding coolant and steam may shoot out and cause serious injury.</b></li> <li>• <b>When removing radiator cap, wrap a thick cloth around and turn it slowly.</b></li> </ul> <ul style="list-style-type: none"> <li>• Remove radiator cap.</li> <li>• Implement procedure to bleed air from engine coolant, then run engine at idle.</li> <li>• Is there any small bubble which makes engine coolant white at filling opening?</li> </ul> <p><b>Note</b></p> <ul style="list-style-type: none"> <li>• Large bubbles are normal since they are remaining air coming out from engine coolant passage.</li> </ul>	Yes	Air gets in from poor sealing on head gasket or other areas between combustion chamber and engine coolant passage. Repair or replace faulty parts, then go to Step 10.
		No	Go to next step.
9	<b>INSPECT ENGINE COMPRESSION</b> <ul style="list-style-type: none"> <li>• Inspect engine compression. (See 01-10A-8 COMPRESSION INSPECTION [ZM].)</li> <li>• Is it okay?</li> </ul>	Yes	Go to next step.
		No	Implement engine overhaul for repairs, then go to next step.
10	<b>VERIFY TROUBLESHOOTING OF DTC P0134 COMPLETED</b> <ul style="list-style-type: none"> <li>• Make sure to reconnect all disconnected connectors.</li> <li>• Turn ignition key to ON (Engine OFF).</li> <li>• Clear DTC from memory using WDS or equivalent.</li> <li>• Start engine.</li> <li>• Access RPM and ECT PIDs using WDS or equivalent.</li> <li>• Verify that ECT PID is reading <b>above 80 °C {176 °F}</b>.</li> <li>• Increase engine speed <b>above 1,500 rpm</b> (RPM PID reading) for <b>more than 94.4 seconds</b>.</li> <li>• Is PENDING CODE of same DTC present?</li> </ul>	Yes	Replace PCM, then go to next step.
		No	Go to next step.
11	<b>VERIFY AFTER REPAIR PROCEDURE</b> <ul style="list-style-type: none"> <li>• Perform "After Repair Procedure". (See 01-02A-10 AFTER REPAIR PROCEDURE [ZM].)</li> <li>• Is there any DTC present?</li> </ul>	Yes	Go to applicable DTC inspection. (See 01-02A-15 DTC TABLE [ZM].)
		No	Troubleshooting completed.

# ON-BOARD DIAGNOSTIC [ENGINE CONTROL SYSTEM (ZM)]

DTC P0138 [ZM]

A3U010201084W48

01-02A

<b>DTC P0138</b>	<b>HO2S (rear) circuit high input</b>
<b>DETECTION CONDITION</b>	<ul style="list-style-type: none"> <li>PCM monitors input voltage from HO2S (rear). If input voltage from sensor is <b>above 0.45 V for 6 seconds</b> during deceleration fuel cut, PCM determines that the circuit input is high.</li> </ul> <p><b>Diagnostic support note</b></p> <ul style="list-style-type: none"> <li>This is a continuous monitor (CCM).</li> <li>MIL illuminates if PCM detects the above malfunction condition in two consecutive drive cycles.</li> <li>PENDING CODE is available if PCM detects the above malfunction condition during first drive cycle.</li> <li>FREEZE FRAME DATA is available.</li> <li>DTC is stored in PCM memory.</li> </ul>
<b>POSSIBLE CAUSE</b>	<ul style="list-style-type: none"> <li>HO2S (rear) malfunction</li> <li>Short to power circuit in wiring between HO2S (rear) terminal A and PCM terminal 35</li> </ul>

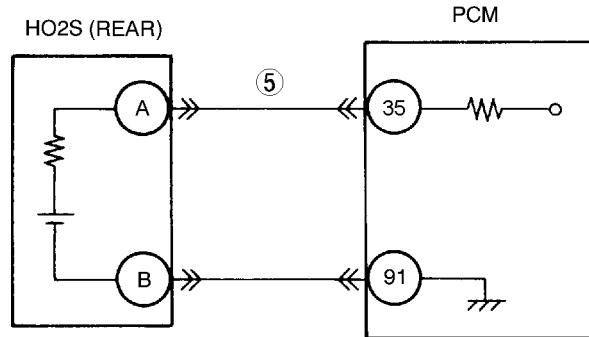

HO2S (REAR)

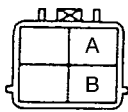

VEHICLE HARNESS SIDE CONNECTOR  
(VIEW FROM TERMINAL SIDE)

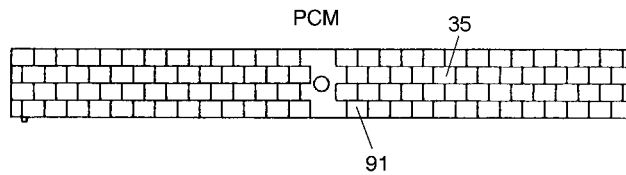

HARNESS SIDE CONNECTOR  
(VIEW FROM HARNESS SIDE)

**Diagnostic procedure**

STEP	INSPECTION		ACTION
1	<b>VERIFY FREEZE FRAME DATA HAS BEEN RECORDED</b> <ul style="list-style-type: none"> <li>Has FREEZE FRAME DATA been recorded?</li> </ul>	Yes	Go to next step.
		No	Record FREEZE FRAME DATA on repair order, then go to next step.
2	<b>VERIFY RELATED REPAIR INFORMATION AVAILABILITY</b> <ul style="list-style-type: none"> <li>Check for related Service Bulletins availability.</li> <li>Is any related repair information available?</li> </ul>	Yes	Perform repair or diagnosis according to available repair information. <ul style="list-style-type: none"> <li>If vehicle is not repaired, go to next step.</li> </ul>
		No	Go to next step.
3	<b>VERIFY RELATED PENDING OR STORED DTCS</b> <ul style="list-style-type: none"> <li>Turn ignition key to OFF, then Start engine.</li> <li>Verify pending codes or stored DTCs using WDS or equivalent.</li> <li>Is other DTC present?</li> </ul>	Yes	Go to appropriate DTC troubleshooting procedures. (See 01-02A-15 DTC TABLE [ZM].)
		No	Go to next step.
4	<b>IDENTIFY TRIGGER DTC FOR FREEZE FRAME DATA</b> <ul style="list-style-type: none"> <li>Is DTC P0138 on FREEZE FRAME DATA?</li> </ul>	Yes	Go to next step.
		No	Go to troubleshooting procedures for DTC on FREEZE FRAME DATA. (See 01-02A-15 DTC TABLE [ZM].)

## ON-BOARD DIAGNOSTIC [ENGINE CONTROL SYSTEM (ZM)]

STEP	INSPECTION	ACTION	
5	<b>INSPECT HO2S (REAR) SIGNAL CIRCUIT FOR SHORT TO POWER SUPPLY CIRCUIT</b> <ul style="list-style-type: none"> <li>• Turn ignition key to OFF.</li> <li>• Disconnect HO2S (rear) connector.</li> <li>• Turn ignition key to ON (Engine OFF).</li> <li>• Measure voltage between HO2S (rear) terminal A (harness-side) and body ground.</li> <li>• Is any voltage reading?</li> </ul>	Yes	Replace short to power supply circuit, then go to Step 7.
		No	Go to next step.
6	<b>VERIFY CURRENT INPUT SIGNAL STATUS</b> <ul style="list-style-type: none"> <li>• Start engine.</li> <li>• Access O2S12 PID using WDS or equivalent.</li> <li>• Verify PID while racing engine at least <b>10 times</b> (in neutral position).</li> <li>• Does PID reading stay <b>above 0.45 V</b>?</li> </ul>	Yes	Replace HO2S (rear), then go to next step.
		No	Go to next step.
7	<b>VERIFY TROUBLESHOOTING OF DTC P0138 COMPLETED</b> <ul style="list-style-type: none"> <li>• Make sure to reconnect all disconnected connectors.</li> <li>• Turn ignition key to ON (Engine OFF).</li> <li>• Clear DTC from memory using WDS or equivalent.</li> <li>• Run OBD-II DRIVE MODE 1 and 3.</li> <li>• Is PENDING CODE of same DTC present?</li> </ul>	Yes	Replace PCM, then go to next step.
		No	Go to next step.
8	<b>VERIFY AFTER REPAIR PROCEDURE</b> <ul style="list-style-type: none"> <li>• Perform "After Repair Procedure". (See 01-02A-10 AFTER REPAIR PROCEDURE [ZM].)</li> <li>• Is there any DTC present?</li> </ul>	Yes	Go to applicable DTC inspection. (See 01-02A-15 DTC TABLE [ZM].)
		No	Troubleshooting completed.

# ON-BOARD DIAGNOSTIC [ENGINE CONTROL SYSTEM (ZM)]

DTC P0140 [ZM]

A3U010201084W49

01-02A

<b>DTC P0140</b>	<b>HO2S (rear) circuit no activity detected</b>
<b>DETECTION CONDITION</b>	<ul style="list-style-type: none"> <li>PCM monitors input voltage from HO2S (rear) when the following monitoring conditions are met. If input voltage from sensor never <b>exceeds 0.55 V</b> for <b>30 seconds</b>, PCM determines that sensor circuit is not activated.</li> </ul> <p><b>MONITORING CONDITIONS</b></p> <ul style="list-style-type: none"> <li>— Drive mode 3</li> <li>— Following conditions are met:             <ul style="list-style-type: none"> <li>• Engine speed is <b>above 1,500 rpm</b>.</li> <li>• Engine coolant temperature is <b>above 80 °C {176 °F}</b>.</li> </ul> </li> </ul> <p><b>Diagnostic support note</b></p> <ul style="list-style-type: none"> <li>• This is a continuous monitor (CCM).</li> <li>• MIL illuminates if PCM detects the above malfunction condition in two consecutive drive cycles.</li> <li>• PENDING CODE is available if PCM detects the above malfunction condition during first drive cycle.</li> <li>• FREEZE FRAME DATA is available.</li> <li>• DTC is stored in PCM memory.</li> </ul>
<b>POSSIBLE CAUSE</b>	<ul style="list-style-type: none"> <li>• HO2S (rear) deterioration</li> <li>• HO2S (rear) heater malfunction</li> <li>• Leakage from exhaust system</li> <li>• Open or short to ground circuit between HO2S (rear) terminal A and PCM terminal 35</li> <li>• Insufficient compression</li> <li>• Engine malfunction</li> </ul>

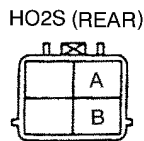
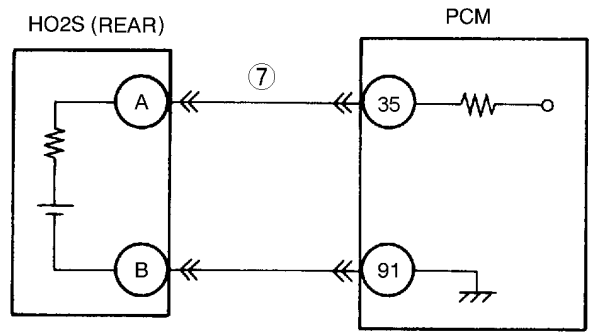

VEHICLE HARNESS SIDE CONNECTOR  
(VIEW FROM TERMINAL SIDE)

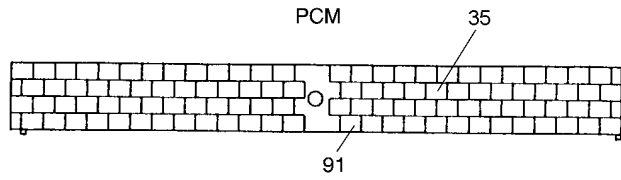

HARNESS SIDE CONNECTOR  
(VIEW FROM HARNESS SIDE)

**Diagnostic procedure**

STEP	INSPECTION	ACTION	
1	<b>VERIFY FREEZE FRAME DATA HAS BEEN RECORDED</b> <ul style="list-style-type: none"> <li>• Has FREEZE FRAME DATA been recorded?</li> </ul>	Yes	Go to next step.
		No	Record FREEZE FRAME DATA on repair order, then go to next step.
2	<b>VERIFY RELATED REPAIR INFORMATION AVAILABILITY</b> <ul style="list-style-type: none"> <li>• Check for related Service Bulletins availability.</li> <li>• Is any related repair information available?</li> </ul>	Yes	Perform repair or diagnosis according to available repair information. <ul style="list-style-type: none"> <li>• If vehicle is not repaired, go to next step.</li> </ul>
		No	Go to next step.
3	<b>VERIFY RELATED PENDING AND STORED DTCS</b> <ul style="list-style-type: none"> <li>• Turn ignition key to OFF, then start engine.</li> <li>• Verify pending and stored DTCs using WDS or equivalent.</li> <li>• Is other DTC present except P1170?</li> </ul>	Yes	Go to appropriate DTC troubleshooting procedures. (See 01-02A-15 DTC TABLE [ZM].)
		No	Go to next step.

## ON-BOARD DIAGNOSTIC [ENGINE CONTROL SYSTEM (ZM)]

STEP	INSPECTION	ACTION	
4	<b>IDENTIFY TRIGGER DTC FOR FREEZE FRAME DATA</b> <ul style="list-style-type: none"> <li>Is DTC P0140 on FREEZE FRAME DATA?</li> </ul>	Yes	Go to next step.
		No	Go to troubleshooting procedures for DTC on FREEZE FRAME DATA. (See 01–02A–15 DTC TABLE [ZM].)
5	<b>VERIFY CURRENT INPUT SIGNAL STATUS</b> <ul style="list-style-type: none"> <li>Warm up engine.</li> <li>Access O2S12 PID using WDS or equivalent.</li> <li>Verify PID while racing engine at least <b>10 times</b> (in neutral position).</li> <li>Is PID reading okay?                             <ul style="list-style-type: none"> <li>— <b>More than 0.55 V</b> at least once during engine racing.</li> </ul> </li> </ul>	Yes	Go to Step 8.
		No	Go to next step.
6	<b>INSPECT INSTALLATION OF HO2S (REAR)</b> <ul style="list-style-type: none"> <li>Check if HO2S (rear) is loosely installed.</li> <li>Is sensor installed securely?</li> </ul>	Yes	Go to next step.
		No	Install sensor securely, then go to Step 10.
7	<b>INSPECT EXHAUST SYSTEM FOR GAS LEAKAGE</b> <ul style="list-style-type: none"> <li>Visually check if any gas leakage is found between exhaust pipe and HO2S (rear).</li> <li>Is there any gas leakage?</li> </ul>	Yes	Repair or replace any faulty exhaust parts, then go to Step 10.
		No	<ul style="list-style-type: none"> <li>Inspect for open or short to ground circuit between HO2S (rear) terminal A (harness-side) and PCM terminal 35 (harness-side).                             <ul style="list-style-type: none"> <li>— Repair or replace harness if necessary.</li> </ul> </li> <li>If all items above are okay, replace HO2S (rear). Then go to Step 10.</li> </ul>
8	<b>INSPECT SEALING OF ENGINE COOLANT PASSAGE</b> <p><b>Warning</b></p> <ul style="list-style-type: none"> <li><b>Removing radiator cap when radiator is hot is dangerous. Scalding coolant and steam may shoot out and cause serious injury.</b></li> <li><b>When removing radiator cap, wrap a thick cloth around and turn it slowly.</b></li> </ul> <ul style="list-style-type: none"> <li>Remove radiator cap.</li> <li>Implement procedure to bleed air from engine coolant, then run engine at idle.</li> <li>Is there any small bubble which makes engine coolant white at filling opening?</li> </ul> <p><b>Note</b></p> <ul style="list-style-type: none"> <li>Large bubbles are normal since they are remaining air coming out from engine coolant passage.</li> </ul>	Yes	Air gets in from poor sealing on head gasket or other areas between combustion chamber and engine coolant passage. Repair or replace faulty parts, then go to Step 10.
		No	Go to next step.
9	<b>INSPECT ENGINE COMPRESSION</b> <ul style="list-style-type: none"> <li>Inspect engine compression. (See 01–10A–8 COMPRESSION INSPECTION [ZM].)</li> <li>Is it okay?</li> </ul>	Yes	Go to next step.
		No	Implement engine overhaul for repairs, then go to next step.
10	<b>VERIFY TROUBLESHOOTING OF DTC P0140 COMPLETED</b> <ul style="list-style-type: none"> <li>Make sure to reconnect all disconnected connectors.</li> <li>Turn ignition key to ON (Engine OFF).</li> <li>Clear DTC from memory using WDS or equivalent.</li> <li>Access RPM and ECT PIDs using WDS or equivalent.</li> <li>Verify that ECT PID is reading <b>above 80 °C {176 °F}</b>.</li> <li>Increase engine speed <b>above 1,500 rpm</b> (RPM PID reading) for <b>more than 30 seconds</b>.</li> <li>Is PENDING CODE of same DTC present?</li> </ul>	Yes	Replace PCM, then go to next step.
		No	Go to next step.

## ON-BOARD DIAGNOSTIC [ENGINE CONTROL SYSTEM (ZM)]

STEP	INSPECTION	ACTION
11	<b>VERIFY AFTER REPAIR PROCEDURE</b> <ul style="list-style-type: none"> <li>Perform "After Repair Procedure". (See 01-02A-10 AFTER REPAIR PROCEDURE [ZM].)</li> <li>Is there any DTC present?</li> </ul>	Yes Go to applicable DTC inspection. (See 01-02A-15 DTC TABLE [ZM].)
		No Troubleshooting completed.

### DTC P0171 [ZM]

A3U010201084W50

01-02A

DTC P0171	Fuel trim system too lean
<b>DETECTION CONDITION</b>	<ul style="list-style-type: none"> <li>PCM monitors short term fuel trim (SHRTFT) and long term fuel trim (LONGFT) values when DRIVE MODE 1 is run. If fuel trim exceeds preprogrammed criteria, PCM determines that the fuel system is too lean.</li> </ul> <p><b>Diagnostic support note</b></p> <ul style="list-style-type: none"> <li>This is a continuous monitor. (FUEL SYSTEM)</li> <li>MIL illuminates if PCM detects the above malfunction conditions in two consecutive drive cycles.</li> <li>PENDING CODE is available if PCM detects the above malfunction conditions during first drive cycle.</li> <li>FREEZE FRAME DATA is available.</li> <li>DTC is stored in PCM memory.</li> </ul>
<b>POSSIBLE CAUSE</b>	<ul style="list-style-type: none"> <li>Misfire</li> <li>HO2S (front) deterioration</li> <li>HO2S (front) heater malfunction</li> <li>PRC solenoid valve malfunction</li> <li>Pressure regulator malfunction</li> <li>Fuel pump malfunction</li> <li>Fuel filter clogged or restricted</li> <li>Fuel leakage on fuel line from fuel delivery pipe and fuel pump</li> <li>Fuel return hose clogged</li> <li>Leakage from exhaust system</li> <li>Purge solenoid valve malfunction</li> <li>Purge solenoid hoses improper connection</li> <li>Insufficient compression</li> </ul>

### Diagnostic procedure

STEP	INSPECTION	ACTION
1	<b>VERIFY FREEZE FRAME DATA HAS BEEN RECORDED</b> <ul style="list-style-type: none"> <li>Has FREEZE FRAME DATA been recorded?</li> </ul>	Yes Go to next step.
		No Record FREEZE FRAME DATA on repair order, then go to next step.
2	<b>VERIFY RELATED REPAIR INFORMATION AVAILABILITY</b> <ul style="list-style-type: none"> <li>Check for related Service Bulletins availability.</li> <li>Is any related repair information available?</li> </ul>	Yes Perform repair or diagnosis according to available repair information. <ul style="list-style-type: none"> <li>If vehicle is not repaired, go to next step.</li> </ul>
		No Go to next step.
3	<b>VERIFY RELATED PENDING CODE OR STORED DTCs</b> <ul style="list-style-type: none"> <li>Turn ignition key to OFF, then start engine.</li> <li>Verify related PENDING CODE or stored DTCs.</li> <li>Are other DTCs present?</li> </ul>	Yes If misfire DTC is present, go to Step 8. If other DTC is present, go to appropriate DTC troubleshooting procedures. (See 01-02A-15 DTC TABLE [ZM].)
		No If drivability concern is present, go to Step 8. If not, go to next step.
4	<b>IDENTIFY TRIGGER DTC FOR FREEZE FRAME DATA</b> <ul style="list-style-type: none"> <li>Is DTC P0171 on FREEZE FRAME DATA?</li> </ul>	Yes Go to next step.
		No Go to troubleshooting procedures for DTC on FREEZE FRAME DATA.
5	<b>VERIFY CURRENT INPUT SIGNAL STATUS (IGNITION KEY TO ON/IDLE)</b> <ul style="list-style-type: none"> <li>Access ECT, MAF, TP and VS PIDs using WDS or equivalent. (See 01-40A-8 PID/DATA MONITOR table (Reference).)</li> <li>Is there any signal that is far out of specification when ignition key is ON and engine runs?</li> </ul>	Yes Inspect suspected sensor and excessive resistance in related wiring harnesses. Repair or replace if necessary. Then go to Step 20.
		No Go to next step.

## ON-BOARD DIAGNOSTIC [ENGINE CONTROL SYSTEM (ZM)]

STEP	INSPECTION	ACTION
6	<b>VERIFY CURRENT INPUT SIGNAL STATUS UNDER TROUBLE CONDITION</b> <ul style="list-style-type: none"> <li>Inspect same PIDs as Step 5 while simulating FREEZE FRAME DATA condition.</li> <li>Is there any input signal which causes drastic changes?</li> </ul>	Yes Inspect suspected sensor and related wiring harnesses, and repair or replace it. Then go to Step 20.
		No Go to next step.
7	<b>VERIFY CURRENT INPUT SIGNAL STATUS OF HO2S FRONT</b> <ul style="list-style-type: none"> <li>Access O2S11 PID using WDS or equivalent.</li> <li>Check PID under following accelerator pedal condition. (in PARK)                             <ul style="list-style-type: none"> <li>— <b>More than 0.45 V</b> when suddenly depressing accelerator pedal (rich condition)</li> <li>— <b>Less than 0.45 V</b> just after release of accelerator pedal (lean condition)</li> </ul> </li> <li>Is PID reading okay?</li> </ul>	Yes Inspect following for air suction due to cracks, damages and loose parts: <ul style="list-style-type: none"> <li>From air cleaner to throttle body</li> <li>From throttle body to dynamic chamber</li> <li>From dynamic chamber to intake manifold</li> <li>Vacuum hoses</li> </ul> <p style="text-align: center;"><b>Note</b></p> <ul style="list-style-type: none"> <li>Engine speed may change when rust penetrating agent is sprayed on the air suction area.</li> </ul> Repair or replace any faulty part, then go to Step 20.
		No Visually inspect for any gas leakage between exhaust manifold and HO2S (front). <ul style="list-style-type: none"> <li>If there is no leakage, replace HO2S (front).</li> </ul> Then go to Step 20.
8	<b>INSPECT MAF SIGNAL</b> <ul style="list-style-type: none"> <li>Start engine.</li> <li>Access MAF PID using WDS or equivalent.</li> <li>Verify that MAF PID changes quickly according to race engine RPM.</li> <li>Is MAF PID response okay?</li> </ul>	Yes Go to next step.
		No Replace MAF sensor, then go to Step 20.
9	<b>INSPECT FOR EXCESSIVE AIR SUCTION OF INTAKE-AIR SYSTEM</b> <ul style="list-style-type: none"> <li>Visually inspect for loose, cracked or damaged hoses on intake-air system.</li> <li>Is there malfunction?</li> </ul>	Yes Repair or replace source of air suction, then go to Step 20.
		No Go to next step.
10	<b>INSPECT FUEL LINE PRESSURE</b> <ul style="list-style-type: none"> <li>Turn ignition key to OFF.</li> </ul> <p style="text-align: center;"><b>Note</b></p> <ul style="list-style-type: none"> <li>If engine will not start, inspect fuel line pressure with ignition key ON.</li> </ul> <ul style="list-style-type: none"> <li>Inspect fuel line pressure while engine running. (See 01-14-6 FUEL PRESSURE INSPECTION.)</li> <li>Is fuel line pressure <b>within 210—250 kPa {2.1—2.6 kgf/cm<sup>2</sup>, 30—36 psi}</b>?</li> </ul>	Yes Go to Step 14.
		No If fuel line pressure is too high: Go to next step. If fuel line pressure is too low: Go to Step 12.
11	<b>VERIFY VACUUM IS LEADING TO PRESSURE REGULATOR</b> <ul style="list-style-type: none"> <li>Disconnect vacuum hose from pressure regulator.</li> <li>Verify that vacuum is felt at opening port of disconnected vacuum hose.</li> <li>Is vacuum felt?</li> </ul>	Yes Inspect fuel pump maximum pressure and fuel return hose for clogging. <ul style="list-style-type: none"> <li>If any problem is found, repair or replace suspected parts.</li> <li>If all items above are okay, replace pressure regulator.</li> </ul> Then go to Step 20.
		No Verify vacuum hoses are connected correctly. <ul style="list-style-type: none"> <li>If okay, replace PRC solenoid valve, then go to Step 20.</li> <li>If not, reconnect vacuum hoses to correct position, then go to Step 20.</li> </ul>
12	<b>INSPECT FUEL PUMP MAXIMUM PRESSURE</b> <ul style="list-style-type: none"> <li>Perform fuel pump maximum pressure test. (See 01-14-15 FUEL PUMP UNIT INSPECTION.)</li> <li>Is fuel pump maximum pressure <b>within 450—630 kPa {4.5—6.5 kgf/cm<sup>2</sup>, 64—92 psi}</b>?</li> </ul>	Yes Go to next step.
		No Inspect fuel pump circuit for open or poor connection. Repair or replace suspected circuit, then go to Step 20. <ul style="list-style-type: none"> <li>If circuit is okay, replace fuel pump. Then go to Step 20.</li> </ul>



## ON-BOARD DIAGNOSTIC [ENGINE CONTROL SYSTEM (ZM)]

STEP	INSPECTION	ACTION	
13	<b>INSPECT FUEL LINE FROM FUEL PUMP TO FUEL DELIVERY PIPE</b> <ul style="list-style-type: none"> <li>• Visually inspect fuel line for any leakage.</li> <li>• Is any fuel leakage found?</li> </ul>	Yes	Replace suspected fuel line, then go to Step 20.
		No	Inspect fuel filters for following: <ul style="list-style-type: none"> <li>• Restriction or clogging at fuel filter (high-pressure).</li> <li>• Foreign materials or stain inside fuel filter (low-pressure)</li> </ul> Perform following actions as result. <ul style="list-style-type: none"> <li>• If restriction or clogging is found at fuel filter (high-pressure), replace fuel filter (high-pressure).</li> <li>• If foreign materials or stain is found inside fuel filter (low-pressure), clean of fuel tank and fuel filter (low-pressure).</li> <li>• If all items above are okay, replace pressure regulator. Then go to Step 20.</li> </ul>
14	<b>CHECK IGNITION COIL OPERATION AND HIGH-TENSION LEAD WITH TIMING LIGHT</b> <ul style="list-style-type: none"> <li>• Verify blinking condition on each cylinders using timing light at idle.</li> <li>• Do all cylinders show blinking condition?</li> </ul>	Yes	Go to Step 18.
		No	Go to next step.
15	<b>CHECK HIGH-TENSION LEADS OF NON-BLINKING CYLINDER</b> <ul style="list-style-type: none"> <li>• Turn ignition key to OFF.</li> <li>• Inspect high-tension leads for installation condition, corrosion on terminal, open lead and damaged cover.</li> <li>• Is condition of high-tension lead okay?</li> </ul>	Yes	Go to next step.
		No	Replace faulty high-tension lead, then go to Step 20.
16	<b>INSPECT POWER SUPPLY TERMINAL AT IGNITION COIL CONNECTOR</b> <ul style="list-style-type: none"> <li>• Disconnect ignition coil connector.</li> <li>• Turn ignition key to ON (Engine OFF).</li> <li>• Check voltage at ignition coil connector terminal D (harness-side) and body ground.</li> <li>• Is voltage reading <b>B+</b>?</li> </ul>	Yes	Go to next step.
		No	Check for open circuit between ignition coil connector and ignition switch. Repair or replace wiring harness, then go to Step 20.
17	<b>INSPECT IGNITION COIL RESISTANCE</b> <ul style="list-style-type: none"> <li>• Check ignition coil resistance. (See 01-18-2 IGNITION COIL INSPECTION.)</li> <li>• Is coil resistance okay?</li> </ul>	Yes	Go to next step.
		No	Replace ignition coil, then go to Step 20.
18	<b>INSPECT ENGINE COMPRESSION</b> <ul style="list-style-type: none"> <li>• Inspect engine compression. (See 01-10A-8 COMPRESSION INSPECTION [ZM].)</li> <li>• Is it okay?</li> </ul>	Yes	Go to next step.
		No	Implement engine overhaul for repairs, then go to Step 20.
19	<b>INSPECT FUEL INJECTOR OPERATION</b> <ul style="list-style-type: none"> <li>• Remove fuel injector from suspected bank. (See 01-14-24 FUEL INJECTOR INSPECTION.)</li> <li>• Inspect injector operation.</li> <li>• Is fuel injector okay?</li> </ul>	Yes	Go to next step.
		No	Replace injector, then go to Step 20.
20	<b>VERIFY TROUBLESHOOTING OF DTC P0171 COMPLETED</b> <ul style="list-style-type: none"> <li>• Make sure to reconnect all disconnected connectors.</li> <li>• Clear DTC from memory using WDS or equivalent.</li> <li>• Run OBD-II DRIVE MODE 1, 2 and 3.</li> <li>• Is PENDING CODE P0171 present?</li> </ul>	Yes	Replace PCM, then go to next step.
		No	Go to next step.
21	<b>VERIFY AFTER REPAIR PROCEDURE</b> <ul style="list-style-type: none"> <li>• Perform "After Repair Procedure". (See 01-02A-10 AFTER REPAIR PROCEDURE [ZM].)</li> <li>• Is there any DTC present?</li> </ul>	Yes	Go to applicable DTC inspection. (See 01-02A-15 DTC TABLE [ZM].)
		No	Troubleshooting completed.

01-02A

# ON-BOARD DIAGNOSTIC [ENGINE CONTROL SYSTEM (ZM)]

DTC P0172 [ZM]

A3U010201084W51

<b>DTC P0172</b>	<b>Fuel trim system (RH) too rich</b>
<b>DETECTION CONDITION</b>	<ul style="list-style-type: none"> <li>• PCM monitors short term fuel trim (SHRTFT) and long term fuel trim (LONGFT) values when DRIVE MODE 1 is run. If fuel trim exceeds pre programmed criteria, PCM determines that the fuel system is too rich.</li> </ul> <p><b>Diagnostic support note</b></p> <ul style="list-style-type: none"> <li>• This is a continuous monitor. (FUEL SYSTEM)</li> <li>• MIL illuminates if PCM detects the above malfunction conditions in two consecutive drive cycles.</li> <li>• PENDING CODE is available if PCM detects the above malfunction condition during first drive cycle.</li> <li>• FREEZE FRAME DATA is available.</li> <li>• DTC is stored in PCM memory.</li> </ul>
<b>POSSIBLE CAUSE</b>	<ul style="list-style-type: none"> <li>• Misfire</li> <li>• HO2S (front) deterioration</li> <li>• HO2S heater (front) malfunction</li> <li>• PRC solenoid valve malfunction</li> <li>• Pressure regulator malfunction</li> <li>• Fuel pump malfunction</li> <li>• Fuel return hose clogged</li> <li>• Purge solenoid valve malfunction</li> <li>• Purge solenoid hoses improper connection</li> <li>• PCV valve malfunction</li> </ul>

**Diagnostic procedure**

STEP	INSPECTION	ACTION
1	<b>VERIFY FREEZE FRAME DATA HAS BEEN RECORDED</b> • Has FREEZE FRAME DATA been recorded?	Yes Go to next step.
		No Record FREEZE FRAME DATA on repair order, then go to next step.
2	<b>VERIFY RELATED REPAIR INFORMATION AVAILABILITY</b> • Check for related Service Bulletins availability. • Is any related repair information available?	Yes Perform repair or diagnosis according to available repair information. • If vehicle is not repaired, go to next step.
		No Go to next step.
3	<b>VERIFY RELATED PENDING CODE OR STORED DTCS</b> • Turn ignition key to OFF, then start engine. • Verify related pending code or stored DTCs. • Are other DTCs present?	Yes Go to appropriate DTC troubleshooting procedures.
		No If drivability concern or rough idle is present, go to Step 10. If not, go to next step.
4	<b>IDENTIFY TRIGGER DTC FOR FREEZE FRAME DATA</b> • Is DTC P0172 on FREEZE FRAME DATA?	Yes Go to next step.
		No Go to troubleshooting procedures for DTC on FREEZE FRAME DATA.
5	<b>VERIFY CURRENT INPUT SIGNAL STATUS (IGNITION KEY TO ON/IDLE)</b> • Access ECT, MAF, TP and VS PIDs using WDS or equivalent. (See 01-40A-8 PID/DATA MONITOR table (Reference).) • Is there any signal that is far out of specification when ignition key is ON and engine runs?	Yes Inspect suspected sensor and excessive resistance in related wiring harnesses. Repair or replace if necessary. Then go to Step 12.
		No Go to next step.
6	<b>VERIFY CURRENT INPUT SIGNAL STATUS UNDER TROUBLE CONDITION</b> • Inspect same PIDs as in Step 5 while simulating FREEZE FRAME DATA condition. • Is there any input signal which causes drastic changes?	Yes Inspect suspected sensor and related wiring harnesses, and repair or replace it. Then go to Step 12.
		No Go to next step.
7	<b>VERIFY CURRENT INPUT SIGNAL STATUS OF HO2S (FRONT)</b> • Access O2S11 PID using WDS or equivalent. • Check PID under following accelerator pedal condition (in PARK or NEUTRAL). — <b>More than 0.45 V</b> when suddenly depressing accelerator pedal (rich condition) — <b>Less than 0.45 V</b> just after release of accelerator pedal (lean condition) • Is PID reading okay?	Yes Go to next step.
		No Replace suspected HO2S (front). Then go to Step 12.

## ON-BOARD DIAGNOSTIC [ENGINE CONTROL SYSTEM (ZM)]

STEP	INSPECTION	ACTION	
8	<b>INSPECT FUEL LINE PRESSURE</b> <ul style="list-style-type: none"> <li>• Turn ignition key to OFF.</li> <li>• Inspect fuel line pressure while engine running. (See 01–14–6 FUEL PRESSURE INSPECTION.)</li> <li>• Is fuel line pressure <b>within 210—250 kPa {2.1—2.6 kgf/cm<sup>2</sup>, 30—36 psi}</b>?</li> </ul>	Yes	Go to Step 10.
		No	Go to next step.
9	<b>VERIFY VACUUM IS LEADING TO PRESSURE REGULATOR</b> <ul style="list-style-type: none"> <li>• Start engine.</li> <li>• Disconnect vacuum hose from pressure regulator.</li> <li>• Verify that the vacuum is felt at opening port of disconnected vacuum hose.</li> <li>• Is vacuum felt?</li> </ul>	Yes	Inspect fuel pump maximum pressure and fuel return hose for clogging. <ul style="list-style-type: none"> <li>• If any problem found, repair or replace suspected parts.</li> <li>• If all items above are okay, replace pressure regulator. Then go to Step 12.</li> </ul>
		No	Verify vacuum hoses are connected correctly. <ul style="list-style-type: none"> <li>• If okay, replace PRC solenoid valve, then go to Step 12.</li> <li>• If not, reconnect vacuum hoses to correct position, then go to Step 12.</li> </ul>
10	<b>INSPECT PURGE SOLENOID VALVE FOR WHETHER STUCK OPEN</b> <ul style="list-style-type: none"> <li>• Turn ignition key to OFF.</li> <li>• Disconnect both hoses from purge solenoid valve.</li> <li>• Blow air through purge solenoid valve.</li> <li>• Does air blow through?</li> </ul>	Yes	Replace purge solenoid valve. Then go to Step 12.
		No	Go to next step.
11	<b>INSPECT PCV VALVE OPERATION</b> <ul style="list-style-type: none"> <li>• Inspect PCV valve operation. (See 01–03A–59 Pressure Regulator Control Inspection.)</li> <li>• Is PCV valve okay?</li> </ul>	Yes	Go to next step.
		No	Replace PCV valve, then go to next step.
12	<b>VERIFY TROUBLESHOOTING OF DTC P0172 COMPLETED</b> <ul style="list-style-type: none"> <li>• Make sure to reconnect all disconnected connectors.</li> <li>• Turn ignition key to ON (Engine OFF).</li> <li>• Clear DTC from memory using WDS or equivalent.</li> <li>• Run OBD-II DRIVE MODE 1, 2 and 3.</li> <li>• Is PENDING CODE of same DTC present?</li> </ul>	Yes	Replace PCM, then go to next step.
		No	Go to next step.
13	<b>VERIFY AFTER REPAIR PROCEDURE</b> <ul style="list-style-type: none"> <li>• Perform “After Repair Procedure”. (See 01–02A–10 AFTER REPAIR PROCEDURE [ZM].)</li> <li>• Is there any DTC present?</li> </ul>	Yes	Go to applicable DTC inspection. (See 01–02A–15 DTC TABLE [ZM].)
		No	Troubleshooting completed.

01–02A

### DTC P0300 [ZM]

A3U010201085W06

DTC P0300	Random misfire detection
<b>DETECTION CONDITION</b>	<ul style="list-style-type: none"> <li>• PCM monitors CKP sensor input signal interval time. PCM calculates the change of the interval time for each cylinder. If the change of interval time exceeds the preprogrammed criteria, PCM detects a misfire in the corresponding cylinder. While the engine is running, PCM counts the number of misfires that occurred at <b>200 crankshaft revolutions</b> and <b>1,000 crankshaft revolutions</b> and calculates misfire ratio for each crankshaft revolution. If the ratio exceeds the preprogrammed criteria, PCM determines that a misfire occurred, which can damage the catalytic converter or affect emission performance.</li> </ul> <p><b>Diagnostic support note</b></p> <ul style="list-style-type: none"> <li>• This is a continuous monitor (MISFIRE).</li> <li>• MIL illuminates if PCM detects the misfire which affects emission performance in two consecutive drive cycles.</li> <li>• PENDING CODE is available if PCM detects the misfire which affects emission performance during first drive cycle.</li> <li>• MIL flashes if PCM detects the misfire which can damage the catalytic converter during first drive cycle. Therefore, PENDING CODE is not available while MIL flashes.</li> <li>• FREEZE FRAME DATA is available.</li> <li>• DTC is stored in PCM memory.</li> </ul>

## ON-BOARD DIAGNOSTIC [ENGINE CONTROL SYSTEM (ZM)]

<b>DTC P0300</b>	<b>Random misfire detection</b>
<b>POSSIBLE CAUSE</b>	<ul style="list-style-type: none"> <li>• CKP sensor malfunction</li> <li>• CMP sensor malfunction</li> <li>• Ignition coil malfunction</li> <li>• High-tension lead malfunction</li> <li>• MAF sensor contamination</li> <li>• Excess air suction in intake-air system (between MAF sensor and dynamic chamber)</li> <li>• Fuel pump malfunction</li> <li>• Fuel pressure regulator malfunction</li> <li>• Fuel line clogged</li> <li>• Fuel filter clogged</li> <li>• Fuel leakage in fuel line</li> <li>• Purge control solenoid valve malfunction</li> <li>• PCV valve malfunction</li> <li>• EGR valve malfunction</li> <li>• Vacuum hoses damaged or improper connection</li> <li>• Related connector and terminal malfunction</li> <li>• Related wiring harness malfunction</li> <li>• Poor fuel quality</li> </ul>

### Diagnostic procedure

STEP	INSPECTION		ACTION
1	<b>VERIFY FREEZE FRAME DATA HAS BEEN RECORDED</b> • Has FREEZE FRAME DATA been recorded?	Yes	Go to next step.
		No	Record FREEZE FRAME DATA on repair order, then go to next step.
2	<b>VERIFY RELATED REPAIR INFORMATION AVAILABILITY</b> • Check for related Service Bulletins availability. • Is any related repair information available?	Yes	Perform repair or diagnosis according to available repair information. • If vehicle is not repaired, go to next step.
		No	Go to next step.
3	<b>VERIFY RELATED PENDING CODE OR STORED DTCs</b> • Turn ignition key to OFF then start engine. • Verify related pending code or stored DTCs. • Are other DTCs present?	Yes	Go to appropriate DTC troubleshooting. (See 01–02A–15 DTC TABLE [ZM].)
		No	Go to next step.
4	<b>VERIFY CURRENT INPUT SIGNAL STATUS (IGNITION KEY TO ON/IDLE)</b> • Access ECT, IAT, MAF, RPM, TP, and VS PIDs using WDS or equivalent. (See 01–40A–7 PCM Inspection Using the SST (WDS or equivalent).) • Is there any signal that is far out of specification when ignition switch is ON and engine runs at idle?	Yes	Inspect suspected circuit and/or part according to inspection results. (See 01–40A–7 PCM Inspection Using the SST (WDS or equivalent).) Then go to Step 23.
		No	Go to next step.
5	<b>VERIFY CURRENT INPUT SIGNAL STATUS UNDER TROUBLE CONDITION</b> • Inspect same PIDs as in Step 4 while simulating FREEZE FRAME DATA condition. • Is there any signal which causes drastic changes?	Yes	Inspect suspected circuit and/or part according to inspection results. (See 01–40A–7 PCM Inspection Using the SST (WDS or equivalent).) Then go to Step 23.
		No	Go to next step.
6	<b>INSPECT CMP SENSOR</b> • Inspect CMP sensor. (See 01–40A–35 CAMSHAFT POSITION (CMP) SENSOR INSPECTION [ZM].) • Is CMP sensor okay?	Yes	Go to next step.
		No	Inspect installation condition and damages on timing belt and gears, repair faulty parts. • If it is okay, replace CMP sensor. Then go to Step 23.
7	<b>VERIFY CKP SENSOR INSTALLATION CONDITION</b> • Check CKP sensor for looseness. • Is CKP sensor loose?	Yes	Retighten CKP sensor, then go to Step 23.
		No	Go to next step.
8	<b>CHECK IGNITION COIL OPERATION AND HIGH-TENSION LEAD WITH TIMING LIGHT</b> • Verify blinking condition on each cylinder using timing light at idle. • Do all cylinders show blinking condition?	Yes	Go to Step 12.
		No	Go to next step.

## ON-BOARD DIAGNOSTIC [ENGINE CONTROL SYSTEM (ZM)]

STEP	INSPECTION	ACTION	
9	<b>CHECK HIGH-TENSION LEADS OF NON-BLINKING CYLINDER</b> <ul style="list-style-type: none"> <li>• Turn ignition key to OFF.</li> <li>• Inspect high-tension leads for installation condition, corrosion on terminal, open lead and damaged cover.</li> <li>• Is condition of high-tension lead okay?</li> </ul>	Yes	Go to next step.
		No	Replace faulty high-tension lead, then go to Step 23.
10	<b>INSPECT POWER SUPPLY TERMINAL AT IGNITION COIL CONNECTOR</b> <ul style="list-style-type: none"> <li>• Disconnect ignition coil connector.</li> <li>• Turn ignition key to ON (Engine OFF).</li> <li>• Measure voltage between ignition coil terminal A (harness-side) and body ground.</li> <li>• Is voltage reading <b>B+</b>?</li> </ul>	Yes	Go to next step.
		No	Check for open circuit between ignition coil connector and ignition switch. Repair or replace wiring harness, then go to Step 23.
11	<b>INSPECT IGNITION COIL RESISTANCE</b> <ul style="list-style-type: none"> <li>• Check ignition coil resistance. (See 01-18-2 IGNITION COIL INSPECTION.)</li> <li>• Is coil resistance okay?</li> </ul>	Yes	Go to Step 23.
		No	Replace ignition coil, then go to Step 23.
12	<b>INSPECT MAF SIGNAL</b> <ul style="list-style-type: none"> <li>• Start engine.</li> <li>• Access MAF PID using WDS or equivalent.</li> <li>• Verify that MAF PID changes quickly according to race engine RPM.</li> <li>• Is MAF PID response okay?</li> </ul>	Yes	Go to next step.
		No	Replace MAF sensor, then go to Step 23.
13	<b>INSPECT EXCESSIVE AIR SUCTION IN INTAKE-AIR SYSTEM</b> <ul style="list-style-type: none"> <li>• Inspect for air leakage at following:                             <ul style="list-style-type: none"> <li>— Between MAF sensor and throttle body</li> <li>— Between throttle body and dynamic chamber</li> </ul> </li> <li>• Is there malfunction?</li> </ul>	Yes	Repair or replace suspected part, then go to Step 23.
		No	Go to next step.
14	<b>INSPECT FUEL LINE PRESSURE</b> <ul style="list-style-type: none"> <li>• Inspect fuel line pressure. (See 01-14-6 FUEL PRESSURE INSPECTION.)</li> <li>• Is fuel line pressure okay?</li> </ul>	Yes	Go to Step 18.
		No	If fuel line pressure is too high, go to next step. If fuel line pressure is too low, go to Step 16.
15	<b>VERIFY VACUUM LEADING TO PRESSURE REGULATOR</b> <ul style="list-style-type: none"> <li>• Disconnect vacuum hose from pressure regulator.</li> <li>• Start engine.</li> <li>• Is vacuum felt at opening end of vacuum hose?</li> </ul>	Yes	Check following: <ul style="list-style-type: none"> <li>• Fuel pump maximum pressure (See 01-14-15 FUEL PUMP UNIT INSPECTION.)</li> <li>• Fuel return hose for clogging                                     <ul style="list-style-type: none"> <li>— If all above are okay, replace pressure regulator.</li> </ul> </li> </ul> Then go to Step 23.
		No	Verify vacuum hoses are connected correctly. <ul style="list-style-type: none"> <li>• If okay, replace pressure regulator control solenoid valve.</li> <li>• If not, reconnect vacuum hose in proper position.</li> </ul> Then go to Step 23.
16	<b>INSPECT FUEL PUMP MAXIMUM PRESSURE</b> <ul style="list-style-type: none"> <li>• Inspect fuel pump maximum pressure. (See 01-14-15 FUEL PUMP UNIT INSPECTION.)</li> <li>• Is fuel pump maximum pressure <b>within 450—630 kPa {4.5—6.5 kgf/cm<sup>2</sup>, 64—92 psi}</b>?</li> </ul>	Yes	Go to next step.
		No	Inspect fuel pump circuit for open or poor connection. Repair or replace suspected circuit, then go to Step 23. <ul style="list-style-type: none"> <li>• If okay, replace fuel pump, then go to Step 23.</li> </ul>
17	<b>INSPECT FUEL LINE FROM FUEL PUMP TO FUEL DELIVERY PIPE</b> <ul style="list-style-type: none"> <li>• Visually inspect for fuel leakage in fuel line for any leakage.</li> <li>• Is any fuel leakage found?</li> </ul>	Yes	Replace suspected fuel line, then go to Step 23.
		No	Inspect fuel filters for following: <ul style="list-style-type: none"> <li>• Restriction or clogging at fuel filter (high-pressure).</li> <li>• Foreign material or stain inside fuel filter (low-pressure)</li> </ul> Perform following actions as result. <ul style="list-style-type: none"> <li>• If restriction or clogging is found at fuel filter (high-pressure), replace fuel filter (high-pressure).</li> <li>• If foreign material or stain is found inside fuel filter (low-pressure), clean fuel tank and fuel filter (low-pressure).</li> <li>• If all items above are okay, replace pressure regulator.</li> </ul> Then, go to Step 23.

01-02A

## ON-BOARD DIAGNOSTIC [ENGINE CONTROL SYSTEM (ZM)]

STEP	INSPECTION	ACTION	
18	<b>INSPECT ENGINE COMPRESSION</b> <ul style="list-style-type: none"> <li>• Inspect engine compression. (See 01–10A–8 COMPRESSION INSPECTION [ZM].)</li> <li>• Is it okay?</li> </ul>	Yes	Go to next step.
		No	Implement engine overhaul for repairs, then go to Step 23.
19	<b>INSPECT PURGE CONTROL SOLENOID VALVE FOR OPERATION</b> <ul style="list-style-type: none"> <li>• Inspect purge solenoid valve. (See 01–16–12 PURGE SOLENOID VALVE INSPECTION.)</li> <li>• Is purge control solenoid valve operation okay?</li> </ul>	Yes	Go to next step.
		No	Replace purge control solenoid valve, then go to Step 23.
20	<b>INSPECT PCV VALVE OPERATION</b> <ul style="list-style-type: none"> <li>• Turn ignition key to OFF.</li> <li>• Remove PCV valve and check valve operation. (See 01–16–18 POSITIVE CRANKCASE VENTILATION (PCV) VALVE INSPECTION.)</li> <li>• Is PCV valve operation okay?</li> </ul>	Yes	Replace PCV valve, then go to Step 23.
		No	Go to next step.
21	<b>INSPECT EGR VALVE FOR OPERATION</b> <ul style="list-style-type: none"> <li>• Remove EGR valve.</li> <li>• Visually check for stuck open condition.</li> <li>• Is EGR valve stuck open?</li> </ul>	Yes	Repair or replace EGR valve, then go to Step 23.
		No	Go to next step.
22	<b>INSPECT SEALING OF ENGINE COOLANT PASSAGE</b> <p><b>Warning</b></p> <ul style="list-style-type: none"> <li>• <b>Removing radiator cap when radiator is hot is dangerous. Scalding coolant and steam may shoot out and cause serious injury.</b></li> <li>• <b>When removing radiator cap, wrap thick cloth around and turn it slowly.</b></li> </ul> <ul style="list-style-type: none"> <li>• Remove radiator cap.</li> <li>• Implement procedure to bleed air from engine coolant, then run engine at idle.</li> <li>• Is there any small bubble which makes engine coolant white at filling opening?</li> </ul> <p><b>Note</b></p> <ul style="list-style-type: none"> <li>• Large bubbles are normal since they are remaining air coming out from engine coolant passage.</li> </ul>	Yes	Air gets in from poor sealing on head gasket or other areas between combustion chamber and engine coolant passage. Repair or replace faulty parts, then go to next step.
		No	Go to next step.
23	<b>VERIFY TROUBLESHOOTING OF MISFIRE DTC COMPLETED</b> <ul style="list-style-type: none"> <li>• Make sure to reconnect all disconnected connectors.</li> <li>• Turn ignition key to ON (Engine OFF).</li> <li>• Clear DTC from memory using WDS or equivalent.</li> <li>• Start engine and perform OBD-II DRIVE MODE 1. (See 01–02A–11 Mode 1 (PCM adaptive memory procedure drive mode).)</li> <li>• Is PENDING CODE of same DTC present?</li> </ul>	Yes	Replace PCM, then go to next step.
		No	Go to next step.
24	<b>VERIFY AFTER REPAIR PROCEDURE</b> <ul style="list-style-type: none"> <li>• Perform “After Repair Procedure”. (See 01–02A–10 AFTER REPAIR PROCEDURE [ZM].)</li> <li>• Is there any DTC present?</li> </ul>	Yes	Go to applicable DTC inspection. (See 01–02A–15 DTC TABLE [ZM].)
		No	Troubleshooting completed.

# ON-BOARD DIAGNOSTIC [ENGINE CONTROL SYSTEM (ZM)]

DTC P0301, P0302, P0303, P0304 [ZM]

A3U010201085W07

<p>DTC P0301 DTC P0302 DTC P0303 DTC P0304</p>	<p><b>Cylinder No.1 misfire detected</b> <b>Cylinder No.2 misfire detected</b> <b>Cylinder No.3 misfire detected</b> <b>Cylinder No.4 misfire detected</b></p>
<b>DETECTION CONDITION</b>	<ul style="list-style-type: none"> <li>PCM monitors CKP sensor input signal interval time. PCM calculates the change of the interval time for each cylinder. If the change of interval time exceeds the preprogrammed criteria, PCM detects a misfire in the corresponding cylinder. While the engine is running, PCM counts the number of misfires that occurred at <b>200 crankshaft revolutions</b> and <b>1,000 crankshaft revolutions</b> and calculates misfire ratio for each crankshaft revolution. If the ratio exceeds the preprogrammed criteria, PCM determines that a misfire occurred, which can damage the catalytic converter or affect emission performance.</li> </ul> <p><b>Diagnostic support note</b></p> <ul style="list-style-type: none"> <li>This is a continuous monitor (MISFIRE).</li> <li>MIL illuminates if PCM detects the misfire which affects emission performance in two consecutive drive cycles.</li> <li>PENDING CODE is available if PCM detects the misfire which affects emission performance during first drive cycle.</li> <li>MIL flashes if PCM detects the misfire which can damage the catalytic converter during first drive cycle. Therefore, PENDING CODE is not available while MIL flashes.</li> <li>FREEZE FRAME DATA is available.</li> <li>DTC is stored in PCM memory.</li> </ul>
<b>POSSIBLE CAUSE</b>	<ul style="list-style-type: none"> <li>Spark plug malfunction</li> <li>High-tension lead malfunction</li> <li>Fuel injector malfunction</li> <li>Air suction in intake-air system (between dynamic chamber and cylinder head)</li> <li>Inadequate engine compression due to engine internal malfunction</li> <li>Related connector or terminal malfunction</li> <li>Related wiring harness malfunction</li> </ul>

01-02A

**Diagnostic procedure**

STEP	INSPECTION		ACTION
1	<p><b>VERIFY FREEZE FRAME DATA HAS BEEN RECORDED</b></p> <ul style="list-style-type: none"> <li>Has FREEZE FRAME DATA been recorded?</li> </ul>	Yes	Go to next step.
		No	Record FREEZE FRAME DATA on repair order, then go to next step.
2	<p><b>VERIFY RELATED REPAIR INFORMATION AVAILABILITY</b></p> <ul style="list-style-type: none"> <li>Check for related Service Bulletins availability.</li> <li>Is any related repair information available?</li> </ul>	Yes	Perform repair or diagnosis according to available repair information. <ul style="list-style-type: none"> <li>If vehicle is not repaired, go to next step.</li> </ul>
		No	Go to next step.
3	<p><b>VERIFY RELATED PENDING CODE OR STORED DTCS</b></p> <ul style="list-style-type: none"> <li>Turn ignition key to OFF then start engine.</li> <li>Verify related pending code or stored DTCS.</li> <li>Are other DTCS present?</li> </ul>	Yes	Go to appropriate DTC troubleshooting. (See 01-02A-15 DTC TABLE [ZM].)
		No	Go to next step.
4	<p><b>VERIFY CURRENT INPUT SIGNAL STATUS (IGNITION KEY TO ON /IDLE)</b></p> <ul style="list-style-type: none"> <li>Access ECT, IAT, MAF, RPM, TP and VS PIDs using WDS or equivalent. (See 01-40A-7 PCM Inspection Using the SST (WDS or equivalent).)</li> <li>Is there any signal that is far out of specification when ignition switch is ON and engine runs at idle?</li> </ul>	Yes	Inspect suspected circuit and/or part according to inspection results. Then go to Step 13. (See 01-40A-7 PCM Inspection Using the SST (WDS or equivalent).)
		No	Go to next step.
5	<p><b>VERIFY CURRENT INPUT SIGNAL STATUS UNDER TROUBLE CONDITION</b></p> <ul style="list-style-type: none"> <li>Inspect same PIDs as in Step 4 while simulating FREEZE FRAME DATA condition.</li> <li>Is there any signal which causes drastic changes?</li> </ul>	Yes	Inspect suspected circuit and/or part according to inspection results. Then go to Step 13. (See 01-40A-7 PCM Inspection Using the SST (WDS or equivalent).)
		No	Go to next step.

## ON-BOARD DIAGNOSTIC [ENGINE CONTROL SYSTEM (ZM)]

STEP	INSPECTION	ACTION	
6	<b>INSPECT SPARK PLUG CONDITION</b> <ul style="list-style-type: none"> <li>• Turn ignition key to OFF.</li> <li>• Remove spark plug from suspected cylinder.</li> <li>• Check spark plug condition:                             <ul style="list-style-type: none"> <li>— Cracks</li> <li>— Excessive wear</li> <li>— Gap</li> <li>— Wet</li> </ul> </li> <li>• Is any problem found on spark plug?</li> </ul>	Yes	<ul style="list-style-type: none"> <li>• If spark plug is wet, fuel flooding is suspected. Go to Step 13.</li> <li>• If spark plug has cracks, excessive wear or improper gap, replace faulty spark plug. Then go to Step 13.</li> </ul>
		No	Go to next step.
7	<b>VERIFY HIGH-TENSION LEAD CONDITION</b> <ul style="list-style-type: none"> <li>• Remove high-tension lead.</li> <li>• Check high-tension lead condition and resistance.                             <ul style="list-style-type: none"> <li>— Cracks</li> <li>— Spark shorts to cylinder head through high-tension lead insulator</li> </ul> </li> <li>• Is high-tension lead okay?</li> </ul>	Yes	Go to next step.
		No	Replace high-tension lead, then go to Step 13.
8	<b>INSPECT FOR AIR SUCTION AT INTAKE-AIR SYSTEM</b> <ul style="list-style-type: none"> <li>• Inspect for air leakage at following:                             <ul style="list-style-type: none"> <li>— Around connection of dynamic chamber and intake manifold</li> <li>— Around connection of intake manifold and cylinder head</li> </ul> </li> <li>• Is air leakage found?</li> </ul>	Yes	Repair or replace suspected part, then go to Step 13.
		No	Go to next step.
9	<b>INSPECT FUEL INJECTOR HARNESS</b> <ul style="list-style-type: none"> <li>• Remove intake-air system parts.</li> <li>• Disconnect fuel injector connector on suspected cylinder.</li> <li>• Connect TEST LIGHT to fuel injector connector terminals.</li> <li>• Check dim of light during cranking.</li> <li>• Does TEST LIGHT illuminate?</li> </ul>	Yes	Go to next step.
		No	Check for fuel injector harnesses. Repair or replace if necessary, then go to Step 13.
10	<b>INSPECT SEALING OF ENGINE COOLANT PASSAGE</b> <p><b>Warning</b></p> <ul style="list-style-type: none"> <li>• <b>Removing radiator cap when radiator is hot is dangerous, Scalding coolant and steam may shoot out and cause serious injury.</b></li> <li>• <b>When removing radiator cap, wrap thick cloth around and turn it slowly.</b></li> </ul> <ul style="list-style-type: none"> <li>• Remove radiator cap.</li> <li>• Implement procedure to bleed air from engine coolant, then run engine at idle.</li> <li>• Is there any small bubble which makes engine coolant white at filling opening?</li> </ul> <p><b>Note</b></p> <ul style="list-style-type: none"> <li>• Large bubbles are normal since they are remaining air coming out from engine coolant passage.</li> </ul>	Yes	Air gets in from poor sealing on head gasket or other areas between combustion chamber and engine coolant passage. Repair or replace faulty parts, then go to Step 13.
		No	Go to next step.
11	<b>INSPECT ENGINE COMPRESSION</b> <ul style="list-style-type: none"> <li>• Inspect engine compression. (See 01-10A-8 COMPRESSION INSPECTION [ZM].)</li> <li>• Is engine compression okay?</li> </ul>	Yes	Go to next step.
		No	Overhaul the engine, then go to next step.
12	<b>INSPECT FUEL INJECTOR OPERATION</b> <ul style="list-style-type: none"> <li>• Remove fuel injector from suspected cylinder.</li> <li>• Swap injector with injector on other cylinder.</li> <li>• Start engine and run it at idle.</li> <li>• Does misfire DTC move to cylinder with suspected injector?</li> </ul>	Yes	Replace injector, then go to Step 13.
		No	Go to next step.



# ON-BOARD DIAGNOSTIC [ENGINE CONTROL SYSTEM (ZM)]

01-02A

STEP	INSPECTION		ACTION
13	<b>VERIFY TROUBLESHOOTING OF MISFIRE DTC COMPLETED</b> <ul style="list-style-type: none"> <li>Make sure to reconnect all disconnected connectors.</li> <li>Start engine.</li> <li>Clear DTC from PCM memory using WDS or equivalent.</li> <li>Perform ODB-II DRIVE MODE 1. (See 01-02A-11 Mode 1 (PCM adaptive memory procedure drive mode).)</li> <li>Is same PENDING CODE or stored code of same DTC present?</li> </ul>	Yes	Replace PCM, then go to next step.
		No	Go to next step.
14	<b>VERIFY AFTER REPAIR PROCEDURE</b> <ul style="list-style-type: none"> <li>Perform "After Repair Procedure". (See 01-02A-10 AFTER REPAIR PROCEDURE [ZM].)</li> <li>Is there any DTC present?</li> </ul>	Yes	Go to applicable DTC inspection. (See 01-02A-15 DTC TABLE [ZM].)
		No	Troubleshooting completed.

## DTC P0335 [ZM]

A3U010201085W08

DTC P0335	CKP sensor circuit malfunction
<b>DETECTION CONDITION</b>	<ul style="list-style-type: none"> <li>If PCM does not receive input signal from CKP sensor for <b>4.2 seconds</b> while MAF is <b>2.43 g/s {0.32 lb/min}</b> or above, PCM determines that CKP sensor circuit has a malfunction.</li> </ul> <p><b>Diagnostic support note</b></p> <ul style="list-style-type: none"> <li>This is a continuous monitor (CCM).</li> <li>MIL illuminates if PCM detects the above malfunction conditions during first drive cycle. Therefore, PENDING CODE is not available.</li> <li>FREEZE FRAME DATA is available.</li> <li>DTC is stored in PCM memory.</li> </ul>
<b>POSSIBLE CAUSE</b>	<ul style="list-style-type: none"> <li>CKP sensor malfunction</li> <li>Connector or terminal malfunction</li> <li>CKP sensor is dirty.</li> <li>Short to ground between CKP sensor terminal A and PCM terminal 21</li> <li>Short to ground between CKP sensor terminal B and PCM terminal 22</li> <li>Open circuit between CKP sensor terminal A and PCM terminal 21</li> <li>Open circuit between CKP sensor terminal B and PCM terminal 22</li> <li>CKP sensor pulse wheel malfunction</li> </ul>

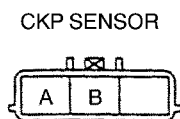
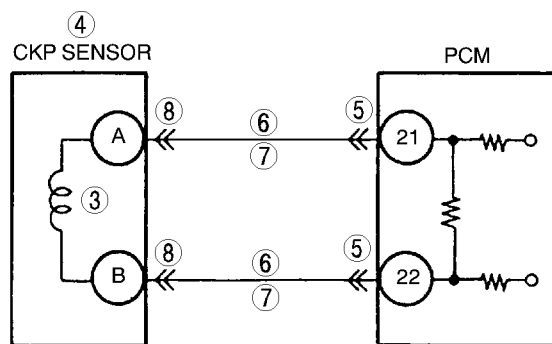

HARNESS SIDE CONNECTOR  
(VIEW FROM TERMINAL SIDE)

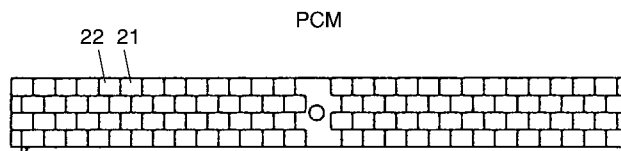

HARNESS SIDE CONNECTOR  
(VIEW FROM HARNESS SIDE)

## ON-BOARD DIAGNOSTIC [ENGINE CONTROL SYSTEM (ZM)]

### Diagnostic procedure

STEP	INSPECTION	ACTION
1	<b>VERIFY FREEZE FRAME DATA HAS BEEN RECORDED</b> <ul style="list-style-type: none"> <li>Has FREEZE FRAME DATA been recorded?</li> </ul>	Yes Go to next step.
		No Record FREEZE FRAME DATA on repair order, then go to next step.
2	<b>VERIFY RELATED REPAIR INFORMATION AVAILABILITY</b> <ul style="list-style-type: none"> <li>Check for related Service Bulletins availability.</li> <li>Is any related repair information available?</li> </ul>	Yes Perform repair or diagnosis according to available repair information. <ul style="list-style-type: none"> <li>If vehicle is not repaired, go to next step.</li> </ul>
		No Go to next step.
3	<b>VERIFY CKP SENSOR VOLTAGE</b> <ul style="list-style-type: none"> <li>Disconnect CKP sensor.</li> <li>Connect voltmeter between CKP sensor terminals A and B (part-side).</li> <li>Check voltage in AC range while cranking the engine.</li> <li>Is any voltage reading?</li> </ul>	Yes Go to Step 5.
		No Go to next step.
4	<b>INSPECT CKP SENSOR RESISTANCE</b> <ul style="list-style-type: none"> <li>Inspect CKP sensor. (See 01-40A-32 CRANKSHAFT POSITION (CKP) SENSOR INSPECTION [ZM].)</li> <li>Is CKP sensor okay?</li> </ul>	Yes Check for poor connection (damaged/pulled-out terminals, corrosion, etc.), bent terminal of CKP sensor connector or plate. <ul style="list-style-type: none"> <li>Repair if necessary, then go to Step 9.</li> </ul>
		No Replace CKP sensor, then go to Step 9.
5	<b>INSPECT PCM CONNECTOR FOR POOR CONNECTION</b> <ul style="list-style-type: none"> <li>Turn ignition key to OFF.</li> <li>Disconnect PCM connector.</li> <li>Check for poor connection at terminals 21 and 22 (damaged/pulled-out terminals, corrosion, etc.).</li> <li>Is there malfunction?</li> </ul>	Yes Repair terminal, then go to Step 9.
		No Go to next step.
6	<b>INSPECT CKP CIRCUIT FOR OPEN CIRCUIT</b> <ul style="list-style-type: none"> <li>Check for continuity between following circuits:               <ul style="list-style-type: none"> <li>— CKP sensor terminal A and PCM terminal 21 (harness-side)</li> <li>— CKP sensor terminal B and PCM terminal 22 (harness-side)</li> </ul> </li> <li>Is there continuity?</li> </ul>	Yes Go to next step.
		No Repair or replace suspected harness, then go to Step 9.
7	<b>INSPECT CKP CIRCUIT FOR SHORT TO GROUND</b> <ul style="list-style-type: none"> <li>Check for continuity between following terminal and body ground:               <ul style="list-style-type: none"> <li>— CKP sensor terminal A (harness-side)</li> <li>— CKP sensor terminal B (harness-side)</li> </ul> </li> <li>Is there continuity?</li> </ul>	Yes Repair or replace suspected harness, then go to Step 9.
		No Go to next step.
8	<b>INSPECT CKP CIRCUITS FOR INTERMEDIATE SHORT</b> <ul style="list-style-type: none"> <li>Check for continuity between CKP sensor terminals A and B.</li> <li>Is there continuity?</li> </ul>	Yes Repair or replace suspected harness, then go to next step.
		No Go to next step.
9	<b>VERIFY TROUBLESHOOTING OF DTC P0335 COMPLETED</b> <ul style="list-style-type: none"> <li>Make sure to reconnect all disconnected connectors.</li> <li>Turn ignition key to ON (Engine OFF).</li> <li>Clear DTC from PCM memory using WDS or equivalent.</li> <li>Start engine.</li> <li>Access MAF PID using WDS or equivalent.</li> </ul> <p><b>Note</b></p> <ul style="list-style-type: none"> <li>MAF PID should indicate <b>above 2.43 g/s {0.32 lb./min}</b> during this test.</li> </ul> <ul style="list-style-type: none"> <li>Is same DTC present?</li> </ul>	Yes Replace PCM, then go to next step.
		No Go to next step.

## ON-BOARD DIAGNOSTIC [ENGINE CONTROL SYSTEM (ZM)]

STEP	INSPECTION	ACTION	
10	<b>VERIFY AFTER REPAIR PROCEDURE</b> <ul style="list-style-type: none"> <li>Perform "After Repair Procedure". (See 01-02A-10 AFTER REPAIR PROCEDURE [ZM].)</li> <li>Is there any DTC present?</li> </ul>	Yes	Go to applicable DTC inspection. (See 01-02A-15 DTC TABLE [ZM].)
		No	Troubleshooting completed.

### DTC P0401 [ZM]

A3U010201086W16

01-02A

DTC P0401	EGR flow insufficient detected
<b>DETECTION CONDITION</b>	<ul style="list-style-type: none"> <li>Difference in intake manifold pressures when EGR is operated and when it is stopped is too small.</li> </ul> <p><b>Diagnostic support note</b></p> <ul style="list-style-type: none"> <li>This is an intermittent monitor (EGR).</li> <li>MIL illuminates if PCM detects the above malfunction conditions in two consecutive drive cycles.</li> <li>DIAGNOSTIC MONITORING TEST RESULTS and PENDING CODE is available if PCM detects the above malfunction condition during first drive cycle.</li> <li>FREEZE FRAME DATA is available.</li> <li>DTC is stored in PCM memory.</li> </ul>
<b>POSSIBLE CAUSE</b>	<ul style="list-style-type: none"> <li>EGR valve malfunction</li> <li>EGR boost sensor malfunction</li> <li>EGR boost sensor solenoid valve malfunction</li> <li>EGR gasket malfunction</li> <li>PCM malfunction</li> </ul>

### Diagnostic procedure

STEP	INSPECTION	ACTION	
1	<b>VERIFY FREEZE FRAME DATA HAS BEEN RECORDED</b> <ul style="list-style-type: none"> <li>Has FREEZE FRAME DATA been recorded?</li> </ul>	Yes	Go to next step.
		No	Record FREEZE FRAME DATA on repair order, then go to next step.
2	<b>VERIFY RELATED REPAIR INFORMATION AVAILABILITY</b> <ul style="list-style-type: none"> <li>Check for related Service Bulletins availability.</li> <li>Is any related repair information available?</li> </ul>	Yes	Perform repair or diagnosis according to available repair information. <ul style="list-style-type: none"> <li>If vehicle is not repaired, go to next step.</li> </ul>
		No	Go to next step.
3	<b>INSPECT FOR OTHER DTCS</b> <ul style="list-style-type: none"> <li>Turn ignition key to OFF then start engine.</li> <li>Have other DTCs been stored?</li> </ul>	Yes	Go to applicable DTC troubleshooting.
		No	Go to next step.
4	<b>INSPECT VACUUM HOSE CONDITION</b> <ul style="list-style-type: none"> <li>Inspect vacuum hoses for clogging, any damages, freeze, or vacuum leakage.</li> <li>Is there malfunction?</li> </ul>	Yes	Replace vacuum hoses, then go to Step 9.
		No	Go to next step.
5	<b>INSPECT EGR VALVE FOR MALFUNCTION</b> <ul style="list-style-type: none"> <li>Inspect EGR valve. (See 01-16-15 EGR VALVE INSPECTION.)</li> <li>Is EGR valve okay?</li> </ul>	Yes	Go to next step.
		No	Replace EGR valve, then go to Step 9.
6	<b>INSPECT EGR BOOST SENSOR FOR MALFUNCTION</b> <ul style="list-style-type: none"> <li>Inspect EGR boost sensor. (See 01-40A-38 EGR BOOST SENSOR INSPECTION [ZM].)</li> <li>Is EGR boost sensor okay?</li> </ul>	Yes	Go to next step.
		No	Replace EGR boost sensor, then go to Step 9.
7	<b>INSPECT EGR BOOST SENSOR SOLENOID VALVE</b> <ul style="list-style-type: none"> <li>Inspect EGR boost sensor solenoid valve. (See 01-16-17 EGR BOOST SENSOR SOLENOID VALVE INSPECTION.)</li> <li>Is EGR boost sensor solenoid valve okay?</li> </ul>	Yes	Go to next step.
		No	Replace EGR boost sensor solenoid valve, then go to Step 9.
8	<b>INSPECT EGR VALVE PASSAGE</b> <ul style="list-style-type: none"> <li>Remove EGR valve.</li> <li>Is gasket installation normal?</li> </ul>	Yes	Go to next step.
		No	Install gasket correctly, then go to next step.

## ON-BOARD DIAGNOSTIC [ENGINE CONTROL SYSTEM (ZM)]

STEP	INSPECTION	ACTION	
9	<b>MONITOR EGR SYSTEM BY DRIVE MODE</b> <ul style="list-style-type: none"> <li>Make sure to reconnect all disconnected connectors.</li> <li>Run OBD-II Drive Mode 1 and 2. (See 01-02A-11 OBD-II DRIVE MODE [ZM].)</li> <li>Check EGR System Monitor completion status using On-Board Readiness Test function.</li> <li>Has EGR system been monitored?</li> </ul>	Yes	Go to next step.
		No	Retry this step.
10	<b>VERIFY TROUBLESHOOTING OF DTC P0401 COMPLETED</b> <ul style="list-style-type: none"> <li>Access DIAGNOSTIC MONITORING TEST RESULTS.</li> <li>Verify TEST ID 10:41:00 value.</li> <li>Is value within specification?</li> </ul>	Yes	Go to next step.
		No	Replace PCM, then go to next step.
11	<b>VERIFY AFTER REPAIR PROCEDURE</b> <ul style="list-style-type: none"> <li>Perform "After Repair Procedure". (See 01-02A-10 AFTER REPAIR PROCEDURE [ZM].)</li> <li>Is there any DTC present?</li> </ul>	Yes	Go to applicable DTC inspection. (See 01-02A-15 DTC TABLE [ZM].)
		No	Troubleshooting completed.

### DTC P0402 [ZM]

A3U010201086W17

DTC P0402	EGR flow excessive detected
<b>DETECTION CONDITION</b>	<ul style="list-style-type: none"> <li>Difference in intake manifold pressures when EGR is operated and when it is stopped is too large.</li> </ul> <b>Diagnostic support note</b> <ul style="list-style-type: none"> <li>This is an intermittent monitor (EGR).</li> <li>MIL illuminates if PCM detects the above malfunction conditions in two consecutive drive cycles.</li> <li>PENDING CODE is available if PCM detects the above malfunction condition during first drive cycle.</li> <li>FREEZE FRAME DATA is available.</li> <li>DTC is stored in PCM memory.</li> </ul>
<b>POSSIBLE CAUSE</b>	<ul style="list-style-type: none"> <li>EGR valve gasket is not installed.</li> <li>EGR valve gasket has been damaged.</li> <li>PCM malfunction</li> </ul>

### Diagnostic procedure

STEP	INSPECTION	ACTION	
1	<b>VERIFY FREEZE FRAME DATA HAS BEEN RECORDED</b> <ul style="list-style-type: none"> <li>Has FREEZE FRAME DATA been recorded?</li> </ul>	Yes	Go to next step.
		No	Record FREEZE FRAME DATA on repair order, then go to next step.
2	<b>VERIFY RELATED REPAIR INFORMATION AVAILABILITY</b> <ul style="list-style-type: none"> <li>Check for related Service Bulletins availability.</li> <li>Is any related repair information available?</li> </ul>	Yes	Perform repair or diagnosis according to available repair information. <ul style="list-style-type: none"> <li>If vehicle is not repaired, go to next step.</li> </ul>
		No	Go to next step.
3	<b>INSPECT FOR OTHER DTCS</b> <ul style="list-style-type: none"> <li>Turn ignition key to OFF then start engine.</li> <li>Have other DTCs been stored?</li> </ul>	Yes	Go to applicable DTC troubleshooting.
		No	Go to next step.
4	<b>INSPECT EGR VALVE GASKET</b> <ul style="list-style-type: none"> <li>Turn ignition key to OFF.</li> <li>Remove EGR valve.</li> <li>Is EGR valve gasket installed?</li> </ul>	Yes	Go to next step.
		No	Install EGR valve gasket, then go to Step 6.
5	<b>INSPECT EGR VALVE GASKET MALFUNCTION</b> <ul style="list-style-type: none"> <li>Does EGR valve gasket have any crack and/or damage?</li> </ul>	Yes	Replace EGR valve gasket, then go to Step 6.
		No	Go to next step.
6	<b>MONITOR EGR SYSTEM BY DRIVE MODE</b> <ul style="list-style-type: none"> <li>Make sure to reconnect all disconnected connectors.</li> <li>Run OBD-II Drive Mode 1 and 2. (See 01-02A-11 OBD-II DRIVE MODE [ZM].)</li> <li>Check EGR System Monitor completion status using On-Board Readiness Test function.</li> <li>Has EGR system been monitored?</li> </ul>	Yes	Go to next step.
		No	Retry this step.

## ON-BOARD DIAGNOSTIC [ENGINE CONTROL SYSTEM (ZM)]

STEP	INSPECTION	ACTION	
7	<b>VERIFY TROUBLESHOOTING OF DTC P0402 COMPLETED</b> <ul style="list-style-type: none"> <li>Make sure to reconnect all disconnected connectors.</li> <li>Access DIAGNOSTIC MONITORING TEST RESULTS.</li> <li>Verify TEST ID 10:41:00 value.</li> <li>Is value within specification?</li> </ul>	Yes	Go to next step.
		No	Replace PCM, then go to next step.
8	<b>VERIFY AFTER REPAIR PROCEDURE</b> <ul style="list-style-type: none"> <li>Perform "After Repair Procedure". (See 01-02A-10 AFTER REPAIR PROCEDURE [ZM].)</li> <li>Is there any DTC present?</li> </ul>	Yes	Go to applicable DTC inspection. (See 01-02A-15 DTC TABLE [ZM].)
		No	Troubleshooting completed.

01-02A

### DTC P0421 [ZM]

A3U010201086W18

DTC P0421	Warm-up catalyst system efficiency below threshold
<b>DETECTION CONDITION</b>	<ul style="list-style-type: none"> <li>PCM compares the number of HO2S (front) and HO2S (rear) inversions for a predetermined time. PCM monitors the number of inversions the rear side performs while the front side inverts for a specified number of times when the following monitoring conditions are met. PCM detects the inversion ratio. If inversion ratio is below threshold, PCM determines that catalyst system has deteriorated.</li> </ul> <p><b>MONITORING CONDITIONS</b></p> <ul style="list-style-type: none"> <li>Engine speed is <b>1,500—3,000 rpm</b>.</li> <li>Calculated load is <b>17—48%(*1)</b>.</li> <li>Vehicle speed is <b>28—120 km/h {17.3—74.5 mph}</b>.</li> </ul> <p>*1: Maximum calculated load value varies depending on engine speed.</p> <p><b>Diagnostic support note</b></p> <ul style="list-style-type: none"> <li>This is an intermittent monitor. (CATALYST)</li> <li>MIL illuminates if PCM detects the above malfunction conditions in two consecutive drive cycles.</li> <li>DIAGNOSTIC MONITORING TEST RESULTS are available.</li> <li>PENDING CODE is stored if PCM detects the above malfunction condition during first drive cycle.</li> <li>FREEZE FRAME DATA is available.</li> <li>DTC is stored in PCM memory.</li> </ul>
<b>POSSIBLE CAUSE</b>	<ul style="list-style-type: none"> <li>WU-TWC deterioration or malfunction</li> <li>Exhaust gas leakage</li> <li>Looseness of HO2S (front)</li> <li>Looseness of HO2S (rear)</li> <li>HO2S (front) malfunction</li> </ul>

### Diagnostic procedure

STEP	INSPECTION	ACTION	
1	<b>VERIFY FREEZE FRAME DATA HAS BEEN RECORDED</b> <ul style="list-style-type: none"> <li>Has FREEZE FRAME DATA been recorded?</li> </ul>	Yes	Go to next step.
		No	Record FREEZE FRAME DATA on repair order, then go to next step.
2	<b>VERIFY RELATED REPAIR INFORMATION AVAILABILITY</b> <ul style="list-style-type: none"> <li>Check for related Service Bulletins availability.</li> <li>Is any related repair information available?</li> </ul>	Yes	Perform repair or diagnosis according to available repair information. <ul style="list-style-type: none"> <li>If vehicle is not repaired, go to next step.</li> </ul>
		No	Go to next step.
3	<b>VERIFY RELATED PENDING CODE OR STORED DTCS</b> <ul style="list-style-type: none"> <li>Turn ignition key to OFF then start engine.</li> <li>Verify related pending code or stored DTCs.</li> <li>Are other DTCs present?</li> </ul>	Yes	Go to appropriate DTC troubleshooting.
		No	Go to next step.
4	<b>INSPECT EXHAUST SYSTEM FOR GAS LEAKAGE</b> <ul style="list-style-type: none"> <li>Visually inspect exhaust gas leakage in exhaust system.</li> <li>Is there any gas leakage?</li> </ul>	Yes	Repair or replace faulty exhaust parts, then go to Step 7.
		No	Go to next step.
5	<b>INSPECT INSTALLATION OF FRONT AND REAR OXYGEN SENSORS</b> <ul style="list-style-type: none"> <li>Inspect for looseness of front and rear oxygen sensors.</li> <li>Is it okay?</li> </ul>	Yes	Go to next step.
		No	Retighten sensor, then go to Step 7.

## ON-BOARD DIAGNOSTIC [ENGINE CONTROL SYSTEM (ZM)]

STEP	INSPECTION	ACTION	
6	<b>INSPECT WU-TWC</b> <ul style="list-style-type: none"> <li>• Clear DTC using WDS or equivalent.</li> <li>• Inspect WU-TWC. (See 01-16-19 WARM UP THREE-WAY CATALYTIC CONVERTER (WU-TWC) INSPECTION.)</li> <li>• Is WU-TWC okay?</li> </ul>	Yes	Replace suspected oxygen sensor, then go to next step.
		No	Replace WU-TWC, then go to next step.
7	<b>VERIFY TROUBLESHOOTING OF DTC P0421 COMPLETED</b> <ul style="list-style-type: none"> <li>• Make sure to reconnect all disconnected connectors.</li> <li>• Turn ignition key to ON (Engine OFF).</li> <li>• Clear DTC from memory using WDS or equivalent.</li> <li>• Start engine and perform OBD-II DRIVE MODE except for MODE 4. (See 01-02A-11 OBD-II DRIVE MODE [ZM].)</li> <li>• Is PENDING CODE of same DTC present?</li> </ul>	Yes	Replace PCM, then go to next step.
		No	Go to next step.
8	<b>VERIFY AFTER REPAIR PROCEDURE</b> <ul style="list-style-type: none"> <li>• Perform "After Repair Procedure". (See 01-02A-10 AFTER REPAIR PROCEDURE [ZM].)</li> <li>• Is there any DTC present?</li> </ul>	Yes	Go to applicable DTC inspection. (See 01-02A-15 DTC TABLE [ZM].)
		No	Troubleshooting completed.

### DTC P0442 [ZM]

A3U010201086W19

DTC P0442	Evaporative emission control system leak detected (small leak)
<b>DETECTION CONDITION</b>	<ul style="list-style-type: none"> <li>• PCM measures the fuel tank pressure (ftp2), which is the vacuum when a specified period has passed after EVAP system is sealed. PCM determines the pressure difference between ftp1 and ftp2. If pressure difference exceeds the threshold, PCM determines that the EVAP system has a small leak. This monitor can activate when the PCM determines that the CONSTANTLY LEAK DETECTED test results are passed.</li> </ul> <p><b>THRESHOLD VALUE</b></p> <ul style="list-style-type: none"> <li>— Fuel tank pressure (ftp2—ftp1): <b>1.17—3.91 kPa {8.78—29.30 mmHg, 0.34—1.15 inHg}</b> <ul style="list-style-type: none"> <li>• Threshold valve varies depends on ECT at engine start BARO.</li> </ul> </li> </ul> <p><b>MONITORING CONDITIONS</b></p> <ul style="list-style-type: none"> <li>— PCM monitors EVAP system when driving under following conditions: <ul style="list-style-type: none"> <li>• Remaining fuel: <b>15—85%</b></li> <li>• ECT at engine start: <b>-10.0 °C—32.5 °C {14.0—90.5 °F}</b></li> <li>• Atmospheric pressure: <b>above 72.2 kPa {542 mmHg, 21.3 inHg}</b></li> <li>• Vehicle speed: <b>39.5—120.3 km/h {24.5—74.7 mph}</b></li> <li>• Engine speed: <b>1,000—4,000 rpm</b></li> <li>• Calculated load: <b>9—65%</b></li> <li>• Throttle opening angle: <b>3.1—12.5%</b></li> <li>• IAT during monitor: <b>-10—60 °C {14—140 °F}</b></li> </ul> </li> </ul> <p><b>Diagnostic support note</b></p> <ul style="list-style-type: none"> <li>• This is an intermittent monitor (Evaporative leak monitor).</li> <li>• MIL illuminates if PCM detects the above malfunction condition in two consecutive drive cycles.</li> <li>• DIAGNOSTIC MONITORING TEST RESULTS and PENDING CODE are stored if PCM detects the above malfunction condition during first drive cycle.</li> <li>• FREEZE FRAME DATA is available.</li> <li>• DTC is stored in PCM memory.</li> </ul>
<b>POSSIBLE CAUSE</b>	<ul style="list-style-type: none"> <li>• Purge solenoid valve malfunction</li> <li>• Canister drain cut valve (CDCV) malfunction</li> <li>• Tank pressure control valve (TPCV) malfunction</li> <li>• Pressure control valve malfunction</li> <li>• Loose or defective fuel filler cap</li> <li>• Charcoal canister malfunction</li> <li>• Catch tank malfunction</li> <li>• Rollover valve malfunction</li> <li>• Cracked fuel tank</li> <li>• Fuel tank component parts poorly installed</li> <li>• EVAP hose damaged or loose</li> </ul>

## ON-BOARD DIAGNOSTIC [ENGINE CONTROL SYSTEM (ZM)]

### Diagnostic procedure

STEP	INSPECTION	ACTION
1	<b>VERIFY FREEZE FRAME DATA HAS BEEN RECORDED</b> <ul style="list-style-type: none"> <li>Has FREEZE FRAME DATA been recorded?</li> </ul>	Yes Go to next step.
		No Record FREEZE FRAME DATA on repair order, then go to next step.
2	<b>VERIFY RELATED REPAIR INFORMATION AVAILABILITY</b> <ul style="list-style-type: none"> <li>Check for related Service Bulletins availability.</li> <li>Is any related repair information available?</li> </ul>	Yes Perform repair or diagnosis according to available repair information. <ul style="list-style-type: none"> <li>If vehicle is not repaired, go to next step.</li> </ul>
		No Go to next step.
3	<b>VERIFY RELATED PENDING CODE OR STORED DTCs</b> <ul style="list-style-type: none"> <li>Turn ignition key to OFF then ON (Engine OFF).</li> <li>Verify related pending code or stored DTCs.</li> <li>Are DTCs P0443 and/or P1449 present?</li> </ul>	Yes Go to appropriate DTC inspection.
		No Go to next step.
4	<b>INSPECT FUEL-FILLER CAP</b> <ul style="list-style-type: none"> <li>Verify fuel-filler cap is neither loose nor damaged.</li> <li>Is it okay?</li> </ul> <p><b>Note</b></p> <ul style="list-style-type: none"> <li>When fuel-filler caps other than OEM caps are attached, it is considered a malfunction.</li> </ul>	Yes Go to next step.
		No Retighten fuel-filler cap or replace it if it is damaged. Then go to Step 15.
5	<b>INSPECT WHOLE EVAP CONTROL SYSTEM</b> <ul style="list-style-type: none"> <li>Implement "01-03B ENGINE CONTROL SYSTEM OPERATION INSPECTION [FS], Evaporative System Leak Inspection Using Vacuum Pump, Whole system inspection". (See 01-03B-55 Whole system inspection.)</li> <li>Does voltage change under to specified readings and hold for <b>minimum of 2 minutes</b>?</li> </ul>	Yes No leaks were detected in EVAP control system at this time. Go to Step 15.
		No If evaporative emission tester is available, go to Step 14. If not, go to next step.
6	<b>INSPECT FOR LEAKAGE FROM CHARCOAL CANISTER TO FUEL TANK</b> <ul style="list-style-type: none"> <li>Implement "01-03B ENGINE CONTROL SYSTEM OPERATION INSPECTION [FS], Evaporative System Leak Inspection Using Vacuum Pump, Inspection from charcoal canister to fuel tank". (See 01-03B-55 Inspection from charcoal canister to fuel tank.)</li> <li>Does voltage change under to specified readings and hold for a <b>minimum of 2 minutes</b>?</li> </ul>	Yes Go to Step 9.
		No Go to next step.
7	<b>INSPECT ATTACHED ACCESSORIES ON FUEL TANK</b> <ul style="list-style-type: none"> <li>Remove fuel tank and visually inspect for damage, insufficient sealing or poorly attached accessories on fuel tank, such as fuel gauge.</li> <li>Is it okay?</li> </ul>	Yes Go to next step.
		No Repair or replace fuel tank or sealing, then go to Step 15.
8	<b>INSPECT ROLLOVER VALVE</b> <ul style="list-style-type: none"> <li>Remove rollover valve and inspect for damage.</li> <li>Is it okay?</li> </ul>	Yes Inspect for detached, incorrectly installed or cracked hoses on fuel tank and from charcoal canister to fuel tank. Repair or replace as necessary. Then go to step 15.
		No Replace rollover valve, then go to Step 15.
9	<b>INSPECT LEAKAGE BETWEEN CHARCOAL CANISTER AND PURGE SOLENOID VALVE</b> <ul style="list-style-type: none"> <li>Implement "01-03B ENGINE CONTROL SYSTEM OPERATION INSPECTION [FS], Evaporative System Leak Inspection Using Vacuum Pump, Inspection from charcoal canister to purge solenoid valve". (See 01-03B-55 Inspection from charcoal canister to purge solenoid valve.)</li> <li>Does voltage change under to specified readings and hold for a <b>minimum of 2 minutes</b>?</li> </ul>	Yes Go to Step 15.
		No Go to next step.

01-02A

## ON-BOARD DIAGNOSTIC [ENGINE CONTROL SYSTEM (ZM)]

STEP	INSPECTION	ACTION	
10	<b>INSPECT CATCH TANK</b> <ul style="list-style-type: none"> <li>• Remove catch tank and inspect for plugging, damages and pinhole using vacuum pump.</li> <li>• Is it okay?</li> </ul>	Yes	Go to next step.
		No	Replace catch tank, then go to Step 15.
11	<b>INSPECT PURGE SOLENOID VALVE</b> <ul style="list-style-type: none"> <li>• Remove purge solenoid valve and inspect for damage and air leakage.</li> <li>• Is it okay?</li> </ul>	Yes	Go to next step.
		No	Replace purge solenoid valve, then go to Step 15.
12	<b>INSPECT CHARCOAL CANISTER</b> <ul style="list-style-type: none"> <li>• Remove charcoal canister and inspect for damage and pinhole.</li> <li>• Is it okay?</li> </ul>	Yes	Go to next step.
		No	Replace charcoal canister, then go to Step 15.
13	<b>INSPECT CDCV</b> <ul style="list-style-type: none"> <li>• Remove CDCV and inspect for damage and air leakage.</li> <li>• Is it okay?</li> </ul>	Yes	Inspect and repair or replace detached, incorrectly installed or cracked hoses from charcoal canister to CDCV. Then go to Step 15.
		No	Replace CDCV, then go to Step 15.
14	<b>INSPECT FOR LEAKAGE IN EVAPORATIVE CONTROL SYSTEM</b> <ul style="list-style-type: none"> <li>• Inspect evaporative control system for leakage using evaporative emission tester. (See 01-16-13 FUEL-FILLER CAP INSPECTION.)</li> <li>• Is any leakage found?</li> </ul>	Yes	Repair or replace faulty area, then go to next step.
		No	Go to next step.
15	<b>VERIFY MONITORING CONDITION FOR EVAPORATIVE SYSTEM TEST</b> <ul style="list-style-type: none"> <li>• Turn ignition key to ON (Engine OFF).</li> <li>• Verify that following conditions are met. <ul style="list-style-type: none"> <li>— BARO: <b>72.2 kPa {542 mmHg, 21.3 inHg} or higher</b></li> <li>— ECT: <b>-10.0—22.0 °C {14.0—72.0 °F} [at atmospheric pressure 72.2 kPa {542 mmHg, 21.3 inHg}]</b></li> <li>— IAT: <b>-10—60 °C {14—140 °F}</b></li> <li>— Fuel tank level: <b>15—85%</b></li> </ul> </li> <li>• Is there any PID that is out of specification?</li> </ul>	Yes	Go to next step.
		No	Go to Step 18.
16	<b>VERIFY EVAP SYSTEM REPAIRED</b> <ul style="list-style-type: none"> <li>• Carry out evaporative system test even if it is not test condition. (See 01-03B-54 Evaporative System Leak Inspection Using Leak Tester.)</li> <li>• Is system test result of small leak okay?</li> </ul>	Yes	EVAP system repaired. Go to Step 22.
		No	Go to next step.
17	<b>VERIFY MONITORING CONDITION FOR EVAPORATIVE SYSTEM TEST OR DRIVE MODE 4</b> <ul style="list-style-type: none"> <li>• Turn ignition key to ON (Engine OFF).</li> <li>• Verify that following conditions are met. <ul style="list-style-type: none"> <li>— BARO: <b>72.2 kPa {542 mmHg, 21.3 inHg} or higher</b></li> <li>— ECT: <b>-10.0—22.0 °C {14.0—72.0 °F} [at atmospheric pressure 72.2 kPa {542 mmHg, 21.3 inHg}]</b></li> <li>— IAT: <b>-10—60 °C {14—140 °F}</b></li> <li>— Fuel tank level: <b>15—85%</b></li> </ul> </li> <li>• Is there any PID that is out of specification?</li> </ul>	Yes	Take corrective action (e.g. cool down engine), then repeat this step.  <b>Note</b> <ul style="list-style-type: none"> <li>• Readings need to be in the indicated ranges to perform Drive Mode.</li> </ul>
		No	Then go to next step.
18	<b>DECIDE ON AFTER REPAIR PROCEDURE ACCORDING TO REPAIR SHOP CONDITION</b> <ul style="list-style-type: none"> <li>• Clear DTC from memory using WDS or equivalent.</li> <li>• Is repair shop possible to perform Drive Mode 4?</li> </ul>	Yes	Go to Step 20.
		No	Go to next step.
19	<b>VERIFY EVAP SYSTEM REPAIRED BY EVAPORATIVE SYSTEM TEST</b> <ul style="list-style-type: none"> <li>• Carry out evaporative system test. (See 01-03B-54 Evaporative System Leak Inspection Using Leak Tester.)</li> <li>• Is system test result okay?</li> </ul>	Yes	EVAP system repaired. Go to Step 22.
		No	Replace PCM, then go to Step 22.



# ON-BOARD DIAGNOSTIC [ENGINE CONTROL SYSTEM (ZM)]

01-02A

STEP	INSPECTION		ACTION
20	<b>MONITOR EVAP SYSTEM BY DRIVE MODE 4</b> <ul style="list-style-type: none"> <li>Run Drive Mode 4. (See 01-02B-12 Mode 4 (EVAP system repair verification drive mode).)</li> <li>Stop vehicle and access ON BOARD SYSTEM READINESS TESTS to inspect Drive Mode completion status.</li> <li>Has EVAPORATIVE PURGE SYSTEM been monitored?</li> </ul>	Yes	Go to next step.
		No	Go back to Step 17.
21	<b>VERIFY EVAP SYSTEM REPAIRED</b> <ul style="list-style-type: none"> <li>Access DIAGNOSTIC MONITORING TEST RESULTS.</li> <li>Is it below MAX value?</li> </ul>	Yes	Go to next step.
		No	Replace PCM, then go next step.
22	<b>VERIFY AFTER REPAIR PROCEDURE</b> <ul style="list-style-type: none"> <li>Perform "After Repair Procedure". (See 01-02B-9 AFTER REPAIR PROCEDURE [FS].)</li> <li>Is there any DTC present?</li> </ul>	Yes	Go to applicable DTC inspection. (See 01-02B-15 DTC TABLE [FS].)
		No	Troubleshooting completed.

## DTC P0443 [ZM]

A3U010201086W20

DTC P0443	Evaporative emission solenoid system purge control valve circuit malfunction
<b>DETECTION CONDITION</b>	<ul style="list-style-type: none"> <li>PCM monitors input voltages from purge solenoid valve. If voltage at PCM terminal 67 remains low or high, PCM determines that purge solenoid valve circuit has malfunction.</li> </ul> <p><b>Diagnostic support note</b></p> <ul style="list-style-type: none"> <li>This is a diagnostic support DTC (monitored one per key cycle).</li> <li>MIL does not illuminate.</li> <li>FREEZE FRAME DATA is not available.</li> <li>DTC is not stored in PCM memory.</li> </ul>
<b>POSSIBLE CAUSE</b>	<ul style="list-style-type: none"> <li>Purge solenoid valve malfunction</li> <li>Connector or terminal malfunction</li> <li>Short to ground in wiring between purge solenoid valve terminal B and PCM terminal 67</li> <li>Open circuit in wiring between main relay terminal D and purge solenoid valve terminal A</li> <li>Open circuit in wiring between purge solenoid valve terminal B and PCM terminal 67</li> <li>Short to power circuit between purge solenoid valve terminal B and PCM terminal 67</li> <li>PCM malfunction</li> </ul>

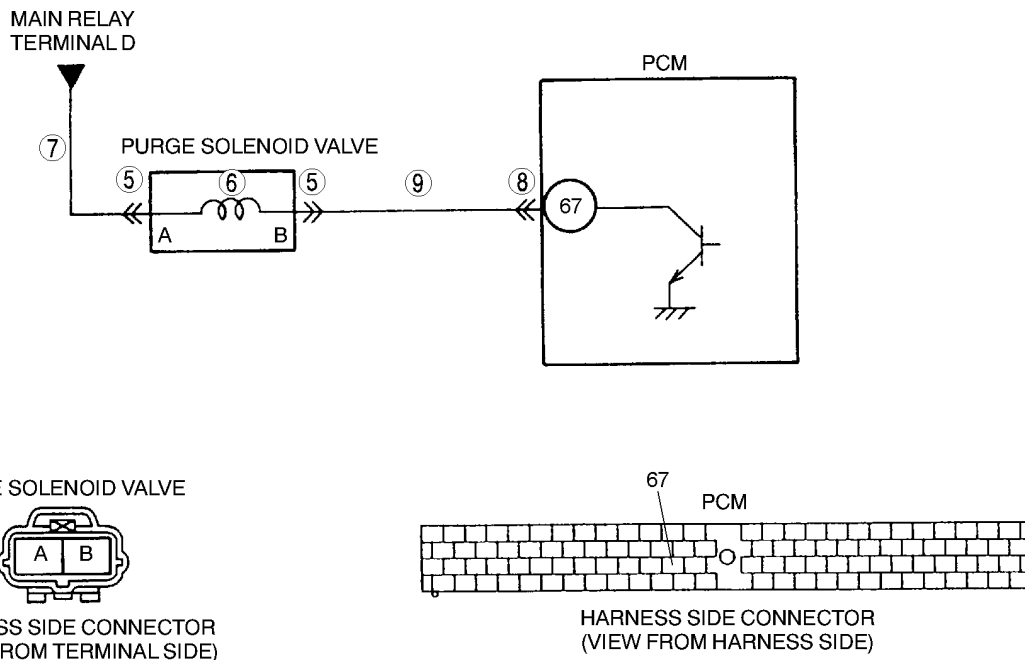

## ON-BOARD DIAGNOSTIC [ENGINE CONTROL SYSTEM (ZM)]

### Diagnostic procedure

STEP	INSPECTION	ACTION	
1	<b>VERIFY RELATED REPAIR INFORMATION AVAILABILITY</b> <ul style="list-style-type: none"> <li>• Check for related Service Bulletins availability.</li> <li>• Is any related repair information available?</li> </ul>	Yes	Perform repair or diagnosis according to available repair information. <ul style="list-style-type: none"> <li>• If vehicle is not repaired, go to next step.</li> </ul>
		No	Go to next step.
2	<b>CLASSIFY INTERMITTENT CONCERN OR CONTINUOUS CONCERN</b> <ul style="list-style-type: none"> <li>• Turn ignition key to OFF then start engine.</li> <li>• Is same DTC present?</li> </ul>	Yes	Go to next step.
		No	Refer to intermittent concern. (See 01-03A-4 INTERMITTENT CONCERN TROUBLESHOOTING [ZM].)
3	<b>CLASSIFY OPEN CIRCUIT OR SHORT TO GROUND MALFUNCTION</b> <ul style="list-style-type: none"> <li>• Disconnect purge solenoid valve tube that is connected to intake manifold.</li> <li>• Connect vacuum pump to purge solenoid valve.</li> <li>• Pump vacuum pump several times and stop.</li> <li>• Wait <b>a few seconds</b>.</li> <li>• Is vacuum maintained?</li> </ul>	Yes	Go to Step 5.
		No	Go to next step.
4	<b>INSPECT PASSAGE CONTROL OF PURGE SOLENOID VALVE</b> <ul style="list-style-type: none"> <li>• Turn ignition key to OFF.</li> <li>• Disconnect purge solenoid valve connector.</li> <li>• Pump vacuum pump several times and wait <b>a few seconds</b>.</li> <li>• Is vacuum maintained?</li> </ul>	Yes	Repair or replace harness for short to ground, then go to Step 10.
		No	Replace purge solenoid valve, then go to Step 10.
5	<b>INSPECT PURGE SOLENOID VALVE CONNECTOR FOR POOR CONNECTION</b> <ul style="list-style-type: none"> <li>• Turn ignition key to OFF.</li> <li>• Check for poor connection (damaged/pulled-out pins, corrosion, etc.).</li> <li>• Is there malfunction?</li> </ul>	Yes	Repair or replace terminal, then go to Step 10.
		No	Go to next step.
6	<b>INSPECT PURGE SOLENOID VALVE</b> <ul style="list-style-type: none"> <li>• Measure resistance between purge solenoid valve terminals (part-side).</li> <li>• Is resistance <b>within 22—26 ohms</b>?</li> </ul>	Yes	Go to next step.
		No	Replace purge solenoid valve, then go to Step 10.
7	<b>INSPECT PURGE SOLENOID VALVE POWER SUPPLY CIRCUIT FOR OPEN CIRCUIT</b> <ul style="list-style-type: none"> <li>• Turn ignition key to ON (Engine OFF).</li> <li>• Measure voltage between purge solenoid valve connector terminal A and body ground.</li> <li>• Is voltage <b>B+</b>?</li> </ul>	Yes	Go to next step.
		No	Repair or replace harness for open, then go to Step 10.
8	<b>INSPECT PCM CONNECTOR FOR POOR CONNECTION</b> <ul style="list-style-type: none"> <li>• Turn ignition key to OFF.</li> <li>• Disconnect PCM connector.</li> <li>• Check for poor connection (damaged/pulled-out pins, corrosion, etc.).</li> <li>• Is there malfunction?</li> </ul>	Yes	Repair or replace terminal, then go to Step 10.
		No	Go to next step.
9	<b>INSPECT PURGE SOLENOID VALVE CONTROL CIRCUIT</b> <ul style="list-style-type: none"> <li>• Connect breakout box with PCM disconnected.</li> <li>• Turn ignition key to ON (Engine OFF).</li> <li>• Measure voltage between purge solenoid valve terminal B (harness-side) and body ground.</li> <li>• Is voltage <b>B+</b>?</li> </ul>	Yes	Repair or replace harness for short to power, then go to next step.
		No	Check for continuity between purge solenoid valve terminal B (harness-side) and breakout box terminal 67. <ul style="list-style-type: none"> <li>• If there is continuity, go to next step.</li> <li>• If there is no continuity, repair or replace harness for open, then go to next step.</li> </ul>
10	<b>VERIFY TROUBLESHOOTING OF DTC P0443 COMPLETED</b> <ul style="list-style-type: none"> <li>• Make sure to reconnect all disconnected connectors.</li> <li>• Turn ignition key to OFF then start engine.</li> <li>• Is same DTC present?</li> </ul>	Yes	Replace PCM, then go to next step.
		No	Go to next step.

## ON-BOARD DIAGNOSTIC [ENGINE CONTROL SYSTEM (ZM)]

STEP	INSPECTION	ACTION	
11	<b>VERIFY AFTER REPAIR PROCEDURE</b> <ul style="list-style-type: none"> <li>Perform "After Repair Procedure". (See 01-02A-10 AFTER REPAIR PROCEDURE [ZM].)</li> <li>Is there any DTC present?</li> </ul>	Yes	Go to applicable DTC inspection. (See 01-02A-15 DTC TABLE [ZM].)
		No	Troubleshooting completed.

### DTC P0451 [ZM]

A3U010201086W21

01-02A

DTC P0451	Fuel tank pressure sensor performance problem
<b>DETECTION CONDITION</b>	<ul style="list-style-type: none"> <li>Difference in fuel tank pressure, which PCM monitors while operating evaporative leak monitor function or purge solenoid valve is intentionally closed, is too small or too large.</li> </ul> <p><b>Diagnostic support note</b></p> <ul style="list-style-type: none"> <li>This is a continuous monitor (CCM).</li> <li>MIL illuminates if PCM detects the above malfunction condition in two consecutive drive cycles.</li> <li>PENDING CODE is available if PCM detects the above malfunction condition during first drive cycle.</li> <li>FREEZE FRAME DATA is available.</li> <li>DTC is stored in PCM memory.</li> </ul>
<b>POSSIBLE CAUSE</b>	<ul style="list-style-type: none"> <li>Fuel tank pressure sensor malfunction</li> <li>Purge solenoid valve malfunction</li> <li>CDCV malfunction</li> <li>Poor connection of CDCV, fuel tank pressure sensor and/or PCM</li> <li>Short circuit in wiring at CDCV</li> <li>Charcoal canister clogging</li> </ul>

### Diagnostic procedure

STEP	INSPECTION	ACTION	
1	<b>VERIFY FREEZE FRAME DATA HAS BEEN RECORDED</b> <ul style="list-style-type: none"> <li>Has FREEZE FRAME DATA been recorded?</li> </ul>	Yes	Go to next step.
		No	Record FREEZE FRAME DATA on repair order, then go to next step.
2	<b>VERIFY RELATED REPAIR INFORMATION AVAILABILITY</b> <ul style="list-style-type: none"> <li>Check for related Service Bulletins availability.</li> <li>Is any related repair information available?</li> </ul>	Yes	Perform repair or diagnosis according to available repair information. <ul style="list-style-type: none"> <li>If vehicle is not repaired, go to next step.</li> </ul>
		No	Go to next step.
3	<b>INSPECT FOR OTHER DTCS</b> <ul style="list-style-type: none"> <li>Turn ignition key to OFF then start engine.</li> <li>Verify stored DTC.</li> <li>Have DTCs P0443 and/or P1449 been stored?</li> </ul>	Yes	Go to appropriate DTC inspection.
		No	Go to next step.
4	<b>INSPECT PURGE SOLENOID VALVE OPERATION</b> <ul style="list-style-type: none"> <li>Inspect purge solenoid valve. (See 01-16-12 PURGE SOLENOID VALVE INSPECTION.)</li> <li>Is purge solenoid valve okay?</li> </ul>	Yes	Go to next step.
		No	Replace purge solenoid valve, then go to Step 8.
5	<b>INSPECT CDCV OPERATION</b> <ul style="list-style-type: none"> <li>Inspect CDCV. (See 01-16-10 CANISTER DRAIN CUT VALVE (CDCV) INSPECTION.)</li> <li>Is CDCV okay?</li> </ul>	Yes	Go to next step.
		No	Replace CDCV, then go to Step 8.
6	<b>INSPECT CHARCOAL CANISTER FOR CLOGGING</b> <ul style="list-style-type: none"> <li>Remove charcoal canister and inspect for clogging. (See 01-16-9 CHARCOAL CANISTER INSPECTION.)</li> <li>Is it okay?</li> </ul>	Yes	Go to next step.
		No	Replace charcoal canister, then go to Step 8.
7	<b>INSPECT FUEL TANK PRESSURE SENSOR</b> <ul style="list-style-type: none"> <li>Inspect fuel tank pressure sensor. (See 01-40A-40 FUEL TANK PRESSURE SENSOR INSPECTION [ZM].)</li> <li>Is it okay?</li> </ul>	Yes	Go to next step.
		No	Replace fuel tank pressure sensor, then go to Step 8.

## ON-BOARD DIAGNOSTIC [ENGINE CONTROL SYSTEM (ZM)]

STEP	INSPECTION	ACTION	
8	<b>VERIFY MONITORING CONDITION FOR EVAPORATIVE SYSTEM TEST</b> <ul style="list-style-type: none"> <li>• Turn ignition key to ON (Engine OFF).</li> <li>• Verify that following conditions are met.                             <ul style="list-style-type: none"> <li>— Engine coolant temperature (at engine start): <b>-10—32.5 °C {14.0—90.5 °F}</b></li> <li>— Barometric pressure: <b>Above 72.2 kPa {542 mmHg, 21.3 inHg}</b></li> <li>— Vehicle: <b>39.5—105.5 km/h {24.5—65.4 mph}</b></li> <li>— Load: <b>9—65%</b></li> <li>— Throttle position: <b>0.15—0.85 %</b></li> <li>— Intake air temperature: <b>-10—60 °C {14—140 °F}</b></li> </ul> </li> <li>• Is there any condition that is out of specification?</li> </ul>	Yes	Take corrective action (e.g. cool down engine), then repeat this step.  <b>Note</b> <ul style="list-style-type: none"> <li>• Readings need to be in the indicated ranges to perform Drive Mode.</li> </ul>
		No	Correct condition, then go to next step.
9	<b>MONITOR EVAP SYSTEM BY DRIVE MODE 4</b> <ul style="list-style-type: none"> <li>• Make sure to reconnect all disconnected connectors.</li> <li>• Clear DTC from memory using WDS or equivalent.</li> <li>• Run OBD-II Drive Mode 4. (See 01-02A-13 Mode 4 (EVAP system repair verification drive mode).)</li> <li>• Stop vehicle and access ON BOARD SYSTEM READINESS TESTS to inspect Drive Mode completion status.</li> <li>• Has EVAPORATIVE PURGE SYSTEM been monitored?</li> </ul>	Yes	Go to next step.
		No	Go back to Step 8.
10	<b>VERIFY TROUBLESHOOTING OF DTC P0451 COMPLETED</b> <ul style="list-style-type: none"> <li>• Turn ignition key to ON (Engine OFF).</li> <li>• Is pending code of same DTC present?</li> </ul>	Yes	Replace PCM, then go to next step.
		No	Go to next step.
11	<b>VERIFY AFTER REPAIR PROCEDURE</b> <ul style="list-style-type: none"> <li>• Perform "After Repair Procedure". (See 01-02A-10 AFTER REPAIR PROCEDURE [ZM].)</li> <li>• Is there any DTC present?</li> </ul>	Yes	Go to applicable DTC inspection. (See 01-02A-15 DTC TABLE [ZM].)
		No	Troubleshooting completed.

### DTC P0452 [ZM]

A3U010201086W22

DTC P0452	Fuel tank pressure sensor circuit low input
<b>DETECTION CONDITION</b>	<ul style="list-style-type: none"> <li>• PCM monitors input voltage from fuel tank pressure sensor when monitoring condition is met. If PCM terminal 62 voltage is <b>below 0.20 V</b> after engine is started, PCM determines that fuel tank pressure sensor circuit is malfunctioning.</li> </ul> <b>MONITORING CONDITION</b> <ul style="list-style-type: none"> <li>— Engine coolant temperature is <b>below 80 °C {176 °F}</b>.</li> </ul> <b>Diagnostic support note</b> <ul style="list-style-type: none"> <li>• This is a continuous CCM monitor (CCM).</li> <li>• MIL illuminates if PCM detects the above malfunction condition in two consecutive drive cycles.</li> <li>• PENDING CODE is available if PCM detects the above malfunction condition during first drive cycle.</li> <li>• FREEZE FRAME DATA is available.</li> <li>• DTC is stored in PCM memory.</li> </ul>
<b>POSSIBLE CAUSE</b>	<ul style="list-style-type: none"> <li>• Fuel tank pressure sensor malfunction</li> <li>• Connector or terminal malfunction</li> <li>• Short to ground in wiring harness between fuel tank pressure sensor terminal B and PCM terminal 62</li> <li>• Open circuit in wiring harness between fuel tank pressure sensor terminal C and PCM terminal 90</li> <li>• PCM malfunction</li> </ul>

# ON-BOARD DIAGNOSTIC [ENGINE CONTROL SYSTEM (ZM)]

01-02A

**DTC P0452 Fuel tank pressure sensor circuit low input**

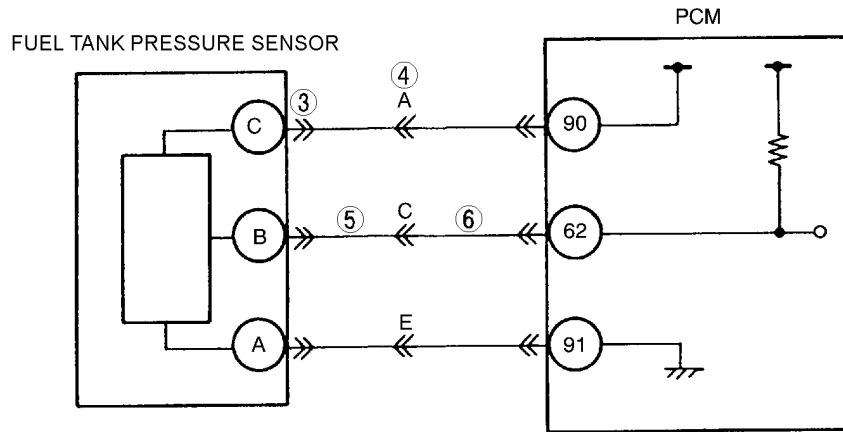

FUEL TANK PRESSURE SENSOR

X-13 CONNECTOR

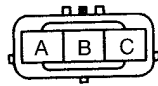

MALE CONNECTOR

FEMALE CONNECTOR

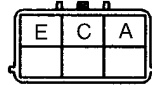

HARNESS SIDE CONNECTOR  
(VIEW FROM TERMINAL SIDE)

HARNESS SIDE CONNECTOR  
(VIEW FROM TERMINAL SIDE)

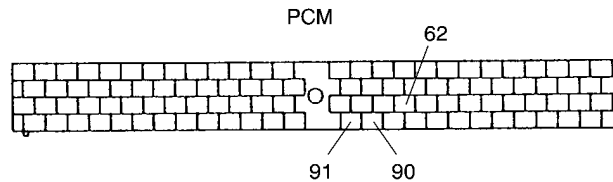

HARNESS SIDE CONNECTOR  
(VIEW FROM HARNESS SIDE)

### Diagnostic procedure

STEP	INSPECTION	ACTION
1	<b>VERIFY FREEZE FRAME DATA HAS BEEN RECORDED</b> • Has FREEZE FRAME DATA been recorded?	Yes Go to next step.
		No Record FREEZE FRAME DATA on repair order, then go to next step.
2	<b>VERIFY RELATED REPAIR INFORMATION AVAILABILITY</b> • Check for related Service Bulletins availability. • Is any related repair information available?	Yes Perform repair or diagnosis according to available repair information. • If vehicle is not repaired, go to next step.
		No Go to next step.
3	<b>CHECK POWER SUPPLY CIRCUIT VOLTAGE AT FUEL TANK PRESSURE SENSOR CONNECTOR</b>  <b>Note</b> • If DTCs P0107 and P0122 are also retrieved with P0452, go to REFERENCE VOLTAGE troubleshooting procedure. (See 01-03A-50 NO.30 CONSTANT VOLTAGE [ZM].)  • Turn ignition key to ON (Engine OFF). • Check voltage between FTP sensor terminal C (harness-side) and body ground. • Is voltage <b>within 4.5—5.5 V</b> ?	Yes Check fuel tank pressure sensor terminal C for poor connection. Repair or replace as necessary. • If okay, replace fuel tank pressure sensor. Then go to Step 7.
		No Go to next step.

## ON-BOARD DIAGNOSTIC [ENGINE CONTROL SYSTEM (ZM)]

STEP	INSPECTION	ACTION	
4	<b>CHECK POWER SUPPLY CIRCUIT VOLTAGE AT FUEL TANK PRESSURE SENSOR INTERMEDIATE CONNECTOR</b> <ul style="list-style-type: none"> <li>• Disconnect X-13 connector.</li> <li>• Measure voltage at X-13 male terminal A.</li> <li>• Is voltage <b>within 4.5—5.5 V</b>?</li> </ul>	Yes	Check for open circuit between following terminals: <ul style="list-style-type: none"> <li>• X-13 connector female terminal A and fuel tank pressure sensor terminal C (harness-side)</li> <li>— Repair or replace suspected harness, then go to Step 7.</li> </ul>
		No	Check for open circuit between following terminals: <ul style="list-style-type: none"> <li>• PCM terminal 90 (harness-side) and X-13 connector male terminal A.</li> <li>— Repair or replace suspected harness, then go to Step 7.</li> </ul>
5	<b>INSPECT FTP SIGNAL CIRCUIT FOR SHORT TO GROUND (FUEL TANK PRESSURE SENSOR CONNECTOR AND X-13 INTERMEDIATE CONNECTOR)</b> <ul style="list-style-type: none"> <li>• Turn ignition key to OFF.</li> <li>• Disconnect X-13 connector.</li> <li>• Check for continuity between X-13 female terminal C and ground.</li> <li>• Is there continuity?</li> </ul>	Yes	Repair or replace suspected harness, then go to Step 7.
		No	Go to next step.
6	<b>INSPECT FTP SIGNAL CIRCUIT FOR SHORT TO GROUND (PCM CONNECTOR AND X-13 INTERMEDIATE CONNECTOR)</b> <ul style="list-style-type: none"> <li>• Disconnect PCM connector.</li> <li>• Check for continuity between X-13 male terminal C (harness-side) and body ground.</li> <li>• Is there continuity?</li> </ul>	Yes	Repair or replace suspected harness, then go to next step.
		No	Check fuel tank pressure sensor signal circuit and fuel tank pressure sensor ground circuit for shorts. Repair or replace suspected harness, then go to next step.
7	<b>VERIFY TROUBLESHOOTING OF DTC P0452 COMPLETED</b> <ul style="list-style-type: none"> <li>• Make sure to reconnect all disconnected connectors.</li> <li>• Turn ignition key to ON (Engine OFF).</li> <li>• Clear DTC from memory using WDS or equivalent.</li> <li>• Start engine.</li> <li>• Is pending code of same DTC present?</li> </ul>	Yes	Replace PCM, then go to next step.
		No	Go to next step.
8	<b>VERIFY AFTER REPAIR PROCEDURE</b> <ul style="list-style-type: none"> <li>• Perform "After Repair Procedure". (See 01-02A-10 AFTER REPAIR PROCEDURE [ZM].)</li> <li>• Is there any DTC present?</li> </ul>	Yes	Go to applicable DTC inspection. (See 01-02A-15 DTC TABLE [ZM].)
		No	Troubleshooting completed.

### DTC P0453 [ZM]

A3U010201086W23

DTC P0453	Fuel tank pressure sensor circuit high input
<b>DETECTION CONDITION</b>	<ul style="list-style-type: none"> <li>• PCM monitors input voltage from FUEL TANK PRESSURE sensor when monitoring condition is met. If PCM terminal voltage is <b>above 4.79 V</b> after engine is started, PCM determines that FUEL TANK PRESSURE sensor circuit has malfunction.</li> </ul> <p><b>MONITORING CONDITION</b></p> <ul style="list-style-type: none"> <li>— Engine coolant temperature is <b>below 80 °C {176 °F}</b>.</li> </ul> <p><b>Diagnostic support note</b></p> <ul style="list-style-type: none"> <li>• This is a continuous monitor (CCM).</li> <li>• MIL illuminates if PCM detects the above malfunction condition in two consecutive drive cycles.</li> <li>• PENDING CODE is available if PCM detects the above detection condition during first drive cycle.</li> <li>• FREEZE FRAME DATA is available.</li> <li>• DTC is stored in PCM memory.</li> </ul>
<b>POSSIBLE CAUSE</b>	<ul style="list-style-type: none"> <li>• FUEL TANK PRESSURE sensor malfunction</li> <li>• Connector or terminal malfunction</li> <li>• Open circuit in wiring between fuel tank pressure sensor terminal B and PCM terminal 62</li> <li>• Open circuit in wiring between from fuel tank pressure sensor terminal A and PCM terminal 91</li> <li>• FUEL TANK PRESSURE sensor signal circuit is shorted to reference voltage (Vref) supply circuit.</li> </ul>

# ON-BOARD DIAGNOSTIC [ENGINE CONTROL SYSTEM (ZM)]

01-02A

**DTC P0453 Fuel tank pressure sensor circuit high input**

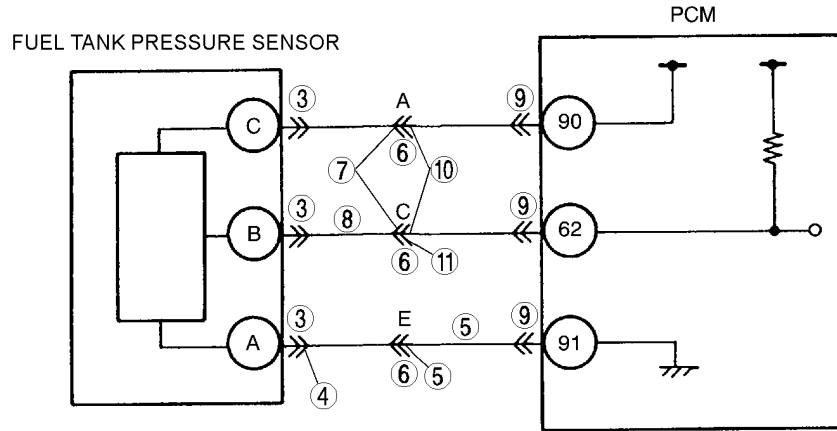

FUEL TANK PRESSURE SENSOR

X-13 CONNECTOR

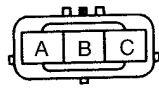

HARNESS SIDE CONNECTOR  
(VIEW FROM TERMINAL SIDE)

MALE CONNECTOR

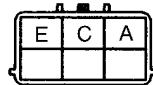

HARNESS SIDE CONNECTOR  
(VIEW FROM TERMINAL SIDE)

FEMALE CONNECTOR



PCM

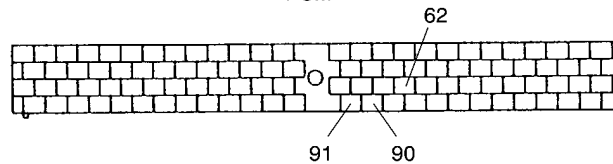

HARNESS SIDE CONNECTOR  
(VIEW FROM HARNESS SIDE)

### Diagnostic procedure

STEP	INSPECTION	ACTION
1	<b>VERIFY FREEZE FRAME DATA HAS BEEN RECORDED</b> <ul style="list-style-type: none"> <li>Has FREEZE FRAME DATA been recorded?</li> </ul>	Yes Go to next step.
		No Record FREEZE FRAME DATA on repair order, then go to next step.
2	<b>VERIFY RELATED REPAIR INFORMATION AVAILABILITY</b> <ul style="list-style-type: none"> <li>Check for related Service Bulletins availability.</li> <li>Is any related repair information available?</li> </ul>	Yes Perform repair or diagnosis according to available repair information. <ul style="list-style-type: none"> <li>If vehicle is not repaired, go to next step.</li> </ul>
		No Go to next step.
3	<b>INSPECT FUEL TANK PRESSURE SENSOR CONNECTOR FOR POOR CONNECTION</b> <ul style="list-style-type: none"> <li>Turn ignition key to OFF.</li> <li>Disconnect FTP sensor connector.</li> <li>Check for poor connection (damaged/pulled-out terminals, corrosion, etc.).</li> <li>Is there malfunction?</li> </ul>	Yes Repair or replace suspected terminal, then go to Step 12.
		No Go to next step.
4	<b>INSPECT FUEL TANK PRESSURE SENSOR GROUND CIRCUIT FOR OPEN CIRCUIT (AT FUEL TANK PRESSURE SENSOR CONNECTOR)</b> <ul style="list-style-type: none"> <li>Check for continuity between fuel tank pressure sensor terminal A (harness-side) and body ground.</li> <li>Is there continuity?</li> </ul>	Yes Go to Step 6.
		No Go to next step.

## ON-BOARD DIAGNOSTIC [ENGINE CONTROL SYSTEM (ZM)]

STEP	INSPECTION	ACTION
5	<b>INSPECT FUEL TANK PRESSURE SENSOR GROUND CIRCUIT FOR OPEN CIRCUIT (AT X-13 CONNECTOR)</b> <ul style="list-style-type: none"> <li>• Disconnect X-13 connector.</li> <li>• Check for continuity between X-13 male terminal E and body ground.</li> <li>• Is there continuity?</li> </ul>	Yes Check for open circuit between following terminals: <ul style="list-style-type: none"> <li>• X-13 female terminal E and FTP sensor terminal A (harness-side)</li> </ul> Repair or replace suspected harness, then go to Step 12.
		No Check for open circuit between following terminals: <ul style="list-style-type: none"> <li>• PCM terminal 91 (harness-side) and X-13 male terminal E</li> </ul> Repair or replace suspected harness, then go to Step 12.
6	<b>CHECK 6-PIN INTERMEDIATE CONNECTOR</b> <ul style="list-style-type: none"> <li>• Disconnect X-13 connector.</li> <li>• Check for poor connection (damaged/pulled-out pins, corrosion, etc.).</li> <li>• Is there malfunction?</li> </ul>	Yes Repair or replace suspected terminal, then go to Step 12.
		No Go to next step.
7	<b>INSPECT FUEL TANK PRESSURE SIGNAL CIRCUIT FOR SHORT TO CONSTANT VOLTAGE CIRCUIT (FUEL TANK PRESSURE SENSOR CONNECTOR AND X-13 CONNECTOR)</b> <ul style="list-style-type: none"> <li>• Check for continuity between X-13 female terminals A and C.</li> <li>• Is there continuity?</li> </ul>	Yes Repair or replace suspected harness, then go to Step 12.
		No Go to next step.
8	<b>INSPECT FUEL TANK PRESSURE SIGNAL CIRCUIT FOR OPEN CIRCUIT (FUEL TANK PRESSURE SENSOR CONNECTOR AND X-13 CONNECTOR)</b> <ul style="list-style-type: none"> <li>• Check for continuity between fuel tank pressure sensor terminal B (harness-side) and X-13 female terminal C.</li> <li>• Is there continuity?</li> </ul>	Yes Go to next step.
		No Repair or replace suspected harness, then go to Step 12.
9	<b>INSPECT PCM CONNECTOR FOR POOR CONNECTION</b> <ul style="list-style-type: none"> <li>• Disconnect PCM connector.</li> <li>• Check for poor connection at terminals 62, 90 and 91 (damaged/pulled-out terminals, corrosion, etc.).</li> <li>• Is there malfunction?</li> </ul>	Yes Repair terminal, then go to Step 12.
		No Go to next step.
10	<b>INSPECT FUEL TANK PRESSURE SIGNAL CIRCUIT FOR SHORT TO CONSTANT VOLTAGE CIRCUIT (X-13 CONNECTOR AND PCM CONNECTOR)</b> <ul style="list-style-type: none"> <li>• Check for continuity between X-13 terminals A and C (PCM-side).</li> <li>• Is there continuity?</li> </ul>	Yes Repair or replace suspected harness, then go to Step 12.
		No Go to next step.
11	<b>INSPECT FUEL TANK PRESSURE SIGNAL CIRCUIT FOR OPEN CIRCUIT (X-13 CONNECTOR AND PCM CONNECTOR)</b> <ul style="list-style-type: none"> <li>• Connect breakout box with PCM disconnected.</li> <li>• Check for continuity between X-13 male terminal C (PCM-side) and breakout box terminal 62.</li> <li>• Is there continuity?</li> </ul>	Yes Go to next step.
		No Repair or replace suspected harness, then go to next step.
12	<b>VERIFY TROUBLESHOOTING OF DTC P0453 COMPLETED</b> <ul style="list-style-type: none"> <li>• Make sure to reconnect all disconnected connectors.</li> <li>• Turn ignition key ON (Engine OFF).</li> <li>• Clear DTC from memory using WDS or equivalent.</li> <li>• Start engine.</li> <li>• Is pending code of same DTC present?</li> </ul>	Yes Replace PCM, then go to next step.
		No Go to next step.
13	<b>VERIFY AFTER REPAIR PROCEDURE</b> <ul style="list-style-type: none"> <li>• Perform "After Repair Procedure". (See 01-02A-10 AFTER REPAIR PROCEDURE [ZM].)</li> <li>• Is there any DTC present?</li> </ul>	Yes Go to applicable DTC inspection. (See 01-02A-15 DTC TABLE [ZM].)
		No Troubleshooting completed.



# ON-BOARD DIAGNOSTIC [ENGINE CONTROL SYSTEM (ZM)]

DTC P0455 [ZM]

A3U010201086W24

01-02A

DTC P0455	Evaporative emission control system leak detected (blockage or large leak)
<b>DETECTION CONDITION</b>	<ul style="list-style-type: none"> <li>PCM measures the fuel tank pressure (ftp1), which is the vacuum when a specified period has passed after the tank pressure has reached the preprogrammed target pressure and purge control valve has been closed when monitoring conditions are met. If fuel tank pressure is above threshold, PCM determines that the EVAP system is blocked or has a large leak.</li> </ul> <p><b>THRESHOLD VALUE</b></p> <ul style="list-style-type: none"> <li>— Fuel tank pressure (ftp1): <b>-1.3—1.95 kPa {-9.76—14.65 mmHg, -0.38—0.58 inHg}</b> <ul style="list-style-type: none"> <li>Threshold valve varies depends on ECT at engine start BARO.</li> </ul> </li> </ul> <p><b>MONITORING CONDITIONS</b></p> <ul style="list-style-type: none"> <li>— Fuel tank pressure (ftp 1): <b>-3.92 kPa {-29.4 mmHg, -1.16 inHg}</b></li> <li>— PCM monitors EVAP system when driving under following conditions:                             <ul style="list-style-type: none"> <li>Remaining fuel: <b>15—85%</b></li> <li>ECT at engine start: <b>-10—32.5 °C {14.0—90.5 °F}</b></li> <li>Atmospheric pressure: <b>above 72.2 kPa {542 mmHg, 21.3 inHg}</b></li> <li>Vehicle speed: <b>39.5—120.3 km/h {24.5—74.7 mph}</b></li> <li>Engine speed: <b>1,000—4,000 rpm</b></li> <li>Calculated load: <b>9—65%</b></li> <li>Throttle opening angle: <b>3.1—12.5%</b></li> <li>IAT during monitor: <b>-10—60 °C {14—140 °F}</b></li> </ul> </li> </ul> <p><b>Diagnostic support note</b></p> <ul style="list-style-type: none"> <li>This is an intermittent monitor (Evaporative leak monitor).</li> <li>MIL illuminates if PCM detects the above malfunction condition in two consecutive drive cycles.</li> <li>DIAGNOSTIC MONITORING TEST RESULTS and PENDING CODE are available if PCM detects the above malfunction condition during first drive cycle.</li> <li>FREEZE FRAME DATA is available.</li> <li>DTC is stored in PCM memory.</li> </ul>
<b>POSSIBLE CAUSE</b>	<ul style="list-style-type: none"> <li>Purge solenoid valve malfunction</li> <li>Canister drain cut valve (CDCV) malfunction</li> <li>Loose, missing or defective fuel filler cap</li> <li>Charcoal canister malfunction</li> <li>Catch tank malfunction</li> <li>Check valve malfunction</li> <li>Rollover valve malfunction</li> <li>Cracked fuel tank</li> <li>Fuel tank component parts poorly installed</li> <li>EVAP hose damaged or loose</li> <li>Fuel tank pressure sensor malfunction</li> </ul>

**Diagnostic procedure**

STEP	INSPECTION		ACTION
1	<b>VERIFY FREEZE FRAME DATA HAS BEEN RECORDED</b> <ul style="list-style-type: none"> <li>Has FREEZE FRAME DATA been recorded?</li> </ul>	Yes	Go to next step.
		No	Record FREEZE FRAME DATA on repair order, then go to next step.
2	<b>VERIFY RELATED REPAIR INFORMATION AVAILABILITY</b> <ul style="list-style-type: none"> <li>Check for related Service Bulletins availability.</li> <li>Is any related repair information available?</li> </ul>	Yes	Perform repair or diagnosis according to available repair information. <ul style="list-style-type: none"> <li>If vehicle is not repaired, go to next step.</li> </ul>
		No	Go to next step.
3	<b>VERIFY RELATED PENDING CODE OR STORED DTCS</b> <ul style="list-style-type: none"> <li>Turn ignition key to OFF then ON (Engine OFF).</li> <li>Verify related PENDING CODE or stored DTCS.</li> <li>DTCS P0443 and/or P1449 present?</li> </ul>	Yes	Go to appropriate DTC inspection.
		No	Go to next step.
4	<b>INSPECT FUEL-FILLER CAP</b> <ul style="list-style-type: none"> <li>Verify fuel-filler cap is neither disconnected loose nor damaged.</li> <li>Is it okay?</li> </ul> <p><b>Note</b></p> <ul style="list-style-type: none"> <li>When fuel-filler caps other than OEM caps are attached, it is considered malfunction.</li> </ul>	Yes	Go to next step.
		No	Retighten fuel-filler cap or replace it if it is damaged. Then go to Step 27.

## ON-BOARD DIAGNOSTIC [ENGINE CONTROL SYSTEM (ZM)]

STEP	INSPECTION	ACTION	
5	<b>INSPECT PURGE SOLENOID VALVE FOR STUCKING</b> <ul style="list-style-type: none"> <li>• Inspect purge solenoid valve (See 01-16-12 PURGE SOLENOID VALVE INSPECTION.)</li> <li>• Is purge solenoid valve okay?</li> </ul>	Yes	Go to next step.
		No	Replace purge solenoid valve, then go to Step 27.
6	<b>INSPECT CDCV FOR STUCKING</b> <ul style="list-style-type: none"> <li>• Inspect CDCV. (See 01-16-10 CANISTER DRAIN CUT VALVE (CDCV) INSPECTION.)</li> <li>• Is CDCV okay?</li> </ul>	Yes	Go to next step.
		No	Replace CDCV, then go to Step 27.
7	<b>CLASSIFY EVAPORATIVE EMISSION CONTROL SYSTEM FOR LEAKAGE OR BLOCKAGE</b> <p><b>Note</b></p> <ul style="list-style-type: none"> <li>• If evaporative emission tester is not available, go to next step.</li> <li>• Carry out evaporative emission control system inspection using evaporative emission tester. (See 01-03A-55 Evaporative System Leak Inspection Using Leak Tester.)</li> <li>• Does red "FAILED" light turn ON (leakage)?</li> </ul>	Yes	Tester detects leakage. <ul style="list-style-type: none"> <li>• Inspect evaporative control system for leakage using evaporative emission tester. (See 01-03A-55 Evaporative System Leak Inspection Using Leak Tester.)</li> <li>• Repair or replace faulty area, then go to Step 27.</li> </ul>
		No	Go to next step.
8	<b>VERIFY REPAIR SHOP CONDITION</b> <ul style="list-style-type: none"> <li>• Is repair shop possible to perform Drive Mode 4?</li> </ul>	Yes	Go to next step.
		No	Go to Step 16.
9	<b>VERIFY MONITORING CONDITION FOR DRIVE MODE 4</b> <ul style="list-style-type: none"> <li>• Turn ignition key to ON (Engine OFF).</li> <li>• Verify that following conditions are met.                             <ul style="list-style-type: none"> <li>— Barometric pressure: <b>72.2 kPa {542 mmHg, 21.3 inHg} or higher</b></li> <li>— Engine coolant temperature: <b>-10.0—22.0 °C {14.0—72.0 °F}</b> [at barometric pressure <b>72.2 kPa {542 mmHg, 21.3 inHg}</b>]</li> <li>— Intake air temperature: <b>-10—60 °C {50—140 °F}</b></li> <li>— Fuel tank level: <b>15—85%</b></li> </ul> </li> <li>• Is there any conditions that is out of specification?</li> </ul>	Yes	Take corrective action (e.g. cool down engine), then repeat this step. <p style="text-align: center;"><b>Note</b></p> <ul style="list-style-type: none"> <li>• Readings need to be in the indicated ranges to perform Drive Mode.</li> </ul>
		No	Go to next step.
10	<b>MONITOR EVAP SYSTEM BY DRIVE MODE 4</b> <ul style="list-style-type: none"> <li>• Clear DTC from memory using WDS or equivalent.</li> <li>• Run OBD-II Drive Mode 4 and verify that CDCV and FTP graphs. (See 01-02A-13 Mode 4 (EVAP system repair verification drive mode).)</li> <li>• Is there any problem detected?</li> </ul>	Yes	FTP does not change: <ul style="list-style-type: none"> <li>• EVAP monitoring system is inoperative. Go to next step.</li> </ul> FTP changes, but does not reach <b>2.0 kPa {15 mmHg, 0.59 inHg}</b> : <ul style="list-style-type: none"> <li>• There is a large leak in EVAP system. Go to Step 13.</li> </ul> FTP reaches <b>2.0 kPa {15 mmHg, 0.59 inHg}</b> , but suddenly goes back: <ul style="list-style-type: none"> <li>• Pressure in fuel tank cannot be reduced and only gas from EVAP line can be drawn.</li> </ul> Inspect following and repair or replace suspected parts. <ul style="list-style-type: none"> <li>• Rollover valve for large ventilation resistance.</li> <li>• Check valve for inoperative or blockage.</li> <li>• Air filter for clogging.</li> </ul> Then go to Step 27.
		No	No leaks were detected in EVAP control system at this time. Go to Step 30.
11	<b>INSPECT PURGE SOLENOID VALVE OPERATION</b> <ul style="list-style-type: none"> <li>• Inspect purge solenoid valve (See 01-16-12 PURGE SOLENOID VALVE INSPECTION.)</li> <li>• Is purge solenoid valve okay?</li> </ul>	Yes	Go to next step.
		No	Replace purge solenoid valve, then go to Step 27.

## ON-BOARD DIAGNOSTIC [ENGINE CONTROL SYSTEM (ZM)]

STEP	INSPECTION	ACTION	
12	<b>INSPECT FUEL TANK PRESSURE SENSOR</b> <ul style="list-style-type: none"> <li>• Inspect fuel tank pressure sensor. (See 01-40A-40 FUEL TANK PRESSURE SENSOR INSPECTION [ZM].)</li> <li>• Is fuel tank pressure sensor okay?</li> </ul>	Yes	Go to next step.
		No	Replace fuel tank pressure sensor, then go to Step 27.
13	<b>INSPECT CATCH TANK</b> <ul style="list-style-type: none"> <li>• Remove catch tank and inspect for plugging, damages and pinhole using vacuum pump.</li> <li>• Is it okay?</li> </ul>	Yes	Go to next step.
		No	Replace catch tank, then go to Step 27.
14	<b>INSPECT CHARCOAL CANISTER</b> <ul style="list-style-type: none"> <li>• Remove charcoal canister and inspect for damage and pinhole.</li> <li>• Is it okay?</li> </ul>	Yes	Go to next step.
		No	Replace charcoal canister, then go to Step 27.
15	<b>INSPECT CDCV OPERATION</b> <ul style="list-style-type: none"> <li>• Inspect CDCV. (See 01-16-10 CANISTER DRAIN CUT VALVE (CDCV) INSPECTION.)</li> <li>• Is CDCV okay?</li> </ul>	Yes	Go to next step.
		No	Replace CDCV, then go to Step 27.
16	<b>INSPECT WHOLE SYSTEM OF EVAP CONTROL SYSTEM</b> <ul style="list-style-type: none"> <li>• Implement "01-03A ENGINE CONTROL SYSTEM OPERATION INSPECTION [ZM], Evaporative System Leak Inspection Using Vacuum Pump, Whole system inspection". (See 01-03A-56 Whole system inspection.)</li> <li>• Does voltage change under to specified readings and hold for <b>minimum of 2 minutes</b>?</li> </ul>	Yes	Intermittent concern exists. (See 01-03A-4 INTERMITTENT CONCERN TROUBLESHOOTING [ZM].) Inspect purge solenoid valve and CDCV circuit.
		No	Go to next step.
17	<b>INSPECT FUEL TANK PRESSURE SENSOR</b> <ul style="list-style-type: none"> <li>• Inspect fuel tank pressure sensor. (See 01-40A-40 FUEL TANK PRESSURE SENSOR INSPECTION [ZM].)</li> <li>• Is fuel tank pressure sensor okay?</li> </ul>	Yes	Go to next step.
		No	Replace fuel tank pressure sensor, then go to Step 27.
18	<b>INSPECT LEAKAGE FROM CHARCOAL CANISTER TO FUEL TANK</b> <ul style="list-style-type: none"> <li>• Implement "01-03A ENGINE CONTROL OPERATION INSPECTION [ZM], Evaporative System Leak Inspection Using Vacuum Pump, Inspection from charcoal canister to fuel tank". (See 01-03A-56 Inspection from charcoal canister to fuel tank.)</li> <li>• Does voltage change under to specified readings and hold for <b>minimum of 2 minutes</b>?</li> </ul>	Yes	Go to Step 22.
		No	Go to next step.
19	<b>INSPECT ATTACHED ACCESSORIES ON FUEL TANK</b> <ul style="list-style-type: none"> <li>• Remove fuel tank and visually inspect for damage, insufficient sealing or poorly attached accessories on fuel tank, such as fuel gauge.</li> <li>• Is it okay?</li> </ul>	Yes	Go to next step.
		No	Repair or replace fuel tank or sealing, then go to Step 27.
20	<b>INSPECT FUEL SHUT-OFF VALVE</b> <ul style="list-style-type: none"> <li>• Inspect fuel shut-off valve for ventilation. (See 01-14-13 FUEL TANK INSPECTION.)</li> <li>• Is it okay?</li> </ul>	Yes	Go to next step.
		No	Replace fuel tank, then go to Step 27.
21	<b>INSPECT ROLLOVER VALVE</b> <ul style="list-style-type: none"> <li>• Inspect rollover valve for ventilation.</li> <li>• Is it okay?</li> </ul>	Yes	Inspect following and repair or replace for detached, incorrectly installed or cracked hoses: <ul style="list-style-type: none"> <li>• Charcoal canister</li> <li>• Fuel tank (include fuel shut-off valve and rollover valve)</li> <li>• Fuel tank pressure sensor</li> </ul> Then go to Step 27.
		No	Replace fuel tank, then go to Step 27.

01-02A

## ON-BOARD DIAGNOSTIC [ENGINE CONTROL SYSTEM (ZM)]

STEP	INSPECTION	ACTION	
22	<b>INSPECT LEAKAGE FROM CHARCOAL CANISTER TO PURGE SOLENOID VALVE</b> <ul style="list-style-type: none"> <li>• Implement “01-03A ENGINE CONTROL SYSTEM OPERATION INSPECTION [ZM], Evaporative Leak System Inspection Using Vacuum Pump, Inspection from charcoal canister to purge solenoid valve”. (See 01-03A-56 Inspection from charcoal canister to purge solenoid valve.)</li> <li>• Does voltage change under to specified readings and hold for a <b>minimum of 2 minutes</b>?</li> </ul>	Yes	Go to Step 27.
		No	Go to next step.
23	<b>INSPECT CATCH TANK</b> <ul style="list-style-type: none"> <li>• Remove catch tank and inspect for plugging, damages and pinhole using vacuum pump.</li> <li>• Is it okay?</li> </ul>	Yes	Go to next step.
		No	Replace catch tank, then go to Step 27.
24	<b>INSPECT PURGE SOLENOID VALVE OPERATION</b> <ul style="list-style-type: none"> <li>• Inspect purge solenoid valve (See 01-16-12 PURGE SOLENOID VALVE INSPECTION.)</li> <li>• Is purge solenoid valve okay?</li> </ul>	Yes	Go to next step.
		No	Replace purge solenoid valve, then go to Step 27.
25	<b>INSPECT CHARCOAL CANISTER</b> <ul style="list-style-type: none"> <li>• Remove charcoal canister and inspect for plugging, damage and pinhole.</li> <li>• Is it okay?</li> </ul>	Yes	Go to next step.
		No	Replace charcoal canister, then go to Step 27.
26	<b>INSPECT CDCV OPERATION</b> <ul style="list-style-type: none"> <li>• Inspect CDCV. (See 01-16-10 CANISTER DRAIN CUT VALVE (CDCV) INSPECTION.)</li> <li>• Is CDCV okay?</li> </ul>	Yes	Go to next step.
		No	Replace CDCV, then go to next step.
27	<b>DECIDE ON AFTER REPAIR PROCEDURE ACCORDING TO REPAIR SHOP CONDITION</b> <ul style="list-style-type: none"> <li>• Clear DTC from memory using WDS or equivalent.</li> <li>• Is repair shop possible to perform Drive Mode 4?</li> </ul>	Yes	Go to next step.
		No	Go to step 31.
28	<b>VERIFY MONITORING CONDITION FOR EVAPORATIVE SYSTEM TEST OR DRIVE MODE 4</b> <ul style="list-style-type: none"> <li>• Turn ignition key to ON (Engine OFF).</li> <li>• Verify that following conditions are met. <ul style="list-style-type: none"> <li>— Barometric pressure: <b>72.2 kPa {542 mmHg, 21.3 inHg} or higher</b></li> <li>— Engine coolant temperature: <b>-10.0—22.0 °C {14.0—72.0 °F}</b> [at barometric pressure <b>72.2 kPa {542 mmHg, 21.3 inHg}</b>]</li> <li>— Intake air temperature: <b>10—60 °C {50—140 °F}</b></li> <li>— Fuel tank level: <b>15—85%</b></li> </ul> </li> <li>• Is there any conditions that is out of specification?</li> </ul>	Yes	Take corrective action (e.g. cool down engine), then repeat this step.  <b>Note</b> <ul style="list-style-type: none"> <li>• Readings need to be in the indicated ranges to perform Drive Mode.</li> </ul>
		No	Go to next step.
29	<b>MONITOR EVAP SYSTEM BY DRIVE MODE 4</b> <ul style="list-style-type: none"> <li>• Run OBD-II Drive Mode 4. (See 01-02A-13 Mode 4 (EVAP system repair verification drive mode).)</li> <li>• Stop vehicle and access ON BOARD SYSTEM READINESS TESTS to inspect Drive Mode completion status.</li> <li>• Has EVAPORATIVE PURGE SYSTEM been monitored?</li> </ul>	Yes	Go to next step.
		No	Go back to Step 28.

## ON-BOARD DIAGNOSTIC [ENGINE CONTROL SYSTEM (ZM)]

STEP	INSPECTION	ACTION
30	<b>VERIFY EVAP SYSTEM REPAIRED</b> <ul style="list-style-type: none"> <li>Access DIAGNOSTIC MONITORING TEST RESULTS.</li> <li>Verify TEST ID 10:22:00 value. (See 01-02A-10 Diagnostic Monitoring Test Results Access Procedure.)</li> <li>Is it below maximum value?</li> </ul>	Yes Go to Step 32.
		No Replace PCM, then go to Step 32.
31	<b>INSPECT WHOLE EVAP CONTROL SYSTEM</b> <ul style="list-style-type: none"> <li>Implement "01-03A ENGINE CONTROL SYSTEM OPERATION INSPECTION [ZM], Evaporative System Leak Inspection Using Vacuum Pump, Whole system inspection". (See 01-03A-56 Whole system inspection.)</li> <li>Does voltage change under to specified readings and hold for <b>minimum of 2 minutes</b>?</li> </ul>	Yes Go to Step 32.
		No Replace PCM, then go to Step 32.
32	<b>VERIFY AFTER REPAIR PROCEDURE</b> <ul style="list-style-type: none"> <li>Perform "After Repair Procedure". (See 01-02A-10 AFTER REPAIR PROCEDURE [ZM].)</li> <li>Is there any DTC present?</li> </ul>	Yes Go to applicable DTC inspection. (See 01-02A-15 DTC TABLE [ZM].)
		No Troubleshooting completed.

01-02A

### DTC P0461 [ZM]

A3U010201086W25

DTC P0461	Fuel gauge sender unit circuit range/performance
<b>DETECTION CONDITION</b>	<ul style="list-style-type: none"> <li>PCM monitors fuel gauge sender unit input voltage difference before and after PCM-calculated fuel consumption has reached <b>17.5 liters {18.5 US qt., 15.4 Imp qt.}</b>. If fuel gauge sender unit operation reflects <b>5% less</b> than PCM-calculated fuel consumption, PCM determines that fuel gauge sender unit range/performance is in error.</li> </ul> <p><b>Diagnostic support note</b></p> <ul style="list-style-type: none"> <li>This is a continuous monitor (CCM).</li> <li>MIL illuminates if PCM detects the above malfunction condition in two consecutive drive cycles.</li> <li>PENDING CODE is available if PCM detects the above malfunction condition during first drive cycle.</li> <li>FREEZE FRAME DATA is available.</li> <li>DTC is stored in PCM memory.</li> </ul>
<b>POSSIBLE CAUSE</b>	<ul style="list-style-type: none"> <li>Fuel gauge sender unit malfunction or substandard performance</li> </ul>

### Diagnostic procedure

STEP	INSPECTION	ACTION
1	<b>VERIFY FREEZE FRAME DATA HAS BEEN RECORDED</b> <ul style="list-style-type: none"> <li>Has FREEZE FRAME DATA been recorded?</li> </ul>	Yes Go to next step.
		No Record FREEZE FRAME DATA on repair order, then go to next step.
2	<b>VERIFY RELATED REPAIR INFORMATION AVAILABILITY</b> <ul style="list-style-type: none"> <li>Check for related Service Bulletins availability.</li> <li>Is any related repair information available?</li> </ul>	Yes Perform repair or diagnosis according to available repair information. <ul style="list-style-type: none"> <li>If vehicle is not repaired, go to next step.</li> </ul>
		No Go to next step.
3	<b>INSPECT FUEL GAUGE SENDER UNIT</b> <ul style="list-style-type: none"> <li>Turn ignition key to OFF.</li> <li>Inspect fuel gauge sender unit. (See 09-22-13 FUEL GAUGE SENDER UNIT INSPECTION.)</li> <li>Is fuel gauge sender unit okay?</li> </ul>	Yes Replace PCM, then go to next step.
		No Repair or replace fuel gauge sender unit, then go to next step.
4	<b>VERIFY AFTER REPAIR PROCEDURE</b> <ul style="list-style-type: none"> <li>Perform "After Repair Procedure". (See 01-02A-10 AFTER REPAIR PROCEDURE [ZM].)</li> <li>Is there any DTC present?</li> </ul>	Yes Go to applicable DTC inspection. (See 01-02A-15 DTC TABLE [ZM].)
		No Troubleshooting completed.

# ON-BOARD DIAGNOSTIC [ENGINE CONTROL SYSTEM (ZM)]

DTC P0462 [ZM]

A3U010201086W26

<b>DTC P0462</b>	<b>Fuel gauge sender unit circuit low input</b>
<b>DETECTION CONDITION</b>	<ul style="list-style-type: none"> <li>PCM monitors the voltage of fuel gauge sender unit. If PCM detects PCM terminal 63 voltage <b>below 0.08 V</b> for <b>5 seconds</b>, PCM determines that fuel gauge sender unit circuit has a malfunction.</li> </ul> <p><b>Diagnostic support note</b></p> <ul style="list-style-type: none"> <li>This is a continuous monitor (CCM).</li> <li>MIL illuminates if PCM detects the above malfunction condition in two consecutive drive cycles.</li> <li>PENDING CODE is available if PCM detects the above malfunction condition during first drive cycle.</li> <li>FREEZE FRAME DATA is available.</li> <li>DTC is stored in PCM memory.</li> </ul>
<b>POSSIBLE CAUSE</b>	<ul style="list-style-type: none"> <li>Fuel gauge sender unit malfunction</li> <li>Short to ground circuit between fuel gauge sender unit terminal A and PCM terminal 63</li> <li>Short circuit between fuel level signal circuit and fuel gauge sender unit ground circuit</li> <li>PCM malfunction</li> <li>Bent terminals of fuel gauge sender unit</li> </ul>

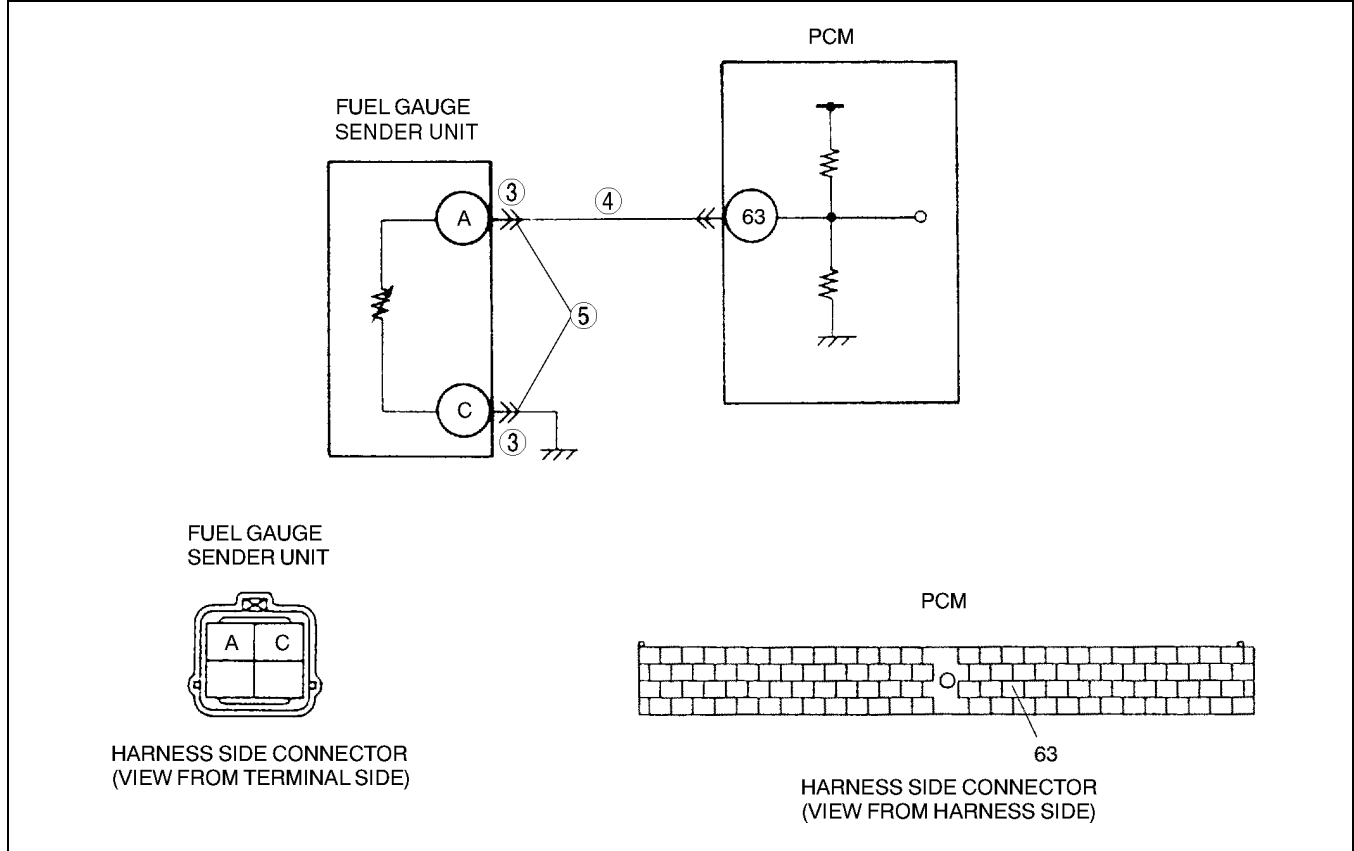

**Diagnostic procedure**

STEP	INSPECTION		ACTION
1	<b>VERIFY FREEZE FRAME DATA HAS BEEN RECORDED</b> <ul style="list-style-type: none"> <li>Has FREEZE FRAME DATA been recorded?</li> </ul>	Yes	Go to next step.
		No	Record FREEZE FRAME DATA on repair order, then go to next step.
2	<b>VERIFY RELATED REPAIR INFORMATION AVAILABILITY</b> <ul style="list-style-type: none"> <li>Check for related Service Bulletins availability.</li> <li>Is any related repair information available?</li> </ul>	Yes	Perform repair or diagnosis according to available repair information. <ul style="list-style-type: none"> <li>If vehicle is not repaired, go to next step.</li> </ul>
		No	Go to next step.
3	<b>INSPECT TERMINAL FOR BENT</b> <ul style="list-style-type: none"> <li>Turn ignition key to OFF.</li> <li>Disconnect fuel gauge sender unit connector.</li> <li>Check for bent terminal.</li> <li>Is there malfunction?</li> </ul>	Yes	Repair suspected terminal, then go to Step 6.
		No	Go to next step.

## ON-BOARD DIAGNOSTIC [ENGINE CONTROL SYSTEM (ZM)]

STEP	INSPECTION	ACTION	
4	<b>INSPECT FUEL LEVEL SIGNAL CIRCUIT FOR SHORT TO GROUND</b> <ul style="list-style-type: none"> <li>• Turn ignition key to OFF.</li> <li>• Disconnect PCM connector.</li> <li>• Check for continuity between fuel gauge sender unit terminal A (harness-side) and body GND.</li> <li>• Is there continuity?</li> </ul>	Yes	Repair or replace suspected harness, then go to Step 6.
		No	Go to next step.
5	<b>INSPECT FUEL GAUGE SENDER UNIT CIRCUITS FOR SHORTS</b> <ul style="list-style-type: none"> <li>• Check for continuity between fuel gauge sender unit terminals A and C (harness-side).</li> <li>• Is there continuity?</li> </ul>	Yes	Repair or replace suspected harness, then go to Step 6.
		No	Go to next step.
6	<b>VERIFY TROUBLESHOOTING OF DTC P0462 COMPLETED</b> <ul style="list-style-type: none"> <li>• Make sure to reconnect all disconnected connectors.</li> <li>• Turn ignition key to ON (Engine OFF).</li> <li>• Clear DTC from memory using WDS or equivalent.</li> <li>• Start engine.</li> <li>• Is pending code of same DTC present?</li> </ul>	Yes	Replace PCM, then go to next step.
		No	Go to next step.
7	<b>VERIFY AFTER REPAIR PROCEDURE</b> <ul style="list-style-type: none"> <li>• Perform "After Repair Procedure". (See 01-02A-10 AFTER REPAIR PROCEDURE [ZM].)</li> <li>• Is there any DTC present?</li> </ul>	Yes	Go to applicable DTC inspection. (See 01-02A-15 DTC TABLE [ZM].)
		No	Troubleshooting completed.

01-02A

# ON-BOARD DIAGNOSTIC [ENGINE CONTROL SYSTEM (ZM)]

**DTC P0463 [ZM]**

A3U010201086W27

<b>DTC P0463</b>	<b>Fuel gauge sender unit circuit high input</b>
<b>DETECTION CONDITION</b>	<ul style="list-style-type: none"> <li>PCM monitors the voltage of fuel gauge sender unit. If PCM detects PCM terminal 63 voltage <b>above 4.92 V</b> for <b>5 seconds</b>, PCM determines that fuel gauge sender unit circuit has a malfunction.</li> </ul> <p><b>Diagnostic support note</b></p> <ul style="list-style-type: none"> <li>This is a continuous monitor (CCM).</li> <li>MIL illuminates if PCM detects the above malfunction condition in two consecutive drive cycles.</li> <li>PENDING CODE is available if PCM detects the above malfunction condition during first drive cycle.</li> <li>FREEZE FRAME DATA is available.</li> <li>DTC is stored in PCM memory.</li> </ul>
<b>POSSIBLE CAUSE</b>	<ul style="list-style-type: none"> <li>Fuel gauge sender unit malfunction</li> <li>Open circuit between fuel gauge sender unit terminal A and PCM terminal 63.</li> <li>Open circuit between fuel gauge sender unit terminal C and body ground.</li> <li>Poor connection of fuel gauge sender unit and/or PCM connector</li> <li>PCM malfunction</li> </ul>

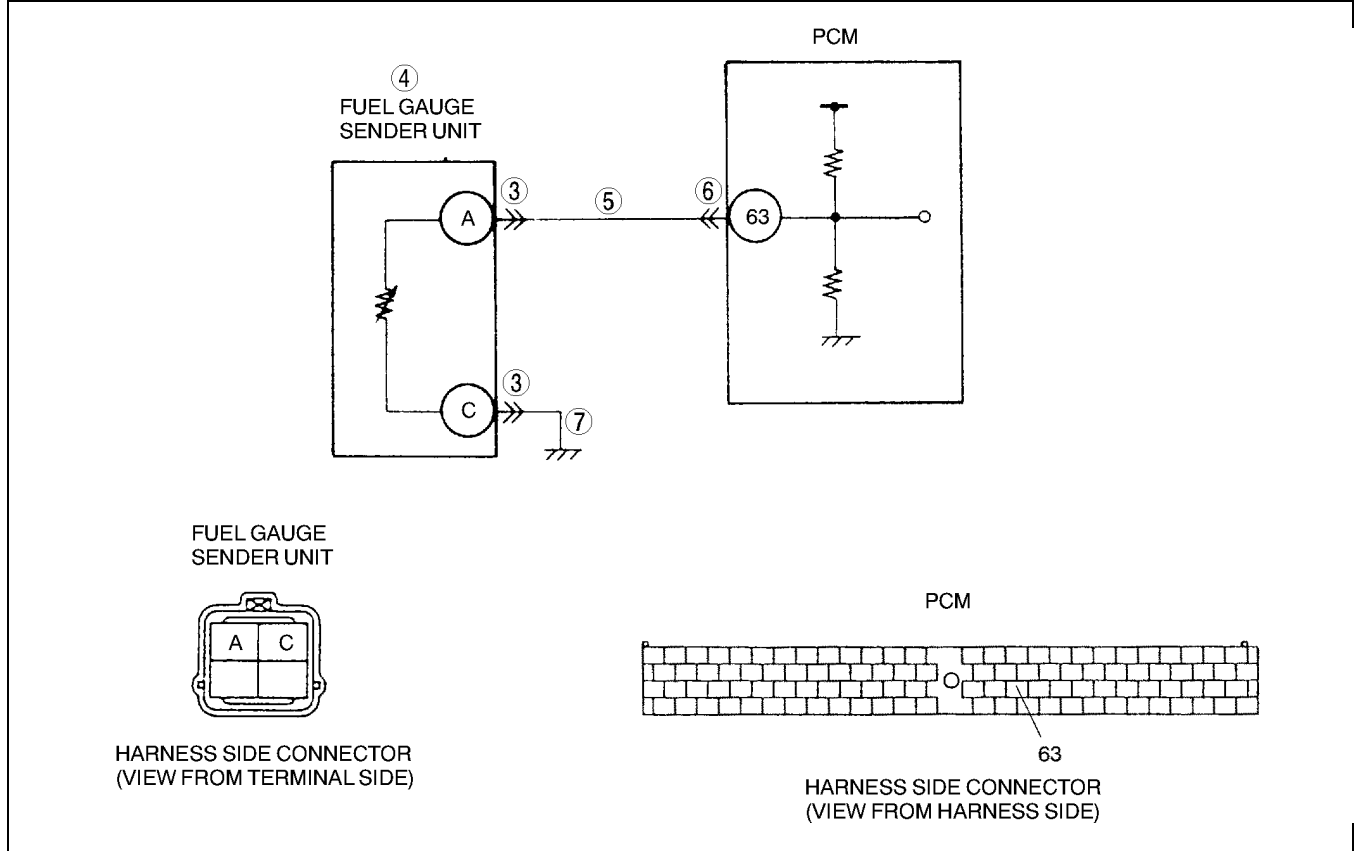

**Diagnostic procedure**

STEP	INSPECTION		ACTION
1	<b>VERIFY FREEZE FRAME DATA HAS BEEN RECORDED</b> <ul style="list-style-type: none"> <li>Has FREEZE FRAME DATA been recorded?</li> </ul>	Yes	Go to next step.
		No	Record FREEZE FRAME DATA on repair order, then go to next step.
2	<b>VERIFY RELATED REPAIR INFORMATION AVAILABILITY</b> <ul style="list-style-type: none"> <li>Check for related Service Bulletins availability.</li> <li>Is any related repair information available?</li> </ul>	Yes	Perform repair or diagnosis according to available repair information. <ul style="list-style-type: none"> <li>If vehicle is not repaired, go to next step.</li> </ul>
		No	Go to next step.
3	<b>INSPECT FUEL GAUGE SENDER UNIT CONNECTOR FOR POOR CONNECTION</b> <ul style="list-style-type: none"> <li>Turn ignition key to OFF.</li> <li>Disconnect fuel gauge sender unit connector.</li> <li>Check for poor connection (damaged/pulled-out terminals, corrosion, etc.).</li> <li>Is there malfunction?</li> </ul>	Yes	Repair suspected terminal, then go to Step 8.
		No	Go to next step.



## ON-BOARD DIAGNOSTIC [ENGINE CONTROL SYSTEM (ZM)]

STEP	INSPECTION	ACTION	
4	<b>INSPECT FUEL GAUGE SENDER UNIT</b> <ul style="list-style-type: none"> <li>Inspect fuel gauge sender unit. (See 09–22–13 FUEL GAUGE SENDER UNIT INSPECTION)</li> <li>Is fuel gauge sender unit okay?</li> </ul>	Yes	Connect fuel gauge sender unit connector, then go to next step.
		No	Replace fuel gauge sender unit, then go to Step 8.
5	<b>INSPECT FTL SIGNAL CIRCUIT FOR OPEN CIRCUIT</b> <ul style="list-style-type: none"> <li>Turn ignition key to ON (Engine OFF).</li> <li>Measure voltage between fuel gauge sender unit terminal A (harness-side) and body ground.</li> <li>Is voltage <b>above 4.5–5.5 V</b>?</li> </ul>	Yes	Go to Step 8.
		No	Go to next step.
6	<b>INSPECT PCM CONNECTOR FOR POOR CONNECTION</b> <ul style="list-style-type: none"> <li>Turn ignition key to OFF.</li> <li>Disconnect PCM connector.</li> <li>Check for poor connection (damaged/pulled-out terminals, corrosion, etc.).</li> <li>Is there malfunction?</li> </ul>	Yes	Repair suspected terminal, then go to Step 8.
		No	Repair or replace open circuit between fuel gauge sender unit terminal A (harness-side) and PCM terminal 63 (harness-side), then go to Step 8.
7	<b>INSPECT FUEL GAUGE SENDER UNIT GROUND CIRCUIT FOR OPEN CIRCUIT</b> <ul style="list-style-type: none"> <li>Turn ignition key to OFF.</li> <li>Check for continuity between fuel gauge sender unit terminal C (harness-side) and body ground.</li> <li>Is there continuity?</li> </ul>	Yes	Go to next step.
		No	Repair or replace harness for open, then go to next step.
8	<b>VERIFY TROUBLESHOOTING OF DTC P0463 COMPLETED</b> <ul style="list-style-type: none"> <li>Make sure to reconnect all disconnected connectors.</li> <li>Turn ignition key to ON (Engine OFF).</li> <li>Clear DTC from memory using WDS or equivalent.</li> <li>Start engine.</li> <li>Is pending code of same DTC present?</li> </ul>	Yes	Replace PCM, then go to next step.
		No	No concern is detected. Go to next step.
9	<b>VERIFY AFTER REPAIR PROCEDURE</b> <ul style="list-style-type: none"> <li>Perform "After Repair Procedure". (See 01–02A–10 AFTER REPAIR PROCEDURE [ZM].)</li> <li>Is there any DTC present?</li> </ul>	Yes	Go to applicable DTC inspection. (See 01–02A–15 DTC TABLE [ZM].)
		No	Troubleshooting completed.

01–02A

### DTC P0464 [ZM]

A3U010201086W28

DTC P0464	Fuel gauge sender unit circuit performance (slosh check)
<b>DETECTION CONDITION</b>	<ul style="list-style-type: none"> <li>PCM monitors fuel gauge sender unit input voltage at PCM terminal 63 while engine is running. If differences are high for <b>14 seconds</b> while vehicle is stopped, PCM determines that FTL signal is incorrect.</li> </ul> <p><b>Diagnostic support note</b></p> <ul style="list-style-type: none"> <li>This is a continuous monitor (CCM).</li> <li>MIL illuminates if PCM detects the above malfunction condition in two consecutive drive cycles.</li> <li>PENDING CODE is available if PCM detects the above malfunction condition during first drive cycle.</li> <li>FREEZE FRAME DATA is available.</li> <li>DTC is stored in PCM memory.</li> </ul>
<b>POSSIBLE CAUSE</b>	<ul style="list-style-type: none"> <li>Fuel gauge sender unit malfunction or substandard performance</li> </ul>

### Diagnostic procedure

STEP	INSPECTION	ACTION	
1	<b>VERIFY FREEZE FRAME DATA HAS BEEN RECORDED</b> <ul style="list-style-type: none"> <li>Has FREEZE FRAME DATA been recorded?</li> </ul>	Yes	Go to next step.
		No	Record FREEZE FRAME DATA on repair order, then go to next step.
2	<b>VERIFY RELATED REPAIR INFORMATION AVAILABILITY</b> <ul style="list-style-type: none"> <li>Check for related Service Bulletins availability.</li> <li>Is any related repair information available?</li> </ul>	Yes	Perform repair or diagnosis according to available repair information. <ul style="list-style-type: none"> <li>If vehicle is not repaired, Go to next step.</li> </ul>
		No	Go to next step.

01–02A–91

# ON-BOARD DIAGNOSTIC [ENGINE CONTROL SYSTEM (ZM)]

STEP	INSPECTION		ACTION
3	<b>INSPECT FUEL GAUGE SENDER UNIT</b> <ul style="list-style-type: none"> <li>Turn ignition key to OFF.</li> <li>Inspect fuel gauge sender unit. (See 09-22-13 FUEL GAUGE SENDER UNIT INSPECTION.)</li> <li>Is fuel gauge sender unit okay?</li> </ul>	Yes	Replace PCM, then go to next step.
		No	Repair or replace fuel gauge sender unit, then go to next step.
4	<b>VERIFY AFTER REPAIR PROCEDURE</b> <ul style="list-style-type: none"> <li>Perform "After Repair Procedure". (See 01-02A-10 AFTER REPAIR PROCEDURE [ZM].)</li> <li>Is there any DTC present?</li> </ul>	Yes	Go to applicable DTC inspection. (See 01-02A-15 DTC TABLE [ZM].)
		No	Troubleshooting completed.

## DTC P0480 [ZM]

A3U010201086W29

DTC P0480	Cooling fan relay circuit
<b>DETECTION CONDITION</b>	<ul style="list-style-type: none"> <li>PCM monitors control signal to cooling fan relay coil control circuit. If signal at PCM terminal 47 remains low or high, PCM determines that cooling fan relay circuit has malfunction.</li> </ul> <p><b>Diagnostic support note</b></p> <ul style="list-style-type: none"> <li>This is a continuous monitor (CCM)</li> <li>PCM detects the above malfunction condition in two consecutive drive cycles.</li> <li>PENDING CODE is available if PCM detects the above malfunction condition during first drive cycles.</li> <li>FREEZE FRAME DATA is available.</li> <li>DTC is stored in PCM memory.</li> </ul>
<b>POSSIBLE CAUSE</b>	<ul style="list-style-type: none"> <li>Cooling fan relay malfunction</li> <li>Connector or terminal malfunction</li> <li>Short to GND circuit in wiring between cooling fan relay terminal B and PCM terminal 47</li> <li>Open circuit in wiring between cooling fan relay terminal B and PCM terminal 47</li> <li>Open circuit in wiring between main relay terminal D and cooling fan relay terminal C</li> <li>PCM malfunction</li> </ul>

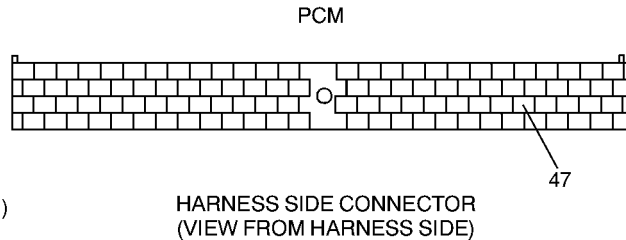
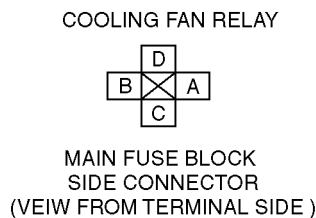
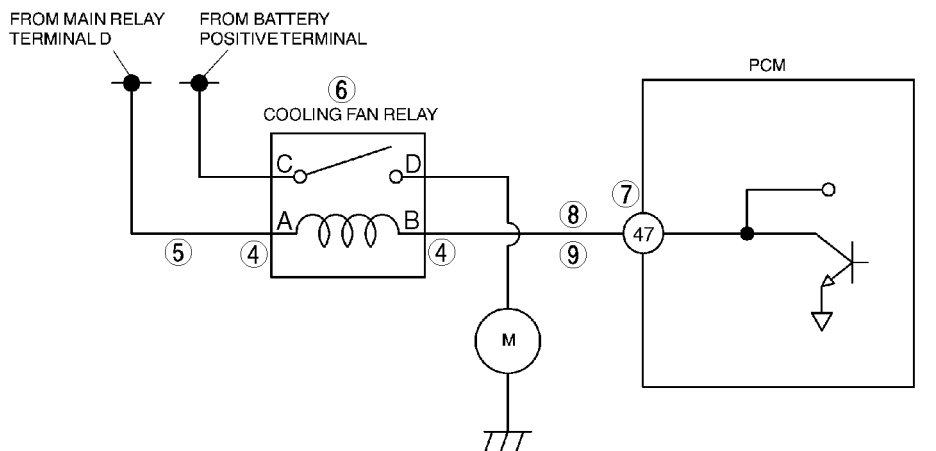

## ON-BOARD DIAGNOSTIC [ENGINE CONTROL SYSTEM (ZM)]

### Diagnostic procedure

STEP	INSPECTION	ACTION	
1	<b>VERIFY FREEZE FRAME DATA HAS BEEN RECORDED</b> <ul style="list-style-type: none"> <li>• Has FREEZE FRAME DATA been recorded?</li> </ul>	Yes	Go to next step.
		No	Record FREEZE FRAME DATA on repair order, then go to next step.
2	<b>VERIFY RELATED REPAIR INFORMATION AVAILABILITY</b> <ul style="list-style-type: none"> <li>• Check for related Service Bulletins and/or on-line repair information availability.</li> <li>• Is any Service Information available?</li> </ul>	Yes	Perform repair or diagnosis according to available repair Information. <ul style="list-style-type: none"> <li>• If vehicle is not repaired, go to next step.</li> </ul>
		No	Go to next step.
3	<b>CLASSIFY INTERMITTENT CONCERN OR CONTINUOUS CONCERN</b> <ul style="list-style-type: none"> <li>• Start engine.</li> <li>• Operate A/C to operate cooling fan relay.</li> <li>• Is same of DTC present?</li> </ul>	Yes	Go to next step.
		No	Refer to intermittent concern. (See 01-03A-4 INTERMITTENT CONCERN TROUBLESHOOTING [ZM].)
4	<b>INSPECT COOLING FAN RELAY FOR POOR CONNECTION</b> <ul style="list-style-type: none"> <li>• Turn ignition key to OFF.</li> <li>• Disconnect cooling fan relay connector.</li> <li>• Check for poor connection (damaged, pulled-out terminals, corrosion, etc.).</li> <li>• Is there malfunction?</li> </ul>	Yes	Repair or replace terminals, go to Step 10.
		No	Go to next step.
5	<b>INSPECT POWER CIRCUIT FOR OPEN CIRCUIT</b> <ul style="list-style-type: none"> <li>• Turn ignition key to ON (Engine OFF).</li> <li>• Measure voltage between cooling fan relay terminal C (harness-side) and body GND.</li> <li>• Is voltage <b>B+</b>?</li> </ul>	Yes	Go to next step.
		No	Repair or replace harness, go to Step 10.
6	<b>INSPECT COOLING FAN RELAY</b> <ul style="list-style-type: none"> <li>• Inspect cooling fan relay.</li> <li>• Is cooling fan relay okay?</li> </ul>	Yes	Go to next step.
		No	Replace cooling fan relay, go to Step 10.
7	<b>INSPECT PCM CONNECTOR FOR POOR CONNECTION</b> <ul style="list-style-type: none"> <li>• Disconnect PCM connector.</li> <li>• Check for poor connection at terminal 47 (damaged, pulled-out terminals, corrosion, etc.).</li> <li>• Is there malfunction?</li> </ul>	Yes	Repair terminal, go to Step 10.
		No	Go to next step.
8	<b>INSPECT CONTROL CIRCUIT FOR SHORT</b> <ul style="list-style-type: none"> <li>• Check for continuity between cooling fan relay terminal B (harness-side) and body GND.</li> <li>• Is there continuity?</li> </ul>	Yes	Repair or replace harness for short to GND, go to Step 10.
		No	Turn ignition switch to ON (Engine OFF). Measure voltage between cooling fan relay terminal B and body GND. <ul style="list-style-type: none"> <li>• If voltage is <b>B+</b>, repair or replace harness for short to power, go to next step.</li> <li>• If voltage is <b>approx. 0 V</b>, go to next step.</li> </ul>
9	<b>INSPECT CONTROL CIRCUIT FOR OPEN CIRCUIT</b> <ul style="list-style-type: none"> <li>• Turn ignition key to OFF.</li> <li>• Check for continuity between cooling fan relay terminal B (harness-side) and PCM terminal 47 (harness-side).</li> <li>• Is there continuity?</li> </ul>	Yes	Go to next step.
		No	Repair or replace harness for open, go to next step.
10	<b>VERIFY TROUBLESHOOTING OF DTC P0480 COMPLETED</b> <ul style="list-style-type: none"> <li>• Reconnect all disconnected connectors.</li> <li>• Clear DTC from memory using WDS or equivalent.</li> <li>• Start engine.</li> <li>• Operate A/C for operate cooling fan relay.</li> <li>• Is PENDING CODE of same DTC present?</li> </ul>	Yes	Replace PCM, go to next step.
		No	Go to next step.
11	<b>VERIFY AFTER REPAIR PROCEDURE</b> <ul style="list-style-type: none"> <li>• Perform "After Repair Procedure". (See 01-02A-10 AFTER REPAIR PROCEDURE [ZM].)</li> <li>• Is there any DTC present?</li> </ul>	Yes	Go to applicable DTC inspection. (See 01-02A-15 DTC TABLE [ZM].)
		No	Troubleshooting completed.

01-02A

# ON-BOARD DIAGNOSTIC [ENGINE CONTROL SYSTEM (ZM)]

**DTC P0500 [ZM]**

A3U010201087W06

<b>DTC P0500</b>	<b>Vehicle speed sensor (VSS) circuit malfunction (MTX)</b>
<b>DETECTION CONDITION</b>	<ul style="list-style-type: none"> <li>• Vehicle speed signal does not input after following conditions are met:                             <ul style="list-style-type: none"> <li>— Gear is in position other than neutral.</li> <li>— Load is above <b>40%</b>.</li> <li>— Engine speed is <b>2,000 rpm or above</b>.</li> </ul> </li> </ul> <p><b>Diagnostic support note:</b></p> <ul style="list-style-type: none"> <li>• This is a continuous monitor (CCM).</li> <li>• MIL illuminates if PCM detects the above malfunction conditions in two consecutive drive cycles.</li> <li>• PENDING CODE is available if PCM detects the above malfunction condition during first drive cycle.</li> <li>• FREEZE FRAME DATA is available.</li> <li>• DTC is stored in PCM memory.</li> </ul>
<b>POSSIBLE CAUSE</b>	<ul style="list-style-type: none"> <li>• PCM malfunction</li> <li>• Instrument cluster malfunction</li> <li>• ABS HU/CM malfunction</li> <li>• Open circuit between PCM terminal 58 and instrument cluster terminal 30</li> <li>• Short to ground between PCM terminal 58 and instrument cluster terminal 30</li> <li>• Vehicle speedometer sensor malfunction</li> <li>• Open circuit between vehicle speedometer sensor terminal A and instrument cluster terminal 3G</li> <li>• Short to ground between vehicle speedometer sensor terminal A and instrument cluster terminal 3G</li> <li>• Open circuit between vehicle speedometer sensor terminal B and instrument cluster terminal 3I</li> <li>• Short to ground between vehicle speedometer sensor terminal B and instrument cluster terminal 3I</li> </ul>

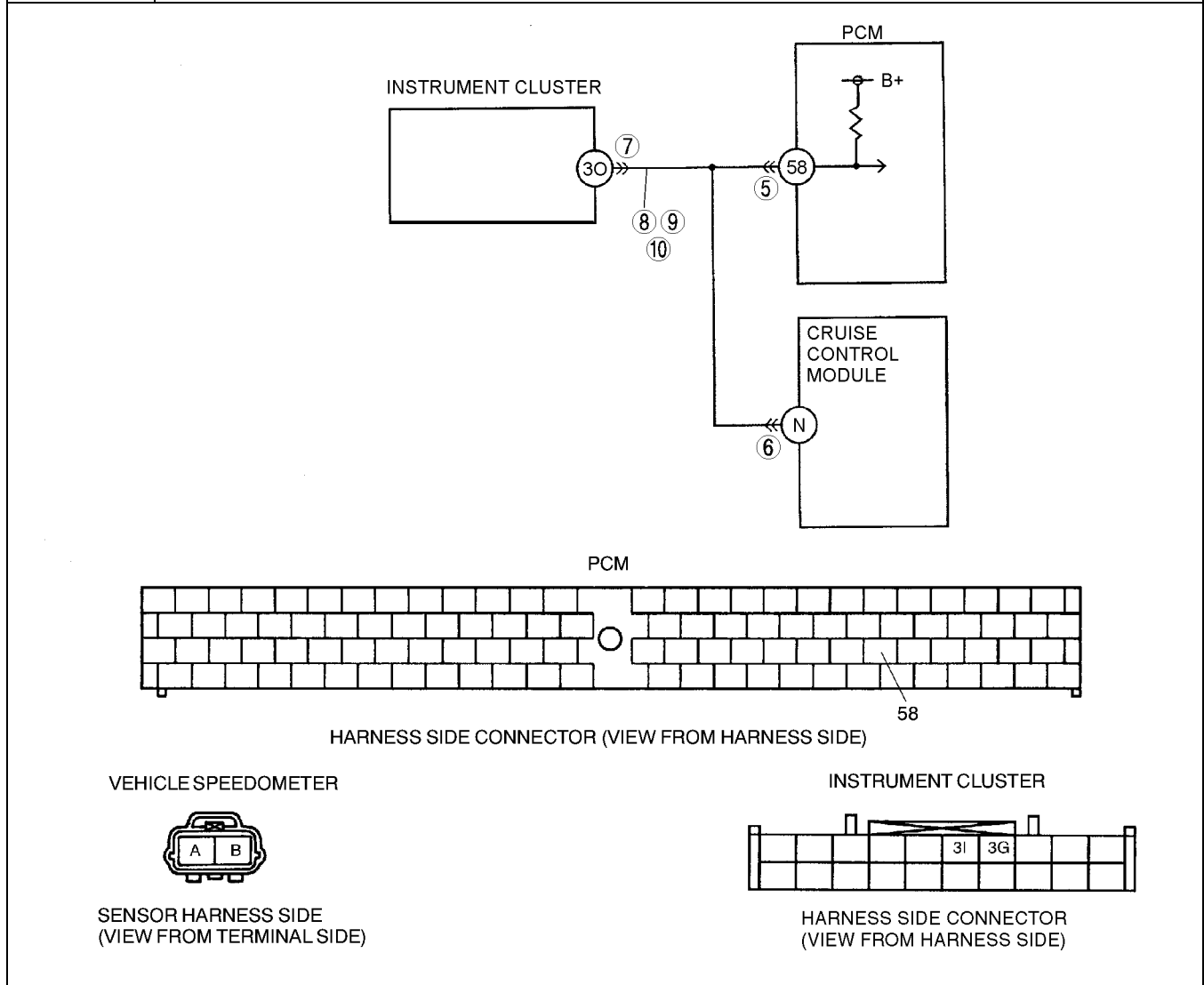

## ON-BOARD DIAGNOSTIC [ENGINE CONTROL SYSTEM (ZM)]

### Diagnostic procedure

STEP	INSPECTION	ACTION	
1	<b>VERIFY FREEZE FRAME DATA HAS BEEN RECORDED</b> <ul style="list-style-type: none"> <li>Has FREEZE FRAME PID DATA been recorded?</li> </ul>	Yes	Go to next step.
		No	Record FREEZE FRAME PID DATA on repair order, then go to next step.
2	<b>VERIFY RELATED REPAIR INFORMATION AVAILABILITY</b> <ul style="list-style-type: none"> <li>Check for related Service Bulletins availability.</li> <li>Is any related repair information available?</li> </ul>	Yes	Perform repair or diagnosis according to available repair information. <ul style="list-style-type: none"> <li>If vehicle is not repaired, go to next step.</li> </ul>
		No	Go to next step.
3	<b>VERIFY CURRENT INPUT SIGNAL STATUS-IS CONCERN INTERMITTENT OR CONSTANT</b> <ul style="list-style-type: none"> <li>Connect WDS or equivalent to DLC-2.</li> <li>Start engine.</li> <li>Access VS PID using WDS or equivalent.                             <ul style="list-style-type: none"> <li>Vehicle speed <b>20 km/h {12.4 mph}</b>: <b>20km/h {12.4 mph}</b></li> <li>Vehicle speed <b>40 km/h {24.8 mph}</b>: <b>40km/h {24.8 mph}</b></li> </ul> </li> <li>Are PID readings within specification?</li> </ul>	Yes	Go to intermittent concern troubleshooting procedure. (See 01-03A-4 INTERMITTENT CONCERN TROUBLESHOOTING [ZM].)
		No	Go to next step.
4	<b>CHECK INPUT/OUTPUT CHECK MODE</b> <ul style="list-style-type: none"> <li>Turn ignition key to ON (engine OFF).</li> <li>Is instrument cluster DTCs 10 or 12 detected? (See 09-22-5 INSTRUMENT CLUSTER INPUT/OUTPUT CHECK MODE.).</li> </ul>	Yes	DTC 10 and/or 12 displayed: Inspect Instrument cluster. (See 09-22-5 INSTRUMENT CLUSTER INPUT/OUTPUT CHECK MODE.)
		No	Go to next step.
5	<b>INSPECT PCM CONNECTOR FOR POOR CONNECTION</b> <ul style="list-style-type: none"> <li>Turn ignition key to OFF.</li> <li>Disconnect PCM connector.</li> <li>Check for poor connection (damaged/pulled-out terminals, corrosion, etc.).</li> <li>Are terminals okay?</li> </ul>	Yes	Go to next step.
		No	Repair or replace pin or connector, then go to Step 11.
6	<b>INSPECT CRUISE CONTROL MODULE CONNECTOR</b> <ul style="list-style-type: none"> <li>Disconnect cruise control module connector.</li> <li>Inspect for bent terminals.</li> <li>Are terminals okay?</li> </ul>	Yes	Go to next step.
		No	Repair terminals, then go to Step 11.
7	<b>INSPECT INSTRUMENT CLUSTER CONNECTOR FOR POOR CONNECTION</b> <ul style="list-style-type: none"> <li>Turn ignition key to OFF.</li> <li>Disconnect instrument cluster connector.</li> <li>Check for poor connections (damaged/pulled-out terminals, corrosion, etc.).</li> <li>Are terminals okay?</li> </ul>	Yes	Go to next step.
		No	Repair or replace terminals, then go to Step 11.
8	<b>INSPECT VOLTAGE</b> <ul style="list-style-type: none"> <li>Connect PCM connector.</li> <li>Turn ignition key to ON (engine OFF).</li> <li>Measure voltage at instrument cluster terminal 3O (harness-side).</li> <li>Is there <b>5 V</b> at instrument cluster terminal 3O (harness-side)?</li> </ul>	Yes	Replace instrument cluster, then go to Step 11. (See 09-22-3 INSTRUMENT CLUSTER REMOVAL/INSTALLATION.)
		No	Go to next step.
9	<b>INSPECT INSTRUMENT CLUSTER CIRCUIT FOR OPEN CIRCUIT</b> <ul style="list-style-type: none"> <li>Turn ignition key to OFF.</li> <li>Connect breakout box with PCM connector disconnected.</li> <li>Turn ignition key to ON (engine OFF).</li> <li>Check for continuity between instrument cluster terminal 3O (harness-side) and breakout box terminal 58.</li> <li>Is there continuity?</li> </ul>	Yes	Go to next step.
		No	Repair or replace harness, then go to Step 11.
10	<b>INSPECT INSTRUMENT CLUSTER CIRCUIT FOR SHORT TO GROUND</b> <ul style="list-style-type: none"> <li>Check for continuity between instrument cluster terminal 3O (harness-side) and body ground.</li> <li>Is there continuity?</li> </ul>	Yes	Repair or replace harness, then go to next step.
		No	Replace instrument cluster, then go to next step.

01-02A

## ON-BOARD DIAGNOSTIC [ENGINE CONTROL SYSTEM (ZM)]

STEP	INSPECTION	ACTION
11	<b>VERIFY TROUBLESHOOTING OF DTC P0500 COMPLETED</b> <ul style="list-style-type: none"> <li>Make sure to reconnect all disconnected connectors.</li> <li>Clear DTC from memory using WDS or equivalent.</li> <li>Warm up engine.</li> <li>Drive vehicle under following conditions for 16 seconds.                             <ul style="list-style-type: none"> <li>Engine speed: <b>1,800 rpm or above</b></li> <li>Gear: not in neutral.</li> <li>Load: <b>40% or above</b></li> </ul> </li> <li>Is PENDING CODE of same DTC present?</li> </ul>	Yes Replace PCM, then go to next step. (See 01-40A-7 PCM REMOVAL/INSTALLATION [ZM].)
		No Go to next step.
12	<b>VERIFY AFTER REPAIR PROCEDURE</b> <ul style="list-style-type: none"> <li>Perform "After Repair Procedure". (See 01-02A-10 AFTER REPAIR PROCEDURE [ZM].)</li> <li>Is there any DTC present?</li> </ul>	Yes Go to applicable DTC inspection.
		No Troubleshooting completed.

### DTC P0506 [ZM]

A3U010201087W07

DTC P0506	Idle control system RPM lower than expected
<b>DETECTION CONDITION</b>	<ul style="list-style-type: none"> <li>Actual idle speed is lower than expected by <b>100 rpm for 14 seconds</b> when brake pedal is depressed (brake switch is ON) and steering wheel is held straight ahead (power steering pressure switch is OFF).</li> </ul> <p><b>Note</b></p> <ul style="list-style-type: none"> <li>If atmospheric pressure is <b>less than 72.2 kPa {542 mmHg, 21.3 inHg}</b> or intake air temperature is <b>below -10°C {14°F}</b>, PCM cancels diagnosis of P0506.</li> </ul> <p><b>Diagnostic support note</b></p> <ul style="list-style-type: none"> <li>This is a continuous monitor (CCM).</li> <li>MIL illuminates if PCM detects the above malfunction condition in two consecutive drive cycles.</li> <li>PENDING CODE is available if PCM detects the above malfunction condition during first drive cycle.</li> <li>FREEZE FRAME DATA is available.</li> <li>DTC is stored in PCM memory.</li> </ul>
	<p><b>POSSIBLE CAUSE</b></p> <ul style="list-style-type: none"> <li>IAC valve malfunction</li> <li>Air cleaner element clogged</li> <li>Air intake passage clogged</li> <li>A/C relay control circuit malfunction</li> <li>Generator control circuit malfunction</li> <li>Purge solenoid valve malfunction</li> <li>Low engine compression (Over capacity of blow-by gas)</li> <li>PCM malfunction</li> </ul>

### Diagnostic procedure

STEP	INSPECTION	ACTION
1	<b>VERIFY FREEZE FRAME DATA HAS BEEN RECORDED</b> <ul style="list-style-type: none"> <li>Has FREEZE FRAME DATA been recorded?</li> </ul>	Yes Go to next step.
		No Record FREEZE FRAME DATA on repair order, then go to next step.
2	<b>VERIFY RELATED REPAIR INFORMATION AVAILABILITY</b> <ul style="list-style-type: none"> <li>Check for related Service Bulletins availability.</li> <li>Is any related repair information available?</li> </ul>	Yes Perform repair or diagnosis according to available repair information. <ul style="list-style-type: none"> <li>If vehicle is not repaired, go to next step.</li> </ul>
		No Go to next step.
3	<b>VERIFY RELATED PENDING OR STORED DTCS</b> <ul style="list-style-type: none"> <li>Turn ignition key to OFF, then ON (Engine OFF).</li> <li>Verify pending code or stored DTCs using WDS or equivalent.</li> <li>Are other DTCs present?</li> </ul>	Yes Repair applicable DTCs. (See 01-02A-15 DTC TABLE [ZM].)
		No Go to next step.
4	<b>INSPECT IAC VALVE MALFUNCTION</b> <ul style="list-style-type: none"> <li>Perform IAC inspection. (See 01-13A-7 IDLE AIR CONTROL (IAC) VALVE INSPECTION [ZM].)</li> <li>Is IAC valve okay?</li> </ul>	Yes Go to next step.
		No Replace IAC valve, then go to Step 11.

## ON-BOARD DIAGNOSTIC [ENGINE CONTROL SYSTEM (ZM)]

STEP	INSPECTION	ACTION
5	<b>INSPECT A/C MAGNETIC CLUTCH OPERATION</b> <ul style="list-style-type: none"> <li>• Turn blower motor switch off.</li> <li>• Is magnetic clutch still ON?</li> </ul>	Yes Refer to "A/C is always on or A/C compressor runs continuously." of ENGINE SYMPTOM TROUBLESHOOTING, then go to Step 11. (See 01-03A-46 NO.24 A/C IS ALWAYS ON/A/C COMPRESSOR RUNS CONTINUOUSLY [ZM].)
		No Go to next step.
6	<b>INSPECT GENERATOR CONTROL CIRCUIT MALFUNCTION</b> <ul style="list-style-type: none"> <li>• Turn ignition key to OFF.</li> <li>• Disconnect generator connector.</li> <li>• Turn ignition key to ON.</li> <li>• Measure voltage between generator connector terminal D (harness-side) and body GND.</li> <li>• Is voltage <b>0 V</b>?</li> </ul>	Yes Go to next step.
		No Repair short to power circuit in generator control circuit, then go to Step 11.
7	<b>INSPECT PURGE SOLENOID VALVE CONTROL MALFUNCTION</b> <ul style="list-style-type: none"> <li>• Perform purge solenoid valve. (See 01-16-12 PURGE SOLENOID VALVE INSPECTION.)</li> <li>• Is purge solenoid valve okay?</li> </ul>	Yes Go to next step.
		No Replace purge solenoid valve, then go to Step 11.
8	<b>INSPECT AIR CLEANER ELEMENT</b> <ul style="list-style-type: none"> <li>• Remove air cleaner element with engine running.</li> <li>• Is engine speed increased?</li> </ul>	Yes Replace air cleaner element, then go to Step 11.
		No Go to next step.
9	<b>INSPECT THROTTLE BODY PASSAGE</b> <ul style="list-style-type: none"> <li>• Is throttle body passage clogged?</li> </ul>	Yes Clean or replace throttle body, then go to Step 11.
		No Go to next step.
10	<b>INSPECT ENGINE COMPRESSION</b> <ul style="list-style-type: none"> <li>• Inspect engine compression. (See 01-10A-8 COMPRESSION INSPECTION [ZM].)</li> <li>• Is engine compression okay?</li> </ul>	Yes Go to next step.
		No Overhaul engine, then go to next step.
11	<b>VERIFY TROUBLESHOOTING OF DTC P0506 COMPLETED</b> <ul style="list-style-type: none"> <li>• Make sure to reconnect all disconnected connectors.</li> <li>• Start engine.</li> <li>• Clear DTC from PCM memory using WDS or equivalent.</li> <li>• Depress brake pedal for <b>14.1 seconds or more</b>.</li> <li>• Is PENDING CODE of same DTC present?</li> </ul>	Yes Replace PCM, then go to next step.
		No Go to next step.
12	<b>VERIFY AFTER REPAIR PROCEDURE</b> <ul style="list-style-type: none"> <li>• Perform "After Repair Procedure". (See 01-02A-10 AFTER REPAIR PROCEDURE [ZM].)</li> <li>• Is there any DTC present?</li> </ul>	Yes Go to applicable DTC inspection. (See 01-02A-15 DTC TABLE [ZM].)
		No Troubleshooting completed.

01-02A

### DTC P0507 [ZM]

A3U010201087W08

DTC P0507	Idle control system RPM higher than expected
<b>DETECTION CONDITION</b>	<ul style="list-style-type: none"> <li>• Actual idle speed is higher than expected by <b>200 rpm for 14 seconds</b>, when brake pedal is depressed (brake switch is ON) and steering wheel is held straight ahead (power steering pressure switch is OFF).</li> </ul> <p><b>Note</b></p> <ul style="list-style-type: none"> <li>• If atmospheric pressure is <b>less than 72.2 kPa {542 mmHg, 21.3 inHg}</b> or intake air temperature is <b>below -10°C {14°F}</b>, PCM cancels diagnosis of P0507.</li> </ul> <p><b>Diagnostic support note</b></p> <ul style="list-style-type: none"> <li>• This is a continuous monitor (CCM).</li> <li>• MIL illuminates if PCM detects the above malfunction condition in two consecutive drive cycles.</li> <li>• PENDING CODE is available if PCM detects the above malfunction condition during first drive cycle.</li> <li>• FREEZE FRAME DATA is available.</li> <li>• DTC is stored in PCM memory.</li> </ul>

## ON-BOARD DIAGNOSTIC [ENGINE CONTROL SYSTEM (ZM)]

<b>DTC P0507</b>	<b>Idle control system RPM higher than expected</b>
<b>POSSIBLE CAUSE</b>	<ul style="list-style-type: none"> <li>• IAC valve malfunction</li> <li>• Accelerator cable misadjustment</li> <li>• Actuator cable misadjustment</li> <li>• Throttle valve malfunction</li> <li>• Vacuum hose misconnection</li> <li>• PCM malfunction</li> </ul>

### Diagnostic procedure

STEP	INSPECTION		ACTION
1	<b>VERIFY FREEZE FRAME DATA HAS BEEN RECORDED</b> <ul style="list-style-type: none"> <li>• Has FREEZE FRAME DATA been recorded?</li> </ul>	Yes	Go to next step.
		No	Record FREEZE FRAME DATA on repair order, then go to next step.
2	<b>VERIFY RELATED REPAIR INFORMATION AVAILABILITY</b> <ul style="list-style-type: none"> <li>• Check for related Service Bulletins availability.</li> <li>• Is any related repair information available?</li> </ul>	Yes	Perform repair or diagnosis according to available repair information. <ul style="list-style-type: none"> <li>• If vehicle is not repaired, go to next step.</li> </ul>
		No	Go to next step.
3	<b>VERIFY RELATED PENDING OR STORED DTCs</b> <ul style="list-style-type: none"> <li>• Turn ignition key to OFF, then start engine.</li> <li>• Verify pending code or stored DTCs using WDS or equivalent.</li> <li>• Are other DTCs present?</li> </ul>	Yes	Repair applicable DTCs. (See 01-02A-15 DTC TABLE [ZM].)
		No	Go to next step.
4	<b>INSPECT IAC VALVE MALFUNCTION</b> <ul style="list-style-type: none"> <li>• Perform IAC inspection. (See 01-13A-7 IDLE AIR CONTROL (IAC) VALVE INSPECTION [ZM].)</li> <li>• Is IAC valve okay?</li> </ul>	Yes	Go to next step.
		No	Replace IAC valve, then go to Step 9.
5	<b>INSPECT ACCELERATOR CABLE FREE PLAY</b> <ul style="list-style-type: none"> <li>• Turn ignition key to OFF.</li> <li>• Is accelerator cable free play okay? (See 01-13A-13 ACCELERATOR CABLE INSPECTION/ADJUSTMENT [ZM].)</li> </ul>	Yes	Go to next step.
		No	Adjust accelerator cable free play, then go to Step 9. (See 01-13A-13 ACCELERATOR CABLE INSPECTION/ADJUSTMENT [ZM].)
6	<b>INSPECT ACTUATOR CABLE FREE PLAY</b> <ul style="list-style-type: none"> <li>• Is actuator cable adjustment okay?</li> </ul>	Yes	Go to next step.
		No	Adjust actuator cable free play, then go to Step 9.
7	<b>INSPECT VACUUM HOSE CONNECTION</b> <ul style="list-style-type: none"> <li>• Are vacuum hoses connected accurately? (See 01-13A-3 VACUUM HOSE ROUTING DIAGRAM [ZM].)</li> </ul>	Yes	Go to next step.
		No	Reconnect vacuum hose accurately, then go to Step 9.
8	<b>VISUAL INSPECT THROTTLE VALVE</b> <ul style="list-style-type: none"> <li>• Remove throttle body.</li> <li>• Is throttle valve fully closed?</li> </ul>	Yes	Go to next step.
		No	Clean or replace throttle body, then go to next step.
9	<b>VERIFY TROUBLESHOOTING OF DTC P0507 COMPLETED</b> <ul style="list-style-type: none"> <li>• Make sure to reconnect all disconnected connectors.</li> <li>• Start engine.</li> <li>• Clear DTC from PCM memory using WDS or equivalent.</li> <li>• Depress brake pedal for <b>14.1 seconds or more</b>.</li> <li>• Is PENDING CODE of same DTC present?</li> </ul>	Yes	Replace PCM, then go to next step.
		No	Go to next step.
10	<b>VERIFY AFTER REPAIR PROCEDURE</b> <ul style="list-style-type: none"> <li>• Perform "After Repair Procedure". (See 01-02A-10 AFTER REPAIR PROCEDURE [ZM].)</li> <li>• Is there any DTC present?</li> </ul>	Yes	Go to applicable DTC inspection. (See 01-02A-15 DTC TABLE [ZM].)
		No	Troubleshooting completed.



# ON-BOARD DIAGNOSTIC [ENGINE CONTROL SYSTEM (ZM)]

DTC P0550 [ZM]

A3U010201087W09

01-02A

<b>DTC P0550</b>	<b>PSP switch circuit malfunction</b>
<b>DETECTION CONDITION</b>	<ul style="list-style-type: none"> <li>PCM monitors PSP switch signal at PCM terminal 31. If input voltage is low (switch stays on) for <b>1 minute</b> when the VSS is <b>above 60.1 km/h {37.3 mph}</b> and ECT is <b>above 60°C {140°F}</b>, PCM determines that PSP switch circuit has malfunction.</li> </ul> <p><b>Diagnostic support note</b></p> <ul style="list-style-type: none"> <li>This is a continuous monitor (CCM).</li> <li>MIL illuminates if PCM detects the above malfunction condition in two consecutive drive cycles.</li> <li>PENDING CODE is available if PCM detects the above malfunction condition during first drive cycle.</li> <li>FREEZE FRAME DATA is available.</li> <li>DTC is stored in PCM memory.</li> </ul>
<b>POSSIBLE CAUSE</b>	<ul style="list-style-type: none"> <li>PSP switch malfunction</li> <li>Short to ground between PSP switch terminal and PCM terminal 31</li> <li>PCM malfunction</li> </ul>

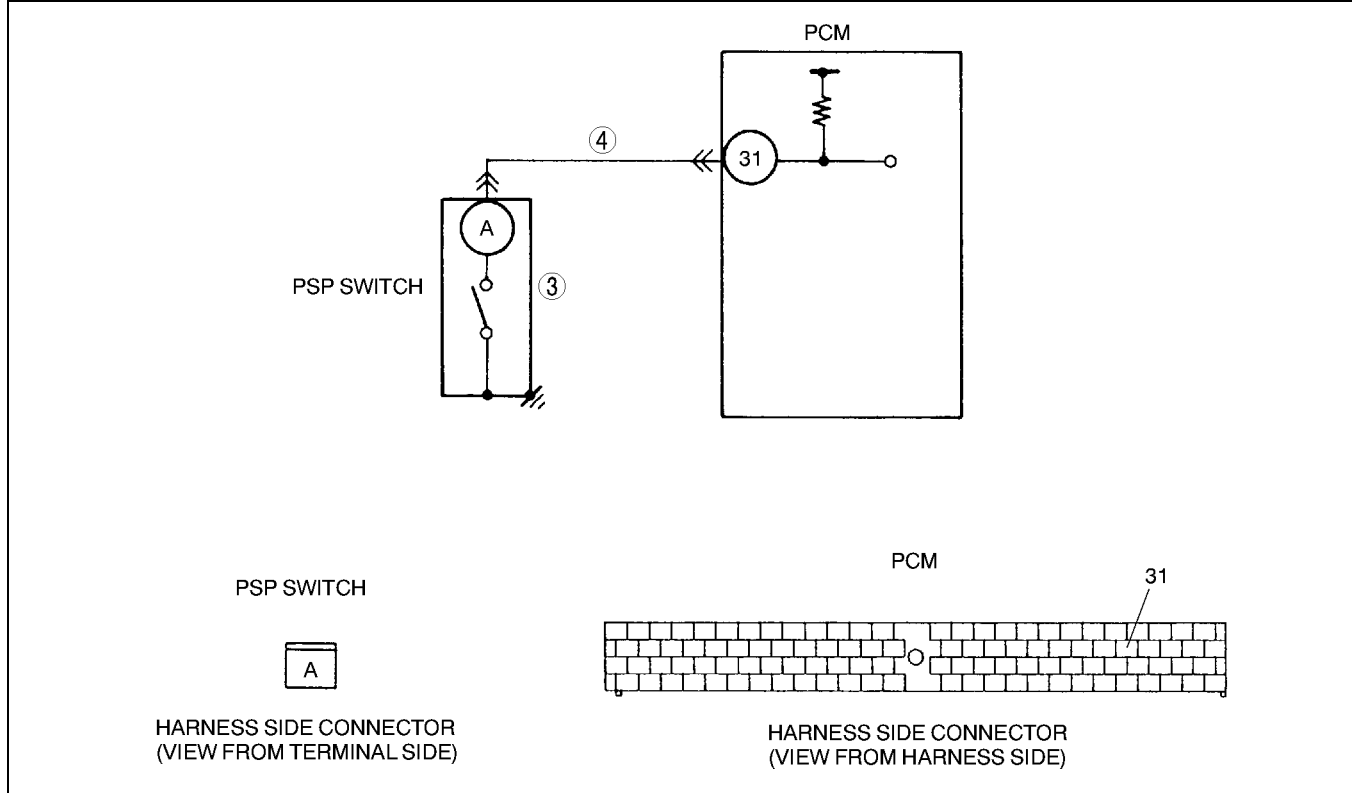

**Diagnostic procedure**

STEP	INSPECTION		ACTION
1	<b>VERIFY FREEZE FRAME DATA HAS BEEN RECORDED</b> <ul style="list-style-type: none"> <li>Has FREEZE FRAME DATA been recorded?</li> </ul>	Yes	Go to next step.
		No	Record FREEZE FRAME DATA on repair order, then go to next step.
2	<b>VERIFY RELATED REPAIR INFORMATION AVAILABILITY</b> <ul style="list-style-type: none"> <li>Check for related Service Bulletins availability.</li> <li>Is any related repair information available?</li> </ul>	Yes	Perform repair or diagnosis according to available repair information. <ul style="list-style-type: none"> <li>If vehicle is not repaired, go to next step.</li> </ul>
		No	Go to next step.
3	<b>INSPECT PSP SWITCH</b> <ul style="list-style-type: none"> <li>Perform PSP switch inspection (See 01-40A-43 POWER STEERING PRESSURE (PSP) SWITCH INSPECTION [ZM].)</li> <li>Is PSP switch okay?</li> </ul>	Yes	Go to next step.
		No	Replace the PSP switch, then go to Step 5.
4	<b>INSPECT PSP SWITCH SIGNAL CIRCUIT FOR SHORT TO GROUND</b> <ul style="list-style-type: none"> <li>Disconnect PCM connector.</li> <li>Check for continuity between PSP switch terminal (harness-side) and body ground.</li> <li>Is there continuity?</li> </ul>	Yes	Repair or replace harness for short to ground, then go to next step.
		No	Go to next step.

# ON-BOARD DIAGNOSTIC [ENGINE CONTROL SYSTEM (ZM)]

STEP	INSPECTION		ACTION
5	<b>VERIFY TROUBLESHOOTING OF DTC P0550 COMPLETED</b> <ul style="list-style-type: none"> <li>Make sure to reconnect all disconnected connectors.</li> <li>Start engine.</li> <li>Clear DTC from PCM memory using WDS or equivalent.</li> <li>Drive vehicle <b>above 60.1 km/h {37.3 mph}</b> for <b>1 minute</b>.</li> <li>Verify that ECT PID is <b>above 60°C {140°F}</b> using WDS or equivalent.</li> <li>Is PENDING CODE of same DTC present?</li> </ul>	Yes	Replace PCM, then go to next step.
		No	No concern is detected. Go to next step.
6	<b>VERIFY AFTER REPAIR PROCEDURE</b> <ul style="list-style-type: none"> <li>Perform "After Repair Procedure". (See 01-02A-10 AFTER REPAIR PROCEDURE [ZM].)</li> <li>Is there any DTC present?</li> </ul>	Yes	Go to applicable DTC inspection. (See 01-02A-15 DTC TABLE [ZM].)
		No	Troubleshooting completed.

## DTC P0703 [ZM]

A3U010201089W04

DTC P0703	Brake switch input malfunction
<b>DETECTION CONDITION</b>	<ul style="list-style-type: none"> <li>PCM monitors changes in input voltage from brake switch. If PCM does not detect PCM terminal 92 voltage changes while accelerating and decelerating <b>10 times</b> repeatedly, it determines that brake switch circuit has malfunction.</li> </ul> <p><b>Diagnostic support note</b></p> <ul style="list-style-type: none"> <li>This is a continuous monitor (CCM).</li> <li>MIL illuminates if PCM detects the above malfunction condition in two consecutive drive cycles.</li> <li>PENDING CODE is available if PCM detects the above malfunction condition during first drive cycle.</li> <li>FREEZE FRAME DATA is available.</li> <li>DTC is stored in PCM memory.</li> </ul>
<b>POSSIBLE CAUSE</b>	<ul style="list-style-type: none"> <li>Brake switch malfunction</li> <li>Open harness between brake switch terminal B and PCM connector terminal 92</li> <li>PCM malfunction</li> </ul>

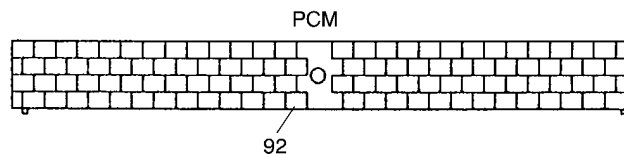
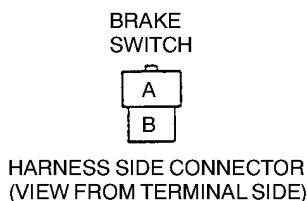
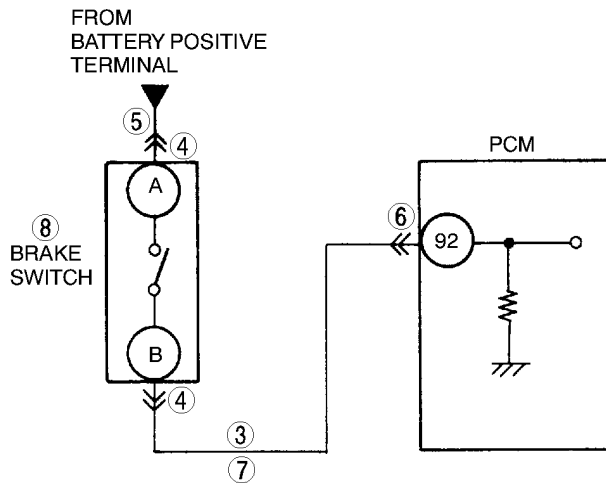

## ON-BOARD DIAGNOSTIC [ENGINE CONTROL SYSTEM (ZM)]

### Diagnostic procedure

STEP	INSPECTION	ACTION	
1	<b>VERIFY FREEZE FRAME DATA HAS BEEN RECORDED</b> <ul style="list-style-type: none"> <li>• Has FREEZE FRAME DATA been recorded?</li> </ul>	Yes	Go to next step.
		No	Record FREEZE FRAME DATA on repair order, then go to next step.
2	<b>VERIFY RELATED REPAIR INFORMATION AVAILABILITY</b> <ul style="list-style-type: none"> <li>• Check for related Service Bulletins availability.</li> <li>• Is any related repair information available?</li> </ul>	Yes	Perform repair or diagnosis according to available repair information. <ul style="list-style-type: none"> <li>• If vehicle is not repaired, go to next step.</li> </ul>
		No	Go to next step.
3	<b>INSPECT BRAKE SWITCH SIGNAL CIRCUIT FOR SHORT TO POWER</b> <ul style="list-style-type: none"> <li>• Measure voltage between brake switch connector terminal B and body ground.</li> <li>• Is voltage <b>B+</b>?</li> </ul>	Yes	Repair or replace harness for short to power, then go to Step 9.
		No	Go to Next step.
4	<b>INSPECT BRAKE SWITCH CONNECTOR FOR POOR CONNECTION</b> <ul style="list-style-type: none"> <li>• Turn ignition switch to OFF.</li> <li>• Disconnect brake switch connector.</li> <li>• Check for poor connection (damaged/pulled-out terminals, corrosion, etc.).</li> <li>• Is there malfunction?</li> </ul>	Yes	Repair or replace terminal, then go to Step 9.
		No	Go to next step.
5	<b>INSPECT BRAKE SWITCH POWER CIRCUIT FOR OPEN CIRCUIT</b> <ul style="list-style-type: none"> <li>• Measure voltage between brake switch connector terminal A and body ground.</li> <li>• Is voltage <b>B+</b>?</li> </ul>	Yes	Go to next step.
		No	Repair or replace brake switch power circuit for open, then Go to Step 9.
6	<b>INSPECT PCM CONNECTOR FOR POOR CONNECTION</b> <ul style="list-style-type: none"> <li>• Turn ignition switch to OFF.</li> <li>• Disconnect PCM connector.</li> <li>• Check for poor connection (damaged/pulled-out terminals, corrosion, etc.).</li> <li>• Is there any malfunction?</li> </ul>	Yes	Repair terminal, then go to Step 9.
		No	Go to next step.
7	<b>INSPECT BRAKE SWITCH SIGNAL CIRCUIT FOR OPEN CURCUIT</b> <ul style="list-style-type: none"> <li>• Connect breakout box with PCM connector disconnected.</li> <li>• Connect brake switch connector.</li> <li>• Turn ignition switch to ON (engine OFF).</li> <li>• Depress brake pedal and measure voltage between breakout box terminal 92 and body ground.</li> <li>• Is voltage <b>B+</b>?</li> </ul>	Yes	Go to next step.
		No	Repair or replace harness for open, then go to Step 9.
8	<b>INSPECT BRAKE SWITCH</b> <ul style="list-style-type: none"> <li>• Perform brake switch inspection. (See 04-11-5 BRAKE SWITCH INSPECTION.)</li> <li>• Is brake switch okay?</li> </ul>	Yes	Go to next step.
		No	Replace brake switch, then go to next step.
9	<b>VERIFY TROUBLESHOOTING OF DTC P0703 COMPLETED</b> <ul style="list-style-type: none"> <li>• Make sure to reconnect all disconnected connectors.</li> <li>• Clear DTC from memory using WDS or equivalent.</li> <li>• Drive vehicle <b>30 km/h {18.6 mph} or more.</b></li> <li>• Depress and release brake pedal <b>more than 10 times</b> while driving vehicle.</li> <li>• Is PENDING CODE of same DTC present?</li> </ul>	Yes	Replace PCM, then go to next step.
		No	No concern is detected. Go to next step.
10	<b>VERIFY AFTER REPAIR PROCEDURE</b> <ul style="list-style-type: none"> <li>• Perform "After Repair Procedure". (See 01-02A-10 AFTER REPAIR PROCEDURE [ZM].)</li> <li>• Is there any DTC present?</li> </ul>	Yes	Go to applicable DTC inspection. (See 01-02A-15 DTC TABLE [ZM].)
		No	Troubleshooting completed.

01-02A

# ON-BOARD DIAGNOSTIC [ENGINE CONTROL SYSTEM (ZM)]

DTC P0704 [ZM]

A3U010201089W05

<b>DTC P0704</b>	<b>Clutch switch circuit malfunction</b>
<b>DETECTION CONDITION</b>	<ul style="list-style-type: none"> <li>PCM monitors changes in input voltage from the clutch switch. If PCM does not detect PCM terminal 6 voltage changes while running vehicle with vehicle speed <b>above 30 km/h {19 mph}</b> and stopping vehicle <b>10 times</b> repeatedly, it determines that clutch switch circuit has malfunction.</li> </ul> <p><b>Diagnostic support note</b></p> <ul style="list-style-type: none"> <li>This is a continuous monitor (CCM).</li> <li>MIL illuminates if PCM detects the above the above malfunction condition in two consecutive drive cycles.</li> <li>PENDING CODE is available if PCM detects the above malfunction condition during first drive cycle.</li> <li>FREEZE FRAME DATA is available.</li> <li>DTC is stored in PCM memory.</li> </ul>
<b>POSSIBLE CAUSE</b>	<ul style="list-style-type: none"> <li>CLT switch malfunction</li> <li>Open harness between clutch switch terminal A and PCM terminal 6</li> <li>PCM malfunction</li> </ul>

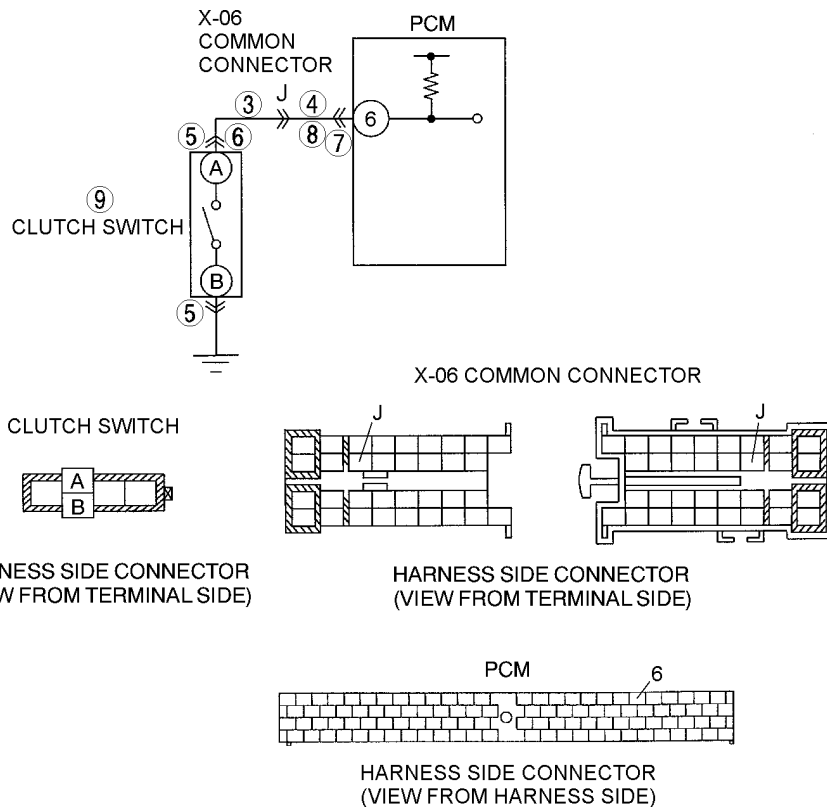

## Diagnostic procedure

STEP	INSPECTION		ACTION
1	<b>VERIFY FREEZE FRAME DATA HAS BEEN RECORDED</b> <ul style="list-style-type: none"> <li>Has FREEZE FRAME DATA been recorded?</li> </ul>	Yes	Go to next step.
		No	Record FREEZE FRAME DATA on repair order, then go to next step.
2	<b>VERIFY RELATED REPAIR INFORMATION AVAILABILITY</b> <ul style="list-style-type: none"> <li>Check for related Service Bulletins availability.</li> <li>Is any related repair information available?</li> </ul>	Yes	Perform repair or diagnosis according to available repair information. <ul style="list-style-type: none"> <li>If vehicle is not repaired, go to next step.</li> </ul>
		No	Go to next step.
3	<b>INSPECT X-06 COMMON CONNECTOR CIRCUIT FOR SHORT TO POWER</b> <ul style="list-style-type: none"> <li>Disconnect X-06 common connector.</li> <li>Turn ignition key to ON (engine OFF).</li> <li>Measure voltage between X-06 common connector male terminal J and body ground.</li> <li>Is voltage <b>B+</b>?</li> </ul>	Yes	Repair or replace harness for short to power, then go to Step 10.
		No	Go to next step.

## ON-BOARD DIAGNOSTIC [ENGINE CONTROL SYSTEM (ZM)]

STEP	INSPECTION	ACTION
4	<b>INSPECT CLUTCH SWITCH SIGNAL CIRCUIT FOR SHORT TO POWER</b> <ul style="list-style-type: none"> <li>• Turn ignition key OFF.</li> <li>• Connect breakout box with PCM connector disconnected.</li> <li>• Turn ignition key to ON (engine OFF).</li> <li>• Measure voltage between breakout box terminal 6 and body ground.</li> <li>• Is voltage <b>B+</b>?</li> </ul>	Yes Repair or replace harness for short to power, then go to Step 10.
		No Go to next step.
5	<b>INSPECT CLUTCH SWITCH CONNECTOR FOR POOR CONNECTION</b> <ul style="list-style-type: none"> <li>• Turn ignition key to OFF.</li> <li>• Disconnect clutch switch connector.</li> <li>• Check for poor connection (damaged/pilled-out terminals, corrosion, etc.).</li> <li>• Is there malfunction?</li> </ul>	Yes Repair or replace terminal, then go Step 10.
		No Go to next step.
6	<b>INSPECT CLUTCH SWITCH SIGNAL CIRCUIT FOR OPEN CIRCUIT</b> <ul style="list-style-type: none"> <li>• Make sure to reconnect all disconnected connectors.</li> <li>• Turn ignition key to ON (engine OFF).</li> <li>• Measure voltage between clutch switch terminal A and body ground.</li> <li>• Is voltage <b>B+</b>?</li> </ul>	Yes Go to next step.
		No Repair or replace clutch switch signal circuit for open, then go to Step 10.
7	<b>INSPECT PCM CONNECTOR FOR POOR CONNECTION</b> <ul style="list-style-type: none"> <li>• Turn ignition key to OFF.</li> <li>• Disconnect PCM connector.</li> <li>• Check for poor connection at terminal 6 (damaged/pulled-out terminals, corrosion, etc.).</li> <li>• Is there malfunction?</li> </ul>	Yes Repair terminal, then go to Step 10.
		No Go to next step.
8	<b>INSPECT X-06 COMMON CONNECTOR CIRCUIT FOR OPEN CIRCUIT</b> <ul style="list-style-type: none"> <li>• Disconnect X-06 common connector.</li> <li>• Turn ignition key to ON (engine OFF).</li> <li>• Depress clutch pedal and measure voltage between X-06 common connector male terminal J and body ground.</li> <li>• Is voltage <b>B+</b>?</li> </ul>	Yes Go to next step.
		No Repair or replace harness for open, then go to Step 10.
9	<b>INSPECT CLUTCH SWITCH</b> <ul style="list-style-type: none"> <li>• Perform clutch switch inspection. (See 01-40A-41 CLUTCH SWITCH INSPECTION [ZM].)</li> <li>• Is clutch switch okay?</li> </ul>	Yes Go to next step.
		No Replace clutch switch, then go to next step.
10	<b>VERIFY TROUBLESHOOTING OF DTC P0704 COMPLETED</b> <ul style="list-style-type: none"> <li>• Make sure to reconnect all disconnected connectors.</li> <li>• Start engine.</li> <li>• Clear DTC from PCM memory using WDS or equivalent.</li> <li>• Drive vehicle <b>above 29.8 km/h {18.5 mph}</b> and stop vehicle.</li> <li>• Depress and release clutch pedal <b>more than 10 times</b> during drive cycle.</li> <li>• Is PENDING CODE of same DTC present?</li> </ul>	Yes Replace PCM, then go to next step.
		No No concern is detected. Go to next step.
11	<b>VERIFY AFTER REPAIR PROCEDURE</b> <ul style="list-style-type: none"> <li>• Perform "After Repair Procedure". (See 01-02A-10 AFTER REPAIR PROCEDURE [ZM].)</li> <li>• Is there any DTC present?</li> </ul>	Yes Go to applicable DTC inspection. (See 01-02A-15 DTC TABLE [ZM].)
		No Troubleshooting completed.

01-02A

# ON-BOARD DIAGNOSTIC [ENGINE CONTROL SYSTEM (ZM)]

DTC P0705 [ZM]

A3U010201089W06

<b>DTC P0705</b>	<b>Neutral switch circuit malfunction</b>
<b>DETECTION CONDITION</b>	<ul style="list-style-type: none"> <li>PCM monitors changes in input voltage from neutral switch. If PCM does not detect PCM terminal 64 voltage changes when clutch pedal is depressed <b>10 times</b> while driving with vehicle speed <b>above 30 km/h {19 mph}</b> and vehicle stopped repeatedly, it determines that neutral switch circuit has malfunction.</li> </ul> <p><b>Diagnostic support note</b></p> <ul style="list-style-type: none"> <li>This is a continuous monitor (CCM).</li> <li>MIL illuminates if PCM detects the above the above malfunction condition in two consecutive drive cycles.</li> <li>PENDING CODE is available if PCM detects the above malfunction condition during first drive cycle.</li> <li>FREEZE FRAME DATA is available.</li> <li>DTC is stored in PCM memory.</li> </ul>
<b>POSSIBLE CAUSE</b>	<ul style="list-style-type: none"> <li>Neutral switch malfunction</li> <li>Open harness between neutral switch terminal A and PCM terminal 64</li> <li>PCM malfunction</li> </ul>

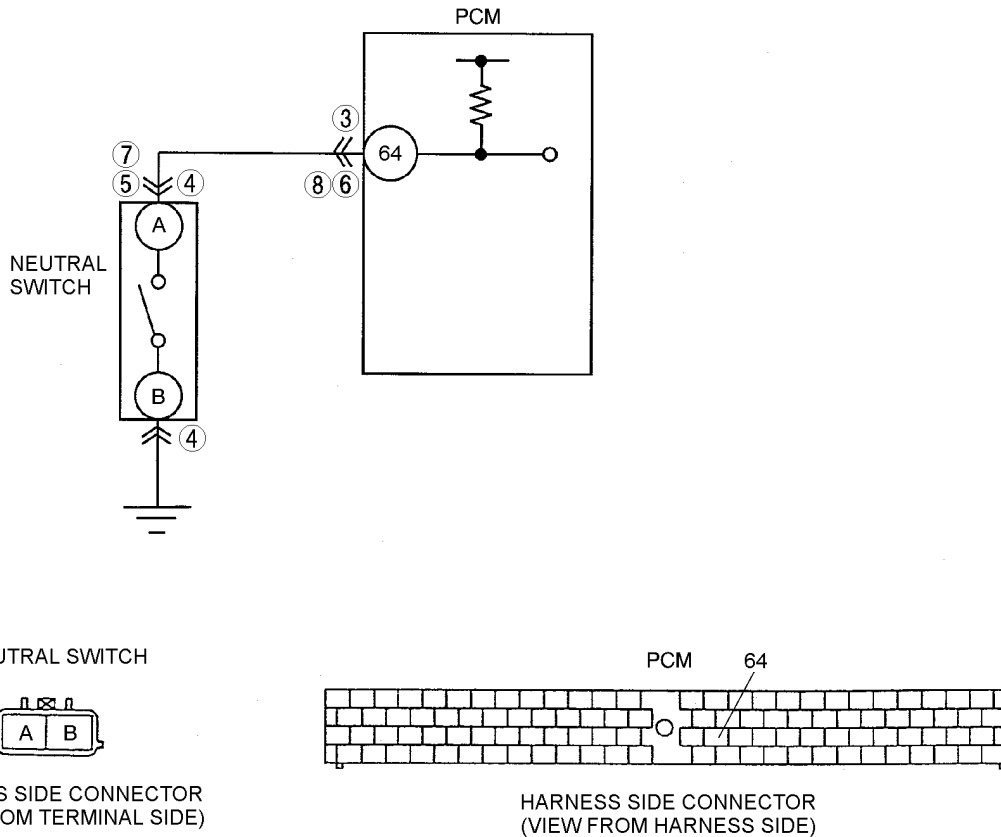

**Diagnostic procedure**

STEP	INSPECTION		ACTION
1	<b>VERIFY FREEZE FRAME DATA HAS BEEN RECORDED</b> <ul style="list-style-type: none"> <li>Has FREEZE FRAME DATA been recorded?</li> </ul>	Yes	Go to next step.
		No	Record FREEZE FRAME DATA on repair order, then go to next step.
2	<b>VERIFY RELATED REPAIR INFORMATION AVAILABILITY</b> <ul style="list-style-type: none"> <li>Check for related Service Bulletins availability.</li> <li>Is any related repair information available?</li> </ul>	Yes	Perform repair or diagnosis according to available repair information. <ul style="list-style-type: none"> <li>If vehicle is not repaired, go to next step.</li> </ul>
		No	Go to next step.

## ON-BOARD DIAGNOSTIC [ENGINE CONTROL SYSTEM (ZM)]

STEP	INSPECTION	ACTION	
3	<b>INSPECT NEUTRAL SWITCH SIGNAL CIRCUIT FOR SHORT TO POWER</b> <ul style="list-style-type: none"> <li>• Connect breakout box with PCM connector disconnected.</li> <li>• Disconnect neutral switch connector.</li> <li>• Turn ignition key to ON (engine OFF).</li> <li>• Measure voltage between breakout box terminal 64 (harness-side) and body ground.</li> <li>• Is voltage <b>B+</b>?</li> </ul>	Yes	Repair or replace harness for short to power, then go to Step 9.
		No	Go to next step.
4	<b>INSPECT POOR CONNECTION OF NEUTRAL SWITCH CONNECTOR</b> <ul style="list-style-type: none"> <li>• Turn ignition key to OFF.</li> <li>• Disconnect neutral switch connector.</li> <li>• Check for poor connection (damaged/pulled-out terminals, corrosion, etc.).</li> <li>• Is there malfunction?</li> </ul>	Yes	Repair or replace terminal, then go Step 9.
		No	Go to next step.
5	<b>INSPECT NEUTRAL SWITCH SIGNAL CIRCUIT FOR OPEN CIRCUIT</b> <ul style="list-style-type: none"> <li>• Make sure to reconnect all disconnected connector.</li> <li>• Turn ignition key to ON (engine OFF).</li> <li>• Measure voltage between neutral switch terminal A (harness-side) and body ground.</li> <li>• Is voltage <b>B+</b>?</li> </ul>	Yes	Go to next step.
		No	Repair or replace neutral switch signal circuit for open, then go to Step 9.
6	<b>INSPECT PCM CONNECTOR FOR POOR CONNECTION</b> <ul style="list-style-type: none"> <li>• Turn ignition key to OFF.</li> <li>• Disconnect PCM connector.</li> <li>• Check for poor connection at terminal 64 (damaged/pulled-out terminals, corrosion, etc.).</li> <li>• Is there malfunction?</li> </ul>	Yes	Repair terminal, then go to Step 9.
		No	Go to next step.
7	<b>INSPECT NEUTRAL SWITCH CONNECTOR CIRCUIT FOR OPEN CIRCUIT</b> <ul style="list-style-type: none"> <li>• Disconnect neutral switch connector.</li> <li>• Turn ignition key to ON (engine OFF).</li> <li>• Measure voltage between neutral switch terminal A (harness-side) and body ground.</li> <li>• Is voltage <b>below 1.0 V</b>?</li> </ul>	Yes	Repair or replace harness for open, then go to Step 9.
		No	Go to next step.
8	<b>INSPECT NEUTRAL SWITCH SIGNAL CIRCUIT FOR OPEN CIRCUIT</b> <ul style="list-style-type: none"> <li>• Turn ignition key to OFF.</li> <li>• Connect breakout box with PCM connector disconnected.</li> <li>• Turn ignition key to ON (engine OFF).</li> <li>• Depress clutch pedal and measure voltage between breakout box terminal 64 and body ground.</li> <li>• Is voltage <b>below 1.0 V</b>?</li> </ul>	Yes	Go to next step.
		No	Repair or replace harness for open, then go to Step 9.
9	<b>VERIFY TROUBLESHOOTING OF DTC P0705 COMPLETED</b> <ul style="list-style-type: none"> <li>• Make sure to reconnect all disconnected connectors.</li> <li>• Start engine.</li> <li>• Clear DTC from PCM memory using WDS or equivalent.</li> <li>• Drive vehicle <b>above 29.8 km/h {18.5 mph}</b> and stop vehicle.</li> <li>• Depress and release clutch pedal <b>more than 10 times</b> during drive cycle.</li> <li>• Is same DTC present?</li> </ul>	Yes	Replace PCM, then go to next step.
		No	Go to next step.
10	<b>VERIFY AFTER REPAIR PROCEDURE</b> <ul style="list-style-type: none"> <li>• Perform "After Repair Procedure". (See 01-02A-10 AFTER REPAIR PROCEDURE [ZM].)</li> <li>• Is there any DTC present?</li> </ul>	Yes	Go to applicable DTC inspection. (See 01-02A-15 DTC TABLE [ZM].)
		No	Troubleshooting completed.

01-02A

# ON-BOARD DIAGNOSTIC [ENGINE CONTROL SYSTEM (ZM)]

## DTC P1102 [ZM]

A3U010201083W17

<b>DTC P1102</b>	<b>MAF sensor inconsistent with TP sensor (lower than expected)</b>
<b>DETECTION CONDITION</b>	<ul style="list-style-type: none"> <li>PCM compares actual input signal from MAF sensor with expected input signal from MAF sensor which PCM calculates by input voltage from TP sensor. If mass intake air flow amount is <b>below 4.8 g/s {0.63 lb/min}</b> for <b>5 seconds</b> and throttle opening angle is <b>above 50%</b> with engine running, PCM determines that detected mass intake air flow amount is too low.</li> </ul> <p><b>Diagnostic support note</b></p> <ul style="list-style-type: none"> <li>This is a continuous monitor (CCM).</li> <li>MIL illuminates if PCM detects the above malfunction condition in two consecutive drive cycles.</li> <li>PENDING CODE is available if PCM detects the above malfunction condition during first drive cycle.</li> <li>FREEZE FRAME DATA is available.</li> <li>DTC is stored in PCM memory.</li> </ul>
<b>POSSIBLE CAUSE</b>	<ul style="list-style-type: none"> <li>MAF sensor malfunction</li> <li>TP sensor malfunction</li> <li>Electrical corrosion in MAF signal circuit</li> <li>Voltage drops in MAF signal circuit</li> </ul>

### Diagnostic procedure

STEP	INSPECTION		ACTION
1	<b>VERIFY FREEZE FRAME DATA HAS BEEN RECORDED</b> <ul style="list-style-type: none"> <li>Has FREEZE FRAME DATA been recorded?</li> </ul>	Yes	Go to next step.
		No	Record FREEZE FRAME DATA on repair order, then go to next step.
2	<b>VERIFY RELATED REPAIR INFORMATION AVAILABILITY</b> <ul style="list-style-type: none"> <li>Check for related Service Bulletins availability.</li> <li>Is any related repair information available?</li> </ul>	Yes	Perform repair or diagnosis according to available repair information. <ul style="list-style-type: none"> <li>If vehicle is not repaired, go to next step.</li> </ul>
		No	Go to next step.
3	<b>VERIFY CURRENT INPUT SIGNAL STATUS-IS CONCERN INTERMITTENT OR CONSTANT</b> <ul style="list-style-type: none"> <li>Connect WDS or equivalent to DLC-2.</li> <li>Start the engine.</li> <li>Access ECT, TP and MAF PIDs.</li> <li>Warm up the engine until ECT PID is <b>above 80°C {176°F}</b>.</li> <li>Drive the vehicle.</li> <li>Read MAF PID while TP PID is <b>above 50%</b>.</li> <li>Is MAF PID reading <b>below 4.8 g/s {0.63 lb/min}</b>?</li> </ul>	Yes	Make sure that TP sensor resistance changes smoothly while gradually opening throttle valve. <ul style="list-style-type: none"> <li>If not, replace TP sensor and go to Step 6.</li> <li>For others, go to next step.</li> </ul>
		No	Intermittent concern exists. Go to INTERMITTENT CONCERN TROUBLESHOOTING procedure. (See 01-03A-4 INTERMITTENT CONCERN TROUBLESHOOTING [ZM].)
4	<b>INSPECT MAF SENSOR CONNECTOR FOR POOR CONNECTION</b> <ul style="list-style-type: none"> <li>Turn ignition key to OFF.</li> <li>Disconnect MAF/IAT sensor connector.</li> <li>Check for poor connection (damaged/pulled-out terminals, corrosion, etc.).</li> <li>Is there malfunction?</li> </ul>	Yes	Repair or replace suspected terminal or MAF/IAT sensor, then go to Step 6.
		No	Go to next step.
5	<b>INSPECT PCM CONNECTOR FOR POOR CONNECTION</b> <ul style="list-style-type: none"> <li>Disconnect PCM connector.</li> <li>Check for poor connection (damaged/pulled-out pins, corrosion, etc.).</li> <li>Is there malfunction?</li> </ul>	Yes	Repair terminal, then go to next step.
		No	Replace MAF/IAT sensor, then go to next step.



## ON-BOARD DIAGNOSTIC [ENGINE CONTROL SYSTEM (ZM)]

01-02A

STEP	INSPECTION		ACTION
6	<b>VERIFY TROUBLESHOOTING OF DTC P1102 COMPLETED</b> <ul style="list-style-type: none"> <li>Make sure to reconnect all disconnected connectors.</li> <li>Turn ignition key to ON (Engine OFF).</li> <li>Clear DTC from memory using WDS or equivalent generic OBD-II function.</li> <li>Start the engine.</li> <li>Access ECT, TP and MAF PIDs using WDS or equivalent.</li> <li>Warm up the engine until ECT PID is reading <b>above 80°C {176°F}</b>.</li> <li>Drive the vehicle and read TP and MAF PIDs.</li> </ul> <p><b>Note</b></p> <ul style="list-style-type: none"> <li>Verify PIDs reading are within specifications <b>more than 5 seconds</b>.                             <ul style="list-style-type: none"> <li>— MAF PID: <b>above 4.8 g/s {0.63 lb/min.}</b></li> <li>— TP PID: <b>above 50%</b></li> </ul> </li> </ul> <ul style="list-style-type: none"> <li>Is PENDING CODE of same DTC present?</li> </ul>	Yes	Replace PCM, then go to next step.
		No	Go to next step.
7	<b>VERIFY AFTER REPAIR PROCEDURE</b> <ul style="list-style-type: none"> <li>Perform "After Repair Procedure". (See 01-02A-10 AFTER REPAIR PROCEDURE [ZM].)</li> <li>Is there any DTC present?</li> </ul>	Yes	Go to applicable DTC inspection. (See 01-02A-15 DTC TABLE [ZM].)
		No	Troubleshooting completed.

### DTC P1103 [ZM]

A3U010201083W18

DTC P1103	Mass air flow sensor inconsistent with engine speed (greater than expected)
<b>DETECTION CONDITION</b>	<ul style="list-style-type: none"> <li>PCM compares actual input signal from MAF sensor with expected input signal from MAF sensor which PCM calculates by engine speed. If mass intake air flow amount is <b>above 66.6 g/s {8.79 lb/min}</b> for <b>5 seconds</b> and engine speed is <b>less than 2,000 rpm</b> with engine running, PCM determines that detected mass intake air flow amount is too high.</li> </ul> <p><b>Diagnostic support note</b></p> <ul style="list-style-type: none"> <li>This is a continuous monitor (CCM).</li> <li>MIL illuminates if PCM detects the above malfunction condition in two consecutive drive cycles.</li> <li>PENDING CODE is available if PCM detects the above malfunction condition during first drive cycle.</li> <li>FREEZE FRAME DATA is available.</li> <li>DTC is stored in PCM memory.</li> </ul>
<b>POSSIBLE CAUSE</b>	<ul style="list-style-type: none"> <li>MAF sensor malfunction</li> <li>Electrical corrosion in MAF RETURN circuit</li> <li>Voltage drops in ground circuit</li> </ul>

### Diagnostic procedure

STEP	INSPECTION		ACTION
1	<b>VERIFY FREEZE FRAME DATA HAS BEEN RECORDED</b> <ul style="list-style-type: none"> <li>Has FREEZE FRAME DATA been recorded?</li> </ul>	Yes	Go to next step.
		No	Record FREEZE FRAME DATA on repair order, then go to next step.
2	<b>VERIFY RELATED REPAIR INFORMATION AVAILABILITY</b> <ul style="list-style-type: none"> <li>Check for related Service Bulletins availability.</li> <li>Is any related repair information available?</li> </ul>	Yes	Perform repair or diagnosis according to available repair information. <ul style="list-style-type: none"> <li>If vehicle is not repaired, go to next step.</li> </ul>
		No	Go to next step.

## ON-BOARD DIAGNOSTIC [ENGINE CONTROL SYSTEM (ZM)]

STEP	INSPECTION	ACTION	
3	<b>VERIFY CURRENT INPUT SIGNAL STATUS-IS CONCERN INTERMITTENT OR CONSTANT</b> <ul style="list-style-type: none"> <li>• Connect WDS or equivalent to DLC-2.</li> <li>• Start the engine.</li> <li>• Access ECT, MAF and RPM PIDs using WDS or equivalent.</li> <li>• Warm up engine until ECT PID is <b>above 80 °C {176 °F}</b>.</li> <li>• Read MAF PID while RPM PID is <b>below 2,000 rpm</b>.</li> <li>• Is MAF PID reading <b>above 66.6 g/s {8.79 lb/min}</b>?</li> </ul>	Yes	Go to next step.
		No	Intermittent concern exists. Go to INTERMITTENT CONCERN TROUBLESHOOTING procedure. (See 01-03A-4 INTERMITTENT CONCERN TROUBLESHOOTING [ZM].)
4	<b>CHECK MAF SENSOR TERMINALS FOR ELECTRICAL CORROSION</b> <ul style="list-style-type: none"> <li>• Turn ignition key to OFF.</li> <li>• Disconnect MAF/IAT sensor connector.</li> <li>• Check for poor connection (damaged/pulled-out terminals, corrosion, etc.).</li> <li>• Is any problem corrosion found?</li> </ul>	Yes	Repair or replace suspected terminal or MAF/IAT sensor, then go to Step 6.
		No	Go to next step.
5	<b>INSPECT PCM CONNECTOR FOR POOR CONNECTION</b> <ul style="list-style-type: none"> <li>• Disconnect PCM connector.</li> <li>• Check for poor connection (damaged/pulled-out pins, corrosion, etc.).</li> <li>• Is there malfunction?</li> </ul>	Yes	Repair terminal, then go to next step.
		No	Go to next step.
6	<b>VERIFY TROUBLESHOOTING OF DTC P1103 COMPLETED</b> <ul style="list-style-type: none"> <li>• Make sure to reconnect all disconnected connectors.</li> <li>• Turn ignition key to ON (Engine OFF).</li> <li>• Clear DTC from memory using WDS or equivalent generic OBD-II function.</li> <li>• Start the engine.</li> <li>• Warm up engine until ECT PID is <b>above 80 °C {176 °F}</b>.</li> <li>• Read MAF and RPM PIDs.</li> </ul> <p><b>Note</b></p> <ul style="list-style-type: none"> <li>• MAF PID should indicate <b>below 66.6 g/s {8.79 lb/min}</b> while RPM PID is <b>below 2,000 rpm</b>.</li> </ul> <ul style="list-style-type: none"> <li>• Is pending code of same DTC present?</li> </ul>	Yes	Replace PCM, then go to next step.
		No	Go to next step.
7	<b>VERIFY AFTER REPAIR PROCEDURE</b> <ul style="list-style-type: none"> <li>• Perform "After Repair Procedure". (See 01-02A-10 AFTER REPAIR PROCEDURE [ZM].)</li> <li>• Is there any DTC present?</li> </ul>	Yes	Go to applicable DTC inspection. (See 01-02A-15 DTC TABLE [ZM].)
		No	Troubleshooting completed.

### DTC P1122 [ZM]

A3U010201083W19

DTC P1122	Throttle position stuck closed (lower than expected)
<b>DETECTION CONDITION</b>	<ul style="list-style-type: none"> <li>• If PCM detects that throttle valve opening angle is <b>below 12.5%</b> for <b>5 seconds</b> after following conditions are met, PCM determines that TP is stuck closed:</li> </ul> <p><b>MONITORING CONDITIONS</b></p> <ul style="list-style-type: none"> <li>— Engine coolant temperature is <b>above 80 °C {176 °F}</b>.</li> <li>— MAF sensor signal is <b>above 58.3 g/s {7.7 lb/min}</b>.</li> </ul> <p><b>Diagnostic support note</b></p> <ul style="list-style-type: none"> <li>• This is a continuous monitor (CCM).</li> <li>• MIL illuminates if PCM detects the above malfunction conditions in two consecutive drive cycles.</li> <li>• PENDING CODE is available if PCM detects the above malfunction condition during first drive cycle.</li> <li>• FREEZE FRAME DATA is available.</li> <li>• DTC is stored in PCM memory.</li> </ul>

## ON-BOARD DIAGNOSTIC [ENGINE CONTROL SYSTEM (ZM)]

<b>DTC P1122</b>	<b>Throttle position stuck closed (lower than expected)</b>
<b>POSSIBLE CAUSE</b>	<ul style="list-style-type: none"> <li>• TP sensor malfunction</li> <li>• Electrical corrosion in TP signal circuit</li> <li>• Voltage drops in reference voltage (vref) supply circuit</li> <li>• PCM malfunction</li> </ul>

### Diagnostic procedure

STEP	INSPECTION		ACTION
1	<b>VERIFY FREEZE FRAME DATA HAS BEEN RECORDED</b> • Has FREEZE FRAME DATA been recorded?	Yes	Go to next step.
		No	Record FREEZE FRAME DATA on repair order, then go to next step.
2	<b>VERIFY RELATED PENDING CODE OR STORED DTC</b> • Turn ignition key to ON (Engine OFF). • Retrieve pending or stored DTCs using WDS or equivalent. • Is DTC P1103 also retrieved?	Yes	Go to DTC P1103 troubleshooting procedure.
		No	Go to next step.
3	<b>VERIFY RELATED REPAIR INFORMATION AVAILABILITY</b> • Check for related Service Bulletins availability. • Is any related repair information available?	Yes	Perform repair or diagnosis according to available repair information. • If vehicle is not repaired, go to next step.
		No	Go to next step.
4	<b>VERIFY CURRENT INPUT SIGNAL STATUS - IS CONCERN INTERMITTENT OR CONSTANT</b> • Start the engine. • Access ECT, TP and MAF PIDs using WDS or equivalent. • Warm up the engine until ECT PID is <b>above 80 °C {176 °F}</b> . • Drive the vehicle. • Read TP PID while MAF PID is <b>above 58.3 g/s {7.7 lb/min}</b> . • Is TP PID reading <b>above 12.5%</b> ?	Yes	Go to next step.
		No	Intermittent concern exists. Go to INTERMITTENT CONCERN TROUBLESHOOTING procedure. (See 01-03A-4 INTERMITTENT CONCERN TROUBLESHOOTING [ZM].)
5	<b>CHECK TP SENSOR TERMINALS FOR ELECTRICAL CORROSION</b> • Turn ignition key to OFF. • Disconnect TP sensor connector. • Check for electrical corrosion on male and female TP sensor terminals. • Is any electrical corrosion found?	Yes	Repair or replace suspected terminal or TP sensor, then go to Step 8.
		No	Go to next step.
6	<b>VERIFY TP SENSOR</b> • Does TP sensor resistance smoothly change while gradually opening throttle valve?	Yes	Go to next step.
		No	Replace TP sensor, then go to Step 8.
7	<b>CHECK PCM TERMINALS FOR ELECTRICAL CORROSION</b> • Disconnect PCM connector. • Check for electrical corrosion on PCM male and female terminals at 89, 90 and 91. • Is any electrical corrosion found?	Yes	Repair terminal, then go to Step 8.
		No	Go to next step.
8	<b>VERIFY TROUBLESHOOTING OF DTC P1122 COMPLETED</b> • Make sure to reconnect all disconnected connectors. • Start the engine. • Clear DTC from PCM memory using WDS or equivalent generic OBD-II function. • Access ECT, TP and MAF PIDs using WDS or equivalent. • Warm up the engine until ECT PID is reading <b>above 80 °C {176°F}</b> . • Drive the vehicle and read TP and MAF PIDs. • Verify PID readings are within specifications MAF PID: <b>above 58.3 g/s {7.7 lb/min}</b> TP PID: <b>above 12.5% more than 5 seconds</b> • Is pending code of same DTC present?	Yes	Replace PCM, then go to next step.
		No	Go to next step.

01-02A

## ON-BOARD DIAGNOSTIC [ENGINE CONTROL SYSTEM (ZM)]

STEP	INSPECTION	ACTION	
9	<b>VERIFY AFTER REPAIR PROCEDURE</b> <ul style="list-style-type: none"> <li>• Perform "After Repair Procedure". (See 01-02A-10 AFTER REPAIR PROCEDURE [ZM].)</li> <li>• Is there any DTC present?</li> </ul>	Yes	Go to applicable DTC inspection. (See 01-02A-15 DTC TABLE [ZM].)
		No	Troubleshooting completed.

### DTC P1123 [ZM]

A3U010201083W20

DTC P1123	Throttle position stuck open (higher than expected)
<b>DETECTION CONDITION</b>	<ul style="list-style-type: none"> <li>• If PCM detects that throttle valve opening angle is <b>above 50%</b> for <b>5 seconds</b> after following conditions are met, PCM determines that TP is stuck open:  <b>MONITORING CONDITIONS</b> <ul style="list-style-type: none"> <li>— Engine speed is <b>above 500 rpm</b>.</li> <li>— MAF sensor signal is <b>below 4.8 g/s {0.6 lb/min}</b>.</li> </ul> </li> </ul> <b>Diagnostic support note</b> <ul style="list-style-type: none"> <li>• This is a continuous monitor (CCM).</li> <li>• MIL illuminates if PCM detects the above malfunction conditions in two consecutive drive cycles.</li> <li>• PENDING CODE is available if PCM detects the above malfunction condition during first drive cycle.</li> <li>• FREEZE FRAME DATA is available.</li> <li>• DTC is stored in PCM memory.</li> </ul>
<b>POSSIBLE CAUSE</b>	<ul style="list-style-type: none"> <li>• TP sensor malfunction</li> <li>• MAF sensor malfunction</li> <li>• Electrical corrosion in TP signal circuit</li> <li>• Voltage drops in ground circuit</li> <li>• PCM malfunction</li> </ul>

### Diagnostic procedure

STEP	INSPECTION	ACTION	
1	<b>VERIFY FREEZE FRAME DATA HAS BEEN RECORDED</b> <ul style="list-style-type: none"> <li>• Has FREEZE FRAME DATA been recorded?</li> </ul>	Yes	Go to next step.
		No	Record FREEZE FRAME DATA on repair order, then go to next step.
2	<b>VERIFY RELATED REPAIR INFORMATION AVAILABILITY</b> <ul style="list-style-type: none"> <li>• Check for related Service Bulletins availability.</li> <li>• Is any related repair information available?</li> </ul>	Yes	Perform repair or diagnosis according to available repair information. <ul style="list-style-type: none"> <li>• If vehicle is not repaired, go to next step.</li> </ul>
		No	Go to next step.
3	<b>VERIFY TP PID</b> <ul style="list-style-type: none"> <li>• Clear DTC from PCM memory using WDS or equivalent generic OBD II function.</li> <li>• Start engine.</li> <li>• Access TP, MAF and RPM PIDs using WDS or equivalent.</li> <li>• Read TP PID while MAF PID is <b>below 4.8g/s {0.6 lb/min}</b> and RPM PID is <b>above 500 rpm</b>.</li> <li>• Is TP PID reading <b>above 50%</b>?</li> </ul>	Yes	Go to Step 5.
		No	Go to next step.
4	<b>VERIFY CURRENT INPUT SIGNAL STATUS - IS CONCERN INTERMITTENT OR CONSTANT</b> <ul style="list-style-type: none"> <li>• Drive the vehicle and read MAF PID.</li> <li>• Does MAF PID change in compliance with driving condition?</li> </ul>	Yes	Intermittent concern exists. Go to INTERMITTENT CONCERN troubleshooting procedure.
		No	Check MAF sensor and related circuits and terminals. (See 01-40A-26 MASS AIR FLOW (MAF)/INTAKE AIR TEMPERATURE (IAT) SENSOR INSPECTION [ZM].) Repair or replace as necessary, then go to Step 9.
5	<b>CHECK TP SENSOR TERMINALS FOR ELECTRICAL CORROSION</b> <ul style="list-style-type: none"> <li>• Turn ignition key to OFF.</li> <li>• Disconnect TP sensor connector.</li> <li>• Check for electrical corrosion on male and female TP sensor terminals.</li> <li>• Is any electrical corrosion found?</li> </ul>	Yes	Repair or replace suspected terminal or TP sensor, then go to Step 9.
		No	Go to next step.
6	<b>CHECK GROUND CIRCUIT FOR VOLTAGE DROP</b> <ul style="list-style-type: none"> <li>• Check resistance between TP sensor terminal B (harness-side) and body ground.</li> <li>• Does resistance read <b>approx. 0 ohm</b>?</li> </ul>	Yes	Go to next step.
		No	Repair or replace rusted or corroded PCM terminal 91 (harness-side). Disconnect breakout box and go to Step 9.

## ON-BOARD DIAGNOSTIC [ENGINE CONTROL SYSTEM (ZM)]

STEP	INSPECTION	ACTION
7	<b>INSPECT TP SENSOR</b> <ul style="list-style-type: none"> <li>• Check resistance between TP sensor terminals A and C (part-side).</li> <li>• Does resistance smoothly change while gradually opening throttle valve?</li> </ul>	Yes Go to next step.
		No Replace TP sensor, then go to Step 9.
8	<b>CHECK PCM TERMINALS FOR ELECTRICAL CORROSION</b> <ul style="list-style-type: none"> <li>• Disconnect PCM connector.</li> <li>• Check for electrical corrosion on PCM and PCM connector male and female terminals.</li> <li>• Is any electrical corrosion found?</li> </ul>	Yes Repair terminal, then go to next step.
		No Go to next step.
9	<b>VERIFY TROUBLESHOOTING OF DTC P1123 COMPLETED</b> <ul style="list-style-type: none"> <li>• Make sure to reconnect all disconnected connectors.</li> <li>• Start engine.</li> <li>• Clear DTC from PCM memory using WDS or equivalent generic OBD-II function.</li> <li>• Access RPM, TP and MAF PIDs using WDS or equivalent.</li> <li>• Verify TP PID is reading <b>below 50%</b> while MAF PID is <b>below 4.8 g/s {0.63 lb/min}</b> and RPM PID is <b>above 500 rpm</b>.</li> <li>• Is pending code of same DTC present?</li> </ul>	Yes Replace PCM, then go to next step.
		No Go to next step.
10	<b>VERIFY AFTER REPAIR PROCEDURE</b> <ul style="list-style-type: none"> <li>• Perform "After Repair Procedure". (See 01-02A-10 AFTER REPAIR PROCEDURE [ZM].)</li> <li>• Is there any DTC present?</li> </ul>	Yes Go to applicable DTC inspection. (See 01-02A-15 DTC TABLE [ZM].)
		No Troubleshooting completed.

01-02A

### DTC P1170 [ZM]

A3U010201083W21

DTC P1170	HO2S (front) no inversion
<b>DETECTION CONDITION</b>	<ul style="list-style-type: none"> <li>• PCM monitors input voltage from HO2S (front) when the following monitoring conditions are met. If input voltage from sensor remains <b>below or above 0.45 V</b> for <b>42.9 s</b>, PCM determines that there is no HO2S (front, RH) inversion.</li> </ul> <p><b>MONITORING CONDITIONS</b></p> <ul style="list-style-type: none"> <li>— Engine speed is <b>above 1,500 rpm</b>.</li> <li>— Engine coolant temperature is <b>above 80 °C {176 °F}</b>.</li> </ul> <p><b>Diagnostic support note</b></p> <ul style="list-style-type: none"> <li>• This is a continuous monitor (CCM).</li> <li>• MIL illuminates if PCM detects the above malfunction condition in two consecutive drive cycles.</li> <li>• PENDING CODE is available if PCM detects the above malfunction condition during first drive cycle.</li> <li>• FREEZE FRAME DATA is available.</li> <li>• DTC is stored in PCM memory.</li> </ul>
<b>POSSIBLE CAUSE</b>	<ul style="list-style-type: none"> <li>• HO2S (front) malfunction</li> <li>• HO2S (front) heater malfunction</li> <li>• Fuel injector malfunction</li> <li>• Pressure regulator malfunction</li> <li>• Fuel pump malfunction</li> <li>• Fuel delivery hose clogging or leakage</li> <li>• Fuel filter clogging</li> <li>• Fuel return hose clogging or leakage</li> <li>• Air suction or leakage</li> <li>• PCV valve malfunction</li> <li>• Purge solenoid valve malfunction</li> <li>• Purge solenoid hoses are hooked up incorrectly.</li> <li>• Ignition coil malfunction</li> <li>• Insufficient compression</li> <li>• Engine malfunction</li> </ul>

## ON-BOARD DIAGNOSTIC [ENGINE CONTROL SYSTEM (ZM)]

### Diagnostic procedure

STEP	INSPECTION	ACTION	
1	<b>VERIFY FREEZE FRAME DATA HAS BEEN RECORDED</b> <ul style="list-style-type: none"> <li>• Has FREEZE FRAME DATA been recorded?</li> </ul>	Yes	Go to next step.
		No	Record FREEZE FRAME DATA on repair order, then go to next step.
2	<b>VERIFY RELATED REPAIR INFORMATION AVAILABILITY</b> <ul style="list-style-type: none"> <li>• Check for related Service Bulletins availability.</li> <li>• Is any related repair information available?</li> </ul>	Yes	Perform repair or diagnosis according to available repair information. <ul style="list-style-type: none"> <li>• If vehicle is not repaired, go to next step.</li> </ul>
		No	Go to next step.
3	<b>VERIFY RELATED PENDING AND STORED DTCs</b> <ul style="list-style-type: none"> <li>• Turn ignition key to OFF, then start engine.</li> <li>• Verify pending and stored DTCs using WDS or equivalent.</li> <li>• Are other DTCs present?</li> </ul>	Yes	Go to appropriate DTC troubleshooting procedures.
		No	Go to next step.
4	<b>IDENTIFY TRIGGER DTC FOR FREEZE FRAME DATA</b> <ul style="list-style-type: none"> <li>• Is DTC P1170 on FREEZE FRAME DATA?</li> </ul>	Yes	Go to next step.
		No	Go to troubleshooting procedures for DTC on FREEZE FRAME DATA.
5	<b>VERIFY CURRENT INPUT SIGNAL STATUS IS CONCERN INTERMITTENT OR CONSTANT</b> <ul style="list-style-type: none"> <li>• Warm up engine.</li> <li>• Access O2S11 PID using WDS or equivalent.</li> <li>• Verify PID while racing engine (in PARK).</li> <li>• Is PID reading okay?                             <ul style="list-style-type: none"> <li>— <b>More than 0.45 V</b> when suddenly depressing accelerator pedal (rich condition)</li> <li>— <b>Less than 0.45 V</b> just after release of accelerator pedal (lean condition)</li> </ul> </li> </ul>	Yes	Go to next step.
		No	Replace HO2S (front), then go to Step 21.
6	<b>INSPECT LONG TERM FUEL TRIM</b> <ul style="list-style-type: none"> <li>• Access LONGFT1 PID using WDS or equivalent.</li> <li>• Compare it with FREEZE FRAME DATA recorded at Step 1.</li> <li>• Is it decreased?</li> </ul>	Yes	Engine is driven under rich condition. Go to next step.
		No	Engine is driven under lean condition. Go to Step 10.
7	<b>INSPECT FUEL LINE PRESSURE (EXCESSIVE FUEL LINE PRESSURE)</b> <ul style="list-style-type: none"> <li>• Turn ignition key to OFF.</li> <li>• Inspect fuel line pressure. (See 01-14-6 FUEL PRESSURE INSPECTION.)</li> <li>• Is fuel line pressure <b>more than 150 kPa {1.5 kgf/cm<sup>2</sup>, 22 psi}</b>?</li> </ul>	Yes	Go to Step 9.
		No	Go to next step.
8	<b>VERIFY VACUUM IS LEADING TO PRESSURE REGULATOR</b> <ul style="list-style-type: none"> <li>• Disconnect vacuum hose from pressure regulator.</li> <li>• Verify that vacuum is felt at opening port of disconnected vacuum hose.</li> <li>• Is vacuum felt?</li> </ul>	Yes	Inspect following parts and repair or replace if necessary: <ul style="list-style-type: none"> <li>• Fuel pump maximum pressure</li> <li>• Fuel return pipe for clogging                             <ul style="list-style-type: none"> <li>— If all items above are okay, replace pressure regulator. Then, go to Step 21.</li> </ul> </li> </ul>
		No	Verify vacuum hoses are connected correctly. <ul style="list-style-type: none"> <li>• If okay, replace PRC solenoid valve. Then go to Step 21.</li> <li>• If not, reconnect vacuum hoses to correct position. Then go to Step 21.</li> </ul>
9	<b>INSPECT PURGE SOLENOID VALVE FOR WHETHER STUCK OPEN</b> <ul style="list-style-type: none"> <li>• Turn ignition key to OFF.</li> <li>• Disconnect both hoses from purge solenoid valve.</li> <li>• Blow air through purge solenoid valve.</li> <li>• Does air blow through?</li> </ul>	Yes	Replace purge solenoid valve. Go to Step 21.
		No	Go to Step 14.
10	<b>INSPECT PCV VALVE OPERATION</b> <ul style="list-style-type: none"> <li>• Inspect PCV valve operation. (See 01-16-18 POSITIVE CRANKCASE VENTILATION (PCV) VALVE INSPECTION.)</li> <li>• Is PCV valve okay?</li> </ul>	Yes	Go to next step.
		No	Replace PCV, then go to Step 21.

## ON-BOARD DIAGNOSTIC [ENGINE CONTROL SYSTEM (ZM)]

STEP	INSPECTION	ACTION	
11	<b>INSPECT FUEL LINE PRESSURE (LOW FUEL LINE PRESSURE)</b> <ul style="list-style-type: none"> <li>• Turn ignition key to OFF.</li> <li>• Inspect fuel line pressure. (See 01-14-6 FUEL PRESSURE INSPECTION.)</li> <li>• Is fuel line pressure <b>more than 150 kPa {1.5 kgf/cm<sup>2</sup>, 22 psi}</b>?</li> </ul>	Yes	Go to Step 14.
		No	Go to next step.
12	<b>INSPECT FUEL PUMP MAXIMUM PRESSURE</b> <ul style="list-style-type: none"> <li>• Stop engine.</li> <li>• Turn ignition key to ON (Engine OFF).</li> <li>• Perform fuel pump maximum pressure test. (See 01-14-17 Fuel Pump Maximum Pressure Inspection.)</li> <li>• Is fuel pump maximum pressure <b>within 450—630 kPa {4.5—6.5 kgf/cm<sup>2</sup>, 64—92 psi}</b>?</li> </ul>	Yes	Go to next step.
		No	Inspect fuel pump circuit for open or poor connection. <ul style="list-style-type: none"> <li>• Repair or replace suspected circuit.</li> <li>• If circuit is okay, replace fuel pump. Then go to Step 21.</li> </ul>
13	<b>INSPECT FUEL LINE FROM FUEL PUMP TO FUEL DELIVERY PUMP</b> <ul style="list-style-type: none"> <li>• Visually inspect fuel line for any leakage.</li> <li>• Is any fuel leakage found?</li> </ul>	Yes	Replace suspected fuel line, then go to Step 21.
		No	Inspect fuel filters for following: <ul style="list-style-type: none"> <li>• Restriction or clogging at fuel filter (high-pressure)</li> <li>• Foreign material or stain inside fuel filter (low-pressure)                             <ul style="list-style-type: none"> <li>— If restriction or clogging is found at fuel filter (high-pressure), replace fuel filter (high-pressure).</li> <li>— If foreign material or stain is found inside fuel filter (low-pressure), clean fuel tank and fuel filter (low-pressure).</li> <li>— If all items above are okay, replace pressure regulator. Then, go to Step 21.</li> </ul> </li> </ul>
14	<b>CHECK IGNITION COIL OPERATION AND HIGH-TENSION LEAD WITH TIMING LIGHT</b> <ul style="list-style-type: none"> <li>• Verify blinking condition on each cylinder using timing light at idle.</li> <li>• Do all cylinders show blinking condition?</li> </ul>	Yes	Go to Step 18.
		No	Go to next step.
15	<b>CHECK HIGH-TENSION LEADS OF NON-BLINKING CYLINDER</b> <ul style="list-style-type: none"> <li>• Turn ignition key to OFF.</li> <li>• Inspect high-tension leads for installation condition, corrosion on terminal, open lead and damaged cover.</li> <li>• Is condition of high-tension lead okay?</li> </ul>	Yes	Go to next step.
		No	Replace faulty high-tension lead, then go to Step 21.
16	<b>INSPECT POWER SUPPLY TERMINAL AT IGNITION COIL CONNECTOR</b> <ul style="list-style-type: none"> <li>• Disconnect ignition coil connector.</li> <li>• Turn ignition key to ON (Engine OFF).</li> <li>• Measure voltage between ignition coil connector terminal D (harness-side) and body ground.</li> <li>• Is voltage reading <b>B+</b>?</li> </ul>	Yes	Go to next step.
		No	Check for open circuit between ignition coil connector and ignition switch. Repair or replace wiring harness, then go to Step 21.
17	<b>INSPECT IGNITION COIL RESISTANCE</b> <ul style="list-style-type: none"> <li>• Check ignition coil resistance. (See 01-18-2 IGNITION COIL INSPECTION.)</li> <li>• Is coil resistance okay?</li> </ul>	Yes	Go to next step.
		No	Replace ignition coil, then go to Step 21.
18	<b>INSPECT ENGINE COMPRESSION</b> <ul style="list-style-type: none"> <li>• Inspect engine compression. (See 01-10A-8 COMPRESSION INSPECTION [ZM].)</li> <li>• Is it okay?</li> </ul>	Yes	Go to next step.
		No	Implement engine overhaul for repairs, then go to next step.
19	<b>INSPECT FUEL INJECTOR OPERATION</b> <ul style="list-style-type: none"> <li>• Turn ignition key to OFF.</li> <li>• Inspect injector. (See 01-14-24 FUEL INJECTOR INSPECTION.)</li> <li>• Is injector okay?</li> </ul>	Yes	Go to next step.
		No	Replace injector, then go to Step 21.

01-02A

## ON-BOARD DIAGNOSTIC [ENGINE CONTROL SYSTEM (ZM)]

STEP	INSPECTION	ACTION	
20	<b>INSPECT SEALING OF ENGINE COOLANT PASSAGE</b>  <b>Warning</b> <ul style="list-style-type: none"> <li>• Removing radiator cap when radiator is hot is dangerous. Scalding coolant and steam may shoot out and cause serious injury.</li> <li>• When removing radiator cap, wrap a thick cloth around and turn it slowly.</li> </ul> <ul style="list-style-type: none"> <li>• Remove radiator cap.</li> <li>• Implement procedure to bleed air from engine coolant, then run engine at idle.</li> <li>• Is there any small bubble which makes engine coolant white at filling opening?</li> </ul> <b>Note</b> <ul style="list-style-type: none"> <li>• Large bubbles are normal since they are remaining air coming out from engine coolant passage.</li> </ul>	Yes	Air gets in from poor sealing to head gasket or other areas between combustion chamber and engine coolant passage. Repair or replace faulty parts, then go to next step.
		No	Go to next step.
21	<b>VERIFY TROUBLESHOOTING OF DTC P1170 COMPLETED</b> <ul style="list-style-type: none"> <li>• Make sure to reconnect all disconnected connectors.</li> <li>• Turn ignition key to ON (Engine OFF).</li> <li>• Clear DTC from memory using WDS or equivalent.</li> <li>• Start engine.</li> <li>• Access ECT and RPM PIDs using WDS or equivalent.</li> <li>• Make sure that ECT PID is <b>above 80 °C {176 °F}</b>.</li> <li>• Increase and keep engine speed <b>above 1,500 rpm</b> for at <b>least 1 minute</b>.</li> <li>• Is pending code of same DTC present?</li> </ul>	Yes	Replace or reprogram PCM. Then go to next step.
		No	Go to next step.
22	<b>VERIFY AFTER REPAIR PROCEDURE</b> <ul style="list-style-type: none"> <li>• Perform "After Repair Procedure". (See 01-02A-10 AFTER REPAIR PROCEDURE [ZM].)</li> <li>• Is there any DTC present?</li> </ul>	Yes	Go to applicable DTC inspection. (See 01-02A-15 DTC TABLE [ZM].)
		No	Troubleshooting completed.

### DTC P1250 [ZM]

A3U010201083W22

DTC P1250	Pressure regulator control (PRC) valve circuit malfunction
<b>DETECTION CONDITION</b>	<ul style="list-style-type: none"> <li>• PCM monitors input voltages from PRC solenoid valve. If voltage at PCM terminal 95 remains low or high, PCM determines that PRC solenoid valve circuit has malfunction.</li> </ul> <b>Diagnostic support note</b> <ul style="list-style-type: none"> <li>• This is a continuous monitor (CCM).</li> <li>• PCM detects the above malfunction condition in two consecutive drive cycles.</li> <li>• PENDING CODE is available if PCM detects the above malfunction condition during first drive cycle.</li> <li>• FREEZE FRAME DATA is available.</li> <li>• DTC is stored in PCM memory.</li> </ul>
<b>POSSIBLE CAUSE</b>	<ul style="list-style-type: none"> <li>• PRC solenoid valve malfunction</li> <li>• Connector or terminal malfunction</li> <li>• Short to ground in wiring between PRC solenoid valve terminal B and PCM terminal 95</li> <li>• Open circuit in wiring between main relay terminal D and PRC solenoid valve terminal A</li> <li>• Open circuit in wiring between PRC solenoid valve terminal B and PCM terminal 95</li> <li>• Short to power circuit between PRC solenoid valve terminal B and PCM terminal 95</li> <li>• PCM malfunction</li> </ul>



# ON-BOARD DIAGNOSTIC [ENGINE CONTROL SYSTEM (ZM)]

01-02A

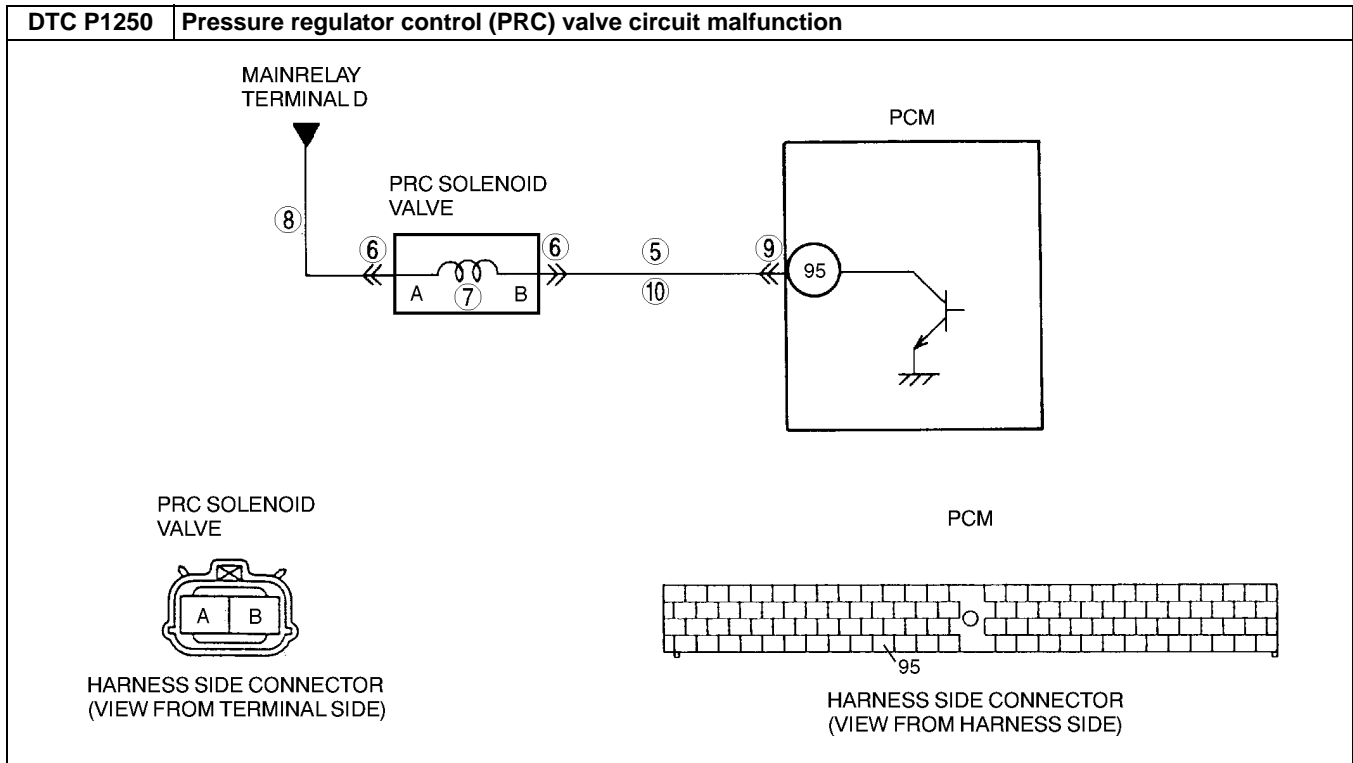

### Diagnostic procedure

STEP	INSPECTION		ACTION
1	<b>VERIFY FREEZE FRAME DATA HAS BEEN RECORDED</b> <ul style="list-style-type: none"> <li>• Has FREEZE FRAME DATA been recorded?</li> </ul>	Yes	Go to next step.
		No	Record FREEZE FRAME DATA on repair order, then go to next step.
2	<b>VERIFY RELATED REPAIR INFORMATION AVAILABILITY</b> <ul style="list-style-type: none"> <li>• Check for related Service Bulletins and/or on-line repair information availability.</li> <li>• Is any related repair information available?</li> </ul>	Yes	Perform repair or diagnosis according to available repair information. <ul style="list-style-type: none"> <li>• If vehicle is not repaired, go to next step.</li> </ul>
		No	Go to next step.
3	<b>CLASSIFY INTERMITTENT CONCERN OR CONTINUOUS CONCERN</b> <ul style="list-style-type: none"> <li>• Clear DTC from memory using WDS or equivalent.</li> <li>• Turn ignition key to OFF then Start engine.</li> <li>• Is PENDING CODE of same DTC present?</li> </ul>	Yes	Go to next step.
		No	Refer to intermittent concern. (See 01-03A-4 INTERMITTENT CONCERN TROUBLESHOOTING [ZM].)
4	<b>CLASSIFY OPEN CIRCUIT OR SHORT TO GROUND MALFUNCTION</b> <ul style="list-style-type: none"> <li>• Disconnect PRC solenoid valve tube that connects to intake manifold.</li> <li>• Connect vacuum pump to PRC solenoid valve.</li> <li>• Apply vacuum and wait <b>5 seconds</b>.</li> <li>• Is vacuum maintained?</li> </ul>	Yes	Go to Step 6.
		No	Go to next step.
5	<b>INSPECT PASSAGE CONTROL OF PRC SOLENOID VALVE</b> <ul style="list-style-type: none"> <li>• Turn ignition key to OFF.</li> <li>• Disconnect PRC solenoid valve connector.</li> <li>• Is vacuum maintained?</li> </ul>	Yes	Repair or replace harness between PCM terminal 95 and PRC solenoid valve terminal B for short to ground, then go to Step 11.
		No	Replace PRC solenoid valve, then go to Step 11.
6	<b>INSPECT POOR CONNECTION OF PRC SOLENOID VALVE CONNECTOR</b> <ul style="list-style-type: none"> <li>• Turn ignition key to OFF.</li> <li>• Check for poor connection (damaged/pulled-out pins, corrosion, etc.).</li> <li>• Is there malfunction?</li> </ul>	Yes	Repair or replace terminal, then go to Step 11.
		No	Go to next step.
7	<b>INSPECT PRC SOLENOID VALVE</b> <ul style="list-style-type: none"> <li>• Measure resistance between PRC solenoid valve terminals (part-side).</li> <li>• Is resistance <b>within 22—26 ohms</b>?</li> </ul>	Yes	Go to next step.
		No	Replace PRC solenoid valve, then go to Step 11.

## ON-BOARD DIAGNOSTIC [ENGINE CONTROL SYSTEM (ZM)]

STEP	INSPECTION	ACTION	
8	<b>INSPECT PRC SOLENOID VALVE POWER SUPPLY CIRCUIT FOR OPEN CIRCUIT</b> <ul style="list-style-type: none"> <li>• Turn ignition key to ON (Engine OFF).</li> <li>• Measure voltage between PRC solenoid valve terminal A (harness-side) and body ground.</li> <li>• Is voltage <b>B+</b>?</li> </ul>	Yes	Go to next step.
		No	Repair or replace harness for open, then go to Step 11.
9	<b>INSPECT PCM CONNECTOR FOR POOR CONNECTION</b> <ul style="list-style-type: none"> <li>• Turn ignition key to OFF.</li> <li>• Disconnect PCM connector.</li> <li>• Check for poor connection at terminal 95 (damaged/pulled-out pins, corrosion, etc.).</li> <li>• Is there malfunction?</li> </ul>	Yes	Repair terminal, then go to Step 11.
		No	Go to next step.
10	<b>INSPECT PRC SOLENOID VALVE CONTROL CIRCUIT</b> <ul style="list-style-type: none"> <li>• Connect breakout box with PCM disconnected.</li> <li>• Turn ignition key to ON (Engine OFF).</li> <li>• Measure voltage between PRC solenoid valve terminal B (harness-side) and body ground.</li> <li>• Is voltage <b>B+</b>?</li> </ul>	Yes	Repair or replace harness for short to power, then go to next step.
		No	Check for continuity between PRC solenoid valve terminal B (harness-side) and breakout box terminal 95. <ul style="list-style-type: none"> <li>• If there is continuity, go to next step.</li> <li>• If there is no continuity, repair or replace harness for open, then go to next step.</li> </ul>
11	<b>VERIFY TROUBLESHOOTING OF DTC P1250 COMPLETED</b> <ul style="list-style-type: none"> <li>• Make sure to reconnect all disconnected connectors.</li> <li>• Clear DTC from memory using WDS or equivalent.</li> <li>• Turn ignition key to OFF then start engine.</li> <li>• Is PENDING CODE of same DTC present?</li> </ul>	Yes	Replace PCM, then go to next step.
		No	Go to next step.
12	<b>VERIFY AFTER REPAIR PROCEDURE</b> <ul style="list-style-type: none"> <li>• Perform "After Repair Procedure". (See 01-02A-10 AFTER REPAIR PROCEDURE [ZM].)</li> <li>• Is there any DTC present?</li> </ul>	Yes	Go to applicable DTC inspection. (See 01-02A-15 DTC TABLE [ZM].)
		No	Troubleshooting completed.

### DTC P1345 [ZM]

A3U010201083W23

DTC P1345	Camshaft position (CMP) sensor circuit malfunction
<b>DETECTION CONDITION</b>	<ul style="list-style-type: none"> <li>• PCM monitor input voltage from CMP sensor. If PCM does not receive pulse signal the proper pulse signal from CMP sensor while crankshaft 12 rotations, PCM determines that CMP circuit has malfunction.</li> </ul> <b>Diagnostic support note</b> <ul style="list-style-type: none"> <li>• This is a continuous monitor (CCM)</li> <li>• MIL illuminates if PCM detects the above malfunction condition during first drive cycle.</li> <li>• PENDING CODE is not available.</li> <li>• FREEZE FRAME DATA is available.</li> <li>• DTC is stored in PCM memory.</li> </ul>
<b>POSSIBLE CAUSE</b>	<ul style="list-style-type: none"> <li>• CMP sensor malfunction</li> <li>• Connector or terminal malfunction</li> <li>• Open circuit between main relay terminal D and CMP sensor terminal A</li> <li>• Open circuit between CMP sensor terminal B and PCM terminal 85</li> <li>• Open circuit between CMP sensor terminal C and body ground</li> <li>• Short to ground circuit between main relay terminal D and CMP sensor terminal A</li> <li>• Short to ground circuit between CMP sensor terminal B and PCM terminal 85</li> </ul>

# ON-BOARD DIAGNOSTIC [ENGINE CONTROL SYSTEM (ZM)]

01-02A

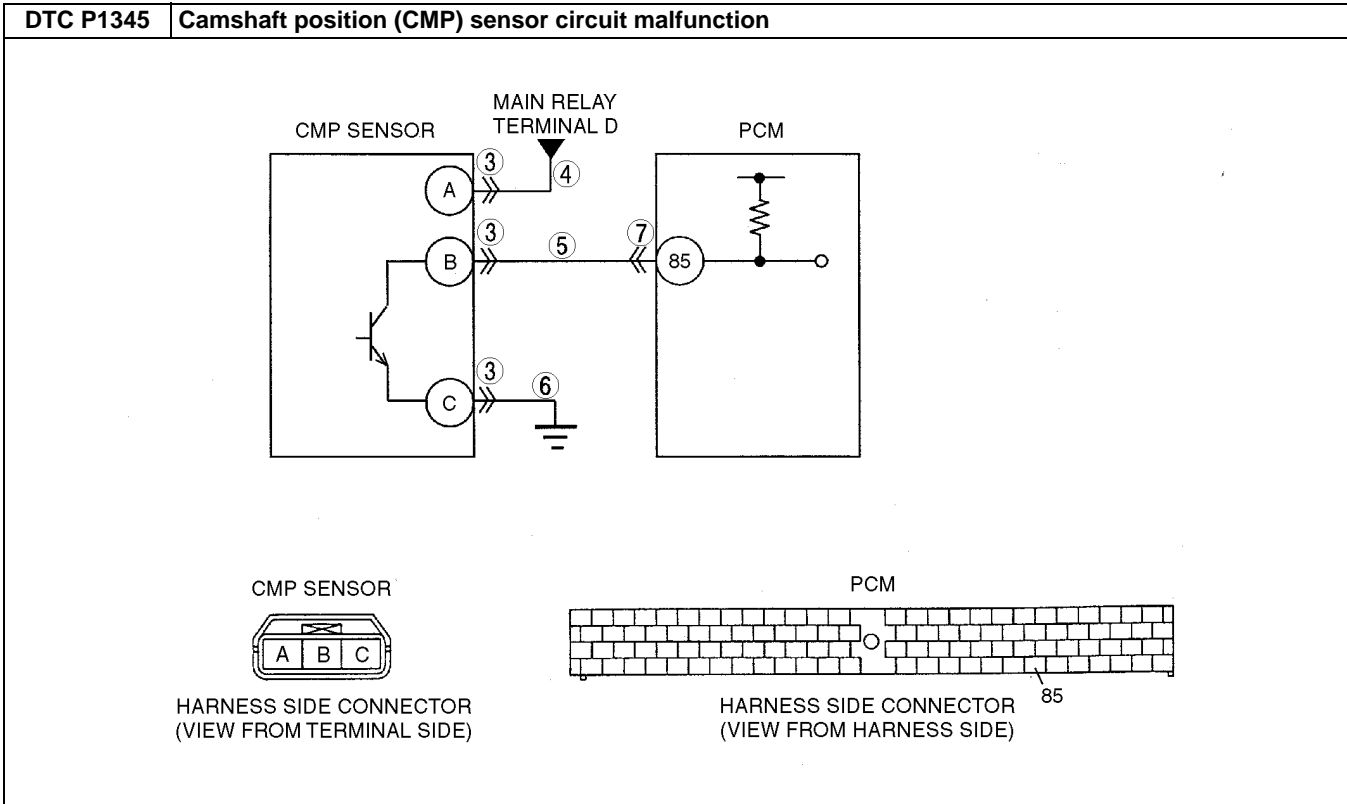

### Diagnostic procedure

STEP	INSPECTION		ACTION
1	<b>VERIFY RELATED REPAIR INFORMATION AVAILABILITY</b> <ul style="list-style-type: none"> <li>Check for related Service Information availability.</li> <li>Is any related Service Information available?</li> </ul>	Yes	Perform repair or diagnosis according to available Service Information <ul style="list-style-type: none"> <li>If vehicle is not repaired, go to next step.</li> </ul>
		No	Go to next step.
2	<b>CLASSIFY INTERMITTENT CONCERN OR CONTINUOUS CONCERN</b> <ul style="list-style-type: none"> <li>Turn ignition key to ON (engine OFF).</li> <li>Clear DTC from PCM memory using WDS or equivalent.</li> <li>Start engine.</li> <li>Is same DTC present?</li> </ul>	Yes	Go to next step.
		No	Intermittent concern exists. Go to INTERMITTENT CONCERN TROUBLESHOOTING procedure. (See 01-03A-4 INTERMITTENT CONCERN TROUBLESHOOTING [ZM].)
3	<b>INSPECT CMP SENSOR CONNECTOR FOR POOR CONNECTION</b> <ul style="list-style-type: none"> <li>Turn ignition key to OFF.</li> <li>Disconnect CMP sensor connector.</li> <li>Check for poor connection (damaged/pulled-out terminals, corrosion, etc.).</li> <li>Is there malfunction?</li> </ul>	Yes	Repair or replace terminal, then go to Step 8.
		No	Go to next step.
4	<b>INSPECT CMP SENSOR POWER CIRCUIT</b> <ul style="list-style-type: none"> <li>Turn ignition key to ON (Engine OFF).</li> <li>Measure voltage between CMP sensor terminal A (harness-side) and body ground.</li> <li>Is voltage <b>B+</b>?</li> </ul>	Yes	Go to next step.
		No	Repair or replace for open or short to ground, then go to Step 8.
5	<b>INSPECT CMP SENSOR SIGNAL CIRCUIT</b> <ul style="list-style-type: none"> <li>Measure voltage between CMP sensor terminal B (harness-side) and body ground.</li> <li>Is voltage <b>B+</b>?</li> </ul>	Yes	Go to next step
		No	Repair or replace for open, then go to Step 8.
6	<b>INSPECT CMP SENSOR GROUND CIRCUIT</b> <ul style="list-style-type: none"> <li>Turn ignition key to OFF.</li> <li>Check continuity between CMP sensor terminal C (harness-side) and body ground.</li> <li>Is there continuity?</li> </ul>	Yes	Go to next step.
		No	Repair or replace for open, then go to Step 8.

# ON-BOARD DIAGNOSTIC [ENGINE CONTROL SYSTEM (ZM)]

STEP	INSPECTION		ACTION
7	<b>INSPECT CMP SENSOR</b> <ul style="list-style-type: none"> <li>Check pulsation signal coming out from PCM terminal 85 (harness-side) using voltmeter while cranking engine.</li> <li>Is there signal?</li> </ul>	Yes	Go to next step.
		No	Replace CMP sensor, then go to next step.
8	<b>VERIFY TROUBLESHOOTING OF DTC P1345 COMPLETED</b> <ul style="list-style-type: none"> <li>Make sure to reconnect all disconnected connectors.</li> <li>Turn ignition key to ON (engine OFF).</li> <li>Clear DTC from PCM memory using WDS or equivalent.</li> <li>Start engine.</li> <li>Is same DTC present?</li> </ul>	Yes	Replace PCM, then go to next step.
		No	Go to next step.
9	<b>VERIFY AFTER REPAIR PROCEDURE</b> <ul style="list-style-type: none"> <li>Perform "After Repair Procedure". (See 01-02A-10 AFTER REPAIR PROCEDURE [ZM].)</li> <li>Is there any DTC present?</li> </ul>	Yes	Go to applicable DTC inspection. (See 01-02A-15 DTC TABLE [ZM].)
		No	Troubleshooting completed.

## DTC P1449 [ZM]

A3U010201083W24

DTC P1449	Canister drain cut valve (CDCV) circuit malfunction
<b>DETECTION CONDITION</b>	<ul style="list-style-type: none"> <li>PCM monitors the input voltages from CDCV just after turning the ignition key to ON. If voltage at PCM terminal 18 remains low or high, PCM determines that CDCV circuit has malfunction.</li> </ul> <p><b>Diagnostic support note</b></p> <ul style="list-style-type: none"> <li>This is a diagnostic support DTC (monitored one per key cycle).</li> <li>MIL does not illuminate.</li> <li>FREEZE FRAME DATA is not available.</li> <li>DTC is not stored in PCM memory.</li> </ul>
<b>POSSIBLE CAUSE</b>	<ul style="list-style-type: none"> <li>CDCV malfunction</li> <li>Connector or terminal malfunction</li> <li>Short to ground in wiring between CDCV terminal B and PCM terminal 18</li> <li>Open circuit in wiring between main relay terminal D and CDCV terminal A</li> <li>Open circuit in wiring between CDCV terminal B and PCM terminal 18</li> <li>Short to power circuit between CDCV terminal B and PCM terminal 18</li> <li>PCM malfunction</li> </ul>

## ON-BOARD DIAGNOSTIC [ENGINE CONTROL SYSTEM (ZM)]

### Diagnostic procedure

STEP	INSPECTION	ACTION	
1	<b>VERIFY RELATED REPAIR INFORMATION AVAILABILITY</b> <ul style="list-style-type: none"> <li>• Check for related Service Bulletins availability.</li> <li>• Is any related repair information available?</li> </ul>	Yes	Perform repair or diagnosis according to available repair information. <ul style="list-style-type: none"> <li>• If vehicle is not repaired, go to next step.</li> </ul>
		No	Go to next step.
2	<b>CLASSIFY INTERMITTENT CONCERN OR CONTINUOUS CONCERN</b> <ul style="list-style-type: none"> <li>• Turn ignition key to OFF then ON (Engine OFF).</li> <li>• Is same DTC present?</li> </ul>	Yes	Go to next step.
		No	Refer to intermittent concern. (See 01-03A-4 INTERMITTENT CONCERN TROUBLESHOOTING [ZM].)
3	<b>INSPECT CDCV CONNECTOR FOR POOR CONNECTION</b> <ul style="list-style-type: none"> <li>• Turn ignition key to OFF.</li> <li>• Check for poor connection (damaged/pulled-out pins, corrosion, etc.).</li> <li>• Is there malfunction?</li> </ul>	Yes	Repair or replace terminal, then go to Step 9.
		No	Go to next step.
4	<b>INSPECT CDCV</b> <ul style="list-style-type: none"> <li>• Measure resistance between CDCV terminals (part-side).</li> <li>• Is resistance <b>within 17—21 ohms</b>?</li> </ul>	Yes	Go to next step.
		No	Replace CDCV, then go to Step 9.
5	<b>INSPECT CDCV POWER SUPPLY CIRCUIT FOR OPEN CIRCUIT</b> <ul style="list-style-type: none"> <li>• Turn ignition key to ON (Engine OFF).</li> <li>• Measure voltage between CDCV terminal A (harness-side) and body ground.</li> <li>• Is voltage <b>B+</b>?</li> </ul>	Yes	Go to next step.
		No	Repair or replace harness for open, then go to Step 9.
6	<b>INSPECT PCM CONNECTOR FOR POOR CONNECTION</b> <ul style="list-style-type: none"> <li>• Turn ignition key to OFF.</li> <li>• Disconnect PCM connector.</li> <li>• Check for poor connection at terminal 18. (damaged/pulled-out pins, corrosion, etc.).</li> <li>• Is there malfunction?</li> </ul>	Yes	Repair terminal, then go to Step 9.
		No	Go to next step.
7	<b>INSPECT CDCV CONTROL CIRCUIT FOR SHORT TO GROUND</b> <ul style="list-style-type: none"> <li>• Disconnect PCM connector.</li> <li>• Check for continuity between CDCV terminal B (harness-side) and body ground.</li> <li>• Is there continuity?</li> </ul>	Yes	Repair or replace harness for short to ground, then go to Step 9.
		No	Go to next step.
8	<b>INSPECT CDCV CONTROL CIRCUIT FOR SHORT TO POWER</b> <ul style="list-style-type: none"> <li>• Connect breakout box with PCM disconnected.</li> <li>• Turn ignition key to ON (Engine OFF).</li> <li>• Measure voltage between CDCV terminal B (harness-side) and body ground.</li> <li>• Is the voltage <b>B+</b>?</li> </ul>	Yes	Repair or replace harness for short to power, then go to next step.
		No	Check for continuity between CDCV terminal B (harness-side) and breakout box terminal 18. <ul style="list-style-type: none"> <li>• If there is continuity, go to next step.</li> <li>• If there is no continuity, repair or replace harness for open, then go to next step.</li> </ul>
9	<b>VERIFY TROUBLESHOOTING OF DTC P1449 COMPLETED</b> <ul style="list-style-type: none"> <li>• Make sure to reconnect all disconnected connectors.</li> <li>• Turn ignition key to OFF then ON (Engine OFF).</li> <li>• Is same DTC present?</li> </ul>	Yes	Replace PCM, then go to next step.
		No	Go to next step.
10	<b>VERIFY AFTER REPAIR PROCEDURE</b> <ul style="list-style-type: none"> <li>• Perform "After Repair Procedure". (See 01-02A-10 AFTER REPAIR PROCEDURE [ZM].)</li> <li>• Is there any DTC present?</li> </ul>	Yes	Go to applicable DTC inspection. (See 01-02A-15 DTC TABLE [ZM].)
		No	Troubleshooting completed.

01-02A

# ON-BOARD DIAGNOSTIC [ENGINE CONTROL SYSTEM (ZM)]

## DTC P1450 [ZM]

A3U010201083W25

<b>DTC P1450</b>	<b>Evaporative emission control system malfunction (excessive vacuum)</b>
<b>DETECTION CONDITION</b>	<ul style="list-style-type: none"> <li>• PCM monitors fuel tank pressure signal when monitoring conditions are met. If vacuum is <b>above <math>-3.92</math> kPa <math>\{-29.4</math> mmHg, <math>-1.16</math> inHg}</b> for <b>10 seconds</b>, PCM determines the excessive vacuum.</li> </ul> <p><b>MONITORING CONDITIONS</b></p> <ul style="list-style-type: none"> <li>— Intake air temperature is <b>above <math>-10</math> °C <math>\{14</math> °F}</b>.</li> <li>— Engine coolant temperature is <b>100 °C <math>\{212</math> °F} or below</b>.</li> <li>— Vehicle speed is <b>99.8 km/h <math>\{61.9</math> mph} or below</b>.</li> <li>— Engine coolant temperature at engine start is <b>below 35 °C <math>\{95</math> °F}</b>.</li> </ul> <p><b>Diagnostic support note</b></p> <ul style="list-style-type: none"> <li>• This is a continuous monitor (CCM).</li> <li>• MIL illuminates if PCM detects the above malfunction condition in two consecutive drive cycles.</li> <li>• PENDING CODE is available if PCM detects the above malfunction condition during first drive cycle.</li> <li>• FREEZE FRAME DATA is available.</li> <li>• DTC is stored in PCM memory.</li> </ul>
<b>POSSIBLE CAUSE</b>	<ul style="list-style-type: none"> <li>• CDCV malfunction</li> <li>• Air filter clogged</li> <li>• Charcoal canister malfunction</li> <li>• Evaporative drain passage clogged (including check valve)</li> <li>• Fuel tank pressure sensor malfunction</li> <li>• Purge solenoid valve malfunction</li> </ul>

### Diagnostic procedure

STEP	INSPECTION		ACTION
1	<b>VERIFY FREEZE FRAME DATA HAS BEEN RECORDED</b> <ul style="list-style-type: none"> <li>• Has FREEZE FRAME DATA been recorded?</li> </ul>	Yes	Go to next step.
		No	Record FREEZE FRAME DATA on repair order, then go to next step.
2	<b>VERIFY RELATED REPAIR INFORMATION AVAILABILITY</b> <ul style="list-style-type: none"> <li>• Check for related Service Bulletins availability.</li> <li>• Is any related repair information available?</li> </ul>	Yes	Perform repair or diagnosis according to available repair information. <ul style="list-style-type: none"> <li>• If vehicle is not repaired, go to next step.</li> </ul>
		No	Go to next step.
3	<b>VERIFY RELATED STORED DTCS</b> <ul style="list-style-type: none"> <li>• Turn ignition key to OFF then start engine.</li> <li>• Verify stored DTC.</li> <li>• Are DTCs P0443 and/or P1449 present?</li> </ul>	Yes	Go to appropriate DTC inspection.
		No	Go to next step.
4	<b>INSPECT CDCV FOR OPERATION SOUND</b> <ul style="list-style-type: none"> <li>• Perform CDCV inspection. (See 01-16-10 CANISTER DRAIN CUT VALVE (CDCV) INSPECTION.)</li> <li>• Is CDCV okay?</li> </ul>	Yes	Go to next step.
		No	Replace it if necessary, then go to Step 9.
5	<b>INSPECT PURGE SOLENOID VALVE</b> <ul style="list-style-type: none"> <li>• Disconnect vacuum hose that connects to intake manifold from purge solenoid valve.</li> <li>• Connect vacuum pump to purge solenoid valve.</li> <li>• Pump vacuum several times and wait a <b>few seconds</b>.</li> <li>• Does vacuum hold?</li> </ul>	Yes	Disconnect vacuum pump and connect vacuum hose to purge solenoid valve. Go to next step.
		No	Inspect purge solenoid valve and related harness. Replace it if necessary, then go to Step 9.
6	<b>INSPECT CHARCOAL CANISTER FOR CLOGGING</b> <ul style="list-style-type: none"> <li>• Remove charcoal canister and inspect for clogging. (See 01-16-9 CHARCOAL CANISTER INSPECTION.)</li> <li>• Is it okay?</li> </ul>	Yes	Go to next step.
		No	Replace charcoal canister, then go to Step 9.
7	<b>INSPECT FUEL TANK PRESSURE SENSOR</b> <ul style="list-style-type: none"> <li>• Inspect fuel tank pressure sensor. (See 01-40A-40 FUEL TANK PRESSURE SENSOR INSPECTION [ZM].)</li> <li>• Is it okay?</li> </ul>	Yes	Go to next step.
		No	Replace fuel tank pressure sensor, then go to Step 9.
8	<b>INSPECT AIR FILTER FOR CLOGGING</b> <ul style="list-style-type: none"> <li>• Remove and inspect air filter connected to CDCV for clogging.</li> <li>• Is it okay?</li> </ul>	Yes	Inspect for clogging in following area: <ul style="list-style-type: none"> <li>• From charcoal canister to CDCV</li> <li>• Drain passage including check valve                             <ul style="list-style-type: none"> <li>— Repair or replace faulty area, then go to next step.</li> </ul> </li> </ul>
		No	Repair or replace air filter, then go to next step.

## ON-BOARD DIAGNOSTIC [ENGINE CONTROL SYSTEM (ZM)]

STEP	INSPECTION	ACTION	
9	<b>VERIFY MONITORING CONDITION FOR EVAPORATIVE SYSTEM TEST</b> <ul style="list-style-type: none"> <li>• Make sure to reconnect all disconnected connectors.</li> <li>• Turn ignition key to ON (Engine OFF).</li> <li>• Clear DTC from memory using WDS or equivalent.</li> <li>• Verify that following conditions are met.                             <ul style="list-style-type: none"> <li>— BARO: <b>72.2 kPa {542 mmHg, 21.3 inHg} or higher</b></li> <li>— ECT: <b>-10.0—22.0 °C {14.0—72.0 °F}</b> [at barometric pressure <b>72.2 kPa {542 mmHg, 21.3 inHg}</b>]</li> <li>— IAT: <b>-10—60 °C {50—140 °F}</b></li> <li>— Fuel tank level: <b>15—85%</b></li> </ul> </li> <li>• Is there any condition out of specification?</li> </ul>	Yes	Take corrective action (e.g. cool down engine), then repeat this step.  <b>Note</b> <ul style="list-style-type: none"> <li>• Readings need to be in the indicated ranges to perform Drive Mode 4.</li> </ul>
		No	Go to next step.
10	<b>MONITOR EVAP SYSTEM BY DRIVE MODE 4</b> <ul style="list-style-type: none"> <li>• Run Drive Mode 4. (See 01-02A-13 Mode 4 (EVAP system repair verification drive mode).)</li> <li>• Stop vehicle and access ON BOARD SYSTEM READINESS TESTS menu of GENERIC OBD-II FUNCTIONS to inspect Drive Mode completion status.</li> <li>• Has EVAPORATIVE PURGE SYSTEM been monitored?</li> </ul>	Yes	Go to next step.
		No	Go back to Step 9.
11	<b>VERIFY TROUBLESHOOTING OF DTC P1450 COMPLETED</b> <ul style="list-style-type: none"> <li>• Is pending code of same DTC present?</li> </ul>	Yes	Replace PCM, then go to next step.
		No	Go to next step.
12	<b>VERIFY AFTER REPAIR PROCEDURE</b> <ul style="list-style-type: none"> <li>• Perform "After Repair Procedure". (See 01-02A-10 AFTER REPAIR PROCEDURE [ZM].)</li> <li>• Is there any DTC present?</li> </ul>	Yes	Go to applicable DTC inspection. (See 01-02A-15 DTC TABLE [ZM].)
		No	Troubleshooting completed.

01-02A

### DTC P1487 [ZM]

A3U010201083W26

DTC P1487	EGR boost sensor solenoid valve circuit malfunction
<b>DETECTION CONDITION</b>	<ul style="list-style-type: none"> <li>• PCM monitors input voltages from EGR boost sensor solenoid valve just after turning the ignition key to ON. If voltage at PCM terminal 98 remains low or high, PCM determines that EGR boost sensor solenoid valve circuit has malfunction.</li> </ul> <p><b>Diagnostic support note</b></p> <ul style="list-style-type: none"> <li>• This is a diagnostic support DTC (monitored once per key cycle).</li> <li>• MIL does not illuminate.</li> <li>• FREEZE FRAME DATA is not available.</li> <li>• DTC is not stored in PCM memory.</li> </ul>
<b>POSSIBLE CAUSE</b>	<ul style="list-style-type: none"> <li>• EGR boost sensor solenoid valve malfunction</li> <li>• Connector or terminal malfunction</li> <li>• Short to ground in wiring between EGR boost sensor solenoid valve terminal B and PCM terminal 98</li> <li>• Open circuit in wiring between main relay terminal D and EGR boost sensor solenoid valve terminal A</li> <li>• Open circuit in wiring between EGR boost sensor solenoid valve terminal B and PCM terminal 98</li> <li>• Short to power circuit between EGR boost sensor solenoid valve terminal B and PCM terminal 98</li> <li>• PCM malfunction</li> </ul>

# ON-BOARD DIAGNOSTIC [ENGINE CONTROL SYSTEM (ZM)]

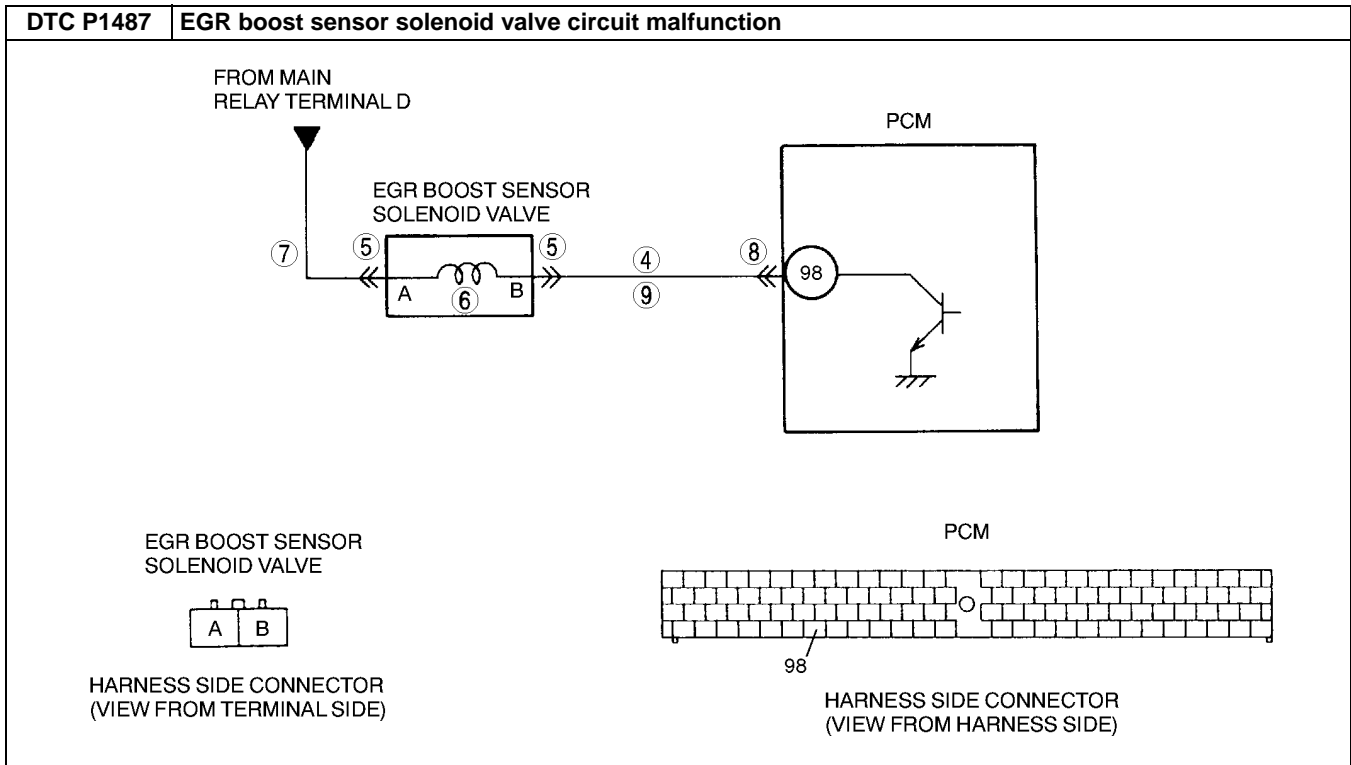

### Diagnostic procedure

STEP	INSPECTION		ACTION
1	<b>VERIFY RELATED REPAIR INFORMATION AVAILABILITY</b> <ul style="list-style-type: none"> <li>• Check for related Service Bulletins availability.</li> <li>• Is any related repair information available?</li> </ul>	Yes	Perform repair or diagnosis according to available repair information. <ul style="list-style-type: none"> <li>• If vehicle is not repaired, go to next step.</li> </ul>
		No	Go to next step.
2	<b>CLASSIFY INTERMITTENT CONCERN OR CONTINUOUS CONCERN</b> <ul style="list-style-type: none"> <li>• Turn ignition key to OFF then ON (Engine OFF).</li> <li>• Is same DTC present?</li> </ul>	Yes	Go to next step.
		No	Intermittent concern exists. Go to INTERMITTENT CONCERN TROUBLESHOOTING procedure. (See 01-03A-4 INTERMITTENT CONCERN TROUBLESHOOTING [ZM].)
3	<b>CLASSIFY OPEN CIRCUIT OR SHORT TO GROUND MALFUNCTION</b> <ul style="list-style-type: none"> <li>• Disconnect EGR boost sensor solenoid valve tube at solenoid side that connects to EGR valve.</li> <li>• Connect vacuum pump to EGR boost solenoid valve.</li> <li>• Apply vacuum.</li> <li>• Wait for 5 seconds.</li> <li>• Is vacuum maintained?</li> </ul>	Yes	Go to Step 5.
		No	Go to next step.
4	<b>INSPECT PASSAGE CONTROL OF EGR BOOST SENSOR SOLENOID VALVE</b> <ul style="list-style-type: none"> <li>• Turn ignition key to OFF.</li> <li>• Disconnect EGR boost sensor solenoid valve connector.</li> <li>• Apply vacuum and wait for 5 seconds.</li> <li>• Is vacuum maintained?</li> </ul>	Yes	Repair or replace harness between solenoid valve terminal B and PCM terminal 98 for short to ground, then go to Step 10.
		No	Replace EGR boost sensor solenoid valve, then go to Step 10.
5	<b>INSPECT EGR BOOST SENSOR SOLENOID VALVE CONNECTOR FOR POOR CONNECTION</b> <ul style="list-style-type: none"> <li>• Turn ignition key to OFF.</li> <li>• Check for poor connection (damaged/pulled-out pins, corrosion, etc.).</li> <li>• Is there malfunction?</li> </ul>	Yes	Repair or replace terminal, then go to Step 10.
		No	Go to next step.



## ON-BOARD DIAGNOSTIC [ENGINE CONTROL SYSTEM (ZM)]

STEP	INSPECTION	ACTION	
6	<b>INSPECT EGR BOOST SENSOR SOLENOID VALVE</b> <ul style="list-style-type: none"> <li>Measure resistance between EGR boost sensor solenoid valve terminals (part-side).</li> <li>Is resistance <b>within 22—26 ohms</b>?</li> </ul>	Yes	Go to next step.
		No	Replace EGR boost sensor solenoid valve, then go to Step 10.
7	<b>INSPECT EGR BOOST SENSOR SOLENOID VALVE POWER SUPPLY CIRCUIT FOR OPEN CIRCUIT</b> <ul style="list-style-type: none"> <li>Turn ignition key to ON (Engine OFF).</li> <li>Measure voltage between EGR boost sensor solenoid valve terminal A (harness-side) and body ground.</li> <li>Is voltage <b>B+</b>?</li> </ul>	Yes	Go to next step.
		No	Repair or replace harness for open, then go to Step 10.
8	<b>INSPECT PCM CONNECTOR FOR POOR CONNECTION</b> <ul style="list-style-type: none"> <li>Turn ignition key to OFF.</li> <li>Disconnect PCM connector.</li> <li>Check for poor connection at terminal 98. (damaged/pulled-out pins, corrosion, etc.).</li> <li>Is there malfunction?</li> </ul>	Yes	Repair terminal, then go to Step 10.
		No	Go to next step.
9	<b>INSPECT EGR BOOST SENSOR SOLENOID VALVE CONTROL CIRCUIT</b> <ul style="list-style-type: none"> <li>Connect breakout box with PCM disconnected.</li> <li>Turn ignition key to ON (Engine OFF).</li> <li>Measure voltage between breakout box terminal B (harness-side) and body ground.</li> <li>Is voltage <b>B+</b>?</li> </ul>	Yes	Repair or replace harness for short to power, then go to next step.
		No	Check for continuity between EGR boost sensor solenoid valve terminal B (harness-side) and breakout box terminal 98. <ul style="list-style-type: none"> <li>If there is continuity, go to next step.</li> <li>If there is no continuity, repair or replace harness for open, then go to next step.</li> </ul>
10	<b>VERIFY TROUBLESHOOTING OF DTC P1487 COMPLETED</b> <ul style="list-style-type: none"> <li>Make sure to reconnect all disconnected connectors.</li> <li>Turn ignition key to OFF then ON (Engine OFF).</li> <li>Is same DTC present?</li> </ul>	Yes	Replace PCM, then go to next step.
		No	Go to next step.
11	<b>VERIFY AFTER REPAIR PROCEDURE</b> <ul style="list-style-type: none"> <li>Perform "After Repair Procedure". (See 01-02A-10 AFTER REPAIR PROCEDURE [ZM].)</li> <li>Is there any DTC present?</li> </ul>	Yes	Go to applicable DTC inspection. (See 01-02A-15 DTC TABLE [ZM].)
		No	Troubleshooting completed.

01-02A

### DTC P1496 [ZM]

A3U010201083W27

DTC P1496	EGR valve stepping motor coil 1 open or short circuit
<b>DETECTION CONDITION</b>	<ul style="list-style-type: none"> <li>PCM monitors input voltages from EGR valve coil control circuit just after turning ignition key to ON. If voltage at PCM terminal 68 remains low or high, PCM determines that EGR valve circuit has malfunction.</li> </ul> <b>Diagnostic support note</b> <ul style="list-style-type: none"> <li>This is a diagnostic support DTC (monitored once per key cycle)</li> <li>MIL does not illuminate.</li> <li>FREEZE FRAME DATA is not available.</li> <li>DTC is not stored in PCM memory.</li> </ul>
<b>POSSIBLE CAUSE</b>	<ul style="list-style-type: none"> <li>EGR valve malfunction</li> <li>Connector or terminal malfunction</li> <li>Short to ground circuit in wiring between EGR valve terminal E and PCM terminal 68</li> <li>Open circuit in wiring between EGR valve terminal E and PCM terminal 68</li> <li>Short to power circuit in wiring between EGR valve terminal E and PCM terminal 68</li> <li>Open circuit in wiring between main relay terminal D and EGR valve terminal C</li> <li>PCM malfunction</li> </ul>

# ON-BOARD DIAGNOSTIC [ENGINE CONTROL SYSTEM (ZM)]

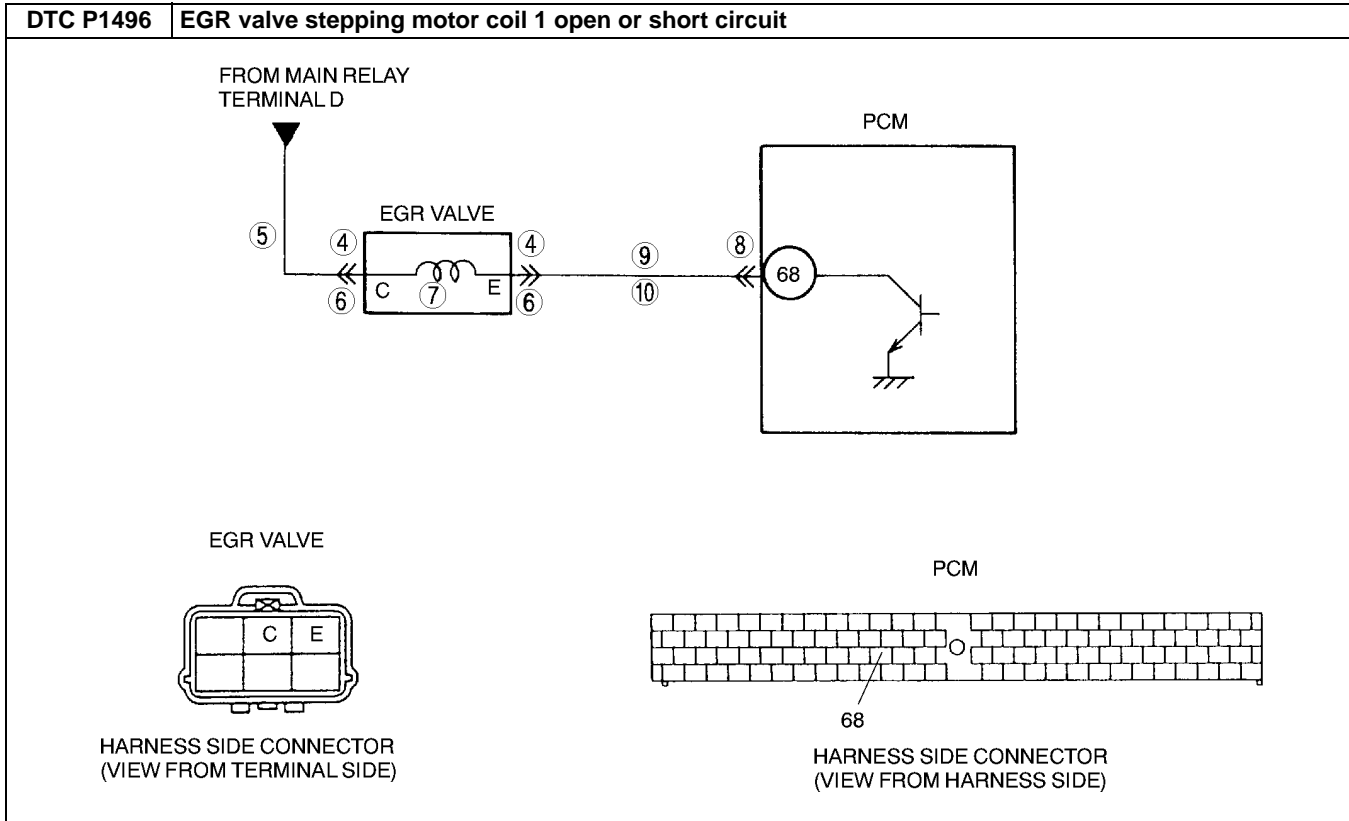

### Diagnostic procedure

STEP	INSPECTION		ACTION
1	<b>VERIFY RELATED REPAIR INFORMATION AVAILABILITY</b> <ul style="list-style-type: none"> <li>• Check for related Service Bulletins availability.</li> <li>• Is any repair information available?</li> </ul>	Yes	Perform repair or diagnosis according to available repair information. <ul style="list-style-type: none"> <li>• If vehicle is not repaired, go to next step.</li> </ul>
		No	Go to next step.
2	<b>CLASSIFY INTERMITTENT CONCERN OR CONTINUOUS CONCERN</b> <ul style="list-style-type: none"> <li>• Turn ignition key to OFF then ON (Engine OFF).</li> <li>• Is same DTC present?</li> </ul>	Yes	Go to next step.
		No	Refer to intermittent concern. (See 01-03A-4 INTERMITTENT CONCERN TROUBLESHOOTING [ZM].)
3	<b>CLASSIFY POWER CIRCUIT OR CONTROL CIRCUIT MALFUNCTION</b> <ul style="list-style-type: none"> <li>• Is same DTC and P1497 present?</li> </ul>	Yes	Malfunction at EGR valve or power circuit. Go to next step.
		No	Malfunction at EGR valve or control circuit. Go to Step 6.
4	<b>INSPECT EGR VALVE FOR POOR CONNECTION</b> <ul style="list-style-type: none"> <li>• Turn ignition key to OFF.</li> <li>• Disconnect EGR valve connector.</li> <li>• Check for poor connection (damaged/pulled-out terminals, corrosion, etc.).</li> <li>• Is there malfunction?</li> </ul>	Yes	Repair or replace terminals, then go to Step 11.
		No	Go to next step.
5	<b>INSPECT POWER CIRCUIT FOR OPEN CIRCUIT</b> <ul style="list-style-type: none"> <li>• Turn ignition key to ON (Engine OFF).</li> <li>• Measure voltage between EGR valve terminal C (harness-side) and body ground.</li> <li>• Is voltage B+?</li> </ul>	Yes	Inspect EGR valve coils 1 and 2. (See 01-16-15 EGR VALVE INSPECTION.) <ul style="list-style-type: none"> <li>• If there is a malfunction, replace EGR valve, and then go to Step 11.</li> <li>• If there is no malfunction, go to Step 11.</li> </ul>
		No	Repair or replace harness, then go to Step 11.
6	<b>INSPECT EGR VALVE FOR POOR CONNECTION</b> <ul style="list-style-type: none"> <li>• Turn ignition key to OFF.</li> <li>• Disconnect EGR valve connector.</li> <li>• Check for poor connection (damaged/pulled-out terminals, corrosion, etc.).</li> <li>• Is there malfunction?</li> </ul>	Yes	Repair or replace terminals, then go to Step 11.
		No	Go to next step.

## ON-BOARD DIAGNOSTIC [ENGINE CONTROL SYSTEM (ZM)]

STEP	INSPECTION	ACTION	
7	<b>INSPECT EGR VALVE</b> <ul style="list-style-type: none"> <li>• Measure resistance between EGR valve terminals C and E (part-side).</li> <li>• Is resistance <b>within 20—24 ohms</b>?</li> </ul>	Yes	Go to next step.
		No	Replace EGR valve, then go to Step 11.
8	<b>INSPECT PCM CONNECTOR FOR POOR CONNECTION</b> <ul style="list-style-type: none"> <li>• Disconnect PCM connector.</li> <li>• Check for poor connection at terminal 68 (damaged/pulled-out terminals, corrosion, etc.).</li> <li>• Is there malfunction?</li> </ul>	Yes	Repair terminal, then go to Step 11.
		No	Go to next step.
9	<b>INSPECT CONTROL CIRCUIT FOR SHORT</b> <ul style="list-style-type: none"> <li>• Check continuity between EGR valve terminal E (harness-side) and body ground.</li> <li>• Is there continuity?</li> </ul>	Yes	Repair or replace harness for short to ground, then go to Step 11.
		No	Measure voltage between EGR valve terminal E and body ground. <ul style="list-style-type: none"> <li>• If voltage is <b>B+</b>, repair or replace harness for short to power, then go to next step.</li> <li>• If voltage is <b>approx. 0 V</b>, go to next step.</li> </ul>
10	<b>INSPECT CONTROL CIRCUIT FOR OPEN CIRCUIT</b> <ul style="list-style-type: none"> <li>• Connect breakout box with PCM disconnected.</li> <li>• Check for continuity between EGR valve terminal E (harness-side) and breakout box terminal 68.</li> <li>• Is there continuity?</li> </ul>	Yes	Go to next step.
		No	Repair or replace harness for open, then go to next step.
11	<b>VERIFY TROUBLESHOOTING OF DTC P1496 COMPLETED</b> <ul style="list-style-type: none"> <li>• Make sure to reconnect all disconnected connectors.</li> <li>• Turn ignition key to OFF then ON (Engine OFF).</li> <li>• Is same DTC present?</li> </ul>	Yes	Replace PCM, then go to next step.
		No	Go to next step.
12	<b>VERIFY AFTER REPAIR PROCEDURE</b> <ul style="list-style-type: none"> <li>• Perform "After Repair Procedure". (See 01-02A-10 AFTER REPAIR PROCEDURE [ZM].)</li> <li>• Is there any DTC present?</li> </ul>	Yes	Go to applicable DTC inspection. (See 01-02A-15 DTC TABLE [ZM].)
		No	Troubleshooting completed.

01-02A

### DTC P1497 [ZM]

A3U010201083W28

DTC P1497	EGR valve stepping motor coil 2 open or short circuit
<b>DETECTION CONDITION</b>	<ul style="list-style-type: none"> <li>• PCM monitors input voltages from EGR valve coil control circuit just after turning ignition key to ON. If voltage at PCM terminal 72 remains low or high, PCM determines that EGR valve circuit has malfunction.</li> </ul> <p><b>Diagnostic support note</b></p> <ul style="list-style-type: none"> <li>• This is a diagnostic support DTC (monitored once per key cycle).</li> <li>• MIL does not illuminate.</li> <li>• FREEZE FRAME DATA is not available.</li> <li>• DTC is not stored in PCM memory.</li> </ul>
<b>POSSIBLE CAUSE</b>	<ul style="list-style-type: none"> <li>• EGR valve malfunction</li> <li>• Connector or terminal malfunction</li> <li>• Short to ground circuit in wiring between EGR valve terminal A and PCM terminal 72</li> <li>• Open circuit in wiring between EGR valve terminal A and PCM terminal 72</li> <li>• Short to power circuit in wiring between EGR valve terminal A and PCM terminal 72</li> <li>• Open circuit in wiring between main relay terminal D and EGR valve terminal C</li> <li>• PCM malfunction</li> </ul>

# ON-BOARD DIAGNOSTIC [ENGINE CONTROL SYSTEM (ZM)]

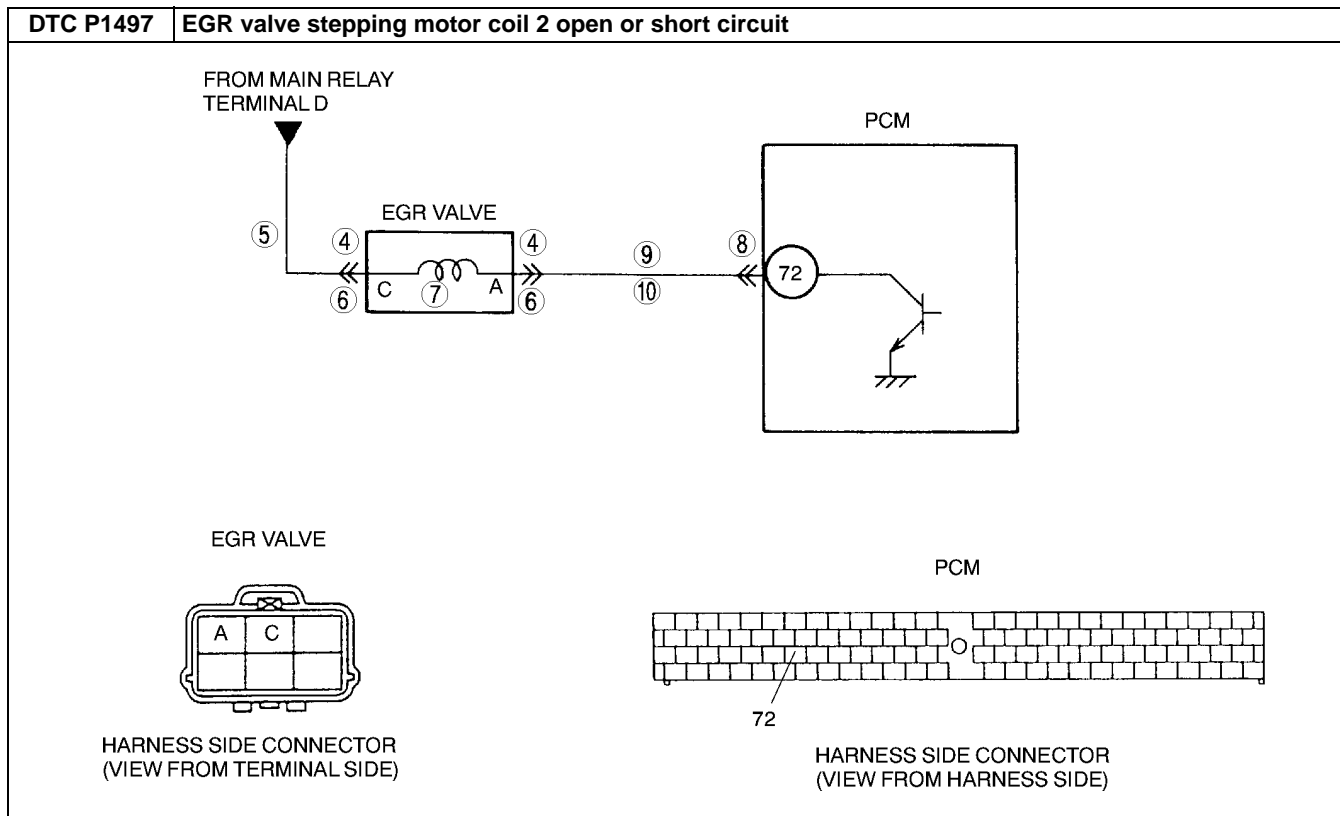

### Diagnostic procedure

STEP	INSPECTION		ACTION
1	<b>VERIFY RELATED REPAIR INFORMATION AVAILABILITY</b> <ul style="list-style-type: none"> <li>Check for related Service Bulletins availability.</li> <li>Is any repair information available?</li> </ul>	Yes	Perform repair or diagnosis according to available repair information. <ul style="list-style-type: none"> <li>If vehicle is not repaired, go to next step.</li> </ul>
		No	Go to next step.
2	<b>CLASSIFY INTERMITTENT CONCERN OR CONTINUOUS CONCERN</b> <ul style="list-style-type: none"> <li>Turn ignition key to OFF then ON (Engine OFF).</li> <li>Is same DTC present?</li> </ul>	Yes	Go to next step.
		No	Refer to intermittent concern. (See 01-03A-4 INTERMITTENT CONCERN TROUBLESHOOTING [ZM].)
3	<b>CLASSIFY POWER CIRCUIT OR CONTROL CIRCUIT MALFUNCTION</b> <ul style="list-style-type: none"> <li>Is same DTC and P1496 present?</li> </ul>	Yes	Malfunction at EGR valve or power circuit. Go to next step.
		No	Malfunction at EGR valve or control circuit. Go to Step 6.
4	<b>INSPECT EGR VALVE FOR POOR CONNECTION</b> <ul style="list-style-type: none"> <li>Turn ignition key to OFF.</li> <li>Disconnect EGR valve connector.</li> <li>Check for poor connection (damaged/pulled-out terminals, corrosion, etc.).</li> <li>Is there malfunction?</li> </ul>	Yes	Repair or replace terminals, then go to Step 11.
		No	Go to next step.
5	<b>INSPECT POWER CIRCUIT FOR OPEN CIRCUIT</b> <ul style="list-style-type: none"> <li>Turn ignition key to ON (Engine OFF).</li> <li>Measure voltage between EGR valve terminal C (harness-side) and body ground.</li> <li>Is voltage B+?</li> </ul>	Yes	Inspect EGR valve coils 1 and 2. (See 01-16-15 EGR VALVE INSPECTION.) <ul style="list-style-type: none"> <li>If there is a malfunction, replace EGR valve, and then go to Step 11.</li> <li>If there is no malfunction, then go to Step 11.</li> </ul>
		No	Repair or replace harness for open circuit, then go to Step 11.
6	<b>INSPECT EGR VALVE FOR POOR CONNECTION</b> <ul style="list-style-type: none"> <li>Turn ignition key to OFF.</li> <li>Disconnect EGR valve connector.</li> <li>Check for poor connection (damaged/pulled-out terminals, corrosion, etc.).</li> <li>Is there malfunction?</li> </ul>	Yes	Repair or replace terminals, then go to Step 11.
		No	Go to next step.

## ON-BOARD DIAGNOSTIC [ENGINE CONTROL SYSTEM (ZM)]

STEP	INSPECTION	ACTION	
7	<b>INSPECT EGR VALVE</b> <ul style="list-style-type: none"> <li>Measure resistance between EGR valve terminals C and A (part-side).</li> <li>Is resistance <b>within 20—24 ohms</b>?</li> </ul>	Yes	Go to next step.
		No	Replace EGR valve, then go to Step 11.
8	<b>INSPECT PCM CONNECTOR FOR POOR CONNECTION</b> <ul style="list-style-type: none"> <li>Disconnect PCM connector.</li> <li>Check for poor connection at terminal 72 (damaged/pulled-out terminals, corrosion, etc.).</li> <li>Is there malfunction?</li> </ul>	Yes	Repair terminal, then go to Step 11.
		No	Go to next step.
9	<b>INSPECT CONTROL CIRCUIT FOR SHORT</b> <ul style="list-style-type: none"> <li>Check continuity between EGR valve terminal A (harness-side) and body ground.</li> <li>Is there continuity?</li> </ul>	Yes	Repair or replace harness for short to ground, then go to Step 11.
		No	Measure voltage between EGR valve terminal A and body ground. <ul style="list-style-type: none"> <li>If voltage is <b>B+</b>, repair or replace harness for short to power, then go to next step.</li> <li>If voltage is <b>approx. 0 V</b>, go to next step.</li> </ul>
10	<b>INSPECT CONTROL CIRCUIT FOR OPEN CIRCUIT</b> <ul style="list-style-type: none"> <li>Connect breakout box with PCM disconnected.</li> <li>Check for continuity between EGR valve terminal A (harness-side) and breakout box terminal 72.</li> <li>Is there continuity?</li> </ul>	Yes	Go to next step.
		No	Repair or replace harness for open, then go to next step.
11	<b>VERIFY TROUBLESHOOTING OF DTC P1497 COMPLETED</b> <ul style="list-style-type: none"> <li>Make sure to reconnect all disconnected connectors.</li> <li>Turn ignition key to OFF, then ON (Engine OFF).</li> <li>Is same DTC present?</li> </ul>	Yes	Replace PCM, then go to next step.
		No	Go to next step.
12	<b>VERIFY AFTER REPAIR PROCEDURE</b> <ul style="list-style-type: none"> <li>Perform "After Repair Procedure". (See 01-02A-10 AFTER REPAIR PROCEDURE [ZM].)</li> <li>Is there any DTC present?</li> </ul>	Yes	Go to applicable DTC inspection. (See 01-02A-15 DTC TABLE [ZM].)
		No	Troubleshooting completed.

01-02A

### DTC P1498 [ZM]

A3U010201083W29

DTC P1498	EGR valve stepping motor coil 3 open or short circuit
<b>DETECTION CONDITION</b>	<ul style="list-style-type: none"> <li>PCM monitors input voltages from EGR valve coil control circuit just after turning ignition key to ON. If voltage at PCM terminal 46 remains low or high, PCM determines that EGR valve circuit has malfunction.</li> </ul> <p><b>Diagnostic support note</b></p> <ul style="list-style-type: none"> <li>This is a diagnostic support DTC (monitored once per key cycle).</li> <li>MIL does not illuminate.</li> <li>FREEZE FRAME DATA is not available.</li> <li>DTC is not stored in PCM memory.</li> </ul>
<b>POSSIBLE CAUSE</b>	<ul style="list-style-type: none"> <li>EGR valve malfunction</li> <li>Connector or terminal malfunction</li> <li>Short to ground circuit in wiring between EGR valve terminal B and PCM terminal 46</li> <li>Open circuit in wiring between EGR valve terminal B and PCM terminal 46</li> <li>Short to power circuit in wiring between EGR valve terminal B and PCM terminal 46</li> <li>Open circuit in wiring between main relay terminal D and EGR valve terminal D</li> <li>PCM malfunction</li> </ul>

# ON-BOARD DIAGNOSTIC [ENGINE CONTROL SYSTEM (ZM)]

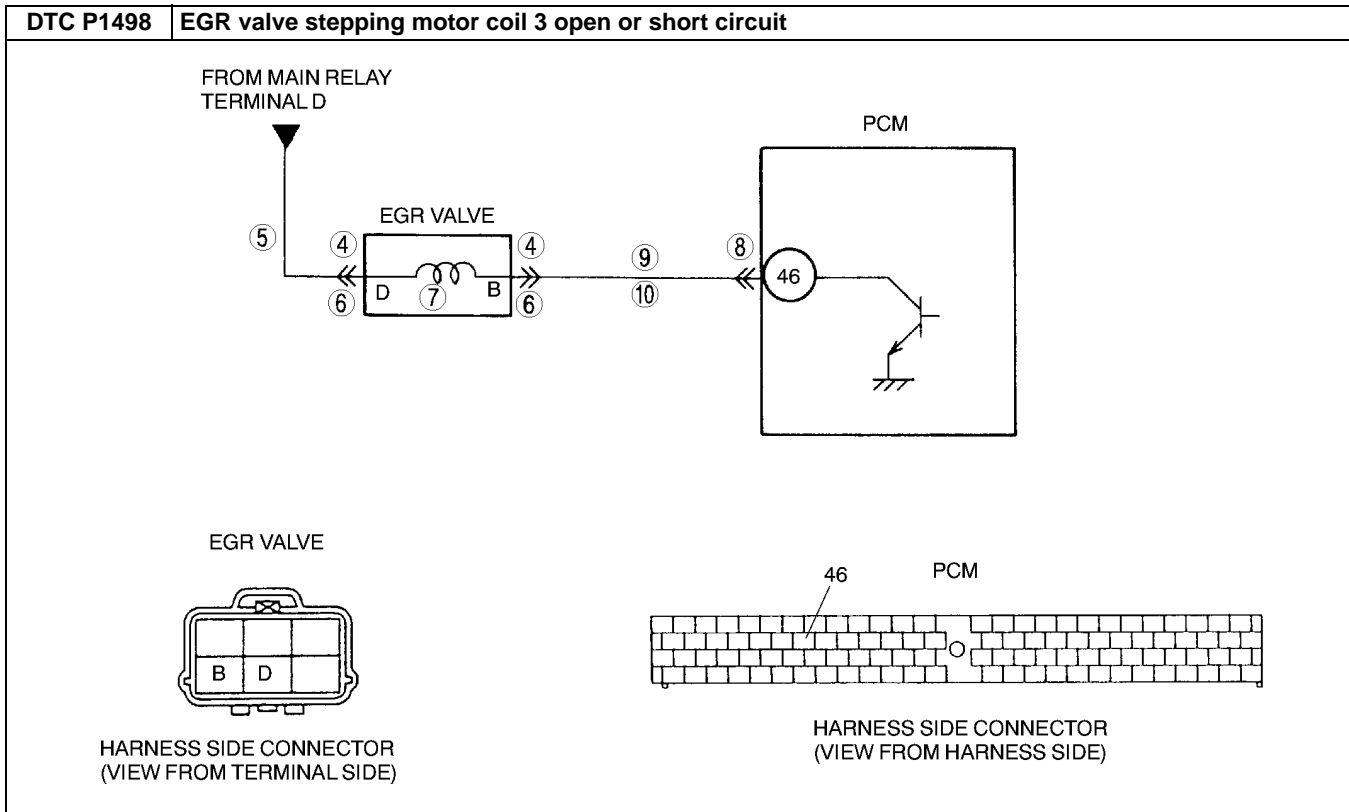

### Diagnostic procedure

STEP	INSPECTION		ACTION
1	<b>VERIFY RELATED REPAIR INFORMATION AVAILABILITY</b> <ul style="list-style-type: none"> <li>Check for related Service Bulletins availability.</li> <li>Is any repair information available?</li> </ul>	Yes	Perform repair or diagnosis according to available repair information. <ul style="list-style-type: none"> <li>If vehicle is not repaired, go to next step.</li> </ul>
		No	Go to next step.
2	<b>CLASSIFY INTERMITTENT CONCERN OR CONTINUOUS CONCERN</b> <ul style="list-style-type: none"> <li>Turn ignition key to OFF then ON (Engine OFF).</li> <li>Is same DTC present?</li> </ul>	Yes	Go to next step.
		No	Refer to intermittent concern. (See 01-03A-4 INTERMITTENT CONCERN TROUBLESHOOTING [ZM].)
3	<b>CLASSIFY POWER CIRCUIT OR CONTROL CIRCUIT MALFUNCTION</b> <ul style="list-style-type: none"> <li>Is same DTC and P1499 present?</li> </ul>	Yes	Malfunction at EGR valve or power circuit. Go to next step.
		No	Malfunction at EGR valve or control circuit. Go to Step 6.
4	<b>INSPECT EGR VALVE FOR POOR CONNECTION</b> <ul style="list-style-type: none"> <li>Turn ignition key to OFF.</li> <li>Disconnect EGR valve connector.</li> <li>Check for poor connection (damaged/pulled-out terminals, corrosion, etc.).</li> <li>Is there malfunction?</li> </ul>	Yes	Repair or replace terminals, then go to Step 11.
		No	Go to next step.
5	<b>INSPECT POWER CIRCUIT FOR OPEN CIRCUIT</b> <ul style="list-style-type: none"> <li>Turn ignition key to ON (Engine OFF).</li> <li>Measure voltage between EGR valve terminal D (harness-side) and body ground.</li> <li>Is voltage B+?</li> </ul>	Yes	Inspect EGR valve coils 3 and 4. (See 01-16-15 EGR VALVE INSPECTION.) <ul style="list-style-type: none"> <li>If there is a malfunction, replace EGR valve, and then go to Step 11.</li> <li>If there is no malfunction, go to Step 11.</li> </ul>
		No	Repair or replace harness for open circuit, then go to Step 11.
6	<b>INSPECT EGR VALVE FOR POOR CONNECTION</b> <ul style="list-style-type: none"> <li>Turn ignition key to OFF.</li> <li>Disconnect EGR valve connector.</li> <li>Check for poor connection (damaged/pulled-out terminals, corrosion, etc.).</li> <li>Is there malfunction?</li> </ul>	Yes	Repair or replace terminals, then go to Step 11.
		No	Go to next step.

## ON-BOARD DIAGNOSTIC [ENGINE CONTROL SYSTEM (ZM)]

STEP	INSPECTION	ACTION	
7	<b>INSPECT EGR VALVE</b> <ul style="list-style-type: none"> <li>Measure resistance between EGR valve terminals D and B (part-side).</li> <li>Is resistance <b>within 20—24 ohms</b>?</li> </ul>	Yes	Go to next step.
		No	Replace EGR valve, then go to Step 11.
8	<b>INSPECT PCM CONNECTOR FOR POOR CONNECTION</b> <ul style="list-style-type: none"> <li>Disconnect PCM connector.</li> <li>Check for poor connection at terminal 46 (damaged/pulled-out terminals, corrosion, etc.).</li> <li>Is there malfunction?</li> </ul>	Yes	Repair terminals, then go to Step 11.
		No	Go to next step.
9	<b>INSPECT CONTROL CIRCUIT FOR SHORT</b> <ul style="list-style-type: none"> <li>Check continuity between EGR valve terminal B (harness-side) and body ground.</li> <li>Is there continuity?</li> </ul>	Yes	Repair or replace harness for short to ground, then go to Step 11.
		No	Measure voltage between EGR valve terminal B and body ground. <ul style="list-style-type: none"> <li>If voltage is <b>B+</b>, repair or replace harness for short to power, then go to next step.</li> <li>If voltage is <b>approx. 0 V</b>, go to next step.</li> </ul>
10	<b>INSPECT CONTROL CIRCUIT FOR OPEN CIRCUIT</b> <ul style="list-style-type: none"> <li>Connect breakout box with PCM disconnected.</li> <li>Check for continuity between EGR valve terminal B (harness-side) and breakout box terminal 46.</li> <li>Is there continuity?</li> </ul>	Yes	Go to next step.
		No	Repair or replace harness for open, then go to next step.
11	<b>VERIFY TROUBLESHOOTING OF DTC P1498 COMPLETED</b> <ul style="list-style-type: none"> <li>Make sure to reconnect all disconnected connectors.</li> <li>Turn ignition key to OFF, then ON (Engine OFF).</li> <li>Is same DTC present?</li> </ul>	Yes	Replace PCM, then go to next step.
		No	Go to next step.
12	<b>VERIFY AFTER REPAIR PROCEDURE</b> <ul style="list-style-type: none"> <li>Perform "After Repair Procedure". (See 01-02A-10 AFTER REPAIR PROCEDURE [ZM].)</li> <li>Is there any DTC present?</li> </ul>	Yes	Go to applicable DTC inspection. (See 01-02A-15 DTC TABLE [ZM].)
		No	Troubleshooting completed.

01-02A

### DTC P1499 [ZM]

A3U010201083W30

DTC P1499	EGR valve stepping motor coil 4 open or short circuit
<b>DETECTION CONDITION</b>	<ul style="list-style-type: none"> <li>PCM monitors input voltages from EGR valve coil control circuit just after turning ignition key to ON. If voltage at PCM terminal 56 remains low or high, PCM determines that EGR valve circuit has malfunction.</li> </ul> <b>Diagnostic support note</b> <ul style="list-style-type: none"> <li>This is a diagnostic support DTC (monitored once per key cycle).</li> <li>MIL does not illuminate.</li> <li>FREEZE FRAME DATA is not available.</li> <li>DTC is not stored in PCM memory.</li> </ul>
<b>POSSIBLE CAUSE</b>	<ul style="list-style-type: none"> <li>EGR valve malfunction</li> <li>Connector or terminal malfunction</li> <li>Short to ground circuit in wiring between EGR valve terminal F and PCM terminal 56</li> <li>Open circuit in wiring between EGR valve terminal F and PCM terminal 56</li> <li>Short to power circuit in wiring between EGR valve terminal F and PCM terminal 56</li> <li>Open circuit in wiring between main relay terminal D and EGR valve terminal D</li> <li>PCM malfunction</li> </ul>

# ON-BOARD DIAGNOSTIC [ENGINE CONTROL SYSTEM (ZM)]

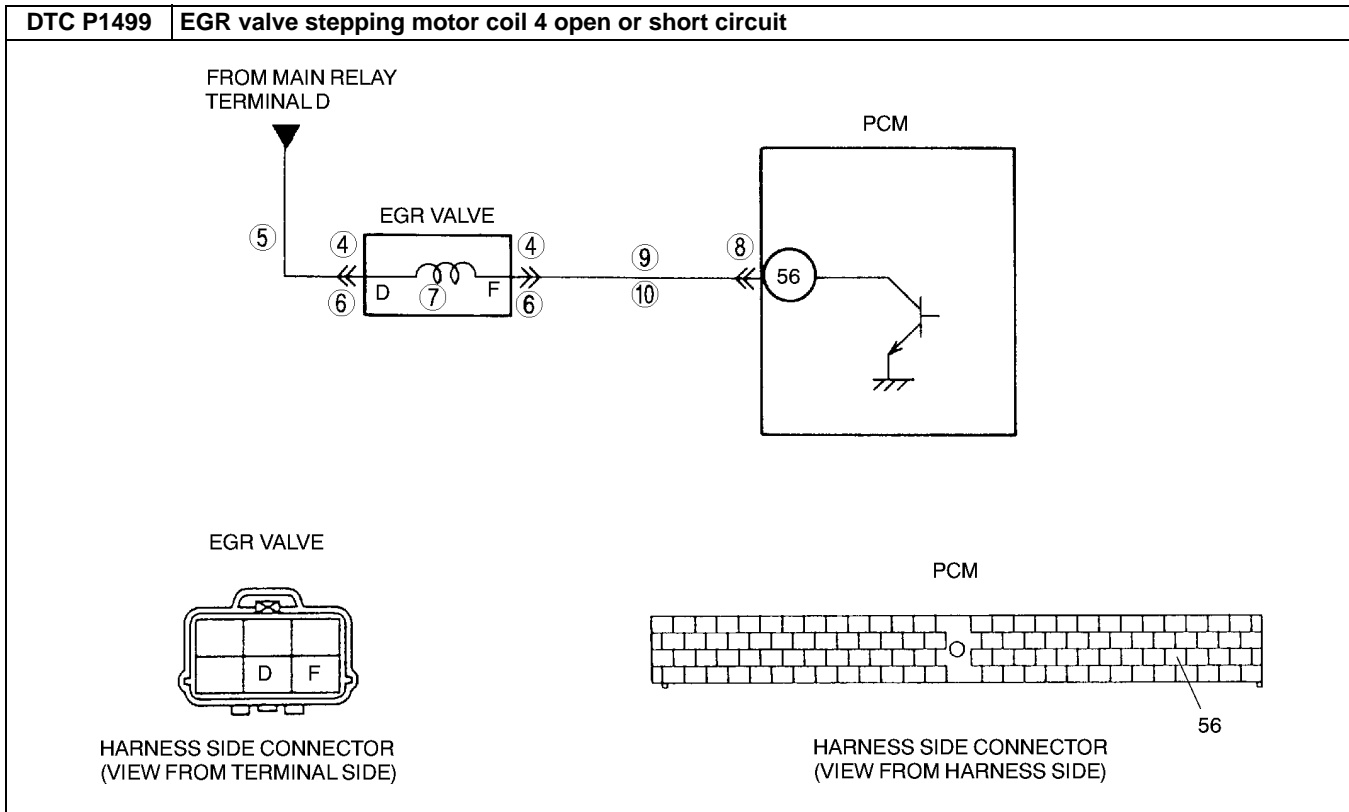

### Diagnostic procedure

STEP	INSPECTION		ACTION
1	<b>VERIFY RELATED REPAIR INFORMATION AVAILABILITY</b> <ul style="list-style-type: none"> <li>Check for related Service Bulletins availability.</li> <li>Is any repair information available?</li> </ul>	Yes	Perform repair or diagnosis according to available repair information. <ul style="list-style-type: none"> <li>If vehicle is not repaired, go to next step.</li> </ul>
		No	Go to next step.
2	<b>CLASSIFY INTERMITTENT CONCERN OR CONTINUOUS CONCERN</b> <ul style="list-style-type: none"> <li>Turn ignition key to OFF then ON (Engine OFF).</li> <li>Is same DTC present?</li> </ul>	Yes	Go to next step.
		No	Refer to intermittent concern. (See 01-03A-4 INTERMITTENT CONCERN TROUBLESHOOTING [ZM].)
3	<b>CLASSIFY POWER CIRCUIT OR CONTROL CIRCUIT MALFUNCTION</b> <ul style="list-style-type: none"> <li>Are same DTC and P1498 present?</li> </ul>	Yes	Malfunction at EGR valve or power circuit. Go to next step.
		No	Malfunction at EGR valve or control circuit. Go to Step 6.
4	<b>INSPECT EGR VALVE FOR POOR CONNECTION</b> <ul style="list-style-type: none"> <li>Turn ignition key to OFF.</li> <li>Disconnect EGR valve connector.</li> <li>Check for poor connection (damaged/pulled-out terminals, corrosion, etc.).</li> <li>Is there malfunction?</li> </ul>	Yes	Repair or replace terminals, then go to Step 11.
		No	Go to next step.
5	<b>INSPECT POWER CIRCUIT FOR OPEN CIRCUIT</b> <ul style="list-style-type: none"> <li>Turn ignition key to ON (Engine OFF).</li> <li>Measure voltage between EGR valve terminal D (harness-side) and body ground.</li> <li>Is voltage B+?</li> </ul>	Yes	Inspect EGR valve coils 3 and 4. (See 01-16-15 EGR VALVE INSPECTION.) <ul style="list-style-type: none"> <li>If there is a malfunction, replace EGR valve, and then go to Step 11.</li> <li>If there is no malfunction, go to Step 11.</li> </ul>
		No	Repair or replace harness for open circuit, then go to Step 11.
6	<b>INSPECT EGR VALVE FOR POOR CONNECTION</b> <ul style="list-style-type: none"> <li>Turn ignition key to OFF.</li> <li>Disconnect EGR valve connector.</li> <li>Check for poor connection (damaged/pulled-out terminals, corrosion, etc.).</li> <li>Is there malfunction?</li> </ul>	Yes	Repair or replace terminals, then go to Step 11.
		No	Go to next step.



## ON-BOARD DIAGNOSTIC [ENGINE CONTROL SYSTEM (ZM)]

STEP	INSPECTION	ACTION	
7	<b>INSPECT EGR VALVE</b> <ul style="list-style-type: none"> <li>Measure resistance between EGR valve terminal D and F (part-side).</li> <li>Is resistance <b>within 20—24 ohms</b>?</li> </ul>	Yes	Go to next step.
		No	Replace EGR valve, then go to Step 11.
8	<b>INSPECT PCM CONNECTOR FOR POOR CONNECTION</b> <ul style="list-style-type: none"> <li>Disconnect PCM connector.</li> <li>Check for poor connection at terminal 56 (damaged/pulled-out terminals, corrosion, etc.).</li> <li>Is there malfunction?</li> </ul>	Yes	Repair terminal, then go to Step 11.
		No	Go to next step.
9	<b>INSPECT CONTROL CIRCUIT FOR SHORT</b> <ul style="list-style-type: none"> <li>Check for continuity between EGR valve terminal F (harness-side) and body ground.</li> <li>Is there continuity?</li> </ul>	Yes	Repair or replace harness for short to ground, then go to Step 11.
		No	Measure voltage between EGR valve terminal F and body ground. <ul style="list-style-type: none"> <li>If voltage is <b>B+</b>, repair or replace harness for short to power, then go to next step.</li> <li>If voltage is <b>approx. 0 V</b>, go to next step.</li> </ul>
10	<b>INSPECT CONTROL CIRCUIT FOR OPEN CIRCUIT</b> <ul style="list-style-type: none"> <li>Connect breakout box with PCM disconnected.</li> <li>Check for continuity between EGR valve terminal F (harness-side) and breakout box terminal 56.</li> <li>Is there continuity?</li> </ul>	Yes	Go to next step.
		No	Repair or replace harness for open, then go to next step.
11	<b>VERIFY TROUBLESHOOTING OF DTC P1499 COMPLETED</b> <ul style="list-style-type: none"> <li>Make sure to reconnect all disconnected connectors.</li> <li>Turn ignition key to OFF, then ON (Engine OFF).</li> <li>Is same DTC present?</li> </ul>	Yes	Replace PCM, then go to next step.
		No	Go to next step.
12	<b>VERIFY AFTER REPAIR PROCEDURE</b> <ul style="list-style-type: none"> <li>Perform "After Repair Procedure". (See 01-02A-10 AFTER REPAIR PROCEDURE [ZM].)</li> <li>Is there any DTC present?</li> </ul>	Yes	Go to applicable DTC inspection. (See 01-02A-15 DTC TABLE [ZM].)
		No	Troubleshooting completed.

01-02A

### DTC P1504 [ZM]

A3U010201083W31

DTC P1504	IAC valve circuit malfunction
<b>DETECTION CONDITION</b>	<ul style="list-style-type: none"> <li>PCM monitors IAC valve circuit current while IAC duty is within <b>18—70%</b>. If PCM detects IAC valve circuit current <b>below 100 mA (25 °C {77 °F})</b> or <b>above 4.5 A (25 °C {77 °F})</b> for <b>1 second</b>, PCM determines that IAC valve circuit has malfunction.</li> </ul> <p><b>Diagnostic support note</b></p> <ul style="list-style-type: none"> <li>This is a continuous monitor (CCM).</li> <li>MIL illuminates if PCM detects the above malfunction condition during first drive cycle. Therefore, PENDING CODE is not available.</li> <li>FREEZE FRAME DATA is available.</li> <li>DTC is stored in PCM memory.</li> </ul>
<b>POSSIBLE CAUSE</b>	<ul style="list-style-type: none"> <li>IAC valve circuit malfunction</li> <li>Short to ground between IAC valve terminal A and PCM terminal 54</li> <li>Open circuit between IAC valve terminal A and PCM terminal 54</li> <li>Short to ground between IAC valve terminal B and PCM terminal 83</li> <li>Short to power between IAC valve terminal B and PCM terminal 83</li> <li>Open circuit between IAC valve terminal B and PCM terminal 83</li> <li>Poor connection of IAC valve connector or PCM connector</li> <li>PCM malfunction</li> </ul>

# ON-BOARD DIAGNOSTIC [ENGINE CONTROL SYSTEM (ZM)]

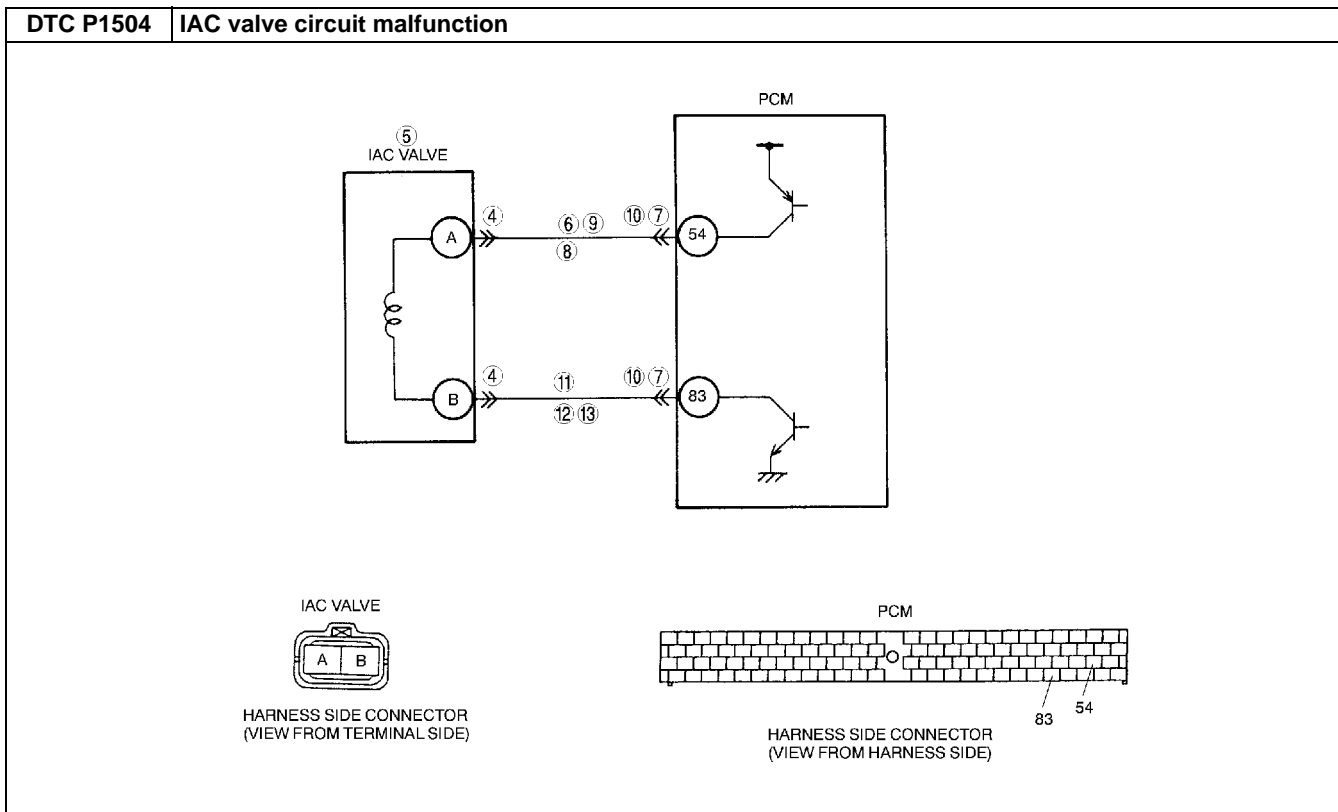

### Diagnostic procedure

STEP	INSPECTION		ACTION
1	<b>VERIFY FREEZE FRAME DATA HAS BEEN RECORDED</b> <ul style="list-style-type: none"> <li>Has FREEZE FRAME DATA been recorded?</li> </ul>	Yes	Go to next step.
		No	Record FREEZE FRAME DATA on repair order, then go to next step.
2	<b>VERIFY RELATED REPAIR INFORMATION AVAILABILITY</b> <ul style="list-style-type: none"> <li>Check for related Service Bulletins availability.</li> <li>Is any repair information available?</li> </ul>	Yes	Perform repair or diagnosis according to available repair information. <ul style="list-style-type: none"> <li>If vehicle is not repaired, go to next step.</li> </ul>
		No	Go to next step.
3	<b>CLASSIFY INTERMITTENT CONCERN OR CONTINUOUS CONCERN</b> <ul style="list-style-type: none"> <li>Clear DTC from PCM memory using WDS or equipment.</li> <li>Start engine and warm it up completely.</li> <li>Is same DTC detected?</li> </ul>	Yes	Go to next step.
		No	Go to intermittent concern. (See 01-03A-4 INTERMITTENT CONCERN TROUBLESHOOTING [ZM].)
4	<b>INSPECT IAC VALVE CONNECTOR FOR POOR CONNECTION</b> <ul style="list-style-type: none"> <li>Turn ignition key to OFF.</li> <li>Disconnect IAC valve connector.</li> <li>Check for poor connection (damaged/pulled-out terminals, corrosion, etc.).</li> <li>Is there malfunction?</li> </ul>	Yes	Repair or replace terminal, then go to Step 14.
		No	Go to next step.
5	<b>INSPECT IAC VALVE ELECTRICAL MALFUNCTION</b> <ul style="list-style-type: none"> <li>Measure resistance between IAC valve terminals A and B (part-side).</li> <li>Is resistance <b>within 8.7—10.5 ohms</b>?</li> </ul>	Yes	Go to next step.
		No	Replace IAC valve, then go to Step 14.
6	<b>CLASSIFY MALFUNCTION AT POWER SUPPLY CIRCUIT OR CONTROL CIRCUIT</b> <ul style="list-style-type: none"> <li>Turn ignition key to ON (Engine OFF).</li> <li>Measure voltage between IAC valve terminal A (harness-side) and body ground.</li> <li>Is voltage <b>B+</b>?</li> </ul>	Yes	Malfunction at control circuit. Go to Step 10.
		No	Malfunction at power supply circuit. Go to next step.

## ON-BOARD DIAGNOSTIC [ENGINE CONTROL SYSTEM (ZM)]

STEP	INSPECTION	ACTION	
7	<b>INSPECT PCM CONNECTOR FOR POOR CONNECTION</b> <ul style="list-style-type: none"> <li>• Turn ignition key to OFF.</li> <li>• Disconnect PCM connector.</li> <li>• Check for poor connection at terminal 54 (damaged/pulled-out terminals, corrosion, etc.).</li> <li>• Is there malfunction?</li> </ul>	Yes	Repair terminal, then go to Step 14.
		No	Go to next step.
8	<b>INSPECT POWER CIRCUIT FOR SHORT TO GROUND</b> <ul style="list-style-type: none"> <li>• Turn ignition key to OFF.</li> <li>• Check for continuity between IAC valve terminal A (harness-side) and body ground.</li> <li>• Is there continuity?</li> </ul>	Yes	Repair or replace harness for short to ground, then go to Step 14.
		No	Go to next step.
9	<b>INSPECT POWER CIRCUIT FOR OPEN CIRCUIT</b> <ul style="list-style-type: none"> <li>• Turn ignition key to OFF</li> <li>• Connect breakout box with PCM disconnected.</li> <li>• Check for continuity between IAC valve terminal A (harness-side) and breakout box terminal 54.</li> <li>• Is there continuity?</li> </ul>	Yes	Repair or replace harness for open circuit, then go to Step 14.
		No	Go to Step 14.
10	<b>INSPECT PCM CONNECTOR FOR POOR CONNECTION</b> <ul style="list-style-type: none"> <li>• Turn ignition key to OFF.</li> <li>• Disconnect PCM connector.</li> <li>• Check for poor connection at terminal 83 (damaged/pulled-out terminals, corrosion, etc.).</li> <li>• Is there malfunction?</li> </ul>	Yes	Repair terminal, then go to Step 14.
		No	Go to next step.
11	<b>INSPECT CONTROL CIRCUIT FOR SHORT TO POWER</b> <ul style="list-style-type: none"> <li>• Turn ignition key to ON (Engine OFF).</li> <li>• Measure voltage between IAC valve terminal B (harness-side) and body ground.</li> <li>• Is voltage <b>B+</b>?</li> </ul>	Yes	Repair or replace harness for short to power, then go to Step 14.
		No	Go to next step.
12	<b>INSPECT CONTROL CIRCUIT FOR SHORT TO GROUND</b> <ul style="list-style-type: none"> <li>• Turn ignition key to OFF.</li> <li>• Check for continuity between IAC valve terminal B (harness-side) and body ground.</li> <li>• Is there continuity?</li> </ul>	Yes	Repair or replace harness for short to ground, then go to Step 14.
		No	Go to next step.
13	<b>INSPECT CONTROL CIRCUIT MALFUNCTION FOR OPEN CIRCUIT</b> <ul style="list-style-type: none"> <li>• Connect breakout box with PCM disconnected.</li> <li>• Check for continuity between IAC valve terminal B (harness-side) and breakout box terminal 83.</li> <li>• Is there continuity?</li> </ul>	Yes	Repair or replace harness for open, then go to next step.
		No	Go to next step.
14	<b>VERIFY TROUBLESHOOTING OF DTC P1504 COMPLETED</b> <ul style="list-style-type: none"> <li>• Make sure to reconnect all disconnected connectors.</li> <li>• Clear DTC from PCM memory using WDS or equipment.</li> <li>• Start engine and warm it up completely.</li> <li>• Is same DTC present?</li> </ul>	Yes	Replace PCM, then go to next step.
		No	Go to next step.
15	<b>VERIFY AFTER REPAIR PROCEDURE</b> <ul style="list-style-type: none"> <li>• Perform "After Repair Procedure". (See 01-02A-10 AFTER REPAIR PROCEDURE [ZM].)</li> <li>• Is there any DTC present?</li> </ul>	Yes	Go to applicable DTC inspection. (See 01-02A-15 DTC TABLE [ZM].)
		No	Troubleshooting completed.

01-02A

# ON-BOARD DIAGNOSTIC [ENGINE CONTROL SYSTEM (ZM)]

**DTC P1512 [ZM]**

A3U010201083W32

<b>DTC P1512</b>	<b>Variable tumble control system (VTCS) shutter valve close stuck</b>
<b>DETECTION CONDITION</b>	<ul style="list-style-type: none"> <li>PCM monitors air flow amount is <b>above 30 g/s {4.0 lb/min}</b> when the following monitoring conditions are met. PCM determines that VTCS shutter valve has closed stuck malfunction.</li> </ul> <p><b>MONITORING CONDITIONS</b></p> <ul style="list-style-type: none"> <li>— Engine speed is <b>above 3,000 rpm</b>.</li> <li>— Engine coolant temperature is <b>above 80 °C {176 °F}</b>.</li> <li>— Throttle valve opening angle is <b>above 75%</b>.</li> </ul> <p><b>Diagnostic support note</b></p> <ul style="list-style-type: none"> <li>This is a continuous monitor (CCM).</li> <li>MIL illuminates if PCM detects the above the above malfunction condition in two consecutive drive cycles.</li> <li>PENDING CODE is available if PCM detects the above malfunction condition during first drive cycle.</li> <li>FREEZE FRAME DATA is available.</li> <li>DTC is stored in PCM memory.</li> </ul>
<b>POSSIBLE CAUSE</b>	<ul style="list-style-type: none"> <li>ECT sensor malfunction</li> <li>MAF sensor malfunction</li> <li>IAT sensor malfunction</li> <li>EGR boost sensor malfunction</li> <li>TP sensor malfunction</li> <li>CKP sensor malfunction</li> <li>VTCS solenoid valve malfunction</li> <li>VTCS shutter valve malfunction (stuck closed)</li> <li>VTCS shutter valve actuator malfunction (stuck closed).</li> <li>Short to ground circuit between VTCS solenoid valve terminal B and PCM terminal 19</li> <li>Short to power circuit between VTCS solenoid valve terminal B and PCM terminal 19</li> <li>PCM malfunction</li> </ul>

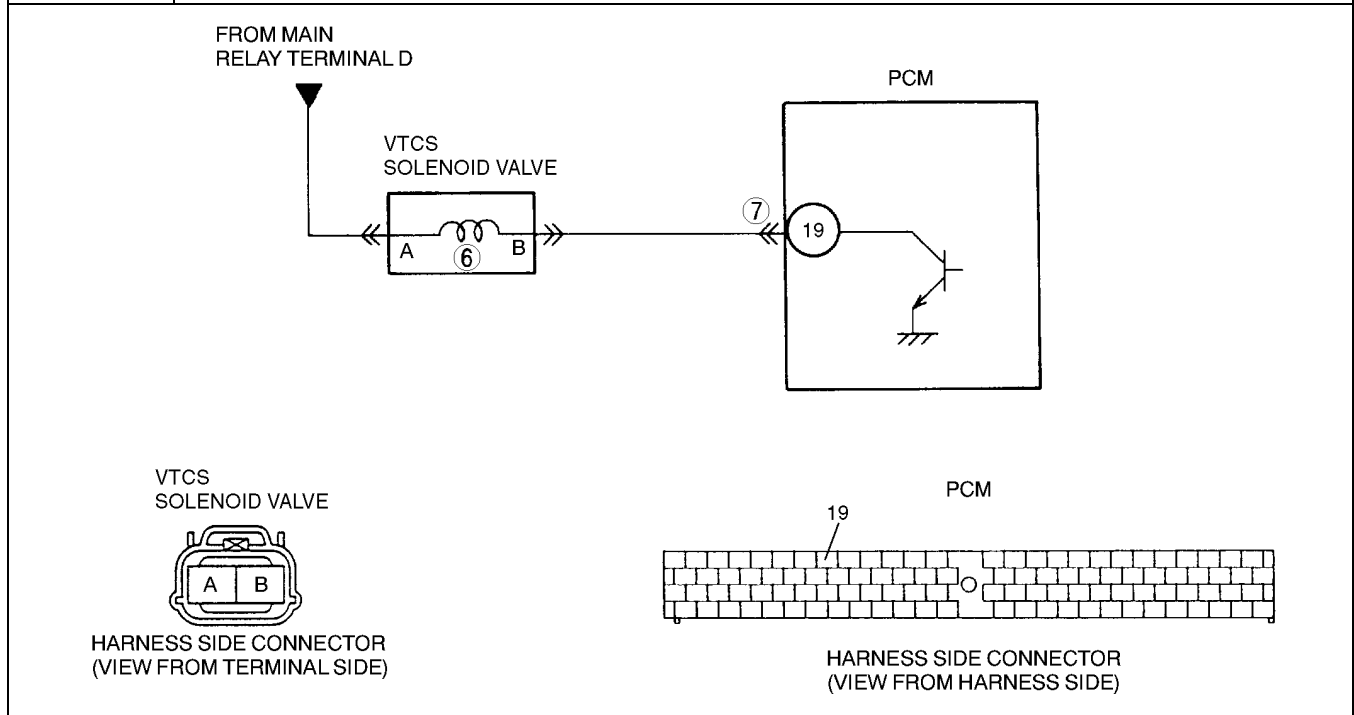

**Diagnostic procedure**

STEP	INSPECTION		ACTION
1	<b>CHECK FREEZE FRAME DATA HAS BEEN RECORDED</b> <ul style="list-style-type: none"> <li>Has FREEZE FRAME DATA been recorded?</li> </ul>	Yes	Go to next step.
		No	Record FREEZE FRAME DATA on repair order, then go to next step.
2	<b>CHECK RELATED REPAIR INFORMATION AVAILABILITY</b> <ul style="list-style-type: none"> <li>Check for related Service Bulletins availability.</li> <li>Is any related repair information available?</li> </ul>	Yes	Perform repair or diagnosis according to available repair information. <ul style="list-style-type: none"> <li>If vehicle is not repaired, go to next step.</li> </ul>
		No	Go to next step.

## ON-BOARD DIAGNOSTIC [ENGINE CONTROL SYSTEM (ZM)]

01-02A

STEP	INSPECTION		ACTION
3	<b>CLASSIFY INTERMITTENT CONCERN OR CONTINUOUS CONCERN</b> <ul style="list-style-type: none"> <li>Clear DTC from PCM memory using WDS or equipment.</li> <li>Verify that following conditions are met.                             <ul style="list-style-type: none"> <li>— ECT: <b>at 20 °C {68 °F}</b></li> </ul> </li> <li>Drive vehicle under following conditions:                             <ul style="list-style-type: none"> <li>— Engine speed: <b>above 3,000 rpm</b></li> <li>— MAF: <b>below 30 g/s {4.0 lb/min}</b></li> </ul> </li> <li>Is pending code of same DTC present?</li> </ul>	Yes	Go to next step.
		No	Intermittent concern exists. Go to INTERMITTENT CONCERN TROUBLESHOOTING procedure. (See 01-03A-4 INTERMITTENT CONCERN TROUBLESHOOTING [ZM].)
4	<b>VERIFY STORED OTHER DTCS</b> <ul style="list-style-type: none"> <li>Verify stored DTCs using WDS or equipment.</li> <li>Is other DTC present except P1512?</li> </ul>	Yes	Go to appropriate DTC troubleshooting procedures.
		No	Go to next step.
5	<b>INSPECT VTCS SHUTTER VALVE ACTUATOR</b> <ul style="list-style-type: none"> <li>Carry out "VTCS operation inspection" (See 01-03A-58 Variable Tumble Control System (VTCS) Inspection.)</li> <li>Is VTCS shutter valve actuator okay?</li> </ul>	Yes	Go to next step.
		No	Replace VTCS shutter valve actuator, then go to Step 8.
6	<b>INSPECT VTCS SOLENOID VALVE</b> <ul style="list-style-type: none"> <li>Carry out "VTCS solenoid valve airflow inspection" (See 01-13A-11 VARIABLE TUMBLE CONTROL SYSTEM (VTCS) SOLENOID VALVE INSPECTION [ZM].)</li> <li>Is VTCS solenoid valve okay?</li> </ul>	Yes	Go to next step.
		No	Replace VTCS solenoid valve, then go to Step 8.
7	<b>CHECK PCM FOR POOR CONNECTION</b> <ul style="list-style-type: none"> <li>Check for poor connection at PCM terminal 19 (damaged/pulled-out terminals, corrosion, etc.).</li> <li>Is there malfunction?</li> </ul>	Yes	Repair terminal, then go to next step.
		No	Go to next step.
8	<b>VERIFY TROUBLESHOOTING OF DTC P1512 COMPLETED</b> <ul style="list-style-type: none"> <li>Make sure to reconnect all disconnected connectors.</li> <li>Start engine.</li> <li>Clear DTC from PCM memory using WDS or equipment.</li> <li>Start engine.</li> <li>Verify that following conditions are met.                             <ul style="list-style-type: none"> <li>— ECT: <b>at 20 °C {68 °F}</b></li> </ul> </li> <li>Drive vehicle under following conditions:                             <ul style="list-style-type: none"> <li>— Engine speed: <b>above 3,000 rpm</b></li> <li>— MAF: <b>below 30 g/s {4.0 lb/min}</b></li> </ul> </li> <li>Is pending code of same DTC present?</li> </ul>	Yes	Replace PCM, then go to next step.
		No	Go to next step.
9	<b>VERIFY AFTER REPAIR PROCEDURE</b> <ul style="list-style-type: none"> <li>Perform "After Repair Procedure". (See 01-02A-10 AFTER REPAIR PROCEDURE [ZM].)</li> <li>Is there any DTC present?</li> </ul>	Yes	Go to applicable DTC inspection. (See 01-02A-15 DTC TABLE [ZM].)
		No	Troubleshooting completed.

### DTC P1562 [ZM]

A3U010201083W33

DTC P1562	PCM +BB voltage low
<b>DETECTION CONDITION</b>	<ul style="list-style-type: none"> <li>PCM monitors voltage of backup battery positive terminal at PCM terminal 55 after engine is started. If the PCM detected battery positive terminal voltage <b>below 2.5 V for 2 seconds</b>, PCM determines that backup voltage circuit has malfunction.</li> </ul> <p><b>Diagnostic support note</b></p> <ul style="list-style-type: none"> <li>This is a continuous monitor (CCM).</li> <li>MIL illuminates if PCM detects the above malfunction condition during first drive cycle. Therefore, PENDING CODE is not available.</li> <li>FREEZE FRAME DATA is available.</li> <li>DTC is stored in PCM memory.</li> </ul>
<b>POSSIBLE CAUSE</b>	<ul style="list-style-type: none"> <li>Open circuit or short to ground in wiring between battery positive terminal and PCM terminal 55</li> <li>Poor connection of PCM connector</li> <li>PCM malfunction</li> </ul>

# ON-BOARD DIAGNOSTIC [ENGINE CONTROL SYSTEM (ZM)]

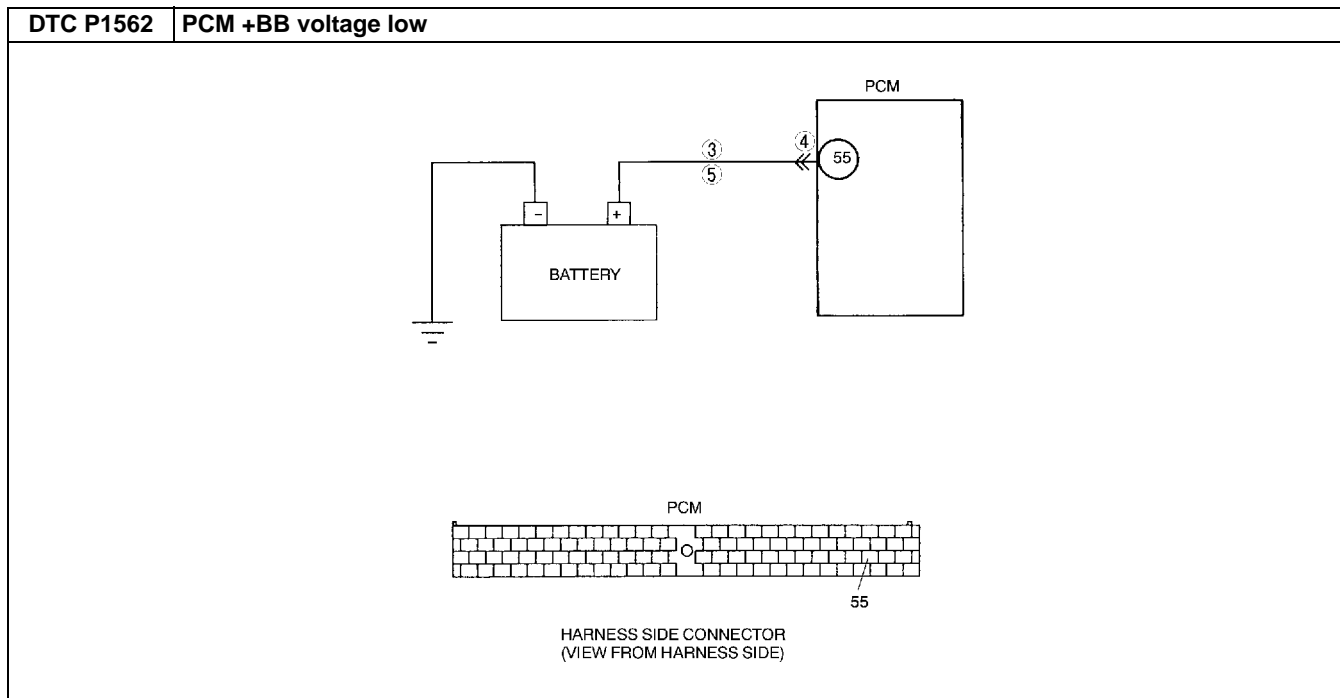

## Diagnostic procedure

STEP	INSPECTION		ACTION
1	<b>VERIFY FREEZE FRAME DATA HAS BEEN RECORDED</b> <ul style="list-style-type: none"> <li>• Has FREEZE FRAME DATA been recorded?</li> </ul>	Yes	Go to next step.
		No	Record FREEZE FRAME DATA on repair order, then go to next step.
2	<b>VERIFY RELATED REPAIR INFORMATION AVAILABILITY</b> <ul style="list-style-type: none"> <li>• Check for related Service Bulletins availability.</li> <li>• Is any repair information available?</li> </ul>	Yes	Perform repair or diagnosis according to available repair information. <ul style="list-style-type: none"> <li>• If vehicle is not repaired, then go to next step.</li> </ul>
		No	Go to next step.
3	<b>INSPECT MONITOR CIRCUIT FOR SHORT TO GROUND</b> <ul style="list-style-type: none"> <li>• Disconnect both battery cables.</li> <li>• Measure resistance between battery positive cable and body ground.</li> <li>• Is resistance more than <b>500 ohms</b>?</li> </ul>	Yes	Go to next step.
		No	Repair or replace harness between battery positive left terminal and PCM terminal 55 for short to ground, then go to Step 6.
4	<b>INSPECT PCM CONNECTOR FOR POOR CONNECTION</b> <ul style="list-style-type: none"> <li>• Disconnect PCM connector.</li> <li>• Check for poor connection at terminal 55 (damaged/pulled-out terminals, corrosion, etc.).</li> <li>• Is there malfunction?</li> </ul>	Yes	Repair terminals, then go to Step 6.
		No	Go to next step.
5	<b>INSPECT MONITOR CIRCUIT FOR OPEN CIRCUIT</b> <ul style="list-style-type: none"> <li>• Disconnect battery cables.</li> <li>• Connect breakout box with PCM disconnected.</li> <li>• Check for continuity between battery positive cable and breakout box terminal 55.</li> <li>• Is there continuity?</li> </ul>	Yes	Go to next step.
		No	Repair or replace harness for open, then go to next step.
6	<b>VERIFY TROUBLESHOOTING OF DTC P1562 COMPLETED</b> <ul style="list-style-type: none"> <li>• Make sure to reconnect all disconnected connectors.</li> <li>• Clear DTC using WDS or equivalent.</li> <li>• Turn ignition key to OFF, then start engine.</li> <li>• Is same DTC present?</li> </ul>	Yes	Replace PCM, then go to next step.
		No	Go to next step.
7	<b>VERIFY AFTER REPAIR PROCEDURE</b> <ul style="list-style-type: none"> <li>• Perform "After Repair Procedure". (See 01-02A-10 AFTER REPAIR PROCEDURE [ZM].)</li> <li>• Is there any DTC present?</li> </ul>	Yes	Go to applicable DTC inspection. (See 01-02A-15 DTC TABLE [ZM].)
		No	Troubleshooting completed.

# ON-BOARD DIAGNOSTIC [ENGINE CONTROL SYSTEM (ZM)]

**DTC P1569 [ZM]**

A3U010201083W34

01-02A

<b>DTC P1569</b>	<b>Variable tumble control system (VTCS) solenoid valve circuit low input</b>
<b>DETECTION CONDITION</b>	<ul style="list-style-type: none"> <li>PCM monitors input voltages from VTCS solenoid valve. If voltage at PCM 19 is low when VTCS solenoid valve OFF, PCM determines that VTCS solenoid valve has malfunction.</li> </ul> <p><b>Diagnostic support note</b></p> <ul style="list-style-type: none"> <li>This is a continuous monitor (CCM).</li> <li>MIL illuminates if PCM detects the above the above malfunction condition in two consecutive drive cycles.</li> <li>PENDING CODE is available if PCM detects the above malfunction condition during first drive cycle.</li> <li>FREEZE FRAME DATA is available.</li> <li>DTC is stored in PCM memory.</li> </ul>
<b>POSSIBLE CAUSE</b>	<ul style="list-style-type: none"> <li>Poor connection of connectors at PCM and/or VTCS solenoid valve</li> <li>Short to ground in wiring between VTCS solenoid valve terminal B and PCM terminal 19</li> <li>Open circuit in wiring between main relay terminal D and VTCS solenoid valve terminal A</li> <li>Open circuit in wiring between VTCS solenoid valve terminal B and PCM terminal 19</li> <li>VTCS solenoid valve malfunction</li> <li>PCM malfunction</li> </ul>

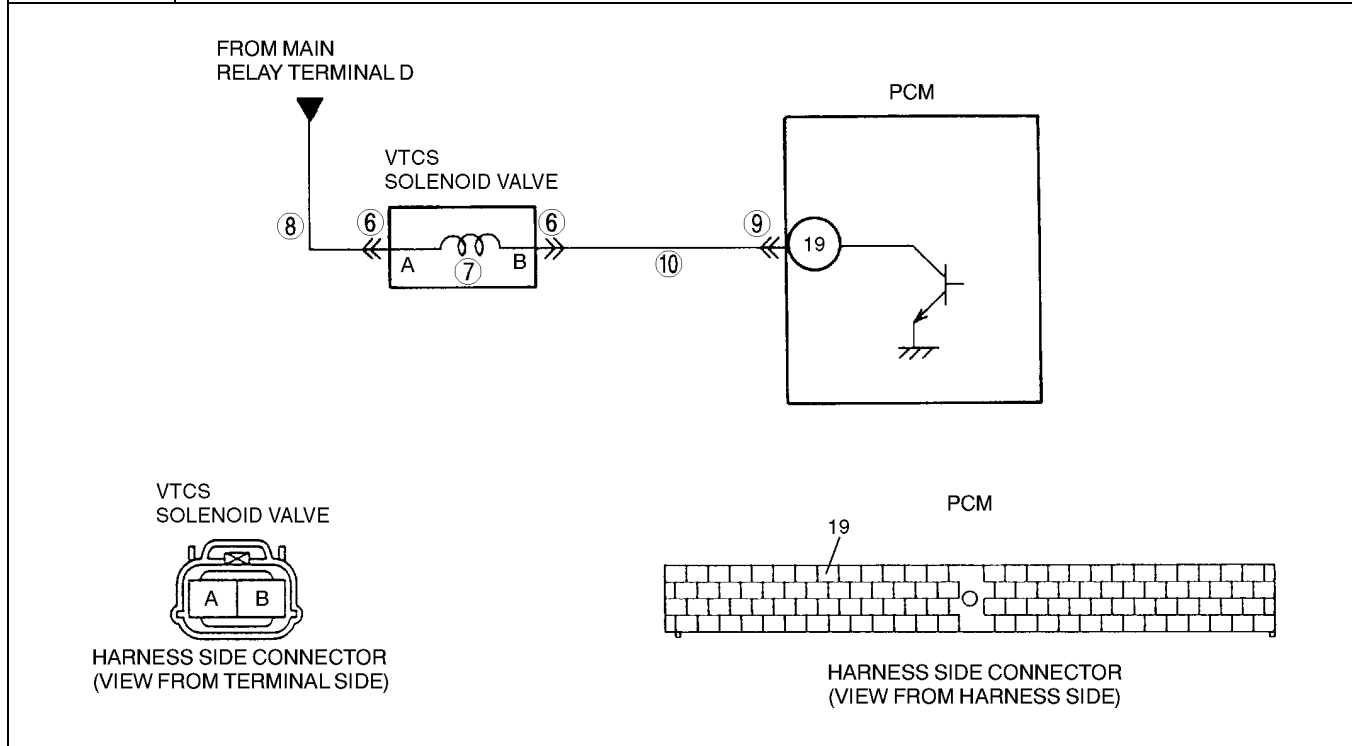

**Diagnostic procedure**

STEP	INSPECTION		ACTION
1	<b>CHECK FREEZE FRAME DATA HAS BEEN RECORDED</b> <ul style="list-style-type: none"> <li>Has FREEZE FRAME DATA been recorded?</li> </ul>	Yes	Go to next step.
		No	Record FREEZE FRAME DATA on repair order, then go to next step.
2	<b>VERIFY RELATED REPAIR INFORMATION AVAILABILITY</b> <ul style="list-style-type: none"> <li>Check for related Service Bulletins availability.</li> <li>Is any related repair information available?</li> </ul>	Yes	Perform repair or diagnosis according to available repair information. <ul style="list-style-type: none"> <li>If vehicle is not repaired, go to next step.</li> </ul>
		No	Go to next step.
3	<b>CLASSIFY INTERMITTENT CONCERN OR CONTINUOUS CONCERN</b> <ul style="list-style-type: none"> <li>Clear DTC from PCM memory using WDS or equipment.</li> <li>Start engine and warm it up completely.</li> <li>Is pending code of same DTC present?</li> </ul>	Yes	Go to next step.
		No	Intermittent concern exists. Go to INTERMITTENT CONCERN TROUBLESHOOTING procedure. (See 01-03A-4 INTERMITTENT CONCERN TROUBLESHOOTING [ZM].)

## ON-BOARD DIAGNOSTIC [ENGINE CONTROL SYSTEM (ZM)]

STEP	INSPECTION	ACTION	
4	<b>CLASSIFY OPEN CIRCUIT OR SHORT TO GROUND MALFUNCTION</b> <ul style="list-style-type: none"> <li>• Disconnect VTCS solenoid valve tube that connects to intake manifold.</li> <li>• Connect vacuum pump to VTCS solenoid valve.</li> <li>• Apply vacuum and wait <b>5 seconds</b>.</li> <li>• Is vacuum maintained?</li> </ul>	Yes	Go to Step 6.
		No	Go to next step.
5	<b>INSPECT PASSAGE CONTROL OF VTCS SOLENOID VALVE</b> <ul style="list-style-type: none"> <li>• Turn ignition key to OFF.</li> <li>• Disconnect VTCS solenoid valve connector.</li> <li>• Is vacuum maintained?</li> </ul>	Yes	Repair or replace harness between PCM terminal 19 and VTCS solenoid valve terminal B for short to ground, then go to Step 11.
		No	Replace VTCS solenoid valve, then go to Step 11.
6	<b>INSPECT VTCS SOLENOID VALVE CONNECTOR FOR POOR CONNECTION</b> <ul style="list-style-type: none"> <li>• Turn ignition key to OFF.</li> <li>• Check for poor connection (damaged/pulled-out pins, corrosion, etc.).</li> <li>• Is there malfunction?</li> </ul>	Yes	Repair or replace terminal, then go to Step 11.
		No	Go to next step.
7	<b>INSPECT VTCS SOLENOID VALVE</b> <ul style="list-style-type: none"> <li>• Measure resistance between VTCS solenoid valve terminals (part-side).</li> <li>• Is resistance <b>within 22—26 ohms</b>?</li> </ul>	Yes	Go to next step.
		No	Replace VTCS solenoid valve, then go to Step 11.
8	<b>INSPECT VTCS SOLENOID VALVE POWER SUPPLY CIRCUIT FOR OPEN CIRCUIT</b> <ul style="list-style-type: none"> <li>• Disconnect VTCS solenoid valve connector.</li> <li>• Turn ignition key to ON (Engine OFF).</li> <li>• Measure voltage between VTCS solenoid valve terminal A (harness-side) and body ground.</li> <li>• Is voltage <b>B+</b>?</li> </ul>	Yes	Go to next step.
		No	Repair or replace harness for open, then go to Step 11.
9	<b>INSPECT PCM CONNECTOR FOR POOR CONNECTION</b> <ul style="list-style-type: none"> <li>• Turn ignition key to OFF.</li> <li>• Disconnect PCM connector.</li> <li>• Check for poor connection at PCM terminal 19. (damaged/pulled-out pins, corrosion, etc.).</li> <li>• Is there malfunction?</li> </ul>	Yes	Repair terminal, then go to Step 11.
		No	Go to next step.
10	<b>INSPECT VTCS SOLENOID VALVE CONTROL CIRCUIT FOR OPEN CIRCUIT</b> <ul style="list-style-type: none"> <li>• Connect VTCS solenoid valve connector.</li> <li>• Connect breakout box with PCM disconnected.</li> <li>• Turn ignition key to ON (Engine OFF).</li> <li>• Measure voltage between breakout box terminal 19 and body ground.</li> <li>• Is voltage <b>B+</b>?</li> </ul>	Yes	Go to next step.
		No	Repair or replace harness for open or short to ground circuit, then go to next step.
11	<b>VERIFY TROUBLESHOOTING OF DTC P1569 COMPLETED</b> <ul style="list-style-type: none"> <li>• Make sure to reconnect all disconnected connectors.</li> <li>• Clear DTC from PCM memory using WDS or equipment.</li> <li>• Start engine.</li> <li>• Verify that following conditions are met. <ul style="list-style-type: none"> <li>— ECT: <b>above 65 °C {149 °F}</b></li> <li>— Engine speed: <b>below 3,250 rpm</b></li> </ul> </li> <li>• Is pending code of same DTC present?</li> </ul>	Yes	Replace PCM, then go to next step.
		No	Go to next step.
12	<b>VERIFY AFTER REPAIR PROCEDURE</b> <ul style="list-style-type: none"> <li>• Perform "After Repair Procedure". (See 01-02A-10 AFTER REPAIR PROCEDURE [ZM].)</li> <li>• Is there any DTC present?</li> </ul>	Yes	Go to applicable DTC inspection. (See 01-02A-15 DTC TABLE [ZM].)
		No	Troubleshooting completed.



# ON-BOARD DIAGNOSTIC [ENGINE CONTROL SYSTEM (ZM)]

DTC P1570 [ZM]

A3U010201083W35

01-02A

<b>DTC P1570</b>	<b>Variable tumble control system (VTCS) solenoid valve circuit high input</b>
<b>DETECTION CONDITION</b>	<ul style="list-style-type: none"> <li>PCM monitors input voltages from VTCS solenoid valve. If voltage at PCM 19 is high when the VTCS solenoid valve ON, PCM determines that VTCS solenoid valve malfunction.</li> </ul> <p><b>MONITORING CONDITIONS</b></p> <ul style="list-style-type: none"> <li>— Engine speed is <b>below 3,250 rpm</b>.</li> <li>— Engine coolant temperature is <b>below 65°C {149 °F}</b>.</li> <li>— Throttle valve opening angle is <b>below 14% for ATX, 12.50% for MTX [at engine speed 2,500 rpm]</b>.</li> </ul> <p><b>Diagnostic support note</b></p> <ul style="list-style-type: none"> <li>This is a continuous monitor (CCM).</li> <li>MIL illuminates if PCM detects the above the above malfunction condition in two consecutive drive cycles.</li> <li>PENDING CODE is available if PCM detects the above malfunction condition during first drive cycle.</li> <li>FREEZE FRAME DATA is available.</li> <li>DTC is stored in PCM memory.</li> </ul>
<b>POSSIBLE CAUSE</b>	<ul style="list-style-type: none"> <li>Poor connection of connectors at PCM and/or VTCS solenoid valve</li> <li>Short to power circuit in wiring between VTCS solenoid valve terminal B and PCM terminal 19</li> <li>Open circuit in wiring between main relay terminal D and VTCS solenoid valve terminal A</li> <li>Open circuit in wiring between VTCS solenoid valve terminal B and PCM terminal 19</li> <li>VTCS solenoid valve malfunction</li> <li>PCM malfunction</li> </ul>

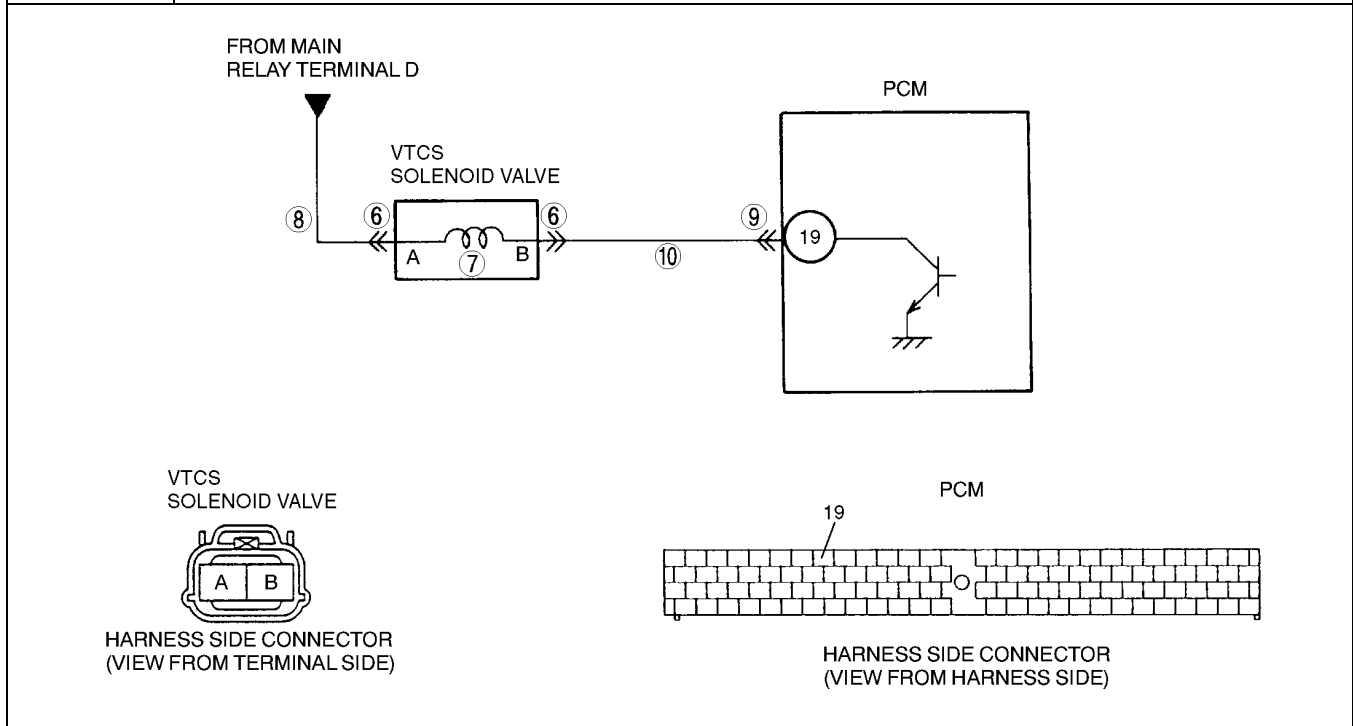

**Diagnostic procedure**

STEP	INSPECTION		ACTION
1	<b>CHECK FREEZE FRAME DATA HAS BEEN RECORDED</b> <ul style="list-style-type: none"> <li>Has FREEZE FRAME DATA been recorded?</li> </ul>	Yes	Go to next step.
		No	Record FREEZE FRAME DATA on repair order, then go to next step.
2	<b>VERIFY RELATED REPAIR INFORMATION AVAILABILITY</b> <ul style="list-style-type: none"> <li>Check for related Service Bulletins availability.</li> <li>Is any related repair information available?</li> </ul>	Yes	Perform repair or diagnosis according to available repair information. <ul style="list-style-type: none"> <li>If vehicle is not repaired, go to next step.</li> </ul>
		No	Go to next step.

## ON-BOARD DIAGNOSTIC [ENGINE CONTROL SYSTEM (ZM)]

STEP	INSPECTION	ACTION	
3	<b>CLASSIFY INTERMITTENT CONCERN OR CONTINUOUS CONCERN</b> <ul style="list-style-type: none"> <li>• Clear DTC from PCM memory using WDS or equipment.</li> <li>• Start engine.</li> <li>• Drive vehicle under following conditions: <ul style="list-style-type: none"> <li>— Engine speed is <b>below 3,250 rpm</b>.</li> <li>— Engine coolant temperature is <b>below 65°C {149 °F}</b>.</li> <li>— Throttle valve opening angle is <b>below 14% for ATX, 12.50% for MTX [at engine speed 2,500 rpm]</b>.</li> </ul> </li> <li>• Is pending code of same DTC present?</li> </ul>	Yes	Go to next step.
		No	Intermittent concern exists. Go to INTERMITTENT CONCERN TROUBLESHOOTING procedure. (See 01–03A–4 INTERMITTENT CONCERN TROUBLESHOOTING [ZM].)
4	<b>CLASSIFY OPEN CIRCUIT OR SHORT TO GROUND MALFUNCTION</b> <ul style="list-style-type: none"> <li>• Disconnect VTCS solenoid valve tube that connects to intake manifold.</li> <li>• Connect vacuum pump to VTCS solenoid valve.</li> <li>• Apply vacuum and wait <b>5 seconds</b>.</li> <li>• Is vacuum maintained?</li> </ul>	Yes	Go to Step 6.
		No	Go to next step.
5	<b>INSPECT VTCS SOLENOID VALVE FOR PASSAGE CONTROL</b> <ul style="list-style-type: none"> <li>• Turn ignition key to OFF.</li> <li>• Disconnect VTCS solenoid valve connector.</li> <li>• Is vacuum maintained?</li> </ul>	Yes	Repair or replace harness between PCM terminal 19 and VTCS solenoid valve terminal B for short to ground, then go to Step 11.
		No	Replace VTCS solenoid valve, then go to Step 11.
6	<b>INSPECT POOR CONNECTION OF VTCS SOLENOID VALVE CONNECTOR</b> <ul style="list-style-type: none"> <li>• Turn ignition key to OFF.</li> <li>• Check for poor connection (damaged/pulled-out pins, corrosion, etc.).</li> <li>• Is there malfunction?</li> </ul>	Yes	Repair or replace terminal, then go to Step 11.
		No	Go to next step.
7	<b>INSPECT VTCS SOLENOID VALVE</b> <ul style="list-style-type: none"> <li>• Measure resistance between VTCS solenoid valve terminals (part-side).</li> <li>• Is resistance <b>within 22—26 ohms</b>?</li> </ul>	Yes	Go to next step.
		No	Replace VTCS solenoid valve, then go to Step 11.
8	<b>INSPECT VTCS SOLENOID VALVE POWER SUPPLY CIRCUIT FOR OPEN CIRCUIT</b> <ul style="list-style-type: none"> <li>• Disconnect VTCS solenoid valve connector.</li> <li>• Turn ignition key to ON (Engine OFF).</li> <li>• Measure voltage between VTCS solenoid valve terminal A (harness-side) and body ground.</li> <li>• Is voltage <b>B+</b>?</li> </ul>	Yes	Go to next step.
		No	Repair or replace harness for open, then go to Step 11.
9	<b>INSPECT PCM CONNECTOR FOR POOR CONNECTION</b> <ul style="list-style-type: none"> <li>• Turn ignition key to OFF.</li> <li>• Disconnect PCM connector.</li> <li>• Check for poor connection at PCM terminal 19. (damaged/pulled-out pins, corrosion, etc.).</li> <li>• Is there malfunction?</li> </ul>	Yes	Repair terminal, then go to Step 11.
		No	Go to next step.
10	<b>INSPECT VTCS SOLENOID VALVE CONTROL CIRCUIT FOR SHORT TO POWER</b> <ul style="list-style-type: none"> <li>• Disconnect VTCS solenoid valve connector.</li> <li>• Connect breakout box with PCM disconnected.</li> <li>• Turn ignition key to ON (Engine OFF).</li> <li>• Measure voltage between breakout box terminal 19 and body ground.</li> <li>• Is voltage <b>B+</b>?</li> </ul>	Yes	Repair or replace harness for short to power circuit, then go to next step.
		No	Go to next step.

# ON-BOARD DIAGNOSTIC [ENGINE CONTROL SYSTEM (ZM)]

01-02A

STEP	INSPECTION		ACTION
11	<b>VERIFY TROUBLESHOOTING OF DTC P1570 COMPLETED</b> <ul style="list-style-type: none"> <li>Make sure to reconnect all disconnected connectors.</li> <li>Clear DTC from PCM memory using WDS or equipment.</li> <li>Start engine.</li> <li>Drive vehicle under following conditions:                             <ul style="list-style-type: none"> <li>— Engine speed is <b>below 3,250 rpm</b>.</li> <li>— Engine coolant temperature is <b>below 65 °C {149 °F}</b>.</li> <li>— Throttle valve opening angle is <b>below 14% for ATX, 12.50% for MTX [at engine speed 2,500 rpm]</b>.</li> </ul> </li> <li>Is pending code of same DTC present?</li> </ul>	Yes	Replace PCM, then go to next step.
		No	Go to next step.
12	<b>VERIFY AFTER REPAIR PROCEDURE</b> <ul style="list-style-type: none"> <li>Perform "After Repair Procedure". (See 01-02A-10 AFTER REPAIR PROCEDURE [ZM].)</li> <li>Is there any DTC present?</li> </ul>	Yes	Go to applicable DTC inspection. (See 01-02A-15 DTC TABLE [ZM].)
		No	Troubleshooting completed.

## DTC P1631 [ZM]

A3U010201083W36

DTC P1631	Generator output voltage signal no electricity
<b>DETECTION CONDITION</b>	<ul style="list-style-type: none"> <li>PCM monitors input voltage from generator. If PCM detect generator output voltage <b>below 8.5 V</b> or generated current <b>above 19.5 A</b> for <b>5 seconds</b> while engine running, PCM determines that charging system has malfunction.</li> </ul>
<b>POSSIBLE CAUSE</b>	<ul style="list-style-type: none"> <li>Open or short to ground circuit between generator terminal P and PCM terminal 30</li> <li>Open or short to ground circuit between generator terminal D and PCM terminal 53</li> <li>Drive belt is cut off or has come off</li> <li>Generator malfunction                             <ul style="list-style-type: none"> <li>— Rectifier circuit malfunction</li> <li>— Brush abrasion</li> </ul> </li> <li>PCM malfunction</li> </ul>

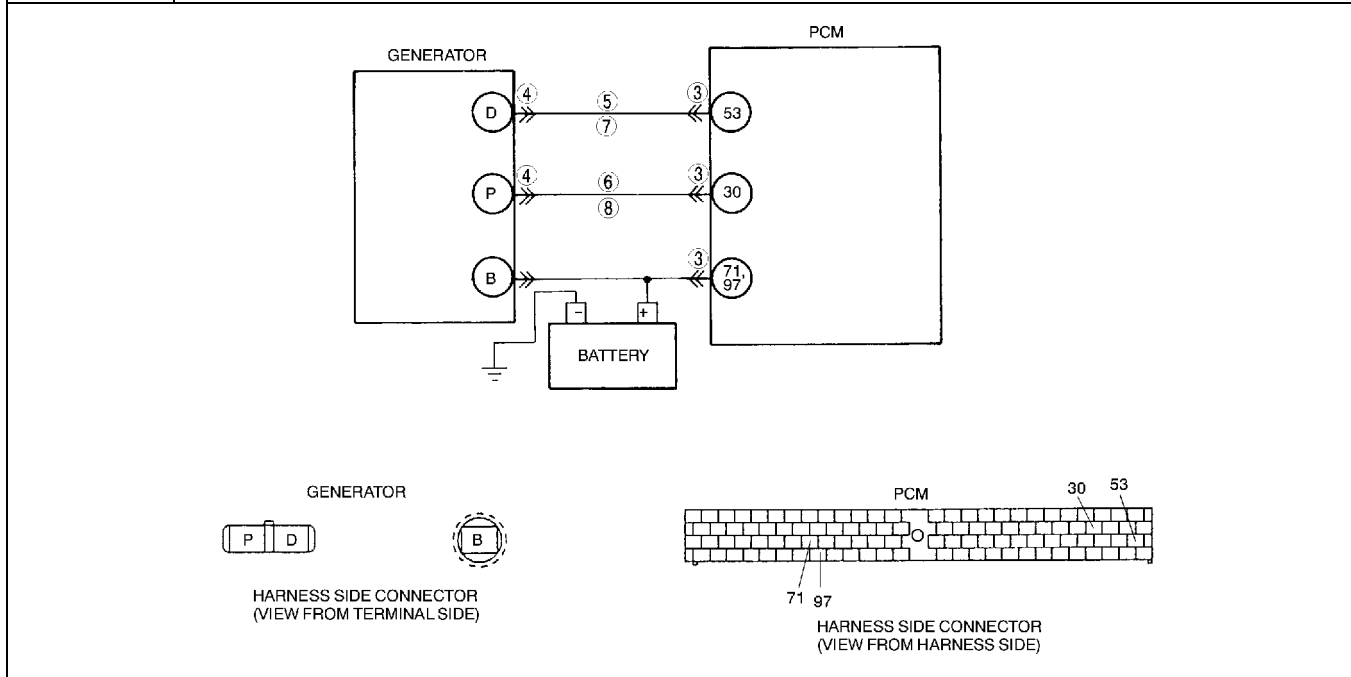

## ON-BOARD DIAGNOSTIC [ENGINE CONTROL SYSTEM (ZM)]

### Diagnostic procedure

STEP	INSPECTION	ACTION	
1	<b>VERIFY RELATED REPAIR INFORMATION AVAILABILITY</b> <ul style="list-style-type: none"> <li>• Check for related Service Bulletins availability.</li> <li>• Is any related repair information available?</li> </ul>	Yes	Perform repair or diagnosis according to available repair information. <ul style="list-style-type: none"> <li>• If vehicle is not repaired, go to next step.</li> </ul>
		No	Go to next step.
2	<b>INSPECT DRIVE BELT CONDITION</b> <ul style="list-style-type: none"> <li>• Verify that drive belt auto tensioner indicator mark is not exceeding limit. (See 01-10A-3 DRIVE BELT INSPECTION [ZM].)</li> <li>• Is front drive belt okay?</li> </ul>	Yes	Go to next step.
		No	Replace and/or adjust drive belt, then go to Step 9.
3	<b>INSPECT PCM CONNECTOR FOR POOR CONNECTION</b> <ul style="list-style-type: none"> <li>• Turn ignition key to OFF.</li> <li>• Disconnect PCM connector.</li> <li>• Check for poor connection (damaged/pulled-out terminals, corrosion, etc.).</li> <li>• Is there malfunction?</li> </ul>	Yes	Repair terminals, then go to Step 9.
		No	Go to next step.
4	<b>INSPECT GENERATOR CONNECTOR FOR POOR CONNECTION</b> <ul style="list-style-type: none"> <li>• Disconnect generator connector.</li> <li>• Check for poor connection (damaged/pulled-out terminals, corrosion, etc.).</li> <li>• Is there malfunction?</li> </ul>	Yes	Repair or replace terminals, then go to Step 9.
		No	Go to next step.
5	<b>INSPECT GENERATOR CONTROL CIRCUIT FOR SHORT TO GROUND</b> <ul style="list-style-type: none"> <li>• Check for continuity between generator terminal D (harness-side) and body ground.</li> <li>• Is there continuity?</li> </ul>	Yes	Repair or replace harness for short to ground, then go to Step 9.
		No	Go to next step.
6	<b>INSPECT GENERATOR OUTPUT VOLTAGE MONITOR CIRCUIT FOR GROUND</b> <ul style="list-style-type: none"> <li>• Check continuity between generator terminal P (harness-side) and body ground.</li> <li>• Is there continuity?</li> </ul>	Yes	Repair or replace harness for short to ground, then go to Step 9.
		No	Go to next step.
7	<b>INSPECT GENERATOR CONTROL CIRCUIT FOR OPEN CIRCUIT</b> <ul style="list-style-type: none"> <li>• Connect breakout box with PCM disconnected.</li> <li>• Measure resistance between generator terminal D (harness-side) and breakout box terminal 53.</li> <li>• Is there continuity?</li> </ul>	Yes	Go to next step.
		No	Repair or replace harness for open circuit, then go to Step 9.
8	<b>INSPECT GENERATOR OUTPUT VOLTAGE MONITOR CIRCUIT FOR OPEN CIRCUIT</b> <ul style="list-style-type: none"> <li>• Measure resistance between generator terminal P (harness-side) and breakout box terminal 30.</li> <li>• Is there continuity?</li> </ul>	Yes	Repair or replace generator, then go to next step.
		No	Repair or replace harness for open, then go to next step.
9	<b>VERIFY TROUBLESHOOTING OF DTC P1631 COMPLETED</b> <ul style="list-style-type: none"> <li>• Make sure to reconnect all disconnected connectors.</li> <li>• Clear DTC from memory using WDS or equivalent.</li> <li>• Turn ignition switch to OFF, then start engine.</li> <li>• Is same DTC present?</li> </ul>	Yes	Replace PCM, then go to next step.
		No	No concern is detected. Go to next step.
10	<b>VERIFY AFTER REPAIR PROCEDURE</b> <ul style="list-style-type: none"> <li>• Perform "After Repair Procedure". (See 01-02A-10 AFTER REPAIR PROCEDURE [ZM].)</li> <li>• Is there any DTC present?</li> </ul>	Yes	Go to applicable DTC inspection. (See 01-02A-15 DTC TABLE [ZM].)
		No	Troubleshooting completed.

# ON-BOARD DIAGNOSTIC [ENGINE CONTROL SYSTEM (ZM)]

DTC P1632 [ZM]

A3U010201083W37

<b>DTC P1632</b>	<b>Battery voltage monitor signal circuit malfunction</b>
<b>DETECTION CONDITION</b>	<ul style="list-style-type: none"> <li>PCM monitors voltage of battery positive terminal at PCM terminal 4. If PCM detects battery positive terminal voltage <b>below 7.97 V for 5 seconds</b>, PCM determines that battery positive voltage circuit has malfunction.</li> </ul>
<b>POSSIBLE CAUSE</b>	<ul style="list-style-type: none"> <li>Open circuit in wiring between battery positive terminal and PCM terminal 4</li> <li>Poor connection of PCM connector</li> <li>PCM malfunction</li> </ul>
<p style="text-align: center;">HARNESS SIDE CONNECTOR (VIEW FROM HARNESS SIDE)</p>	

01-02A

**Diagnostic procedure**

STEP	INSPECTION		ACTION
1	<b>VERIFY RELATED REPAIR INFORMATION AVAILABILITY</b> <ul style="list-style-type: none"> <li>Check for related Service Bulletins availability.</li> <li>Is any related repair information available?</li> </ul>	Yes	Perform repair or diagnosis according to available repair information. <ul style="list-style-type: none"> <li>If vehicle is not repaired, go to next step.</li> </ul>
		No	Go to next step.
2	<b>INSPECT PCM CONNECTOR FOR POOR CONNECTION</b> <ul style="list-style-type: none"> <li>Disconnect PCM connector.</li> <li>Check for poor connection (damaged/pulled-out terminals, corrosion, etc.).</li> <li>Is there malfunction?</li> </ul>	Yes	Repair terminals, then go to Step 4.
		No	Go to next step.
3	<b>INSPECT MONITOR CIRCUIT FOR OPEN</b> <ul style="list-style-type: none"> <li>Disconnect battery cables.</li> <li>Check for continuity between Battery positive terminal and PCM terminal 4.</li> <li>Is there continuity?</li> </ul>	Yes	Go to next step.
		No	Repair or replace harness, then go to next step.
4	<b>VERIFY TROUBLESHOOTING OF DTC P1632 COMPLETED</b> <ul style="list-style-type: none"> <li>Make sure to reconnect all disconnected connectors.</li> <li>Clear DTC from memory using WDS or equivalent.</li> <li>Turn ignition key to OFF, then start engine.</li> <li>Is same DTC present?</li> </ul>	Yes	Replace PCM, then go to next step.
		No	No concern is detected. Go to next step.
5	<b>VERIFY AFTER REPAIR PROCEDURE</b> <ul style="list-style-type: none"> <li>Perform "After Repair Procedure". (See 01-02A-10 AFTER REPAIR PROCEDURE [ZM].)</li> <li>Is there any DTC present?</li> </ul>	Yes	Go to applicable DTC inspection. (See 01-02A-15 DTC TABLE [ZM].)
		No	Troubleshooting completed.

# ON-BOARD DIAGNOSTIC [ENGINE CONTROL SYSTEM (ZM)]

**DTC P1633 [ZM]**

A3U010201083W38

<b>DTC P1633</b>	<b>Battery overcharge</b>
<b>DETECTION CONDITION</b>	<ul style="list-style-type: none"> <li>PCM monitors input voltage from generator and battery positive terminal. If PCM detects generator output voltage <b>above 18.47 V</b> or battery voltage <b>above 15.94 V</b> for <b>5 seconds</b> while engine running, PCM determines that charging system has malfunction.</li> </ul>
<b>POSSIBLE CAUSE</b>	<ul style="list-style-type: none"> <li>Short to power circuit between generator connector terminal D and PCM connector terminal 53</li> <li>Generator malfunction</li> <li>PCM malfunction</li> </ul>

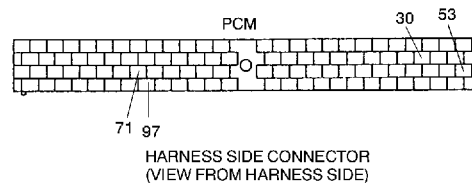
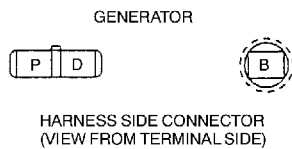
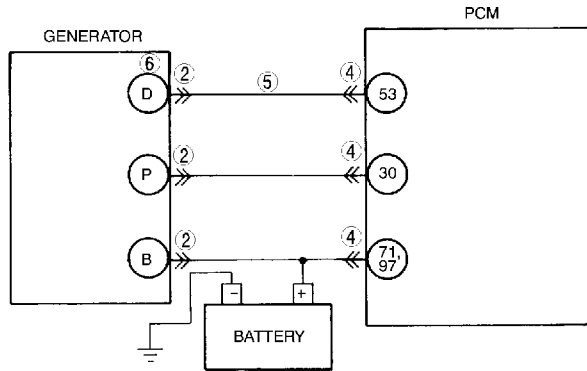

**Diagnostic procedure**

STEP	INSPECTION		ACTION
1	<b>VERIFY RELATED REPAIR INFORMATION AVAILABILITY</b> <ul style="list-style-type: none"> <li>Check for related Service Bulletins availability.</li> <li>Is any related repair information available?</li> </ul>	Yes	Perform repair or diagnosis according to available repair information. <ul style="list-style-type: none"> <li>If vehicle is not repaired, go to next step.</li> </ul>
		No	Go to next step.
2	<b>INSPECT GENERATOR CONNECTOR FOR POOR CONNECTION</b> <ul style="list-style-type: none"> <li>Turn ignition key to OFF.</li> <li>Disconnect generator connector.</li> <li>Check for poor connection (damaged/pulled-out terminals, corrosion, etc.).</li> <li>Is there malfunction?</li> </ul>	Yes	Repair or replace terminals, then go to Step 7.
		No	Go to next step.
3	<b>CLASSIFY GENERATOR MALFUNCTION OR OTHER MALFUNCTION</b> <ul style="list-style-type: none"> <li>Turn ignition key to ON (Engine OFF).</li> <li>Measure voltage between generator terminal D (harness-side) and body ground.</li> <li>Is voltage <b>B+</b>?</li> </ul>	Yes	Go to next step.
		No	Malfunction at generator. Go to Step 6.
4	<b>INSPECT PCM CONNECTOR FOR POOR CONNECTION</b> <ul style="list-style-type: none"> <li>Turn ignition key to OFF.</li> <li>Disconnect PCM connector.</li> <li>Check for poor connection (damaged/pulled-out terminals, corrosion, etc.).</li> <li>Is there malfunction?</li> </ul>	Yes	Repair or replace pins, then go to Step 7.
		No	Go to next step.
5	<b>INSPECT GENERATOR CONTROL CIRCUIT FOR SHORT TO POWER</b> <ul style="list-style-type: none"> <li>Turn ignition key to ON (Engine OFF).</li> <li>Measure voltage between generator terminal D (harness-side) and body ground.</li> <li>Is voltage <b>B+</b>?</li> </ul>	Yes	Repair or replace harness for short to power, then go to Step 7.
		No	Go to Step 7.

# ON-BOARD DIAGNOSTIC [ENGINE CONTROL SYSTEM (ZM)]

01-02A

STEP	INSPECTION		ACTION
6	<b>INSPECT GENERATOR CONTROL TERMINAL FOR SHORT TO POWER</b> <ul style="list-style-type: none"> <li>Measure resistance between generator terminal D (part-side) and body ground.</li> <li>Is voltage <b>B+</b>?</li> </ul>	Yes	Repair or replace generator, then go to Step 7.
		No	Go to next step.
7	<b>VERIFY TROUBLESHOOTING OF DTC P1633 COMPLETED</b> <ul style="list-style-type: none"> <li>Make sure to reconnect all disconnected connectors.</li> <li>Clear DTC from PCM memory using WDS or equipment.</li> <li>Turn ignition key to OFF, then start engine.</li> <li>Is same DTC present?</li> </ul>	Yes	Replace PCM, then go to next step.
		No	No concern is detected. Go to next step.
8	<b>VERIFY AFTER REPAIR PROCEDURE</b> <ul style="list-style-type: none"> <li>Perform "After Repair Procedure". (See 01-02A-10 AFTER REPAIR PROCEDURE [ZM].)</li> <li>Is there any DTC present?</li> </ul>	Yes	Go to applicable DTC inspection. (See 01-02A-15 DTC TABLE [ZM].)
		No	Troubleshooting completed.

## DTC P1634 [ZM]

A3U010201083W39

DTC P1634	Generator terminal B circuit open
<b>DETECTION CONDITION</b>	<ul style="list-style-type: none"> <li>PCM monitors input voltage from generator and battery positive terminal. If PCM detects generator output voltage <b>above 16.97 V</b> and battery voltage <b>below 10.94 V</b> for <b>5 seconds</b> while engine running, PCM determines that charging system has malfunction.</li> </ul>
<b>POSSIBLE CAUSE</b>	<ul style="list-style-type: none"> <li>Open circuit between generator terminal B and battery positive terminal</li> <li>Battery malfunction</li> <li>PCM malfunction</li> </ul>
<p style="text-align: center;"> <span style="display: inline-block; margin-right: 100px;"> <b>GENERATOR</b>                        HARNESS SIDE CONNECTOR                      (VIEW FROM TERMINAL SIDE)                 </span> <span> <b>PCM</b>                        HARNESS SIDE CONNECTOR                      (VIEW FROM HARNESS SIDE)                 </span> </p>	

## Diagnostic procedure

STEP	INSPECTION		ACTION
1	<b>VERIFY RELATED REPAIR INFORMATION AVAILABILITY</b> <ul style="list-style-type: none"> <li>Check for related Service Bulletins availability.</li> <li>Is any related repair information available?</li> </ul>	Yes	Perform repair or diagnosis according to available repair information. <ul style="list-style-type: none"> <li>If vehicle is not repaired, go to next step.</li> </ul>
		No	Go to next step.
2	<b>INSPECT BATTERY</b> <ul style="list-style-type: none"> <li>Turn ignition key to OFF.</li> <li>Inspect battery. (See 01-17-1 BATTERY INSPECTION.)</li> <li>Is battery okay?</li> </ul>	Yes	Replace battery, then go to Step 6.
		No	Go to next step.

## ON-BOARD DIAGNOSTIC [ENGINE CONTROL SYSTEM (ZM)]

STEP	INSPECTION	ACTION	
3	<b>INSPECT GENERATOR TERMINAL FOR POOR INSTALLATION</b> <ul style="list-style-type: none"> <li>• Turn ignition key to OFF.</li> <li>• Check for looseness of generator terminal B installation nut.</li> <li>• Is nut loose?</li> </ul>	Yes	Tighten generator terminal B installation nut, then go to Step 6.
		No	Go to next step.
4	<b>INSPECT BATTERY POSITIVE TERMINAL FOR POOR INSTALLATION</b> <ul style="list-style-type: none"> <li>• Check for looseness of battery positive terminal.</li> <li>• Is terminal loose?</li> </ul>	Yes	Connect battery positive terminal correctly, then go to Step 6.
		No	Go to next step.
5	<b>INSPECT BATTERY CHARGING CIRCUIT</b> <ul style="list-style-type: none"> <li>• Start engine.</li> <li>• Disconnect battery positive terminal.</li> <li>• Does engine stall?</li> </ul>	Yes	Repair or replace harness between generator terminal B and battery positive terminal, then go to next step.
		No	Go to next step.
6	<b>VERIFY TROUBLESHOOTING OF DTC P1634 COMPLETED</b> <ul style="list-style-type: none"> <li>• Make sure to reconnect all disconnected connectors.</li> <li>• Clear DTC from PCM memory using WDS or equivalent.</li> <li>• Turn ignition key to OFF, then start engine.</li> <li>• Is same DTC present?</li> </ul>	Yes	Replace PCM, then go to next step.
		No	No concern is detected. Go to next step.
7	<b>VERIFY AFTER REPAIR PROCEDURE</b> <ul style="list-style-type: none"> <li>• Perform "After Repair Procedure". (See 01-02A-10 AFTER REPAIR PROCEDURE [ZM].)</li> <li>• Is there any DTC present?</li> </ul>	Yes	Go to applicable DTC inspection. (See 01-02A-15 DTC TABLE [ZM].)
		No	Troubleshooting completed.



# 01-02B ON-BOARD DIAGNOSTIC [ENGINE CONTROL SYSTEM (FS)]

CONTROL SYSTEM WIRING DIAGRAM [FS] .....	01-02B-2	DTC P0118 [FS] .....	01-02B-42
CONTROL SYSTEM DEVICE AND CONTROL RELATIONSHIP CHART [FS] .....	01-02B-4	DTC P0121 [FS] .....	01-02B-43
Engine Control System .....	01-02B-4	DTC P0122 [FS] .....	01-02B-46
Monitoring System .....	01-02B-5	DTC P0123 [FS] .....	01-02B-47
FOREWORD [FS] .....	01-02B-6	DTC P0125 [FS] .....	01-02B-49
OBD-II PENDING TROUBLE CODES [FS] .....	01-02B-6	DTC P0126, P0128 [FS] .....	01-02B-50
OBD-II FREEZE FRAME DATA [FS] ...	01-02B-6	DTC P0131 [FS] .....	01-02B-52
OBD-II ON-BOARD SYSTEM READINESS TEST [FS] .....	01-02B-6	DTC P0132 [FS] .....	01-02B-55
OBD-II DIAGNOSTIC MONITORING TEST RESULTS [FS] .....	01-02B-6	DTC P0133 [FS] .....	01-02B-57
OBD-II READ/CLEAR DIAGNOSTIC TEST RESULTS [FS] .....	01-02B-7	DTC P0134 [FS] .....	01-02B-61
OBD-II PARAMETER IDENTIFICATION (PID) ACCESS [FS] .....	01-02B-7	DTC P0138 [FS] .....	01-02B-63
ON-BOARD DIAGNOSTIC TEST [FS] ..	01-02B-7	DTC P0140 [FS] .....	01-02B-64
DTCs Retrieving Procedure .....	01-02B-7	DTC P0171 [FS] .....	01-02B-67
Pending Trouble Code Access Procedure .....	01-02B-7	DTC P0172 [FS] .....	01-02B-70
Freeze Frame PID Data Access Procedure .....	01-02B-8	DTC P0300 [FS] .....	01-02B-71
On-Board System Readiness Tests Access Procedure .....	01-02B-8	DTC P0301, P0302, P0303, P0304 [FS]	01-02B-75
PID/DATA Monitor and Record Procedure .....	01-02B-8	DTC P0325 [FS] .....	01-02B-77
Diagnostic Monitoring Test Results Access Procedure .....	01-02B-9	DTC P0335 [FS] .....	01-02B-79
AFTER REPAIR PROCEDURE [FS] ...	01-02B-9	DTC P0340 [FS] .....	01-02B-80
OBD-II DRIVE MODE [FS] .....	01-02B-10	DTC P0401 [FS] .....	01-02B-82
Mode 1 (PCM adaptive memory procedure drive mode) .....	01-02B-10	DTC P0402 [FS] .....	01-02B-83
Mode 2 (EGR system repair verification drive mode) .....	01-02B-11	DTC P0421 [FS] .....	01-02B-84
Mode 3 (HO2S heater, HO2S, and TWC repair verification drive mode) .....	01-02B-11	DTC P0442 [FS] .....	01-02B-86
Mode 4 (EVAP system repair verification drive mode) .....	01-02B-12	DTC P0443 [FS] .....	01-02B-89
Mode 5 (EVAP system very small leak repair verification drive mode) .....	01-02B-13	DTC P0451 [FS] .....	01-02B-90
DIAGNOSTIC MONITORING TEST RESULTS [FS] .....	01-02B-14	DTC P0452 [FS] .....	01-02B-93
DTC TABLE [FS] .....	01-02B-15	DTC P0453 [FS] .....	01-02B-95
DTC P0031 [FS] .....	01-02B-19	DTC P0455 [FS] .....	01-02B-97
DTC P0032 [FS] .....	01-02B-20	DTC P0456 [FS] .....	01-02B-102
DTC P0037 [FS] .....	01-02B-22	DTC P0461 [FS] .....	01-02B-104
DTC P0038 [FS] .....	01-02B-23	DTC P0462 [FS] .....	01-02B-105
DTC P0101 [FS] .....	01-02B-25	DTC P0463 [FS] .....	01-02B-107
DTC P0102 [FS] .....	01-02B-27	DTC P0464 [FS] .....	01-02B-108
DTC P0103 [FS] .....	01-02B-29	DTC P0480 [FS] .....	01-02B-109
DTC P0106 [FS] .....	01-02B-30	DTC P0500 [FS] .....	01-02B-111
DTC P0107 [FS] .....	01-02B-31	DTC P0505 [FS] .....	01-02B-113
DTC P0108 [FS] .....	01-02B-34	DTC P0506 [FS] .....	01-02B-115
DTC P0111 [FS] .....	01-02B-35	DTC P0507 [FS] .....	01-02B-117
DTC P0112 [FS] .....	01-02B-36	DTC P0550 [FS] .....	01-02B-118
DTC P0113 [FS] .....	01-02B-38	DTC P0660 [FS] .....	01-02B-119
DTC P0117 [FS] .....	01-02B-40	DTC P0703 [FS] .....	01-02B-122
		DTC P0704 [FS] .....	01-02B-123
		DTC P0705 [FS] .....	01-02B-125
		DTC P1250 [FS] .....	01-02B-127
		DTC P1449 [FS] .....	01-02B-129
		DTC P1450 [FS] .....	01-02B-131
		DTC P1487 [FS] .....	01-02B-133
		DTC P1496 [FS] .....	01-02B-135
		DTC P1497 [FS] .....	01-02B-137
		DTC P1498 [FS] .....	01-02B-139
		DTC P1499 [FS] .....	01-02B-141
		DTC P1512 [FS] .....	01-02B-143
		DTC P1562 [FS] .....	01-02B-144
		DTC P1569 [FS] .....	01-02B-146
		DTC P1570 [FS] .....	01-02B-148
		DTC P1631 [FS] .....	01-02B-150
		DTC P1632 [FS] .....	01-02B-152
		DTC P1633 [FS] .....	01-02B-153
		DTC P1634 [FS] .....	01-02B-154

# ON-BOARD DIAGNOSTIC [ENGINE CONTROL SYSTEM (FS)]

## CONTROL SYSTEM WIRING DIAGRAM [FS]

A3U010218881W01

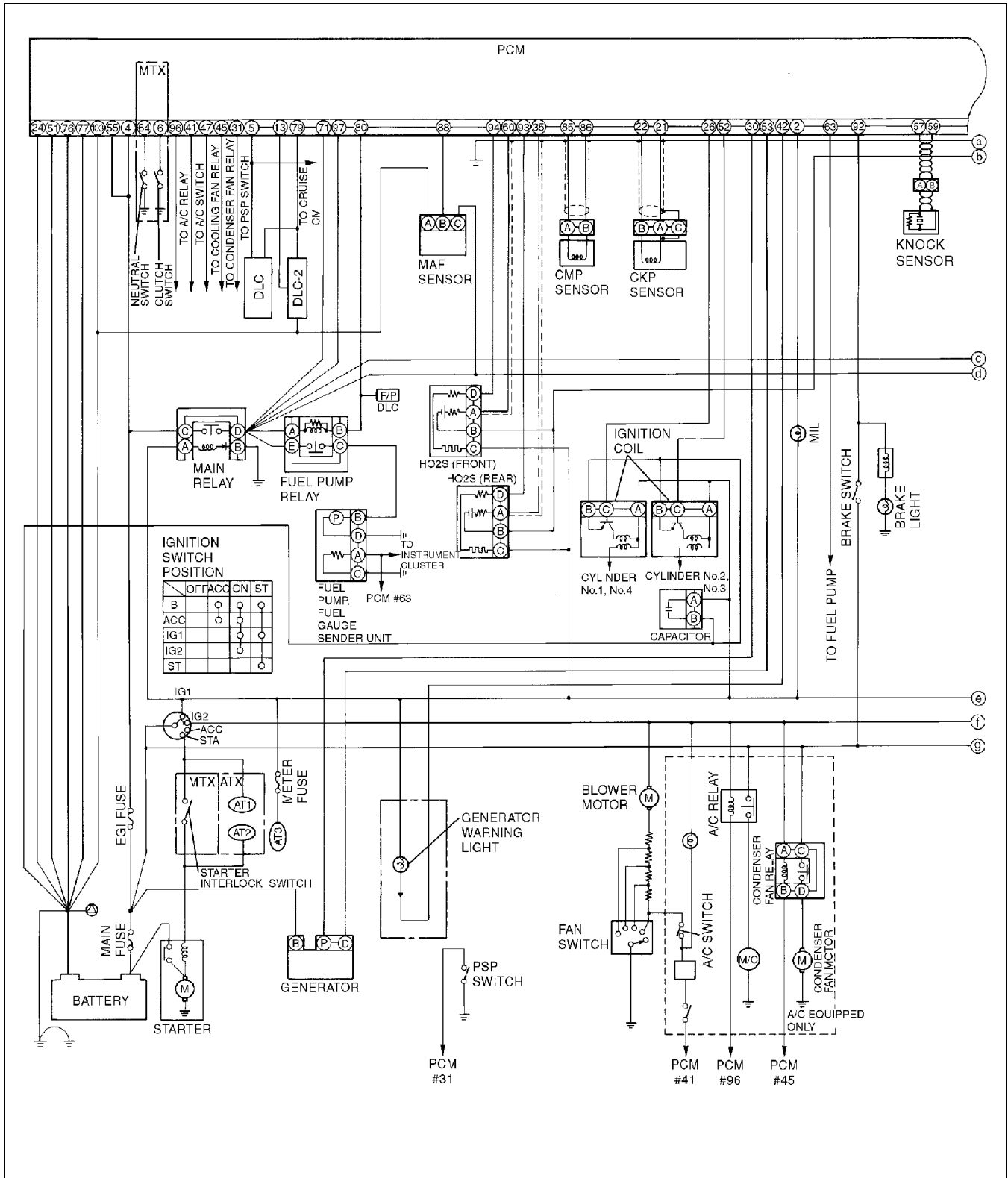

A3U0140W001

# ON-BOARD DIAGNOSTIC [ENGINE CONTROL SYSTEM (FS)]

01-02B

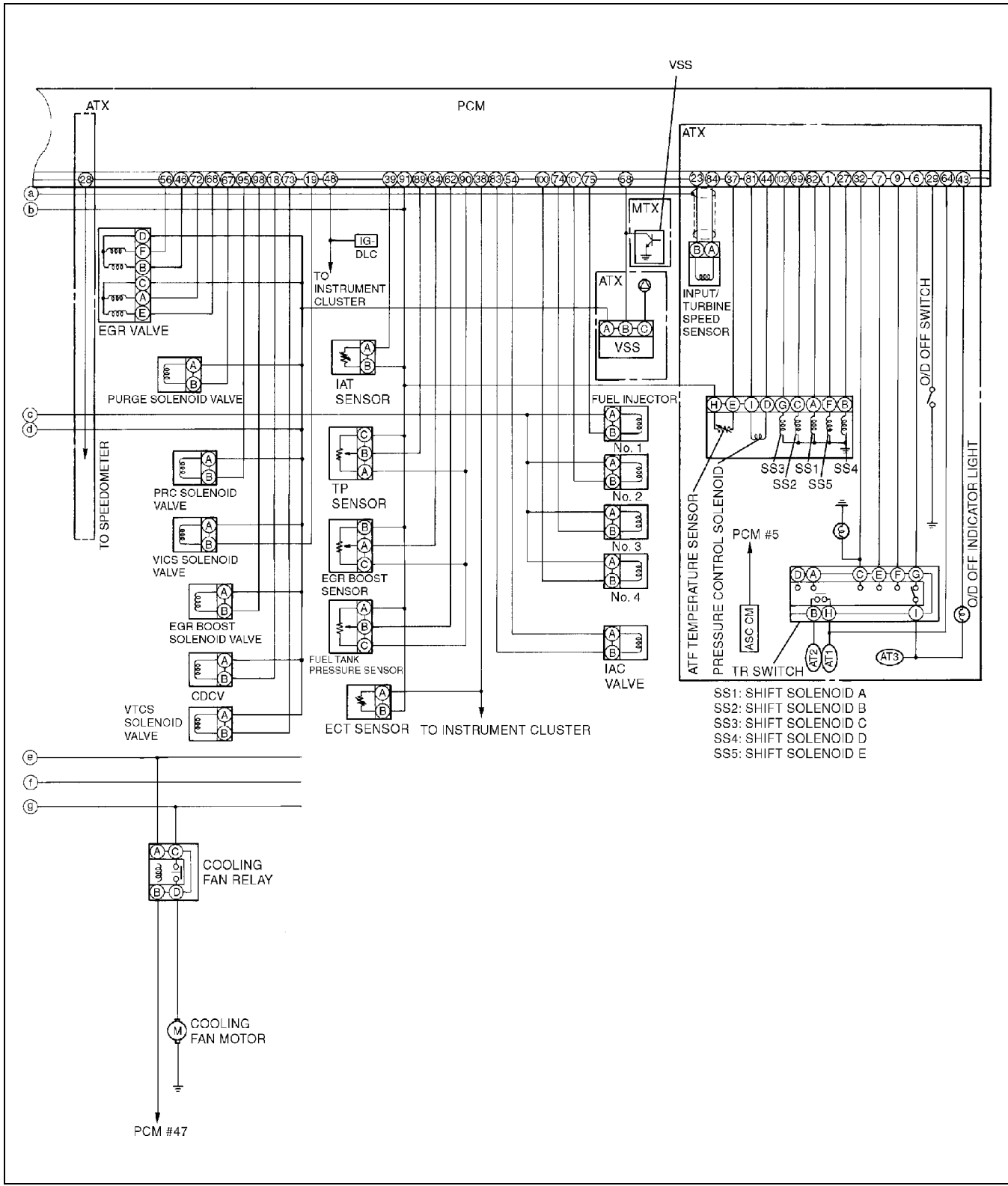

Z3U0140W104

# ON-BOARD DIAGNOSTIC [ENGINE CONTROL SYSTEM (FS)]

## CONTROL SYSTEM DEVICE AND CONTROL RELATIONSHIP CHART [FS]

A3U010218881W02

### Engine Control System

Component	Idle air control (IAC)	Fuel injection control	Pressure regulator control (PRC)	Electronic spark advance (ESA) control	Fuel pump control	HO2S heater (front) control	HO2S heater (rear) control	Electric fan control	Purge control	EGR control	VICS	VTCS	A/C cut-out control	Generator control
<b>Input</b>														
Brake switch		x		x										
Refrigerant pressure switch, A/C switch, blower fan switch and A/C amplifier	x	x		x				x					x	
PSP switch	x	x		x									x	
DLC in engine compartment (TEN)	x	x	x	x				x						
Neutral switch (MTX)	x	x	x	x										
Clutch switch (MTX)	x	x	x	x										
TR switch (ATX)	x	x	x	x										
CKP sensor	x	x	x	x	x	x	x	x	x	x	x	x	x	x
CMP sensor	x	x		x										
VSS	x	x		x						x				x
MAF sensor	x	x		x		x	x		x	x				
ECT sensor	x	x	x	x		x	x	x	x	x		x	x	x
IAT sensor	x	x	x	x		x			x	x				x
TP sensor	x	x	x	x		x		x	x	x		x	x	x
EGR boost sensor	x	x							x				x	
Battery positive voltage		x		x		x			x					x
Generator	x			x										x
HO2S (front)		x							x					
HO2S (rear)														
<b>Output</b>														
IAC valve	x													
A/C relay													x	
Cooling fan relay								x						
Condenser fan relay								x						
Fuel pump relay					x									
PRC solenoid valve			x											
Purge solenoid valve									x					
VICS solenoid valve											x			
VTCS solenoid valve												x		
EGR valve										x				
HO2S heater						x	x							
Ignition coils				x										
Fuel injectors		x												
Generator (field coil)														x
Generator warning light														x

# ON-BOARD DIAGNOSTIC [ENGINE CONTROL SYSTEM (FS)]

## Monitoring System

× : Applied

Component	Catalyst monitor	Misfire monitor	Evaporative system monitor	Fuel system monitor	Oxygen sensor monitor	Oxygen sensor heater monitor	EGR system monitor
<b>Input</b>							
Brake switch							
Refrigerant pressure switch, A/C switch, blower fan switch and A/C amplifier		×		×			×
PSP switch		×		×			×
CKP sensor	×	×	×	×	×	×	×
CMP sensor	×	×	×	×	×	×	×
VSS	×	×	×	×	×		×
MAF sensor	×	×	×	×	×	×	×
ECT sensor	×	×	×	×	×	×	×
IAT sensor	×	×	×	×	×		×
TP sensor	×	×	×	×	×		×
EGR boost sensor							×
Fuel level sensor			×				
Fuel gauge sender unit			×				
Rear HO2S	×				×	×	
Front HO2S	×			×	×	×	
<b>Output</b>							
DLC-2 in passenger compartment (Terminal KLN)	×	×	×	×	×	×	×
MIL	×	×	×	×	×	×	×
Purge solenoid valve			×	×	×		
EGR valve							×
EGR boost sensor solenoid valve							×
Canister drain cut valve			×				
Fuel injectors				×			

01-02B

Y3U102WBC

# ON-BOARD DIAGNOSTIC [ENGINE CONTROL SYSTEM (FS)]

## FOREWORD [FS]

A3U010218881W03

- When the customer reports a vehicle malfunction, check the malfunction indicator light (MIL) indication and diagnostic trouble code (DTC), then diagnose the malfunction according to following flowchart.
  - If the DTC exists, diagnose the applicable DTC inspection. (See 01–02B–15 DTC TABLE [FS].)
  - If the DTC does not exist and the MIL does not illuminate or flash, diagnose the applicable symptom troubleshooting. (See 01–03B–7 SYMPTOM DIAGNOSTIC INDEX [FS].)

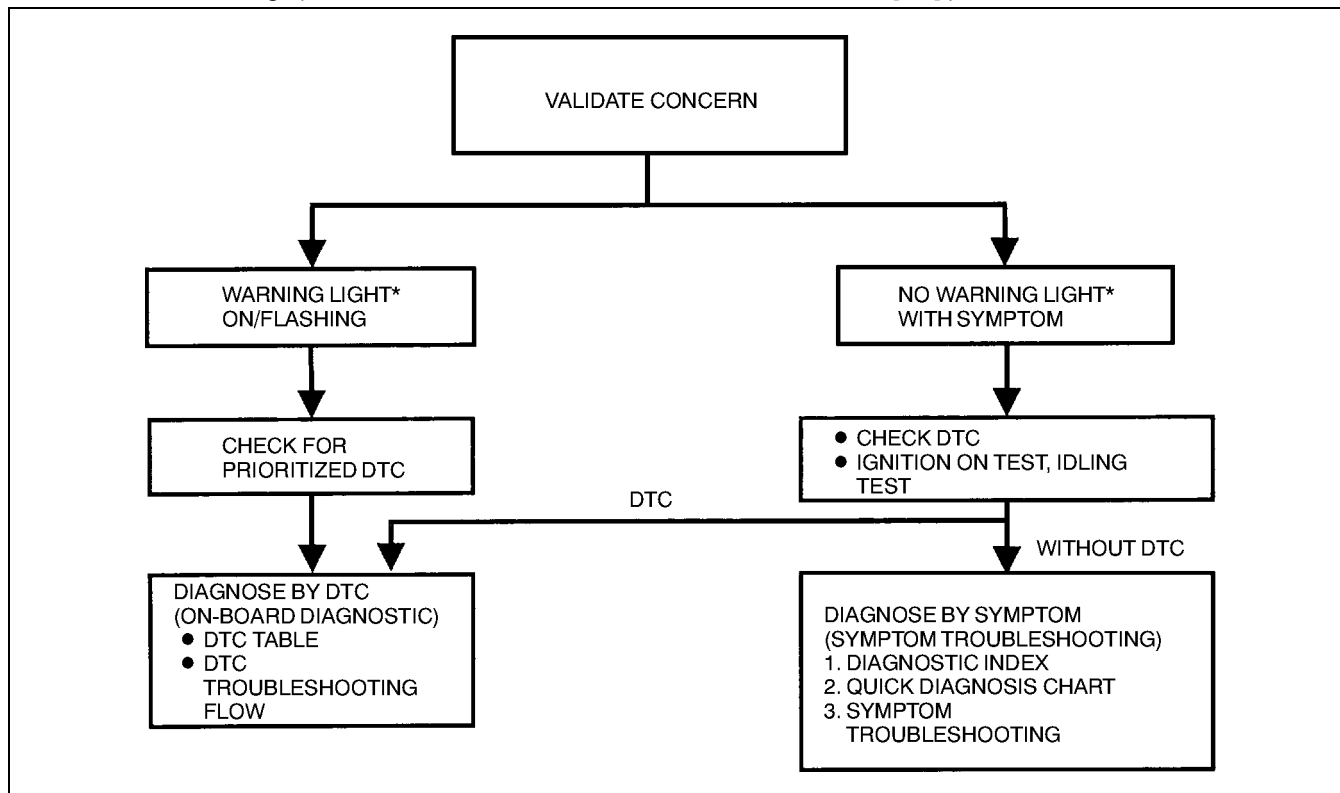

YMU102WBX

\* : Malfunction Indicator Light (MIL), Generator Warning Light, Security Light

## OBD-II PENDING TROUBLE CODES [FS]

A3U010218881W04

- The following functions are generic functions.
- These appear when a problem is detected in a monitored system. The MIL is illuminated when a problem is detected in two consecutive drive cycles. The code for a failed system is stored in the PCM memory in the first drive cycle. This code is called the pending code. If the problem is not found in the second drive cycle, the PCM judges that the system returned to normal or the problem was mistakenly detected, and deletes the pending code. If the problem is found in the second drive cycle too, the PCM judges that the system has failed, deletes the pending code, illuminates the MIL and store the DTC.

## OBD-II FREEZE FRAME DATA [FS]

A3U010218881W05

- This is the technical data which indicates the engine's condition at the time of the first malfunction. This data will remain in the memory even if another emission-related DTC is stored, with the exception of the Misfire or Fuel System DTCs. Once freeze frame data for the Misfire or Fuel System DTC is stored, it will overwrite any previous data and the freeze frame will not be overwritten again.

## OBD-II ON-BOARD SYSTEM READINESS TEST [FS]

A3U010218881W06

- This shows OBD-II systems operating status. If any monitor function is incomplete, WDS or equivalent will identify which monitor function has not been completed. Misfires, Fuel System and Comprehensive Components (CCM) are continuous monitoring-type functions. The catalyst, EGR system, evaporation system and oxygen sensor will be monitored under drive cycles. The OBD-II diagnostic system is initialized by performing the DTC cancellation procedure or disconnecting the negative battery cable.

## OBD-II DIAGNOSTIC MONITORING TEST RESULTS [FS]

A3U010218881W07

- These results from the intermittent monitor system's technical data, which are used to determine whether the system is normal or not. They also display the system's thresholds and diagnostic results. The intermittent monitor system monitors the oxygen sensor, evaporative purge system, catalyst and the EGR system.

# ON-BOARD DIAGNOSTIC [ENGINE CONTROL SYSTEM (FS)]

## OBD-II READ/CLEAR DIAGNOSTIC TEST RESULTS [FS]

A3U010218881W08

- The following are generic functions.
- This retrieves all stored DTCs in the PCM and clears the DTC, Freeze Frame Data, On-Board Readiness Test Results, Diagnostic Monitoring Test Results and Pending Trouble Codes.

## OBD-II PARAMETER IDENTIFICATION (PID) ACCESS [FS]

A3U010218881W09

- The PID mode allows access to certain data values, analog and digital inputs and outputs, calculated values and system status information. Since PID values for output devices are PCM internal data values, inspect each device to identify which output devices are malfunctioning.

01-02B

## ON-BOARD DIAGNOSTIC TEST [FS]

A3U010218881W10

### DTCs Retrieving Procedure

1. Perform the necessary vehicle preparation and visual inspection.
2. Connect WDS or equivalent to the vehicle DLC-2 16-pin connector located on the left side of the steering column.
3. Retrieve DTC using WDS or equivalent.

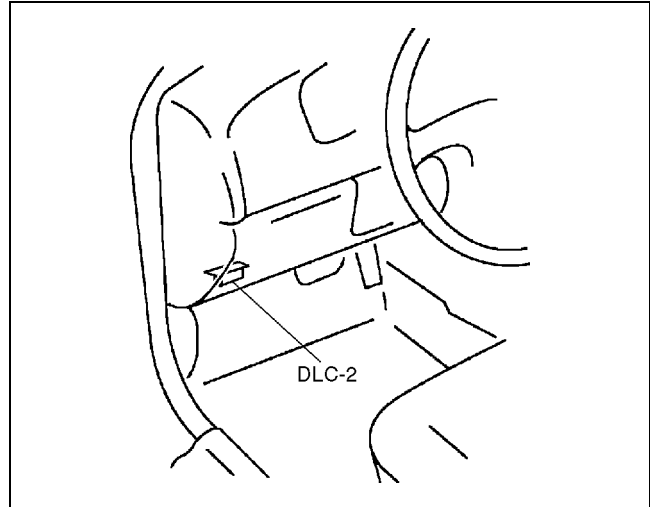

Z3U0102W001

### Pending Trouble Code Access Procedure

1. Perform the necessary vehicle preparation and visual inspection.
2. Connect WDS or equivalent to the vehicle DLC-2 16-pin connector located on the left side of the steering column.
3. Retrieve pending trouble code using WDS or equivalent.

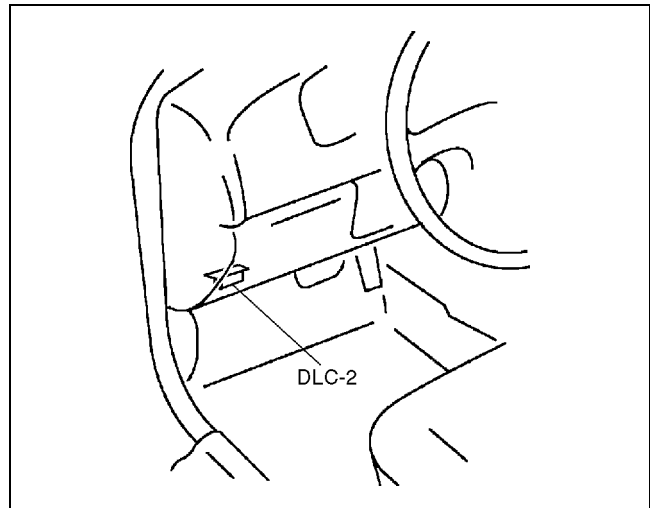

Z3U0102W001

## ON-BOARD DIAGNOSTIC [ENGINE CONTROL SYSTEM (FS)]

### Freeze Frame PID Data Access Procedure

1. Perform the necessary vehicle preparation and visual inspection.
2. Connect WDS or equivalent to the vehicle DLC-2 16-pin connector located on the left side of the steering column.
3. Retrieve FREEZE FRAME PID DATA using WDS or equivalent.

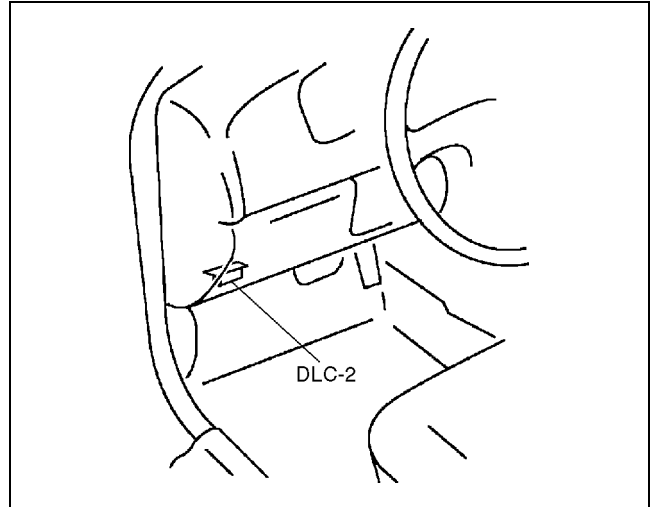

Z3U0102W001

### On-Board System Readiness Tests Access Procedure

1. Perform the necessary vehicle preparation and visual inspection.
2. Connect WDS or equivalent to the vehicle DLC-2 16-pin connector located on the left side of the steering column.
3. Monitor the OBD-II system operating status using WDS or equivalent.

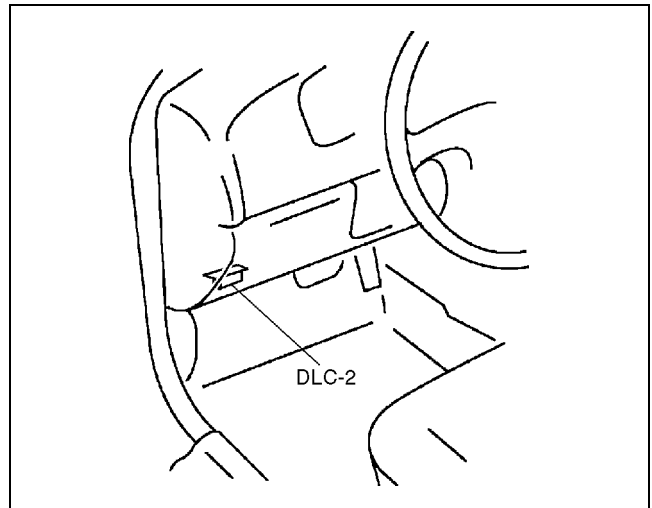

Z3U0102W001

### PID/DATA Monitor and Record Procedure

1. Perform the necessary vehicle preparation and visual inspection.
2. Connect WDS or equivalent to the vehicle DLC-2 16-pin connector located on the left side of the steering column.
3. Access and monitor PIDs using WDS or equivalent.

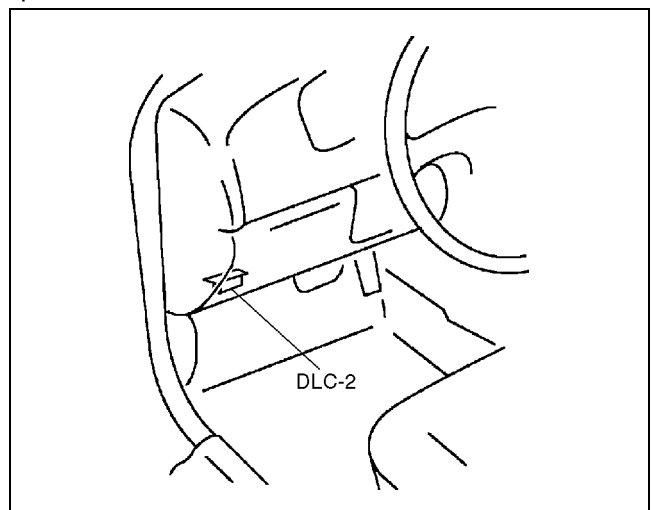

Z3U0102W001



## ON-BOARD DIAGNOSTIC [ENGINE CONTROL SYSTEM (FS)]

### Diagnostic Monitoring Test Results Access Procedure

1. Perform the necessary vehicle preparation and visual inspection.
2. Connect WDS or equivalent to the vehicle DLC-2 16-pin connector located on the left side of the steering column.
3. Access the DIAGNOSTIC MONITORING TEST RESULTS and read the test results using WDS or equivalent.

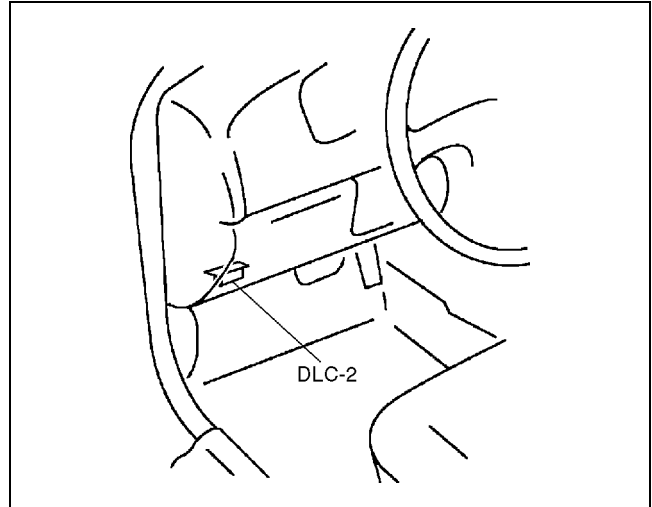

Z3U0102W001

01-02B

### AFTER REPAIR PROCEDURE [FS]

1. Connect WDS or equivalent to the vehicle DLC-2 16-pin connector located on the left side of the steering column.
2. Cycle the ignition key from OFF to ON.
3. Record DTC if retrieved.
4. Erase all diagnostic data by using WDS or equivalent.

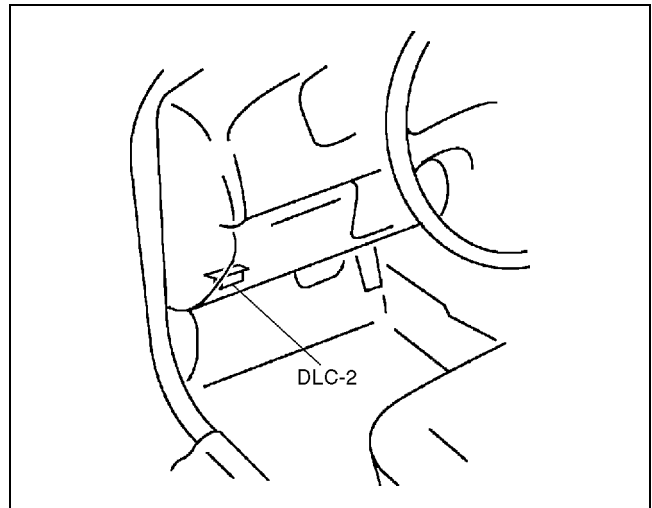

A3U010218881W11

Z3U0102W001

# ON-BOARD DIAGNOSTIC [ENGINE CONTROL SYSTEM (FS)]

A3U010218881W12

## OBD-II DRIVE MODE [FS]

- Performing the Drive Mode inspects the OBD-II system for proper operation and must be performed to ensure that no additional DTCs are present.
- During Drive Mode, the following systems are inspected:
  - EGR system
  - Oxygen sensor (HO2S)
  - Oxygen sensor heater
  - Catalytic converter (TWC)
  - Fuel, misfire and evaporative (EVAP) system

### Caution

- While performing the Drive Mode, always operate the vehicle in a safe and lawful manner.
- When the WDS or equivalent is used to observe monitor system status while driving, be sure to have another technician with you, or record the data in the WDS or equivalent using the PID/DATA MONITOR AND RECORD function and inspect later.

### Note

- Vehicle speed and engine speed detected by the PCM may differ from that indicated by the speedometer and tachometer. Use the WDS or equivalent to monitor vehicle speed.
- If the OBD-II system inspection is not completed during the Drive Mode, the following causes are considered:
  1. The OBD-II system detects the malfunction.
  2. The Drive Mode procedure is not completed correctly.
- Disconnecting the battery will reset the memory. Do not disconnect the battery during and after Drive Mode.

### Mode 1 (PCM adaptive memory procedure drive mode)

1. Start the engine and warm up completely.
2. Verify the following conditions and correct if necessary.
  - All accessory loads (A/C, headlights, blower fan, rear window defroster) are off.
  - Initial ignition timing and idle speed are within specification.
  - TEN and GND of DLC are not connected.
3. Perform no load racing at the engine speed shown in the graph, then idle the engine for **more than 20 seconds** after the cooling fan stopped. If possible, monitor RPM PID for engine speed and cooling fan status during this procedure.

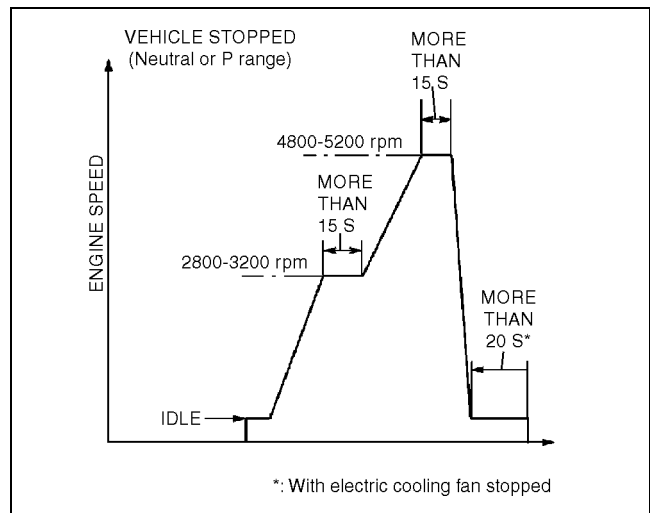

Z3U0102W002

## ON-BOARD DIAGNOSTIC [ENGINE CONTROL SYSTEM (FS)]

### Mode 2 (EGR system repair verification drive mode)

1. Perform Mode 1 first.
2. Verify all accessory loads (A/C, headlights, blower fan, rear window defroster) are off.
3. Drive the vehicle as shown in the graph.
4. Stop vehicle and access to ON BOARD SYSTEM READINESS menu of GENERIC OBD II FUNCTION to inspect the Drive Mode completion status. If completed, RFC changes from NO to YES.
5. If not completed, turn the ignition key off then go back to Step 3.
6. Access to DIAGNOSTIC MONITORING TEST RESULTS menu of GENERIC OBD II FUNCTIONS to inspect the monitor results. If MEAS are not within specification, repair has not completed.
7. Verify no DTCs are available.

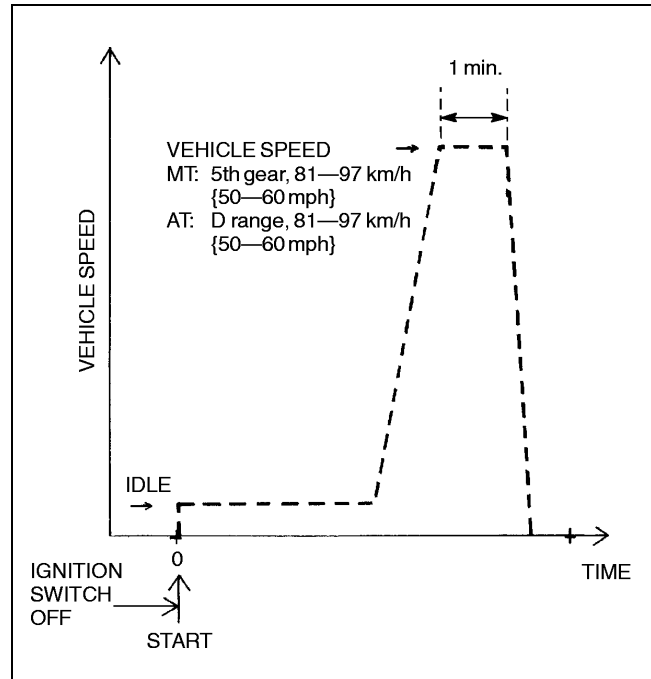

X3U101WBL

01-02B

### Mode 3 (HO2S heater, HO2S, and TWC repair verification drive mode)

1. Perform Mode 1 first.
2. Verify all accessory loads (A/C, headlights, blower fan, rear window defroster) are off.
3. Drive the vehicle as shown in the graph. Driving condition before the constant speed driving is not specified.
4. Stop vehicle and access to ON BOARD SYSTEM READINESS menu of GENERIC OBD II FUNCTION to inspect the Drive Mode completion status. If completed, RFC changes from NO to YES.
5. If not completed, turn the ignition key off then go back to Step 3.
6. Access to DIAGNOSTIC MONITORING TEST RESULTS menu of GENERIC OBD II FUNCTIONS to inspect the monitor results. If MEAS are not within specification, repair has not completed.
7. Verify no DTCs are available.

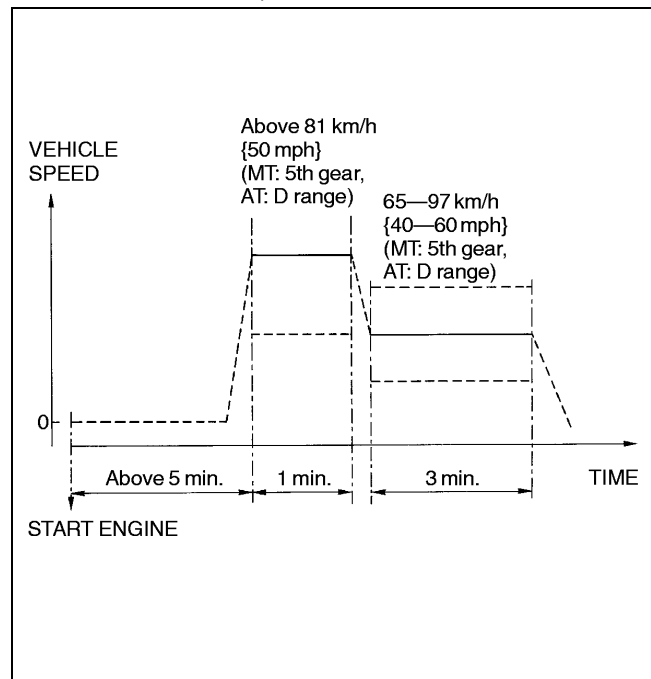

X3U101WBM

# ON-BOARD DIAGNOSTIC [ENGINE CONTROL SYSTEM (FS)]

## Mode 4 (EVAP system repair verification drive mode)

### Note

- If Mode 4 can not be performed (you can not drive the vehicle under Mode 4 condition), perform evaporative system test procedure as an alternative. (See 01-03B-54 ENGINE CONTROL SYSTEM OPERATION INSPECTION [FS].)
- Mode 4 can be performed regardless of RFC FLAG condition.

1. Verify that the following conditions are met. All conditions must be within specifications before engine started to initiate the evaporative system test.

- Barometric pressure: **69.7 kPa {523 mmHg, 20.5 inHg} or higher**
- Intake air temperature: **-10—60 °C {14—131 °F}**
- Fuel tank level: **1.3—3.75 V**
- Engine coolant temperature: **-10 °C—X °C {14 °F—X °F}** (X, the Engine coolant temperature upper limit, is determined according to the barometric pressure as shown the graph below.)

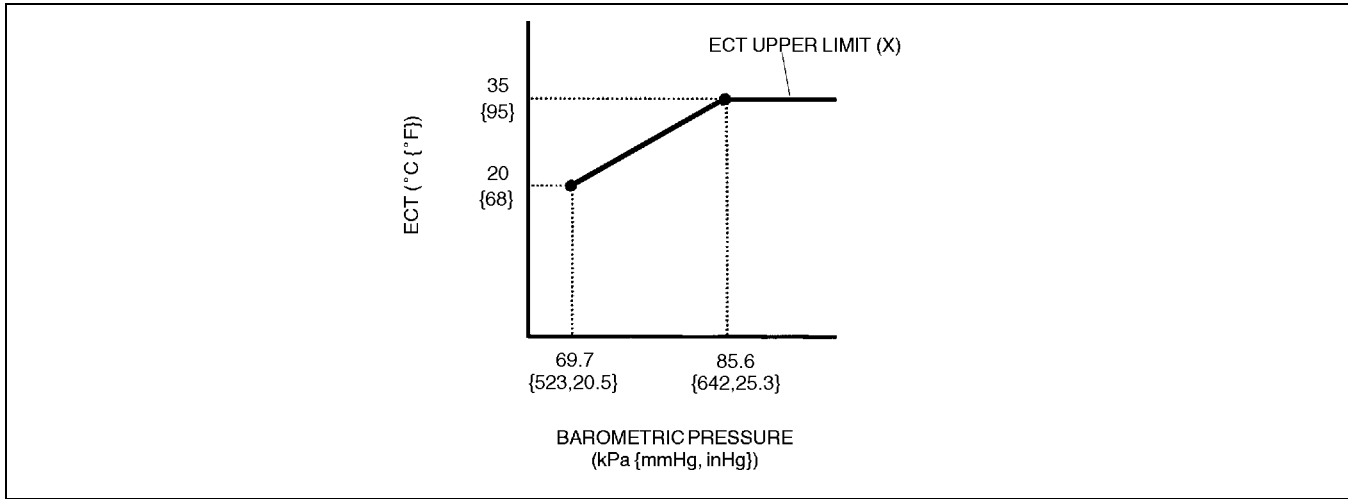

A3U0102W001

2. Verify all accessory loads (A/C, headlights, blower fan, rear window defroster) are off.
3. Start the engine and race it at **3,500 rpm** to warm up completely.
4. Drive the vehicle as shown in the graph.

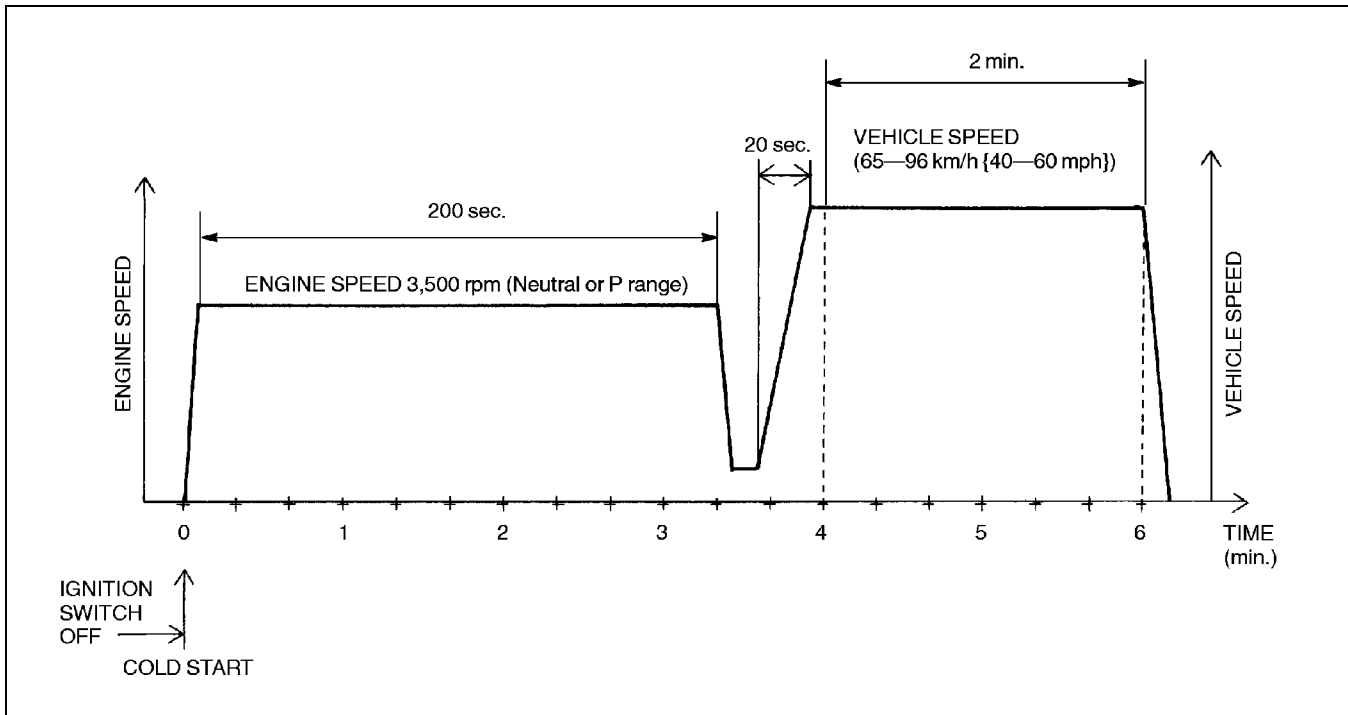

X3U101WBN

5. Stop vehicle and access to ON BOARD SYSTEM READINESS menu of GENERIC OBD II FUNCTION to inspect the Drive Mode completion status. If completed, RFC changes from NO to YES.
6. If not completed, turn the ignition key off then go back to Step 1.

## ON-BOARD DIAGNOSTIC [ENGINE CONTROL SYSTEM (FS)]

7. Access to DIAGNOSTIC MONITORING TEST RESULTS menu of GENERIC OBD II FUNCTION to inspect the monitor results. If MEAS are not within specification, repair has not completed.
8. Verify no DTCs are available.

### Mode 5 (EVAP system very small leak repair verification drive mode)

#### Note

- If Mode 5 can not be performed (you can not drive the vehicle under Mode 5 condition), perform evaporative system test procedure as an alternative. (See 01-03B-54 ENGINE CONTROL SYSTEM OPERATION INSPECTION [FS].)
- Mode 5 can be performed regardless of RFC FLAG condition.

1. Verify that the following conditions are met. All conditions must be within specifications before engine started to initiate the evaporative system test.
  - Barometric pressure: **69.7 kPa {523 mmHg, 20.5 inHg} or higher**
  - Intake air temperature: **-10—60 °C {14—131 °F}**
  - Fuel tank level: **1.3—3.75 V**
  - Engine coolant temperature: **-10 °C—X °C {14 °F—X °F}** (X, the Engine coolant temperature upper limit, is determined according to the barometric pressure as shown the graph below.)

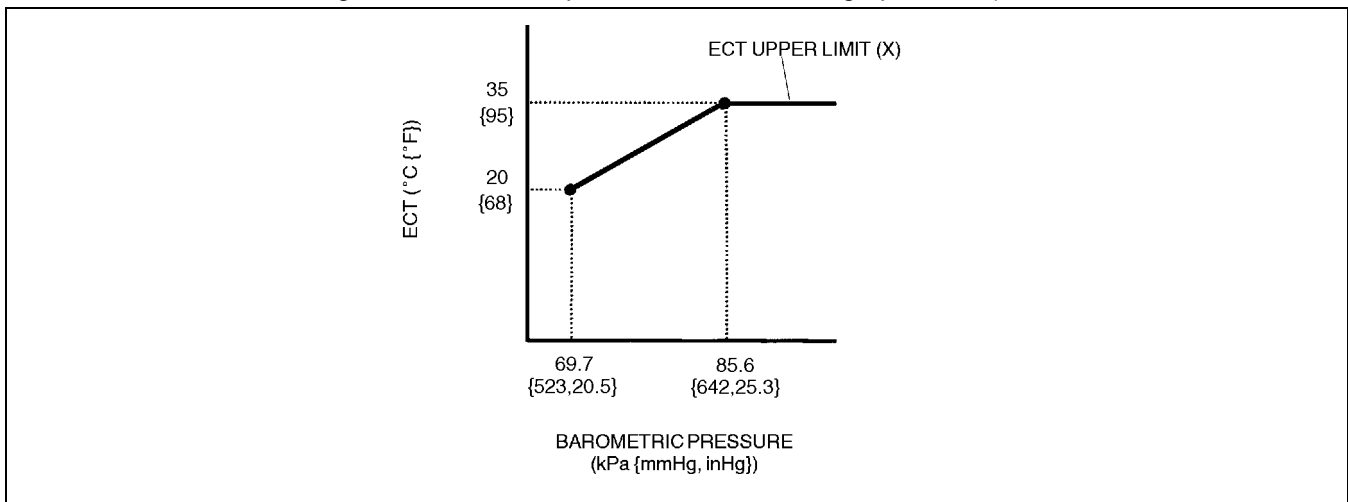

A3U0102W001

2. Verify all accessory loads (A/C, headlights, blower fan, rear window defroster) are off.
3. Start the engine and race it at **3,500 rpm** to warm up completely, then idle the engine for **120 seconds**.

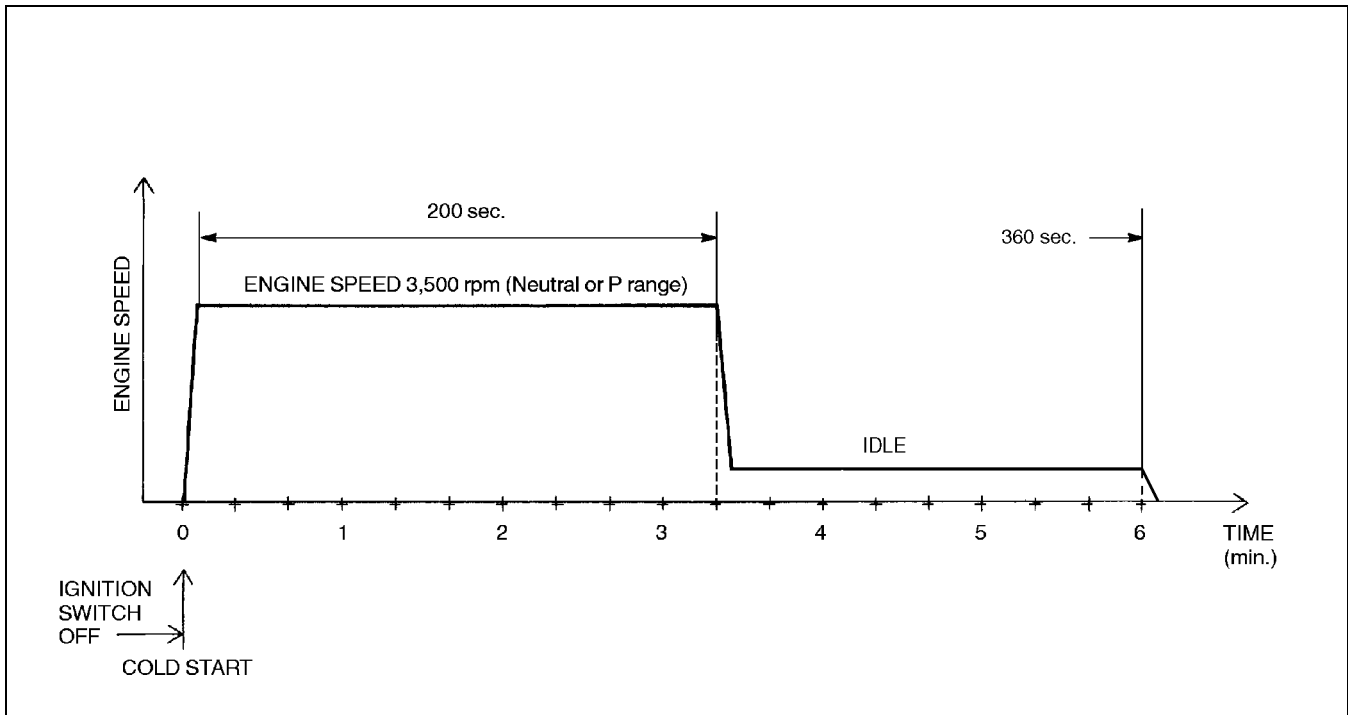

A3U0102W002

## ON-BOARD DIAGNOSTIC [ENGINE CONTROL SYSTEM (FS)]

4. Stop vehicle and access to ON BOARD SYSTEM READINESS menu of GENERIC OBD II FUNCTION to inspect the Drive Mode completion status. If completed, RFC changes from NO to YES.
5. If not completed, turn the ignition key off then go back to Step 1.
6. Access to DIAGNOSTIC MONITORING TEST RESULTS menu of GENERIC OBD II FUNCTION to inspect the monitor results. If MEAS are not within specification, repair has not completed.
7. Verify no DTCs are available.

### DIAGNOSTIC MONITORING TEST RESULTS [FS]

A3U010218881W13

- The purpose of this test mode is to confirm the result of OBD-II monitor diagnostic test results. The result values stored when particular monitor is completed are displayed. If the monitor is not completed, initial value is displayed.

TEST ID	Description	Related system	Initial value (MEAS)
10:01:11	HO2S (Front) inversion cycles	HO2S	(0)
10:02:11	HO2S (Front) lean-to-rich response time		(0)
10:03:11	HO2S (Front) rich-to-lean response time		(0)
10:04:01	HO2S (Front) rich/lean inversion voltage		113
10:04:02	Middle/HO2S (Rear) rich/lean inversion voltage		113
10:05:01	HO2S (Front) lean threshold voltage		72
10:06:01	HO2S (Front) rich threshold voltage		113
10:11:11	Front and rear HO2S (RH) switching time ratio	TWC	(65535)
10:21:00	In-tank pressure evaporative purge system (small leak)	EVAP	(0)
10:22:00	In-tank pressure evaporative purge system (large leak)		(0)
10:23:00	In-tank pressure evaporative purge system (very small leak)		(0)
10:31:00	Heat radiation ratio	THERMOSTAT	(0)
10:32:00	ECT	THERMOSTAT	(65535)
10:41:00	EGR pressure variation	EGR	(32768)

# ON-BOARD DIAGNOSTIC [ENGINE CONTROL SYSTEM (FS)]

## DTC TABLE [FS]

A3U010218881W14

DTC No.	Condition	MIL	O/D off indicator light	DC	Monitor item	Memory function	Page
P0031	HO2S heater (front) circuit low	ON	—	2	O <sub>2</sub> sensor heater	×	(See 01-02B-19 DTC P0031 [FS])
P0032	HO2S heater (front) circuit high	ON	—	2	O <sub>2</sub> sensor heater	×	(See 01-02B-20 DTC P0032 [FS])
P0037	HO2S heater (rear) circuit low	ON	—	2	O <sub>2</sub> sensor heater	×	(See 01-02B-22 DTC P0037 [FS])
P0038	HO2S heater (rear) circuit high	ON	—	2	O <sub>2</sub> sensor heater	×	(See 01-02B-23 DTC P0038 [FS])
P0101	MAF circuit range/performance problem	ON	—	2	CCM	×	(See 01-02B-25 DTC P0101 [FS])
P0102	MAF circuit low input	ON	—	1	CCM	×	(See 01-02B-27 DTC P0102 [FS])
P0103	MAF circuit high input	ON	—	1	CCM	×	(See 01-02B-29 DTC P0103 [FS])
P0106	BARO circuit performance problem	ON	—	2	CCM	×	(See 01-02B-30 DTC P0106 [FS])
P0107	BARO circuit low input	ON	—	1	CCM	×	(See 01-02B-31 DTC P0107 [FS])
P0108	BARO circuit high input	ON	—	1	CCM	×	(See 01-02B-34 DTC P0108 [FS])
P0111	IAT circuit performance problem	ON	—	2	CCM	×	(See 01-02B-35 DTC P0111 [FS])
P0112	IAT circuit low input	ON	—	1	CCM	×	(See 01-02B-36 DTC P0112 [FS])
P0113	IAT circuit high input	ON	—	1	CCM	×	(See 01-02B-38 DTC P0113 [FS])
P0117	ECT circuit low input	ON	—	1	CCM	×	(See 01-02B-40 DTC P0117 [FS])
P0118	ECT circuit high input	ON	—	1	CCM	×	(See 01-02B-42 DTC P0118 [FS])
P0121	TP circuit range/performance problem	ON	—	2	CCM	×	(See 01-02B-43 DTC P0121 [FS])
P0122	TP circuit low input	ON	Flashing	1	CCM	×	(See 01-02B-46 DTC P0122 [FS])
P0123	TP circuit high input	ON	Flashing	1	CCM	×	(See 01-02B-47 DTC P0123 [FS])
P0125	Excessive time to enter closed loop fuel control	ON	—	2	CCM	×	(See 01-02B-49 DTC P0125 [FS])
P0126	Coolant thermostat stuck to open	ON	—	2	THERMOSTAT	×	(See 01-02B-50 DTC P0126, P0128 [FS])
P0128	Coolant thermostat stuck to open	ON	—	2	THERMOSTAT	×	(See 01-02B-50 DTC P0126, P0128 [FS])
P0131	HO2S (front) no inversion (low voltage stuck)	ON	—	2	CCM	×	(See 01-02B-52 DTC P0131 [FS])
P0132	HO2S (front) no inversion (high voltage stuck)	ON	—	2	CCM	×	(See 01-02B-55 DTC P0132 [FS])
P0133	HO2S (front) circuit slow response	ON	—	2	O <sub>2</sub> sensor	×	(See 01-02B-57 DTC P0133 [FS])
P0134	HO2S (front) circuit no activity detected	ON	—	2	CCM	×	(See 01-02B-61 DTC P0134 [FS])
P0138	HO2S (rear) circuit high input	ON	—	2	CCM	×	(See 01-02B-63 DTC P0138 [FS])
P0140	HO2S (rear) circuit no activity detected	ON	—	2	CCM	×	(See 01-02B-64 DTC P0140 [FS])
P0171	Fuel trim system too lean	ON	—	2	Fuel	×	(See 01-02B-67 DTC P0171 [FS])
P0172	Fuel trim system too rich	ON	—	2	Fuel	×	(See 01-02B-70 DTC P0172 [FS])

01-02B

## ON-BOARD DIAGNOSTIC [ENGINE CONTROL SYSTEM (FS)]

DTC No.	Condition	MIL	O/D off indicator light	DC	Monitor item	Memory function	Page
P0300	Random misfire detected	Flashing or ON	—	1 or 2	Misfire	×	(See 01-02B-71 DTC P0300 [FS])
P0301	Cylinder 1 misfire detected	Flashing or ON	—	1 or 2	Misfire	×	(See 01-02B-75 DTC P0301, P0302, P0303, P0304 [FS])
P0302	Cylinder 2 misfire detected	Flashing or ON	—	1 or 2	Misfire	×	(See 01-02B-75 DTC P0301, P0302, P0303, P0304 [FS])
P0303	Cylinder 3 misfire detected	Flashing or ON	—	1 or 2	Misfire	×	(See 01-02B-75 DTC P0301, P0302, P0303, P0304 [FS])
P0304	Cylinder 4 misfire detected	Flashing or ON	—	1 or 2	Misfire	×	(See 01-02B-75 DTC P0301, P0302, P0303, P0304 [FS])
P0325	Knock sensor circuit malfunction	ON	—	1	CCM	×	(See 01-02B-77 DTC P0325 [FS])
P0335	CKP sensor circuit malfunction	ON	—	1	CCM	×	(See 01-02B-79 DTC P0335 [FS])
P0340	CMP sensor circuit malfunction	ON	—	1	CCM	×	(See 01-02B-80 DTC P0340 [FS])
P0401	EGR flow insufficient detected	ON	—	2	EGR	×	(See 01-02B-82 DTC P0401 [FS])
P0402	EGR flow excessive detected	ON	—	2	EGR	×	(See 01-02B-83 DTC P0402 [FS])
P0421	Warm-up catalyst system efficiency below threshold	ON	—	2	Catalyst	×	(See 01-02B-84 DTC P0421 [FS])
P0442	Evaporative emission system leak detected (small leak)	ON	—	2	Evaporative	×	(See 01-02B-86 DTC P0442 [FS])
P0443	Evaporative emission control system purge solenoid valve circuit malfunction	OFF	—	—	Other	—	(See 01-02B-89 DTC P0443 [FS])
P0451	Fuel tank pressure sensor performance problem	ON	—	2	CCM	×	(See 01-02B-90 DTC P0451 [FS])
P0452	Fuel tank pressure sensor low input	ON	—	2	CCM	×	(See 01-02B-93 DTC P0452 [FS])
P0453	Fuel tank pressure sensor high input	ON	—	2	CCM	×	(See 01-02B-95 DTC P0453 [FS])
P0455	Evaporative emission control system leak detected (blockage or large leak)	ON	—	2	Evaporative	×	(See 01-02B-97 DTC P0455 [FS])
P0456	Evaporative emission control system leak detected (very small leak)	ON	—	2	Evaporative	×	(See 01-02B-102 DTC P0456 [FS])
P0461	Fuel gauge sender unit circuit range/performance	ON	—	2	CCM	×	(See 01-02B-104 DTC P0461 [FS])
P0462	Fuel gauge sender unit circuit low input	ON	—	2	CCM	×	(See 01-02B-105 DTC P0462 [FS])
P0463	Fuel gauge sender unit circuit high input	ON	—	2	CCM	×	(See 01-02B-107 DTC P0463 [FS])
P0464	Fuel gauge sender unit circuit performance (slosh check)	ON	—	2	CCM	×	(See 01-02B-108 DTC P0464 [FS])
P0480	Cooling fan relay malfunction	OFF	—	2	CCM	×	(See 01-02B-109 DTC P0480 [FS])
P0500	VSS circuit malfunction (MTX)	ON	—	2	CCM	×	(See 01-02B-111 DTC P0500 [FS])
	VSS circuit malfunction (ATX)	(See 05-02-6 AUTOMATIC TRANSAXLE ON-BOARD DIAGNOSTIC FUNCTION.)					
P0505	IAC valve circuit malfunction	ON	—	1	CCM	×	(See 01-02B-113 DTC P0505 [FS])
P0506	Idle control system RPM lower than expected	ON	—	2	CCM	×	(See 01-02B-115 DTC P0506 [FS])



## ON-BOARD DIAGNOSTIC [ENGINE CONTROL SYSTEM (FS)]

DTC No.	Condition	MIL	O/D off indicator light	DC	Monitor item	Memory function	Page
P0507	Idle control system RPM higher than expected	ON	—	2	CCM	×	(See 01-02B-117 DTC P0507 [FS])
P0550	PSP switch circuit malfunction	ON	—	2	CCM	×	(See 01-02B-118 DTC P0550 [FS])
P0660	VICS solenoid valve circuit malfunction	OFF	—	2	CCM	×	(See 01-02B-119 DTC P0660 [FS])
P0703	Brake switch input malfunction	ON	—	2	CCM	×	(See 01-02B-122 DTC P0703 [FS])
P0704	Clutch switch input circuit malfunction (MTX)	ON	—	2	CCM	×	(See 01-02B-123 DTC P0704 [FS])
P0705	Neutral switch input circuit malfunction (MTX)	ON	—	2	CCM	×	(See 01-02B-125 DTC P0705 [FS])
P0705	TR switch circuit malfunction (ATX)	(See 05-02-6 AUTOMATIC TRANSAXLE ON-BOARD DIAGNOSTIC FUNCTION.)					
P0706	TR switch circuit malfunction (open circuit) (ATX)	(See 05-02-6 AUTOMATIC TRANSAXLE ON-BOARD DIAGNOSTIC FUNCTION.)					
P0710	Transaxle temperature sensor circuit malfunction (open or short) (ATX)	(See 05-02-6 AUTOMATIC TRANSAXLE ON-BOARD DIAGNOSTIC FUNCTION.)					
P0711	Transaxle temperature sensor circuit range/performance (stuck) (ATX)	(See 05-02-6 AUTOMATIC TRANSAXLE ON-BOARD DIAGNOSTIC FUNCTION.)					
P0715	Input/turbine speed sensor circuit malfunction (ATX)	(See 05-02-6 AUTOMATIC TRANSAXLE ON-BOARD DIAGNOSTIC FUNCTION.)					
P0731	Gear 1 incorrect (ATX)	(See 05-02-6 AUTOMATIC TRANSAXLE ON-BOARD DIAGNOSTIC FUNCTION.)					
P0732	Gear 2 incorrect (ATX)	(See 05-02-6 AUTOMATIC TRANSAXLE ON-BOARD DIAGNOSTIC FUNCTION.)					
P0733	Gear 3 incorrect (ATX)	(See 05-02-6 AUTOMATIC TRANSAXLE ON-BOARD DIAGNOSTIC FUNCTION.)					
P0734	Gear 4 incorrect (ATX)	(See 05-02-6 AUTOMATIC TRANSAXLE ON-BOARD DIAGNOSTIC FUNCTION.)					
P0741	TCC (stuck off) (ATX)	(See 05-02-6 AUTOMATIC TRANSAXLE ON-BOARD DIAGNOSTIC FUNCTION.)					
P0742	TCC (stuck on) (ATX)	(See 05-02-6 AUTOMATIC TRANSAXLE ON-BOARD DIAGNOSTIC FUNCTION.)					
P0745	Pressure control solenoid valve malfunction (ATX)	(See 05-02-6 AUTOMATIC TRANSAXLE ON-BOARD DIAGNOSTIC FUNCTION.)					
P0751	Shift solenoid A malfunction (stuck off) (ATX)	(See 05-02-6 AUTOMATIC TRANSAXLE ON-BOARD DIAGNOSTIC FUNCTION.)					
P0752	Shift solenoid A malfunction (stuck on) (ATX)	(See 05-02-6 AUTOMATIC TRANSAXLE ON-BOARD DIAGNOSTIC FUNCTION.)					
P0753	Shift solenoid A malfunction (electrical) (ATX)	(See 05-02-6 AUTOMATIC TRANSAXLE ON-BOARD DIAGNOSTIC FUNCTION.)					
P0756	Shift solenoid B malfunction (stuck off) (ATX)	(See 05-02-6 AUTOMATIC TRANSAXLE ON-BOARD DIAGNOSTIC FUNCTION.)					
P0757	Shift solenoid B malfunction (stuck on) (ATX)	(See 05-02-6 AUTOMATIC TRANSAXLE ON-BOARD DIAGNOSTIC FUNCTION.)					
P0758	Shift solenoid B malfunction (electrical) (ATX)	(See 05-02-6 AUTOMATIC TRANSAXLE ON-BOARD DIAGNOSTIC FUNCTION.)					
P0761	Shift solenoid C malfunction (stuck off) (ATX)	(See 05-02-6 AUTOMATIC TRANSAXLE ON-BOARD DIAGNOSTIC FUNCTION.)					
P0762	Shift solenoid C malfunction (stuck on) (ATX)	(See 05-02-6 AUTOMATIC TRANSAXLE ON-BOARD DIAGNOSTIC FUNCTION.)					

01-02B

## ON-BOARD DIAGNOSTIC [ENGINE CONTROL SYSTEM (FS)]

DTC No.	Condition	MIL	O/D off indicator light	DC	Monitor item	Memory function	Page
P0763	Shift solenoid C malfunction (electrical) (ATX)	(See 05-02-6 AUTOMATIC TRANSAXLE ON-BOARD DIAGNOSTIC FUNCTION.)					
P0766	Shift solenoid D malfunction (stuck off) (ATX)	(See 05-02-6 AUTOMATIC TRANSAXLE ON-BOARD DIAGNOSTIC FUNCTION.)					
P0767	Shift solenoid D malfunction (stuck on) (ATX)	(See 05-02-6 AUTOMATIC TRANSAXLE ON-BOARD DIAGNOSTIC FUNCTION.)					
P0768	Shift solenoid D malfunction (electrical) (ATX)	(See 05-02-6 AUTOMATIC TRANSAXLE ON-BOARD DIAGNOSTIC FUNCTION.)					
P0771	Shift solenoid E malfunction (stuck off) (ATX)	(See 05-02-6 AUTOMATIC TRANSAXLE ON-BOARD DIAGNOSTIC FUNCTION.)					
P0772	Shift solenoid E malfunction (stuck on) (ATX)	(See 05-02-6 AUTOMATIC TRANSAXLE ON-BOARD DIAGNOSTIC FUNCTION.)					
P0773	Shift solenoid E malfunction (electrical) (ATX)	(See 05-02-6 AUTOMATIC TRANSAXLE ON-BOARD DIAGNOSTIC FUNCTION.)					
P1250	PRC solenoid valve circuit malfunction	OFF	—	2	CCM	×	(See 01-02B-127 DTC P1250 [FS])
P1449	CDCV circuit malfunction	OFF	—	—	Other	—	(See 01-02B-129 DTC P1449 [FS])
P1450	Evaporative emission control system malfunction (excessive vacuum)	ON	—	2	CCM	×	(See 01-02B-131 DTC P1450 [FS])
P1487	EGR boost sensor solenoid valve circuit malfunction	OFF	—	—	Other	—	(See 01-02B-133 DTC P1487 [FS])
P1496	EGR valve stepping motor coil 1 open or short	OFF	—	—	Other	—	(See 01-02B-135 DTC P1496 [FS])
P1497	EGR valve stepping motor coil 2 open or short	OFF	—	—	Other	—	(See 01-02B-137 DTC P1497 [FS])
P1498	EGR valve stepping motor coil 3 open or short	OFF	—	—	Other	—	(See 01-02B-139 DTC P1498 [FS])
P1499	EGR valve stepping motor coil 4 open or short	OFF	—	—	Other	—	(See 01-02B-141 DTC P1499 [FS])
P1512	VTCS shutter valve close stuck	ON	—	2	CCM	×	(See 01-02B-143 DTC P1512 [FS])
P1562	PCM +BB voltage low	ON	—	1	CCM	×	(See 01-02B-144 DTC P1562 [FS])
P1569	VTCS solenoid valve circuit low input	ON	—	2	CCM	×	(See 01-02B-146 DTC P1569 [FS])
P1570	VTCS solenoid valve circuit high input	ON	—	2	CCM	×	(See 01-02B-148 DTC P1570 [FS])
P1631	Generator output voltage signal no electricity	OFF	—	—	Other	×	(See 01-02B-150 DTC P1631 [FS])
P1632	Battery voltage monitor signal circuit malfunction	OFF	—	—	Other	×	(See 01-02B-152 DTC P1632 [FS])
P1633	Battery overcharge	OFF	—	—	Other	×	(See 01-02B-153 DTC P1633 [FS])
P1634	Generator terminal B circuit open	OFF	—	—	Other	×	(See 01-02B-154 DTC P1634 [FS])

# ON-BOARD DIAGNOSTIC [ENGINE CONTROL SYSTEM (FS)]

**DTC P0031 [FS]**

A3U010201084W01

01-02B

<b>DTC P0031</b>	<b>HO2S heater (front) circuit low</b>
<b>DETECTION CONDITION</b>	<ul style="list-style-type: none"> <li>PCM monitors HO2S heater (front) control signal at PCM terminal 94. If PCM turns the HO2S heater (front) off but voltage at terminal 94 still remains low, PCM determines that HO2S heater (front) circuit has malfunction.</li> </ul> <p><b>Note</b></p> <ul style="list-style-type: none"> <li>HO2S heater (front) is controlled by a duty signal.</li> </ul> <p><b>Diagnostic support note</b></p> <ul style="list-style-type: none"> <li>This is an intermittent monitor (O<sub>2</sub> sensor heater).</li> <li>MIL illuminates if PCM detects the above malfunction condition in two consecutive drive cycles.</li> <li>PENDING CODE is available if PCM detects the above malfunction condition during first drive cycle.</li> <li>FREEZE FRAME DATA is available.</li> <li>DTC is stored in PCM memory.</li> </ul>
	<p><b>POSSIBLE CAUSE</b></p> <ul style="list-style-type: none"> <li>HO2S (front) malfunction</li> <li>Open circuit between ignition switch terminal C and HO2S (front) terminal C</li> <li>Open circuit between HO2S (front) terminal D and PCM terminal 94</li> <li>Short to ground circuit between HO2S (front) terminal D and PCM terminal 94</li> <li>Poor connection at HO2S (front) or PCM connector</li> <li>PCM malfunction</li> </ul>

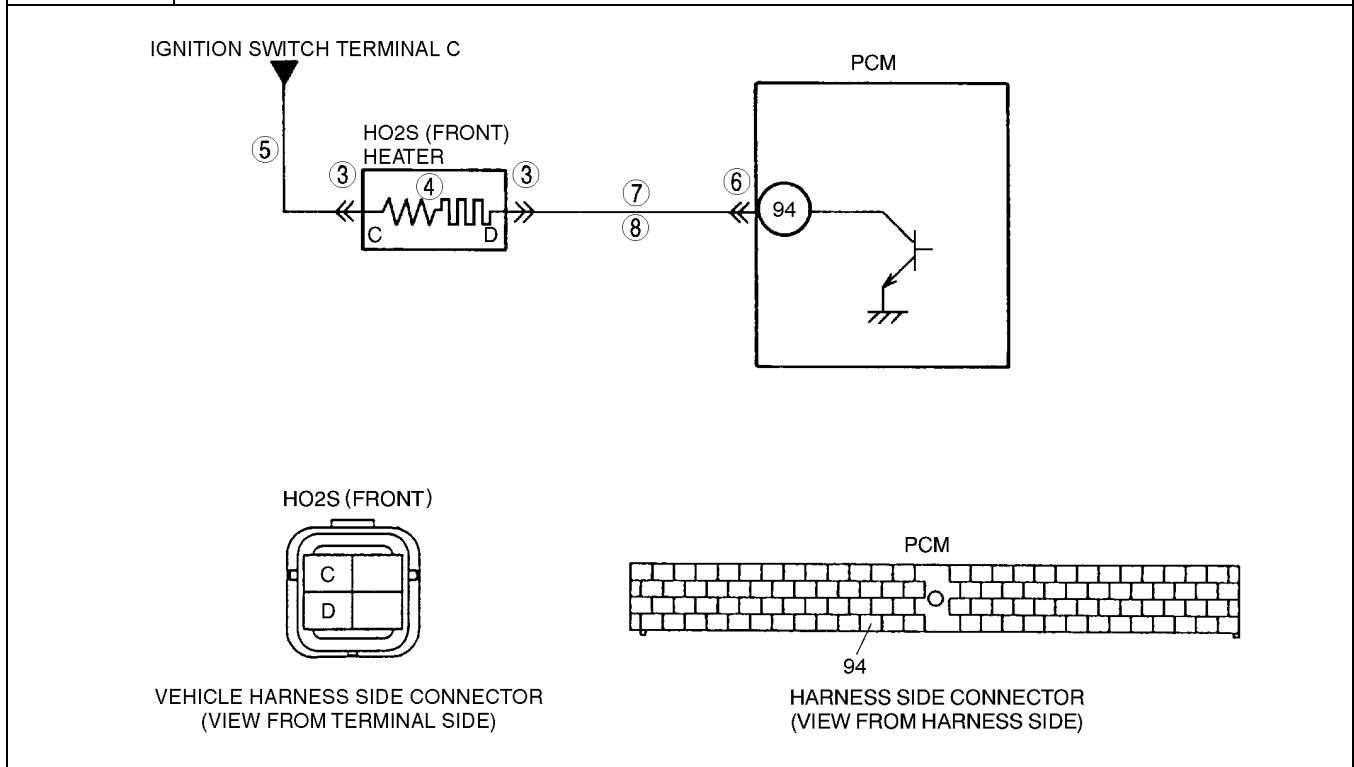

**Diagnostic procedure**

STEP	INSPECTION		ACTION
1	<b>VERIFY FREEZE FRAME DATA HAS BEEN RECORDED</b> <ul style="list-style-type: none"> <li>Has FREEZE FRAME DATA been recorded?</li> </ul>	Yes	Go to next step.
		No	Record FREEZE FRAME DATA on repair order, then go to next step.
2	<b>VERIFY RELATED REPAIR INFORMATION AVAILABILITY</b> <ul style="list-style-type: none"> <li>Check for related Service Bulletins availability.</li> <li>Is any related repair information available?</li> </ul>	Yes	Perform repair or diagnosis according to available repair information. <ul style="list-style-type: none"> <li>If vehicle is not repaired, go to next step.</li> </ul>
		No	Go to next step.
3	<b>INSPECT HO2S (FRONT) CONNECTOR FOR POOR CONNECTION</b> <ul style="list-style-type: none"> <li>Turn ignition key to OFF.</li> <li>Disconnect HO2S (front) connector.</li> <li>Check for poor connection (damaged/pulled-out pins, corrosion, etc.).</li> <li>Is there malfunction?</li> </ul>	Yes	Repair or replace terminal, then go to Step 9.
		No	Go to next step.

## ON-BOARD DIAGNOSTIC [ENGINE CONTROL SYSTEM (FS)]

STEP	INSPECTION	ACTION
4	<b>INSPECT HO2S HEATER (FRONT)</b> <ul style="list-style-type: none"> <li>Measure resistance between HO2S (front) terminals C and D (part-side).</li> <li>Is resistance <b>approx. 5.6 ohms</b>?</li> </ul>	Yes Go to next step.
		No Replace the HO2S (front), then go to Step 9.
5	<b>INSPECT POWER CIRCUIT OF HO2S HEATER (FRONT) FOR OPEN CIRCUIT</b> <ul style="list-style-type: none"> <li>Turn ignition key to ON (Engine OFF).</li> <li>Measure voltage between HO2S (front) terminal C (vehicle harness-side) and body GND.</li> <li>Is voltage <b>B+</b>?</li> </ul>	Yes Go to next step.
		No Repair or replace harness for open circuit, then go to Step 9.
6	<b>INSPECT PCM CONNECTOR FOR POOR CONNECTION</b> <ul style="list-style-type: none"> <li>Turn ignition key to OFF.</li> <li>Disconnect PCM connector.</li> <li>Check for poor connection at terminal 94 (damaged/pulled-out pins, corrosion, etc.).</li> <li>Is there malfunction?</li> </ul>	Yes Repair terminal, then go to Step 9.
		No Go to next step.
7	<b>INSPECT CONTROL CIRCUIT OF HO2S HEATER (FRONT) FOR SHORT TO GROUND</b> <ul style="list-style-type: none"> <li>Check for continuity between HO2S (front) terminal D (vehicle harness-side) and body GND.</li> <li>Is there continuity?</li> </ul>	Yes Repair or replace harness for short to ground, then go to Step 9.
		No Go to next step.
8	<b>INSPECT CONTROL CIRCUIT OF HO2S HEATER (FRONT) FOR OPEN CIRCUIT</b> <ul style="list-style-type: none"> <li>Connect breakout box with PCM connector disconnected.</li> <li>Check for continuity between HO2S (front) terminal D (vehicle harness-side) and breakout box terminal 94.</li> <li>Is there continuity?</li> </ul>	Yes Go to next step.
		No Repair or replace harness for open circuit, then go to Step 9.
9	<b>VERIFY TROUBLESHOOTING OF DTC P0031 COMPLETED</b> <ul style="list-style-type: none"> <li>Make sure to reconnect all disconnected connectors.</li> <li>Clear DTC from PCM memory using WDS or equivalent.</li> <li>Start engine and warm it up completely.</li> <li>Is same PENDING CODE of DTC present?</li> </ul>	Yes Replace PCM, then go to next step.
		No Go to next step.
10	<b>VERIFY AFTER REPAIR PROCEDURE</b> <ul style="list-style-type: none"> <li>Perform "After Repair Procedure". (See 01-02B-9 AFTER REPAIR PROCEDURE [FS].)</li> <li>Is there any DTC present?</li> </ul>	Yes Go to applicable DTC inspection. (See 01-02B-15 DTC TABLE [FS].)
		No Troubleshooting completed.

### DTC P0032 [FS]

A3U010201084W02

DTC P0032	HO2S heater (front) circuit high
<b>DETECTION CONDITION</b>	<ul style="list-style-type: none"> <li>PCM monitors HO2S heater (front) control signal at PCM terminal 94. If PCM turns HO2S heater (front) on but voltage at terminal 94 still remains high, PCM determines that HO2S heater (front) circuit has malfunction.</li> </ul> <p style="text-align: center;"><b>Note</b></p> <ul style="list-style-type: none"> <li>HO2S heater (front) is controlled by a duty signal.</li> </ul> <p><b>Diagnostic support note</b></p> <ul style="list-style-type: none"> <li>This is an intermittent monitor (O<sub>2</sub> sensor heater).</li> <li>MIL illuminates if PCM detects the above malfunction condition in two consecutive drive cycles.</li> <li>PENDING CODE is available if PCM detects the above malfunction condition during first drive cycle.</li> <li>FREEZE FRAME DATA is available.</li> <li>DTC is stored in PCM memory.</li> </ul>
<b>POSSIBLE CAUSE</b>	<ul style="list-style-type: none"> <li>Short to power circuit between HO2S (front) terminal D and PCM terminal 94</li> <li>Shorted HO2S (front) or PCM terminal</li> <li>PCM malfunction</li> </ul>

# ON-BOARD DIAGNOSTIC [ENGINE CONTROL SYSTEM (FS)]

01-02B

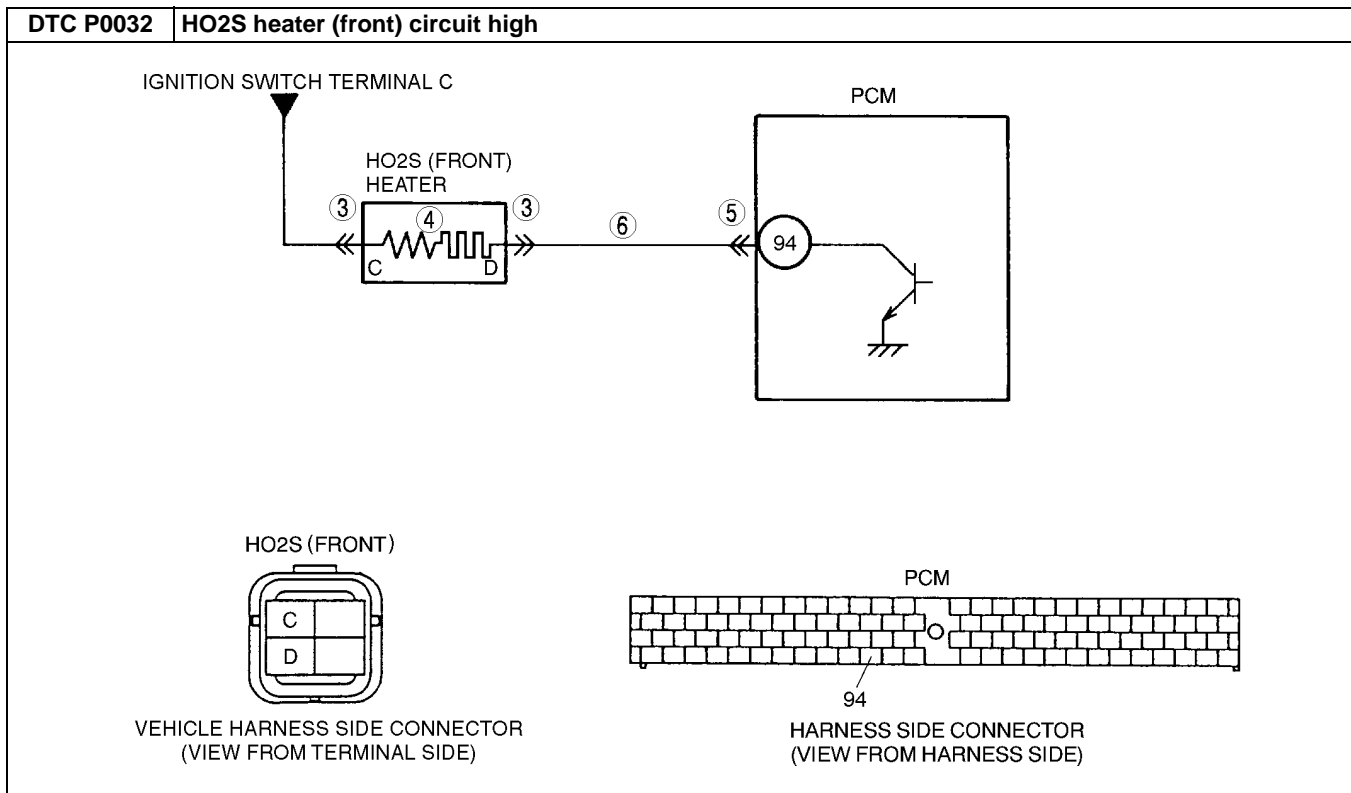

### Diagnostic procedure

STEP	INSPECTION		ACTION
1	<b>VERIFY FREEZE FRAME DATA HAS BEEN RECORDED</b> • Has FREEZE FRAME DATA been recorded?	Yes	Go to next step.
		No	Record FREEZE FRAME DATA on repair order, then go to next step.
2	<b>VERIFY RELATED REPAIR INFORMATION AVAILABILITY</b> • Check for related Service Bulletins availability. • Is any related repair information available?	Yes	Perform repair or diagnosis according to available repair information. • If vehicle is not repaired, go to next step.
		No	Go to next step.
3	<b>INSPECT HO2S (FRONT) TERMINALS</b> • Turn ignition key to OFF. • Disconnect HO2S (front) connector. • Check for bent terminals. • Is there malfunction?	Yes	Repair or replace terminal, then go to Step 7.
		No	Go to next step.
4	<b>INSPECT HO2S HEATER (FRONT)</b> • Measure resistance between HO2S (front) terminals C and D (part-side). • Is resistance <b>approx. 5.6 ohms</b> ?	Yes	Go to next step.
		No	Replace the HO2S (front), then go to Step 7.
5	<b>INSPECT PCM TERMINAL</b> • Disconnect PCM connector. • Check for bent terminal at terminal 94. • Is there malfunction?	Yes	Repair terminal, then go to Step 7.
		No	Go to next step.
6	<b>INSPECT HO2S (FRONT) HEATER CONTROL CIRCUIT FOR SHORT TO POWER CIRCUIT</b> • Turn ignition key to ON (Engine OFF). • Measure voltage between HO2S (front) terminal D (vehicle harness-side) and body ground. • Is voltage <b>B+</b> ?	Yes	Repair or replace harness for short to power circuit, then go to next step.
		No	Go to next step.
7	<b>VERIFY TROUBLESHOOTING OF DTC P0032 COMPLETED</b> • Make sure to reconnect all disconnected connectors. • Clear DTC from PCM memory using WDS or equivalent. • Start engine and warm it up completely. • Is PENDING CODE of same DTC present?	Yes	Replace PCM, then go to next step.
		No	Go to next step.

# ON-BOARD DIAGNOSTIC [ENGINE CONTROL SYSTEM (FS)]

STEP	INSPECTION		ACTION
8	<b>VERIFY AFTER REPAIR PROCEDURE</b> <ul style="list-style-type: none"> <li>Perform "After Repair Procedure". (See 01-02B-9 AFTER REPAIR PROCEDURE [FS].)</li> <li>Is there any DTC present?</li> </ul>	Yes	Go to applicable DTC inspection. (See 01-02B-15 DTC TABLE [FS].)
		No	Troubleshooting completed.

## DTC P0037 [FS]

A3U010201084W03

DTC P0037	HO2S heater (rear) circuit low
<b>DETECTION CONDITION</b>	<ul style="list-style-type: none"> <li>PCM monitors HO2S heater (rear) control signal at PCM terminal 93. If PCM turns HO2S heater (rear) off but voltage at terminal 93 still remains low, PCM determines that HO2S heater (rear) circuit has malfunction.</li> </ul> <p><b>Diagnostic support note</b></p> <ul style="list-style-type: none"> <li>This is an intermittent monitor (O<sub>2</sub> sensor heater).</li> <li>MIL illuminates if PCM detects the above malfunction condition in two consecutive drive cycles.</li> <li>PENDING CODE is available if PCM detects the above malfunction condition during first drive cycle.</li> <li>FREEZE FRAME DATA is available.</li> <li>DTC is stored in PCM memory.</li> </ul>
<b>POSSIBLE CAUSE</b>	<ul style="list-style-type: none"> <li>HO2S (rear) malfunction</li> <li>Open circuit between ignition switch terminal C and HO2S (rear) terminal C</li> <li>Open circuit between HO2S (rear) terminal D and PCM terminal 93</li> <li>Short to ground circuit between HO2S (rear) terminal D and PCM terminal 93</li> <li>Poor connection at HO2S (rear) or PCM connector</li> <li>PCM malfunction</li> </ul>

### Diagnostic procedure

STEP	INSPECTION		ACTION
1	<b>VERIFY FREEZE FRAME DATA HAS BEEN RECORDED</b> <ul style="list-style-type: none"> <li>Has FREEZE FRAME DATA been recorded?</li> </ul>	Yes	Go to next step.
		No	Record FREEZE FRAME DATA on repair order, then go to next step.
2	<b>VERIFY RELATED REPAIR INFORMATION AVAILABILITY</b> <ul style="list-style-type: none"> <li>Check for related Service Bulletins availability.</li> <li>Is any related repair information available?</li> </ul>	Yes	Perform repair or diagnosis according to available repair information. <ul style="list-style-type: none"> <li>If vehicle is not repaired, go to next step.</li> </ul>
		No	Go to next step.

## ON-BOARD DIAGNOSTIC [ENGINE CONTROL SYSTEM (FS)]

STEP	INSPECTION	ACTION	
3	<b>INSPECT HO2S (REAR) CONNECTOR FOR POOR CONNECTION</b> <ul style="list-style-type: none"> <li>• Turn ignition key to OFF.</li> <li>• Disconnect HO2S (rear) connector.</li> <li>• Check for poor connection (damaged/pulled-out pins, corrosion, etc.).</li> <li>• Is there malfunction?</li> </ul>	Yes	Repair or replace terminal, then go to Step 9.
		No	Go to next step.
4	<b>INSPECT HO2S HEATER (REAR)</b> <ul style="list-style-type: none"> <li>• Measure resistance between HO2S (rear) terminals C and D (part-side).</li> <li>• Is resistance <b>approx. 15.7 ohms</b>?</li> </ul>	Yes	Go to next step.
		No	Replace the HO2S (rear), then go to Step 9.
5	<b>INSPECT HO2S HEATER (REAR) POWER CIRCUIT FOR OPEN CIRCUIT</b> <ul style="list-style-type: none"> <li>• Turn ignition key to ON (Engine OFF).</li> <li>• Measure voltage between HO2S (rear) terminal C (vehicle harness-side) and body ground.</li> <li>• Is voltage <b>B+</b>?</li> </ul>	Yes	Go to next step.
		No	Repair or replace harness for open circuit, then go to Step 9.
6	<b>INSPECT PCM CONNECTOR FOR POOR CONNECTION</b> <ul style="list-style-type: none"> <li>• Turn ignition key to OFF.</li> <li>• Disconnect PCM connector.</li> <li>• Check for poor connection at terminal 93 (damaged/pulled-out pins, corrosion, etc.).</li> <li>• Is there malfunction?</li> </ul>	Yes	Repair terminal, then go to Step 9.
		No	Go to next step.
7	<b>INSPECT HO2S HEATER (REAR) CONTROL CIRCUIT FOR SHORT TO GROUND</b> <ul style="list-style-type: none"> <li>• Check for continuity between HO2S (rear) terminal D (vehicle harness-side) and body ground.</li> <li>• Is there continuity?</li> </ul>	Yes	Repair or replace harness for short to ground, then go to Step 9.
		No	Go to next step.
8	<b>INSPECT HO2S HEATER (REAR) CONTROL CIRCUIT FOR OPEN CIRCUIT</b> <ul style="list-style-type: none"> <li>• Connect breakout box with PCM connector disconnected.</li> <li>• Check for continuity between HO2S (rear) terminal D (vehicle harness-side) and breakout box terminal 93.</li> <li>• Is there continuity?</li> </ul>	Yes	Go to next step.
		No	Repair or replace harness for open circuit, then go to Step 9.
9	<b>VERIFY TROUBLESHOOTING OF DTC P0037 COMPLETED</b> <ul style="list-style-type: none"> <li>• Make sure to reconnect all disconnected connectors.</li> <li>• Clear DTC from PCM memory using WDS or equivalent.</li> <li>• Start engine and warm it up completely.</li> <li>• Is PENDING CODE of same DTC present?</li> </ul>	Yes	Replace PCM, then go to next step.
		No	Go to next step.
10	<b>VERIFY AFTER REPAIR PROCEDURE</b> <ul style="list-style-type: none"> <li>• Perform "After Repair Procedure". (See 01-02B-9 AFTER REPAIR PROCEDURE [FS].)</li> <li>• Is there any DTC present?</li> </ul>	Yes	Go to applicable DTC inspection. (See 01-02B-15 DTC TABLE [FS].)
		No	Troubleshooting completed.

01-02B

### DTC P0038 [FS]

A3U010201084W04

DTC P0038	HO2S heater (rear) circuit high
<b>DETECTION CONDITION</b>	<ul style="list-style-type: none"> <li>• PCM monitors HO2S heater (rear) control signal at PCM terminal 93. If PCM turns HO2S heater (rear) on but voltage at terminal 93 still remains high, PCM determines that HO2S heater (rear) circuit has malfunction.</li> </ul> <p><b>Diagnostic support note</b></p> <ul style="list-style-type: none"> <li>• This is an intermittent monitor (O<sub>2</sub> sensor heater).</li> <li>• MIL illuminates if PCM detects the above malfunction condition in two consecutive drive cycles.</li> <li>• PENDING CODE is available if PCM detects the above malfunction condition during first drive cycle.</li> <li>• FREEZE FRAME DATA is available.</li> <li>• DTC is stored in PCM memory.</li> </ul>

# ON-BOARD DIAGNOSTIC [ENGINE CONTROL SYSTEM (FS)]

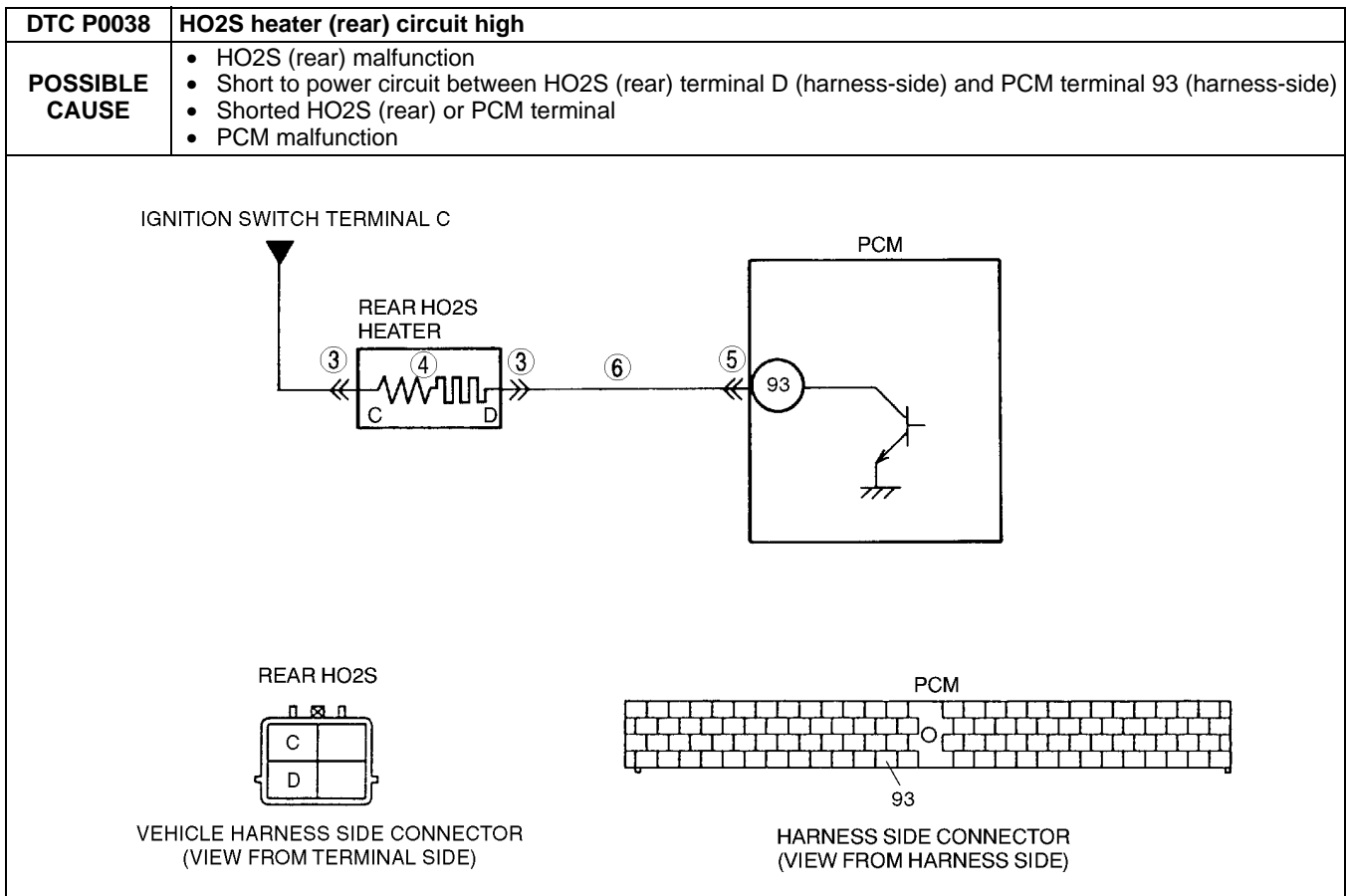

### Diagnostic procedure

STEP	INSPECTION		ACTION
1	<b>VERIFY FREEZE FRAME DATA HAS BEEN RECORDED</b> <ul style="list-style-type: none"> <li>Has FREEZE FRAME DATA been recorded?</li> </ul>	Yes	Go to next step.
		No	Record FREEZE FRAME DATA on repair order, then go to next step.
2	<b>VERIFY RELATED REPAIR INFORMATION AVAILABILITY</b> <ul style="list-style-type: none"> <li>Check for related Service Bulletins availability.</li> <li>Is any related repair information available?</li> </ul>	Yes	Perform repair or diagnosis according to available repair information. <ul style="list-style-type: none"> <li>If vehicle is not repaired, go to next step.</li> </ul>
		No	Go to next step.
3	<b>INSPECT HO2S (REAR) TERMINAL</b> <ul style="list-style-type: none"> <li>Turn ignition key to OFF.</li> <li>Disconnect HO2S (rear) connector.</li> <li>Check for bent terminals.</li> <li>Is there malfunction?</li> </ul>	Yes	Repair or replace terminal, then go to Step 7.
		No	Go to next step.
4	<b>INSPECT HO2S HEATER (REAR)</b> <ul style="list-style-type: none"> <li>Measure resistance between HO2S (rear) terminals C and D (part-side).</li> <li>Is resistance <b>approx. 15.7 ohms</b></li> </ul>	Yes	Go to next step.
		No	Replace the HO2S (rear), then go to Step 7.
5	<b>INSPECT PCM TERMINAL</b> <ul style="list-style-type: none"> <li>Disconnect PCM connector.</li> <li>Check for bent terminal at terminal 93.</li> <li>Is there malfunction?</li> </ul>	Yes	Repair terminal, then go to Step 7.
		No	Go to next step.
6	<b>INSPECT HO2S (REAR) HEATER CONTROL CIRCUIT FOR SHORT TO POWER</b> <ul style="list-style-type: none"> <li>Turn ignition key to ON (Engine OFF).</li> <li>Measure voltage between HO2S (rear) terminal D (vehicle harness-side) and body ground.</li> <li>Is voltage <b>B+</b>?</li> </ul>	Yes	Repair or replace harness for short to power circuit, then go to next step.
		No	Go to next step.



## ON-BOARD DIAGNOSTIC [ENGINE CONTROL SYSTEM (FS)]

STEP	INSPECTION	ACTION	
7	<b>VERIFY TROUBLESHOOTING OF DTC P0038 COMPLETED</b> <ul style="list-style-type: none"> <li>Make sure to reconnect all disconnected connectors.</li> <li>Clear DTC from PCM memory using WDS or equivalent.</li> <li>Start engine and warm it up completely.</li> <li>Is PENDING CODE of same DTC present?</li> </ul>	Yes	Replace PCM, then go to next step.
		No	Go to next step.
8	<b>VERIFY AFTER REPAIR PROCEDURE</b> <ul style="list-style-type: none"> <li>Perform "After Repair Procedure". (See 01-02B-9 AFTER REPAIR PROCEDURE [FS].)</li> <li>Is there any DTC present?</li> </ul>	Yes	Go to applicable DTC inspection. (See 01-02B-15 DTC TABLE [FS].)
		No	Troubleshooting completed.

01-02B

### DTC P0101 [FS]

A3U010201084W05

DTC P0101	MAF circuit range/performance problem
<b>DETECTION CONDITION</b>	<ul style="list-style-type: none"> <li>PCM compares actual input signal from MAF sensor with expected input signal from MAF sensor which PCM calculates by engine speed. If mass intake air flow amount is <b>above 83.5 g/s {11.05 lb/min}</b> for <b>5 seconds</b> and engine speed is <b>less than 2,000 rpm</b> with engine running, PCM determines that detected mass intake air flow amount is too high.</li> <li>PCM compares actual input signal from MAF sensor with expected input signal from MAF sensor which PCM calculates by input voltage from TP sensor. If mass intake air flow amount is <b>below 5 g/s {0.66 lb/min}</b> for <b>5 seconds</b> and throttle opening angle is <b>above 50%</b> with engine running, PCM determines that detected mass intake air flow amount is too low.</li> </ul> <p><b>Diagnostic support note</b></p> <ul style="list-style-type: none"> <li>This is a continuous monitor (CCM).</li> <li>MIL illuminates if PCM detects the above malfunction condition in two consecutive drive cycles.</li> <li>PENDING CODE is available if PCM detects the above malfunction condition during first drive cycle.</li> <li>FREEZE FRAME DATA is available.</li> <li>DTC is stored in PCM memory.</li> </ul>
<b>POSSIBLE CAUSE</b>	<ul style="list-style-type: none"> <li>MAF sensor malfunction</li> <li>TP sensor malfunction</li> <li>Electrical corrosion in MAF signal circuit</li> <li>Electrical corrosion in MAF RETURN circuit</li> <li>Voltage drops in MAF signal circuit</li> <li>Voltage drops in ground circuit</li> </ul>

### Diagnostic procedure

STEP	INSPECTION	ACTION	
1	<b>VERIFY FREEZE FRAME DATA HAS BEEN RECORDED</b> <ul style="list-style-type: none"> <li>Has FREEZE FRAME DATA been recorded?</li> </ul>	Yes	Go to next step.
		No	Record FREEZE FRAME DATA on repair order, then go to next step.
2	<b>VERIFY RELATED REPAIR INFORMATION AVAILABILITY</b> <ul style="list-style-type: none"> <li>Check for related Service Bulletins availability.</li> <li>Is any related repair information available?</li> </ul>	Yes	Perform repair or diagnosis according to available repair information. <ul style="list-style-type: none"> <li>If vehicle is not repaired, go to next step.</li> </ul>
		No	Go to next step.
3	<b>VERIFY CURRENT INPUT SIGNAL STATUS-IS CONCERN INTERMITTENT OR CONSTANT</b> <ul style="list-style-type: none"> <li>Connect WDS or equivalent to DLC-2.</li> <li>Start the engine.</li> <li>Access ECT, RPM and MAF PIDs.</li> <li>Warm up the engine until ECT PID is <b>above 70°C {158°F}</b>.</li> <li>Read MAF PID while RPM PID is <b>below 2,000 rpm</b>.</li> <li>Is MAF PID reading <b>above 83.5 g/s {11.05 lb/min}</b>?</li> </ul>	Yes	Go to next step.
		No	Intermittent concern exists. Go to INTERMITTENT CONCERN TROUBLESHOOTING procedure. (See 01-03B-4 INTERMITTENT CONCERN TROUBLESHOOTING [FS].)

## ON-BOARD DIAGNOSTIC [ENGINE CONTROL SYSTEM (FS)]

STEP	INSPECTION	ACTION	
4	<b>VERIFY CURRENT INPUT SIGNAL STATUS-IS CONCERN INTERMITTENT OR CONSTANT</b> <ul style="list-style-type: none"> <li>• Connect WDS or equivalent to DLC-2.</li> <li>• Start the engine.</li> <li>• Access ECT, TP and MAF PIDs.</li> <li>• Warm up the engine until ECT PID is <b>above 70°C {158°F}</b>.</li> <li>• Drive the vehicle.</li> <li>• Read MAF PID while TP PID is <b>above 50%</b>.</li> <li>• Is MAF PID reading <b>below 5 g/s {0.66 lb/min}</b>?</li> </ul>	Yes	Make sure that TP sensor resistance changes smoothly while gradually opening throttle valve. <ul style="list-style-type: none"> <li>• If not, replace TP sensor and go to step 7.</li> <li>• For others, go to next step .</li> </ul>
		No	Intermittent concern exists. Go to INTERMITTENT CONCERN TROUBLESHOOTING procedure. (See 01-03B-4 INTERMITTENT CONCERN TROUBLESHOOTING [FS].)
5	<b>INSPECT MAF SENSOR CONNECTOR FOR POOR CONNECTION</b> <ul style="list-style-type: none"> <li>• Turn ignition key to OFF.</li> <li>• Disconnect MAF sensor connector.</li> <li>• Check for poor connection (damaged/pulled-out terminals, corrosion, etc.).</li> <li>• Is there malfunction?</li> </ul>	Yes	Repair or replace suspected terminal or MAF sensor, then go to Step 7.
		No	Go to next step.
6	<b>INSPECT PCM CONNECTOR FOR POOR CONNECTION</b> <ul style="list-style-type: none"> <li>• Disconnect PCM connector.</li> <li>• Check for poor connection (damaged/pulled-out pins, corrosion, etc.).</li> <li>• Is there malfunction?</li> </ul>	Yes	Repair terminal, then go to next step.
		No	Replace MAF sensor, then go to next step.
7	<b>VERIFY TROUBLESHOOTING OF DTC P0101 COMPLETED</b> <ul style="list-style-type: none"> <li>• Make sure to reconnect all disconnected connectors.</li> <li>• Turn ignition key to ON (Engine OFF).</li> <li>• Clear DTC from memory using WDS or equivalent.</li> <li>• Start the engine.</li> <li>• Access ECT, TP, RPM and MAF PIDs using WDS or equivalent.</li> <li>• Warm up the engine until ECT PID is reading <b>above 70°C {158°F}</b>.</li> <li>• Read MAF and RPM PIDs.</li> </ul> <p><b>Note</b></p> <ul style="list-style-type: none"> <li>• MAF PID should indicate <b>below 83.5 g/s {11.05 lb/min}</b> while RPM PID is <b>below 2,000 rpm</b>.</li> </ul> <ul style="list-style-type: none"> <li>• Drive the vehicle and read TP and MAF PIDs.</li> </ul> <p><b>Note</b></p> <ul style="list-style-type: none"> <li>• Verify PIDs reading are within specifications <b>more than 5 seconds</b>.               <ul style="list-style-type: none"> <li>— MAF PID: <b>above 5 g/s {0.66 lb/min}</b></li> <li>— TP PID: <b>above 50%</b></li> </ul> </li> </ul> <ul style="list-style-type: none"> <li>• Is PENDING CODE of same DTC present?</li> </ul>	Yes	Replace PCM, then go to next step.
		No	Go to next step.
8	<b>VERIFY AFTER REPAIR PROCEDURE</b> <ul style="list-style-type: none"> <li>• Perform "After Repair Procedure". (See 01-02B-9 AFTER REPAIR PROCEDURE [FS].)</li> <li>• Is there any DTC present?</li> </ul>	Yes	Go to applicable DTC inspection. (See 01-02B-15 DTC TABLE [FS].)
		No	Troubleshooting completed.

# ON-BOARD DIAGNOSTIC [ENGINE CONTROL SYSTEM (FS)]

DTC P0102 [FS]

A3U010201084W06

01-02B

<b>DTC P0102</b>	<b>MAF circuit low input</b>
<b>DETECTION CONDITION</b>	<ul style="list-style-type: none"> <li>PCM monitors input voltage from MAF sensor. If input voltage at PCM terminal 88 is <b>below 0.86 V</b>, PCM determines that MAF circuit has a malfunction.</li> </ul> <p><b>Diagnostic support note</b></p> <ul style="list-style-type: none"> <li>This is a continuous monitor (CCM).</li> <li>MIL illuminates if PCM detects the above malfunction condition during first drive cycle. Therefore, PENDING CODE is not available.</li> <li>FREEZE FRAME DATA is available.</li> <li>DTC is stored in PCM memory.</li> </ul>
<b>POSSIBLE CAUSE</b>	<ul style="list-style-type: none"> <li>MAF sensor malfunction</li> <li>Connector or terminal malfunction</li> <li>Short to ground in wiring between MAF sensor terminal C and PCM terminal 88</li> <li>Open circuit in wiring between MAF sensor terminal C and PCM terminal 88</li> <li>PCM malfunction</li> <li>Open circuit in wiring between MAF sensor terminal B and PCM terminal 77</li> <li>Open circuit in wiring between main relay and MAF sensor terminal A</li> </ul>

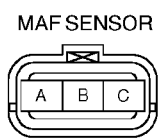
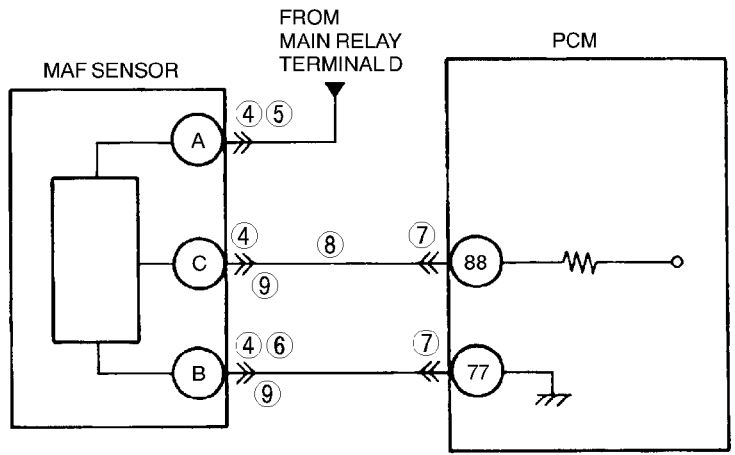

MAF SENSOR  
HARNESS SIDE CONNECTOR  
(VIEW FROM TERMINAL SIDE)

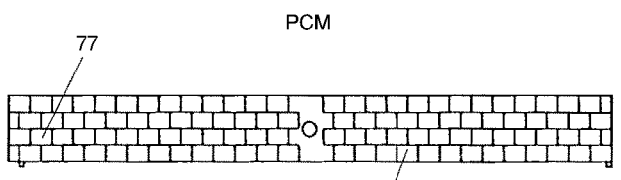

PCM  
HARNESS SIDE CONNECTOR  
(VIEW FROM HARNESS SIDE)

**Diagnostic procedure**

STEP	INSPECTION		ACTION
1	<b>VERIFY FREEZE FRAME DATA HAS BEEN RECORDED</b> <ul style="list-style-type: none"> <li>Has FREEZE FRAME DATA been recorded?</li> </ul>	Yes	Go to next step.
		No	Record FREEZE FRAME DATA on repair order, then go to next step.
2	<b>VERIFY RELATED REPAIR INFORMATION AVAILABILITY</b> <ul style="list-style-type: none"> <li>Check for related Service Bulletins availability.</li> <li>Is any related repair information available?</li> </ul>	Yes	Perform repair or diagnosis according to available repair information. <ul style="list-style-type: none"> <li>If vehicle is not repaired, go to next step.</li> </ul>
		No	Go to next step.
3	<b>VERIFY CURRENT INPUT SIGNAL STATUS-IS CONCERN INTERMITTENT OR CONSTANT</b> <ul style="list-style-type: none"> <li>Connect WDS or equivalent to DLC-2.</li> <li>Start engine.</li> <li>Access MAF PID.</li> <li>Is MAF PID <b>above 0 g/s</b> and <b>217.8 g/s</b> or <b>below</b>?</li> </ul>	Yes	Intermittent concern exists. Go to INTERMITTENT CONCERN TROUBLESHOOTING procedure. (See 01-03B-4 INTERMITTENT CONCERN TROUBLESHOOTING [FS].)
		No	Go to next step.

## ON-BOARD DIAGNOSTIC [ENGINE CONTROL SYSTEM (FS)]

STEP	INSPECTION	ACTION	
4	<b>INSPECT MAF SENSOR CONNECTOR FOR POOR CONNECTION</b> <ul style="list-style-type: none"> <li>• Turn ignition key to OFF.</li> <li>• Disconnect MAF sensor connector.</li> <li>• Check for poor connection (damaged/pulled-out terminals, corrosion, etc.).</li> <li>• Is there malfunction?</li> </ul>	Yes	Repair or replace terminals, then go to Step 10.
		No	Go to next step.
5	<b>CHECK POWER SUPPLY CIRCUIT FOR OPEN CURCUIT</b> <ul style="list-style-type: none"> <li>• Turn ignition key to ON (Engine OFF).</li> <li>• Check voltage at MAF sensor terminal A (harness-side).</li> <li>• Is voltage <b>B+</b>?</li> </ul>	Yes	Go to next step.
		No	Inspect for open circuit in wiring harness between MAF sensor terminal A (harness-side) and main relay. Repair or replace harness, then go to Step 10.
6	<b>INSPECT MAF SENSOR GROUND CIRCUIT FOR OPEN</b> <ul style="list-style-type: none"> <li>• Check for continuity between MAF sensor terminal B (harness-side) and body ground.</li> <li>• Is there continuity?</li> </ul>	Yes	Go to next step.
		No	Check for open circuit between PCM terminal 36 (harness-side) and MAF sensor terminal B (harness-side). Repair or replace suspected harness, then go to Step 10.
7	<b>INSPECT PCM CONNECTOR FOR POOR CONNECTION</b> <ul style="list-style-type: none"> <li>• Turn ignition key to OFF.</li> <li>• Disconnect PCM connector.</li> <li>• Check for poor connection (damaged/pulled-out terminals, corrosion, etc.).</li> <li>• Is there malfunction?</li> </ul>	Yes	Repair terminal, then go to Step 10.
		No	Go to next step.
8	<b>INSPECT MAF SENSOR SIGNAL CIRCUIT FOR OPEN CIRCUIT</b> <ul style="list-style-type: none"> <li>• Connect breakout box with PCM disconnected.</li> <li>• Check for continuity between MAF sensor terminal C (harness-side) and breakout box terminal 88 (harness-side).</li> <li>• Is there continuity?</li> </ul>	Yes	Go to next step.
		No	Repair or replace suspected harness, then go to Step 10.
9	<b>INSPECT MAF SENSOR SIGNAL CIRCUIT FOR SHORTS</b> <ul style="list-style-type: none"> <li>• Check continuity between following circuits:                             <ul style="list-style-type: none"> <li>— MAF sensor terminal C (harness-side) and body ground</li> <li>— MAF sensor connector terminal B (harness-side) and C (harness-side)</li> </ul> </li> <li>• Is there continuity?</li> </ul>	Yes	Repair or replace suspected harness, then go to next step.
		No	Go to next step.
10	<b>VERIFY TROUBLESHOOTING OF DTC P0102 COMPLETED</b> <ul style="list-style-type: none"> <li>• Make sure to reconnect all disconnected connectors.</li> <li>• Start engine.</li> <li>• Clear DTC from memory using WDS or equivalent.</li> <li>• Access MAF PID.</li> </ul> <p><b>Note</b></p> <ul style="list-style-type: none"> <li>• MAF PID should indicate <b>above 0 g/s</b> and <b>217.8 g/s or below</b>.</li> </ul> <ul style="list-style-type: none"> <li>• Is same DTC present?</li> </ul>	Yes	Replace PCM, then go to next step.
		No	Go to next step.
11	<b>VERIFY AFTER REPAIR PROCEDURE</b> <ul style="list-style-type: none"> <li>• Perform "After Repair Procedure". (See 01-02B-9 AFTER REPAIR PROCEDURE [FS].)</li> <li>• Is there any DTC present?</li> </ul>	Yes	Go to applicable DTC inspection. (See 01-02B-15 DTC TABLE [FS].)
		No	Troubleshooting completed.

# ON-BOARD DIAGNOSTIC [ENGINE CONTROL SYSTEM (FS)]

**DTC P0103 [FS]**

A3U010201084W07

01-02B

<b>DTC P0103</b>	<b>MAF circuit high input</b>
<b>DETECTION CONDITION</b>	<ul style="list-style-type: none"> <li>PCM monitors input voltage from MAF sensor after ignition key is turned on. If input voltage at PCM terminal 88 is <b>above 4.90 V</b>, PCM determines that MAF circuit has a malfunction.</li> </ul> <p><b>Diagnostic support note</b></p> <ul style="list-style-type: none"> <li>This is a continuous monitor (CCM).</li> <li>MIL illuminates if PCM detects the above malfunction condition during first drive cycle. Therefore, PENDING CODE is not available.</li> <li>FREEZE FRAME DATA is available.</li> <li>DTC is stored in PCM memory.</li> </ul>
<b>POSSIBLE CAUSE</b>	<ul style="list-style-type: none"> <li>MAF sensor malfunction</li> <li>Connector or terminal malfunction</li> <li>Short to power circuit in wiring between MAF sensor terminal C and PCM terminal 88</li> </ul>

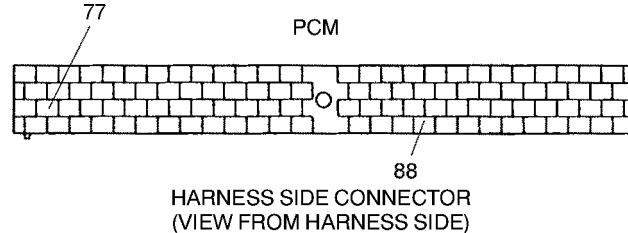
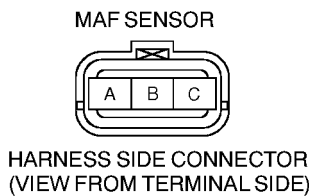
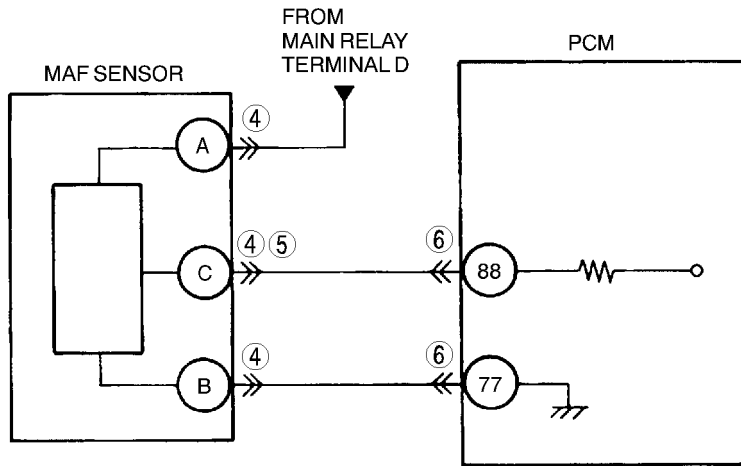

**Diagnostic procedure**

STEP	INSPECTION		ACTION
1	<b>VERIFY FREEZE FRAME DATA HAS BEEN RECORDED</b> <ul style="list-style-type: none"> <li>Has FREEZE FRAME DATA been recorded?</li> </ul>	Yes	Go to next step.
		No	Record FREEZE FRAME DATA on repair order, then go to next step.
2	<b>VERIFY RELATED REPAIR INFORMATION AVAILABILITY</b> <ul style="list-style-type: none"> <li>Check for related Service Bulletins availability.</li> <li>Is any related repair information available?</li> </ul>	Yes	Perform repair or diagnosis according to available repair information. <ul style="list-style-type: none"> <li>If vehicle is not repaired, then go to next step.</li> </ul>
		No	Go to next step.
3	<b>VERIFY CURRENT INPUT SIGNAL STATUS-IS CONCERN INTERMITTENT OR CONSTANT</b> <ul style="list-style-type: none"> <li>Connect WDS or equivalent to DLC-2.</li> <li>Start engine.</li> <li>Access MAF PID.</li> <li>Is MAF PID <b>above 0 g/s</b> and <b>217.8 g/s or below?</b></li> </ul>	Yes	Intermittent concern exists. Go to INTERMITTENT CONCERN TROUBLESHOOTING procedure. (See 01-03B-4 INTERMITTENT CONCERN TROUBLESHOOTING [FS].)
		No	Go to next step.
4	<b>INSPECT MAF SENSOR CONNECTOR FOR POOR CONNECTION</b> <ul style="list-style-type: none"> <li>Turn ignition key to OFF.</li> <li>Disconnect the MAF sensor connector.</li> <li>Check for bent terminal.</li> <li>Is there malfunction?</li> </ul>	Yes	Repair or replace terminals, then go to Step 7.
		No	Go to next step.

## ON-BOARD DIAGNOSTIC [ENGINE CONTROL SYSTEM (FS)]

STEP	INSPECTION	ACTION	
5	<b>INSPECT MAF SIGNAL CIRCUIT FOR SHORT TO POWER CIRCUIT</b> <ul style="list-style-type: none"> <li>Turn ignition key to ON (Engine OFF).</li> <li>Measure voltage between MAF sensor terminal C (harness-side) and body ground.</li> <li>Is voltage <b>0 V</b>?</li> </ul>	Yes	Go to next step.
		No	Repair or replace suspected harness, then go to Step 7.
6	<b>INSPECT PCM CONNECTOR FOR POOR CONNECTION</b> <ul style="list-style-type: none"> <li>Turn ignition key to OFF.</li> <li>Disconnect PCM connector.</li> <li>Check for bent terminals.</li> <li>Is there malfunction?</li> </ul>	Yes	Repair terminal, then go to Step 7.
		No	Go to next step.
7	<b>VERIFY TROUBLESHOOTING OF DTC P0103 COMPLETED</b> <ul style="list-style-type: none"> <li>Make sure to reconnect all disconnected connectors.</li> <li>Start engine.</li> <li>Clear DTC from memory using WDS or equivalent.</li> <li>Access MAF PID.</li> </ul> <p><b>Note</b></p> <ul style="list-style-type: none"> <li>MAF PID should indicate <b>above 0 g/s</b> and <b>217.8 g/s or below</b>.</li> </ul> <ul style="list-style-type: none"> <li>Is same DTC present?</li> </ul>	Yes	Replace PCM, then go to next step.
		No	Go to next step.
8	<b>VERIFY AFTER REPAIR PROCEDURE</b> <ul style="list-style-type: none"> <li>Perform "After Repair Procedure". (See 01-02B-9 AFTER REPAIR PROCEDURE [FS].)</li> <li>Is there any DTC present?</li> </ul>	Yes	Go to applicable DTC inspection. (See 01-02B-15 DTC TABLE [FS].)
		No	Troubleshooting completed.

### DTC P0106 [FS]

A3U010201084W08

DTC P0106	BARO circuit performance problem
<b>DETECTION CONDITION</b>	<ul style="list-style-type: none"> <li>PCM monitors differences between intake manifold vacuum and atmospheric pressure at idle, which EGR boost sensor detects by switching EGR boost sensor solenoid. If difference is <b>below 6.43 kPa {48.2 mmHg, 1.90 inHg}</b>, PCM determines that there is EGR boost sensor performance problem.</li> </ul> <p><b>Diagnostic support note</b></p> <ul style="list-style-type: none"> <li>This is a continuous monitor (CCM).</li> <li>MIL illuminates if PCM detects the above malfunction condition in two consecutive drive cycles.</li> <li>PENDING CODE is available if PCM detects the above malfunction condition during first drive cycle.</li> <li>FREEZE FRAME DATA is available.</li> <li>DTC is stored in PCM memory.</li> </ul>
<b>POSSIBLE CAUSE</b>	<ul style="list-style-type: none"> <li>EGR boost sensor malfunction or substandard performance</li> <li>EGR boost sensor solenoid malfunction</li> <li>Loose, damaged, misconnected, clogged or frozen moisture in vacuum hose from EGR boost sensor solenoid to EGR boost sensor</li> <li>PCM malfunction</li> <li>Loose, damaged, misconnected, clogged or frozen moisture in vacuum hose from EGR boost sensor solenoid to EGR valve</li> </ul>

### Diagnostic procedure

STEP	INSPECTION	ACTION	
1	<b>VERIFY FREEZE FRAME DATA HAS BEEN RECORDED</b> <ul style="list-style-type: none"> <li>Has FREEZE FRAME DATA been recorded?</li> </ul>	Yes	Go to next step.
		No	Record FREEZE FRAME DATA on repair order, then go to next step.
2	<b>VERIFY RELATED REPAIR INFORMATION AVAILABILITY</b> <ul style="list-style-type: none"> <li>Check for related Service Bulletins availability.</li> <li>Is any related repair information available?</li> </ul>	Yes	Perform repair or diagnosis according to available repair information. <ul style="list-style-type: none"> <li>If vehicle is not repaired, go to next step.</li> </ul>
		No	Go to next step.
3	<b>VERIFY STORED DTC</b> <ul style="list-style-type: none"> <li>Turn ignition key to OFF then start engine.</li> <li>Has DTC P1487 been stored?</li> </ul>	Yes	Inspect and repair DTC P1487.
		No	Go to next step.

## 01-02B-30

## ON-BOARD DIAGNOSTIC [ENGINE CONTROL SYSTEM (FS)]

STEP	INSPECTION	ACTION	
4	<b>IDENTIFY TRIGGER DTC FOR FREEZE FRAME DATA</b> • Is DTC P0106 on FREEZE FRAME DATA?	Yes	Go to next step.
		No	Go to troubleshooting procedures for DTC on FREEZE FRAME DATA.
5	<b>INSPECT CONNECTION OF EGR BOOST SENSING RELATED VACUUM HOSES</b> • Inspect the following vacuum hoses for looseness, damage, improper connection and/or clogging. — From EGR boost sensor to EGR boost sensor solenoid — From EGR boost sensor solenoid to intake manifold • Are they okay?	Yes	Go to next step.
		No	Repair or replace vacuum hose, then go to Step 9.
6	<b>INSPECT EGR BOOST SENSOR SOLENOID AIR FILTER FOR CLOGGING</b> • Has EGR boost sensor solenoid air filter been clogged?	Yes	Repair air clogging, then go to Step 9.
		No	Go to next step.
7	<b>INSPECT EGR BOOST SENSOR SOLENOID VALVE FOR WHETHER STUCK OPEN OR CLOSED</b> • Inspect EGR boost sensor solenoid valve. (See 01-16-17 EGR BOOST SENSOR SOLENOID VALVE INSPECTION) • Is EGR boost sensor solenoid okay?	Yes	Go to next step.
		No	Replace EGR boost sensor solenoid, then go to Step 9.
8	<b>INSPECT EGR BOOST SENSOR FOR WHETHER STUCK OPEN OR CLOSED</b> • Inspect EGR boost sensor. (See 01-40B-39 EGR BOOST SENSOR INSPECTION [FS].) • Is EGR boost sensor okay?	Yes	Go to next step.
		No	Replace EGR boost sensor, then go to next step.
9	<b>VERIFY TROUBLESHOOTING OF DTC P0106 COMPLETED</b> • Make sure to reconnect all disconnected connectors. • Turn ignition key to ON (Engine OFF). • Clear DTC from memory using WDS or equivalent. • Run OBD-II DRIVE MODE 1, 2 and 3. (See 01-02B-10 OBD-II DRIVE MODE [FS].) • Stop vehicle. • Is same DTC present?	Yes	Replace PCM, then go to next step.
		No	Go to next step.
10	<b>VERIFY AFTER REPAIR PROCEDURE</b> • Perform "After Repair Procedure". (See 01-02B-9 AFTER REPAIR PROCEDURE [FS].) • Is there any DTC present?	Yes	Go to applicable DTC inspection. (See 01-02B-15 DTC TABLE [FS].)
		No	Troubleshooting completed.

01-02B

### DTC P0107 [FS]

A3U010201084W09

DTC P0107	BARO circuit low input
<b>DETECTION CONDITION</b>	<ul style="list-style-type: none"> <li>PCM monitors input voltage from EGR boost sensor when monitoring conditions are met. If input voltage at PCM terminal 34 is <b>below 0.35 V</b>, PCM determines that EGR boost sensor circuit is malfunctioning.</li> </ul> <p><b>MONITORING CONDITIONS</b></p> <ul style="list-style-type: none"> <li>Intake air temperature is <b>above 10 °C {50 °F}</b>.</li> <li>EGR boost sensor solenoid is turned OFF. (Barometric pressure is applied to EGR boost sensor.)</li> </ul> <p><b>Diagnostic support note</b></p> <ul style="list-style-type: none"> <li>This is a continuous monitor (CCM).</li> <li>MIL illuminates if PCM detects the above malfunction condition during first drive cycle. Therefore, PENDING CODE is not available.</li> <li>FREEZE FRAME DATA is available.</li> <li>DTC is stored in PCM memory.</li> </ul>

## ON-BOARD DIAGNOSTIC [ENGINE CONTROL SYSTEM (FS)]

<b>DTC P0107</b>	<b>BARO circuit low input</b>
<b>POSSIBLE CAUSE</b>	<ul style="list-style-type: none"> <li>EGR boost sensor malfunction</li> <li>Connector or terminal malfunction</li> <li>Short to ground in wiring between EGR boost sensor terminal A and PCM terminal 34</li> <li>Open circuit in wiring between EGR boost sensor terminal C and PCM terminal 90</li> <li>PCM malfunction</li> </ul>

### Diagnostic procedure

STEP	INSPECTION		ACTION
1	<b>VERIFY FREEZE FRAME DATA HAS BEEN RECORDED</b> <ul style="list-style-type: none"> <li>Has FREEZE FRAME DATA been recorded?</li> </ul>	Yes	Go to next step.
		No	Record FREEZE FRAME DATA on repair order, then go to next step.
2	<b>VERIFY RELATED REPAIR INFORMATION AVAILABILITY</b> <ul style="list-style-type: none"> <li>Check for related Service Bulletins availability.</li> <li>Is any related repair information available?</li> </ul>	Yes	Perform repair or diagnosis according to available repair information. <ul style="list-style-type: none"> <li>If vehicle is not repaired, then go to next step.</li> </ul>
		No	Go to next step.
3	<b>CHECK SIGNAL CIRCUIT VOLTAGE WHEN EGR BOOST SENSOR CONNECTOR IS DISCONNECTED</b> <ul style="list-style-type: none"> <li>Disconnect EGR boost sensor connector.</li> <li>Turn ignition key to ON (Engine OFF).</li> <li>Measure voltage between EGR boost sensor connector terminal A (harness-side) and body GND.</li> <li>Is voltage <b>above 4.9 V</b>?</li> </ul>	Yes	Go to next step.
		No	Go to Step 5.
4	<b>CHECK POWER SUPPLY CIRCUIT VOLTAGE AT EGR BOOST SENSOR CONNECTOR</b>  <b>Note</b> <ul style="list-style-type: none"> <li>If DTCs P0122 and P0452 are also retrieved with P0107, go to REFERENCE VOLTAGE troubleshooting procedure.</li> </ul> <ul style="list-style-type: none"> <li>Measure voltage between EGR boost sensor terminal C (harness-side) and body ground.</li> <li>Is voltage <b>within 4.5—5.5 V</b>?</li> </ul>	Yes	Check for poor connection of EGR boost sensor terminal C (harness-side). <ul style="list-style-type: none"> <li>Repair or replace terminal as necessary.</li> <li>If okay, replace EGR boost sensor.</li> </ul> Then go to Step 7.
		No	Check for open circuit between PCM terminal 90 (harness-side) and BARO terminal C (harness-side). Repair or replace suspected harness, then go to Step 7.



## ON-BOARD DIAGNOSTIC [ENGINE CONTROL SYSTEM (FS)]

STEP	INSPECTION	ACTION	
5	<b>INSPECT EGR BOOST SENSOR SIGNAL CIRCUIT FOR SHORT TO GROUND</b> <ul style="list-style-type: none"> <li>• Turn ignition key to OFF.</li> <li>• Disconnect PCM connector.</li> <li>• Check for continuity between EGR boost sensor terminal A (harness-side) and body ground.</li> <li>• Is there continuity?</li> </ul>	Yes	Repair or replace suspected harness, then go to next step.
		No	Go to next step.
6	<b>INSPECT EGR BOOST SENSOR SIGNAL AND GROUND CIRCUIT FOR INTERMEDIATE SHORT</b> <ul style="list-style-type: none"> <li>• Check for continuity between EGR boost sensor terminals B and A (harness-side).</li> <li>• Is there continuity?</li> </ul>	Yes	Repair or replace suspected harness, then to go to next step.
		No	Go to next step.
7	<b>VERIFY TROUBLESHOOTING OF DTC P0107 COMPLETED</b> <ul style="list-style-type: none"> <li>• Make sure to reconnect all disconnected connectors.</li> <li>• Turn ignition key to ON (Engine OFF).</li> <li>• Clear DTC from memory using WDS or equivalent.</li> <li>• Start engine.</li> <li>• Is same DTC present?</li> </ul>	Yes	Replace PCM, then go to next step.
		No	No concern is detected. Go to next step.
8	<b>VERIFY AFTER REPAIR PROCEDURE</b> <ul style="list-style-type: none"> <li>• Perform "After Repair Procedure". (See 01-02B-9 AFTER REPAIR PROCEDURE [FS].)</li> <li>• Is there any DTC present?</li> </ul>	Yes	Go to applicable DTC inspection. (See 01-02B-15 DTC TABLE [FS].)
		No	Troubleshooting completed.

01-02B

# ON-BOARD DIAGNOSTIC [ENGINE CONTROL SYSTEM (FS)]

DTC P0108 [FS]

A3U010201084W10

<b>DTC P0108</b>	<b>BARO circuit high input</b>
<b>DETECTION CONDITION</b>	<ul style="list-style-type: none"> <li>PCM monitors input voltage from EGR boost sensor when monitoring conditions are met. If input voltage at PCM terminal 34 is <b>above 4.92 V</b>, PCM determines that EGR boost sensor circuit is malfunctioning.</li> </ul> <p><b>MONITORING CONDITIONS</b></p> <ul style="list-style-type: none"> <li>Intake air temperature is <b>above 10 °C {50 °F}</b>.</li> <li>EGR boost sensor solenoid is turned OFF. (Barometric pressure is applied to EGR boost sensor.)</li> </ul> <p><b>Diagnostic support note</b></p> <ul style="list-style-type: none"> <li>This is a continuous monitor (CCM).</li> <li>MIL illuminates if PCM detects the above malfunction condition during first drive cycle. Therefore, PENDING CODE is not available.</li> <li>FREEZE FRAME DATA is available.</li> <li>DTC is stored in PCM memory.</li> </ul>
	<b>POSSIBLE CAUSE</b>

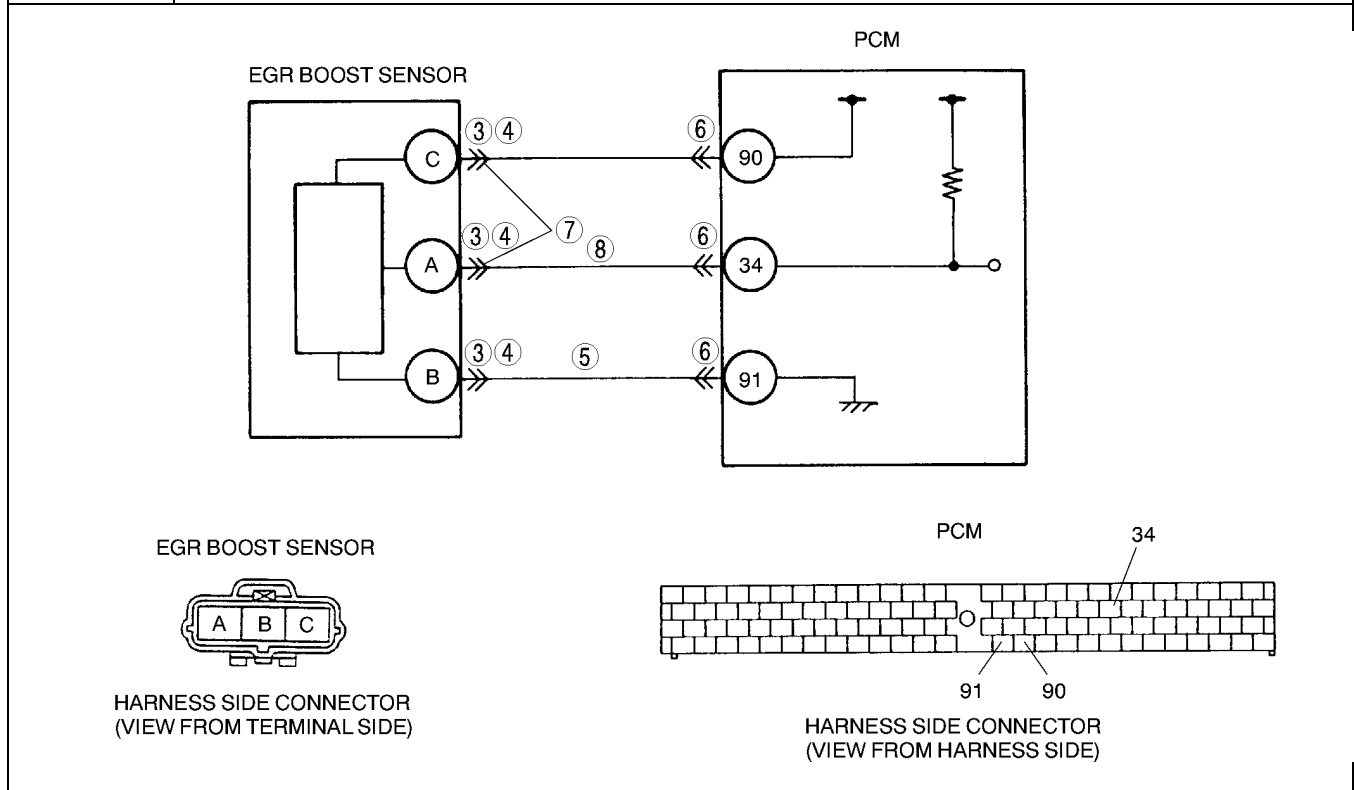

**Diagnostic procedure**

STEP	INSPECTION		ACTION
1	<b>VERIFY FREEZE FRAME DATA HAS BEEN RECORDED</b> <ul style="list-style-type: none"> <li>Has FREEZE FRAME DATA been recorded?</li> </ul>	Yes	Go to next step.
		No	Record FREEZE FRAME DATA on repair order, then go to next step.
2	<b>VERIFY RELATED REPAIR INFORMATION AVAILABILITY</b> <ul style="list-style-type: none"> <li>Check for related Service Bulletins availability.</li> <li>Is any related repair information available?</li> </ul>	Yes	Perform repair or diagnosis according to available repair information. <ul style="list-style-type: none"> <li>If vehicle is not repaired, go to next step.</li> </ul>
		No	Go to next step.
3	<b>INSPECT CONNECTION OF EGR BOOST SENSOR CONNECTOR</b> <ul style="list-style-type: none"> <li>Turn ignition key to OFF.</li> <li>Verify that EGR boost sensor connector is connected securely.</li> <li>Is connection okay?</li> </ul>	Yes	Go to next step.
		No	Reconnect the connector, then go to Step 9.

## ON-BOARD DIAGNOSTIC [ENGINE CONTROL SYSTEM (FS)]

STEP	INSPECTION	ACTION	
4	<b>INSPECT EGR BOOST SENSOR CONNECTOR FOR POOR CONNECTION</b> <ul style="list-style-type: none"> <li>• Disconnect the EGR boost sensor connector.</li> <li>• Check for poor connection (damaged/pulled-out pins, corrosion, etc.).</li> <li>• Is there malfunction?</li> </ul>	Yes	Repair or replace suspected terminal, then go to Step 9.
		No	Go to next step.
5	<b>VERIFY EGR BOOST SENSOR GROUND CIRCUIT FOR OPEN CIRCUIT</b> <ul style="list-style-type: none"> <li>• Check for continuity between EGR boost sensor terminal B (harness-side) and body ground.</li> <li>• Is there continuity?</li> </ul>	Yes	Go to next step.
		No	Check for open circuit between PCM terminal 91 (harness-side) and EGR boost sensor terminal B (harness-side). Repair or replace suspected harness, then go to Step 9.
6	<b>CHECK PCM CONNECTOR</b> <ul style="list-style-type: none"> <li>• Disconnect PCM connector.</li> <li>• Check for poor connection at terminal 91 (damaged/pulled-out pins, corrosion, etc.).</li> <li>• Is there malfunction?</li> </ul>	Yes	Repair terminal, then go to Step 9.
		No	Go to next step.
7	<b>VERIFY EGR BOOST SENSOR SIGNAL CIRCUIT FOR SHORT TO REFERENCE VOLTAGE CIRCUIT</b> <ul style="list-style-type: none"> <li>• Check for continuity between EGR boost sensor terminals A and C (harness-side).</li> <li>• Is there continuity?</li> </ul>	Yes	Repair or replace suspected harness, then go to Step 9.
		No	Go to next step.
8	<b>VERIFY EGR BOOST SENSOR SIGNAL CIRCUIT FOR OPEN CIRCUIT</b> <ul style="list-style-type: none"> <li>• Check for continuity between EGR boost sensor terminal A (harness-side) and PCM terminal 34 (harness-side).</li> <li>• Is there continuity?</li> </ul>	Yes	Go to next step.
		No	Repair or replace suspected harness, then go to next step.
9	<b>VERIFY TROUBLESHOOTING OF DTC P0108 COMPLETED</b> <ul style="list-style-type: none"> <li>• Make sure to reconnect all disconnected connectors.</li> <li>• Turn ignition key to ON (Engine OFF).</li> <li>• Clear DTC from memory using WDS or equivalent.</li> <li>• Start engine.</li> <li>• Is same DTC present?</li> </ul>	Yes	Replace PCM, then go to next step.
		No	No concern is detected. Go to next step.
10	<b>VERIFY AFTER REPAIR PROCEDURE</b> <ul style="list-style-type: none"> <li>• Perform "After Repair Procedure". (See 01-02B-9 AFTER REPAIR PROCEDURE [FS].)</li> <li>• Is there any DTC present?</li> </ul>	Yes	Go to applicable DTC inspection. (See 01-02B-15 DTC TABLE [FS].)
		No	Troubleshooting completed.

01-02B

### DTC P0111 [FS]

A3U010201084W11

DTC P0111	IAT circuit performance problem
<b>DETECTION CONDITION</b>	<ul style="list-style-type: none"> <li>• Intake air temperature is higher than engine coolant temperature by <b>40 °C {72 °F}</b> and ignition key is ON.</li> </ul> <p><b>Diagnostic support note</b></p> <ul style="list-style-type: none"> <li>• This is a continuous monitor (CCM).</li> <li>• MIL illuminates if PCM detects the above malfunction condition in two consecutive drive cycles.</li> <li>• PENDING CODE is available if PCM detects the above malfunction condition during first drive cycle.</li> <li>• FREEZE FRAME DATA is available.</li> <li>• DTC is stored in PCM memory.</li> </ul>
<b>POSSIBLE CAUSE</b>	<ul style="list-style-type: none"> <li>• IAT sensor malfunction</li> <li>• Poor connection at IAT sensor or PCM connector</li> <li>• PCM malfunction</li> </ul>

## ON-BOARD DIAGNOSTIC [ENGINE CONTROL SYSTEM (FS)]

### Diagnostic procedure

STEP	INSPECTION	ACTION	
1	<b>VERIFY FREEZE FRAME DATA HAS BEEN RECORDED</b> <ul style="list-style-type: none"> <li>Has FREEZE FRAME DATA been recorded?</li> </ul>	Yes	Go to next step.
		No	Record FREEZE FRAME DATA on repair order, then go to next step.
2	<b>VERIFY RELATED REPAIR INFORMATION AVAILABILITY</b> <ul style="list-style-type: none"> <li>Check for related Service Bulletins availability.</li> <li>Is any related repair information available?</li> </ul>	Yes	Perform repair or diagnosis according to available repair information. <ul style="list-style-type: none"> <li>If vehicle is not repaired, go to next step.</li> </ul>
		No	Go to next step.
3	<b>INSPECT IAT SENSOR CONNECTOR FOR POOR CONNECTION</b> <ul style="list-style-type: none"> <li>Turn ignition key to OFF.</li> <li>Disconnect IAT sensor connector.</li> <li>Check for poor connection (damaged/pulled-out pins, corrosion, etc.).</li> <li>Is there malfunction?</li> </ul>	Yes	Repair or replace terminal, then go to Step 6.
		No	Go to next step.
4	<b>INSPECT IAT SENSOR</b> <ul style="list-style-type: none"> <li>Measure resistance between IAT sensor terminals A and B (part-side).</li> <li>Is resistance <b>below 550 ohms</b>?</li> </ul>	Yes	Replace IAT sensor, then go to Step 6.
		No	Go to next step.
5	<b>INSPECT PCM CONNECTOR FOR POOR CONNECTION</b> <ul style="list-style-type: none"> <li>Disconnect PCM connector.</li> <li>Check for poor connection at terminals 39 and 91 (damaged/pulled-out pins, corrosion, etc.).</li> <li>Is there malfunction?</li> </ul>	Yes	Repair or replace terminal, then go to Step 6.
		No	Go to next step.
6	<b>VERIFY TROUBLESHOOTING OF DTC P0111 COMPLETED</b> <ul style="list-style-type: none"> <li>Make sure to reconnect all disconnected connectors.</li> <li>Clear DTC from PCM memory using WDS or equivalent.</li> <li>Start engine and run engine under FREEZE FRAME DATA condition.</li> <li>Is PENDING CODE of same DTC present?</li> </ul>	Yes	Replace PCM, then go to next step.
		No	Go to next step.
7	<b>VERIFY AFTER REPAIR PROCEDURE</b> <ul style="list-style-type: none"> <li>Perform "After Repair Procedure". (See 01-02B-9 AFTER REPAIR PROCEDURE [FS].)</li> <li>Is there any DTC present?</li> </ul>	Yes	Go to applicable DTC inspection. (See 01-02B-15 DTC TABLE [FS].)
		No	Troubleshooting completed.

### DTC P0112 [FS]

A3U010201084W12

DTC P0112	IAT circuit low input
<b>DETECTION CONDITION</b>	<ul style="list-style-type: none"> <li>PCM monitors IAT sensor signal at PCM terminal 39. If voltage at PCM terminal 39 is <b>below 0.16 V</b>, PCM determines that IAT sensor circuit has malfunction.</li> </ul> <p><b>Diagnostic support note</b></p> <ul style="list-style-type: none"> <li>This is a continuous monitor (CCM).</li> <li>MIL illuminates if PCM detects the above malfunction condition during first drive cycle. Therefore, PENDING CODE is not available.</li> <li>FREEZE FRAME DATA is available.</li> <li>DTC is stored in PCM memory.</li> </ul>
<b>POSSIBLE CAUSE</b>	<ul style="list-style-type: none"> <li>IAT sensor malfunction</li> <li>Short to ground circuit between IAT sensor terminal A and PCM terminal 39</li> <li>IAT signal and IAT ground circuits are shorted each other.</li> <li>PCM malfunction</li> </ul>

# ON-BOARD DIAGNOSTIC [ENGINE CONTROL SYSTEM (FS)]

01-02B

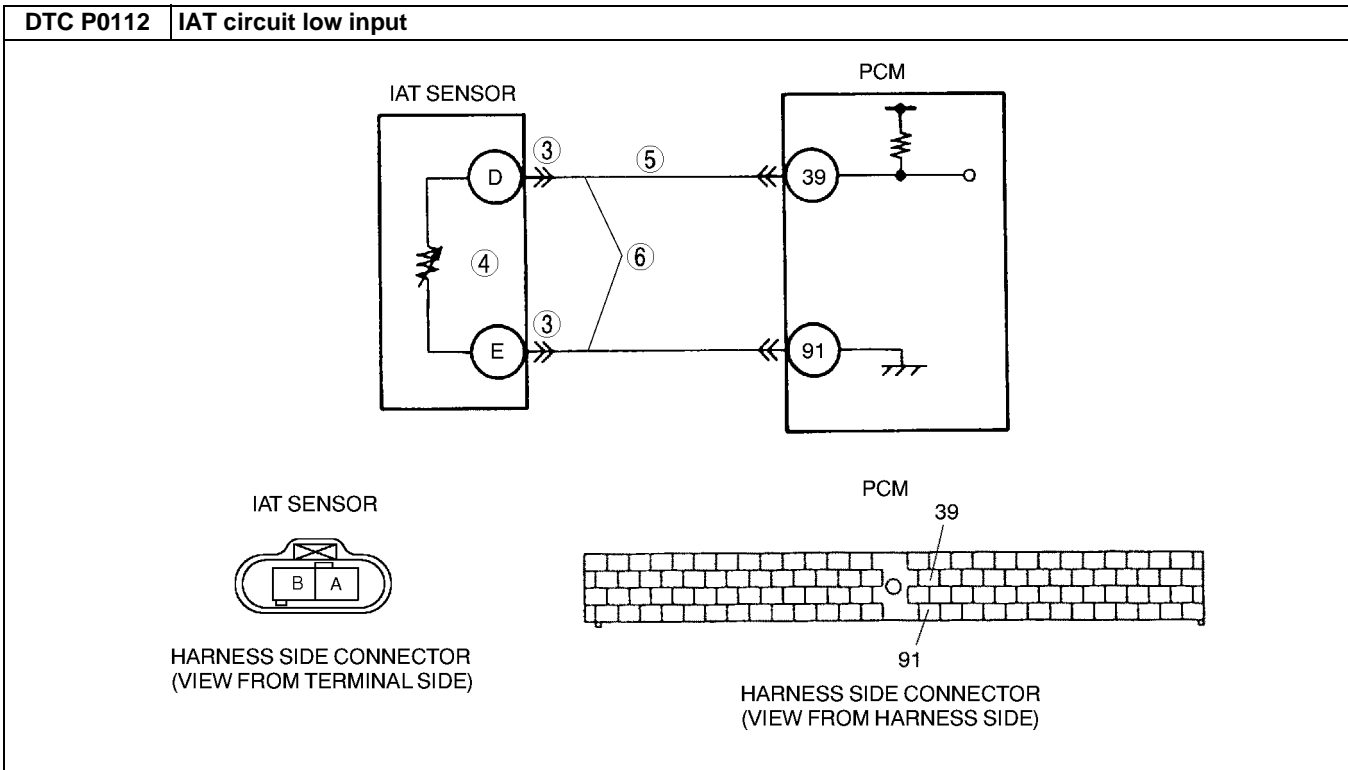

**Diagnostic procedure**

STEP	INSPECTION		ACTION
1	<b>VERIFY FREEZE FRAME DATA HAS BEEN RECORDED</b> <ul style="list-style-type: none"> <li>Has FREEZE FRAME DATA been recorded?</li> </ul>	Yes	Go to next step.
		No	Record FREEZE FRAME DATA on repair order, then go to next step.
2	<b>VERIFY RELATED REPAIR INFORMATION AVAILABILITY</b> <ul style="list-style-type: none"> <li>Check for related Service Bulletins availability.</li> <li>Is any related repair information available?</li> </ul>	Yes	Perform repair or diagnosis according to available repair information. <ul style="list-style-type: none"> <li>If vehicle is not repaired, then go to next step.</li> </ul>
		No	Go to next step.
3	<b>INSPECT IAT SENSOR TERMINALS</b> <ul style="list-style-type: none"> <li>Turn ignition key to OFF.</li> <li>Disconnect IAT sensor connector.</li> <li>Check for bent terminals of IAT sensor terminals A and B (part-side).</li> <li>Is there malfunction?</li> </ul>	Yes	Repair or replace terminal, then go to Step 7.
		No	Go to next step.
4	<b>CLASSIFY IAT SENSOR MALFUNCTION OR HARNESS MALFUNCTION</b> <ul style="list-style-type: none"> <li>Disconnect IAT sensor connector.</li> <li>Measure resistance between IAT sensor terminals A and B (part-side).</li> <li>Is resistance <b>within 0.117—28.616 kilohms</b>?</li> </ul>	Yes	Go to next step.
		No	Replace IAT sensor, then go to Step 7.
5	<b>INSPECT IAT SIGNAL CIRCUIT FOR SHORT TO GROUND</b> <ul style="list-style-type: none"> <li>Turn ignition key to OFF.</li> <li>Disconnect PCM connector.</li> <li>Check for continuity between IAT sensor terminal A (harness-side) and body ground.</li> <li>Is there continuity?</li> </ul>	Yes	Repair or replace harness for short to ground, then go to Step 7.
		No	Go to next step.
6	<b>INSPECT IAT CIRCUITS FOR INTERMEDIATE SHORT</b> <ul style="list-style-type: none"> <li>Check for continuity between IAT sensor terminals A and B (harness-side).</li> <li>Is there continuity?</li> </ul>	Yes	Repair or replace harness for short, then go to Step 8.
		No	Go to next step.

## ON-BOARD DIAGNOSTIC [ENGINE CONTROL SYSTEM (FS)]

STEP	INSPECTION		ACTION
7	<b>VERIFY TROUBLESHOOTING OF DTC P0112 COMPLETED</b> <ul style="list-style-type: none"> <li>Make sure to reconnect all disconnected connectors.</li> <li>Clear DTC from PCM memory using WDS or equivalent.</li> <li>Start engine.</li> <li>Is same DTC present?</li> </ul>	Yes	Replace PCM, then go to next step.
		No	No concern is detected. Go to next step.
8	<b>VERIFY AFTER REPAIR PROCEDURE</b> <ul style="list-style-type: none"> <li>Perform "After Repair Procedure". (See 01-02B-9 AFTER REPAIR PROCEDURE [FS].)</li> <li>Is there any DTC present?</li> </ul>	Yes	Go to applicable DTC inspection. (See 01-02B-15 DTC TABLE [FS].)
		No	Troubleshooting completed.

### DTC P0113 [FS]

A3U010201084W13

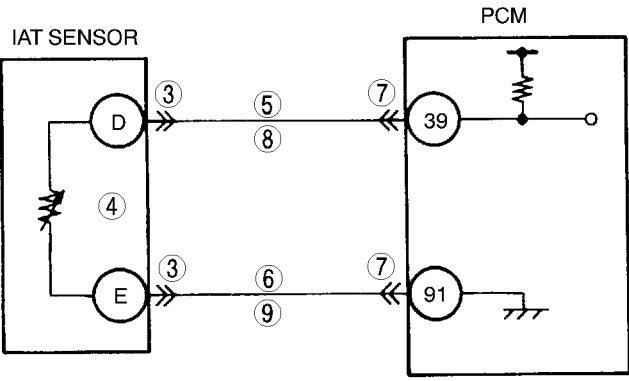
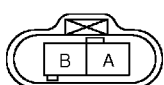
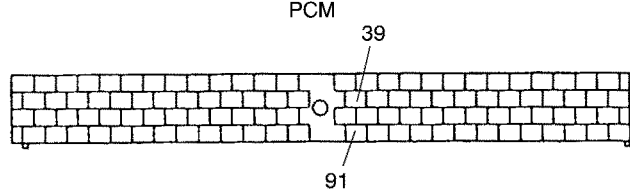
DTC P0113	IAT circuit high input
<b>DETECTION CONDITION</b>	<ul style="list-style-type: none"> <li>The PCM monitors IAT sensor signal at PCM terminal 39. If voltage at PCM terminal 39 is <b>above 4.84 V</b>, PCM determines that IAT sensor circuit has malfunction.</li> </ul> <p><b>Diagnostic support note</b></p> <ul style="list-style-type: none"> <li>This is a continuous monitor (CCM).</li> <li>MIL illuminates if PCM detects the above malfunction condition during first drive cycle. Therefore, PENDING CODE is not available.</li> <li>FREEZE FRAME DATA is available.</li> <li>DTC is not stored in PCM memory.</li> </ul>
<b>POSSIBLE CAUSE</b>	<ul style="list-style-type: none"> <li>IAT sensor malfunction</li> <li>Open circuit between IAT sensor terminal A and PCM terminal 39</li> <li>Short to power circuit between IAT sensor terminal A and PCM terminal 39</li> <li>Open circuit between IAT sensor terminal B and PCM terminal 91</li> <li>Short to power circuit between IAT sensor terminal B and PCM terminal 91</li> <li>Poor connection at IAT sensor or PCM connector</li> <li>PCM malfunction</li> </ul>
	
 <p style="text-align: center;">IAT SENSOR HARNESS SIDE CONNECTOR (VIEW FROM TERMINAL SIDE)</p>	 <p style="text-align: center;">PCM HARNESS SIDE CONNECTOR (VIEW FROM HARNESS SIDE)</p>

# ON-BOARD DIAGNOSTIC [ENGINE CONTROL SYSTEM (FS)]

## Diagnostic procedure

STEP	INSPECTION	ACTION	
1	<b>VERIFY FREEZE FRAME DATA HAS BEEN RECORDED</b> <ul style="list-style-type: none"> <li>Has FREEZE FRAME DATA been recorded?</li> </ul>	Yes	Go to next step.
		No	Record FREEZE FRAME DATA on repair order, then go to next step.
2	<b>VERIFY RELATED REPAIR INFORMATION AVAILABILITY</b> <ul style="list-style-type: none"> <li>Check for related Service Bulletins availability.</li> <li>Is any related repair information available?</li> </ul>	Yes	Perform repair or diagnosis according to available repair information. <ul style="list-style-type: none"> <li>If vehicle is not repaired, go to next step.</li> </ul>
		No	Go to next step.
3	<b>INSPECT IAT SENSOR CONNECTOR FOR POOR CONNECTION</b> <ul style="list-style-type: none"> <li>Turn ignition key to OFF.</li> <li>Disconnect IAT sensor connector.</li> <li>Check for poor connection (damaged/pulled-out pins, corrosion, etc.).</li> <li>Is there malfunction?</li> </ul>	Yes	Repair or replace terminal, then go to Step 10.
		No	Go to next step.
4	<b>INSPECT IAT SENSOR</b> <ul style="list-style-type: none"> <li>Disconnect IAT sensor connector.</li> <li>Measure resistance between IAT sensor terminals A and B (part-side).</li> <li>Is resistance <b>within 0.117—28.616 kilohms</b>?</li> </ul>	Yes	Replace IAT sensor, then go to Step 10.
		No	Go to next step.
5	<b>INSPECT IAT SENSOR SIGNAL CIRCUIT FOR SHORT TO POWER</b> <ul style="list-style-type: none"> <li>Turn ignition key to ON (Engine OFF).</li> <li>Measure voltage between IAT sensor terminal B (harness-side) and body ground.</li> <li>Is there voltage <b>B+</b>?</li> </ul>	Yes	Repair or replace harness for short to power, then go to Step 10.
		No	Go to next step.
6	<b>INSPECT IAT SENSOR GROUND CIRCUIT FOR SHORT TO POWER</b> <ul style="list-style-type: none"> <li>Measure voltage between IAT sensor terminal A (harness-side) and body ground.</li> <li>Is voltage <b>B+</b>?</li> </ul>	Yes	Repair or replace harness for short to power, then go to Step 10.
		No	Go to next step.
7	<b>INSPECT PCM CONNECTOR POOR CONNECTION</b> <ul style="list-style-type: none"> <li>Turn ignition key to OFF.</li> <li>Disconnect PCM connector.</li> <li>Inspect PCM terminal 39 and 91 (harness-side) for tightness using feeler tool.</li> <li>Is there malfunction?</li> </ul>	Yes	Repair or replace terminal, then go to Step 10.
		No	Go to next step.
8	<b>INSPECT IAT SENSOR SIGNAL CIRCUIT FOR OPEN CIRCUIT</b> <ul style="list-style-type: none"> <li>Connect breakout box with PCM disconnected.</li> <li>Check for continuity between IAT sensor terminal A (harness-side) and breakout box terminal 39.</li> <li>Is there continuity?</li> </ul>	Yes	Go to next step.
		No	Repair or replace harness for open, then go to Step 10.
9	<b>INSPECT IAT SENSOR GROUND CIRCUIT FOR OPEN CIRCUIT</b> <ul style="list-style-type: none"> <li>Check for continuity between IAT sensor terminal B (harness-side) and breakout box terminal 91.</li> <li>Is there continuity?</li> </ul>	Yes	Go to next step.
		No	Repair or replace harness for open, then go to next step.
10	<b>VERIFY TROUBLESHOOTING OF DTC P0113 COMPLETED</b> <ul style="list-style-type: none"> <li>Make sure to reconnect all disconnected connectors.</li> <li>Clear DTC from PCM memory using WDS or equivalent.</li> <li>Start engine.</li> <li>Is same DTC present?</li> </ul>	Yes	Replace PCM, then go to next step.
		No	No concern is detected. Go to next step.
11	<b>VERIFY AFTER REPAIR PROCEDURE</b> <ul style="list-style-type: none"> <li>Perform "After Repair Procedure". (See 01-02B-9 AFTER REPAIR PROCEDURE [FS].)</li> <li>Is there any DTC present?</li> </ul>	Yes	Go to applicable DTC inspection. (See 01-02B-15 DTC TABLE [FS].)
		No	Troubleshooting completed.

01-02B

# ON-BOARD DIAGNOSTIC [ENGINE CONTROL SYSTEM (FS)]

DTC P0117 [FS]

A3U010201084W14

<b>DTC P0117</b>	<b>ECT circuit low input</b>
<b>DETECTION CONDITION</b>	<ul style="list-style-type: none"> <li>PCM monitors ECT sensor signal at PCM terminal 38. If voltage at terminal 38 is <b>below 0.20 V</b>, PCM determines that ECT sensor circuit has malfunction.</li> </ul> <p><b>Diagnostic support note</b></p> <ul style="list-style-type: none"> <li>This is a continuous monitor (CCM).</li> <li>MIL illuminates if PCM detects the above malfunction condition during first drive cycle. Therefore, PENDING CODE is not available.</li> <li>FREEZE FRAME DATA is available.</li> <li>DTC is stored in PCM memory.</li> </ul>
	<b>POSSIBLE CAUSE</b>

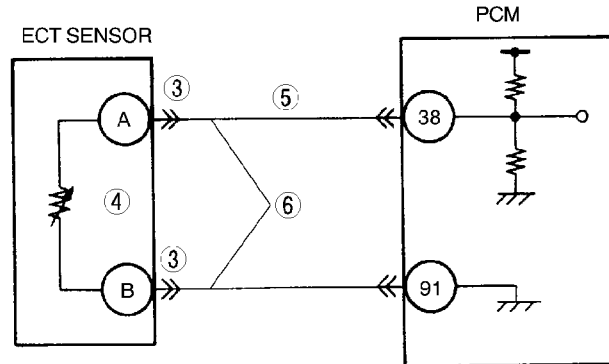

ECT SENSOR

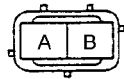

HARNES SIDE CONNECTOR  
(VIEW FROM TERMINAL SIDE)

PCM

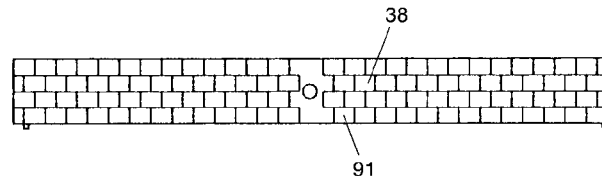

HARNES SIDE CONNECTOR  
(VIEW FROM HARNES SIDE)

**Diagnostic procedure**

STEP	INSPECTION		ACTION
1	<b>VERIFY FREEZE FRAME DATA HAS BEEN RECORDED</b> <ul style="list-style-type: none"> <li>Has FREEZE FRAME DATA been recorded?</li> </ul>	Yes	Go to next step.
		No	Record FREEZE FRAME DATA on repair order, then go to next step.
2	<b>VERIFY RELATED REPAIR INFORMATION AVAILABILITY</b> <ul style="list-style-type: none"> <li>Check for related Service Bulletins availability.</li> <li>Is any related repair information available?</li> </ul>	Yes	Perform repair or diagnosis according to available repair information. <ul style="list-style-type: none"> <li>If vehicle is not repaired, go to next step.</li> </ul>
		No	Go to next step.
3	<b>INSPECT ECT SENSOR TERMINAL BENT</b> <ul style="list-style-type: none"> <li>Turn ignition key to OFF.</li> <li>Disconnect ECT sensor connector.</li> <li>Check for bent of ECT sensor terminals A and B (part-side).</li> <li>Is there malfunction?</li> </ul>	Yes	Repair or replace terminal, then go to Step 7.
		No	Go to next step.
4	<b>CLASSIFY ECT SENSOR MALFUNCTION OR HARNES MALFUNCTION</b> <ul style="list-style-type: none"> <li>Measure resistance between ECT sensor terminals A and B (part-side).</li> <li>Is resistance <b>within 0.111—25.403 kilohms</b>?</li> </ul>	Yes	Go to next step.
		No	Replace ECT sensor, then go to Step 7.



## ON-BOARD DIAGNOSTIC [ENGINE CONTROL SYSTEM (FS)]

STEP	INSPECTION	ACTION	
5	<b>INSPECT ECT SIGNAL CIRCUIT FOR SHORT TO GROUND</b> <ul style="list-style-type: none"> <li>• Turn ignition key to OFF.</li> <li>• Disconnect PCM connector.</li> <li>• Check for continuity between ECT sensor terminal A (harness-side) and body ground.</li> <li>• Is there continuity?</li> </ul>	Yes	Repair or replace harness for short to ground, then go to Step 7.
		No	Go to next step.
6	<b>INSPECT ECT CIRCUIT FOR SHORT</b> <ul style="list-style-type: none"> <li>• Check for continuity between ECT sensor terminals A and B (harness-side).</li> <li>• Is there continuity?</li> </ul>	Yes	Repair or replace harness for short, then go to next step.
		No	Go to next step.
7	<b>VERIFY TROUBLESHOOTING OF DTC P0117 COMPLETED</b> <ul style="list-style-type: none"> <li>• Make sure to reconnect all disconnected connectors.</li> <li>• Clear DTC from PCM memory using WDS or equivalent.</li> <li>• Start engine.</li> <li>• Is same DTC present?</li> </ul>	Yes	Replace PCM, then go to next step.
		No	Go to next step.
8	<b>VERIFY AFTER REPAIR PROCEDURE</b> <ul style="list-style-type: none"> <li>• Perform "After Repair Procedure". (See 01-02B-9 AFTER REPAIR PROCEDURE [FS].)</li> <li>• Is there any DTC present?</li> </ul>	Yes	Go to applicable DTC inspection. (See 01-02B-15 DTC TABLE [FS].)
		No	Troubleshooting completed.

01-02B

# ON-BOARD DIAGNOSTIC [ENGINE CONTROL SYSTEM (FS)]

DTC P0118 [FS]

A3U010201084W15

<b>DTC P0118</b>	<b>ECT circuit high input</b>
<b>DETECTION CONDITION</b>	<ul style="list-style-type: none"> <li>PCM monitors ECT sensor signal at PCM terminal 38. If voltage at terminal 38 is <b>above 4.94 V</b>, PCM determines that ECT sensor circuit has malfunction.</li> </ul> <p><b>Diagnostic support note</b></p> <ul style="list-style-type: none"> <li>This is a continuous monitor (CCM).</li> <li>MIL illuminates if PCM detects the above malfunction condition during first drive cycle. Therefore, PENDING CODE is not available.</li> <li>FREEZE FRAME DATA is available.</li> <li>DTC is stored in PCM memory.</li> </ul>
	<p><b>POSSIBLE CAUSE</b></p> <ul style="list-style-type: none"> <li>ECT sensor malfunction</li> <li>Open circuit between ECT sensor terminal A and PCM terminal 38</li> <li>Short to power circuit between ECT sensor terminal A and PCM terminal 38</li> <li>Open circuit between ECT sensor terminal B and PCM terminal 91</li> <li>Poor connection of ECT sensor or PCM connectors</li> <li>PCM malfunction</li> </ul>

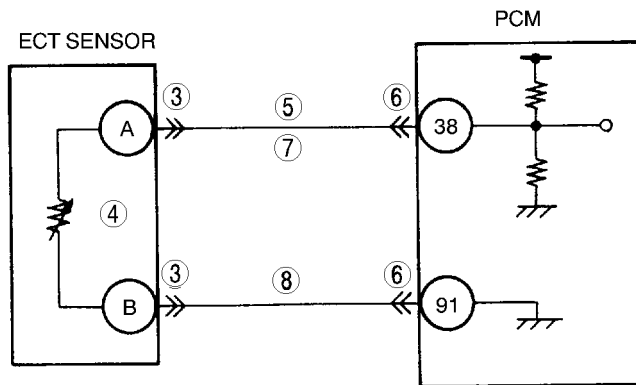

ECT SENSOR

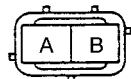

HARNESS SIDE CONNECTOR  
(VIEW FROM TERMINAL SIDE)

PCM

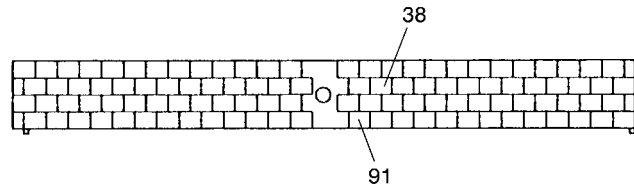

HARNESS SIDE CONNECTOR  
(VIEW FROM HARNESS SIDE)

**Diagnostic procedure**

STEP	INSPECTION		ACTION
1	<b>VERIFY FREEZE FRAME DATA HAS BEEN RECORDED</b> <ul style="list-style-type: none"> <li>Has FREEZE FRAME DATA been recorded?</li> </ul>	Yes	Go to next step.
		No	Record FREEZE FRAME DATA on repair order, then go to next step.
2	<b>VERIFY RELATED REPAIR INFORMATION AVAILABILITY</b> <ul style="list-style-type: none"> <li>Check for related Service Bulletins availability.</li> <li>Is any related repair information available?</li> </ul>	Yes	Perform repair or diagnosis according to available repair information. <ul style="list-style-type: none"> <li>If vehicle is not repaired, go to next step.</li> </ul>
		No	Go to next step.
3	<b>INSPECT ECT SENSOR CONNECTOR FOR POOR CONNECTION</b> <ul style="list-style-type: none"> <li>Turn ignition key to OFF.</li> <li>Disconnect ECT sensor connector.</li> <li>Check for poor connection (damaged/pulled-out pins, corrosion, etc.).</li> <li>Is there malfunction?</li> </ul>	Yes	Repair or replace terminal, then go to Step 9.
		No	Go to next step.

## ON-BOARD DIAGNOSTIC [ENGINE CONTROL SYSTEM (FS)]

STEP	INSPECTION	ACTION
4	<b>CLASSIFY ECT SENSOR OR HARNESS MALFUNCTION</b> <ul style="list-style-type: none"> <li>Measure resistance between ECT sensor terminals A and B (part-side).</li> <li>Is resistance <b>within 0.111—25.403 kilohms</b>?</li> </ul>	Yes Replace ECT sensor, then go to Step 9.
		No Go to next step.
5	<b>INSPECT ECT SENSOR SIGNAL CIRCUIT FOR SHORT TO POWER</b> <ul style="list-style-type: none"> <li>Turn ignition key to ON (Engine OFF).</li> <li>Measure voltage between ECT sensor terminal A (harness-side) and body ground.</li> <li>Is there voltage <b>B+</b>?</li> </ul>	Yes Repair or replace harness for short to power, then go to Step 9.
		No Go to next step.
6	<b>INSPECT PCM CONNECTOR FOR POOR CONNECTION</b> <ul style="list-style-type: none"> <li>Disconnect PCM connector.</li> <li>Check for poor connection at terminals 38 and 91 (damaged/pulled-out pins, corrosion, etc.).</li> <li>Is there malfunction?</li> </ul>	Yes Repair or replace terminal, then go to Step 9.
		No Go to next step.
7	<b>INSPECT ECT SENSOR SIGNAL CIRCUIT FOR OPEN CIRCUIT</b> <ul style="list-style-type: none"> <li>Connect breakout box with PCM disconnected.</li> <li>Check for continuity between ECT sensor terminal A (harness-side) and breakout box terminal 38.</li> <li>Is there continuity?</li> </ul>	Yes Go to next step.
		No Repair or replace harness for open, then go to Step 9.
8	<b>INSPECT ECT SENSOR GROUND CIRCUIT FOR OPEN CIRCUIT</b> <ul style="list-style-type: none"> <li>Check for continuity between ECT sensor terminal B (harness-side) and breakout box terminal 91.</li> <li>Is there continuity?</li> </ul>	Yes Go to next step.
		No Repair or replace harness for open, then go to next step.
9	<b>VERIFY TROUBLESHOOTING OF DTC P0118 COMPLETED</b> <ul style="list-style-type: none"> <li>Make sure to reconnect all disconnected connectors.</li> <li>Clear DTC from PCM memory using WDS or equivalent.</li> <li>Start engine.</li> <li>Is same DTC present?</li> </ul>	Yes Replace PCM, then go to next step.
		No Go to next step.
10	<b>VERIFY AFTER REPAIR PROCEDURE</b> <ul style="list-style-type: none"> <li>Perform "After Repair Procedure". (See 01-02B-9 AFTER REPAIR PROCEDURE [FS].)</li> <li>Is there any DTC present?</li> </ul>	Yes Go to applicable DTC inspection. (See 01-02B-15 DTC TABLE [FS].)
		No Troubleshooting completed.

01-02B

### DTC P0121 [FS]

A3U010201084W16

DTC P0121	TP circuit range/performance problem
<b>DETECTION CONDITION</b>	<ul style="list-style-type: none"> <li>If PCM detects that throttle valve opening angle is <b>below 12.5%</b> for <b>5 seconds</b> after following conditions are met, PCM determines that TP is stuck closed:                             <b>MONITORING CONDITIONS</b> <ul style="list-style-type: none"> <li>Engine coolant temperature is <b>above 70 °C {158 °F}</b>.</li> <li>MAF sensor signal is <b>above 73.4 g/s {9.7 lb/min}</b>.</li> </ul> </li> <li>If PCM detects that throttle valve opening angle is <b>above 50%</b> for <b>5 seconds</b> after following conditions are met, PCM determines that TP is stuck open:                             <b>MONITORING CONDITIONS</b> <ul style="list-style-type: none"> <li>Engine speed is <b>above 500 rpm</b>.</li> <li>MAF sensor signal is <b>below 5 g/s {0.66 lb/min}</b>.</li> </ul> </li> </ul> <b>Diagnostic support note</b> <ul style="list-style-type: none"> <li>This is a continuous monitor (CCM).</li> <li>MIL illuminates if PCM detects the above malfunction conditions in two consecutive drive cycles.</li> <li>PENDING CODE is available if PCM detects the above malfunction condition during first drive cycle.</li> <li>FREEZE FRAME DATA is available.</li> <li>DTC is stored in PCM memory.</li> </ul>

## ON-BOARD DIAGNOSTIC [ENGINE CONTROL SYSTEM (FS)]

<b>DTC P0121</b>	<b>TP circuit range/performance problem</b>
<b>POSSIBLE CAUSE</b>	<ul style="list-style-type: none"> <li>• TP sensor malfunction</li> <li>• MAF sensor malfunction</li> <li>• Electrical corrosion in TP signal circuit</li> <li>• Voltage drops in reference voltage (vref) supply circuit</li> <li>• Voltage drops in ground circuit</li> <li>• PCM malfunction</li> </ul>

### Diagnostic procedure

STEP	INSPECTION		ACTION
1	<b>VERIFY FREEZE FRAME DATA HAS BEEN RECORDED</b> <ul style="list-style-type: none"> <li>• Has FREEZE FRAME DATA been recorded?</li> </ul>	Yes	Go to next step.
		No	Record FREEZE FRAME DATA on repair order, then go to next step.
2	<b>VERIFY RELATED PENDING CODE OR STORED DTC</b> <ul style="list-style-type: none"> <li>• Turn ignition key to ON (Engine OFF).</li> <li>• Retrieve pending or stored DTCs using WDS or equivalent.</li> <li>• Is DTC P0101 also retrieved?</li> </ul>	Yes	Go to DTC P0101 troubleshooting procedure.
		No	Go to next step.
3	<b>VERIFY RELATED REPAIR INFORMATION AVAILABILITY</b> <ul style="list-style-type: none"> <li>• Check for related Service Bulletins availability.</li> <li>• Is any related repair information available?</li> </ul>	Yes	Perform repair or diagnosis according to available repair information. <ul style="list-style-type: none"> <li>• If vehicle is not repaired, go to next step.</li> </ul>
		No	Go to next step.
4	<b>VERIFY CURRENT INPUT SIGNAL STATUS - IS CONCERN INTERMITTENT OR CONSTANT</b> <ul style="list-style-type: none"> <li>• Start the engine.</li> <li>• Access ECT, TP and MAF PIDs using WDS or equivalent.</li> <li>• Warm up the engine until ECT PID is <b>above 70 °C {158 °F}</b>.</li> <li>• Drive the vehicle.</li> <li>• Read TP PID while MAF PID is <b>above 73.4 g/s {9.7 lb/min}</b>.</li> <li>• Is TP PID reading <b>above 12.5%</b>?</li> </ul>	Yes	Go to next step.
		No	Intermittent concern exists. Go to INTERMITTENT CONCERN TROUBLESHOOTING procedure. (See 01-03B-4 INTERMITTENT CONCERN TROUBLESHOOTING [FS].)
5	<b>VERIFY TP PID</b> <ul style="list-style-type: none"> <li>• Clear DTC from PCM memory using WDS or equivalent.</li> <li>• Start engine.</li> <li>• Access TP, MAF and RPM PIDs using WDS or equivalent.</li> <li>• Read TP PID while MAF PID is <b>below 4.8g/s {0.6 lb/min}</b> and RPM PID is <b>above 500 rpm</b>.</li> <li>• Is TP PID reading <b>above 50%</b>?</li> </ul>	Yes	Go to Step 7.
		No	Go to next step.
6	<b>VERIFY CURRENT INPUT SIGNAL STATUS - IS CONCERN INTERMITTENT OR CONSTANT</b> <ul style="list-style-type: none"> <li>• Drive the vehicle and read MAF PID.</li> <li>• Does MAF PID change in compliance with driving condition?</li> </ul>	Yes	Intermittent concern exists. Go to INTERMITTENT CONCERN TROUBLESHOOTING procedure. (See 01-03B-4 INTERMITTENT CONCERN TROUBLESHOOTING [FS].)
		No	Check MAF sensor and related circuits and terminals. (See 01-40B-28 MASS AIR FLOW (MAF) SENSOR INSPECTION [FS].) Repair or replace as necessary, then go to Step 11.
7	<b>CHECK TP SENSOR TERMINALS FOR ELECTRICAL CORROSION</b> <ul style="list-style-type: none"> <li>• Turn ignition key to OFF.</li> <li>• Disconnect TP sensor connector.</li> <li>• Check for electrical corrosion on male and female TP sensor terminals.</li> <li>• Is any electrical corrosion found?</li> </ul>	Yes	Repair or replace suspected terminal or TP sensor, then go to Step 11.
		No	Go to next step.
8	<b>CHECK GROUND CIRCUIT FOR VOLTAGE DROP</b> <ul style="list-style-type: none"> <li>• Check resistance between TP sensor terminal B (harness-side) and body ground.</li> <li>• Does resistance read <b>approx. 0 ohm</b>?</li> </ul>	Yes	Go to next step.
		No	Repair or replace rusted or corroded PCM terminal 91 (harness-side). Disconnect breakout box and go to Step 11.
9	<b>VERIFY TP SENSOR</b> <ul style="list-style-type: none"> <li>• Does TP sensor resistance smoothly change while gradually opening throttle valve?</li> </ul>	Yes	Go to next step.
		No	Replace TP sensor, then go to Step 11.

## ON-BOARD DIAGNOSTIC [ENGINE CONTROL SYSTEM (FS)]

STEP	INSPECTION	ACTION	
10	<b>CHECK PCM TERMINALS FOR ELECTRICAL CORROSION</b> <ul style="list-style-type: none"> <li>• Disconnect PCM connector.</li> <li>• Check for electrical corrosion on PCM male and female terminals at 89, 90 and 91.</li> <li>• Is any electrical corrosion found?</li> </ul>	Yes	Repair terminal, then go to next step.
		No	Go to next step.
11	<b>VERIFY TROUBLESHOOTING OF DTC P0121 COMPLETED</b> <ul style="list-style-type: none"> <li>• Make sure to reconnect all disconnected connectors.</li> <li>• Start the engine.</li> <li>• Clear DTC from PCM memory using WDS or equivalent.</li> <li>• Access RPM, ECT, TP and MAF PIDs using WDS or equivalent.</li> <li>• Verify TP PID is reading <b>below 50%</b> while MAF PID is <b>below 5 g/s {0.66 lb/min}</b> and RPM PID is <b>above 500 rpm</b>.</li> <li>• Warm up the engine until ECT PID is reading <b>above 70 °C {158°F}</b>.</li> <li>• Drive the vehicle and read TP and MAF PIDs.</li> <li>• Verify PID readings are within specifications MAF PID: <b>above 73.4 g/s {9.7 lb/min}</b> TP PID: <b>above 12.5% more than 5 seconds</b></li> <li>• Is pending code of same DTC present?</li> </ul>	Yes	Replace PCM, then go to next step.
		No	Go to next step.
12	<b>VERIFY AFTER REPAIR PROCEDURE</b> <ul style="list-style-type: none"> <li>• Perform "After Repair Procedure". (See 01-02B-9 AFTER REPAIR PROCEDURE [FS].)</li> <li>• Is there any DTC present?</li> </ul>	Yes	Go to applicable DTC inspection. (See 01-02B-15 DTC TABLE [FS].)
		No	Troubleshooting completed.

01-02B

# ON-BOARD DIAGNOSTIC [ENGINE CONTROL SYSTEM (FS)]

DTC P0122 [FS]

A3U010201084W17

<b>DTC P0122</b>	<b>TP circuit low input</b>
<b>DETECTION CONDITION</b>	<ul style="list-style-type: none"> <li>If PCM detects TP sensor voltage at PCM terminal 89 <b>below 0.10 V</b> after engine start, PCM determines that TP circuit has a malfunction.</li> </ul> <p><b>Diagnostic support note</b></p> <ul style="list-style-type: none"> <li>This is a continuous monitor (CCM).</li> <li>MIL illuminates if PCM detects the above malfunction conditions during first drive cycle. Therefore, PENDING CODE is not available.</li> <li>FREEZE FRAME DATA is available.</li> <li>DTC is stored in PCM memory.</li> </ul>
	<p><b>POSSIBLE CAUSE</b></p> <ul style="list-style-type: none"> <li>TP sensor malfunction</li> <li>Connector or terminal malfunction</li> <li>Open circuit between TP sensor terminal C and PCM terminal 89</li> <li>Short to ground circuit between TP sensor terminal C and PCM terminal 89</li> <li>Open circuit between TP sensor terminal A and PCM terminal 90</li> <li>Short to ground circuit between TP sensor terminal A and PCM terminal 90</li> <li>PCM malfunction</li> </ul>

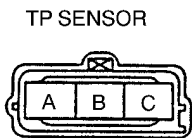
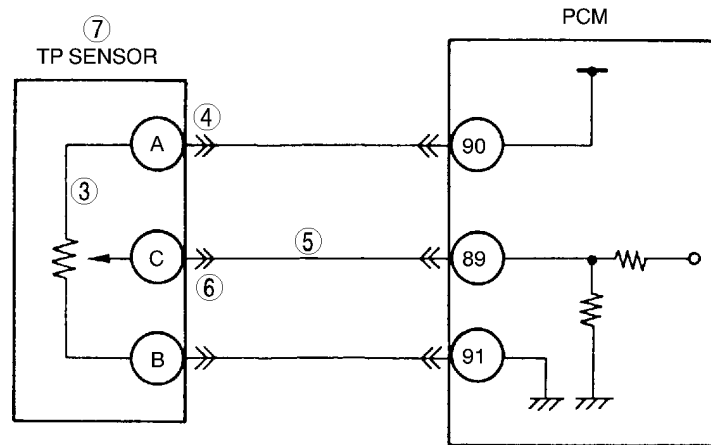

TP SENSOR  
HARNESS SIDE CONNECTOR  
(VIEW FROM TERMINAL SIDE)

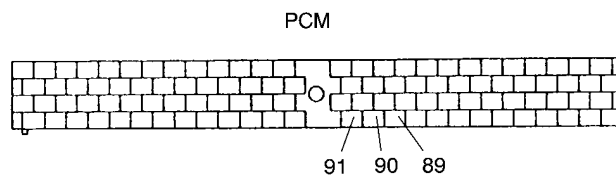

PCM  
HARNESS SIDE CONNECTOR  
(VIEW FROM HARNESS SIDE)

**Diagnostic procedure**

STEP	INSPECTION		ACTION
1	<b>VERIFY FREEZE FRAME DATA HAS BEEN RECORDED</b> <ul style="list-style-type: none"> <li>Has FREEZE FRAME DATA been recorded?</li> </ul>	Yes	Go to next step.
		No	Record FREEZE FRAME DATA on repair order, then go to next step.
2	<b>VERIFY RELATED REPAIR INFORMATION AVAILABILITY</b> <ul style="list-style-type: none"> <li>Check for related Service Bulletins availability.</li> <li>Is any related repair information available?</li> </ul>	Yes	Perform repair or diagnosis according to available repair information. <ul style="list-style-type: none"> <li>If vehicle is not repaired, go to next step.</li> </ul>
		No	Go to next step.
3	<b>CHECK TP SENSOR CIRCUIT FOR OPEN CIRCUIT</b> <ul style="list-style-type: none"> <li>Turn ignition key to OFF.</li> <li>Check for continuity between TP sensor terminals A and C (part-side).</li> <li>Is there continuity?</li> </ul>	Yes	Check TP sensor connector terminal A for poor connection. Repair or replace as necessary, then go to Step 8.
		No	Go to Step 8.

## ON-BOARD DIAGNOSTIC [ENGINE CONTROL SYSTEM (FS)]

01-02B

STEP	INSPECTION		ACTION
4	<b>CHECK POWER SUPPLY CIRCUIT VOLTAGE AT TP SENSOR CONNECTOR</b>  <b>Note</b> <ul style="list-style-type: none"> <li>If DTC P0107 and P0452 are also retrieved with P0122, go to REFERENCE VOLTAGE troubleshooting procedure. (See 01-03B-49 NO.30 REFERENCE VOLTAGE [FS].)</li> <li>Turn ignition key to ON (Engine OFF).</li> <li>Check voltage at TP sensor terminal A (harness-side).</li> <li>Is voltage <b>within 4.5—5.5 V</b>?</li> </ul>	Yes	Go to next step.
		No	Repair or replace open circuit in wiring harness between TP sensor terminal A (harness-side) and PCM terminal 90 (harness-side), then go to Step 8.
5	<b>VERIFY TP SIGNAL CIRCUIT FOR OPEN CIRCUIT</b> <ul style="list-style-type: none"> <li>Turn ignition key to OFF.</li> <li>Disconnect PCM connector.</li> <li>Connect breakout box with PCM disconnected.</li> <li>Disconnect TP sensor connector.</li> <li>Check for continuity between TP sensor terminal C (harness-side) and breakout box terminal 89.</li> <li>Is there continuity?</li> </ul>	Yes	Go to next step.
		No	Repair or replace suspected harness, then go to Step 8.
6	<b>VERIFY TP SIGNAL CIRCUIT FOR SHORT TO GROUND</b> <ul style="list-style-type: none"> <li>Check for continuity between TP sensor connector terminal C and body ground.</li> <li>Is there continuity?</li> </ul>	Yes	Repair or replace suspected harness, then go to Step 8.
		No	Go to next step.
7	<b>INSPECT TP SENSOR</b> <ul style="list-style-type: none"> <li>Perform TP sensor inspection. (See 01-40B-29 THROTTLE POSITION (TP) SENSOR INSPECTION [FS].)</li> <li>Is TP sensor okay?</li> </ul>	Yes	Go to next step.
		No	Replace TP sensor.
8	<b>VERIFY TROUBLESHOOTING OF DTC P0122 COMPLETED</b> <ul style="list-style-type: none"> <li>Make sure to reconnect all disconnected connectors.</li> <li>Start engine.</li> <li>Clear DTC from PCM memory using WDS or equivalent.</li> <li>Depress and release accelerator pedal several times.</li> <li>Is same DTC present?</li> </ul>	Yes	Replace PCM, then go to next step.
		No	Go to next step.
9	<b>VERIFY AFTER REPAIR PROCEDURE</b> <ul style="list-style-type: none"> <li>Perform "After Repair Procedure". (See 01-02B-9 AFTER REPAIR PROCEDURE [FS].)</li> <li>Is there any DTC present?</li> </ul>	Yes	Go to applicable DTC inspection. (See 01-02B-15 DTC TABLE [FS].)
		No	Troubleshooting completed.

### DTC P0123 [FS]

A3U010201084W18

DTC P0123	TP circuit high input
<b>DETECTION CONDITION</b>	<ul style="list-style-type: none"> <li>If PCM detects TP sensor voltage at PCM terminal 89 is <b>above 4.90 V</b> after engine start, PCM determines that TP circuit has a malfunction.</li> </ul> <b>Diagnostic support note</b> <ul style="list-style-type: none"> <li>This is a continuous monitor (CCM).</li> <li>MIL illuminates if PCM detects the above malfunction conditions during first drive cycle. Therefore, PENDING CODE is not available.</li> <li>FREEZE FRAME DATA is available.</li> <li>DTC is stored in PCM memory.</li> </ul>
<b>POSSIBLE CAUSE</b>	<ul style="list-style-type: none"> <li>TP sensor malfunction</li> <li>Connector or terminal malfunction</li> <li>Open circuit between TP sensor terminal B and PCM terminal 91</li> <li>Short to constant voltage (Vref) supply circuit between TP sensor terminal C and PCM terminal 89</li> <li>PCM malfunction</li> </ul>

# ON-BOARD DIAGNOSTIC [ENGINE CONTROL SYSTEM (FS)]

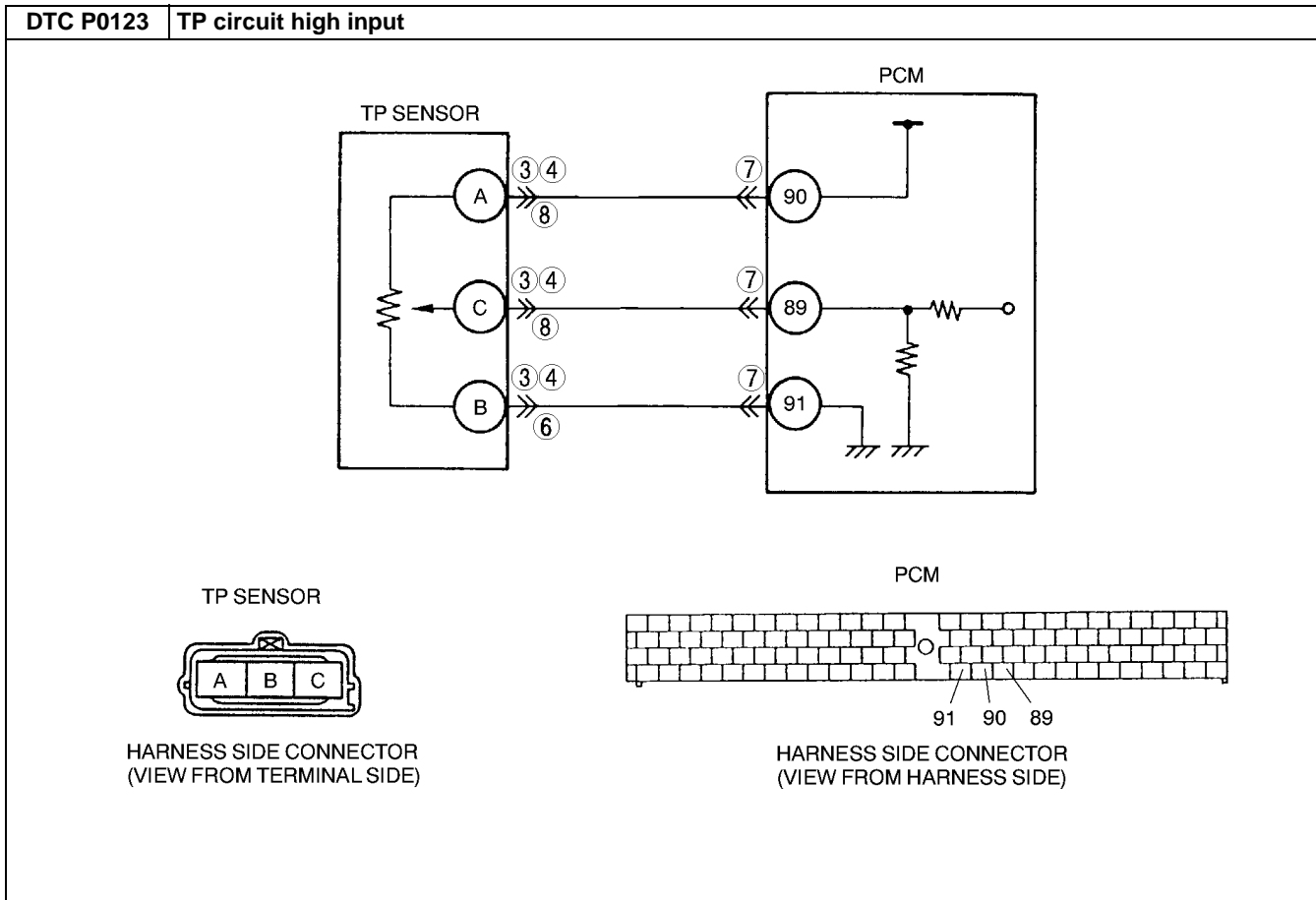

### Diagnostic procedure

STEP	INSPECTION		ACTION
1	<b>VERIFY FREEZE FRAME DATA HAS BEEN RECORDED</b> <ul style="list-style-type: none"> <li>Has FREEZE FRAME DATA been recorded?</li> </ul>	Yes	Go to next step.
		No	Record FREEZE FRAME DATA on repair order, then go to next step.
2	<b>VERIFY RELATED REPAIR INFORMATION AVAILABILITY</b> <ul style="list-style-type: none"> <li>Check for related Service Bulletins availability.</li> <li>Is any related repair information available?</li> </ul>	Yes	Perform repair or diagnosis according to available repair information. <ul style="list-style-type: none"> <li>If vehicle is not repaired, go to next step.</li> </ul>
		No	Go to next step.
3	<b>CHECK TP SENSOR CONNECTOR</b> <ul style="list-style-type: none"> <li>Turn ignition key to OFF.</li> <li>Verify that the TP sensor connector is connected securely.</li> <li>Is connector okay?</li> </ul>	Yes	Go to next step.
		No	Connect the connector securely, then go to Step 9.
4	<b>INSPECT TP SENSOR CONNECTOR FOR POOR CONNECTION</b> <ul style="list-style-type: none"> <li>Disconnect TP sensor connector.</li> <li>Check for poor connection (damaged/pulled-out terminals, corrosion, etc.).</li> <li>Is there any malfunction?</li> </ul>	Yes	Repair or replace suspected terminal, then go to Step 9.
		No	Go to next step.
5	<b>CHECK TP SENSOR RESISTANCE</b> <ul style="list-style-type: none"> <li>Check resistance between following TP sensor terminals (part-side):                              Terminals A and B: <b>Within 3.2—4.8 kilohms</b>                              Terminals B and C: <b>Within 0.2—1.2 kilohms</b> </li> <li>Are both resistances within specifications?</li> </ul>	Yes	Go to next step.
		No	Replace TP sensor, then go to Step 9.
6	<b>VERIFY TP SENSOR GROUND CIRCUIT FOR OPEN CIRCUIT AT TP SENSOR CONNECTOR</b> <ul style="list-style-type: none"> <li>Check for continuity between TP sensor terminal B (harness-side) and body ground.</li> <li>Is there continuity?</li> </ul>	Yes	Go to Step 8.
		No	Go to next step.



## ON-BOARD DIAGNOSTIC [ENGINE CONTROL SYSTEM (FS)]

STEP	INSPECTION	ACTION	
7	<b>CHECK PCM CONNECTOR</b> <ul style="list-style-type: none"> <li>Disconnect PCM connector.</li> <li>Check for poor connection at terminals 89, 90 and 91 (damaged/pulled-out terminals, corrosion, etc.).</li> <li>Is there any malfunction?</li> </ul>	Yes	Repair terminal, then go to Step 9.
		No	Repair or replace open circuit in wiring harness between TP sensor terminal B and PCM connector terminal 91 (harness-side). Then, go to Step 9.
8	<b>VERIFY TP SIGNAL CIRCUIT FOR SHORT TO CONSTANT VOLTAGE CIRCUIT</b> <ul style="list-style-type: none"> <li>Check for continuity between TP sensor terminals A and C.</li> <li>Is there continuity?</li> </ul>	Yes	Repair or replace suspected harness, then go to next step.
		No	Go to next step.
9	<b>VERIFY TROUBLESHOOTING OF DTC P0123 COMPLETED</b> <ul style="list-style-type: none"> <li>Make sure to reconnect all disconnected connectors.</li> <li>Start engine.</li> <li>Clear DTC from PCM memory using WDS or equipment.</li> <li>Depress and release accelerator pedal several times.</li> <li>Does the same DTC appear?</li> </ul>	Yes	Replace PCM, then go to next step.
		No	Go to next step.
10	<b>VERIFY AFTER REPAIR PROCEDURE</b> <ul style="list-style-type: none"> <li>Perform "After Repair Procedure". (See 01-02B-9 AFTER REPAIR PROCEDURE [FS].)</li> <li>Is there any DTC present?</li> </ul>	Yes	Go to applicable DTC inspection. (See 01-02B-15 DTC TABLE [FS].)
		No	Troubleshooting completed.

01-02B

### DTC P0125 [FS]

A3U010201084W19

DTC P0125	Excessive time to enter closed loop fuel control
<b>DETECTION CONDITION</b>	<ul style="list-style-type: none"> <li>PCM monitors ECT sensor signal at PCM terminal 38 after engine is started engine is cold. If ECT voltage does not reach the expected temperature within specified period, PCM determines that it has taken an excessive amount of time for the engine coolant temperature to reach the temperature necessary to start closed-loop fuel control.</li> </ul> <p><b>Diagnostic support note</b></p> <ul style="list-style-type: none"> <li>This is a continuous monitor (CCM).</li> <li>MIL illuminates if PCM detects the above malfunction condition in two consecutive drive cycles.</li> <li>PENDING CODE is available if PCM detects the above malfunction condition during first drive cycle.</li> <li>FREEZE FRAME DATA is available.</li> <li>DTC is stored in PCM memory.</li> </ul>
<b>POSSIBLE CAUSE</b>	<ul style="list-style-type: none"> <li>ECT sensor malfunction</li> <li>Poor connection of connectors</li> <li>PCM malfunction</li> </ul>

### Diagnostic procedure

STEP	INSPECTION	ACTION	
1	<b>VERIFY FREEZE FRAME DATA HAS BEEN RECORDED</b> <ul style="list-style-type: none"> <li>Has FREEZE FRAME DATA been recorded?</li> </ul>	Yes	Go to next step.
		No	Record FREEZE FRAME DATA on repair order, then go to next step.
2	<b>VERIFY RELATED REPAIR INFORMATION AVAILABILITY</b> <ul style="list-style-type: none"> <li>Check for related Service Bulletins availability.</li> <li>Is any related repair information available?</li> </ul>	Yes	Perform repair or diagnosis according to available repair information. <ul style="list-style-type: none"> <li>If vehicle is not repaired, go to next step.</li> </ul>
		No	Go to next step.
3	<b>VERIFY CURRENT INPUT SIGNAL STATUS-IS CONCERN INTERMITTENT OR CONSTANT</b> <ul style="list-style-type: none"> <li>Clear DTC using WDS or equivalent.</li> <li>Start engine.</li> <li>Warm up engine completely.</li> <li>Access ECT PID using WDS or equivalent.</li> <li>Is ECT PID <b>above 35.6 °C {96 °F}</b>?</li> </ul>	Yes	Intermittent concern exists. Go to INTERMITTENT CONCERN TROUBLESHOOTING procedure. (See 01-03B-4 INTERMITTENT CONCERN TROUBLESHOOTING [FS].)
		No	Go to next step.

01-02B-49

## ON-BOARD DIAGNOSTIC [ENGINE CONTROL SYSTEM (FS)]

STEP	INSPECTION	ACTION	
4	<b>INSPECT ECT SENSOR CONNECTOR FOR POOR CONNECTION</b> <ul style="list-style-type: none"> <li>• Turn ignition key to OFF.</li> <li>• Disconnect ECT sensor connector.</li> <li>• Check for poor connection (damaged/pulled-out pins, corrosion, etc.).</li> <li>• Is there malfunction?</li> </ul>	Yes	Repair or replace terminal, then go to Step 7.
		No	Go to next step.
5	<b>INSPECT ECT SENSOR</b> <ul style="list-style-type: none"> <li>• Measure resistance between ECT sensor terminals A and B (part-side).</li> <li>• Is resistance <b>approx. 2 kilohms</b>?</li> </ul>	Yes	Go to next step.
		No	Replace ECT sensor, then go to Step 7.
6	<b>INSPECT PCM CONNECTOR FOR POOR CONNECTION</b> <ul style="list-style-type: none"> <li>• Disconnect PCM connector.</li> <li>• Check for poor connection at terminal 38 and 91 (damaged/pulled-out pins, corrosion, etc.).</li> <li>• Is there malfunction?</li> </ul>	Yes	Repair or replace terminal, then go to Step 7.
		No	Go to next step.
7	<b>VERIFY TROUBLESHOOTING OF DTC P0125 COMPLETED</b> <ul style="list-style-type: none"> <li>• Make sure to reconnect all disconnected connectors.</li> <li>• Turn ignition key to ON (Engine OFF).</li> <li>• Clear DTC from PCM memory using WDS or equivalent.</li> <li>• Access ECT PID using WDS or equivalent.</li> <li>• Wait until ECT PID is <b>below 20 °C {68 °F}</b>.</li> <li>• Start engine and warm it up completely.</li> <li>• Is PENDING CODE of same DTC present?</li> </ul>	Yes	Replace PCM, then go to next step.
		No	Go to next step.
8	<b>VERIFY AFTER REPAIR PROCEDURE</b> <ul style="list-style-type: none"> <li>• Perform "After Repair Procedure". (See 01-02B-9 AFTER REPAIR PROCEDURE [FS].)</li> <li>• Is there any DTC present?</li> </ul>	Yes	Go to applicable DTC inspection. (See 01-02B-15 DTC TABLE [FS].)
		No	Troubleshooting completed.

### DTC P0126, P0128 [FS]

A3U010201084W20

DTC P0126 DTC P0128	Coolant thermostat stuck to open
<b>DETECTION CONDITION</b>	<p><b>DTC P0126</b></p> <ul style="list-style-type: none"> <li>• If ECT signal never exceeds <b>71°C {160°F}</b> after engine start for specified period, PCM determines that the coolant thermostat is stuck open.</li> </ul> <p><b>MONITORING CONDITIONS</b></p> <ul style="list-style-type: none"> <li>— IAT: <b>Above -10°C {14°F}</b></li> <li>— Difference between ECT at engine start and minimum IAT: <b>Below 6°C {43°F}</b></li> <li>— Vehicle speed <b>over 9.5 km/h {5.9 mph}</b></li> </ul> <p><b>DTC P0128</b></p> <ul style="list-style-type: none"> <li>• PCM monitors MAF, IAT, VSS and ECT signals and calculate radiator's heat radiation ratio while following monitoring conditions are met. If calculated value exceeds threshold, PCM determines that the coolant thermostat is stuck open.</li> </ul> <p><b>MONITORING CONDITIONS</b></p> <ul style="list-style-type: none"> <li>— ECT at engine start: <b>Below 35°C {95°F}</b></li> <li>— IAT: <b>Above -10°C {14°F}</b></li> <li>— Difference between ECT at engine start and minimum IAT: <b>Below 6°C {43°F}</b></li> <li>— Vehicle speed <b>above 25 km/h {15 mph}</b> for ATX, <b>40 km/h {25 mph}</b> for MTX</li> </ul> <p><b>Diagnostic support note</b></p> <ul style="list-style-type: none"> <li>• This is a intermittent monitor (THERMOSTAT)</li> <li>• MIL illuminates if PCM detects the above malfunction condition in two consecutive drive cycles.</li> <li>• DIAGNOSTIC MONITORING TEST RESULTS is available.</li> <li>• PENDING CODE is available if PCM detects the above malfunction condition during first drive cycle.</li> <li>• FREEZE FRAME DATA is available.</li> <li>• DTC is stored in PCM memory.</li> </ul>
<b>POSSIBLE CAUSE</b>	<ul style="list-style-type: none"> <li>• Coolant thermostat malfunction</li> <li>• ECT sensor malfunction</li> <li>• PCM malfunction</li> </ul>

# ON-BOARD DIAGNOSTIC [ENGINE CONTROL SYSTEM (FS)]

## Diagnostic procedure

STEP	INSPECTION	ACTION
1	<b>VERIFY FREEZE FRAME DATA HAS BEEN RECORDED</b> <ul style="list-style-type: none"> <li>Has FREEZE FRAME DATA been recorded?</li> </ul>	Yes Go to next step.
		No Record FREEZE FRAME DATA on repair order, then go to next step.
2	<b>VERIFY RELATED REPAIR INFORMATION AVAILABILITY</b> <ul style="list-style-type: none"> <li>Check for related Service Bulletins availability.</li> <li>Is any related repair information available?</li> </ul>	Yes Perform repair or diagnosis according to available repair information. If vehicle is not repaired, then go to next step.
		No Go to next step.
3	<b>INSPECT FOR OTHER DTCs</b> <ul style="list-style-type: none"> <li>Have other DTCs been stored?</li> </ul>	Yes Repair circuit malfunction for applicable DTCs.
		No Go to next step.
4	<b>VERIFY COOLANT THERMOSTAT OPERATION</b> <ul style="list-style-type: none"> <li>Turn off E/L and A/C.</li> <li>Remove cooling fan relay No.1 located next to main relay box.</li> <li>Warm up engine until ECT PID reads <b>99°C {210°F}</b>.</li> <li>Short cooling fan relay No.1 terminal A and B (harness-side) using a jumper wire.</li> <li>Monitor ECT PID.</li> <li>Has ECT PID decreased continuously and stop at <b>80—84°C {176—183°F}</b> (thermostat closed)?</li> </ul>	Yes Go to step 6.
		No Go to next step.
5	<b>INSPECT COOLANT THERMOSTAT FOR WHETHER STUCK OPEN</b> <ul style="list-style-type: none"> <li>Remove coolant thermostat and inspect for stuck open. (See 01-12-7 THERMOSTAT INSPECTION.)</li> <li>Is thermostat okay?</li> </ul>	Yes Inspect ECT sensor. Replace ECT sensor if necessary, then go to next step.
		No Replace coolant thermostat, then go to next step.
6	<b>VERIFY MONITORING CONDITION FOR REPAIR VERIFICATION</b> <ul style="list-style-type: none"> <li>Make sure to reconnect all disconnected connectors.</li> <li>Cool down engine.</li> </ul> <p><b>Note</b></p> <ul style="list-style-type: none"> <li>If workshop inside and outside temperature difference is significant, PCM might not operate thermostat monitor. Therefore, it is recommended to cool down engine out of workshop.</li> </ul> <ul style="list-style-type: none"> <li>Turn ignition key to ON (Engine OFF).</li> <li>Clear DTC from PCM memory using WDS or equivalent.</li> <li>Access ECT, IAT PIDs and make sure that each value is within following conditions.                             <ul style="list-style-type: none"> <li>— ECT: <b>below 31°C {88°F}</b> (for P0128 only)</li> <li>— IAT: <b>above -10°C {14°F}</b></li> <li>— Difference between ECT and IAT: <b>below 6°C {43°F}</b></li> </ul> </li> <li>Is there any PID that is out of specification?</li> </ul>	Yes Take corrective action (e.g. cool down engine), then repeat this step.
		No Go to next step for DTC P0126 or go to step 8 for DTC P0128.

01-02B

## ON-BOARD DIAGNOSTIC [ENGINE CONTROL SYSTEM (FS)]

STEP	INSPECTION	ACTION	
7	<b>VERIFY TROUBLESHOOTING OF DTC P0126 COMPLETED</b> <ul style="list-style-type: none"> <li>• Start engine and turn off E/L and A/C.</li> <li>• Access DIAGNOSIS MONITORING TEST RESULTS using WDS or equivalent and monitor TEST #10:32:00.</li> <li>• Drive vehicle from <b>40—100 km/h {25—62 mph}</b> until TEST value is changed.</li> </ul> <p><b>Note</b></p> <ul style="list-style-type: none"> <li>• This test requires actual driving. Chassis roller cannot be used for this test.</li> <li>• During test drive, constant speed should be maintained, although 2 or 3 stops during every <b>5 minutes</b> of driving time (e.g. for traffic signals) is acceptable. Stop-and-go (e.g. in case of traffic congestion) is not acceptable during the test period.</li> <li>• Test period depends on ECT at engine start. (e.g. If ECT is <b>-10°C {14°F}</b>, monitoring period is <b>38 minutes</b> and if ECT is <b>30°C {86°F}</b>, monitoring period is <b>8 minutes</b>)</li> </ul> <ul style="list-style-type: none"> <li>• Verify TEST #10:32:00 value.</li> <li>• Is value above minimum value?</li> </ul>	Yes	Go to step 9.
		No	Replace PCM, then go to step 9.
8	<b>VERIFY TROUBLESHOOTING OF DTC P0128 COMPLETED</b> <ul style="list-style-type: none"> <li>• Start engine and turn off E/L and A/C.</li> <li>• Access DIAGNOSIS MONITORING TEST RESULTS using WDS or equivalent and monitor TEST #10:31:00 or #10:30:00.</li> <li>• Drive vehicle from <b>40—100 km/h {25—62 mph}</b> for approximately <b>5 minutes</b> until TEST value is changed.</li> </ul> <p><b>Note</b></p> <ul style="list-style-type: none"> <li>• This test requires actual driving. Chassis roller cannot be used for this test.</li> <li>• During test drive, constant speed should be maintained, although 2 or 3 stops (e.g. for traffic signals) is acceptable. Stop-and-go (e.g. in case of traffic congestion) is not acceptable during the test period.</li> </ul> <ul style="list-style-type: none"> <li>• Verify TEST #10:31:00 or #10:30:00 value.</li> <li>• Is value below maximum value?</li> </ul>	Yes	Go to next step.
		No	Replace PCM, then go to next step.
9	<b>VERIFY AFTER REPAIR PROCEDURE</b> <ul style="list-style-type: none"> <li>• Perform "After Repair Procedure". (See 01-02B-9 AFTER REPAIR PROCEDURE [FS].)</li> <li>• Is there any DTC present?</li> </ul>	Yes	Go to applicable DTC inspection. (See 01-02B-15 DTC TABLE [FS].)
		No	Troubleshooting completed.

### DTC P0131 [FS]

A3U010201084W21

DTC P0131	HO2S (front) no inversion (low voltage stuck)
<b>DETECTION CONDITION</b>	<ul style="list-style-type: none"> <li>• PCM monitors input voltage from HO2S (front) when the following monitoring conditions are met. If input voltage from sensor remains <b>below 0.45 V</b> for <b>42.8 s</b>, PCM determines that there is no HO2S (front) inversion.</li> </ul> <p><b>MONITORING CONDITIONS</b></p> <ul style="list-style-type: none"> <li>— Engine speed is <b>above 1,500 rpm</b>.</li> <li>— Engine coolant temperature is <b>above 70 °C {158 °F}</b>.</li> </ul> <p><b>Diagnostic support note</b></p> <ul style="list-style-type: none"> <li>• This is a continuous monitor (CCM).</li> <li>• MIL illuminates if PCM detects the above malfunction condition in two consecutive drive cycles.</li> <li>• PENDING CODE is available if PCM detects the above malfunction condition during first drive cycle.</li> <li>• FREEZE FRAME DATA is available.</li> <li>• DTC is stored in PCM memory.</li> </ul>

## ON-BOARD DIAGNOSTIC [ENGINE CONTROL SYSTEM (FS)]

01-02B

<b>DTC P0131</b>	<b>HO2S (front) no inversion (low voltage stuck)</b>
<b>POSSIBLE CAUSE</b>	<ul style="list-style-type: none"> <li>HO2S (front) malfunction</li> <li>HO2S (front) heater malfunction</li> <li>Fuel injector malfunction</li> <li>Pressure regulator malfunction</li> <li>Fuel pump malfunction</li> <li>Fuel delivery hose leakage</li> <li>Fuel filter clogging</li> <li>Fuel return hose leakage</li> <li>Air suction or leakage</li> <li>PCV valve malfunction</li> <li>Purge solenoid valve malfunction</li> <li>Purge solenoid hoses are hooked up incorrectly.</li> <li>Ignition coil malfunction</li> <li>Insufficient compression</li> <li>Engine malfunction</li> </ul>

### Diagnostic procedure

STEP	INSPECTION		ACTION
1	<b>VERIFY FREEZE FRAME DATA HAS BEEN RECORDED</b> <ul style="list-style-type: none"> <li>Has FREEZE FRAME DATA been recorded?</li> </ul>	Yes	Go to next step.
		No	Record FREEZE FRAME DATA on repair order, then go to next step.
2	<b>VERIFY RELATED REPAIR INFORMATION AVAILABILITY</b> <ul style="list-style-type: none"> <li>Check for related Service Bulletins availability.</li> <li>Is any related repair information available?</li> </ul>	Yes	Perform repair or diagnosis according to available repair information. <ul style="list-style-type: none"> <li>If vehicle is not repaired, go to next step.</li> </ul>
		No	Go to next step.
3	<b>VERIFY RELATED PENDING AND STORED DTCs</b> <ul style="list-style-type: none"> <li>Turn ignition key to OFF, then start engine.</li> <li>Verify pending and stored DTCs using WDS or equivalent.</li> <li>Are other DTCs present?</li> </ul>	Yes	Go to appropriate DTC troubleshooting procedures.
		No	Go to next step.
4	<b>IDENTIFY TRIGGER DTC FOR FREEZE FRAME DATA</b> <ul style="list-style-type: none"> <li>Is DTC P0131 on FREEZE FRAME DATA?</li> </ul>	Yes	Go to next step.
		No	Go to troubleshooting procedures for DTC on FREEZE FRAME DATA.
5	<b>VERIFY CURRENT INPUT SIGNAL STATUS IS CONCERN INTERMITTENT OR CONSTANT</b> <ul style="list-style-type: none"> <li>Warm up engine.</li> <li>Access O2S11 PID using WDS or equivalent.</li> <li>Verify PID while racing engine (in PARK).</li> <li>Is PID reading okay?                             <ul style="list-style-type: none"> <li>— <b>More than 0.45 V</b> when suddenly depressing accelerator pedal (rich condition)</li> <li>— <b>Less than 0.45 V</b> just after release of accelerator pedal (lean condition)</li> </ul> </li> </ul>	Yes	Go to next step.
		No	Replace HO2S (front), then go to Step 18.
6	<b>INSPECT PURGE SOLENOID VALVE OPERATION</b> <ul style="list-style-type: none"> <li>Turn ignition key to OFF.</li> <li>Inspect purge solenoid valve operation.</li> <li>Is purge solenoid valve okay?</li> </ul>	Yes	Go to Step 11.
		No	Replace purge solenoid valve. Then go to Step 18.
7	<b>INSPECT PCV VALVE OPERATION</b> <ul style="list-style-type: none"> <li>Inspect PCV valve operation. (See 01-16-18 POSITIVE CRANKCASE VENTILATION (PCV) VALVE INSPECTION.)</li> <li>Is PCV valve okay?</li> </ul>	Yes	Go to next step.
		No	Replace PCV, then go to Step 18.
8	<b>INSPECT FUEL LINE PRESSURE (LOW FUEL LINE PRESSURE)</b> <ul style="list-style-type: none"> <li>start engine.</li> <li>Inspect fuel line pressure while engine running. (See 01-14-6 FUEL PRESSURE INSPECTION.)</li> <li>Is fuel line pressure <b>within 210—250 kPa {2.1—2.6 kgf/cm<sup>2</sup>, 30—36 psi}</b>?</li> </ul>	Yes	Go to Step 11.
		No	Go to next step.

## ON-BOARD DIAGNOSTIC [ENGINE CONTROL SYSTEM (FS)]

STEP	INSPECTION	ACTION	
9	<b>INSPECT FUEL LINE FROM FUEL PUMP TO FUEL DELIVERY PUMP</b> <ul style="list-style-type: none"> <li>• Visually inspect fuel line for any leakage.</li> <li>• Is any fuel leakage found?</li> </ul>	Yes	Replace suspected fuel line, then go to Step 18.
		No	Inspect fuel filters for following: <ul style="list-style-type: none"> <li>• Restriction or clogging at fuel filter (high-pressure)</li> <li>• Foreign material or stain inside fuel filter (low-pressure)                             <ul style="list-style-type: none"> <li>— If restriction or clogging is found at fuel filter (high-pressure), replace fuel filter (high-pressure).</li> <li>— If foreign material or stain is found inside fuel filter (low-pressure), clean fuel tank and fuel filter (low-pressure).</li> </ul> </li> <li>— If all items above are okay, go to next step.</li> </ul>
10	<b>INSPECT FUEL PUMP MAXIMUM PRESSURE</b> <ul style="list-style-type: none"> <li>• Stop engine.</li> <li>• Turn ignition key to ON (Engine OFF).</li> <li>• Perform fuel pump maximum pressure test. (See 01–14–17 Fuel Pump Maximum Pressure Inspection.)</li> <li>• Is fuel pump maximum pressure <b>within 450—630 kPa {4.5—6.5 kgf/cm<sup>2</sup>, 64—92 psi}</b>?</li> </ul>	Yes	Replace pressure regulator, then go to step 18.
		No	Inspect fuel pump circuit for open or poor connection. <ul style="list-style-type: none"> <li>• Repair or replace suspected circuit.</li> <li>• If circuit is okay, replace fuel pump.</li> </ul> Then go to Step 18.
11	<b>CHECK IGNITION COIL OPERATION AND HIGH-TENSION LEAD WITH TIMING LIGHT</b> <ul style="list-style-type: none"> <li>• Verify blinking condition on each cylinder using timing light at idle.</li> <li>• Do all cylinders show blinking condition?</li> </ul>	Yes	Go to Step 15.
		No	Go to next step.
12	<b>CHECK HIGH-TENSION LEADS OF NON-BLINKING CYLINDER</b> <ul style="list-style-type: none"> <li>• Turn ignition key to OFF.</li> <li>• Inspect high-tension leads for installation condition, corrosion on terminal, open lead and damaged cover.</li> <li>• Is condition of high-tension lead okay?</li> </ul>	Yes	Go to next step.
		No	Replace faulty high-tension lead, then go to Step 18.
13	<b>INSPECT POWER SUPPLY TERMINAL AT IGNITION COIL CONNECTOR</b> <ul style="list-style-type: none"> <li>• Disconnect ignition coil connector.</li> <li>• Turn ignition key to ON (Engine OFF).</li> <li>• Measure voltage between ignition coil connector terminal D (harness-side) and body ground.</li> <li>• Is voltage reading <b>B+</b>?</li> </ul>	Yes	Go to next step.
		No	Check for open circuit between ignition coil connector and ignition switch. Repair or replace wiring harness, then go to Step 18.
14	<b>INSPECT IGNITION COIL RESISTANCE</b> <ul style="list-style-type: none"> <li>• Check ignition coil resistance. (See 01–18–2 IGNITION COIL INSPECTION.)</li> <li>• Is coil resistance okay?</li> </ul>	Yes	Go to next step.
		No	Replace ignition coil, then go to Step 18.
15	<b>INSPECT ENGINE COMPRESSION</b> <ul style="list-style-type: none"> <li>• Inspect engine compression. (See 01–10B–8 COMPRESSION INSPECTION [FS].)</li> <li>• Is it okay?</li> </ul>	Yes	Go to next step.
		No	Implement engine overhaul for repairs, then go to next step.
16	<b>INSPECT FUEL INJECTOR OPERATION</b> <ul style="list-style-type: none"> <li>• Turn ignition key to OFF.</li> <li>• Inspect injector. (See 01–14–24 FUEL INJECTOR INSPECTION.)</li> <li>• Is injector okay?</li> </ul>	Yes	Go to next step.
		No	Replace injector, then go to Step 18.

## ON-BOARD DIAGNOSTIC [ENGINE CONTROL SYSTEM (FS)]

01-02B

STEP	INSPECTION		ACTION
17	<b>INSPECT SEALING OF ENGINE COOLANT PASSAGE</b>  <b>Warning</b> <ul style="list-style-type: none"> <li>Removing radiator cap when radiator is hot is dangerous. Scalding coolant and steam may shoot out and cause serious injury.</li> <li>When removing radiator cap, wrap a thick cloth around and turn it slowly.</li> </ul> <ul style="list-style-type: none"> <li>Remove radiator cap.</li> <li>Implement procedure to bleed air from engine coolant, then run engine at idle.</li> <li>Is there any small bubble which makes engine coolant white at filling opening?</li> </ul> <b>Note</b> <ul style="list-style-type: none"> <li>Large bubbles are normal since they are remaining air coming out from engine coolant passage.</li> </ul>	Yes	Air gets in from poor sealing to head gasket or other areas between combustion chamber and engine coolant passage. Repair or replace faulty parts, then go to next step.
		No	Go to next step.
18	<b>VERIFY TROUBLESHOOTING OF DTC P0131 COMPLETED</b> <ul style="list-style-type: none"> <li>Make sure to reconnect all disconnected connectors.</li> <li>Turn ignition key to ON (Engine OFF).</li> <li>Clear DTC from memory using WDS or equivalent.</li> <li>Start engine.</li> <li>Access ECT and RPM PIDs using WDS or equivalent.</li> <li>Make sure that ECT PID is <b>above 70 °C {158 °F}</b>.</li> <li>Increase and keep engine speed <b>above 1,500 rpm</b> for at <b>least 1 minute</b>.</li> <li>Is pending code of same DTC present?</li> </ul>	Yes	Replace or reprogram PCM. Then go to next step.
		No	Go to next step.
19	<b>VERIFY AFTER REPAIR PROCEDURE</b> <ul style="list-style-type: none"> <li>Perform "After Repair Procedure". (See 01-02B-9 AFTER REPAIR PROCEDURE [FS].)</li> <li>Is there any DTC present?</li> </ul>	Yes	Go to applicable DTC inspection. (See 01-02B-15 DTC TABLE [FS].)
		No	Troubleshooting completed.

### DTC P0132 [FS]

A3U010201084W22

DTC P0132	HO2S (front) no inversion (high voltage stuck)
<b>DETECTION CONDITION</b>	<ul style="list-style-type: none"> <li>PCM monitors input voltage from HO2S (front) when the following monitoring conditions are met. If input voltage from sensor remains <b>above 0.45 V</b> for <b>42.8 s</b>, PCM determines that there is no HO2S (front) inversion.</li> </ul> <b>MONITORING CONDITIONS</b> <ul style="list-style-type: none"> <li>— Engine speed is <b>above 1,500 rpm</b>.</li> <li>— Engine coolant temperature is <b>above 70 °C {158 °F}</b>.</li> </ul> <b>Diagnostic support note</b> <ul style="list-style-type: none"> <li>This is a continuous monitor (CCM).</li> <li>MIL illuminates if PCM detects the above malfunction condition in two consecutive drive cycles.</li> <li>PENDING CODE is available if PCM detects the above malfunction condition during first drive cycle.</li> <li>FREEZE FRAME DATA is available.</li> <li>DTC is stored in PCM memory.</li> </ul>
<b>POSSIBLE CAUSE</b>	<ul style="list-style-type: none"> <li>HO2S (front) malfunction</li> <li>HO2S (front) heater malfunction</li> <li>Fuel injector malfunction</li> <li>Pressure regulator malfunction</li> <li>Fuel pump malfunction</li> <li>Fuel return hose clogging</li> <li>PCV valve malfunction</li> <li>Purge solenoid valve malfunction</li> <li>Purge solenoid hoses are hooked up incorrectly.</li> <li>Engine malfunction</li> </ul>

## ON-BOARD DIAGNOSTIC [ENGINE CONTROL SYSTEM (FS)]

### Diagnostic procedure

STEP	INSPECTION	ACTION	
1	<b>VERIFY FREEZE FRAME DATA HAS BEEN RECORDED</b> <ul style="list-style-type: none"> <li>• Has FREEZE FRAME DATA been recorded?</li> </ul>	Yes	Go to next step.
		No	Record FREEZE FRAME DATA on repair order, then go to next step.
2	<b>VERIFY RELATED REPAIR INFORMATION AVAILABILITY</b> <ul style="list-style-type: none"> <li>• Check for related Service Bulletins availability.</li> <li>• Is any related repair information available?</li> </ul>	Yes	Perform repair or diagnosis according to available repair information. <ul style="list-style-type: none"> <li>• If vehicle is not repaired, go to next step.</li> </ul>
		No	Go to next step.
3	<b>VERIFY RELATED PENDING AND STORED DTCs</b> <ul style="list-style-type: none"> <li>• Turn ignition key to OFF, then start engine.</li> <li>• Verify pending and stored DTCs using WDS or equivalent.</li> <li>• Are other DTCs present?</li> </ul>	Yes	Go to appropriate DTC troubleshooting procedures.
		No	Go to next step.
4	<b>IDENTIFY TRIGGER DTC FOR FREEZE FRAME DATA</b> <ul style="list-style-type: none"> <li>• Is DTC P0132 on FREEZE FRAME DATA?</li> </ul>	Yes	Go to next step.
		No	Go to troubleshooting procedures for DTC on FREEZE FRAME DATA.
5	<b>VERIFY CURRENT INPUT SIGNAL STATUS IS CONCERN INTERMITTENT OR CONSTANT</b> <ul style="list-style-type: none"> <li>• Warm up engine.</li> <li>• Access O2S11 PID using WDS or equivalent.</li> <li>• Verify PID while racing engine (in PARK).</li> <li>• Is PID reading okay?                             <ul style="list-style-type: none"> <li>— <b>More than 0.45 V</b> when suddenly depressing accelerator pedal (rich condition)</li> <li>— <b>Less than 0.45 V</b> just after release of accelerator pedal (lean condition)</li> </ul> </li> </ul>	Yes	Go to next step.
		No	Replace HO2S (front), then go to Step 12.
6	<b>INSPECT FUEL LINE PRESSURE (EXCESSIVE FUEL LINE PRESSURE)</b> <ul style="list-style-type: none"> <li>• Start engine.</li> <li>• Inspect fuel line pressure while engine running. (See 01-14-6 FUEL PRESSURE INSPECTION.)</li> <li>• Is fuel line pressure <b>within 210—250 kPa {2.1—2.6 kgf/cm<sup>2</sup>, 30—36 psi}</b>?</li> </ul>	Yes	Go to Step 9.
		No	Go to next step.
7	<b>VERIFY VACUUM IS LEADING TO PRESSURE REGULATOR</b> <ul style="list-style-type: none"> <li>• Disconnect vacuum hose from pressure regulator.</li> <li>• Verify that vacuum is felt at opening port of disconnected vacuum hose.</li> <li>• Is vacuum felt?</li> </ul>	Yes	Inspect following parts and repair or replace if necessary: <ul style="list-style-type: none"> <li>• Fuel pump maximum pressure</li> <li>• Fuel return pipe for clogging                             <ul style="list-style-type: none"> <li>— If all items above are okay, replace pressure regulator. Then, go to Step 12.</li> </ul> </li> </ul>
		No	Verify vacuum hoses are connected correctly. <ul style="list-style-type: none"> <li>• If okay, replace PRC solenoid valve. Then go to Step 12.</li> <li>• If not, reconnect vacuum hoses to correct position. Then go to Step 12.</li> </ul>
8	<b>INSPECT PURGE SOLENOID VALVE OPERATION</b> <ul style="list-style-type: none"> <li>• Turn ignition key to OFF.</li> <li>• Inspect purge solenoid valve operation.</li> <li>• Is purge solenoid valve okay?</li> </ul>	Yes	Go to Step 10.
		No	Replace purge solenoid valve. Then go to Step 12.
9	<b>INSPECT PCV VALVE OPERATION</b> <ul style="list-style-type: none"> <li>• Inspect PCV valve operation. (See 01-16-18 POSITIVE CRANKCASE VENTILATION (PCV) VALVE INSPECTION.)</li> <li>• Is PCV valve okay?</li> </ul>	Yes	Go to next step.
		No	Replace PCV, then go to Step 12.
10	<b>INSPECT FUEL INJECTOR OPERATION</b> <ul style="list-style-type: none"> <li>• Turn ignition key to OFF.</li> <li>• Inspect injector. (See 01-14-24 FUEL INJECTOR INSPECTION.)</li> <li>• Is injector okay?</li> </ul>	Yes	Go to next step.
		No	Replace injector, then go to Step 12.



## ON-BOARD DIAGNOSTIC [ENGINE CONTROL SYSTEM (FS)]

STEP	INSPECTION	ACTION	
11	<b>INSPECT SEALING OF ENGINE COOLANT PASSAGE</b>  <b>Warning</b> <ul style="list-style-type: none"> <li>• Removing radiator cap when radiator is hot is dangerous. Scalding coolant and steam may shoot out and cause serious injury.</li> <li>• When removing radiator cap, wrap a thick cloth around and turn it slowly.</li> </ul> <ul style="list-style-type: none"> <li>• Remove radiator cap.</li> <li>• Implement procedure to bleed air from engine coolant, then run engine at idle.</li> <li>• Is there any small bubble which makes engine coolant white at filling opening?</li> </ul> <b>Note</b> <ul style="list-style-type: none"> <li>• Large bubbles are normal since they are remaining air coming out from engine coolant passage.</li> </ul>	Yes	Air gets in from poor sealing to head gasket or other areas between combustion chamber and engine coolant passage. Repair or replace faulty parts, then go to next step.
		No	Go to next step.
12	<b>VERIFY TROUBLESHOOTING OF DTC P0132 COMPLETED</b> <ul style="list-style-type: none"> <li>• Make sure to reconnect all disconnected connectors.</li> <li>• Turn ignition key to ON (Engine OFF).</li> <li>• Clear DTC from memory using WDS or equivalent.</li> <li>• Start engine.</li> <li>• Access ECT and RPM PIDs using WDS or equivalent.</li> <li>• Make sure that ECT PID is <b>above 70 °C {158 °F}</b>.</li> <li>• Increase and keep engine speed <b>above 1,500 rpm</b> for at <b>least 1 minute</b>.</li> <li>• Is pending code of same DTC present?</li> </ul>	Yes	Replace or reprogram PCM. Then go to next step.
		No	Go to next step.
13	<b>VERIFY AFTER REPAIR PROCEDURE</b> <ul style="list-style-type: none"> <li>• Perform "After Repair Procedure". (See 01-02B-9 AFTER REPAIR PROCEDURE [FS].)</li> <li>• Is there any DTC present?</li> </ul>	Yes	Go to applicable DTC inspection. (See 01-02B-15 DTC TABLE [FS].)
		No	Troubleshooting completed.

01-02B

### DTC P0133 [FS]

A3U010201084W23

DTC P0133	HO2S (Front) circuit slow response
<b>DETECTION CONDITION</b>	<ul style="list-style-type: none"> <li>• PCM monitors inversion cycle period, lean-to-rich response time and rich-to-lean response time of the sensor. PCM calculates the average of the inversion cycle period-specified inversion cycles, average response time from lean-to-rich, and from rich-to-lean when monitoring conditions are met. If any exceeds threshold, PCM determines that circuit has malfunction.</li> </ul> <b>MONITORING CONDITIONS</b> <ul style="list-style-type: none"> <li>— Drive mode 3</li> <li>— Following conditions are met:                             <ul style="list-style-type: none"> <li>• Calculation load is <b>20—59%</b> [at engine speed <b>2,000 rpm</b>]</li> <li>• Engine speed is <b>1,410—4,000 rpm</b></li> <li>• Vehicle speed is <b>over 3.77 km/h {2.34 mph}</b>.</li> <li>• Engine coolant temperature is <b>above -10°C {14°F}</b>.</li> </ul> </li> </ul> <b>Diagnostic support note</b> <ul style="list-style-type: none"> <li>• This is an intermittent monitor. (OXYGEN SENSOR)</li> <li>• MIL illuminates if PCM detects either of above malfunction conditions in two consecutive drive cycles.</li> <li>• DIAGNOSTIC MONITORING TEST RESULTS is available.</li> <li>• PENDING CODE is available if PCM detects the above malfunction condition during first drive cycle.</li> <li>• FREEZE FRAME DATA is available.</li> <li>• DTC is stored in PCM memory.</li> </ul>

## ON-BOARD DIAGNOSTIC [ENGINE CONTROL SYSTEM (FS)]

<b>DTC P0133</b>	<b>HO2S (Front) circuit slow response</b>
<b>POSSIBLE CAUSE</b>	<ul style="list-style-type: none"> <li>• Front HO2S deterioration</li> <li>• Front HO2S heater malfunction</li> <li>• PRC solenoid valve malfunction</li> <li>• Pressure regulator malfunction</li> <li>• Fuel pump malfunction</li> <li>• Fuel filter clogged or restricted</li> <li>• Fuel leakage on fuel line from fuel distribution pipe and fuel pump</li> <li>• Fuel return hose clogged</li> <li>• Leakage from exhaust system</li> <li>• Purge solenoid valve malfunction</li> <li>• Purge solenoid hoses improper connection</li> <li>• Insufficient compression</li> <li>• Engine malfunction</li> </ul>

### Diagnostic procedure

STEP	INSPECTION		ACTION
1	<b>VERIFY FREEZE FRAME DATA HAS BEEN RECORDED</b> • Has FREEZE FRAME DATA been recorded?	Yes	Go to next step.
		No	Record FREEZE FRAME DATA on repair order, then go to next step.
2	<b>VERIFY RELATED REPAIR INFORMATION AVAILABILITY</b> • Check for related Service Bulletins availability. • Is any related repair information available?	Yes	Perform repair or diagnosis according to available repair information. • If vehicle is not repaired, go to next step.
		No	Go to next step.
3	<b>VERIFY RELATED PENDING AND STORED DTCS</b> • Turn ignition key to OFF, then start engine. • Verify pending and/or stored DTCS using WDS or equivalent. • Is the following DTC also present? — P0442, P0443, P0455, P0031, P0032 or P1450 with P0133	Yes	Go to appropriate DTC troubleshooting procedures, then go to Step 15. (See 01–02B–15 DTC TABLE [FS].)
		No	Go to next step.
4	<b>IDENTIFY TRIGGER DTC FOR FREEZE FRAME DATA</b> • Is DTC P0133 on FREEZE FRAME DATA?	Yes	Go to next step.
		No	Go to troubleshooting procedures for DTC on FREEZE FRAME DATA. (See 01–02B–15 DTC TABLE [FS].)
5	<b>VERIFY CURRENT INPUT SIGNAL STATUS</b> • Warm up engine. • Access O2S11 PID using WDS or equivalent. • Check PID under following accelerator pedal conditions (in PARK). — <b>More than 0.45 V</b> when suddenly depressing accelerator pedal (rich condition) — <b>Less than 0.45 V</b> just after release of accelerator pedal (lean condition) • Is PID reading okay?	Yes	Go to Step 8.
		No	Go to next step.
6	<b>INSPECT INSTALLATION OF FRONT HO2S</b> • Check if HO2S (front) is loosely installed. • Is sensor installed securely?	Yes	Go to next step.
		No	Retighten sensor, then go to Step 15.
7	<b>INSPECT EXHAUST SYSTEM FOR GAS LEAKAGE</b> • Visually check if any gas leakage is found between exhaust manifold and HO2S (front). • Is there any gas leakage?	Yes	Repair or replace any faulty exhaust parts, then go to Step 15.
		No	Replace sensor, then go to Step 15.
8	<b>INSPECT LONG TERM FUEL TRIM</b> • Access LONGFT1 PIDs. • Compare it with FREEZE FRAME DATA (FFD) recorded at Step 1. • Is it below FFD value?	Yes	Engine is driven under rich condition. Go to next step.
		No	Engine is driven under lean condition. Go to Step 11.

## ON-BOARD DIAGNOSTIC [ENGINE CONTROL SYSTEM (FS)]

STEP	INSPECTION	ACTION	
9	<b>INSPECT FUEL LINE PRESSURE (Excessive fuel line pressure)</b> <ul style="list-style-type: none"> <li>• Start engine.</li> <li>• Inspect fuel line pressure while engine running. (See 01-14-6 FUEL PRESSURE INSPECTION.)</li> <li>• Is fuel line pressure <b>within 210—250 kPa {2.1—2.6 kgf/cm<sup>2</sup>, 30—36 psi}</b>?</li> </ul>	Yes	Go to Step 14.
		No	Go to next step.
10	<b>VERIFY VACUUM IS LEADING TO PRESSURE REGULATOR</b> <ul style="list-style-type: none"> <li>• Disconnect vacuum hose from pressure regulator.</li> <li>• Verify that vacuum is felt at opening port of disconnected vacuum hose.</li> <li>• Is vacuum felt?</li> </ul>	Yes	Inspect fuel pump maximum pressure and fuel return pipe for clogging. (See 01-14-15 FUEL PUMP UNIT INSPECTION.) <ul style="list-style-type: none"> <li>• If any problem is found, repair or replace suspected parts.</li> <li>• If all items above are okay, replace pressure regulator. Then go to Step 15.</li> </ul>
		No	Verify vacuum hoses are connected correctly. <ul style="list-style-type: none"> <li>• If okay, replace PRC solenoid valve.</li> <li>• If not, reconnect vacuum hoses to correct position. Then go to Step 15.</li> </ul>
11	<b>INSPECT FUEL LINE PRESSURE (Low fuel line pressure)</b> <ul style="list-style-type: none"> <li>• Start engine.</li> <li>• Inspect fuel line pressure while engine running. (See 01-14-6 FUEL PRESSURE INSPECTION.)</li> <li>• Is fuel line pressure <b>within 210—250 kPa {2.1—2.6 kgf/cm<sup>2</sup>, 30—36 psi}</b>?</li> </ul>	Yes	Go to Step 14.
		No	Go to next step.
12	<b>INSPECT FUEL LINE FROM FUEL PUMP TO FUEL DELIVERY PIPE</b> <ul style="list-style-type: none"> <li>• Visually inspect fuel line for any leakage.</li> <li>• Is any fuel leakage found?</li> </ul>	Yes	Replace suspected fuel line, then go to Step 15.
		No	Inspect fuel filters for following: <ul style="list-style-type: none"> <li>• Restriction or clogging at fuel filter (high-pressure)</li> <li>• Foreign material or stain inside fuel filter (low-pressure)</li> </ul> Perform following actions as result. <ul style="list-style-type: none"> <li>• If restriction or clogging is found at fuel filter (high-pressure), replace fuel filter (high-pressure).</li> <li>• If foreign material or stain is found inside fuel filter (low-pressure), clean fuel tank and fuel filter (low-pressure).</li> <li>• If all items above are okay, go to next step.</li> </ul>
13	<b>INSPECT FUEL PUMP MAXIMUM PRESSURE</b> <ul style="list-style-type: none"> <li>• Perform fuel pump maximum pressure test. (See 01-14-15 FUEL PUMP UNIT INSPECTION.)</li> <li>• Is fuel pump maximum pressure <b>within 450—630 kPa {4.5—6.5 kgf/cm<sup>2</sup>, 64—92 psi}</b>?</li> </ul>	Yes	Replace pressure regulator, then go to step 15.
		No	Inspect fuel pump circuit for open or poor connection. <ul style="list-style-type: none"> <li>• Repair or replace suspected circuit.</li> <li>• If circuit is okay, replace fuel pump. Then go to Step 15.</li> </ul>
14	<b>INSPECT SEALING OF ENGINE COOLANT PASSAGE</b> <p><b>Warning</b></p> <ul style="list-style-type: none"> <li>• <b>Removing radiator cap when radiator is hot is dangerous. Scalding coolant and steam may shoot out and cause serious injury.</b></li> <li>• <b>When removing radiator cap, wrap a thick cloth around and turn it slowly.</b></li> </ul> <ul style="list-style-type: none"> <li>• Remove radiator cap.</li> <li>• Implement procedure to bleed air from engine coolant, then run engine at idle.</li> <li>• Is there any small bubble, which makes engine coolant white at filling opening?</li> </ul> <p><b>Note</b></p> <ul style="list-style-type: none"> <li>• Large bubbles are normal since they are remaining air coming out from engine coolant passage.</li> </ul>	Yes	Air gets in from poor sealing on head gasket or other areas between combustion chamber and engine coolant passage. Repair or replace faulty parts, then go to next step.
		No	Go to next step.

01-02B

## ON-BOARD DIAGNOSTIC [ENGINE CONTROL SYSTEM (FS)]

STEP	INSPECTION	ACTION	
15	<b>VERIFY TROUBLESHOOTING OF DTC P0133 COMPLETED</b> <ul style="list-style-type: none"> <li>• Make sure to reconnect all disconnected connectors.</li> <li>• Turn ignition key to ON (Engine OFF).</li> <li>• Clear DTC from memory using WDS or equivalent.</li> <li>• Start engine.</li> <li>• Run OBD-II DRIVE MODE 1 and 3. (See 01-02B-10 OBD-II DRIVE MODE [FS].)</li> <li>• Stop vehicle and access ON BOARD SYSTEM READINESS TEST to inspect DRIVE MODE completion status.</li> <li>• Verify RFC changes to YES for OXYGEN SENSOR. — If not, run DRIVE MODE again.</li> <li>• Access DIAGNOSTIC MONITORING TEST RESULTS.</li> <li>• Verify following TEST # values: — 10:01:11, 10:02:11 or 10:03:11</li> <li>• Are they all below MAX value?</li> </ul>	Yes	Go to next step.
		No	Replace PCM, then go to next step.
16	<b>VERIFY AFTER REPAIR PROCEDURE</b> <ul style="list-style-type: none"> <li>• Perform "After Repair Procedure". (See 01-02B-9 AFTER REPAIR PROCEDURE [FS].)</li> <li>• Is there any DTC present?</li> </ul>	Yes	Go to applicable DTC inspection. (See 01-02B-15 DTC TABLE [FS].)
		No	Troubleshooting completed.

# ON-BOARD DIAGNOSTIC [ENGINE CONTROL SYSTEM (FS)]

**DTC P0134 [FS]**

A3U010201084W24

01-02B

<b>DTC P0134</b>	<b>HO2S (Front) circuit no activity detected</b>
<b>DETECTION CONDITION</b>	<ul style="list-style-type: none"> <li>PCM monitors input voltage from HO2S (front) when the following monitoring conditions are met. If input voltage from sensor never <b>exceed 0.55 V</b> for <b>120 seconds</b>, PCM determines that sensor circuit is not activated.</li> </ul> <p><b>MONITORING CONDITIONS</b></p> <ul style="list-style-type: none"> <li>— Drive mode 3</li> <li>— Following conditions are met:             <ul style="list-style-type: none"> <li>• Engine speed is <b>above 1,500 rpm</b>.</li> <li>• Engine coolant temperature is <b>above 70 °C {158 °F}</b>.</li> </ul> </li> </ul> <p><b>Diagnostic support note</b></p> <ul style="list-style-type: none"> <li>• This is a continuous monitor (CCM).</li> <li>• MIL illuminates if PCM detects the above malfunction condition in two consecutive drive cycles.</li> <li>• PENDING CODE is available if PCM detects the above malfunction condition during first drive cycle.</li> <li>• FREEZE FRAME DATA is available.</li> <li>• DTC is stored in PCM memory.</li> </ul>
<b>POSSIBLE CAUSE</b>	<ul style="list-style-type: none"> <li>• HO2S (front) deterioration</li> <li>• HO2S (front) heater malfunction</li> <li>• Leakage from exhaust system</li> <li>• Open or short to ground circuit between HO2S (front) terminal A and PCM terminal 60</li> <li>• Insufficient compression</li> <li>• Engine malfunction</li> </ul>

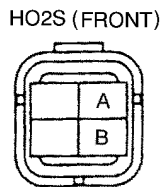
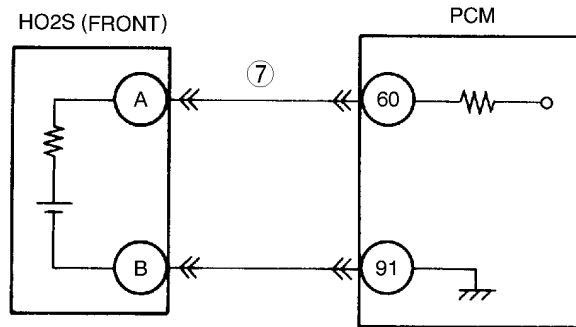

VEHICLE HARNESS SIDE CONNECTOR  
(VIEW FROM TERMINAL SIDE)

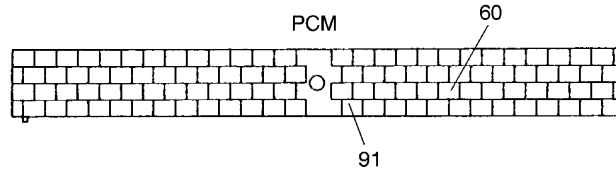

HARNESS SIDE CONNECTOR  
(VIEW FROM HARNESS SIDE)

**Diagnostic procedure**

STEP	INSPECTION		ACTION
1	<b>VERIFY FREEZE FRAME DATA HAS BEEN RECORDED</b> <ul style="list-style-type: none"> <li>• Has FREEZE FRAME DATA been recorded?</li> </ul>	Yes	Go to next step.
		No	Record FREEZE FRAME DATA on repair order, then go to next step.
2	<b>VERIFY RELATED REPAIR INFORMATION AVAILABILITY</b> <ul style="list-style-type: none"> <li>• Check for related Service Bulletins availability.</li> <li>• Is any related repair information available?</li> </ul>	Yes	Perform repair or diagnosis according to available repair information. <ul style="list-style-type: none"> <li>• If vehicle is not repaired, go to next step.</li> </ul>
		No	Go to next step.
3	<b>VERIFY RELATED PENDING AND STORED DTCS</b> <ul style="list-style-type: none"> <li>• Turn ignition key to OFF, then start engine.</li> <li>• Verify pending and stored DTCs using WDS or equivalent.</li> <li>• Is other DTC present except P0131 and P0132?</li> </ul>	Yes	Go to appropriate DTC troubleshooting procedures.
		No	Go to next step.

## ON-BOARD DIAGNOSTIC [ENGINE CONTROL SYSTEM (FS)]

STEP	INSPECTION	ACTION	
4	<b>IDENTIFY TRIGGER DTC FOR FREEZE FRAME DATA</b> <ul style="list-style-type: none"> <li>• Is DTC P0134 on FREEZE FRAME DATA?</li> </ul>	Yes	Go to next step.
		No	Go to troubleshooting procedures for DTC on FREEZE FRAME DATA. (See 01–02B–15 DTC TABLE [FS].)
5	<b>VERIFY CURRENT INPUT SIGNAL STATUS</b> <ul style="list-style-type: none"> <li>• Warm up engine.</li> <li>• Access O2S11 PID using WDS or equivalent.</li> <li>• Check PID under following accelerator pedal condition (in PARK).                             <ul style="list-style-type: none"> <li>— <b>More than 0.55 V</b> when suddenly depressing accelerator pedal (rich condition).</li> <li>— <b>Less than 0.55 V</b> just after release of accelerator pedal (lean condition)</li> </ul> </li> <li>• Is PID reading okay?</li> </ul>	Yes	Go to Step 8.
		No	Go to next step.
6	<b>INSPECT INSTALLATION OF HO2S</b> <ul style="list-style-type: none"> <li>• Check if HO2S (front) is loosely installed.</li> <li>• Is sensor installed securely?</li> </ul>	Yes	Go to next step.
		No	Install sensor securely, then go to Step 10.
7	<b>INSPECT EXHAUST SYSTEM FOR GAS LEAKAGE</b> <ul style="list-style-type: none"> <li>• Visually check if any gas leakage is found between exhaust manifold and HO2S (front).</li> <li>• Is there any gas leakage?</li> </ul>	Yes	Repair or replace any faulty exhaust parts, then go to Step 10.
		No	<ul style="list-style-type: none"> <li>• Inspect the following harnesses for open or short to ground circuit. Repair or replace harness if necessary.                             <ul style="list-style-type: none"> <li>— HO2S (front) terminal A (harness-side) to PCM terminal 60 (harness-side)                                     <ul style="list-style-type: none"> <li>• Repair or replace harness if necessary.</li> </ul> </li> </ul> </li> <li>• If all items above are okay, replace faulty sensor. Then go to Step 10.</li> </ul>
8	<b>INSPECT SEALING OF ENGINE COOLANT PASSAGE</b> <p><b>Warning</b></p> <ul style="list-style-type: none"> <li>• <b>Removing radiator cap when radiator is hot is dangerous. Scalding coolant and steam may shoot out and cause serious injury.</b></li> <li>• <b>When removing radiator cap, wrap a thick cloth around and turn it slowly.</b></li> </ul> <ul style="list-style-type: none"> <li>• Remove radiator cap.</li> <li>• Implement procedure to bleed air from engine coolant, then run engine at idle.</li> <li>• Is there any small bubble which makes engine coolant white at filling opening?</li> </ul> <p><b>Note</b></p> <ul style="list-style-type: none"> <li>• Large bubbles are normal since they are remaining air coming out from engine coolant passage.</li> </ul>	Yes	Air gets in from poor sealing on head gasket or other areas between combustion chamber and engine coolant passage. Repair or replace faulty parts, then go to Step 10.
		No	Go to next step.
9	<b>INSPECT ENGINE COMPRESSION</b> <ul style="list-style-type: none"> <li>• Inspect engine compression. (See 01–10B–8 COMPRESSION INSPECTION [FS].)</li> <li>• Is it okay?</li> </ul>	Yes	Go to next step.
		No	Implement engine overhaul for repairs, then go to next step.

# ON-BOARD DIAGNOSTIC [ENGINE CONTROL SYSTEM (FS)]

01-02B

STEP	INSPECTION		ACTION
10	<b>VERIFY TROUBLESHOOTING OF DTC P0134 COMPLETED</b> <ul style="list-style-type: none"> <li>Make sure to reconnect all disconnected connectors.</li> <li>Turn ignition key to ON (Engine OFF).</li> <li>Clear DTC from memory using WDS or equivalent.</li> <li>Start engine.</li> <li>Access RPM and ECT PIDs using WDS or equivalent.</li> <li>Verify that ECT PID is reading <b>above 70 °C {158 °F}</b>.</li> <li>Increase engine speed <b>above 1,500 rpm</b> (RPM PID reading) for <b>more than 120 seconds</b>.</li> <li>Is PENDING CODE of same DTC present?</li> </ul>	Yes	Replace PCM, then go to next step.
		No	Go to next step.
11	<b>VERIFY AFTER REPAIR PROCEDURE</b> <ul style="list-style-type: none"> <li>Perform "After Repair Procedure". (See 01-02B-9 AFTER REPAIR PROCEDURE [FS].)</li> <li>Is there any DTC present?</li> </ul>	Yes	Go to applicable DTC inspection. (See 01-02B-15 DTC TABLE [FS].)
		No	Troubleshooting completed.

## DTC P0138 [FS]

A3U010201084W25

DTC P0138	HO2S (rear) circuit high input
<b>DETECTION CONDITION</b>	<ul style="list-style-type: none"> <li>PCM monitors input voltage from HO2S (rear). If input voltage from sensor is <b>above 0.45 V for 6 seconds</b> during deceleration fuel cut, PCM determines that the circuit input is high.</li> </ul> <p><b>Diagnostic support note</b></p> <ul style="list-style-type: none"> <li>This is a continuous monitor (CCM).</li> <li>MIL illuminates if PCM detects the above malfunction condition in two consecutive drive cycles.</li> <li>PENDING CODE is available if PCM detects the above malfunction condition during first drive cycle.</li> <li>FREEZE FRAME DATA is available.</li> <li>DTC is stored in PCM memory.</li> </ul>
<b>POSSIBLE CAUSE</b>	<ul style="list-style-type: none"> <li>HO2S (rear) malfunction</li> <li>Short to power circuit in wiring between HO2S (rear) terminal A and PCM terminal 35</li> </ul>

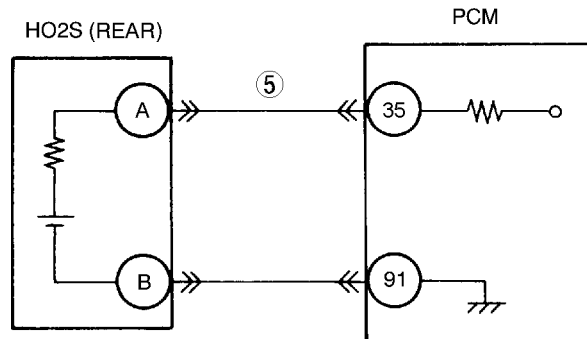

HO2S (REAR)

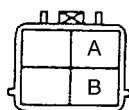

VEHICLE HARNESS SIDE CONNECTOR  
(VIEW FROM TERMINAL SIDE)

PCM

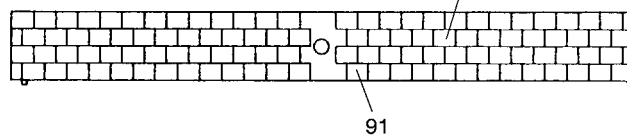

HARNESS SIDE CONNECTOR  
(VIEW FROM HARNESS SIDE)

## ON-BOARD DIAGNOSTIC [ENGINE CONTROL SYSTEM (FS)]

### Diagnostic procedure

STEP	INSPECTION	ACTION	
1	<b>VERIFY FREEZE FRAME DATA HAS BEEN RECORDED</b> <ul style="list-style-type: none"> <li>• Has FREEZE FRAME DATA been recorded?</li> </ul>	Yes	Go to next step.
		No	Record FREEZE FRAME DATA on repair order, then go to next step.
2	<b>VERIFY RELATED REPAIR INFORMATION AVAILABILITY</b> <ul style="list-style-type: none"> <li>• Check for related Service Bulletins availability.</li> <li>• Is any related repair information available?</li> </ul>	Yes	Perform repair or diagnosis according to available repair information. <ul style="list-style-type: none"> <li>• If vehicle is not repaired, go to next step.</li> </ul>
		No	Go to next step.
3	<b>VERIFY RELATED PENDING OR STORED DTCS</b> <ul style="list-style-type: none"> <li>• Turn ignition key to OFF, then Start engine.</li> <li>• Verify pending codes or stored DTCs using WDS or equivalent.</li> <li>• Is other DTC present?</li> </ul>	Yes	Go to appropriate DTC troubleshooting procedures. (See 01-02B-15 DTC TABLE [FS].)
		No	Go to next step.
4	<b>IDENTIFY TRIGGER DTC FOR FREEZE FRAME DATA</b> <ul style="list-style-type: none"> <li>• Is DTC P0138 on FREEZE FRAME DATA?</li> </ul>	Yes	Go to next step.
		No	Go to troubleshooting procedures for DTC on FREEZE FRAME DATA. (See 01-02B-15 DTC TABLE [FS].)
5	<b>INSPECT HO2S (REAR) SIGNAL CIRCUIT FOR SHORT TO POWER SUPPLY CIRCUIT</b> <ul style="list-style-type: none"> <li>• Turn ignition key to OFF.</li> <li>• Disconnect HO2S (rear) connector.</li> <li>• Turn ignition key to ON (Engine OFF).</li> <li>• Measure voltage between HO2S (rear) terminal A (harness-side) and body ground.</li> <li>• Is any voltage reading?</li> </ul>	Yes	Replace short to power supply circuit, then go to Step 7.
		No	Go to next step.
6	<b>VERIFY CURRENT INPUT SIGNAL STATUS</b> <ul style="list-style-type: none"> <li>• Start engine.</li> <li>• Access O2S12 PID using WDS or equivalent.</li> <li>• Verify PID while racing engine at least <b>10 times</b> (in neutral position).</li> <li>• Does PID reading stay <b>above 0.45 V</b>?</li> </ul>	Yes	Replace HO2S (rear), then go to next step.
		No	Go to next step.
7	<b>VERIFY TROUBLESHOOTING OF DTC P0138 COMPLETED</b> <ul style="list-style-type: none"> <li>• Make sure to reconnect all disconnected connectors.</li> <li>• Turn ignition key to ON (Engine OFF).</li> <li>• Clear DTC from memory using WDS or equivalent.</li> <li>• Run OBD-II DRIVE MODE 1 and 3.</li> <li>• Is PENDING CODE of same DTC present?</li> </ul>	Yes	Replace PCM, then go to next step.
		No	Go to next step.
8	<b>VERIFY AFTER REPAIR PROCEDURE</b> <ul style="list-style-type: none"> <li>• Perform "After Repair Procedure". (See 01-02B-9 AFTER REPAIR PROCEDURE [FS].)</li> <li>• Is there any DTC present?</li> </ul>	Yes	Go to applicable DTC inspection. (See 01-02B-15 DTC TABLE [FS].)
		No	Troubleshooting completed.

### DTC P0140 [FS]

A3U010201084W26

DTC P0140	HO2S (rear) circuit no activity detected
<b>DETECTION CONDITION</b>	<ul style="list-style-type: none"> <li>• PCM monitors input voltage from HO2S (rear) when the following monitoring conditions are met. If input voltage from sensor never <b>exceed 0.55 V</b> for <b>30 seconds</b>, PCM determines that sensor circuit is not activated.</li> </ul> <p><b>MONITORING CONDITIONS</b></p> <ul style="list-style-type: none"> <li>— Drive mode 3</li> <li>— Following conditions are met: <ul style="list-style-type: none"> <li>• Engine speed is <b>above 1,500 rpm</b>.</li> <li>• Engine coolant temperature is <b>above 70 °C {158 °F}</b>.</li> </ul> </li> </ul> <p><b>Diagnostic support note</b></p> <ul style="list-style-type: none"> <li>• This is a continuous monitor (CCM).</li> <li>• MIL illuminates if PCM detects the above malfunction condition in two consecutive drive cycles.</li> <li>• PENDING CODE is available if PCM detects the above malfunction condition during first drive cycle.</li> <li>• FREEZE FRAME DATA is available.</li> <li>• DTC is stored in PCM memory.</li> </ul>



# ON-BOARD DIAGNOSTIC [ENGINE CONTROL SYSTEM (FS)]

01-02B

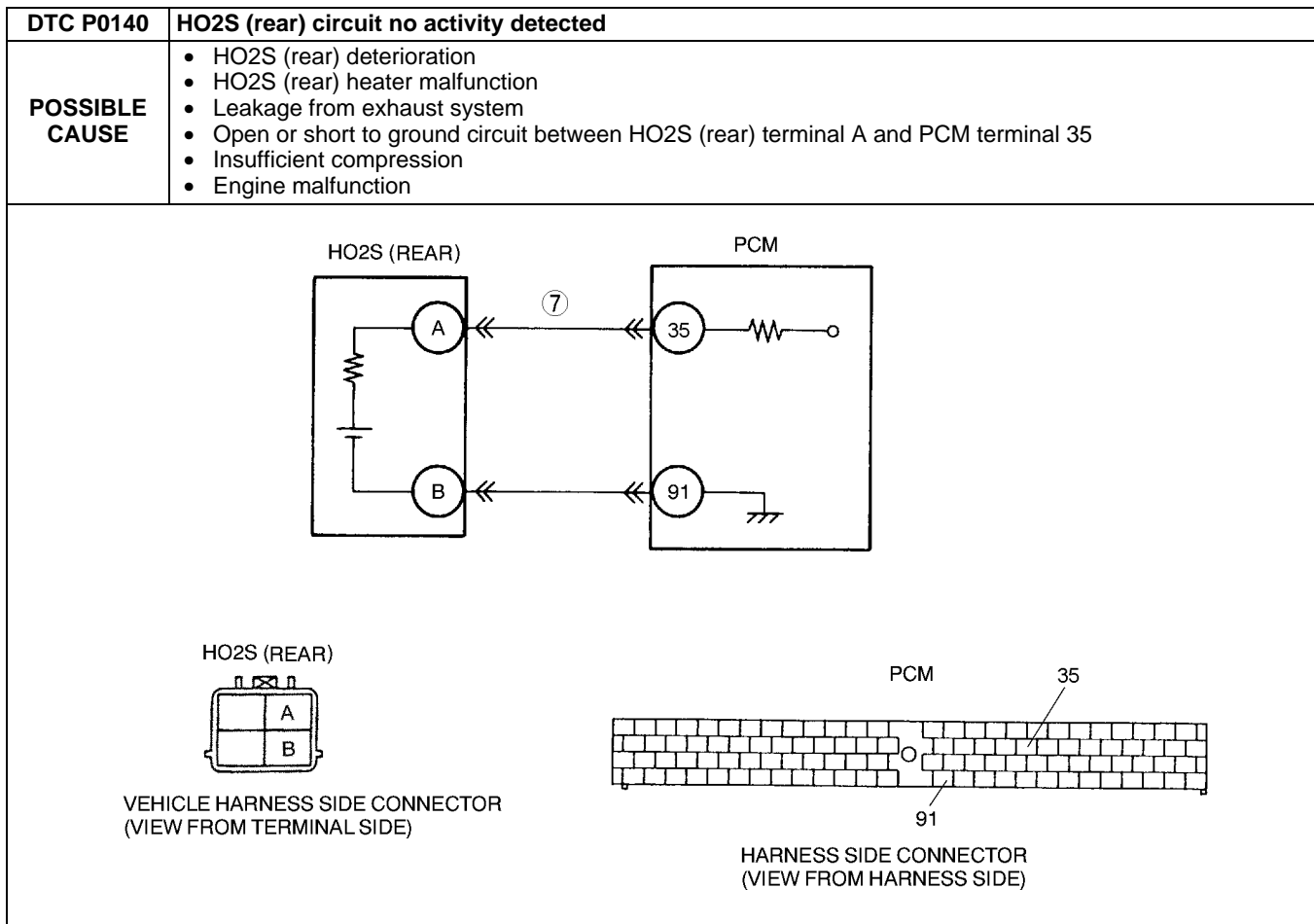

### Diagnostic procedure

STEP	INSPECTION		ACTION
1	<b>VERIFY FREEZE FRAME DATA HAS BEEN RECORDED</b> • Has FREEZE FRAME DATA been recorded?	Yes	Go to next step.
		No	Record FREEZE FRAME DATA on repair order, then go to next step.
2	<b>VERIFY RELATED REPAIR INFORMATION AVAILABILITY</b> • Check for related Service Bulletins availability. • Is any related repair information available?	Yes	Perform repair or diagnosis according to available repair information. • If vehicle is not repaired, go to next step.
		No	Go to next step.
3	<b>VERIFY RELATED PENDING AND STORED DTCS</b> • Turn ignition key to OFF, then start engine. • Verify pending and stored DTCs using WDS or equivalent. • Is other DTC present except P0131 and P0132?	Yes	Go to appropriate DTC troubleshooting procedures. (See 01-02B-15 DTC TABLE [FS].)
		No	Go to next step.
4	<b>IDENTIFY TRIGGER DTC FOR FREEZE FRAME DATA</b> • Is DTC P0140 on FREEZE FRAME DATA?	Yes	Go to next step.
		No	Go to troubleshooting procedures for DTC on FREEZE FRAME DATA. (See 01-02B-15 DTC TABLE [FS].)
5	<b>VERIFY CURRENT INPUT SIGNAL STATUS</b> • Warm up engine. • Access O2S12 PID using WDS or equivalent. • Verify PID while racing engine at least <b>10 times</b> (in neutral position). • Is PID reading okay? — <b>More than 0.55 V</b> at least once during engine racing.	Yes	Go to Step 8.
		No	Go to next step.
6	<b>INSPECT INSTALLATION OF HO2S (REAR)</b> • Check if HO2S (rear) is loosely installed. • Is sensor installed securely?	Yes	Go to next step.
		No	Install sensor securely, then go to Step 10.

## ON-BOARD DIAGNOSTIC [ENGINE CONTROL SYSTEM (FS)]

STEP	INSPECTION	ACTION	
7	<b>INSPECT EXHAUST SYSTEM FOR GAS LEAKAGE</b> <ul style="list-style-type: none"> <li>• Visually check if any gas leakage is found between exhaust pipe and HO2S (rear).</li> <li>• Is there any gas leakage?</li> </ul>	Yes	Repair or replace any faulty exhaust parts, then go to Step 10.
		No	<ul style="list-style-type: none"> <li>• Inspect for open or short to ground circuit between HO2S (rear) terminal A (harness-side) and PCM terminal 35 (harness-side).                             <ul style="list-style-type: none"> <li>— Repair or replace harness if necessary.</li> </ul> </li> <li>• If all items above are okay, replace HO2S (rear). Then go to Step 10.</li> </ul>
8	<b>INSPECT SEALING OF ENGINE COOLANT PASSAGE</b> <p><b>Warning</b></p> <ul style="list-style-type: none"> <li>• <b>Removing radiator cap when radiator is hot is dangerous. Scalding coolant and steam may shoot out and cause serious injury.</b></li> <li>• <b>When removing radiator cap, wrap a thick cloth around and turn it slowly.</b></li> </ul> <ul style="list-style-type: none"> <li>• Remove radiator cap.</li> <li>• Implement procedure to bleed air from engine coolant, then run engine at idle.</li> <li>• Is there any small bubble which makes engine coolant white at filling opening?</li> </ul> <p><b>Note</b></p> <ul style="list-style-type: none"> <li>• Large bubbles are normal since they are remaining air coming out from engine coolant passage.</li> </ul>	Yes	Air gets in from poor sealing on head gasket or other areas between combustion chamber and engine coolant passage. Repair or replace faulty parts, then go to Step 10.
		No	Go to next step.
9	<b>INSPECT ENGINE COMPRESSION</b> <ul style="list-style-type: none"> <li>• Inspect engine compression. (See 01-10B-8 COMPRESSION INSPECTION [FS].)</li> <li>• Is it okay?</li> </ul>	Yes	Go to next step.
		No	Implement engine overhaul for repairs, then go to next step.
10	<b>VERIFY TROUBLESHOOTING OF DTC P0140 COMPLETED</b> <ul style="list-style-type: none"> <li>• Make sure to reconnect all disconnected connectors.</li> <li>• Turn ignition key to ON (Engine OFF).</li> <li>• Clear DTC from memory using WDS or equivalent.</li> <li>• Access RPM and ECT PIDs using WDS or equivalent.</li> <li>• Verify that ECT PID is reading <b>above 70 °C {158 °F}</b>.</li> <li>• Increase engine speed <b>above 1,500 rpm</b> (RPM PID reading) for <b>more than 30 seconds</b>.</li> <li>• Is PENDING CODE of same DTC present?</li> </ul>	Yes	Replace PCM, then go to next step.
		No	Go to next step.
11	<b>VERIFY AFTER REPAIR PROCEDURE</b> <ul style="list-style-type: none"> <li>• Perform "After Repair Procedure". (See 01-02B-9 AFTER REPAIR PROCEDURE [FS].)</li> <li>• Is there any DTC present?</li> </ul>	Yes	Go to applicable DTC inspection. (See 01-02B-15 DTC TABLE [FS].)
		No	Troubleshooting completed.

# ON-BOARD DIAGNOSTIC [ENGINE CONTROL SYSTEM (FS)]

DTC P0171 [FS]

A3U010201084W27

01-02B

<b>DTC P0171</b>	<b>Fuel trim system too lean</b>
<b>DETECTION CONDITION</b>	<ul style="list-style-type: none"> <li>PCM monitors short term fuel trim (SHRTFT) and long term fuel trim (LONGFT) values when DRIVE MODE 1 is run. If fuel trim exceeds preprogrammed criteria, PCM determines that the fuel system is too lean.</li> </ul> <p><b>Diagnostic support note</b></p> <ul style="list-style-type: none"> <li>This is a continuous monitor. (FUEL SYSTEM)</li> <li>MIL illuminates if PCM detects the above malfunction conditions in two consecutive drive cycles.</li> <li>PENDING CODE is available if PCM detects the above malfunction conditions during first drive cycle.</li> <li>FREEZE FRAME DATA is available.</li> <li>DTC is stored in PCM memory.</li> </ul>
<b>POSSIBLE CAUSE</b>	<ul style="list-style-type: none"> <li>Misfire</li> <li>HO2S (front) deterioration</li> <li>HO2S (front) heater malfunction</li> <li>PRC solenoid valve malfunction</li> <li>Pressure regulator malfunction</li> <li>Fuel pump malfunction</li> <li>Fuel filter clogged or restricted</li> <li>Fuel leakage on fuel line from fuel delivery pipe and fuel pump</li> <li>Fuel return hose clogged</li> <li>Leakage from exhaust system</li> <li>Purge solenoid valve malfunction</li> <li>Purge solenoid hoses improper connection</li> <li>Insufficient compression</li> </ul>

**Diagnostic procedure**

STEP	INSPECTION		ACTION
1	<b>VERIFY FREEZE FRAME DATA HAS BEEN RECORDED</b> <ul style="list-style-type: none"> <li>Has FREEZE FRAME DATA been recorded?</li> </ul>	Yes	Go to next step.
		No	Record FREEZE FRAME DATA on repair order, then go to next step.
2	<b>VERIFY RELATED REPAIR INFORMATION AVAILABILITY</b> <ul style="list-style-type: none"> <li>Check for related Service Bulletins availability.</li> <li>Is any related repair information available?</li> </ul>	Yes	Perform repair or diagnosis according to available repair information. <ul style="list-style-type: none"> <li>If vehicle is not repaired, go to next step.</li> </ul>
		No	Go to next step.
3	<b>VERIFY RELATED PENDING CODE OR STORED DTCS</b> <ul style="list-style-type: none"> <li>Turn ignition key to OFF, then start engine.</li> <li>Verify related PENDING CODE or stored DTCS.</li> <li>Are other DTCS present?</li> </ul>	Yes	If misfire DTC is present, go to Step 8. If other DTC is present, go to appropriate DTC troubleshooting procedures. (See 01-02B-15 DTC TABLE [FS].)
		No	If drivability concern is present, go to Step 8. If not, go to next step.
4	<b>IDENTIFY TRIGGER DTC FOR FREEZE FRAME DATA</b> <ul style="list-style-type: none"> <li>Is DTC P0171 on FREEZE FRAME DATA?</li> </ul>	Yes	Go to next step.
		No	Go to troubleshooting procedures for DTC on FREEZE FRAME DATA.
5	<b>VERIFY CURRENT INPUT SIGNAL STATUS (IGNITION KEY TO ON/IDLE)</b> <ul style="list-style-type: none"> <li>Access ECT, MAF, TP and VS PIDs using WDS or equivalent. (See 01-40B-8 PID/DATA MONITOR table (Reference).)</li> <li>Is there any signal that is far out of specification when ignition key is ON and engine runs?</li> </ul>	Yes	Inspect suspected sensor and excessive resistance in related wiring harnesses. Repair or replace if necessary. Then go to Step 20.
		No	Go to next step.
6	<b>VERIFY CURRENT INPUT SIGNAL STATUS UNDER TROUBLE CONDITION</b> <ul style="list-style-type: none"> <li>Inspect same PIDs as Step 5 while simulating FREEZE FRAME DATA condition.</li> <li>Is there any input signal which causes drastic changes?</li> </ul>	Yes	Inspect suspected sensor and related wiring harnesses, and repair or replace it. Then go to Step 20.
		No	Go to next step.

## ON-BOARD DIAGNOSTIC [ENGINE CONTROL SYSTEM (FS)]

STEP	INSPECTION	ACTION
7	<b>VERIFY CURRENT INPUT SIGNAL STATUS OF HO2S FRONT</b> <ul style="list-style-type: none"> <li>• Access O2S11 PID using WDS or equivalent.</li> <li>• Check PID under following accelerator pedal condition. (in PARK)                             <ul style="list-style-type: none"> <li>— <b>More than 0.45 V</b> when suddenly depressing accelerator pedal (rich condition)</li> <li>— <b>Less than 0.45 V</b> just after release of accelerator pedal (lean condition)</li> </ul> </li> <li>• Is PID reading okay?</li> </ul>	Yes Inspect following for air suction due to cracks, damages and loose parts: <ul style="list-style-type: none"> <li>• From air cleaner to throttle body</li> <li>• From throttle body to dynamic chamber</li> <li>• From dynamic chamber to intake manifold</li> <li>• Vacuum hoses</li> </ul> <p style="margin-left: 20px;"><b>Note</b></p> <ul style="list-style-type: none"> <li>• Engine speed may change when rust penetrating agent is sprayed on the air suction area.</li> </ul> Repair or replace any faulty part, then go to Step 20.
		No Visually inspect for any gas leakage between exhaust manifold and HO2S (front). <ul style="list-style-type: none"> <li>• If there is no leakage, replace HO2S (front).</li> </ul> Then go to Step 20.
8	<b>INSPECT MAF SIGNAL</b> <ul style="list-style-type: none"> <li>• Start engine.</li> <li>• Access MAF PID using WDS or equivalent.</li> <li>• Verify that MAF PID changes quickly according to race engine RPM.</li> <li>• Is MAF PID response okay?</li> </ul>	Yes Go to next step.
		No Replace MAF sensor, then go to Step 20.
9	<b>INSPECT FOR EXCESSIVE AIR SUCTION OF INTAKE-AIR SYSTEM</b> <ul style="list-style-type: none"> <li>• Visually inspect for loose, cracked or damaged hoses on intake-air system.</li> <li>• Is there malfunction?</li> </ul>	Yes Repair or replace source of air suction, then go to Step 20.
		No Go to next step.
10	<b>INSPECT FUEL LINE PRESSURE</b> <ul style="list-style-type: none"> <li>• Turn ignition key to OFF.</li> </ul> <p style="margin-left: 20px;"><b>Note</b></p> <ul style="list-style-type: none"> <li>• If engine will not start, inspect fuel line pressure with ignition key ON.</li> </ul> <ul style="list-style-type: none"> <li>• Inspect fuel line pressure while engine running. (See 01-14-6 FUEL PRESSURE INSPECTION.)</li> <li>• Is fuel line pressure <b>within 210—250 kPa {2.1—2.6 kgf/cm<sup>2</sup>, 30—36 psi}</b>?</li> </ul>	Yes Go to Step 14.
		No If fuel line pressure is too high: Go to next step. If fuel line pressure is too low: Go to Step 12.
11	<b>VERIFY VACUUM IS LEADING TO PRESSURE REGULATOR</b> <ul style="list-style-type: none"> <li>• Disconnect vacuum hose from pressure regulator.</li> <li>• Verify that vacuum is felt at opening port of disconnected vacuum hose.</li> <li>• Is vacuum felt?</li> </ul>	Yes Inspect fuel pump maximum pressure and fuel return hose for clogging. <ul style="list-style-type: none"> <li>• If any problem is found, repair or replace suspected parts.</li> <li>• If all items above are okay, replace pressure regulator.</li> </ul> Then go to Step 20.
		No Verify vacuum hoses are connected correctly. <ul style="list-style-type: none"> <li>• If okay, replace PRC solenoid valve, then go to Step 20.</li> <li>• If not, reconnect vacuum hoses to correct position, then go to Step 20.</li> </ul>
12	<b>INSPECT FUEL PUMP MAXIMUM PRESSURE</b> <ul style="list-style-type: none"> <li>• Perform fuel pump maximum pressure test. (See 01-14-15 FUEL PUMP UNIT INSPECTION.)</li> <li>• Is fuel pump maximum pressure <b>within 450—630 kPa {4.5—6.5 kgf/cm<sup>2</sup>, 64—92 psi}</b>?</li> </ul>	Yes Go to next step.
		No Inspect fuel pump circuit for open or poor connection. Repair or replace suspected circuit, then go to Step 20. <ul style="list-style-type: none"> <li>• If circuit is okay, replace fuel pump. Then go to Step 20.</li> </ul>

## ON-BOARD DIAGNOSTIC [ENGINE CONTROL SYSTEM (FS)]

STEP	INSPECTION	ACTION	
13	<b>INSPECT FUEL LINE FROM FUEL PUMP TO FUEL DELIVERY PIPE</b> <ul style="list-style-type: none"> <li>• Visually inspect fuel line for any leakage.</li> <li>• Is any fuel leakage found?</li> </ul>	Yes	Replace suspected fuel line, then go to Step 20.
		No	Inspect fuel filters for following: <ul style="list-style-type: none"> <li>• Restriction or clogging at fuel filter (high-pressure).</li> <li>• Foreign materials or stain inside fuel filter (low-pressure)</li> </ul> Perform following actions as result. <ul style="list-style-type: none"> <li>• If restriction or clogging is found at fuel filter (high-pressure), replace fuel filter (high-pressure).</li> <li>• If foreign materials or stain is found inside fuel filter (low-pressure), clean of fuel tank and fuel filter (low-pressure).</li> <li>• If all items above are okay, replace pressure regulator. Then go to Step 20.</li> </ul>
14	<b>CHECK IGNITION COIL OPERATION AND HIGH-TENSION LEAD WITH TIMING LIGHT</b> <ul style="list-style-type: none"> <li>• Verify blinking condition on each cylinders using timing light at idle.</li> <li>• Do all cylinders show blinking condition?</li> </ul>	Yes	Go to Step 18.
		No	Go to next step.
15	<b>CHECK HIGH-TENSION LEADS OF NO BLINKING CYLINDER</b> <ul style="list-style-type: none"> <li>• Turn ignition key to OFF.</li> <li>• Inspect high-tension leads for installation condition, corrosion on terminal, open lead and damaged cover.</li> <li>• Is condition of high-tension lead okay?</li> </ul>	Yes	Go to next step.
		No	Replace faulty high-tension lead, then go to Step 20.
16	<b>INSPECT POWER SUPPLY TERMINAL AT IGNITION COIL CONNECTOR</b> <ul style="list-style-type: none"> <li>• Disconnect ignition coil connector.</li> <li>• Turn ignition key to ON (Engine OFF).</li> <li>• Check voltage at ignition coil connector terminal D (harness-side) and body ground.</li> <li>• Is voltage reading <b>B+</b>?</li> </ul>	Yes	Go to next step.
		No	Check for open circuit between ignition coil connector and ignition switch. Repair or replace wiring harness, then go to Step 20.
17	<b>INSPECT IGNITION COIL RESISTANCE</b> <ul style="list-style-type: none"> <li>• Check ignition coil resistance. (See 01-18-2 IGNITION COIL INSPECTION.)</li> <li>• Is coil resistance okay?</li> </ul>	Yes	Go to next step.
		No	Replace ignition coil, then go to Step 20.
18	<b>INSPECT ENGINE COMPRESSION</b> <ul style="list-style-type: none"> <li>• Inspect engine compression. (See 01-10B-8 COMPRESSION INSPECTION [FS].)</li> <li>• Is it okay?</li> </ul>	Yes	Go to next step.
		No	Implement engine overhaul for repairs, then go to Step 20.
19	<b>INSPECT FUEL INJECTOR OPERATION</b> <ul style="list-style-type: none"> <li>• Remove fuel injector from suspected bank. (See 01-14-24 FUEL INJECTOR INSPECTION.)</li> <li>• Inspect injector operation.</li> <li>• Is fuel injector okay?</li> </ul>	Yes	Go to next step.
		No	Replace injector, then go to Step 20.
20	<b>VERIFY TROUBLESHOOTING OF DTC P0171 COMPLETED</b> <ul style="list-style-type: none"> <li>• Make sure to reconnect all disconnected connectors.</li> <li>• Clear DTC from memory using WDS or equivalent.</li> <li>• Run OBD-II DRIVE MODE 1, 2 and 3.</li> <li>• Is PENDING CODE P0171 present?</li> </ul>	Yes	Replace PCM, then go to next step.
		No	Go to next step.
21	<b>VERIFY AFTER REPAIR PROCEDURE</b> <ul style="list-style-type: none"> <li>• Perform "After Repair Procedure". (See 01-02B-9 AFTER REPAIR PROCEDURE [FS].)</li> <li>• Is there any DTC present?</li> </ul>	Yes	Go to applicable DTC inspection. (See 01-02B-15 DTC TABLE [FS].)
		No	Troubleshooting completed.

01-02B

# ON-BOARD DIAGNOSTIC [ENGINE CONTROL SYSTEM (FS)]

DTC P0172 [FS]

A3U010201084W28

<b>DTC P0172</b>	<b>Fuel trim system (RH) too rich</b>
<b>DETECTION CONDITION</b>	<ul style="list-style-type: none"> <li>• PCM monitors short term fuel trim (SHRTFT) and long term fuel trim (LONGFT) values when DRIVE MODE 1 is run. If fuel trim exceeds pre programmed criteria, PCM determines that the fuel system is too rich.</li> </ul> <p><b>Diagnostic support note</b></p> <ul style="list-style-type: none"> <li>• This is a continuous monitor. (FUEL SYSTEM)</li> <li>• MIL illuminates if PCM detects the above malfunction conditions in two consecutive drive cycles.</li> <li>• PENDING CODE is available if PCM detects the above malfunction condition during first drive cycle.</li> <li>• FREEZE FRAME DATA is available.</li> <li>• DTC is stored in PCM memory.</li> </ul>
<b>POSSIBLE CAUSE</b>	<ul style="list-style-type: none"> <li>• Misfire</li> <li>• HO2S (front) deterioration</li> <li>• HO2S heater (front) malfunction</li> <li>• PRC solenoid valve malfunction</li> <li>• Pressure regulator malfunction</li> <li>• Fuel pump malfunction</li> <li>• Fuel return hose clogged</li> <li>• Purge solenoid valve malfunction</li> <li>• Purge solenoid hoses improper connection</li> <li>• PCV valve malfunction</li> </ul>

## Diagnostic procedure

STEP	INSPECTION		ACTION
1	<b>VERIFY FREEZE FRAME DATA HAS BEEN RECORDED</b> • Has FREEZE FRAME DATA been recorded?	Yes	Go to next step.
		No	Record FREEZE FRAME DATA on repair order, then go to next step.
2	<b>VERIFY RELATED REPAIR INFORMATION AVAILABILITY</b> • Check for related Service Bulletins availability. • Is any related repair information available?	Yes	Perform repair or diagnosis according to available repair information. • If vehicle is not repaired, go to next step.
		No	Go to next step.
3	<b>VERIFY RELATED PENDING CODE OR STORED DTCS</b> • Turn ignition key to OFF, then start engine. • Verify related pending code or stored DTCs. • Are other DTCs present?	Yes	Go to appropriate DTC troubleshooting procedures.
		No	If drivability concern or rough idle is present, go to Step 10. If not, go to next step.
4	<b>IDENTIFY TRIGGER DTC FOR FREEZE FRAME DATA</b> • Is DTC P0172 on FREEZE FRAME DATA?	Yes	Go to next step.
		No	Go to troubleshooting procedures for DTC on FREEZE FRAME DATA.
5	<b>VERIFY CURRENT INPUT SIGNAL STATUS (IGNITION KEY TO ON/IDLE)</b> • Access ECT, MAF, TP and VS PIDs using WDS or equivalent. (See 01-40B-8 PID/DATA MONITOR table (Reference).) • Is there any signal that is far out of specification when ignition key is ON and engine runs?	Yes	Inspect suspected sensor and excessive resistance in related wiring harnesses. Repair or replace if necessary. Then go to Step 12.
		No	Go to next step.
6	<b>VERIFY CURRENT INPUT SIGNAL STATUS UNDER TROUBLE CONDITION</b> • Inspect same PIDs as in Step 5 while simulating FREEZE FRAME DATA condition. • Is there any input signal which causes drastic changes?	Yes	Inspect suspected sensor and related wiring harnesses, and repair or replace it. Then go to Step 12.
		No	Go to next step.
7	<b>VERIFY CURRENT INPUT SIGNAL STATUS OF HO2S (FRONT)</b> • Access O2S11 PID using WDS or equivalent. • Check PID under following accelerator pedal condition (in PARK or NEUTRAL). — <b>More than 0.45 V</b> when suddenly depressing accelerator pedal (rich condition) — <b>Less than 0.45 V</b> just after release of accelerator pedal (lean condition) • Is PID reading okay?	Yes	Go to next step.
		No	Replace suspected HO2S (front). Then go to Step 12.

## ON-BOARD DIAGNOSTIC [ENGINE CONTROL SYSTEM (FS)]

STEP	INSPECTION	ACTION	
8	<b>INSPECT FUEL LINE PRESSURE</b> <ul style="list-style-type: none"> <li>• Turn ignition key to OFF.</li> <li>• Inspect fuel line pressure while engine running. (See 01–14–6 FUEL PRESSURE INSPECTION.)</li> <li>• Is fuel line pressure <b>within 210—250 kPa {2.1—2.6 kgf/cm<sup>2</sup>, 30—36 psi}</b>?</li> </ul>	Yes	Go to Step 10.
		No	Go to next step.
9	<b>VERIFY VACUUM IS LEADING TO PRESSURE REGULATOR</b> <ul style="list-style-type: none"> <li>• Start engine.</li> <li>• Disconnect vacuum hose from pressure regulator.</li> <li>• Verify that the vacuum is felt at opening port of disconnected vacuum hose.</li> <li>• Is vacuum felt?</li> </ul>	Yes	Inspect fuel pump maximum pressure and fuel return hose for clogging. <ul style="list-style-type: none"> <li>• If any problem found, repair or replace suspected parts.</li> <li>• If all items above are okay, replace pressure regulator. Then go to Step 12.</li> </ul>
		No	Verify vacuum hoses are connected correctly. <ul style="list-style-type: none"> <li>• If okay, replace PRC solenoid valve, then go to Step 12.</li> <li>• If not, reconnect vacuum hoses to correct position, then go to Step 12.</li> </ul>
10	<b>INSPECT PURGE SOLENOID VALVE FOR WHETHER STUCK OPEN</b> <ul style="list-style-type: none"> <li>• Turn ignition key to OFF.</li> <li>• Disconnect both hoses from purge solenoid valve.</li> <li>• Blow air through purge solenoid valve.</li> <li>• Does air blow through?</li> </ul>	Yes	Replace purge solenoid valve. Then go to Step 12.
		No	Go to next step.
11	<b>INSPECT PCV VALVE OPERATION</b> <ul style="list-style-type: none"> <li>• Inspect PCV valve operation. (See 01–03B–58 Pressure Regulator Control Inspection.)</li> <li>• Is PCV valve okay?</li> </ul>	Yes	Go to next step.
		No	Replace PCV valve, then go to next step.
12	<b>VERIFY TROUBLESHOOTING OF DTC P0172 COMPLETED</b> <ul style="list-style-type: none"> <li>• Make sure to reconnect all disconnected connectors.</li> <li>• Turn ignition key to ON (Engine OFF).</li> <li>• Clear DTC from memory using WDS or equivalent.</li> <li>• Run OBD-II DRIVE MODE 1, 2 and 3.</li> <li>• Is PENDING CODE of same DTC present?</li> </ul>	Yes	Replace PCM, then go to next step.
		No	Go to next step.
13	<b>VERIFY AFTER REPAIR PROCEDURE</b> <ul style="list-style-type: none"> <li>• Perform “After Repair Procedure”. (See 01–02B–9 AFTER REPAIR PROCEDURE [FS].)</li> <li>• Is there any DTC present?</li> </ul>	Yes	Go to applicable DTC inspection. (See 01–02B–15 DTC TABLE [FS].)
		No	Troubleshooting completed.

01–02B

### DTC P0300 [FS]

A3U010201085W01

DTC P0300	Random misfire detection
<b>DETECTION CONDITION</b>	<ul style="list-style-type: none"> <li>• PCM monitors CKP sensor input signal interval time. PCM calculates the change of the interval time for each cylinder. If the change of interval time exceeds the preprogrammed criteria, PCM detects a misfire in the corresponding cylinder. While the engine is running, PCM counts the number of misfires that occurred at <b>200 crankshaft revolutions</b> and <b>1,000 crankshaft revolutions</b> and calculates misfire ratio for each crankshaft revolution. If the ratio exceeds the preprogrammed criteria, PCM determines that a misfire, which can damage the catalytic converter or affect emission performance, has occurred.</li> </ul> <p><b>Diagnostic support note</b></p> <ul style="list-style-type: none"> <li>• This is a continuous monitor (MISFIRE).</li> <li>• MIL illuminates if PCM detects the misfire which affects emission performance in two consecutive drive cycles.</li> <li>• PENDING CODE is available if PCM detects the misfire which affects emission performance during first drive cycle.</li> <li>• MIL flashes if PCM detects the misfire which can damage the catalytic converter during first drive cycle. Therefore, PENDING CODE is not available while MIL flashes.</li> <li>• FREEZE FRAME DATA is available.</li> <li>• DTC is stored in PCM memory.</li> </ul>

## ON-BOARD DIAGNOSTIC [ENGINE CONTROL SYSTEM (FS)]

<b>DTC P0300</b>	<b>Random misfire detection</b>
<b>POSSIBLE CAUSE</b>	<ul style="list-style-type: none"> <li>• CKP sensor malfunction</li> <li>• CMP sensor malfunction</li> <li>• Ignition coil malfunction</li> <li>• High-tension lead malfunction</li> <li>• MAF sensor contamination</li> <li>• Excess air suction in intake-air system (between MAF sensor and dynamic chamber)</li> <li>• Fuel pump malfunction</li> <li>• Fuel pressure regulator malfunction</li> <li>• Fuel line clogged</li> <li>• Fuel filter clogged</li> <li>• Fuel leakage in fuel line</li> <li>• Purge control solenoid valve malfunction</li> <li>• PCV valve malfunction</li> <li>• EGR valve malfunction</li> <li>• Vacuum hoses damages or improper connection</li> <li>• Related connector and terminal malfunction</li> <li>• Related wiring harness malfunction</li> <li>• Poor fuel quality</li> </ul>

### Diagnostic procedure

STEP	INSPECTION		ACTION
1	<b>VERIFY FREEZE FRAME DATA HAS BEEN RECORDED</b> <ul style="list-style-type: none"> <li>• Has FREEZE FRAME DATA been recorded?</li> </ul>	Yes	Go to next step.
		No	Record FREEZE FRAME DATA on repair order, then go to next step.
2	<b>VERIFY RELATED REPAIR INFORMATION AVAILABILITY</b> <ul style="list-style-type: none"> <li>• Check for related Service Bulletins availability.</li> <li>• Is any related repair information available?</li> </ul>	Yes	Perform repair or diagnosis according to available repair information. <ul style="list-style-type: none"> <li>• If vehicle is not repaired, go to next step.</li> </ul>
		No	Go to next step.
3	<b>VERIFY RELATED PENDING CODE OR STORED DTCs</b> <ul style="list-style-type: none"> <li>• Turn ignition key to OFF then start engine.</li> <li>• Verify related pending code or stored DTCs.</li> <li>• Are other DTCs present?</li> </ul>	Yes	Go to appropriate DTC troubleshooting. (See 01–02B–15 DTC TABLE [FS].)
		No	Go to next step.
4	<b>VERIFY CURRENT INPUT SIGNAL STATUS (IGNITION KEY TO ON/IDLE)</b> <ul style="list-style-type: none"> <li>• Access ECT, IAT, MAF, RPM, TP, and VS PIDs using WDS or equivalent. (See 01–40B–7 PCM Inspection Using the SST (WDS or equivalent).)</li> <li>• Is there any signal that is far out of specification when ignition switch is ON and engine runs at idle?</li> </ul>	Yes	Inspect suspected circuit and/or part according to inspection results. (See 01–40B–7 PCM Inspection Using the SST (WDS or equivalent).) Then go to Step 23.
		No	Go to next step.
5	<b>VERIFY CURRENT INPUT SIGNAL STATUS UNDER TROUBLE CONDITION</b> <ul style="list-style-type: none"> <li>• Inspect same PIDs as in Step 4 while simulating FREEZE FRAME DATA condition.</li> <li>• Is there any signal which causes drastic changes?</li> </ul>	Yes	Inspect suspected circuit and/or part according to inspection results. (See 01–40B–7 PCM Inspection Using the SST (WDS or equivalent).) Then go to Step 23.
		No	Go to next step.
6	<b>INSPECT CMP SENSOR</b> <ul style="list-style-type: none"> <li>• Inspect CMP sensor. (See 01–40B–35 CAMSHAFT POSITION (CMP) SENSOR INSPECTION [FS].)</li> <li>• Is CMP sensor okay?</li> </ul>	Yes	Go to next step.
		No	Inspect installation condition and damages on timing belt and gears, repair faulty parts. <ul style="list-style-type: none"> <li>• If it is okay, replace CMP sensor.</li> </ul> Then go to Step 23.
7	<b>VERIFY CKP SENSOR INSTALLATION CONDITION</b> <ul style="list-style-type: none"> <li>• Check CKP sensor for looseness.</li> <li>• Is CKP sensor loose?</li> </ul>	Yes	Retighten CKP sensor, then go to Step 23.
		No	Go to next step.
8	<b>CHECK IGNITION COIL OPERATION AND HIGH-TENSION LEAD WITH TIMING LIGHT</b> <ul style="list-style-type: none"> <li>• Verify blinking condition on each cylinders using timing light at idle.</li> <li>• Do all cylinders show blinking condition?</li> </ul>	Yes	Go to Step 12.
		No	Go to next step.



## ON-BOARD DIAGNOSTIC [ENGINE CONTROL SYSTEM (FS)]

STEP	INSPECTION	ACTION	
9	<b>CHECK HIGH-TENSION LEADS OF NON-BLINKING CYLINDER</b> <ul style="list-style-type: none"> <li>• Turn ignition key to OFF.</li> <li>• Inspect high-tension leads for installation condition, corrosion on terminal, open lead and damaged cover.</li> <li>• Is condition of high-tension lead okay?</li> </ul>	Yes	Go to next step.
		No	Replace faulty high-tension lead, then go to Step 23.
10	<b>INSPECT POWER SUPPLY TERMINAL AT IGNITION COIL CONNECTOR</b> <ul style="list-style-type: none"> <li>• Disconnect ignition coil connector.</li> <li>• Turn ignition key to ON (Engine OFF).</li> <li>• Measure voltage between ignition coil terminal A (harness-side) and body ground.</li> <li>• Is voltage reading <b>B+</b>?</li> </ul>	Yes	Go to next step.
		No	Check for open circuit between ignition coil connector and ignition switch. Repair or replace wiring harness, then go to Step 23.
11	<b>INSPECT IGNITION COIL RESISTANCE</b> <ul style="list-style-type: none"> <li>• Check ignition coil resistance. (See 01-18-2 IGNITION COIL INSPECTION.)</li> <li>• Is coil resistance okay?</li> </ul>	Yes	Go to Step 23.
		No	Replace ignition coil, then go to Step 23.
12	<b>INSPECT MAF SIGNAL</b> <ul style="list-style-type: none"> <li>• Start engine.</li> <li>• Access MAF PID using WDS or equivalent.</li> <li>• Verify that MAF PID changes quickly according to race engine RPM.</li> <li>• Is MAF PID response okay?</li> </ul>	Yes	Go to next step.
		No	Replace MAF sensor, then go to Step 23.
13	<b>INSPECT EXCESSIVE AIR SUCTION IN INTAKE-AIR SYSTEM</b> <ul style="list-style-type: none"> <li>• Inspect for air leakage at following:                             <ul style="list-style-type: none"> <li>— Between MAF sensor and throttle body</li> <li>— Between throttle body and dynamic chamber</li> </ul> </li> <li>• Is there malfunction?</li> </ul>	Yes	Repair or replace suspected part, then go to Step 23.
		No	Go to next step.
14	<b>INSPECT FUEL LINE PRESSURE</b> <ul style="list-style-type: none"> <li>• Inspect fuel line pressure. (See 01-14-6 FUEL PRESSURE INSPECTION.)</li> <li>• Is fuel line pressure okay?</li> </ul>	Yes	Go to Step 18.
		No	If fuel line pressure is too high, go to next step. If fuel line pressure is too low, go to Step 16.
15	<b>VERIFY VACUUM LEADING TO PRESSURE REGULATOR</b> <ul style="list-style-type: none"> <li>• Disconnect vacuum hose from pressure regulator.</li> <li>• Start engine.</li> <li>• Is vacuum felt at opening end of vacuum hose?</li> </ul>	Yes	Check following: <ul style="list-style-type: none"> <li>• Fuel pump maximum pressure (See 01-14-15 FUEL PUMP UNIT INSPECTION.)</li> <li>• Fuel return hose for clogging                                     <ul style="list-style-type: none"> <li>— If all above are okay, replace pressure regulator.</li> </ul> </li> </ul> Then go to Step 23.
		No	Verify vacuum hoses are connected correctly. <ul style="list-style-type: none"> <li>• If okay, replace pressure regulator control solenoid valve.</li> <li>• If not, reconnect vacuum hose in proper position.</li> </ul> Then go to Step 23.
16	<b>INSPECT FUEL PUMP MAXIMUM PRESSURE</b> <ul style="list-style-type: none"> <li>• Inspect fuel pump maximum pressure. (See 01-14-15 FUEL PUMP UNIT INSPECTION.)</li> <li>• Is fuel pump maximum pressure <b>within 450—630 kPa {4.5—6.5 kgf/cm<sup>2</sup>, 64—92 psi}</b>?</li> </ul>	Yes	Go to next step.
		No	Inspect fuel pump circuit for open or poor connection. Repair or replace suspected circuit, then go to Step 23. <ul style="list-style-type: none"> <li>• If okay, replace fuel pump, then go to Step 23.</li> </ul>
17	<b>INSPECT FUEL LINE FROM FUEL PUMP TO FUEL DELIVERY PIPE</b> <ul style="list-style-type: none"> <li>• Visually inspect for fuel leakage in fuel line for any leakage.</li> <li>• Is any fuel leakage found?</li> </ul>	Yes	Replace suspected fuel line, then go to Step 23.
		No	Inspect fuel filters for following: <ul style="list-style-type: none"> <li>• Restriction or clogging at fuel filter (high-pressure).</li> <li>• Foreign material or stain inside fuel filter (low-pressure)</li> </ul> Perform following actions as result. <ul style="list-style-type: none"> <li>• If restriction or clogging is found at fuel filter (high-pressure), replace fuel filter (high-pressure).</li> <li>• If foreign material or stain is found inside fuel filter (low-pressure), clean fuel tank and fuel filter (low-pressure).</li> <li>• If all items above are okay, replace pressure regulator.</li> </ul> Then, go to Step 23.

01-02B

## ON-BOARD DIAGNOSTIC [ENGINE CONTROL SYSTEM (FS)]

STEP	INSPECTION	ACTION	
18	<b>INSPECT ENGINE COMPRESSION</b> <ul style="list-style-type: none"> <li>• Inspect engine compression. (See 01–10B–8 COMPRESSION INSPECTION [FS].)</li> <li>• Is it okay?</li> </ul>	Yes	Go to next step.
		No	Implement engine overhaul for repairs, then go to Step 23.
19	<b>INSPECT OPERATION OF PURGE CONTROL SOLENOID VALVE</b> <ul style="list-style-type: none"> <li>• Inspect purge solenoid valve. (See 01–16–12 PURGE SOLENOID VALVE INSPECTION.)</li> <li>• Is purge control solenoid valve operation okay?</li> </ul>	Yes	Go to next step.
		No	Replace purge control solenoid valve, then go to Step 23.
20	<b>INSPECT PCV VALVE OPERATION</b> <ul style="list-style-type: none"> <li>• Turn ignition key to OFF.</li> <li>• Remove PCV valve and check valve operation. (See 01–16–18 POSITIVE CRANKCASE VENTILATION (PCV) VALVE INSPECTION.)</li> <li>• Is PCV valve operation okay?</li> </ul>	Yes	Replace PCV valve, then go to Step 23.
		No	Go to next step.
21	<b>INSPECT OPERATION OF EGR VALVE</b> <ul style="list-style-type: none"> <li>• Remove EGR valve.</li> <li>• Visually check for stuck open condition.</li> <li>• Is EGR valve stuck open?</li> </ul>	Yes	Repair or replace EGR valve, then go to Step 23.
		No	Go to next step.
22	<b>INSPECT SEALING OF ENGINE COOLANT PASSAGE</b> <p><b>Warning</b></p> <ul style="list-style-type: none"> <li>• <b>Removing radiator cap when radiator is hot is dangerous. Scalding coolant and steam may shoot out and cause serious injury.</b></li> <li>• <b>When removing radiator cap, wrap thick cloth around and turn it slowly.</b></li> </ul> <ul style="list-style-type: none"> <li>• Remove radiator cap.</li> <li>• Implement procedure to bleed air from engine coolant, then run engine at idle.</li> <li>• Is there any small bubble which makes engine coolant white at filling opening?</li> </ul> <p><b>Note</b></p> <ul style="list-style-type: none"> <li>• Large bubbles are normal since they are remaining air coming out from engine coolant passage.</li> </ul>	Yes	Air gets in from poor sealing on head gasket or other areas between combustion chamber and engine coolant passage. Repair or replace faulty parts, then go to next step.
		No	Go to next step.
23	<b>VERIFY TROUBLESHOOTING OF MISFIRE DTC COMPLETED</b> <ul style="list-style-type: none"> <li>• Make sure to reconnect all disconnected connectors.</li> <li>• Turn ignition key to ON (Engine OFF).</li> <li>• Clear DTC from memory using WDS or equivalent.</li> <li>• Start engine and perform OBD-II DRIVE MODE 1. (See 01–02B–10 Mode 1 (PCM adaptive memory procedure drive mode).)</li> <li>• Is PENDING CODE of same DTC present?</li> </ul>	Yes	Replace PCM, then go to next step.
		No	Go to next step.
24	<b>VERIFY AFTER REPAIR PROCEDURE</b> <ul style="list-style-type: none"> <li>• Perform “After Repair Procedure”. (See 01–02B–9 AFTER REPAIR PROCEDURE [FS].)</li> <li>• Is there any DTC present?</li> </ul>	Yes	Go to applicable DTC inspection. (See 01–02B–15 DTC TABLE [FS].)
		No	Troubleshooting completed.

# ON-BOARD DIAGNOSTIC [ENGINE CONTROL SYSTEM (FS)]

DTC P0301, P0302, P0303, P0304 [FS]

A3U010201085W02

<p>DTC P0301 DTC P0302 DTC P0303 DTC P0304</p>	<p><b>Cylinder No.1 misfire detected</b> <b>Cylinder No.2 misfire detected</b> <b>Cylinder No.3 misfire detected</b> <b>Cylinder No.4 misfire detected</b></p>
<b>DETECTION CONDITION</b>	<ul style="list-style-type: none"> <li>PCM monitors CKP sensor input signal interval time. PCM calculates the change of the interval time for each cylinder. If the change of interval time exceeds the pre programmed criteria, PCM detects a misfire in the corresponding cylinder. While the engine is running, PCM counts the number of misfires that occurred at <b>200 crankshaft revolutions</b> and <b>1,000 crankshaft revolutions</b> and calculates misfire ratio for each crankshaft revolution. If the ratio exceeds the pre programmed criteria, PCM determines that a misfire, which can damage the catalytic converter or affect emission performance, has occurred.</li> </ul> <p><b>Diagnostic support note</b></p> <ul style="list-style-type: none"> <li>This is a continuous monitor (MISFIRE).</li> <li>MIL illuminates if PCM detects the misfire which affects emission performance in two consecutive drive cycles.</li> <li>PENDING CODE is available if PCM detects the misfire which affects emission performance during first drive cycle.</li> <li>MIL flashes if PCM detects the misfire which can damage the catalytic converter during first drive cycle. Therefore, PENDING CODE is not available while MIL flashes.</li> <li>FREEZE FRAME DATA is available.</li> <li>DTC is stored in PCM memory.</li> </ul>
<b>POSSIBLE CAUSE</b>	<ul style="list-style-type: none"> <li>Spark plug malfunction</li> <li>High-tension lead malfunction</li> <li>Fuel injector malfunction</li> <li>Air suction in intake-air system (between dynamic chamber and cylinder head)</li> <li>Inadequate engine compression due to engine internal malfunction</li> <li>Related connector or terminal malfunction</li> <li>Related wiring harness malfunction</li> </ul>

01-02B

## Diagnostic procedure

STEP	INSPECTION		ACTION
1	<p><b>VERIFY FREEZE FRAME DATA HAS BEEN RECORDED</b></p> <ul style="list-style-type: none"> <li>Has FREEZE FRAME DATA been recorded?</li> </ul>	Yes	Go to next step.
		No	Record FREEZE FRAME DATA on repair order, then go to next step.
2	<p><b>VERIFY RELATED REPAIR INFORMATION AVAILABILITY</b></p> <ul style="list-style-type: none"> <li>Check for related Service Bulletins availability.</li> <li>Is any related repair information available?</li> </ul>	Yes	Perform repair or diagnosis according to available repair information. <ul style="list-style-type: none"> <li>If vehicle is not repaired, go to next step.</li> </ul>
		No	Go to next step.
3	<p><b>VERIFY RELATED PENDING CODE OR STORED DTCs</b></p> <ul style="list-style-type: none"> <li>Turn ignition key to OFF then start engine.</li> <li>Verify related pending code or stored DTCs.</li> <li>Are other DTCs present?</li> </ul>	Yes	Go to appropriate DTC troubleshooting. (See 01-02B-15 DTC TABLE [FS].)
		No	Go to next step.
4	<p><b>VERIFY CURRENT INPUT SIGNAL STATUS (IGNITION KEY TO ON /IDLE)</b></p> <ul style="list-style-type: none"> <li>Access ECT, IAT, MAF, RPM, TP and VS PIDs using WDS or equivalent. (See 01-40B-7 PCM Inspection Using the SST (WDS or equivalent).)</li> <li>Is there any signal that is far out of specification when ignition switch is ON and engine runs at idle?</li> </ul>	Yes	Inspect suspected circuit and/or part according to inspection results. Then go to Step 12. (See 01-40B-7 PCM Inspection Using the SST (WDS or equivalent).)
		No	Go to next step.
5	<p><b>VERIFY CURRENT INPUT SIGNAL STATUS UNDER TROUBLE CONDITION</b></p> <ul style="list-style-type: none"> <li>Inspect same PIDs as in Step 4 while simulating FREEZE FRAME DATA condition.</li> <li>Is there any signal which causes drastic changes?</li> </ul>	Yes	Inspect suspected circuit and/or part according to inspection results. Then go to Step 13. (See 01-40B-7 PCM Inspection Using the SST (WDS or equivalent).)
		No	Go to next step.
6	<p><b>INSPECT SPARK PLUG CONDITION</b></p> <ul style="list-style-type: none"> <li>Turn ignition key to OFF.</li> <li>Remove spark plug from suspected cylinder.</li> <li>Check spark plug condition:                             <ul style="list-style-type: none"> <li>— Cracks</li> <li>— Excessive wear</li> <li>— Gap</li> <li>— Wet</li> </ul> </li> <li>Is any problem found on spark plug?</li> </ul>	Yes	<ul style="list-style-type: none"> <li>If spark plug is wet, fuel flooding is suspected. Go to Step 13.</li> <li>If spark plug has cracks, excessive wear or improper gap, replace faulty spark plug. Then go to Step 13.</li> </ul>
		No	Go to next step.

## ON-BOARD DIAGNOSTIC [ENGINE CONTROL SYSTEM (FS)]

STEP	INSPECTION	ACTION	
7	<b>VERIFY HIGH-TENSION LEAD CONDITION</b> <ul style="list-style-type: none"> <li>• Remove high-tension lead.</li> <li>• Check high-tension lead condition and resistance.                             <ul style="list-style-type: none"> <li>— Cracks</li> <li>— Spark shorts to cylinder head through high-tension lead insulator</li> </ul> </li> <li>• Is high-tension lead okay?</li> </ul>	Yes	Go to next step.
		No	Replace high-tension lead, then go to Step 13.
8	<b>INSPECT FOR AIR SUCTION AT INTAKE-AIR SYSTEM</b> <ul style="list-style-type: none"> <li>• Inspect for air leakage at following:                             <ul style="list-style-type: none"> <li>— Around connection of dynamic chamber and intake manifold</li> <li>— Around connection of intake manifold and cylinder head</li> </ul> </li> <li>• Is air leakage found?</li> </ul>	Yes	Repair or replace suspected part, then go to Step 13.
		No	Go to next step.
9	<b>INSPECT FUEL INJECTOR HARNESS</b> <ul style="list-style-type: none"> <li>• Remove intake-air system parts.</li> <li>• Disconnect fuel injector connector on suspected cylinder.</li> <li>• Connect TEST LIGHT (LED) to fuel injector connector terminals.</li> <li>• Check dim of light during cranking.</li> <li>• Does TEST LIGHT (LED) illuminate?</li> </ul>	Yes	Go to next step.
		No	Check for fuel injector harnesses. Repair or replace if necessary, then go to Step 13.
10	<b>INSPECT SEALING OF ENGINE COOLANT PASSAGE</b> <p><b>Warning</b></p> <ul style="list-style-type: none"> <li>• <b>Removing radiator cap when radiator is hot is dangerous, Scalding coolant and steam may shoot out and cause serious injury.</b></li> <li>• <b>When removing radiator cap, wrap thick cloth around and turn it slowly.</b></li> </ul> <ul style="list-style-type: none"> <li>• Remove radiator cap.</li> <li>• Implement procedure to bleed air from engine coolant, then run engine at idle.</li> <li>• Is there any small bubble which makes engine coolant white at filling opening?</li> </ul> <p><b>Note</b></p> <ul style="list-style-type: none"> <li>• Large bubbles are normal since they are remaining air coming out from engine coolant passage.</li> </ul>	Yes	Air gets in from poor sealing on head gasket or other areas between combustion chamber and engine coolant passage. Repair or replace faulty parts, then go to Step 13.
		No	Go to next step.
11	<b>INSPECT ENGINE COMPRESSION</b> <ul style="list-style-type: none"> <li>• Inspect engine compression. (See 01-10B-8 COMPRESSION INSPECTION [FS].)</li> <li>• Is engine compression okay?</li> </ul>	Yes	Go to next step.
		No	Overhaul the engine, then go to next step.
12	<b>INSPECT FUEL INJECTOR OPERATION</b> <ul style="list-style-type: none"> <li>• Remove fuel injector from suspected cylinder.</li> <li>• Swap injector with injector on other cylinder.</li> <li>• Start engine and run it at idle.</li> <li>• Does misfire DTC move to cylinder with suspected injector?</li> </ul>	Yes	Replace injector, then go to Step 13.
		No	Go to next step.

# ON-BOARD DIAGNOSTIC [ENGINE CONTROL SYSTEM (FS)]

01-02B

STEP	INSPECTION		ACTION
13	<b>VERIFY TROUBLESHOOTING OF MISFIRE DTC COMPLETED</b> <ul style="list-style-type: none"> <li>Make sure to reconnect all disconnected connectors.</li> <li>Start engine.</li> <li>Clear DTC from PCM memory using WDS or equivalent.</li> <li>Perform OBD-II DRIVE MODE 1. (See 01-02B-10 Mode 1 (PCM adaptive memory procedure drive mode).)</li> <li>Is same PENDING CODE or stored code of same DTC present?</li> </ul>	Yes	Replace PCM, then go to next step.
		No	Go to next step.
14	<b>VERIFY AFTER REPAIR PROCEDURE</b> <ul style="list-style-type: none"> <li>Perform "After Repair Procedure". (See 01-02B-9 AFTER REPAIR PROCEDURE [FS].)</li> <li>Is there any DTC present?</li> </ul>	Yes	Go to applicable DTC inspection. (See 01-02B-15 DTC TABLE [FS].)
		No	Troubleshooting completed.

## DTC P0325 [FS]

A3U010201085W03

DTC P0325	Knock sensor circuit malfunction
<b>DETECTION CONDITION</b>	<ul style="list-style-type: none"> <li>PCM monitors input signal from knock sensor when the following monitoring conditions are met. If PCM does not receive input signal from knock sensor for <b>5 seconds</b>, PCM determines that knock sensor circuit is malfunctioning.</li> </ul> <p><b>MONITORING CONDITIONS</b></p> <ul style="list-style-type: none"> <li>— Engine load is <b>above 50%</b></li> <li>— Engine coolant temperature is <b>above 60 °C {140 °F}</b>.</li> <li>— Engine speed is <b>within 1,500—5,000 rpm</b>.</li> </ul> <p><b>Diagnostic support note</b></p> <ul style="list-style-type: none"> <li>This is a continuous monitor (CCM).</li> <li>MIL illuminates if PCM detects the above malfunction condition during first drive cycle.</li> <li>PENDING CODE is not available.</li> <li>FREEZE FRAME DATA is available.</li> <li>DTC is stored in the PCM memory.</li> </ul>
<b>POSSIBLE CAUSE</b>	<ul style="list-style-type: none"> <li>Knock sensor malfunction</li> <li>Connector or terminal malfunction</li> <li>Open or short to ground circuit between knock sensor connector terminal A and PCM terminal 57</li> <li>Open or short to ground circuit between knock sensor connector terminal B and PCM terminal 59</li> <li>Short between two wires of knock sensor</li> </ul>

## ON-BOARD DIAGNOSTIC [ENGINE CONTROL SYSTEM (FS)]

### Diagnostic procedure

STEP	INSPECTION	ACTION	
1	<b>VERIFY FREEZE FRAME DATA HAS BEEN RECORDED</b> <ul style="list-style-type: none"> <li>• Has FREEZE FRAME DATA been recorded?</li> </ul>	Yes	Go to next step.
		No	Record FREEZE FRAME DATA on repair order, then go to next step.
2	<b>VERIFY RELATED REPAIR INFORMATION AVAILABILITY</b> <ul style="list-style-type: none"> <li>• Check for related Service Bulletins availability.</li> <li>• Is any related repair information available?</li> </ul>	Yes	Perform repair or diagnosis according to available repair information. <ul style="list-style-type: none"> <li>• If vehicle is not repaired, go to next step.</li> </ul>
		No	Go to next step.
3	<b>INSPECT PCM CONNECTOR TERMINAL</b> <ul style="list-style-type: none"> <li>• Turn ignition key to OFF.</li> <li>• Disconnect PCM connector.</li> <li>• Check for poor connection at terminals 57 and 66 (damaged, pulled-out pins, corrosion, etc.).</li> <li>• Is there any malfunction?</li> </ul>	Yes	Repair terminal, then go to Step 8.
		No	Go to next step.
4	<b>INSPECT KNOCK SENSOR CIRCUITS FOR OPEN CIRCUIT</b> <ul style="list-style-type: none"> <li>• Disconnect knock sensor connector.</li> <li>• Check continuity between the following circuits:                             <ul style="list-style-type: none"> <li>— Knock sensor female terminal A (harness-side) and PCM terminal 57 (harness-side)</li> <li>— Knock sensor female terminal B (harness-side) and PCM terminal 59 (harness-side)</li> </ul> </li> <li>• Is there continuity?</li> </ul>	Yes	Go to next step.
		No	Repair or replace suspected wiring harness, then go to Step 8.
5	<b>INSPECT KNOCK SENSOR CIRCUITS FOR SHORT TO GROUND</b> <ul style="list-style-type: none"> <li>• Check continuity between following circuits:                             <ul style="list-style-type: none"> <li>— Knock sensor female terminal A (harness-side) and body ground</li> <li>— Knock sensor female terminal B (harness-side) and body ground</li> </ul> </li> <li>• Is there continuity?</li> </ul>	Yes	Repair or replace suspected wiring harness, then go to Step 8.
		No	Go to next step.
6	<b>CHECK FOR SHORT CIRCUITS</b> <ul style="list-style-type: none"> <li>• Check continuity between knock sensor female terminals A and B (harness-side).</li> <li>• Is there continuity?</li> </ul>	Yes	Repair or replace suspected harness, then go to Step 8.
		No	Go to next step.
7	<b>CHECK KNOCK SENSOR RESISTANCE</b> <ul style="list-style-type: none"> <li>• Measure resistance between knock sensor terminals (part-side).</li> <li>• Is resistance <b>approx. 560 kilohms</b>?</li> </ul>	Yes	Go to next step.
		No	Replace knock sensor, then go to next step.
8	<b>VERIFY TROUBLESHOOTING OF DTC P0325 COMPLETED</b> <ul style="list-style-type: none"> <li>• Make sure to reconnect all disconnected connectors.</li> <li>• Turn ignition key to ON (Engine OFF).</li> <li>• Clear DTC from memory using WDS or equivalent.</li> <li>• Start engine.</li> <li>• Access ECT, RPM and LOAD PIDs using WDS or equivalent.</li> <li>• Run vehicle <b>more than 5 seconds</b> in the following conditions:                             <ul style="list-style-type: none"> <li>— ECT: <b>above 60 °C {140 °F}</b></li> <li>— RPM: <b>1,500—5,000 rpm</b></li> <li>— LOAD: <b>above 50%</b></li> </ul> </li> <li>• Is same DTC present?</li> </ul>	Yes	Replace or reprogram PCM. Then go to next step.
		No	Go to next step.
9	<b>VERIFY AFTER REPAIR PROCEDURE</b> <ul style="list-style-type: none"> <li>• Perform "After Repair Procedure" (See 01–02B–9 AFTER REPAIR PROCEDURE [FS].)</li> <li>• Is there any DTC present?</li> </ul>	Yes	Go to applicable DTC inspection. (See 01–02B–15 DTC TABLE [FS].)
		No	Troubleshooting completed.

# ON-BOARD DIAGNOSTIC [ENGINE CONTROL SYSTEM (FS)]

**DTC P0335 [FS]**

A3U010201085W04

01-02B

<b>DTC P0335</b>	<b>CKP sensor circuit malfunction</b>
<b>DETECTION CONDITION</b>	<ul style="list-style-type: none"> <li>If PCM does not receive input signal from CKP sensor for <b>4.2 seconds</b> while MAF is <b>2.2 g/s {0.29 lb/min}</b> or above, PCM determines that CKP sensor circuit has a malfunction.</li> </ul> <p><b>Diagnostic support note</b></p> <ul style="list-style-type: none"> <li>This is a continuous monitor (CCM).</li> <li>MIL illuminates if PCM detects the above malfunction conditions during first drive cycle. Therefore, PENDING CODE is not available.</li> <li>FREEZE FRAME DATA is available.</li> <li>DTC is stored in PCM memory.</li> </ul>
<b>POSSIBLE CAUSE</b>	<ul style="list-style-type: none"> <li>CKP sensor malfunction</li> <li>Connector or terminal malfunction</li> <li>CKP sensor is dirty.</li> <li>Short to ground between CKP sensor terminal A and PCM terminal 21</li> <li>Short to ground between CKP sensor terminal B and PCM terminal 22</li> <li>Open circuit between CKP sensor terminal A and PCM terminal 21</li> <li>Open circuit between CKP sensor terminal B and PCM terminal 22</li> <li>CKP sensor pulse wheel malfunction</li> </ul>

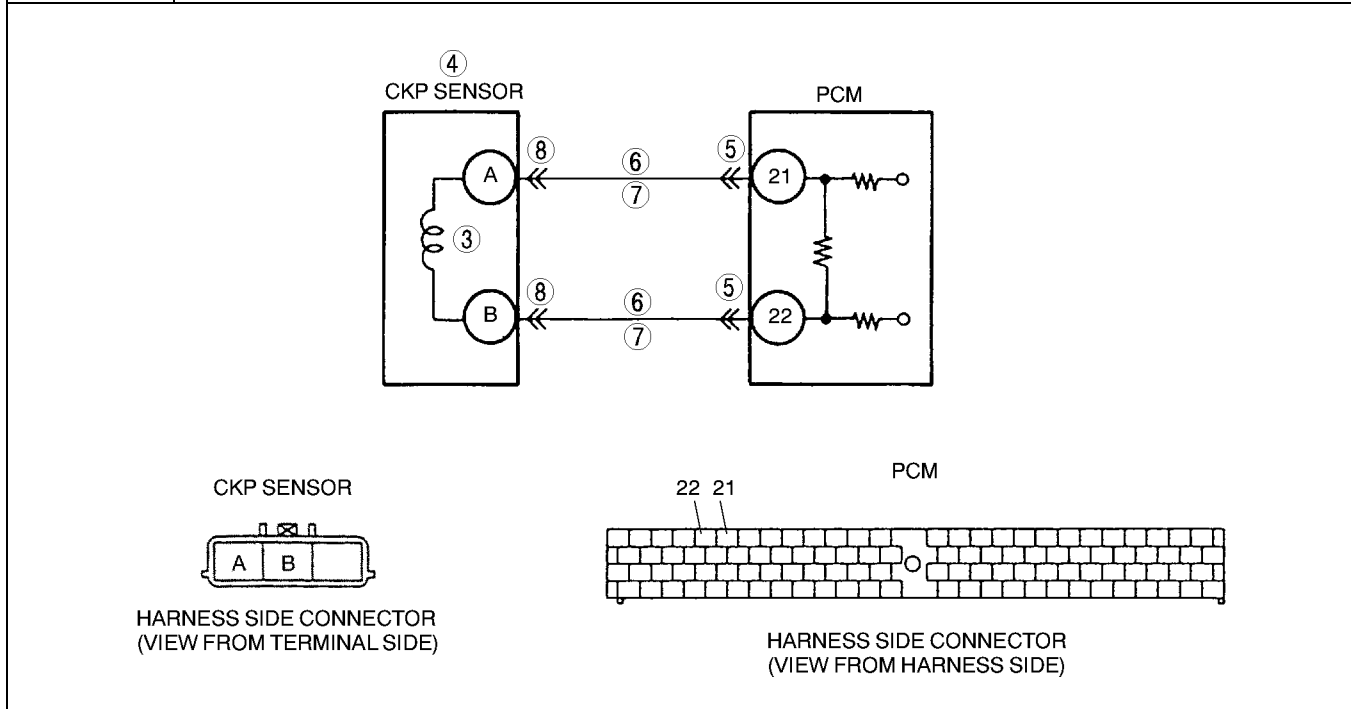

**Diagnostic procedure**

STEP	INSPECTION		ACTION
1	<b>VERIFY FREEZE FRAME DATA HAS BEEN RECORDED</b> <ul style="list-style-type: none"> <li>Has FREEZE FRAME DATA been recorded?</li> </ul>	Yes	Go to next step.
		No	Record FREEZE FRAME DATA on repair order, then go to next step.
2	<b>VERIFY RELATED REPAIR INFORMATION AVAILABILITY</b> <ul style="list-style-type: none"> <li>Check for related Service Bulletins availability.</li> <li>Is any related repair information available?</li> </ul>	Yes	Perform repair or diagnosis according to available repair information. <ul style="list-style-type: none"> <li>If vehicle is not repaired, go to next step.</li> </ul>
		No	Go to next step.
3	<b>VERIFY CKP SENSOR VOLTAGE</b> <ul style="list-style-type: none"> <li>Disconnect CKP sensor.</li> <li>Connect voltmeter between CKP sensor terminals A and B (part-side).</li> <li>Check voltage in AC range while cranking the engine.</li> <li>Is any voltage present?</li> </ul>	Yes	Go to Step 5.
		No	Go to next step.
4	<b>INSPECT CKP SENSOR RESISTANCE</b> <ul style="list-style-type: none"> <li>Inspect CKP sensor. (See 01-40B-32 CRANKSHAFT POSITION (CKP) SENSOR INSPECTION [FS].)</li> <li>Is CKP sensor okay?</li> </ul>	Yes	Check for poor connection (damaged/pulled-out terminals, corrosion, etc.), bent terminal of CKP sensor connector or plate. <ul style="list-style-type: none"> <li>Repair if necessary, then go to Step 9.</li> </ul>
		No	Replace CKP sensor, then go to Step 9.

## ON-BOARD DIAGNOSTIC [ENGINE CONTROL SYSTEM (FS)]

STEP	INSPECTION	ACTION	
5	<b>INSPECT PCM CONNECTOR FOR POOR CONNECTION</b> <ul style="list-style-type: none"> <li>• Turn ignition key to OFF.</li> <li>• Disconnect PCM connector.</li> <li>• Check for poor connection at terminals 21 and 22 (damaged,/pulled-out terminals, corrosion, etc.).</li> <li>• Is there malfunction?</li> </ul>	Yes	Repair terminal, then go to Step 9.
		No	Go to next step.
6	<b>INSPECT CKP CIRCUIT FOR OPEN CIRCUIT</b> <ul style="list-style-type: none"> <li>• Check for continuity between following circuits:                             <ul style="list-style-type: none"> <li>— CKP sensor terminal A and PCM terminal 21 (harness-side)</li> <li>— CKP sensor terminal B and PCM terminal 22 (harness-side)</li> </ul> </li> <li>• Is there continuity?</li> </ul>	Yes	Go to next step.
		No	Repair or replace suspected harness, then go to Step 9.
7	<b>INSPECT CKP CIRCUIT FOR SHORT TO GROUND</b> <ul style="list-style-type: none"> <li>• Check for continuity between following terminal and body ground:                             <ul style="list-style-type: none"> <li>— CKP sensor terminal A (harness-side)</li> <li>— CKP sensor terminal B (harness-side)</li> </ul> </li> <li>• Is there continuity?</li> </ul>	Yes	Repair or replace suspected harness, then go to Step 9.
		No	Go to next step.
8	<b>INSPECT CKP CIRCUITS FOR INTERMEDIATE SHORT</b> <ul style="list-style-type: none"> <li>• Check for continuity between CKP sensor terminals A and B.</li> <li>• Is there continuity?</li> </ul>	Yes	Repair or replace suspected harness, then go to next step.
		No	Go to next step.
9	<b>VERIFY TROUBLESHOOTING OF DTC P0335 COMPLETED</b> <ul style="list-style-type: none"> <li>• Make sure to reconnect all disconnected connectors.</li> <li>• Turn ignition key to ON (Engine OFF).</li> <li>• Clear DTC from PCM memory using WDS or equivalent.</li> <li>• Start engine.</li> <li>• Access MAF PID using WDS or equivalent.</li> </ul> <p><b>Note</b></p> <ul style="list-style-type: none"> <li>• MAF PID should indicate <b>above 2.2 g/s {0.29 lb./min}</b> during this test.</li> </ul> <ul style="list-style-type: none"> <li>• Is same DTC present?</li> </ul>	Yes	Replace PCM, then go to next step.
		No	Go to next step.
10	<b>VERIFY AFTER REPAIR PROCEDURE</b> <ul style="list-style-type: none"> <li>• Perform "After Repair Procedure". (See 01-02B-9 AFTER REPAIR PROCEDURE [FS].)</li> <li>• Is there any DTC present?</li> </ul>	Yes	Go to applicable DTC inspection. (See 01-02B-15 DTC TABLE [FS].)
		No	Troubleshooting completed.

### DTC P0340 [FS]

A3U010201085W05

DTC P0340	CMP sensor circuit malfunction
<b>DETECTION CONDITION</b>	<ul style="list-style-type: none"> <li>• PCM monitors input voltage from CMP sensor while MAF is <b>above 2.2 g/s {0.29 lb./min}</b>. If PCM does not receive pulse signal the proper pulse signal timing basis on the CKP sensor signal, determines that CMP circuit has malfunction.</li> </ul> <p><b>Diagnostic support note</b></p> <ul style="list-style-type: none"> <li>• This is a continuous monitor (CCM).</li> <li>• MIL illuminates if PCM detects the above malfunction conditions during first drive cycle. Therefore, PENDING CODE is not available.</li> <li>• FREEZE FRAME DATA is available.</li> <li>• DTC is stored in PCM memory.</li> </ul>



# ON-BOARD DIAGNOSTIC [ENGINE CONTROL SYSTEM (FS)]

01-02B

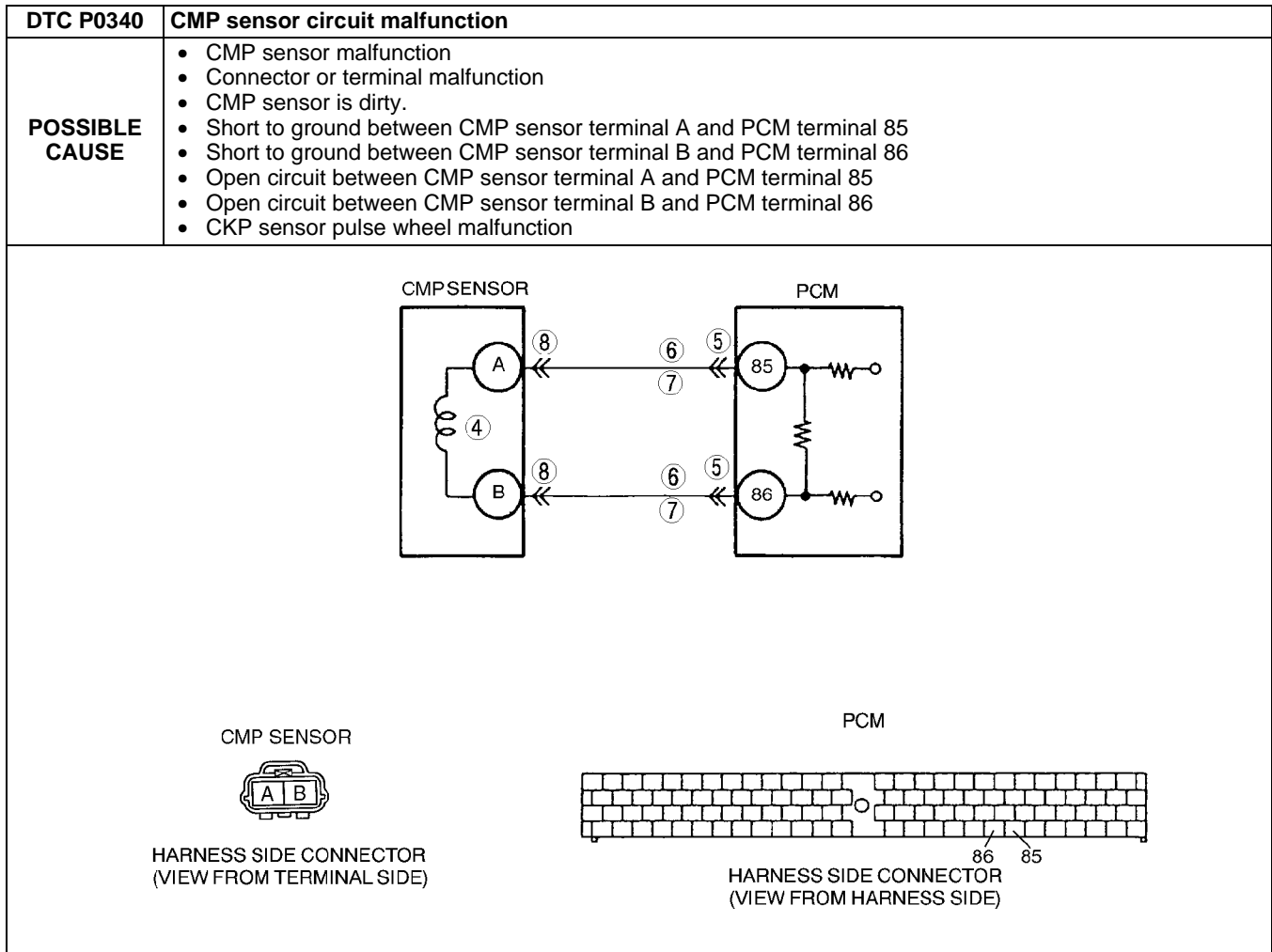

### Diagnostic procedure

STEP	INSPECTION		ACTION
1	<b>VERIFY FREEZE FRAME DATA HAS BEEN RECORDED</b> <ul style="list-style-type: none"> <li>Has FREEZE FRAME DATA been recorded?</li> </ul>	Yes	Go to next step.
		No	Record FREEZE FRAME DATA on repair order, then go to next step.
2	<b>VERIFY RELATED REPAIR INFORMATION AVAILABILITY</b> <ul style="list-style-type: none"> <li>Check for related Service Bulletins availability.</li> <li>Is any related repair information available?</li> </ul>	Yes	Perform repair or diagnosis according to available repair information. <ul style="list-style-type: none"> <li>If vehicle is not repaired, go to next step.</li> </ul>
		No	Go to next step.
3	<b>VERIFY CMP SENSOR VOLTAGE</b> <ul style="list-style-type: none"> <li>Disconnect CMP sensor.</li> <li>Connect voltmeter between CMP sensor terminals A and B (part-side).</li> <li>Check voltage in AC range while cranking the engine.</li> <li>Is any voltage reading?</li> </ul>	Yes	Go to Step 5.
		No	Go to next step.
4	<b>CHECK CMP SENSOR RESISTANCE</b> <ul style="list-style-type: none"> <li>Check resistance between CMP sensor terminals A and B (part-side).</li> <li>Is resistance <b>within 0.95—1.25 kilohms</b>?</li> </ul>	Yes	Check for poor connection (damaged/pulled-out terminals, corrosion, etc.), bent terminal of CMP sensor connector or plate. <ul style="list-style-type: none"> <li>Repair if necessary, then go to Step 10.</li> </ul>
		No	Replace CMP sensor, then go to Step 10.
5	<b>INSPECT PCM CONNECTOR FOR POOR CONNECTION</b> <ul style="list-style-type: none"> <li>Turn ignition key to OFF.</li> <li>Disconnect PCM connector.</li> <li>Check for poor connection at terminals 85 and 86 (damaged,/pulled-out terminals, corrosion, etc.).</li> <li>Is there any malfunction?</li> </ul>	Yes	Repair terminal, then go to Step 10.
		No	Go to next step.

## ON-BOARD DIAGNOSTIC [ENGINE CONTROL SYSTEM (FS)]

STEP	INSPECTION	ACTION	
6	<b>INSPECT CMP CIRCUIT FOR OPEN CIRCUIT</b> <ul style="list-style-type: none"> <li>• Check for continuity between following circuits:                             <ul style="list-style-type: none"> <li>— CMP sensor terminal A and PCM terminal 85 (harness-side)</li> <li>— CMP sensor terminal B and PCM terminal 86 (harness-side)</li> </ul> </li> <li>• Is there continuity?</li> </ul>	Yes	Go to next step.
		No	Repair or replace suspected harness, then go to Step 10.
7	<b>INSPECT CMP CIRCUIT FOR SHORT TO GROUND</b> <ul style="list-style-type: none"> <li>• Check for continuity between following terminal and body ground:                             <ul style="list-style-type: none"> <li>— CMP sensor terminal A (harness-side)</li> <li>— CMP sensor terminal B (harness-side)</li> </ul> </li> <li>• Is there continuity?</li> </ul>	Yes	Repair or replace suspected harness, then go to Step 10.
		No	Go to next step.
8	<b>INSPECT CMP CIRCUITS FOR INTERMEDIATE SHORT</b> <ul style="list-style-type: none"> <li>• Check for continuity between CMP sensor terminals A and B (harness-side).</li> <li>• Is there continuity?</li> </ul>	Yes	Repair or replace suspected harness, then go to next step.
		No	Go to next step.
9	<b>INSPECT CKP SENSOR</b> <ul style="list-style-type: none"> <li>• Check CKP sensor. (See 01-40B-32 CRANKSHAFT POSITION (CKP) SENSOR INSPECTION [FS].)</li> <li>• Is CKP sensor okay?</li> </ul>	Yes	Go to next step.
		No	Replace CKP sensor, then go to next step.
10	<b>VERIFY TROUBLESHOOTING OF DTC P0340 COMPLETED</b> <ul style="list-style-type: none"> <li>• Make sure to reconnect all disconnected connectors.</li> <li>• Turn ignition key to ON (Engine OFF).</li> <li>• Clear DTC from PCM memory using WDS or equivalent.</li> <li>• Start engine.</li> <li>• Access MAF PID using WDS or equivalent.</li> </ul> <p><b>Note</b></p> <ul style="list-style-type: none"> <li>• MAF PID should indicate <b>above 2.2 g/s {0.29 lb./min}</b> during this test.</li> </ul> <ul style="list-style-type: none"> <li>• Is same DTC present?</li> </ul>	Yes	Replace PCM, then go to next step.
		No	Go to next step.
11	<b>VERIFY AFTER REPAIR PROCEDURE</b> <ul style="list-style-type: none"> <li>• Perform "After Repair Procedure". (See 01-02B-9 AFTER REPAIR PROCEDURE [FS].)</li> <li>• Is there any DTC present?</li> </ul>	Yes	Go to applicable DTC inspection. (See 01-02B-15 DTC TABLE [FS].)
		No	Troubleshooting completed.

### DTC P0401 [FS]

A3U010201086W01

DTC P0401	EGR flow insufficient detected
<b>DETECTION CONDITION</b>	<ul style="list-style-type: none"> <li>• Difference in intake manifold pressures when EGR is operated and when it is stopped is too small.</li> </ul> <p><b>Diagnostic support note</b></p> <ul style="list-style-type: none"> <li>• This is an intermittent monitor (EGR).</li> <li>• MIL illuminates if PCM detects the above malfunction conditions in two consecutive drive cycles.</li> <li>• DIAGNOSTIC MONITORING TEST RESULTS and PENDING CODE is available if PCM detects the above malfunction condition during first drive cycle.</li> <li>• FREEZE FRAME DATA is available.</li> <li>• DTC is stored in PCM memory.</li> </ul>
<b>POSSIBLE CAUSE</b>	<ul style="list-style-type: none"> <li>• EGR valve malfunction</li> <li>• EGR boost sensor malfunction</li> <li>• EGR boost sensor solenoid valve malfunction</li> <li>• EGR gasket malfunction</li> <li>• PCM malfunction</li> </ul>

# ON-BOARD DIAGNOSTIC [ENGINE CONTROL SYSTEM (FS)]

## Diagnostic procedure

STEP	INSPECTION	ACTION	
1	<b>VERIFY FREEZE FRAME DATA HAS BEEN RECORDED</b> <ul style="list-style-type: none"> <li>Has FREEZE FRAME DATA been recorded?</li> </ul>	Yes	Go to next step.
		No	Record FREEZE FRAME DATA on repair order, then go to next step.
2	<b>VERIFY RELATED REPAIR INFORMATION AVAILABILITY</b> <ul style="list-style-type: none"> <li>Check for related Service Bulletins availability.</li> <li>Is any related repair information available?</li> </ul>	Yes	Perform repair or diagnosis according to available repair information. <ul style="list-style-type: none"> <li>If vehicle is not repaired, go to next step.</li> </ul>
		No	Go to next step.
3	<b>INSPECT FOR OTHER DTCS</b> <ul style="list-style-type: none"> <li>Turn ignition key to OFF then start engine.</li> <li>Have other DTCs been stored?</li> </ul>	Yes	Go to applicable DTC troubleshooting.
		No	Go to next step.
4	<b>INSPECT VACUUM HOSE CONDITION</b> <ul style="list-style-type: none"> <li>Inspect vacuum hoses for clogging, any damages, freeze, or vacuum leakage.</li> <li>Is there malfunction?</li> </ul>	Yes	Replace vacuum hoses, then go to Step 9.
		No	Go to next step.
5	<b>INSPECT EGR VALVE MALFUNCTION</b> <ul style="list-style-type: none"> <li>Inspect EGR valve. (See 01-16-15 EGR VALVE INSPECTION.)</li> <li>Is EGR valve okay?</li> </ul>	Yes	Go to next step.
		No	Replace EGR valve, then go to Step 9.
6	<b>INSPECT EGR BOOST SENSOR MALFUNCTION</b> <ul style="list-style-type: none"> <li>Inspect EGR boost sensor. (See 01-40B-39 EGR BOOST SENSOR INSPECTION [FS].)</li> <li>Is EGR boost sensor okay?</li> </ul>	Yes	Go to next step.
		No	Replace EGR boost sensor, then go to Step 9.
7	<b>INSPECT EGR BOOST SENSOR SOLENOID VALVE</b> <ul style="list-style-type: none"> <li>Inspect EGR boost sensor solenoid valve. (See 01-16-17 EGR BOOST SENSOR SOLENOID VALVE INSPECTION.)</li> <li>Is EGR boost sensor solenoid valve okay?</li> </ul>	Yes	Go to next step.
		No	Replace EGR boost sensor solenoid valve, then go to Step 9.
8	<b>INSPECT EGR VALVE PASSAGE</b> <ul style="list-style-type: none"> <li>Remove EGR valve.</li> <li>Is gasket installation normal?</li> </ul>	Yes	Go to next step.
		No	Install gasket correctly, then go to next step.
9	<b>MONITOR EGR SYSTEM BY DRIVE MODE</b> <ul style="list-style-type: none"> <li>Make sure to reconnect all disconnected connectors.</li> <li>Run OBD-II Drive Mode 1 and 2. (See 01-02B-10 OBD-II DRIVE MODE [FS].)</li> <li>Check EGR System Monitor completion status using On-Board Readiness Test function.</li> <li>Has EGR system been monitored?</li> </ul>	Yes	Go to next step.
		No	Retry this step.
10	<b>VERIFY TROUBLESHOOTING OF DTC P0401 COMPLETED</b> <ul style="list-style-type: none"> <li>Access DIAGNOSTIC MONITORING TEST RESULTS.</li> <li>Verify TEST ID 10:41:00 value.</li> <li>Is value within specification?</li> </ul>	Yes	Go to next step.
		No	Replace PCM, then go to next step.
11	<b>VERIFY AFTER REPAIR PROCEDURE</b> <ul style="list-style-type: none"> <li>Perform "After Repair Procedure". (See 01-02B-9 AFTER REPAIR PROCEDURE [FS].)</li> <li>Is there any DTC present?</li> </ul>	Yes	Go to applicable DTC inspection. (See 01-02B-15 DTC TABLE [FS].)
		No	Troubleshooting completed.

01-02B

## DTC P0402 [FS]

A3U010201086W02

DTC P0402	EGR flow excessive detected
<b>DETECTION CONDITION</b>	<ul style="list-style-type: none"> <li>Difference in intake manifold pressures when EGR is operated and when it is stopped is too large.</li> </ul> <p><b>Diagnostic support note</b></p> <ul style="list-style-type: none"> <li>This is an intermittent monitor (EGR).</li> <li>MIL illuminates if PCM detects the above malfunction conditions in two consecutive drive cycles.</li> <li>PENDING CODE is available if PCM detects the above malfunction condition during first drive cycle.</li> <li>FREEZE FRAME DATA is available.</li> <li>DTC is stored in PCM memory.</li> </ul>

01-02B-83

## ON-BOARD DIAGNOSTIC [ENGINE CONTROL SYSTEM (FS)]

<b>DTC P0402</b>	<b>EGR flow excessive detected</b>
<b>POSSIBLE CAUSE</b>	<ul style="list-style-type: none"> <li>• EGR valve gasket is not installed.</li> <li>• EGR valve gasket has been damaged.</li> <li>• PCM malfunction</li> </ul>

### Diagnostic procedure

STEP	INSPECTION		ACTION
1	<b>VERIFY FREEZE FRAME DATA HAS BEEN RECORDED</b> <ul style="list-style-type: none"> <li>• Has FREEZE FRAME DATA been recorded?</li> </ul>	Yes	Go to next step.
		No	Record FREEZE FRAME DATA on repair order, then go to next step.
2	<b>VERIFY RELATED REPAIR INFORMATION AVAILABILITY</b> <ul style="list-style-type: none"> <li>• Check for related Service Bulletins availability.</li> <li>• Is any related repair information available?</li> </ul>	Yes	Perform repair or diagnosis according to available repair information. <ul style="list-style-type: none"> <li>• If vehicle is not repaired, go to next step.</li> </ul>
		No	Go to next step.
3	<b>INSPECT FOR OTHER DTCs</b> <ul style="list-style-type: none"> <li>• Turn ignition key to OFF then start engine.</li> <li>• Have other DTCs been stored?</li> </ul>	Yes	Go to applicable DTC troubleshooting.
		No	Go to next step.
4	<b>INSPECT EGR VALVE GASKET</b> <ul style="list-style-type: none"> <li>• Turn ignition key to OFF.</li> <li>• Remove EGR valve.</li> <li>• Is EGR valve gasket installed?</li> </ul>	Yes	Go to next step.
		No	Install EGR valve gasket, then go to Step 6.
5	<b>INSPECT EGR VALVE GASKET MALFUNCTION</b> <ul style="list-style-type: none"> <li>• Does EGR valve gasket have any crack and/or damage?</li> </ul>	Yes	Replace EGR valve gasket, then go to Step 6.
		No	Go to next step.
6	<b>MONITOR EGR SYSTEM BY DRIVE MODE</b> <ul style="list-style-type: none"> <li>• Make sure to reconnect all disconnected connectors.</li> <li>• Run OBD-II Drive Mode 1 and 2. (See 01-02B-10 OBD-II DRIVE MODE [FS].)</li> <li>• Check EGR System Monitor completion status using On-Board Readiness Test function.</li> <li>• Has EGR system been monitored?</li> </ul>	Yes	Go to next step.
		No	Retry this step.
7	<b>VERIFY TROUBLESHOOTING OF DTC P0402 COMPLETED</b> <ul style="list-style-type: none"> <li>• Access DIAGNOSTIC MONITORING TEST RESULTS.</li> <li>• Verify TEST ID 10:41:00 value.</li> <li>• Is value within specification?</li> </ul>	Yes	Go to next step.
		No	Replace PCM, then go to next step.
8	<b>VERIFY AFTER REPAIR PROCEDURE</b> <ul style="list-style-type: none"> <li>• Perform "After Repair Procedure". (See 01-02B-9 AFTER REPAIR PROCEDURE [FS].)</li> <li>• Is there any DTC present?</li> </ul>	Yes	Go to applicable DTC inspection. (See 01-02B-15 DTC TABLE [FS].)
		No	Troubleshooting completed.

### DTC P0421 [FS]

A3U010201086W03

<b>DTC P0421</b>	<b>Warm-up catalyst system efficiency below threshold</b>
<b>DETECTION CONDITION</b>	<ul style="list-style-type: none"> <li>• PCM compares the number of HO2S (front) and HO2S (rear) inversions for a predetermined time. PCM monitors the number of inversions the rear side performs while the front side inverts for a specified number of times when the following monitoring conditions are met. PCM detects the inversion ratio. If inversion ratio is below threshold, PCM determines that catalyst system has deteriorated.</li> </ul> <p><b>MONITORING CONDITIONS</b></p> <ul style="list-style-type: none"> <li>— Engine speed is <b>1,500—3,000 rpm</b>.</li> <li>— Calculated load is <b>15—48%<sup>(*1)</sup></b>.</li> <li>— Vehicle speed is <b>28—120 km/h {17.3—74.5 mph}</b>.</li> </ul> <p>*1: Maximum calculated load value varies depending on engine speed.</p> <p><b>Diagnostic support note</b></p> <ul style="list-style-type: none"> <li>• This is an intermittent monitor. (CATALYST)</li> <li>• MIL illuminates if PCM detects the above malfunction conditions in two consecutive drive cycles.</li> <li>• DIAGNOSTIC MONITORING TEST RESULTS is available.</li> <li>• PENDING CODE is stored if PCM detects the above malfunction condition during first drive cycle.</li> <li>• FREEZE FRAME DATA is available.</li> <li>• DTC is stored in PCM memory.</li> </ul>

## ON-BOARD DIAGNOSTIC [ENGINE CONTROL SYSTEM (FS)]

<b>DTC P0421</b>	<b>Warm-up catalyst system efficiency below threshold</b>
<b>POSSIBLE CAUSE</b>	<ul style="list-style-type: none"> <li>• WU-TWC deterioration or malfunction</li> <li>• Exhaust gas leakage</li> <li>• Looseness of HO2S (front)</li> <li>• Looseness of HO2S (rear)</li> <li>• HO2S (front) malfunction</li> </ul>

### Diagnostic procedure

STEP	INSPECTION		ACTION
1	<b>VERIFY FREEZE FRAME DATA HAS BEEN RECORDED</b> • Has FREEZE FRAME DATA been recorded?	Yes	Go to next step.
		No	Record FREEZE FRAME DATA on repair order, then go to next step.
2	<b>VERIFY RELATED REPAIR INFORMATION AVAILABILITY</b> • Check for related Service Bulletins availability. • Is any related repair information available?	Yes	Perform repair or diagnosis according to available repair information. • If vehicle is not repaired, go to next step.
		No	Go to next step.
3	<b>VERIFY RELATED PENDING CODE OR STORED DTCS</b> • Turn ignition key to OFF then start engine. • Verify related pending code or stored DTCS. • Are other DTCS present?	Yes	Go to appropriate DTC troubleshooting.
		No	Go to next step.
4	<b>INSPECT EXHAUST SYSTEM GAS LEAKAGE</b> • Visually inspect exhaust gas leakage in exhaust system. • Is there any gas leakage?	Yes	Repair or replace faulty exhaust parts, then go to Step 7.
		No	Go to next step.
5	<b>INSPECT INSTALLATION OF FRONT AND REAR OXYGEN SENSORS</b> • Inspect for looseness of front and rear oxygen sensors. • Is it okay?	Yes	Go to next step.
		No	Retighten sensor, then go to Step 7.
6	<b>INSPECT WU-TWC</b> • Clear DTC using WDS or equivalent. • Inspect WU-TWC. (See 01-16-19 WARM UP THREE-WAY CATALYTIC CONVERTER (WU-TWC) INSPECTION.) • Is WU-TWC okay?	Yes	Replace suspected oxygen sensor, then go to next step.
		No	Replace WU-TWC, then go to next step.
7	<b>VERIFY TROUBLESHOOTING OF DTC P0421 COMPLETED</b> • Make sure to reconnect all disconnected connectors. • Turn ignition key to ON (Engine OFF). • Clear DTC from memory using WDS or equivalent. • Start engine and perform OBD-II DRIVE MODE except for MODE 4. (See 01-02B-10 OBD-II DRIVE MODE [FS].) • Is PENDING CODE of same DTC present?	Yes	Replace PCM, then go to next step.
		No	Go to next step.
8	<b>VERIFY AFTER REPAIR PROCEDURE</b> • Perform "After Repair Procedure". (See 01-02B-9 AFTER REPAIR PROCEDURE [FS].) • Is there any DTC present?	Yes	Go to applicable DTC inspection. (See 01-02B-15 DTC TABLE [FS].)
		No	Troubleshooting completed.

01-02B

# ON-BOARD DIAGNOSTIC [ENGINE CONTROL SYSTEM (FS)]

DTC P0442 [FS]

A3U010201086W04

DTC P0442	Evaporative emission control system leak detected (small leak)
<b>DETECTION CONDITION</b>	<ul style="list-style-type: none"> <li>• PCM measures the fuel tank pressure (ftp2), which is the vacuum when a specified period has passed after EVAP system is sealed. PCM determines the pressure difference between ftp1 and ftp2. If pressure difference exceeds the threshold, PCM determines that the EVAP system has a small leak. This monitor can activate when the PCM determines that the CONSTANTLY LEAK DETECTED test results are passed.</li> </ul> <p><b>THRESHOLD VALUE</b></p> <ul style="list-style-type: none"> <li>— Fuel tank pressure (ftp2—ftp1): <b>1.17—3.91 kPa {8.78—29.30 mmHg, 0.34—1.15 inHg}</b> <ul style="list-style-type: none"> <li>• Threshold value varies depends on ECT at engine start BARO.</li> </ul> </li> </ul> <p><b>MONITORING CONDITIONS</b></p> <ul style="list-style-type: none"> <li>— PCM monitors EVAP system when driving under following conditions:           <ul style="list-style-type: none"> <li>• Remaining fuel: <b>35—85%</b></li> <li>• ECT at engine start: <b>−10.0 °C—35 °C {14.0—95.0 °F}</b></li> <li>• Atmospheric pressure: <b>above 69.7 kPa {523 mmHg, 20.5 inHg}</b></li> <li>• Vehicle speed: <b>39.5—120.3 km/h {24.5—74.7 mph}</b></li> <li>• Engine speed: <b>1,000—4,000 rpm</b></li> <li>• Calculated load: <b>9—65%</b></li> <li>• Throttle opening angle: <b>3.1—12.5%</b></li> <li>• IAT during monitor: <b>−10—60 °C {14—140 °F}</b></li> </ul> </li> </ul> <p><b>Diagnostic support note</b></p> <ul style="list-style-type: none"> <li>• This is an intermittent monitor (Evaporative leak monitor).</li> <li>• MIL illuminates if PCM detects the above malfunction condition in two consecutive drive cycles.</li> <li>• DIAGNOSTIC MONITORING TEST RESULTS and PENDING CODE are stored if PCM detects the above malfunction condition during first drive cycle.</li> <li>• FREEZE FRAME DATA is available.</li> <li>• DTC is stored in PCM memory.</li> </ul>
<b>POSSIBLE CAUSE</b>	<ul style="list-style-type: none"> <li>• Purge solenoid valve malfunction</li> <li>• Canister drain cut valve (CDCV) malfunction</li> <li>• Pressure control valve malfunction</li> <li>• Loose or defective fuel filler cap</li> <li>• Charcoal canister malfunction</li> <li>• Catch tank malfunction</li> <li>• Rollover valve malfunction</li> <li>• Cracked fuel tank</li> <li>• Fuel tank component parts poorly installed</li> <li>• EVAP hose damaged or loose</li> </ul>

## Diagnostic procedure

STEP	INSPECTION		ACTION
1	<b>VERIFY FREEZE FRAME DATA HAS BEEN RECORDED</b> <ul style="list-style-type: none"> <li>• Has FREEZE FRAME DATA been recorded?</li> </ul>	Yes	Go to next step.
		No	Record FREEZE FRAME DATA on repair order, then go to next step.
2	<b>VERIFY RELATED REPAIR INFORMATION AVAILABILITY</b> <ul style="list-style-type: none"> <li>• Check for related Service Bulletins availability.</li> <li>• Is any related repair information available?</li> </ul>	Yes	Perform repair or diagnosis according to available repair information. <ul style="list-style-type: none"> <li>• If vehicle is not repaired, go to next step.</li> </ul>
		No	Go to next step.
3	<b>VERIFY RELATED PENDING CODE OR STORED DTCS</b> <ul style="list-style-type: none"> <li>• Turn ignition key to OFF then ON (Engine OFF).</li> <li>• Verify related pending code or stored DTCs.</li> <li>• Are DTCs P0443 and/or P1449 present?</li> </ul>	Yes	Go to appropriate DTC inspection.
		No	Go to next step.
4	<b>INSPECT FUEL-FILLER CAP</b> <ul style="list-style-type: none"> <li>• Verify fuel-filler cap is not either loose or damaged.</li> <li>• Is it okay?</li> </ul> <p><b>Note</b></p> <ul style="list-style-type: none"> <li>• When fuel-filler caps other than OEM caps are attached, it is considered malfunction.</li> </ul>	Yes	Go to next step.
		No	Retighten fuel-filler cap or replace it if it is damaged. Then go to Step 15.

## ON-BOARD DIAGNOSTIC [ENGINE CONTROL SYSTEM (FS)]

STEP	INSPECTION	ACTION	
5	<b>INSPECT WHOLE EVAP CONTROL SYSTEM</b> <ul style="list-style-type: none"> <li>Implement "01-03B ENGINE CONTROL SYSTEM OPERATION INSPECTION [FS], Evaporative System Leak Inspection Using Vacuum Pump, Whole system inspection". (See 01-03B-55 Whole system inspection.)</li> <li>Does voltage change under to specified readings and hold for <b>minimum of 2 minutes</b>?</li> </ul>	Yes	No leaks were detected in EVAP control system at this time. Go to Step 15.
		No	If evaporative emission tester is available, go to Step 14. If not, go to next step.
6	<b>INSPECT LEAKAGE OF FROM CHARCOAL CANISTER TO FUEL TANK</b> <ul style="list-style-type: none"> <li>Implement "01-03B ENGINE CONTROL SYSTEM OPERATION INSPECTION [FS], Evaporative System Leak Inspection Using Vacuum Pump, Inspection from charcoal canister to fuel tank". (See 01-03B-55 Inspection from charcoal canister to fuel tank.)</li> <li>Does voltage change under to specified readings and hold for a <b>minimum of 2 minutes</b>?</li> </ul>	Yes	Go to Step 9.
		No	Go to next step.
7	<b>INSPECT ATTACHED ACCESSORIES ON FUEL TANK</b> <ul style="list-style-type: none"> <li>Remove fuel tank and visually inspect for damage, insufficient sealing or poorly attached accessories on fuel tank, such as fuel gauge.</li> <li>Is it okay?</li> </ul>	Yes	Go to next step.
		No	Repair or replace fuel tank or sealing, then go to Step 15.
8	<b>INSPECT ROLLOVER VALVE</b> <ul style="list-style-type: none"> <li>Remove rollover valve and inspect for damage.</li> <li>Is it okay?</li> </ul>	Yes	Inspect for detached, incorrectly installed or cracked hoses on fuel tank and from charcoal canister to fuel tank. Repair or replace as necessary. Then go to step 15.
		No	Replace rollover valve, then go to Step 15.
9	<b>INSPECT LEAKAGE BETWEEN CHARCOAL CANISTER AND PURGE SOLENOID VALVE</b> <ul style="list-style-type: none"> <li>Implement "01-03B ENGINE CONTROL SYSTEM OPERATION INSPECTION [FS], Evaporative System Leak Inspection Using Vacuum Pump, Inspection from charcoal canister to purge solenoid valve". (See 01-03B-55 Inspection from charcoal canister to purge solenoid valve.)</li> <li>Does voltage change under to specified readings and hold for a <b>minimum of 2 minutes</b>?</li> </ul>	Yes	Go to Step 15.
		No	Go to next step.
10	<b>INSPECT CATCH TANK</b> <ul style="list-style-type: none"> <li>Remove catch tank and inspect for plugging, damages and pinhole using vacuum pump.</li> <li>Is it okay?</li> </ul>	Yes	Go to next step.
		No	Replace catch tank, then go to Step 15.
11	<b>INSPECT PURGE SOLENOID VALVE</b> <ul style="list-style-type: none"> <li>Remove purge solenoid valve and inspect for damage and air leakage.</li> <li>Is it okay?</li> </ul>	Yes	Go to next step.
		No	Replace purge solenoid valve, then go to Step 15.
12	<b>INSPECT CHARCOAL CANISTER</b> <ul style="list-style-type: none"> <li>Remove charcoal canister and inspect for damage and pinhole.</li> <li>Is it okay?</li> </ul>	Yes	Go to next step.
		No	Replace charcoal canister, then go to Step 15.
13	<b>INSPECT CDCV</b> <ul style="list-style-type: none"> <li>Remove CDCV and inspect for damage and air leakage.</li> <li>Is it okay?</li> </ul>	Yes	Inspect and repair or replace detached, incorrectly installed or cracked hoses from charcoal canister to CDCV. Then go to Step 15.
		No	Replace CDCV, then go to Step 15.
14	<b>INSPECT LEAKAGE OF EVAPORATIVE CONTROL SYSTEM</b> <ul style="list-style-type: none"> <li>Inspect evaporative control system for leakage using evaporative emission tester. (See 01-16-13 FUEL-FILLER CAP INSPECTION.)</li> <li>Is any leakage found?</li> </ul>	Yes	Repair or replace faulty area, then go to next step.
		No	Go to next step.

01-02B

## ON-BOARD DIAGNOSTIC [ENGINE CONTROL SYSTEM (FS)]

STEP	INSPECTION	ACTION	
15	<b>VERIFY MONITORING CONDITION FOR EVAPORATIVE SYSTEM TEST</b> <ul style="list-style-type: none"> <li>• Turn ignition key to ON (Engine OFF).</li> <li>• Verify that following conditions are met.                             <ul style="list-style-type: none"> <li>— BARO: <b>69.7 kPa {523 mmHg, 20.5 inHg} or higher</b></li> <li>— ECT: <b>-10.0—20.0 °C {14.0—68.0 °F} [at atmospheric pressure 69.7 kPa {523 mmHg, 20.5 inHg}]</b></li> <li>— IAT: <b>-10—60 °C {14—140 °F}</b></li> <li>— Fuel tank level: <b>35—85%</b></li> </ul> </li> <li>• Is there any PID that is out of specification?</li> </ul>	Yes	Go to next step.
		No	Go to Step 18.
16	<b>VERIFY EVAP SYSTEM REPAIRED</b> <ul style="list-style-type: none"> <li>• Carry out evaporative system test even if it is not test condition. (See 01-03B-54 Evaporative System Leak Inspection Using Leak Tester.)</li> <li>• Is system test result of small leak okay?</li> </ul>	Yes	EVAP system repaired. Go to Step 22.
		No	Go to next step.
17	<b>VERIFY MONITORING CONDITION FOR EVAPORATIVE SYSTEM TEST OR DRIVE MODE 4</b> <ul style="list-style-type: none"> <li>• Turn ignition key to ON (Engine OFF).</li> <li>• Verify that following conditions are met.                             <ul style="list-style-type: none"> <li>— BARO: <b>69.7 kPa {523 mmHg, 20.5 inHg} or higher</b></li> <li>— ECT: <b>-10.0—20.0 °C {14.0—68.0 °F} [at atmospheric pressure 69.7 kPa {523 mmHg, 20.5 inHg}]</b></li> <li>— IAT: <b>-10—60 °C {14—140 °F}</b></li> <li>— Fuel tank level: <b>35—85%</b></li> </ul> </li> <li>• Is there any PID that is out of specification?</li> </ul>	Yes	Take corrective action (e.g. cool down engine), then repeat this step.  <b>Note</b> <ul style="list-style-type: none"> <li>• Readings need to be in the indicated ranges to perform Drive Mode.</li> </ul>
		No	Then go to next step.
18	<b>DECIDE ON AFTER REPAIR PROCEDURE ACCORDING TO REPAIR SHOP CONDITION</b> <ul style="list-style-type: none"> <li>• Clear DTC from memory using WDS or equivalent.</li> <li>• Is repair shop possible to perform Drive Mode 4?</li> </ul>	Yes	Go to Step 20.
		No	Go to next step.
19	<b>VERIFY EVAP SYSTEM REPAIRED BY EVAPORATIVE SYSTEM TEST</b> <ul style="list-style-type: none"> <li>• Carry out evaporative system test. (See 01-03B-54 Evaporative System Leak Inspection Using Leak Tester.)</li> <li>• Is system test result okay?</li> </ul>	Yes	EVAP system repaired. Go to Step 22.
		No	Replace PCM, then go to Step 22.
20	<b>MONITOR EVAP SYSTEM BY DRIVE MODE 4</b> <ul style="list-style-type: none"> <li>• Run Drive Mode 4. (See 01-02B-12 Mode 4 (EVAP system repair verification drive mode).)</li> <li>• Stop vehicle and access ON BOARD SYSTEM READINESS TESTS to inspect Drive Mode completion status.</li> <li>• Has EVAPORATIVE PURGE SYSTEM been monitored?</li> </ul>	Yes	Go to next step.
		No	Go back to Step 17.
21	<b>VERIFY EVAP SYSTEM REPAIRED</b> <ul style="list-style-type: none"> <li>• Access DIAGNOSTIC MONITORING TEST RESULTS.</li> <li>• Is it below MAX value?</li> </ul>	Yes	Go to next step.
		No	Replace PCM, then go next step.
22	<b>VERIFY AFTER REPAIR PROCEDURE</b> <ul style="list-style-type: none"> <li>• Perform "After Repair Procedure". (See 01-02B-9 AFTER REPAIR PROCEDURE [FS].)</li> <li>• Is there any DTC present?</li> </ul>	Yes	Go to applicable DTC inspection. (See 01-02B-15 DTC TABLE [FS].)
		No	Troubleshooting completed.



# ON-BOARD DIAGNOSTIC [ENGINE CONTROL SYSTEM (FS)]

DTC P0443 [FS]

A3U010201086W05

01-02B

<b>DTC P0443</b>	<b>Evaporative emission solenoid system purge control valve circuit malfunction</b>
<b>DETECTION CONDITION</b>	<ul style="list-style-type: none"> <li>PCM monitors input voltages from purge solenoid valve. If voltage at PCM terminal 67 remains low or high, PCM determines that purge solenoid valve circuit has malfunction.</li> </ul> <p><b>Diagnostic support note</b></p> <ul style="list-style-type: none"> <li>This is a diagnostic support DTC (monitored one per key cycle).</li> <li>MIL does not illuminate.</li> <li>FREEZE FRAME DATA is not available.</li> <li>DTC is not stored in PCM memory.</li> </ul>
<b>POSSIBLE CAUSE</b>	<ul style="list-style-type: none"> <li>Purge solenoid valve malfunction</li> <li>Connector or terminal malfunction</li> <li>Short to ground in wiring between purge solenoid valve terminal B and PCM terminal 67</li> <li>Open circuit in wiring between main relay terminal D and purge solenoid valve terminal A</li> <li>Open circuit in wiring between purge solenoid valve terminal B and PCM terminal 67</li> <li>Short to power circuit between purge solenoid valve terminal B and PCM terminal 67</li> <li>PCM malfunction</li> </ul>

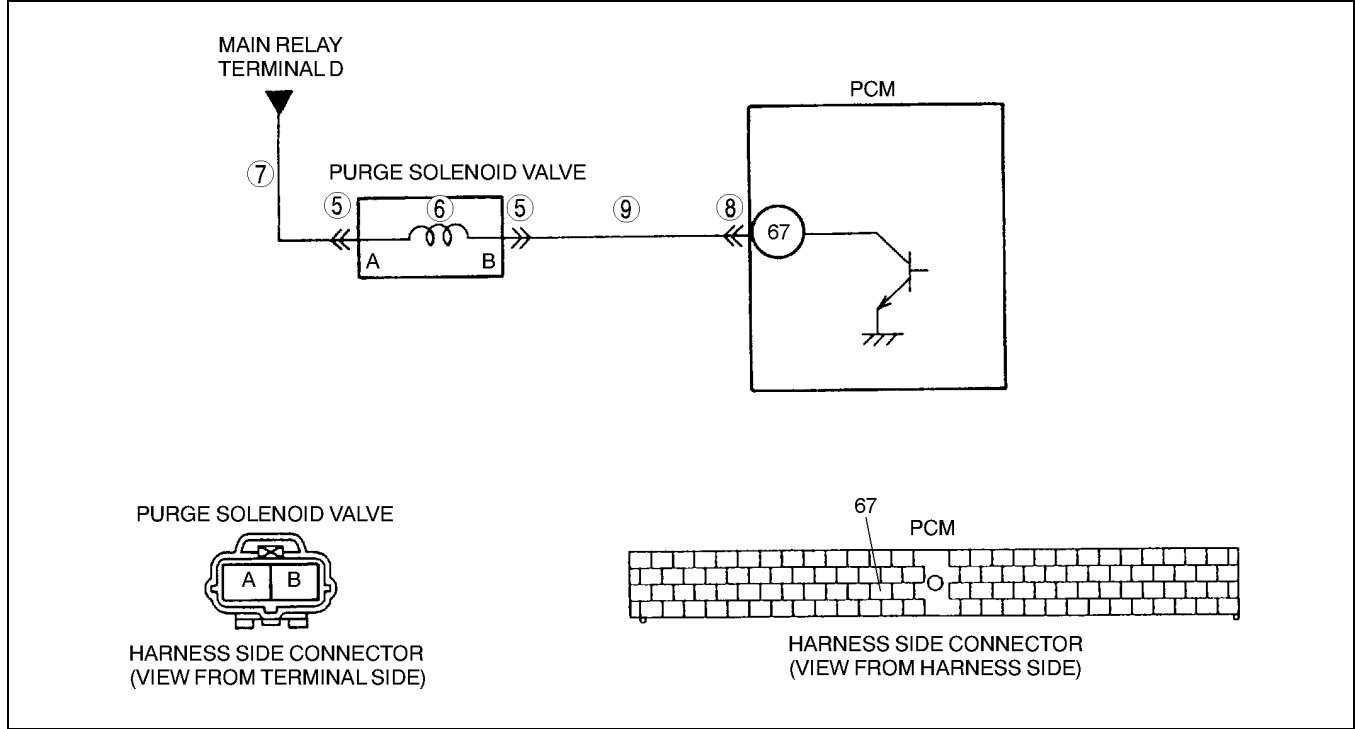

**Diagnostic procedure**

STEP	INSPECTION		ACTION
1	<b>VERIFY RELATED REPAIR INFORMATION AVAILABILITY</b> <ul style="list-style-type: none"> <li>Check for related Service Bulletins availability.</li> <li>Is any related repair information available?</li> </ul>	Yes	Perform repair or diagnosis according to available repair information. <ul style="list-style-type: none"> <li>If vehicle is not repaired, go to next step.</li> </ul>
		No	Go to next step.
2	<b>CLASSIFY INTERMITTENT CONCERN OR CONTINUOUS CONCERN</b> <ul style="list-style-type: none"> <li>Turn ignition key to OFF then start engine.</li> <li>Is same DTC present?</li> </ul>	Yes	Go to next step.
		No	Refer to intermittent concern. (See 01-03B-4 INTERMITTENT CONCERN TROUBLESHOOTING [FS].)
3	<b>CLASSIFY OPEN CIRCUIT OR SHORT TO GROUND MALFUNCTION</b> <ul style="list-style-type: none"> <li>Disconnect purge solenoid valve tube that is connected to intake manifold.</li> <li>Connect vacuum pump to purge solenoid valve.</li> <li>Pump vacuum pump several times and stop.</li> <li>Wait a few seconds.</li> <li>Is vacuum maintained?</li> </ul>	Yes	Go to Step 5.
		No	Go to next step.

## ON-BOARD DIAGNOSTIC [ENGINE CONTROL SYSTEM (FS)]

STEP	INSPECTION	ACTION
4	<b>INSPECT PASSAGE CONTROL OF PURGE SOLENOID VALVE</b> <ul style="list-style-type: none"> <li>• Turn ignition key to OFF.</li> <li>• Disconnect purge solenoid valve connector.</li> <li>• Pump vacuum pump several times and wait a <b>few seconds</b>.</li> <li>• Is vacuum maintained?</li> </ul>	Yes Repair or replace harness for short to ground, then go to Step 10.
		No Replace purge solenoid valve, then go to Step 10.
5	<b>INSPECT PURGE SOLENOID VALVE CONNECTOR FOR POOR CONNECTION</b> <ul style="list-style-type: none"> <li>• Turn ignition key to OFF.</li> <li>• Check for poor connection (damaged/pulled-out pins, corrosion, etc.).</li> <li>• Is there malfunction?</li> </ul>	Yes Repair or replace terminal, then go to Step 10.
		No Go to next step.
6	<b>INSPECT PURGE SOLENOID VALVE</b> <ul style="list-style-type: none"> <li>• Measure resistance between purge solenoid valve terminals (part-side).</li> <li>• Is resistance <b>within 22—26 ohms</b>?</li> </ul>	Yes Go to next step.
		No Replace purge solenoid valve, then go to Step 10.
7	<b>INSPECT PURGE SOLENOID VALVE POWER SUPPLY CIRCUIT FOR OPEN CIRCUIT</b> <ul style="list-style-type: none"> <li>• Turn ignition key to ON (Engine OFF).</li> <li>• Measure voltage between purge solenoid valve connector terminal A and body ground.</li> <li>• Is voltage <b>B+</b>?</li> </ul>	Yes Go to next step.
		No Repair or replace harness for open, then go to Step 10.
8	<b>INSPECT PCM CONNECTOR FOR POOR CONNECTION</b> <ul style="list-style-type: none"> <li>• Turn ignition key to OFF.</li> <li>• Disconnect PCM connector.</li> <li>• Check for poor connection (damaged/pulled-out pins, corrosion, etc.).</li> <li>• Is there malfunction?</li> </ul>	Yes Repair or replace terminal, then go to Step 10.
		No Go to next step.
9	<b>INSPECT PURGE SOLENOID VALVE CONTROL CIRCUIT</b> <ul style="list-style-type: none"> <li>• Connect breakout box with PCM disconnected.</li> <li>• Turn ignition key to ON (Engine OFF).</li> <li>• Measure voltage between purge solenoid valve terminal B (harness-side) and body ground.</li> <li>• Is voltage <b>B+</b>?</li> </ul>	Yes Repair or replace harness for short to power, then go to next step.
		No Check for continuity between purge solenoid valve terminal B (harness-side) and breakout box terminal 67. <ul style="list-style-type: none"> <li>• If there is continuity, go to next step.</li> <li>• If there is no continuity, repair or replace harness for open, then go to next step.</li> </ul>
10	<b>VERIFY TROUBLESHOOTING OF DTC P0443 COMPLETED</b> <ul style="list-style-type: none"> <li>• Make sure to reconnect all disconnected connectors.</li> <li>• Turn ignition key to OFF then start engine.</li> <li>• Is same DTC present?</li> </ul>	Yes Replace PCM, then go to next step.
		No Go to next step.
11	<b>VERIFY AFTER REPAIR PROCEDURE</b> <ul style="list-style-type: none"> <li>• Perform "After Repair Procedure". (See 01-02B-9 AFTER REPAIR PROCEDURE [FS].)</li> <li>• Is there any DTC present?</li> </ul>	Yes Go to applicable DTC inspection. (See 01-02B-15 DTC TABLE [FS].)
		No Troubleshooting completed.

### DTC P0451 [FS]

A3U010201086W06

DTC P0451	Fuel tank pressure sensor performance problem
<b>DETECTION CONDITION</b>	<ul style="list-style-type: none"> <li>• Difference in fuel tank pressure, which PCM monitors while operating evaporative leak monitor function or purge solenoid valve is intentionally closed, is too small or too large.</li> </ul> <p><b>Diagnostic support note</b></p> <ul style="list-style-type: none"> <li>• This is a continuous monitor (CCM).</li> <li>• MIL illuminates if PCM detects the above malfunction condition in two consecutive drive cycles.</li> <li>• PENDING CODE is available if PCM detects the above malfunction condition during first drive cycle.</li> <li>• FREEZE FRAME DATA is available.</li> <li>• DTC is stored in PCM memory.</li> </ul>

## ON-BOARD DIAGNOSTIC [ENGINE CONTROL SYSTEM (FS)]

<b>DTC P0451</b>	<b>Fuel tank pressure sensor performance problem</b>
<b>POSSIBLE CAUSE</b>	<ul style="list-style-type: none"> <li>• Fuel tank pressure sensor malfunction</li> <li>• Purge solenoid valve malfunction</li> <li>• CDCV malfunction</li> <li>• Poor connection of CDCV, fuel tank pressure sensor and/or PCM</li> <li>• Short circuit in wiring at CDCV</li> <li>• Charcoal canister clogging</li> </ul>

01-02B

### Diagnostic procedure

STEP	INSPECTION		ACTION
1	<b>VERIFY FREEZE FRAME DATA HAS BEEN RECORDED</b> • Has FREEZE FRAME DATA been recorded?	Yes	Go to next step.
		No	Record FREEZE FRAME DATA on repair order, then go to next step.
2	<b>VERIFY RELATED REPAIR INFORMATION AVAILABILITY</b> • Check for related Service Bulletins availability. • Is any related repair information available?	Yes	Perform repair or diagnosis according to available repair information. • If vehicle is not repaired, go to next step.
		No	Go to next step.
3	<b>INSPECT FOR OTHER DTCS</b> • Turn ignition key to OFF then start engine. • Verify stored DTC. • Have DTCs P0443 and/or P1449 been stored?	Yes	Go to appropriate DTC inspection.
		No	Go to next step.
4	<b>INSPECT PURGE SOLENOID VALVE OPERATION</b> • Inspect purge solenoid valve. (See 01-16-12 PURGE SOLENOID VALVE INSPECTION.) • Is purge solenoid valve okay?	Yes	Go to next step.
		No	Replace purge solenoid valve, then go to Step 8.
5	<b>INSPECT CDCV OPERATION</b> • Inspect CDCV. (See 01-16-10 CANISTER DRAIN CUT VALVE (CDCV) INSPECTION.) • Is CDCV okay?	Yes	Go to next step.
		No	Replace CDCV, then go to Step 8.
6	<b>INSPECT CHARCOAL CANISTER FOR CLOGGING</b> • Remove charcoal canister and inspect for clogging. (See 01-16-9 CHARCOAL CANISTER INSPECTION.) • Is it okay?	Yes	Go to next step.
		No	Replace charcoal canister, then go to Step 8.
7	<b>INSPECT FUEL TANK PRESSURE SENSOR</b> • Inspect fuel tank pressure sensor. (See 01-40B-40 FUEL TANK PRESSURE SENSOR INSPECTION [FS].) • Is it okay?	Yes	Go to next step.
		No	Replace fuel tank pressure sensor, then go to Step 8.
8	<b>VERIFY MONITORING CONDITION FOR EVAPORATIVE SYSTEM TEST</b> • Turn ignition key to ON (Engine OFF). • Verify that following conditions are met. — ECT (at engine start): <b>-10—35 °C {14.0—95.0 °F}</b> — BARO: <b>Above 69.7kPa {523 mmHg, 20.5 inHg}</b> — VSS: <b>39.5—105.5 km/h {24.5—65.4 mph}</b> — Load: <b>9—65%</b> — TP: <b>0.15—0.85 %</b> — IAT: <b>-10—60 °C {14—140 °F}</b> • Is there any condition that is out of specification?	Yes	Take corrective action (e.g. cool down engine), then repeat this step.  <b>Note</b> • Readings need to be in the indicated ranges to perform Drive Mode.
		No	Correct condition, then go to next step.

## ON-BOARD DIAGNOSTIC [ENGINE CONTROL SYSTEM (FS)]

STEP	INSPECTION	ACTION	
9	<b>MONITOR EVAP SYSTEM BY DRIVE MODE 4</b> <ul style="list-style-type: none"> <li>• Make sure to reconnect all disconnected connectors.</li> <li>• Clear DTC from PCM memory using WDS or equivalent.</li> <li>• Run OBD-II Drive Mode 4. (See 01-02B-12 Mode 4 (EVAP system repair verification drive mode).)</li> <li>• Stop vehicle and access ON BOARD SYSTEM READINESS TESTS to inspect Drive Mode completion status.</li> <li>• Has EVAPORATIVE PURGE SYSTEM been monitored?</li> </ul>	Yes	Go to next step.
		No	Go back to Step 8.
10	<b>VERIFY TROUBLESHOOTING OF DTC P0451 COMPLETED</b> <ul style="list-style-type: none"> <li>• Turn ignition key to ON (Engine OFF).</li> <li>• Is pending code of same DTC present?</li> </ul>	Yes	Replace PCM, then go to next step.
		No	Go to next step.
11	<b>VERIFY AFTER REPAIR PROCEDURE</b> <ul style="list-style-type: none"> <li>• Perform "After Repair Procedure". (See 01-02B-9 AFTER REPAIR PROCEDURE [FS].)</li> <li>• Is there any DTC present?</li> </ul>	Yes	Go to applicable DTC inspection. (See 01-02B-15 DTC TABLE [FS].)
		No	Troubleshooting completed.

# ON-BOARD DIAGNOSTIC [ENGINE CONTROL SYSTEM (FS)]

DTC P0452 [FS]

A3U010201086W07

01-02B

<b>DTC P0452</b>	<b>Fuel tank pressure sensor circuit low input</b>
<b>DETECTION CONDITION</b>	<ul style="list-style-type: none"> <li>PCM monitors input voltage from fuel tank pressure sensor when monitoring condition is met. If PCM terminal 62 voltage is <b>below 0.20 V</b> after engine is started, PCM determines that fuel tank pressure sensor circuit is malfunctioning.</li> </ul> <p><b>MONITORING CONDITION</b></p> <ul style="list-style-type: none"> <li>— Engine coolant temperature is <b>below 80 °C {176 °F}</b>.</li> </ul> <p><b>Diagnostic support note</b></p> <ul style="list-style-type: none"> <li>This is a continuous CCM monitor (CCM).</li> <li>MIL illuminates if PCM detects the above malfunction condition in two consecutive drive cycles.</li> <li>PENDING CODE is available if PCM detects the above malfunction condition during first drive cycle.</li> <li>FREEZE FRAME DATA is available.</li> <li>DTC is stored in PCM memory.</li> </ul>
<b>POSSIBLE CAUSE</b>	<ul style="list-style-type: none"> <li>Fuel tank pressure sensor malfunction</li> <li>Connector or terminal malfunction</li> <li>Short to ground in wiring harness between fuel tank pressure sensor terminal B and PCM terminal 62</li> <li>Open circuit in wiring harness between fuel tank pressure sensor terminal C and PCM terminal 90</li> <li>PCM malfunction</li> </ul>

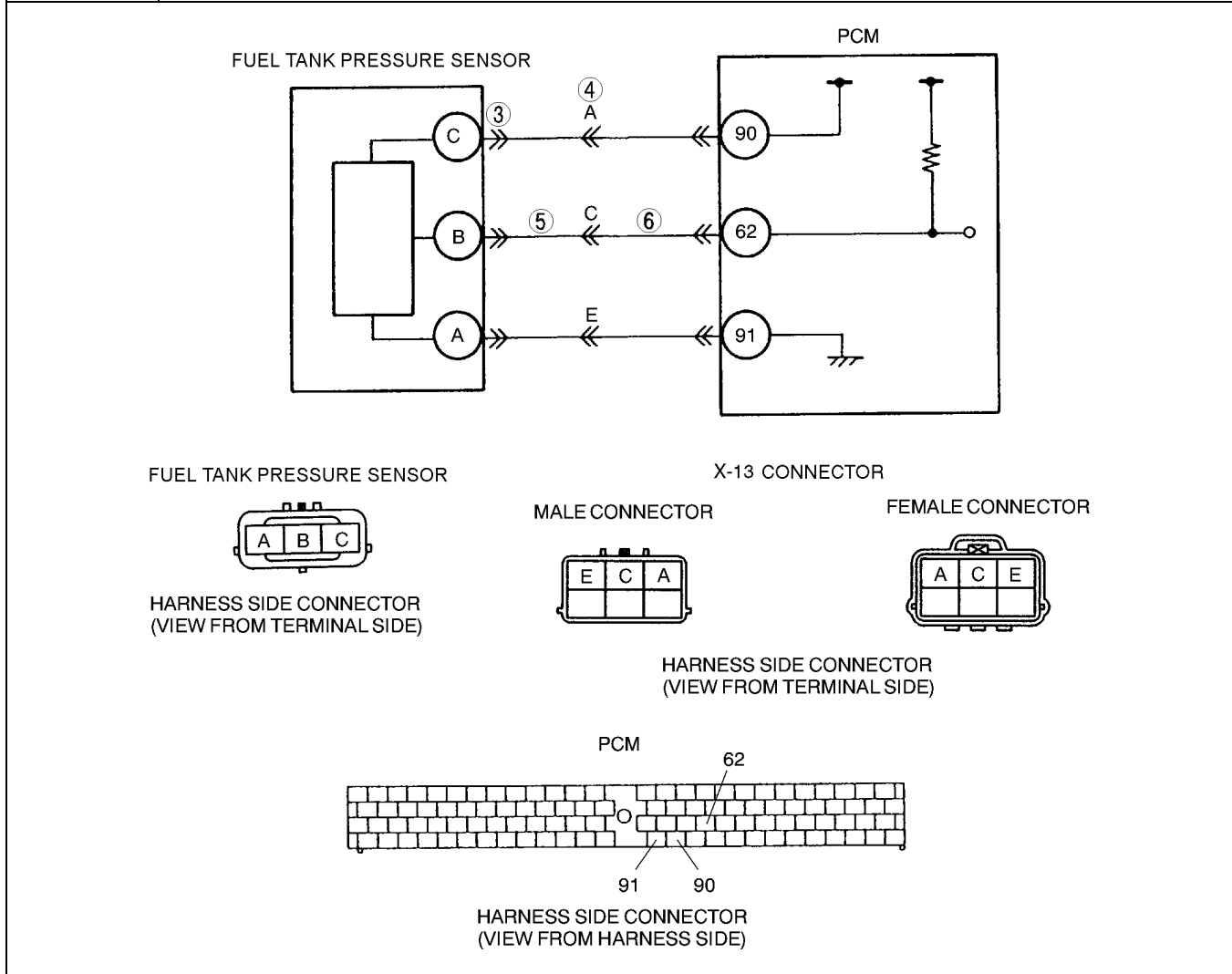

**Diagnostic procedure**

STEP	INSPECTION		ACTION
1	<b>VERIFY FREEZE FRAME DATA HAS BEEN RECORDED</b> <ul style="list-style-type: none"> <li>Has FREEZE FRAME DATA been recorded?</li> </ul>	Yes	Go to next step.
		No	Record FREEZE FRAME DATA on repair order, then go to next step.
2	<b>VERIFY RELATED REPAIR INFORMATION AVAILABILITY</b> <ul style="list-style-type: none"> <li>Check for related Service Bulletins availability.</li> <li>Is any related repair information available?</li> </ul>	Yes	Perform repair or diagnosis according to available repair information. <ul style="list-style-type: none"> <li>If vehicle is not repaired, go to next step.</li> </ul>
		No	Go to next step.

## ON-BOARD DIAGNOSTIC [ENGINE CONTROL SYSTEM (FS)]

STEP	INSPECTION	ACTION	
3	<b>CHECK POWER SUPPLY CIRCUIT VOLTAGE AT FUEL TANK PRESSURE SENSOR CONNECTOR</b>  <b>Note</b> <ul style="list-style-type: none"> <li>• If DTCs P0107 and P0122 are also retrieved with P0452, go to REFERENCE VOLTAGE troubleshooting procedure. (See 01-03B-49 NO.30 REFERENCE VOLTAGE [FS].)</li> <li>• Turn ignition key to ON (Engine OFF).</li> <li>• Check voltage between FTP sensor terminal C (harness-side) and body ground.</li> <li>• Is voltage <b>within 4.5—5.5 V</b>?</li> </ul>	Yes	Go to Step 5.
		No	Go to next step.
4	<b>CHECK POWER SUPPLY CIRCUIT VOLTAGE AT FUEL TANK PRESSURE SENSOR INTERMEDIATE CONNECTOR</b> <ul style="list-style-type: none"> <li>• Disconnect X-13 connector.</li> <li>• Measure voltage at X-13 male terminal A.</li> <li>• Is voltage <b>within 4.5—5.5 V</b>?</li> </ul>	Yes	Check for open circuit between following terminals: <ul style="list-style-type: none"> <li>• X-13 connector female terminal A and fuel tank pressure sensor terminal C (harness-side)</li> <li>— Repair or replace suspected harness, then go to Step 7.</li> </ul>
		No	Check for open circuit between following terminals: <ul style="list-style-type: none"> <li>• PCM terminal 90 (harness-side) and X-13 connector male terminal A.</li> <li>— Repair or replace suspected harness, then go to Step 7.</li> </ul>
5	<b>INSPECT FTP SIGNAL CIRCUIT FOR SHORT TO GROUND (FUEL TANK PRESSURE SENSOR CONNECTOR AND X-13 INTERMEDIATE CONNECTOR)</b> <ul style="list-style-type: none"> <li>• Turn ignition key to OFF.</li> <li>• Disconnect X-13 connector.</li> <li>• Check for continuity between X-13 female terminal C and ground.</li> <li>• Is there continuity?</li> </ul>	Yes	Repair or replace suspected harness, then go to Step 7.
		No	Go to next step.
6	<b>INSPECT FTP SIGNAL CIRCUIT FOR SHORT TO GROUND (PCM CONNECTOR AND X-13 INTERMEDIATE CONNECTOR)</b> <ul style="list-style-type: none"> <li>• Disconnect PCM connector.</li> <li>• Check for continuity between X-13 male terminal C (harness-side) and body ground.</li> <li>• Is there continuity?</li> </ul>	Yes	Repair or replace suspected harness, then go to next step.
		No	Check fuel tank pressure sensor signal circuit and fuel tank pressure sensor ground circuit for shorts. Repair or replace suspected harness, then go to next step.
7	<b>VERIFY TROUBLESHOOTING OF DTC P0452 COMPLETED</b> <ul style="list-style-type: none"> <li>• Make sure to reconnect all disconnected connectors.</li> <li>• Turn ignition key to ON (Engine OFF).</li> <li>• Clear DTC from memory using WDS or equivalent.</li> <li>• Start engine.</li> <li>• Is pending code of same DTC present?</li> </ul>	Yes	Replace PCM, then go to next step.
		No	Go to next step.
8	<b>VERIFY AFTER REPAIR PROCEDURE</b> <ul style="list-style-type: none"> <li>• Perform "After Repair Procedure". (See 01-02B-9 AFTER REPAIR PROCEDURE [FS].)</li> <li>• Is there any DTC present?</li> </ul>	Yes	Go to applicable DTC inspection. (See 01-02B-15 DTC TABLE [FS].)
		No	Troubleshooting completed.

# ON-BOARD DIAGNOSTIC [ENGINE CONTROL SYSTEM (FS)]

DTC P0453 [FS]

A3U010201086W08

01-02B

<b>DTC P0453</b>	<b>Fuel tank pressure sensor circuit high input</b>
<b>DETECTION CONDITION</b>	<ul style="list-style-type: none"> <li>PCM monitors input voltage from FUEL TANK PRESSURE sensor when monitoring condition is met. If PCM terminal voltage is <b>above 4.79 V</b> after engine is started, PCM determines that FUEL TANK PRESSURE sensor circuit has malfunction.</li> </ul> <p><b>MONITORING CONDITION</b> — Engine coolant temperature is <b>below 80 °C {176 °F}</b>.</p> <p><b>Diagnostic support note</b></p> <ul style="list-style-type: none"> <li>This is a continuous monitor (CCM).</li> <li>MIL illuminates if PCM detects the above malfunction condition in two consecutive drive cycles.</li> <li>PENDING CODE is available if PCM detects the above detection condition during first drive cycle.</li> <li>FREEZE FRAME DATA is available.</li> <li>DTC is stored in PCM memory.</li> </ul>
<b>POSSIBLE CAUSE</b>	<ul style="list-style-type: none"> <li>FUEL TANK PRESSURE sensor malfunction</li> <li>Connector or terminal malfunction</li> <li>Open circuit in wiring between fuel tank pressure sensor terminal B and PCM terminal 62</li> <li>Open circuit in wiring between from fuel tank pressure sensor terminal A and PCM terminal 91</li> <li>FUEL TANK PRESSURE sensor signal circuit is shorted to reference voltage (Vref) supply circuit.</li> </ul>

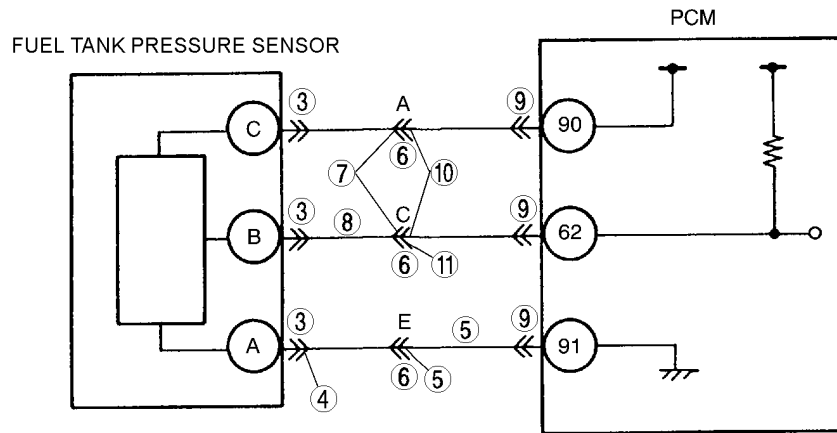

FUEL TANK PRESSURE SENSOR

X-13 CONNECTOR

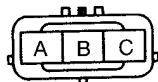

HARNESS SIDE CONNECTOR  
(VIEW FROM TERMINAL SIDE)

MALE CONNECTOR



HARNESS SIDE CONNECTOR  
(VIEW FROM TERMINAL SIDE)

FEMALE CONNECTOR

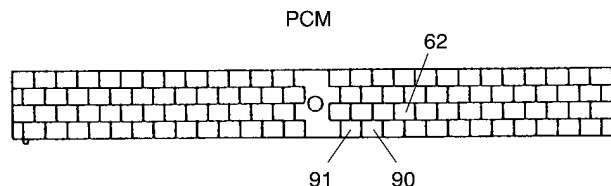

HARNESS SIDE CONNECTOR  
(VIEW FROM HARNESS SIDE)

**Diagnostic procedure**

STEP	INSPECTION	Yes/No	ACTION
1	<b>VERIFY FREEZE FRAME DATA HAS BEEN RECORDED</b> <ul style="list-style-type: none"> <li>Has FREEZE FRAME DATA been recorded?</li> </ul>	Yes  No	Go to next step. Record FREEZE FRAME DATA on repair order, then go to next step.

## ON-BOARD DIAGNOSTIC [ENGINE CONTROL SYSTEM (FS)]

STEP	INSPECTION	ACTION	
2	<b>VERIFY RELATED REPAIR INFORMATION AVAILABILITY</b> <ul style="list-style-type: none"> <li>• Check for related Service Bulletins availability.</li> <li>• Is any related repair information available?</li> </ul>	Yes	Perform repair or diagnosis according to available repair information. <ul style="list-style-type: none"> <li>• If vehicle is not repaired, go to next step.</li> </ul>
		No	Go to next step.
3	<b>INSPECT FUEL TANK PRESSURE SENSOR CONNECTOR FOR POOR CONNECTION</b> <ul style="list-style-type: none"> <li>• Turn ignition key to OFF.</li> <li>• Disconnect FTP sensor connector.</li> <li>• Check for poor connection (damaged/pulled-out terminals, corrosion, etc.).</li> <li>• Is there malfunction?</li> </ul>	Yes	Repair or replace suspected terminal, then go to Step 12.
		No	Go to next step.
4	<b>INSPECT FUEL TANK PRESSURE SENSOR GROUND CIRCUIT FOR OPEN CIRCUIT (AT FUEL TANK PRESSURE SENSOR CONNECTOR)</b> <ul style="list-style-type: none"> <li>• Check for continuity between fuel tank pressure sensor terminal A (harness-side) and body ground.</li> <li>• Is there continuity?</li> </ul>	Yes	Go to Step 6.
		No	Go to next step.
5	<b>INSPECT FUEL TANK PRESSURE SENSOR GROUND CIRCUIT FOR OPEN CIRCUIT (AT X-13 CONNECTOR)</b> <ul style="list-style-type: none"> <li>• Disconnect X-13 connector.</li> <li>• Check for continuity between X-13 male terminal E and body ground.</li> <li>• Is there continuity?</li> </ul>	Yes	Check for open circuit between following terminals: <ul style="list-style-type: none"> <li>• X-13 female terminal E and FTP sensor terminal A (harness-side)</li> </ul> Repair or replace suspected harness, then go to Step 12.
		No	Check for open circuit between following terminals: <ul style="list-style-type: none"> <li>• PCM terminal 91 (harness-side) and X-13 male terminal E</li> </ul> Repair or replace suspected harness, then go to Step 12.
6	<b>CHECK 6-PIN INTERMEDIATE CONNECTOR</b> <ul style="list-style-type: none"> <li>• Disconnect X-13 connector.</li> <li>• Check for poor connection (damaged/pulled-out pins, corrosion, etc.).</li> <li>• Is there malfunction?</li> </ul>	Yes	Repair or replace suspected terminal, then go to Step 12.
		No	Go to next step.
7	<b>INSPECT FUEL TANK PRESSURE SIGNAL CIRCUIT FOR SHORT TO CONSTANT VOLTAGE CIRCUIT (FUEL TANK PRESSURE SENSOR CONNECTOR AND X-13 CONNECTOR)</b> <ul style="list-style-type: none"> <li>• Check for continuity between X-13 female terminals A and C.</li> <li>• Is there continuity?</li> </ul>	Yes	Repair or replace suspected harness, then go to Step 12.
		No	Go to next step.
8	<b>INSPECT FUEL TANK PRESSURE SIGNAL CIRCUIT FOR OPEN CIRCUIT (FUEL TANK PRESSURE SENSOR CONNECTOR AND X-13 CONNECTOR)</b> <ul style="list-style-type: none"> <li>• Check for continuity between fuel tank pressure sensor terminal B (harness-side) and X-13 female terminal C.</li> <li>• Is there continuity?</li> </ul>	Yes	Go to next step.
		No	Repair or replace suspected harness, then go to Step 12.
9	<b>INSPECT PCM CONNECTOR FOR POOR CONNECTION</b> <ul style="list-style-type: none"> <li>• Disconnect PCM connector.</li> <li>• Check for poor connection at terminals 62, 90 and 91 (damaged/pulled-out terminals, corrosion, etc.).</li> <li>• Is there malfunction?</li> </ul>	Yes	Repair terminal, then go to Step 12.
		No	Go to next step.
10	<b>INSPECT FUEL TANK PRESSURE SIGNAL CIRCUIT FOR SHORT TO CONSTANT VOLTAGE CIRCUIT (X-13 CONNECTOR AND PCM CONNECTOR)</b> <ul style="list-style-type: none"> <li>• Check for continuity between X-13 terminals A and C (PCM-side).</li> <li>• Is there continuity?</li> </ul>	Yes	Repair or replace suspected harness, then go to Step 12.
		No	Go to next step.



## ON-BOARD DIAGNOSTIC [ENGINE CONTROL SYSTEM (FS)]

STEP	INSPECTION	ACTION
11	<b>INSPECT FUEL TANK PRESSURE SIGNAL CIRCUIT FOR OPEN CIRCUIT (X-13 CONNECTOR AND PCM CONNECTOR)</b> <ul style="list-style-type: none"> <li>• Connect breakout box with PCM disconnected.</li> <li>• Check for continuity between X-13 male terminal C (PCM-side) and breakout box terminal 62.</li> <li>• Is there continuity?</li> </ul>	Yes Go to next step.
		No Repair or replace suspected harness, then go to next step.
12	<b>VERIFY TROUBLESHOOTING OF DTC P0453 COMPLETED</b> <ul style="list-style-type: none"> <li>• Make sure to reconnect all disconnected connectors.</li> <li>• Turn ignition key ON (Engine OFF).</li> <li>• Clear DTC from memory using WDS or equivalent.</li> <li>• Start engine.</li> <li>• Is pending code of same DTC present?</li> </ul>	Yes Replace PCM, then go to next step.
		No Go to next step.
13	<b>VERIFY AFTER REPAIR PROCEDURE</b> <ul style="list-style-type: none"> <li>• Perform "After Repair Procedure". (See 01-02B-9 AFTER REPAIR PROCEDURE [FS].)</li> <li>• Is there any DTC present?</li> </ul>	Yes Go to applicable DTC inspection. (See 01-02B-15 DTC TABLE [FS].)
		No Troubleshooting completed.

01-02B

### DTC P0455 [FS]

A3U010201086W09

DTC P0455	Evaporative emission control system leak detected (blockage or large leak)
<b>DETECTION CONDITION</b>	<ul style="list-style-type: none"> <li>• PCM measures the fuel tank pressure (ftp1), which is the vacuum when a specified period has passed after the tank pressure has reached the preprogrammed target pressure and purge control valve has been closed when monitoring conditions are met. If fuel tank pressure is above threshold, PCM determines that the EVAP system is blocked or has a large leak.</li> </ul> <p><b>THRESHOLD VALUE</b></p> <ul style="list-style-type: none"> <li>— Fuel tank pressure (ftp1): <b>-1.3—1.95 kPa {-9.76—14.65 mmHg, -0.38—0.58 inHg}</b> <ul style="list-style-type: none"> <li>• Threshold valve varies depends on ECT at engine start BARO.</li> </ul> </li> </ul> <p><b>MONITORING CONDITIONS</b></p> <ul style="list-style-type: none"> <li>— Fuel tank pressure (ftp 1): <b>above -3.92 kPa {-29.42 mmHg, -1.16 inHg}</b></li> <li>— PCM monitors EVAP system when driving under following conditions:                             <ul style="list-style-type: none"> <li>• Remaining fuel: <b>35—85%</b></li> <li>• ECT at engine start: <b>-10—35 °C {14.0—95.0 °F}</b></li> <li>• Atmospheric pressure: <b>above 69.7 kPa {523 mmHg, 20.5 inHg}</b></li> <li>• Vehicle speed: <b>39.5—120.3 km/h {24.5—74.7 mph}</b></li> <li>• Engine speed: <b>1,000—4,000 rpm</b></li> <li>• Calculated load: <b>9—65%</b></li> <li>• Throttle opening angle: <b>3.1—12.5%</b></li> <li>• IAT during monitor: <b>-10—60 °C {14—140 °F}</b></li> </ul> </li> </ul> <p><b>Diagnostic support note</b></p> <ul style="list-style-type: none"> <li>• This is an intermittent monitor (Evaporative leak monitor).</li> <li>• MIL illuminates if PCM detects the above malfunction condition in two consecutive drive cycles.</li> <li>• DIAGNOSTIC MONITORING TEST RESULTS and PENDING CODE are available if PCM detects the above malfunction condition during first drive cycle.</li> <li>• FREEZE FRAME DATA is available.</li> <li>• DTC is stored in PCM memory.</li> </ul>
<b>POSSIBLE CAUSE</b>	<ul style="list-style-type: none"> <li>• Purge solenoid valve malfunction</li> <li>• Canister drain cut valve (CDCV) malfunction</li> <li>• Loose, missing or defective fuel filler cap</li> <li>• Charcoal canister malfunction</li> <li>• Catch tank malfunction</li> <li>• Check valve malfunction</li> <li>• Rollover valve malfunction</li> <li>• Cracked fuel tank</li> <li>• Fuel tank component parts poorly installed</li> <li>• EVAP hose damaged or loose</li> <li>• Fuel tank pressure sensor malfunction</li> </ul>

## ON-BOARD DIAGNOSTIC [ENGINE CONTROL SYSTEM (FS)]

### Diagnostic procedure

STEP	INSPECTION	ACTION
1	<b>VERIFY FREEZE FRAME DATA HAS BEEN RECORDED</b> <ul style="list-style-type: none"> <li>Has FREEZE FRAME DATA been recorded?</li> </ul>	Yes Go to next step.
		No Record FREEZE FRAME DATA on repair order, then go to next step.
2	<b>VERIFY RELATED REPAIR INFORMATION AVAILABILITY</b> <ul style="list-style-type: none"> <li>Check for related Service Bulletins availability.</li> <li>Is any related repair information available?</li> </ul>	Yes Perform repair or diagnosis according to available repair information. <ul style="list-style-type: none"> <li>If vehicle is not repaired, go to next step.</li> </ul>
		No Go to next step.
3	<b>VERIFY RELATED PENDING CODE OR STORED DTCS</b> <ul style="list-style-type: none"> <li>Turn ignition key to OFF then ON (Engine OFF).</li> <li>Verify related PENDING CODE or stored DTCS.</li> <li>DTCS P0443 and/or P1449 present?</li> </ul>	Yes Go to appropriate DTC inspection.
		No Go to next step.
4	<b>INSPECT FUEL-FILLER CAP</b> <ul style="list-style-type: none"> <li>Verify fuel-filler cap is not either disconnected, loose or damaged.</li> <li>Is it okay?</li> </ul> <p><b>Note</b></p> <ul style="list-style-type: none"> <li>When fuel-filler caps other than OEM caps are attached, it is considered malfunction.</li> </ul>	Yes Go to next step.
		No Retighten fuel-filler cap or replace it if it is damaged. Then go to Step 27.
5	<b>INSPECT PURGE SOLENOID VALVE STUCK</b> <ul style="list-style-type: none"> <li>Inspect purge solenoid valve (See 01-16-12 PURGE SOLENOID VALVE INSPECTION.)</li> <li>Is purge solenoid valve okay?</li> </ul>	Yes Go to next step.
		No Replace purge solenoid valve, then go to Step 27.
6	<b>INSPECT CDCV STUCK</b> <ul style="list-style-type: none"> <li>Inspect CDCV. (See 01-16-10 CANISTER DRAIN CUT VALVE (CDCV) INSPECTION.)</li> <li>Is CDCV okay?</li> </ul>	Yes Go to next step.
		No Replace CDCV, then go to Step 27.
7	<b>CLASSIFY EVAPORATIVE EMISSION CONTROL SYSTEM FOR LEAKAGE OR BLOCKAGE</b> <p><b>Note</b></p> <ul style="list-style-type: none"> <li>If evaporative emission tester is not available, go to next step.</li> </ul> <ul style="list-style-type: none"> <li>Carry out evaporative emission control system inspection using evaporative emission tester. (See 01-03B-54 Evaporative System Leak Inspection Using Leak Tester.)</li> <li>Does red "FAILED" light turn ON (leakage)?</li> </ul>	Yes Tester detects leakage. <ul style="list-style-type: none"> <li>Inspect evaporative control system for leakage using evaporative emission tester. (See 01-03B-54 Evaporative System Leak Inspection Using Leak Tester.)</li> <li>Repair or replace faulty area, then go to Step 27.</li> </ul>
		No Go to next step.
8	<b>VERIFY REPAIR SHOP CONDITION</b> <ul style="list-style-type: none"> <li>Is repair shop possible to perform Drive Mode 4?</li> </ul>	Yes Go to next step.
		No Go to Step 16.
9	<b>VERIFY MONITORING CONDITION FOR DRIVE MODE 4</b> <ul style="list-style-type: none"> <li>Turn ignition key to ON (Engine OFF).</li> <li>Verify that following conditions are met.                             <ul style="list-style-type: none"> <li>Barometric pressure: <b>69.7 kPa {523 mmHg, 20.5 inHg} or higher</b></li> <li>Engine coolant temperature: <b>-10.0—20.0 °C {14.0—68.0 °F}</b> [at barometric pressure <b>69.7 kPa {523 mmHg, 20.5 inHg}</b>]</li> <li>Intake air temperature: <b>-10—60 °C {50—140 °F}</b></li> <li>Fuel tank level: <b>35—85%</b></li> </ul> </li> <li>Is there any conditions that is out of specification?</li> </ul>	Yes Take corrective action (e.g. cool down engine), then repeat this step. <p><b>Note</b></p> <ul style="list-style-type: none"> <li>Readings need to be in the indicated ranges to perform Drive Mode.</li> </ul>
		No Go to next step.

## ON-BOARD DIAGNOSTIC [ENGINE CONTROL SYSTEM (FS)]

STEP	INSPECTION	ACTION
10	<b>MONITOR EVAP SYSTEM BY DRIVE MODE 4</b> <ul style="list-style-type: none"> <li>• Clear DTC from memory using WDS or equivalent.</li> <li>• Run OBD-II Drive Mode 4 and verify that CDCV and FTP graphs. (See 01-02B-12 Mode 4 (EVAP system repair verification drive mode).)</li> <li>• Is there any problem detected?</li> </ul>	Yes FTP does not change: <ul style="list-style-type: none"> <li>• EVAP monitoring system is inoperative. Go to next step.</li> </ul> FTP changes, but does not reach <b>2.0 kPa {15 mmHg, 0.59 inHg}</b> : <ul style="list-style-type: none"> <li>• There is a large leak in EVAP system. Go to Step 13.</li> </ul> FTP reaches <b>2.0 kPa {15 mmHg, 0.59 inHg}</b> , but suddenly goes back: <ul style="list-style-type: none"> <li>• Pressure in fuel tank cannot be reduced and only gas from EVAP line can be drawn.</li> </ul> Inspect following and repair or replace suspected parts. <ul style="list-style-type: none"> <li>• Rollover valve for large ventilation resistance.</li> <li>• Check valve for inoperative or blockage.</li> <li>• Air filter for clogging.</li> </ul> Then go to Step 27.
		No No leaks were detected in EVAP control system at this time. Go to Step 30.
11	<b>INSPECT PURGE SOLENOID VALVE OPERATION</b> <ul style="list-style-type: none"> <li>• Inspect purge solenoid valve (See 01-16-12 PURGE SOLENOID VALVE INSPECTION.)</li> <li>• Is purge solenoid valve okay?</li> </ul>	Yes Go to next step.
		No Replace purge solenoid valve, then go to Step 27.
12	<b>INSPECT FUEL TANK PRESSURE SENSOR</b> <ul style="list-style-type: none"> <li>• Inspect fuel tank pressure sensor. (See 01-40B-40 FUEL TANK PRESSURE SENSOR INSPECTION [FS].)</li> <li>• Is fuel tank pressure sensor okay?</li> </ul>	Yes Go to next step.
		No Replace fuel tank pressure sensor, then go to Step 27.
13	<b>INSPECT CATCH TANK</b> <ul style="list-style-type: none"> <li>• Remove catch tank and inspect for plugging, damages and pinhole using vacuum pump.</li> <li>• Is it okay?</li> </ul>	Yes Go to next step.
		No Replace catch tank, then go to Step 27.
14	<b>INSPECT CHARCOAL CANISTER</b> <ul style="list-style-type: none"> <li>• Remove charcoal canister and inspect for damage and pinhole.</li> <li>• Is it okay?</li> </ul>	Yes Go to next step.
		No Replace charcoal canister, then go to Step 27.
15	<b>INSPECT CDCV OPERATION</b> <ul style="list-style-type: none"> <li>• Inspect CDCV. (See 01-16-10 CANISTER DRAIN CUT VALVE (CDCV) INSPECTION.)</li> <li>• Is CDCV okay?</li> </ul>	Yes Go to next step.
		No Replace CDCV, then go to Step 27.
16	<b>INSPECT WHOLE SYSTEM OF EVAP CONTROL SYSTEM</b> <ul style="list-style-type: none"> <li>• Implement "01-03B ENGINE CONTROL SYSTEM OPERATION INSPECTION [FS], Evaporative System Leak Inspection Using Vacuum Pump, Whole system inspection". (See 01-03B-55 Whole system inspection.)</li> <li>• Does voltage change under to specified readings and hold for <b>minimum of 2 minutes</b>?</li> </ul>	Yes Intermittent concern exists. (See 01-03B-4 INTERMITTENT CONCERN TROUBLESHOOTING [FS].) Inspect purge solenoid valve and CDCV circuit.
		No Go to next step.
17	<b>INSPECT FUEL TANK PRESSURE SENSOR</b> <ul style="list-style-type: none"> <li>• Inspect fuel tank pressure sensor. (See 01-40B-40 FUEL TANK PRESSURE SENSOR INSPECTION [FS].)</li> <li>• Is fuel tank pressure sensor okay?</li> </ul>	Yes Go to next step.
		No Replace fuel tank pressure sensor, then go to Step 27.
18	<b>INSPECT LEAKAGE FROM CHARCOAL CANISTER TO FUEL TANK</b> <ul style="list-style-type: none"> <li>• Implement "01-03B ENGINE CONTROL SYSTEM OPERATION INSPECTION [FS], Evaporative System Leak Inspection Using Vacuum Pump, Inspection from charcoal canister to fuel tank". (See 01-03B-55 Inspection from charcoal canister to fuel tank.)</li> <li>• Does voltage change under to specified readings and hold for <b>minimum of 2 minutes</b>?</li> </ul>	Yes Go to Step 22.
		No Go to next step.

01-02B

## ON-BOARD DIAGNOSTIC [ENGINE CONTROL SYSTEM (FS)]

STEP	INSPECTION	ACTION	
19	<b>INSPECT ATTACHED ACCESSORIES ON FUEL TANK</b> <ul style="list-style-type: none"> <li>• Remove fuel tank and visually inspect for damage, insufficient sealing or poorly attached accessories on fuel tank, such as fuel gauge.</li> <li>• Is it okay?</li> </ul>	Yes	Go to next step.
		No	Repair or replace fuel tank or sealing, then go to Step 27.
20	<b>INSPECT FUEL SHUT-OFF VALVE</b> <ul style="list-style-type: none"> <li>• Inspect fuel shut-off valve for ventilation. (See 01-14-13 FUEL TANK INSPECTION.)</li> <li>• Is it okay?</li> </ul>	Yes	Go to next step.
		No	Replace fuel tank, then go to Step 27.
21	<b>INSPECT ROLLOVER VALVE</b> <ul style="list-style-type: none"> <li>• Inspect rollover valve for ventilation.</li> <li>• Is it okay?</li> </ul>	Yes	Inspect following and repair or replace for detached, incorrectly installed or cracked hoses: <ul style="list-style-type: none"> <li>• Charcoal canister</li> <li>• Fuel tank (include fuel shut-off valve and rollover valve)</li> <li>• Fuel tank pressure sensor</li> </ul> Then go to Step 27.
		No	Replace fuel tank, then go to Step 27.
22	<b>INSPECT LEAKAGE FROM CHARCOAL CANISTER TO PURGE SOLENOID VALVE</b> <ul style="list-style-type: none"> <li>• Implement "01-03B ENGINE CONTROL SYSTEM OPERATION INSPECTION [FS], Evaporative Leak System Inspection Using Vacuum Pump, Inspection from charcoal canister to purge solenoid valve". (See 01-03B-55 Inspection from charcoal canister to purge solenoid valve.)</li> <li>• Does voltage change under to specified readings and hold for a <b>minimum of 2 minutes</b>?</li> </ul>	Yes	Go to Step 27.
		No	Go to next step.
23	<b>INSPECT CATCH TANK</b> <ul style="list-style-type: none"> <li>• Remove catch tank and inspect for plugging, damages and pinhole using vacuum pump.</li> <li>• Is it okay?</li> </ul>	Yes	Go to next step.
		No	Replace catch tank, then go to Step 27.
24	<b>INSPECT PURGE SOLENOID VALVE OPERATION</b> <ul style="list-style-type: none"> <li>• Inspect purge solenoid valve (See 01-16-12 PURGE SOLENOID VALVE INSPECTION.)</li> <li>• Is purge solenoid valve okay?</li> </ul>	Yes	Go to next step.
		No	Replace purge solenoid valve, then go to Step 27.
25	<b>INSPECT CHARCOAL CANISTER</b> <ul style="list-style-type: none"> <li>• Remove charcoal canister and inspect for plugging, damage and pinhole.</li> <li>• Is it okay?</li> </ul>	Yes	Go to next step.
		No	Replace charcoal canister, then go to Step 27.
26	<b>INSPECT CDCV OPERATION</b> <ul style="list-style-type: none"> <li>• Inspect CDCV. (See 01-16-10 CANISTER DRAIN CUT VALVE (CDCV) INSPECTION.)</li> <li>• Is CDCV okay?</li> </ul>	Yes	Go to next step.
		No	Replace CDCV, then go to next step.
27	<b>DECIDE ON AFTER REPAIR PROCEDURE ACCORDING TO REPAIR SHOP CONDITION</b> <ul style="list-style-type: none"> <li>• Clear DTC from memory using WDS or equivalent.</li> <li>• Is repair shop possible to perform Drive Mode 4?</li> </ul>	Yes	Go to next step.
		No	Go to step 31.

## ON-BOARD DIAGNOSTIC [ENGINE CONTROL SYSTEM (FS)]

STEP	INSPECTION	ACTION	
28	<b>VERIFY MONITORING CONDITION FOR EVAPORATIVE SYSTEM TEST OR DRIVE MODE 4</b> <ul style="list-style-type: none"> <li>• Turn ignition key to ON (Engine OFF).</li> <li>• Verify that following conditions are met.                             <ul style="list-style-type: none"> <li>— Barometric pressure: <b>69.7 kPa {523 mmHg, 20.5 inHg} or higher</b></li> <li>— Engine coolant temperature: <b>-10.0—22.0 °C {14.0—71.6 °F}</b> [at barometric pressure <b>69.7 kPa {523 mmHg, 20.5 inHg}</b>]</li> <li>— Intake air temperature: <b>-10—60 °C {50—140 °F}</b></li> <li>— Fuel tank level: <b>35—85%</b></li> </ul> </li> <li>• Is there any conditions that is out of specification?</li> </ul>	Yes	Take corrective action (e.g. cool down engine), then repeat this step. <p style="margin-top: 10px;"><b>Note</b></p> <ul style="list-style-type: none"> <li>• Readings need to be in the indicated ranges to perform Drive Mode.</li> </ul>
		No	Go to next step.
29	<b>MONITOR EVAP SYSTEM BY DRIVE MODE 4</b> <ul style="list-style-type: none"> <li>• Run OBD-II Drive Mode 4. (See 01-02B-12 Mode 4 (EVAP system repair verification drive mode).)</li> <li>• Stop vehicle and access ON BOARD SYSTEM READINESS TESTS to inspect Drive Mode completion status.</li> <li>• Has EVAPORATIVE PURGE SYSTEM been monitored?</li> </ul>	Yes	Go to next step.
		No	Go back to Step 28.
30	<b>VERIFY EVAP SYSTEM REPAIRED</b> <ul style="list-style-type: none"> <li>• Access DIAGNOSTIC MONITORING TEST RESULTS.</li> <li>• Verify TEST ID 10:22:00 value. (See 01-02B-9 Diagnostic Monitoring Test Results Access Procedure.)</li> <li>• Is it below maximum value?</li> </ul>	Yes	Go to Step 32.
		No	Replace PCM, then go to Step 32.
31	<b>INSPECT WHOLE EVAP CONTROL SYSTEM</b> <ul style="list-style-type: none"> <li>• Implement "01-03B ENGINE CONTROL SYSTEM OPERATION INSPECTION [FS], Evaporative System Leak Inspection Using Vacuum Pump, Whole system inspection". (See 01-03B-55 Whole system inspection.)</li> <li>• Does voltage change under to specified readings and hold for <b>minimum of 2 minutes</b>?</li> </ul>	Yes	Go to Step 32.
		No	Replace PCM, then go to Step 32.
32	<b>VERIFY AFTER REPAIR PROCEDURE</b> <ul style="list-style-type: none"> <li>• Perform "After Repair Procedure". (See 01-02B-9 AFTER REPAIR PROCEDURE [FS].)</li> <li>• Is there any DTC present?</li> </ul>	Yes	Go to applicable DTC inspection. (See 01-02B-15 DTC TABLE [FS].)
		No	Troubleshooting completed.

01-02B

# ON-BOARD DIAGNOSTIC [ENGINE CONTROL SYSTEM (FS)]

DTC P0456 [FS]

A3U010201086W10

DTC P0456	Evaporative emission control system leak detected (very small leak)
<b>DETECTION CONDITION</b>	<ul style="list-style-type: none"> <li>PCM measures the fuel tank pressure ftp a and ftp b when monitoring conditions are met. If the difference between ftp a and ftp b exceeds the threshold, PCM determines that EVAP system has a very small leak (0.5 mm {0.02 in} hole equivalent).</li> </ul> <p><b>MONITORING CONDITION</b></p> <ul style="list-style-type: none"> <li>— ECT at engine start 35 °C {95 °F} or below</li> <li>— ECT 70—108 °C {158—226 °F}</li> <li>— Atmospheric pressure: above 69.7 kPa {523 mmHg, 20.5 inHg}</li> <li>— Remaining fuel 35%—85%</li> <li>— IAT -10—60 °C {14—140 °F}</li> <li>— Throttle opening angle closed</li> <li>— 16 minutes or less after engine start</li> </ul> <p><b>Diagnostic support note</b></p> <ul style="list-style-type: none"> <li>This is an intermittent monitor (Evaporative leak monitor).</li> <li>MIL illuminates if PCM detects the above malfunction condition in two consecutive drive cycles.</li> <li>PENDING CODE are stored if PCM detects the above malfunction condition during first drive cycle.</li> <li>DIAGNOSTIC MONITORING TEST RESULTS is available.</li> <li>FREEZE FRAME DATA is available.</li> <li>DTC is stored in the PCM memory.</li> </ul>
<b>POSSIBLE CAUSE</b>	<ul style="list-style-type: none"> <li>Purge solenoid valve malfunction</li> <li>Canister drain cut valve (CDCV) malfunction</li> <li>Charcoal canister malfunction</li> <li>Catch tank malfunction</li> <li>Fuel cap malfunction</li> <li>Fuel tank malfunction</li> <li>Fuel pump unit poor seal</li> <li>EVAP hose damaged or loose</li> <li>EVAP pipe damaged</li> </ul>

**Diagnostic procedure**

STEP	INSPECTION		ACTION
1	<b>VERIFY FREEZE FRAME DATA HAS BEEN RECORDED</b> <ul style="list-style-type: none"> <li>Has FREEZE FRAME PID DATA been recorded?</li> </ul>	Yes	Go to next step.
		No	Record FREEZE FRAME PID DATA on repair order, then go to next step.
2	<b>VERIFY RELATED REPAIR INFORMATION AVAILABILITY</b> <ul style="list-style-type: none"> <li>Check for related Service Bulletins and/or on-line repair information availability.</li> <li>Is any related repair information available?</li> </ul>	Yes	Perform repair or diagnosis according to available repair information. <ul style="list-style-type: none"> <li>If vehicle is not repaired, go to next step.</li> </ul>
		No	Go to next step.
3	<b>VERIFY RELATED PENDING CODE OR STORED DTC</b> <ul style="list-style-type: none"> <li>Turn ignition key to OFF then ON (Engine OFF).</li> <li>Verify related pending code or stored DTC.</li> <li>Is other DTC present?</li> </ul>	Yes	Go to appropriate DTC inspection.
		No	Go to next step.

## ON-BOARD DIAGNOSTIC [ENGINE CONTROL SYSTEM (FS)]

STEP	INSPECTION	ACTION	
4	<b>CLASSIFY INTERMITTENT CONCERN OR CONTINUOUS CONCERN</b> <ul style="list-style-type: none"> <li>• Perform evaporative system leak inspection. (See 01–03B–54 Evaporative System Leak Inspection Using Leak Tester.)</li> <li>• Is test result failed (red light turns on)?</li> </ul>	Yes	Go to next step.
		No	Intermittent concern existing. Inspect purge solenoid valve and CDCV circuit for intermittent concern. (See 01–03B–4 INTERMITTENT CONCERN TROUBLESHOOTING [FS].)
5	<b>LOCATE LEAK POINT</b> <ul style="list-style-type: none"> <li>• Check leakage for the following using Ultrasonic leak detector.                             <ul style="list-style-type: none"> <li>— Charcoal canister</li> <li>— Catch tank</li> <li>— Fuel cap</li> <li>— EVAP hoses and pipes</li> <li>— Fuel tank</li> </ul> </li> <li>• Is leakage found?</li> </ul>	Yes	Repair leakage or replace part, then go to Step 10.
		No	Go to next step.
6	<b>INSPECT PURGE SOLENOID VALVE</b> <ul style="list-style-type: none"> <li>• Disconnect purge solenoid valve tube that is connected to intake manifold.</li> <li>• Connect vacuum pump to purge solenoid valve.</li> <li>• Apply vacuum and wait for <b>5 seconds</b>.</li> <li>• Is vacuum maintained?</li> </ul>	Yes	Go to next step.
		No	Replace purge solenoid valve, then go to Step 10.
7	<b>INSPECT CDCV</b> <ul style="list-style-type: none"> <li>• Connect all disconnected connectors and hoses.</li> <li>• Place clamp on CDCV hose between CDCV and air filter.</li> <li>• Perform evaporative system leak inspection. (See 01–03B–54 Evaporative System Leak Inspection Using Leak Tester.)</li> <li>• Is test result failed (red light turns on)?</li> </ul>	Yes	Go to Step 10.
		No	Go to next step.
8	<b>CONFIRM CDCV LEAKAGE</b> <ul style="list-style-type: none"> <li>• Remove clamp.</li> <li>• Perform evaporative system leak inspection. (See 01–03B–54 Evaporative System Leak Inspection Using Leak Tester.)</li> <li>• Is test result failed (red light turns on)?</li> </ul>	Yes	Replace CDCV, then go to Step 11.
		No	Go to Step 11.
9	<b>INSPECT FUEL PUMP UNIT INSTALLATION</b> <ul style="list-style-type: none"> <li>• Remove fuel tank.</li> <li>• Visually inspect for damage, insufficient sealing or poorly installed fuel pump unit.</li> <li>• Is it okay?</li> </ul>	Yes	Go to next step.
		No	Repair or replace fuel tank or sealing, then go to next step.
10	<b>PERFORM LEAK INSPECTION</b> <ul style="list-style-type: none"> <li>• Connect all disconnected connectors and hoses.</li> <li>• Perform evaporative system leak inspection. (See 01–03B–54 Evaporative System Leak Inspection Using Leak Tester.)</li> <li>• Is test result failed (red light turns on)?</li> </ul>	Yes	Leakage still exists. Locate leak point and repair. Then go to next step.
		No	Go to next step.
11	<b>VERIFY MONITORING CONDITION FOR EVAPORATIVE SYSTEM TEST OR DRIVE MODE 5</b> <ul style="list-style-type: none"> <li>• Turn ignition key to ON (Engine OFF).</li> <li>• Access ECT and FTL V PIDs using NGS tester.                             <ul style="list-style-type: none"> <li>— ECT: <b>35 °C {95 °F} or below</b></li> <li>— FTL V: <b>1.3 V—3.75 V (35—85% fuel tank level equivalent)</b></li> <li>— IAT: <b>-10—60 °C {14—140 °F}</b></li> </ul> </li> <li><b>Note</b> <ul style="list-style-type: none"> <li>• All PIDs must be within specification to start monitor.</li> </ul> </li> <li>• Is there any PID that is out of specification?</li> </ul>	Yes	Cool down engine with fan or adjust fuel level, then go to next step.
		No	Go to next step.

01–02B

## ON-BOARD DIAGNOSTIC [ENGINE CONTROL SYSTEM (FS)]

STEP	INSPECTION	ACTION
12	<b>VERIFY TROUBLESHOOTING OF DTC P0456 COMPLETED</b> <ul style="list-style-type: none"> <li>Clear DTC using NGS tester generic OBD-II function.</li> <li>Run engine at <b>3.500 rpm</b> for <b>3 minutes</b>, then run at idle for <b>6 minutes</b>.</li> <li>Access DIAGNOSTIC MONITORING TEST RESULTS.</li> <li>Verify TEST ID 10:23:00 value.</li> <li>Does it indicate 0 or 65535.</li> </ul>	Yes Monitoring was not implemented. Repeat Step 10.
		No Go to next step.
13	<b>VERIFY P0456 MONITOR RESULT</b> <ul style="list-style-type: none"> <li>Is below MAX value?</li> </ul>	Yes Go to next step.
		No Replace PCM, then go to next step.
14	<b>VERIFY AFTER REPAIR PROCEDURE</b> <ul style="list-style-type: none"> <li>Perform "After Repair Procedure". (See 01-02B-9 AFTER REPAIR PROCEDURE [FS].)</li> <li>Is there any DTC present?</li> </ul>	Yes Go to appropriate DTC inspection. (See 01-02B-15 DTC TABLE [FS].)
		No Troubleshooting completed.

### DTC P0461 [FS]

A3U010201086W11

DTC P0461	Fuel gauge sender unit circuit range/performance
<b>DETECTION CONDITION</b>	<ul style="list-style-type: none"> <li>PCM monitors fuel gauge sender unit input voltage difference before and after PCM-calculated fuel consumption has reached <b>19.3 liters (20.4 US qt., 17.0 Imp qt.)</b>. If fuel gauge sender unit operation reflects <b>5% less</b> than PCM-calculated fuel consumption, PCM determines that fuel gauge sender unit range/performance is in error.</li> </ul> <p><b>Diagnostic support note</b></p> <ul style="list-style-type: none"> <li>This is a continuous monitor (CCM).</li> <li>MIL illuminates if PCM detects the above malfunction condition in two consecutive drive cycles.</li> <li>PENDING CODE is available if PCM detects the above malfunction condition during first drive cycle.</li> <li>FREEZE FRAME DATA is available.</li> <li>DTC is stored in PCM memory.</li> </ul>
<b>POSSIBLE CAUSE</b>	<ul style="list-style-type: none"> <li>Fuel gauge sender unit malfunction or substandard performance</li> </ul>

### Diagnostic procedure

STEP	INSPECTION	ACTION
1	<b>VERIFY FREEZE FRAME DATA HAS BEEN RECORDED</b> <ul style="list-style-type: none"> <li>Has FREEZE FRAME DATA been recorded?</li> </ul>	Yes Go to next step.
		No Record FREEZE FRAME DATA on repair order, then go to next step.
2	<b>VERIFY RELATED REPAIR INFORMATION AVAILABILITY</b> <ul style="list-style-type: none"> <li>Check for related Service Bulletins availability.</li> <li>Is any related repair information available?</li> </ul>	Yes Perform repair or diagnosis according to available repair information. <ul style="list-style-type: none"> <li>If vehicle is not repaired, go to next step.</li> </ul>
		No Go to next step.
3	<b>INSPECT FUEL GAUGE SENDER UNIT</b> <ul style="list-style-type: none"> <li>Turn ignition key to OFF.</li> <li>Inspect fuel gauge sender unit. (See 09-22-13 FUEL GAUGE SENDER UNIT INSPECTION.)</li> <li>Is fuel gauge sender unit okay?</li> </ul>	Yes Replace PCM, then go to next step.
		No Repair or replace fuel gauge sender unit, then go to next step.
4	<b>VERIFY AFTER REPAIR PROCEDURE</b> <ul style="list-style-type: none"> <li>Perform "After Repair Procedure". (See 01-02B-9 AFTER REPAIR PROCEDURE [FS].)</li> <li>Is there any DTC present?</li> </ul>	Yes Go to applicable DTC inspection. (See 01-02B-15 DTC TABLE [FS].)
		No Troubleshooting completed.



# ON-BOARD DIAGNOSTIC [ENGINE CONTROL SYSTEM (FS)]

DTC P0462 [FS]

A3U010201086W12

01-02B

<b>DTC P0462</b>	<b>Fuel gauge sender unit circuit low input</b>
<b>DETECTION CONDITION</b>	<ul style="list-style-type: none"> <li>PCM monitors the voltage of fuel gauge sender unit. If PCM detects PCM terminal 63 voltage <b>below 0.08 V for 5 seconds</b>, PCM determines that fuel gauge sender unit circuit has a malfunction.</li> </ul> <p><b>Diagnostic support note</b></p> <ul style="list-style-type: none"> <li>This is a continuous monitor (CCM).</li> <li>MIL illuminates if PCM detects the above malfunction condition in two consecutive drive cycles.</li> <li>PENDING CODE is available if PCM detects the above malfunction condition during first drive cycle.</li> <li>FREEZE FRAME DATA is available.</li> <li>DTC is stored in PCM memory.</li> </ul>
<b>POSSIBLE CAUSE</b>	<ul style="list-style-type: none"> <li>Fuel gauge sender unit malfunction</li> <li>Short to ground circuit between fuel gauge sender unit terminal A and PCM terminal 63</li> <li>Short circuit between fuel level signal circuit and fuel gauge sender unit ground circuit</li> <li>PCM malfunction</li> <li>Bent terminals of fuel gauge sender unit</li> </ul>

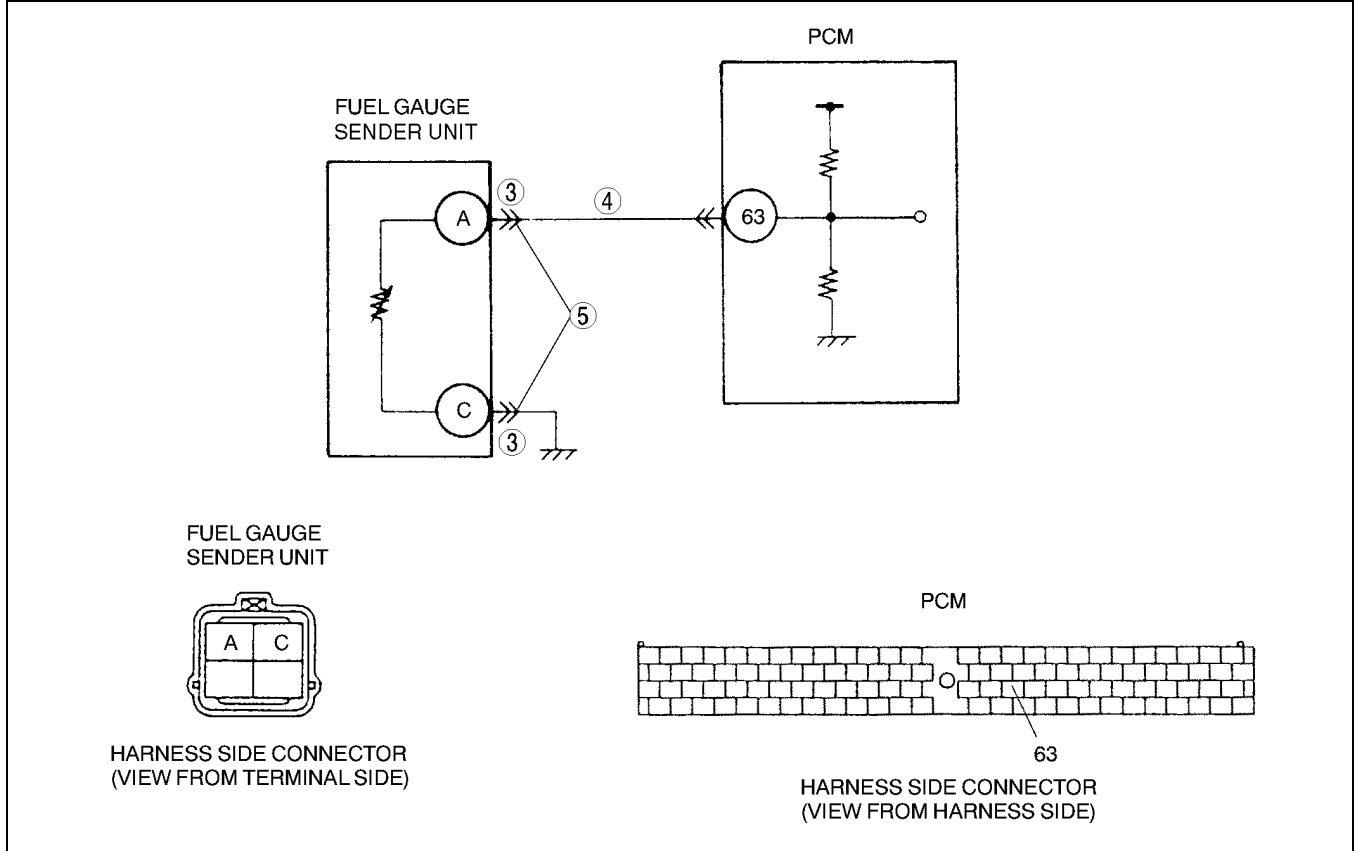

**Diagnostic procedure**

STEP	INSPECTION		ACTION
1	<b>VERIFY FREEZE FRAME DATA HAS BEEN RECORDED</b> <ul style="list-style-type: none"> <li>Has FREEZE FRAME DATA been recorded?</li> </ul>	Yes	Go to next step.
		No	Record FREEZE FRAME DATA on repair order, then go to next step.
2	<b>VERIFY RELATED REPAIR INFORMATION AVAILABILITY</b> <ul style="list-style-type: none"> <li>Check for related Service Bulletins availability.</li> <li>Is any related repair information available?</li> </ul>	Yes	Perform repair or diagnosis according to available repair information. <ul style="list-style-type: none"> <li>If vehicle is not repaired, go to next step.</li> </ul>
		No	Go to next step.
3	<b>INSPECT TERMINAL FOR BENT</b> <ul style="list-style-type: none"> <li>Turn ignition key to OFF.</li> <li>Disconnect fuel gauge sender unit connector.</li> <li>Check for bent terminal.</li> <li>Is there malfunction?</li> </ul>	Yes	Repair suspected terminal, then go to Step 6.
		No	Go to next step.

## ON-BOARD DIAGNOSTIC [ENGINE CONTROL SYSTEM (FS)]

STEP	INSPECTION	ACTION	
4	<b>INSPECT FUEL LEVEL SIGNAL CIRCUIT FOR SHORT TO GROUND</b> <ul style="list-style-type: none"> <li>• Turn ignition key to OFF.</li> <li>• Disconnect PCM connector.</li> <li>• Check for continuity between fuel gauge sender unit terminal A (harness-side) and body GND.</li> <li>• Is there continuity?</li> </ul>	Yes	Repair or replace suspected harness, then go to Step 6.
		No	Go to next step.
5	<b>INSPECT FUEL GAUGE SENDER UNIT CIRCUITS FOR SHORTS</b> <ul style="list-style-type: none"> <li>• Check for continuity between fuel gauge sender unit terminals A and C (harness-side).</li> <li>• Is there continuity?</li> </ul>	Yes	Repair or replace suspected harness, then go to Step 6.
		No	Go to next step.
6	<b>VERIFY TROUBLESHOOTING OF DTC P0462 COMPLETED</b> <ul style="list-style-type: none"> <li>• Make sure to reconnect all disconnected connectors.</li> <li>• Turn ignition key to ON (Engine OFF).</li> <li>• Clear DTC from memory using WDS or equivalent.</li> <li>• Start engine.</li> <li>• Is pending code of same DTC present?</li> </ul>	Yes	Replace PCM, then go to next step.
		No	Go to next step.
7	<b>VERIFY AFTER REPAIR PROCEDURE</b> <ul style="list-style-type: none"> <li>• Perform "After Repair Procedure". (See 01-02B-9 AFTER REPAIR PROCEDURE [FS].)</li> <li>• Is there any DTC present?</li> </ul>	Yes	Go to applicable DTC inspection. (See 01-02B-15 DTC TABLE [FS].)
		No	Troubleshooting completed.

# ON-BOARD DIAGNOSTIC [ENGINE CONTROL SYSTEM (FS)]

DTC P0463 [FS]

A3U010201086W13

01-02B

<b>DTC P0463</b>	<b>Fuel gauge sender unit circuit high input</b>
<b>DETECTION CONDITION</b>	<ul style="list-style-type: none"> <li>PCM monitors the voltage of fuel gauge sender unit. If PCM detects PCM terminal 63 voltage <b>above 4.92 V for 5 seconds</b>, PCM determines that fuel gauge sender unit circuit has a malfunction.</li> </ul> <p><b>Diagnostic support note</b></p> <ul style="list-style-type: none"> <li>This is a continuous monitor (CCM).</li> <li>MIL illuminates if PCM detects the above malfunction condition in two consecutive drive cycles.</li> <li>PENDING CODE is available if PCM detects the above malfunction condition during first drive cycle.</li> <li>FREEZE FRAME DATA is available.</li> <li>DTC is stored in PCM memory.</li> </ul>
<b>POSSIBLE CAUSE</b>	<ul style="list-style-type: none"> <li>Fuel gauge sender unit malfunction</li> <li>Open circuit between fuel gauge sender unit terminal A and PCM terminal 63.</li> <li>Open circuit between fuel gauge sender unit terminal C and body ground.</li> <li>Poor connection of fuel gauge sender unit and/or PCM connector</li> <li>PCM malfunction</li> </ul>

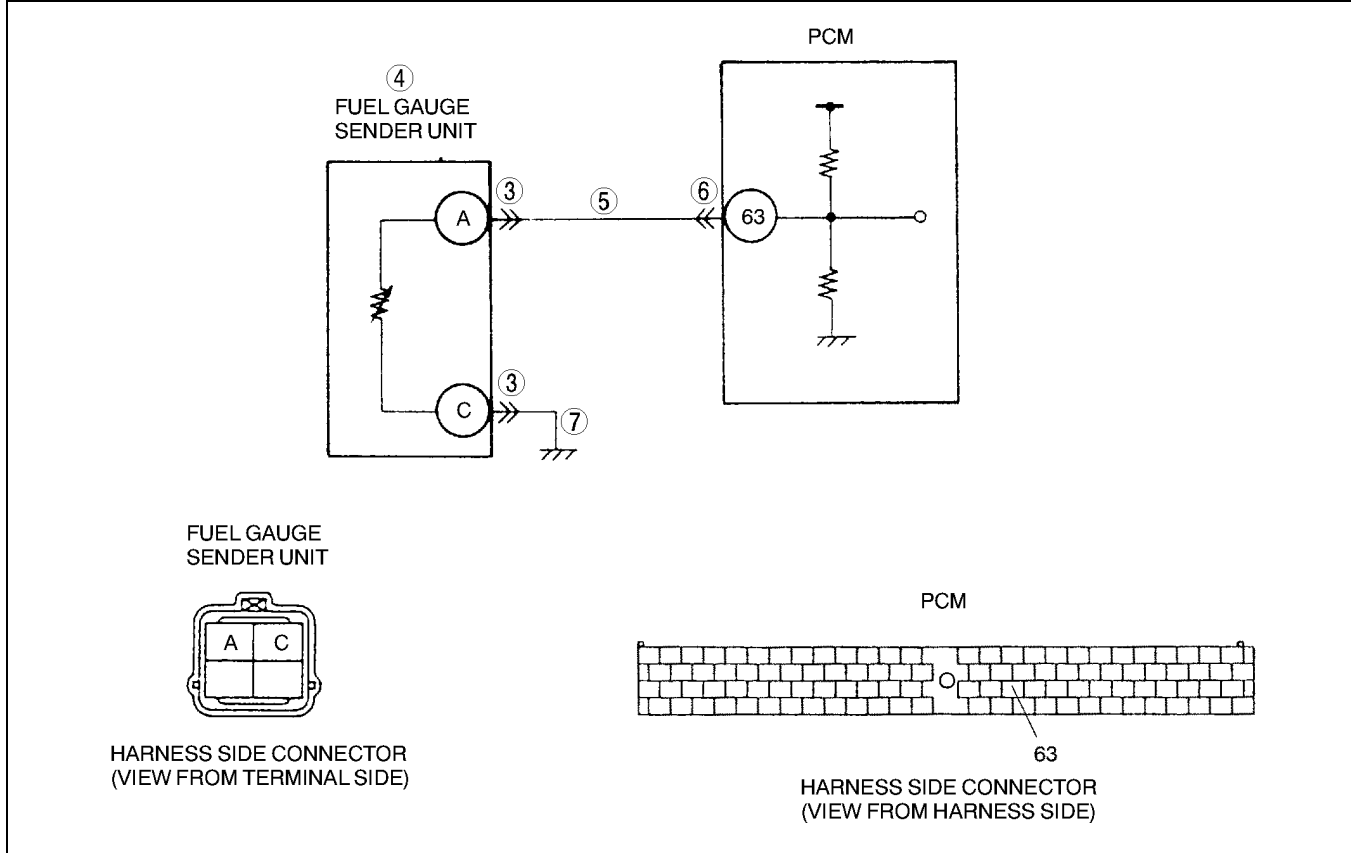

**Diagnostic procedure**

STEP	INSPECTION		ACTION
1	<b>VERIFY FREEZE FRAME DATA HAS BEEN RECORDED</b> <ul style="list-style-type: none"> <li>Has FREEZE FRAME DATA been recorded?</li> </ul>	Yes	Go to next step.
		No	Record FREEZE FRAME DATA on repair order, then go to next step.
2	<b>VERIFY RELATED REPAIR INFORMATION AVAILABILITY</b> <ul style="list-style-type: none"> <li>Check for related Service Bulletins availability.</li> <li>Is any related repair information available?</li> </ul>	Yes	Perform repair or diagnosis according to available repair information. <ul style="list-style-type: none"> <li>If vehicle is not repaired, go to next step.</li> </ul>
		No	Go to next step.
3	<b>INSPECT FUEL GAUGE SENDER UNIT CONNECTOR FOR POOR CONNECTION</b> <ul style="list-style-type: none"> <li>Turn ignition key to OFF.</li> <li>Disconnect fuel gauge sender unit connector.</li> <li>Check for poor connection (damaged/pulled-out terminals, corrosion, etc.).</li> <li>Is there malfunction?</li> </ul>	Yes	Repair suspected terminal, then go to Step 8.
		No	Go to next step.

## ON-BOARD DIAGNOSTIC [ENGINE CONTROL SYSTEM (FS)]

STEP	INSPECTION	ACTION	
4	<b>INSPECT FUEL GAUGE SENDER UNIT</b> <ul style="list-style-type: none"> <li>Inspect fuel gauge sender unit. (See 09–22–13 FUEL GAUGE SENDER UNIT INSPECTION.)</li> <li>Is fuel gauge sender unit okay?</li> </ul>	Yes	Connect fuel gauge sender unit connector, then go to next step.
		No	Replace fuel gauge sender unit, then go to Step 8.
5	<b>INSPECT FTL SIGNAL CIRCUIT FOR OPEN CIRCUIT</b> <ul style="list-style-type: none"> <li>Turn ignition key to ON (Engine OFF).</li> <li>Measure voltage between fuel gauge sender unit terminal A (harness-side) and body ground.</li> <li>Is voltage <b>above 4.5—5.5 V</b>?</li> </ul>	Yes	Go to Step 8.
		No	Go to next step.
6	<b>INSPECT PCM CONNECTOR FOR POOR CONNECTION</b> <ul style="list-style-type: none"> <li>Turn ignition key to OFF.</li> <li>Disconnect PCM connector.</li> <li>Check for poor connection (damaged/pulled-out terminals, corrosion, etc.).</li> <li>Is there malfunction?</li> </ul>	Yes	Repair suspected terminal, then go to Step 8.
		No	Repair or replace open circuit between fuel gauge sender unit terminal A (harness-side) and PCM terminal 63 (harness-side), then go to Step 8.
7	<b>INSPECT FUEL GAUGE SENDER UNIT GROUND CIRCUIT FOR OPEN CIRCUIT</b> <ul style="list-style-type: none"> <li>Turn ignition key to OFF.</li> <li>Check for continuity between fuel gauge sender unit terminal C (harness-side) and body ground.</li> <li>Is there continuity?</li> </ul>	Yes	Go to next step.
		No	Repair or replace harness for open, then go to next step.
8	<b>VERIFY TROUBLESHOOTING OF DTC P0463 COMPLETED</b> <ul style="list-style-type: none"> <li>Make sure to reconnect all disconnected connectors.</li> <li>Turn ignition key to ON (Engine OFF).</li> <li>Clear DTC from memory using WDS or equivalent.</li> <li>Start engine.</li> <li>Is pending code of same DTC present?</li> </ul>	Yes	Replace PCM, then go to next step.
		No	No concern is detected. Go to next step.
9	<b>VERIFY AFTER REPAIR PROCEDURE</b> <ul style="list-style-type: none"> <li>Perform “After Repair Procedure”. (See 01–02B–9 AFTER REPAIR PROCEDURE [FS].)</li> <li>Is there any DTC present?</li> </ul>	Yes	Go to applicable DTC inspection. (See 01–02B–15 DTC TABLE [FS].)
		No	Troubleshooting completed.

### DTC P0464 [FS]

A3U010201086W14

DTC P0464	Fuel gauge sender unit circuit performance (slosh check)
<b>DETECTION CONDITION</b>	<ul style="list-style-type: none"> <li>PCM monitors fuel gauge sender unit input voltage at PCM terminal 63 while engine is running. If differences are high for <b>14 seconds</b> while vehicle is stopped, PCM determines that FTL signal is incorrect.</li> </ul> <b>Diagnostic support note</b> <ul style="list-style-type: none"> <li>This is a continuous monitor (CCM).</li> <li>MIL illuminates if PCM detects the above malfunction condition in two consecutive drive cycles.</li> <li>PENDING CODE is available if PCM detects the above malfunction condition during first drive cycle.</li> <li>FREEZE FRAME DATA is available.</li> <li>DTC is stored in PCM memory.</li> </ul>
<b>POSSIBLE CAUSE</b>	<ul style="list-style-type: none"> <li>Fuel gauge sender unit malfunction or substandard performance</li> </ul>

### Diagnostic procedure

STEP	INSPECTION	ACTION	
1	<b>VERIFY FREEZE FRAME DATA HAS BEEN RECORDED</b> <ul style="list-style-type: none"> <li>Has FREEZE FRAME DATA been recorded?</li> </ul>	Yes	Go to next step.
		No	Record FREEZE FRAME DATA on repair order, then go to next step.
2	<b>VERIFY RELATED REPAIR INFORMATION AVAILABILITY</b> <ul style="list-style-type: none"> <li>Check for related Service Bulletins availability.</li> <li>Is any related repair information available?</li> </ul>	Yes	Perform repair or diagnosis according to available repair information. <ul style="list-style-type: none"> <li>If vehicle is not repaired, Go to next step.</li> </ul>
		No	Go to next step.

# ON-BOARD DIAGNOSTIC [ENGINE CONTROL SYSTEM (FS)]

STEP	INSPECTION		ACTION
3	<b>INSPECT FUEL GAUGE SENDER UNIT</b> <ul style="list-style-type: none"> <li>Turn ignition key to OFF.</li> <li>Inspect fuel gauge sender unit. (See 09-22-13 FUEL GAUGE SENDER UNIT INSPECTION.)</li> <li>Is fuel gauge sender unit okay?</li> </ul>	Yes	Replace PCM, then go to next step.
		No	Repair or replace fuel gauge sender unit, then go to next step.
4	<b>VERIFY AFTER REPAIR PROCEDURE</b> <ul style="list-style-type: none"> <li>Perform "After Repair Procedure". (See 01-02B-9 AFTER REPAIR PROCEDURE [FS].)</li> <li>Is there any DTC present?</li> </ul>	Yes	Go to applicable DTC inspection. (See 01-02B-15 DTC TABLE [FS].)
		No	Troubleshooting completed.

01-02B

## DTC P0480 [FS]

A3U010201086W15

DTC P0480	Cooling fan relay circuit
<b>DETECTION CONDITION</b>	<ul style="list-style-type: none"> <li>PCM monitors control signal to cooling fan relay coil control circuit. If signal at PCM terminal 47 remains low or high, PCM determines that cooling fan relay circuit has malfunction.</li> </ul> <p><b>Diagnostic support note</b></p> <ul style="list-style-type: none"> <li>This is a continuous monitor (CCM)</li> <li>PCM detects the above malfunction condition in two consecutive drive cycles.</li> <li>PENDING CODE is available if PCM detects the above malfunction condition during first drive cycles.</li> <li>FREEZE FRAME DATA is available.</li> <li>DTC is stored in PCM memory.</li> </ul>
<b>POSSIBLE CAUSE</b>	<ul style="list-style-type: none"> <li>Cooling fan relay malfunction</li> <li>Connector or terminal malfunction</li> <li>Short to GND circuit in wiring between cooling fan relay terminal B and PCM terminal 47</li> <li>Open circuit in wiring between cooling fan relay terminal B and PCM terminal 47</li> <li>Open circuit in wiring between main relay terminal D and cooling fan relay terminal C</li> <li>PCM malfunction</li> </ul>

### Diagnostic procedure

STEP	INSPECTION		ACTION
1	<b>VERIFY FREEZE FRAME DATA HAS BEEN RECORDED</b> <ul style="list-style-type: none"> <li>Has FREEZE FRAME DATA been recorded?</li> </ul>	Yes	Go to next step.
		No	Record FREEZE FRAME DATA on repair order, then go to next step.

## ON-BOARD DIAGNOSTIC [ENGINE CONTROL SYSTEM (FS)]

STEP	INSPECTION	ACTION	
2	<b>VERIFY RELATED REPAIR INFORMATION AVAILABILITY</b> <ul style="list-style-type: none"> <li>• Check for related Service Bulletins and/or on-line repair information availability.</li> <li>• Is any Service Information available?</li> </ul>	Yes	Perform repair or diagnosis according to available repair Information. <ul style="list-style-type: none"> <li>• If vehicle is not repaired, go to next step.</li> </ul>
		No	Go to next step.
3	<b>CLASSIFY INTERMITTENT CONCERN OR CONTINUOUS CONCERN</b> <ul style="list-style-type: none"> <li>• Start engine.</li> <li>• Operate A/C to operate cooling fan relay.</li> <li>• Is same of DTC present?</li> </ul>	Yes	Go to next step.
		No	Refer to intermittent concern. (See 01-03B-4 INTERMITTENT CONCERN TROUBLESHOOTING [FS].)
4	<b>INSPECT COOLING FAN RELAY FOR POOR CONNECTION</b> <ul style="list-style-type: none"> <li>• Turn ignition key to OFF.</li> <li>• Disconnect cooling fan relay connector.</li> <li>• Check for poor connection (damaged, pulled-out terminals, corrosion, etc.).</li> <li>• Is there malfunction?</li> </ul>	Yes	Repair or replace terminals, go to Step 10.
		No	Go to next step.
5	<b>INSPECT POWER CIRCUIT FOR OPEN CIRCUIT</b> <ul style="list-style-type: none"> <li>• Turn ignition key to ON (Engine OFF).</li> <li>• Measure voltage between cooling fan relay terminal C (harness-side) and body GND.</li> <li>• Is voltage <b>B+</b>?</li> </ul>	Yes	Go to next step.
		No	Repair or replace harness, go to Step 10.
6	<b>INSPECT COOLING FAN RELAY</b> <ul style="list-style-type: none"> <li>• Inspect cooling fan relay.</li> <li>• Is cooling fan relay okay?</li> </ul>	Yes	Go to next step.
		No	Replace cooling fan relay, go to Step 10.
7	<b>INSPECT PCM CONNECTOR FOR POOR CONNECTION</b> <ul style="list-style-type: none"> <li>• Disconnect PCM connector.</li> <li>• Check for poor connection at terminal 47 (damaged, pulled-out terminals, corrosion, etc.).</li> <li>• Is there malfunction?</li> </ul>	Yes	Repair terminal, go to Step 10.
		No	Go to next step.
8	<b>INSPECT CONTROL CIRCUIT FOR SHORT</b> <ul style="list-style-type: none"> <li>• Check for continuity between cooling fan relay terminal B (harness-side) and body GND.</li> <li>• Is there continuity?</li> </ul>	Yes	Repair or replace harness for short to GND, go to Step 10.
		No	Turn ignition key to ON. Measure voltage between cooling fan relay terminal B and body GND. <ul style="list-style-type: none"> <li>• If voltage is <b>B+</b>, repair or replace harness for short to power, go to next step.</li> <li>• If voltage is <b>approx. 0 V</b>, go to next step.</li> </ul>
9	<b>INSPECT CONTROL CIRCUIT FOR OPEN CIRCUIT</b> <ul style="list-style-type: none"> <li>• Turn ignition key to OFF.</li> <li>• Check for continuity between cooling fan relay terminal B (harness-side) and PCM terminal 47 (harness-side).</li> <li>• Is there continuity?</li> </ul>	Yes	Go to next step.
		No	Repair or replace harness for open, go to next step.
10	<b>VERIFY TROUBLESHOOTING OF DTC P0480 COMPLETED</b> <ul style="list-style-type: none"> <li>• Make sure to reconnect all disconnected connectors.</li> <li>• Clear DTC from PCM memory using WDS or equivalent.</li> <li>• Start engine.</li> <li>• Operate A/C for operate cooling fan relay.</li> <li>• Is PENDING CODE of same DTC present?</li> </ul>	Yes	Replace PCM, go to next step.
		No	Go to next step.
11	<b>VERIFY AFTER REPAIR PROCEDURE</b> <ul style="list-style-type: none"> <li>• Perform "After Repair Procedure". (See 01-02B-9 AFTER REPAIR PROCEDURE [FS].)</li> <li>• Is there any DTC present?</li> </ul>	Yes	Go to applicable DTC inspection. (See 01-02B-15 DTC TABLE [FS].)
		No	Troubleshooting completed.

# ON-BOARD DIAGNOSTIC [ENGINE CONTROL SYSTEM (FS)]

DTC P0500 [FS]

A3U010201087W01

01-02B

<b>DTC P0500</b>	<b>Vehicle speed sensor (VSS) circuit malfunction (MTX)</b>
<b>DETECTION CONDITION</b>	<ul style="list-style-type: none"> <li>• Vehicle speed signal does not input after following conditions are met:                             <ul style="list-style-type: none"> <li>— Gear is in position other than neutral.</li> <li>— Load is above <b>40%</b>.</li> <li>— Engine speed is <b>2,000 rpm or above</b>.</li> </ul> </li> </ul> <p><b>Diagnostic support note:</b></p> <ul style="list-style-type: none"> <li>• This is a continuous monitor (CCM).</li> <li>• MIL illuminates if PCM detects the above malfunction conditions in two consecutive drive cycles.</li> <li>• PENDING CODE is available if PCM detects the above malfunction condition during first drive cycle.</li> <li>• FREEZE FRAME DATA is available.</li> <li>• DTC is stored in PCM memory.</li> </ul>
<b>POSSIBLE CAUSE</b>	<ul style="list-style-type: none"> <li>• PCM malfunction</li> <li>• Instrument cluster malfunction</li> <li>• ABS HU/CM malfunction</li> <li>• Open circuit between PCM terminal 58 and instrument cluster terminal 30</li> <li>• Short to ground between PCM terminal 58 and instrument cluster terminal 30</li> <li>• Vehicle speedometer sensor malfunction</li> <li>• Open circuit between vehicle speedometer sensor terminal A and instrument cluster terminal 3G</li> <li>• Short to ground between vehicle speedometer sensor terminal A and instrument cluster terminal 3G</li> <li>• Open circuit between vehicle speedometer sensor terminal B and instrument cluster terminal 3I</li> <li>• Short to ground between vehicle speedometer sensor terminal B and instrument cluster terminal 3I</li> </ul>

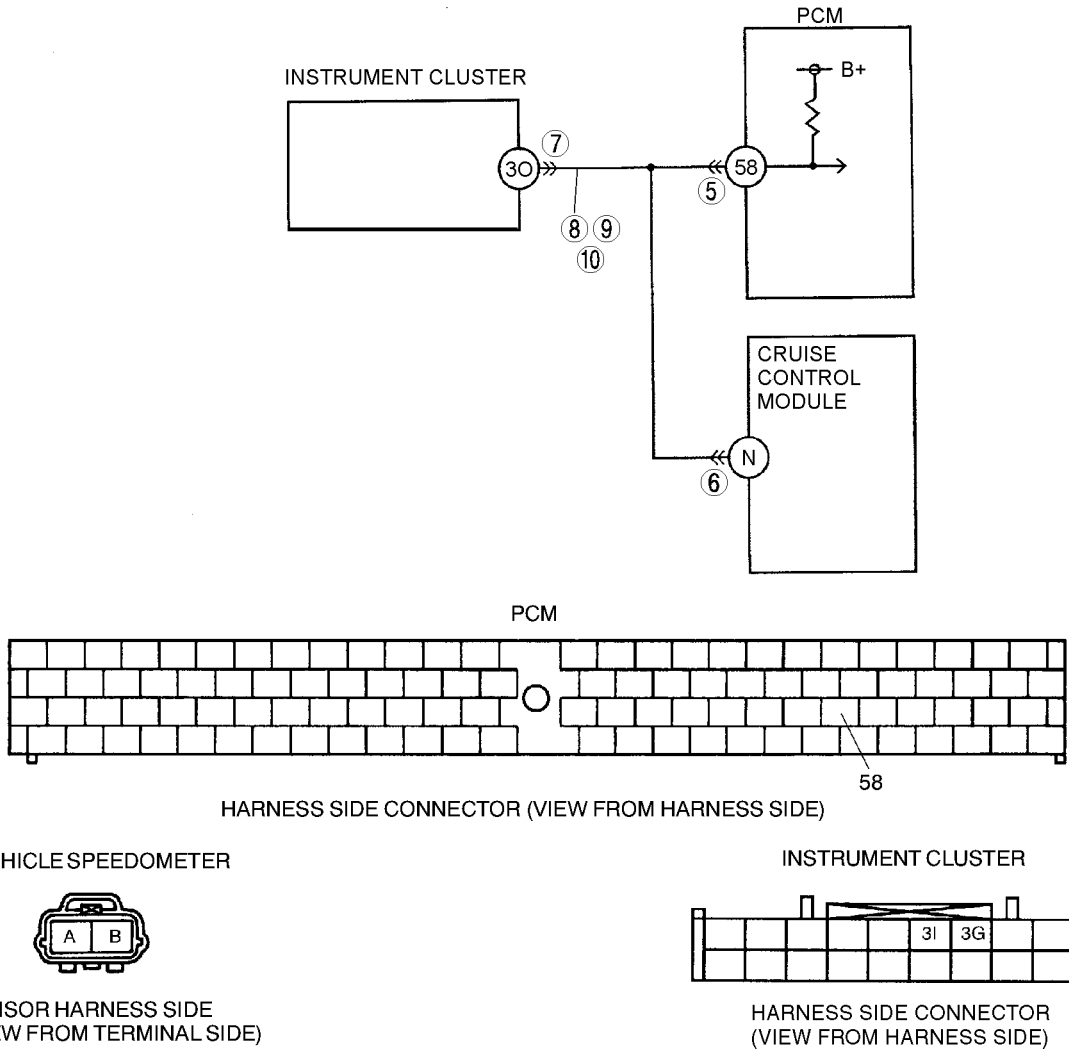

## ON-BOARD DIAGNOSTIC [ENGINE CONTROL SYSTEM (FS)]

### Diagnostic procedure

STEP	INSPECTION	ACTION	
1	<b>VERIFY FREEZE FRAME DATA HAS BEEN RECORDED</b> <ul style="list-style-type: none"> <li>• Has FREEZE FRAME PID DATA been recorded?</li> </ul>	Yes	Go to next step.
		No	Record FREEZE FRAME PID DATA on repair order, then go to next step.
2	<b>VERIFY RELATED REPAIR INFORMATION AVAILABILITY</b> <ul style="list-style-type: none"> <li>• Check for related Service Bulletins availability.</li> <li>• Is any related repair information available?</li> </ul>	Yes	Perform repair or diagnosis according to available repair information. <ul style="list-style-type: none"> <li>• If vehicle is not repaired, go to next step.</li> </ul>
		No	Go to next step.
3	<b>VERIFY CURRENT INPUT SIGNAL STATUS-IS CONCERN INTERMITTENT OR CONSTANT</b> <ul style="list-style-type: none"> <li>• Connect WDS or equivalent to DLC-2.</li> <li>• Start engine.</li> <li>• Access VS PID using WDS or equivalent.                             <ul style="list-style-type: none"> <li>— Vehicle speed <b>20 km/h {12.4 mph}: 20km/h {12.4 mph}</b></li> <li>— Vehicle speed <b>40 km/h {24.8 mph}: 40km/h {24.8 mph}</b></li> </ul> </li> <li>• Are PID readings within specification?</li> </ul>	Yes	Go to intermittent concern troubleshooting procedure. (See 01-03B-4 INTERMITTENT CONCERN TROUBLESHOOTING [FS].)
		No	Go to next step.
4	<b>CHECK INPUT/OUTPUT CHECK MODE</b> <ul style="list-style-type: none"> <li>• Turn ignition key to ON (engine OFF).</li> <li>• Is instrument cluster DTCs 10 or 12 detected? (See 09-22-5 INSTRUMENT CLUSTER INPUT/OUTPUT CHECK MODE.)</li> </ul>	Yes	DTC 10 and/or 12 displayed: Inspect instrument cluster. (See 09-22-5 INSTRUMENT CLUSTER INPUT/OUTPUT CHECK MODE.)
		No	Go to next step.
5	<b>INSPECT PCM CONNECTOR FOR POOR CONNECTION</b> <ul style="list-style-type: none"> <li>• Turn ignition key to OFF.</li> <li>• Disconnect PCM connector.</li> <li>• Check for poor connection (damaged/pulled-out terminals, corrosion, etc.).</li> <li>• Are terminals okay?</li> </ul>	Yes	Go to next step.
		No	Repair or replace pin or connector, then go to Step 11.
6	<b>INSPECT CRUISE CONTROL MODULE CONNECTOR</b> <ul style="list-style-type: none"> <li>• Disconnect cruise control module connector.</li> <li>• Inspect for bent terminals.</li> <li>• Are terminals okay?</li> </ul>	Yes	Go to next step.
		No	Repair terminals, then go to Step 11.
7	<b>INSPECT INSTRUMENT CLUSTER CONNECTOR FOR POOR CONNECTION</b> <ul style="list-style-type: none"> <li>• Turn ignition key to OFF.</li> <li>• Disconnect instrument cluster connector.</li> <li>• Check for poor connections (damaged/pulled-out terminals, corrosion, etc.).</li> <li>• Are terminals okay?</li> </ul>	Yes	Go to next step.
		No	Repair or replace terminals, then go to Step 11.
8	<b>INSPECT VOLTAGE</b> <ul style="list-style-type: none"> <li>• Connect PCM connector.</li> <li>• Turn ignition key to ON (engine OFF).</li> <li>• Measure voltage at instrument cluster terminal 30 (harness-side).</li> <li>• Is there <b>5 V</b> at instrument cluster terminal 30 (harness-side)?</li> </ul>	Yes	Replace instrument cluster, then go to Step 11. (See 09-22-3 INSTRUMENT CLUSTER REMOVAL/INSTALLATION.)
		No	Go to next step.
9	<b>INSPECT INSTRUMENT CLUSTER CIRCUIT FOR OPEN CIRCUIT</b> <ul style="list-style-type: none"> <li>• Turn ignition key to OFF.</li> <li>• Connect breakout box with PCM connector disconnected.</li> <li>• Turn ignition key to ON (engine OFF).</li> <li>• Check for continuity between instrument cluster terminal 30 (harness-side) and breakout box terminal 58.</li> <li>• Is there continuity?</li> </ul>	Yes	Go to next step.
		No	Repair or replace harness, then go to Step 11.
10	<b>INSPECT INSTRUMENT CLUSTER CIRCUIT FOR SHORT TO GROUND</b> <ul style="list-style-type: none"> <li>• Check for continuity between instrument cluster terminal 30 (harness-side) and body ground.</li> <li>• Is there continuity?</li> </ul>	Yes	Repair or replace harness, then go to next step.
		No	Replace instrument cluster, then go to next step.



# ON-BOARD DIAGNOSTIC [ENGINE CONTROL SYSTEM (FS)]

01-02B

STEP	INSPECTION		ACTION
11	<b>VERIFY TROUBLESHOOTING OF DTC P0500 COMPLETED</b> <ul style="list-style-type: none"> <li>Make sure to reconnect all disconnected connectors.</li> <li>Clear DTC from memory using WDS or equivalent.</li> <li>Warm up engine.</li> <li>Drive vehicle under following conditions for 16 seconds.                             <ul style="list-style-type: none"> <li>— Engine speed: <b>1,800 rpm or above</b></li> <li>— Gear: not in neutral.</li> <li>— Load: <b>40% or above</b></li> </ul> </li> <li>Is PENDING CODE of same DTC present?</li> </ul>	Yes	Replace PCM, then go to next step. (See 01-40B-7 PCM REMOVAL/INSTALLATION [FS].)
		No	Go to next step.
12	<b>VERIFY AFTER REPAIR PROCEDURE</b> <ul style="list-style-type: none"> <li>Perform "After Repair Procedure". (See 01-02B-9 AFTER REPAIR PROCEDURE [FS].)</li> <li>Is there any DTC present?</li> </ul>	Yes	Go to applicable DTC inspection.
		No	Troubleshooting completed.

## DTC P0505 [FS]

A3U010201087W02

DTC P0505	IAC valve circuit malfunction
<b>DETECTION CONDITION</b>	<ul style="list-style-type: none"> <li>PCM monitors IAC valve circuit current while IAC duty is within <b>18—70 %</b>. If PCM detects IAC valve circuit current <b>below 100 mA (25 °C {77 °F})</b> or <b>above 4.5 A (25 °C {77 °F})</b> for <b>1 second</b>, PCM determines that IAC valve circuit has malfunction.</li> </ul> <p><b>Diagnostic support note</b></p> <ul style="list-style-type: none"> <li>This is a continuous monitor (CCM).</li> <li>MIL illuminates if PCM detects the above malfunction condition during first drive cycle. Therefore, PENDING CODE is not available.</li> <li>FREEZE FRAME DATA is available.</li> <li>DTC is stored in PCM memory.</li> </ul>
<b>POSSIBLE CAUSE</b>	<ul style="list-style-type: none"> <li>IAC valve circuit malfunction</li> <li>Short to ground between IAC valve terminal A and PCM terminal 54</li> <li>Open circuit between IAC valve terminal A and PCM terminal 54</li> <li>Short to ground between IAC valve terminal B and PCM terminal 83</li> <li>Short to power between IAC valve terminal B and PCM terminal 83</li> <li>Open circuit between IAC valve terminal B and PCM terminal 83</li> <li>Poor connection of IAC valve connector or PCM connector</li> <li>PCM malfunction</li> </ul>

## ON-BOARD DIAGNOSTIC [ENGINE CONTROL SYSTEM (FS)]

### Diagnostic procedure

STEP	INSPECTION	ACTION	
1	<b>VERIFY FREEZE FRAME DATA HAS BEEN RECORDED</b> <ul style="list-style-type: none"> <li>• Has FREEZE FRAME DATA been recorded?</li> </ul>	Yes	Go to next step.
		No	Record FREEZE FRAME DATA on repair order, then go to next step.
2	<b>VERIFY RELATED REPAIR INFORMATION AVAILABILITY</b> <ul style="list-style-type: none"> <li>• Check for related Service Bulletins availability.</li> <li>• Is any repair information available?</li> </ul>	Yes	Perform repair or diagnosis according to available repair information. <ul style="list-style-type: none"> <li>• If vehicle is not repaired, go to next step.</li> </ul>
		No	Go to next step.
3	<b>CLASSIFY INTERMITTENT CONCERN OR CONTINUOUS CONCERN</b> <ul style="list-style-type: none"> <li>• Clear DTC using WDS or equivalent.</li> <li>• Start engine and warm it up completely.</li> <li>• Is same DTC detected?</li> </ul>	Yes	Go to next step.
		No	Go to intermittent concern. (See 01-03B-4 INTERMITTENT CONCERN TROUBLESHOOTING [FS].)
4	<b>INSPECT IAC VALVE CONNECTOR FOR POOR CONNECTION</b> <ul style="list-style-type: none"> <li>• Turn ignition key to OFF.</li> <li>• Disconnect IAC valve connector.</li> <li>• Check for poor connection (damaged/pulled-out terminals, corrosion, etc.).</li> <li>• Are there any malfunctions?</li> </ul>	Yes	Repair or replace terminal, then go to Step 14.
		No	Go to next step.
5	<b>INSPECT IAC VALVE ELECTRICAL MALFUNCTION</b> <ul style="list-style-type: none"> <li>• Measure resistance between IAC valve terminals A and B (part-side).</li> <li>• Is resistance <b>within 8.7— 10.5 ohms</b>?</li> </ul>	Yes	Go to next step.
		No	Replace IAC valve, then go to Step 14.
6	<b>CLASSIFY MALFUNCTION AT POWER SUPPLY CIRCUIT OR CONTROL CIRCUIT</b> <ul style="list-style-type: none"> <li>• Turn ignition key to ON (Engine OFF).</li> <li>• Measure voltage between IAC valve terminal A (harness-side) and body ground.</li> <li>• Is voltage <b>B+</b>?</li> </ul>	Yes	Malfunction at control circuit. Go to Step 10.
		No	Malfunction at power supply circuit. Go to next step.
7	<b>INSPECT PCM CONNECTOR FOR POOR CONNECTION</b> <ul style="list-style-type: none"> <li>• Turn ignition key to OFF.</li> <li>• Disconnect PCM connector.</li> <li>• Check for poor connection at terminal 54 (damaged/pulled-out terminals, corrosion, etc.).</li> <li>• Are there any malfunctions?</li> </ul>	Yes	Repair terminal, then go to Step 14.
		No	Go to next step.
8	<b>INSPECT POWER CIRCUIT FOR SHORT TO GROUND</b> <ul style="list-style-type: none"> <li>• Turn ignition key to OFF.</li> <li>• Check for continuity between IAC valve terminal A (harness-side) and body ground.</li> <li>• Is there continuity?</li> </ul>	Yes	Repair or replace harness for short to ground, then go to Step 14.
		No	Go to next step.
9	<b>INSPECT POWER CIRCUIT FOR OPEN CIRCUIT</b> <ul style="list-style-type: none"> <li>• Turn ignition key to OFF</li> <li>• Connect breakout box with PCM disconnected.</li> <li>• Check for continuity between IAC valve terminal A (harness-side) and breakout box terminal 54.</li> <li>• Is there continuity?</li> </ul>	Yes	Repair or replace harness for open circuit, then go to Step 14.
		No	Go to Step 14.
10	<b>INSPECT PCM CONNECTOR FOR POOR CONNECTION</b> <ul style="list-style-type: none"> <li>• Turn ignition key to OFF.</li> <li>• Disconnect PCM connector.</li> <li>• Check for poor connection at terminal 83 (damaged/pulled-out terminals, corrosion, etc.).</li> <li>• Are there any malfunctions?</li> </ul>	Yes	Repair terminal, then go to Step 14.
		No	Go to next step.

## ON-BOARD DIAGNOSTIC [ENGINE CONTROL SYSTEM (FS)]

STEP	INSPECTION	ACTION	
11	<b>INSPECT CONTROL CIRCUIT FOR SHORT TO POWER</b> <ul style="list-style-type: none"> <li>Turn ignition key to ON (Engine OFF).</li> <li>Measure voltage between IAC valve terminal B (harness-side) and body ground.</li> <li>Is voltage <b>B+</b>?</li> </ul>	Yes	Repair or replace harness for short to power, then go to Step 14.
		No	Go to next step.
12	<b>INSPECT CONTROL CIRCUIT FOR SHORT TO GROUND</b> <ul style="list-style-type: none"> <li>Turn ignition key to OFF.</li> <li>Check for continuity between IAC valve terminal B (harness-side) and body ground.</li> <li>Is there continuity?</li> </ul>	Yes	Repair or replace harness for short to ground, then go to Step 14.
		No	Go to next step.
13	<b>INSPECT CONTROL CIRCUIT MALFUNCTION FOR OPEN CIRCUIT</b> <ul style="list-style-type: none"> <li>Connect breakout box with PCM disconnected.</li> <li>Check for continuity between IAC valve terminal B (harness-side) and breakout box terminal 83.</li> <li>Is there continuity?</li> </ul>	Yes	Repair or replace harness for open, then go to next step.
		No	Go to next step.
14	<b>VERIFY TROUBLESHOOTING OF DTC P0505 COMPLETED</b> <ul style="list-style-type: none"> <li>Make sure to reconnect all disconnected connectors.</li> <li>Clear DTC using WDS or equivalent.</li> <li>Start engine and warm it up completely.</li> <li>Is same DTC present?</li> </ul>	Yes	Replace PCM, then go to next step.
		No	Go to next step.
15	<b>VERIFY AFTER REPAIR PROCEDURE</b> <ul style="list-style-type: none"> <li>Perform "After Repair Procedure". (See 01-02B-9 AFTER REPAIR PROCEDURE [FS].)</li> <li>Is there any DTC present?</li> </ul>	Yes	Go to applicable DTC inspection. (See 01-02B-15 DTC TABLE [FS].)
		No	Troubleshooting completed.

01-02B

### DTC P0506 [FS]

A3U010201087W03

DTC P0506	Idle control system RPM lower than expected
<b>DETECTION CONDITION</b>	<ul style="list-style-type: none"> <li>Actual idle speed is lower than expected by <b>100 rpm</b> for <b>14.1 seconds</b> when brake pedal is depressed (brake switch is ON) and steering wheel is held straight ahead (power steering pressure switch is OFF).</li> </ul> <p><b>Note</b></p> <ul style="list-style-type: none"> <li>If atmospheric pressure is <b>less than 72.0 kPa {540 mmHg, 21.3 inHg}</b> or intake air temperature is <b>below -10°C {14°F}</b>, PCM cancels diagnosis of P0506.</li> </ul> <p><b>Diagnostic support note</b></p> <ul style="list-style-type: none"> <li>This is a continuous monitor (CCM).</li> <li>MIL illuminates if PCM detects the above malfunction condition in two consecutive drive cycles.</li> <li>PENDING CODE is available if PCM detects the above malfunction condition during first drive cycle.</li> <li>FREEZE FRAME DATA is available.</li> <li>DTC is stored in PCM memory.</li> </ul>
<b>POSSIBLE CAUSE</b>	<ul style="list-style-type: none"> <li>IAC valve malfunction</li> <li>Air cleaner element clogged</li> <li>Air intake passage clogged</li> <li>A/C relay control circuit malfunction</li> <li>Generator control circuit malfunction</li> <li>Purge solenoid valve malfunction</li> <li>Low engine compression (Over capacity of blow-by gas)</li> <li>PCM malfunction</li> </ul>

### Diagnostic procedure

STEP	INSPECTION	ACTION	
1	<b>VERIFY FREEZE FRAME DATA HAS BEEN RECORDED</b> <ul style="list-style-type: none"> <li>Has FREEZE FRAME DATA been recorded?</li> </ul>	Yes	Go to next step.
		No	Record FREEZE FRAME DATA on repair order, then go to next step.

## ON-BOARD DIAGNOSTIC [ENGINE CONTROL SYSTEM (FS)]

STEP	INSPECTION	ACTION	
2	<b>VERIFY RELATED REPAIR INFORMATION AVAILABILITY</b> <ul style="list-style-type: none"> <li>Check for related Service Bulletins availability.</li> <li>Is any related repair information available?</li> </ul>	Yes	Perform repair or diagnosis according to available repair information. <ul style="list-style-type: none"> <li>If vehicle is not repaired, go to next step.</li> </ul>
		No	Go to next step.
3	<b>VERIFY RELATED PENDING OR STORED DTCs</b> <ul style="list-style-type: none"> <li>Turn ignition key to OFF, then ON (Engine OFF).</li> <li>Verify pending code or stored DTCs using WDS or equivalent.</li> <li>Are other DTCs present?</li> </ul>	Yes	Repair applicable DTCs. (See 01–02B–15 DTC TABLE [FS].)
		No	Go to next step.
4	<b>INSPECT IAC VALVE MALFUNCTION</b> <ul style="list-style-type: none"> <li>Perform IAC inspection. (See 01–13B–8 IDLE AIR CONTROL (IAC) VALVE INSPECTION [FS].)</li> <li>Is IAC valve okay?</li> </ul>	Yes	Go to next step.
		No	Replace IAC valve, then go to Step 11.
5	<b>INSPECT A/C MAGNETIC CLUTCH OPERATION</b> <ul style="list-style-type: none"> <li>Turn blower motor switch off.</li> <li>Is magnetic clutch still ON?</li> </ul>	Yes	Refer to “A/C is always on or A/C compressor runs continuously.” of ENGINE SYMPTOM TROUBLESHOOTING, then go to Step 11. (See 01–03B–45 NO.24 A/C IS ALWAYS ON OR A/C COMPRESSOR RUNS CONTINUOUSLY [FS].)
		No	Go to next step.
6	<b>INSPECT GENERATOR CONTROL CIRCUIT MALFUNCTION</b> <ul style="list-style-type: none"> <li>Turn ignition key to OFF.</li> <li>Disconnect generator connector.</li> <li>Turn ignition key to ON.</li> <li>Measure voltage between generator connector terminal D (harness-side) and body GND.</li> <li>Is voltage 0 V?</li> </ul>	Yes	Go to next step.
		No	Repair short to power circuit in generator control circuit, then go to Step 11.
7	<b>INSPECT PURGE SOLENOID VALVE CONTROL MALFUNCTION</b> <ul style="list-style-type: none"> <li>Perform purge solenoid valve. (See 01–16–12 PURGE SOLENOID VALVE INSPECTION.)</li> <li>Is purge solenoid valve okay?</li> </ul>	Yes	Go to next step.
		No	Replace purge solenoid valve, then go to Step 11.
8	<b>INSPECT AIR CLEANER ELEMENT</b> <ul style="list-style-type: none"> <li>Remove air cleaner element with engine running.</li> <li>Is engine speed increased?</li> </ul>	Yes	Replace air cleaner element, then go to Step 11.
		No	Go to next step.
9	<b>INSPECT THROTTLE BODY PASSAGE</b> <ul style="list-style-type: none"> <li>Is throttle body passage clogged?</li> </ul>	Yes	Clean or replace throttle body, then go to Step 11.
		No	Go to next step.
10	<b>INSPECT ENGINE COMPRESSION</b> <ul style="list-style-type: none"> <li>Inspect engine compression. (See 01–10B–8 COMPRESSION INSPECTION [FS].)</li> <li>Is engine compression okay?</li> </ul>	Yes	Go to next step.
		No	Overhaul engine, then go to next step.
11	<b>VERIFY TROUBLESHOOTING OF DTC P0506 COMPLETED</b> <ul style="list-style-type: none"> <li>Make sure to reconnect all disconnected connectors.</li> <li>Start engine.</li> <li>Clear DTC from PCM memory using WDS or equivalent.</li> <li>Depress brake pedal for <b>14.1 seconds or more</b>.</li> <li>Is PENDING CODE of same DTC present?</li> </ul>	Yes	Replace PCM, then go to next step.
		No	Go to next step.
12	<b>VERIFY AFTER REPAIR PROCEDURE</b> <ul style="list-style-type: none"> <li>Perform “After Repair Procedure”. (See 01–02B–9 AFTER REPAIR PROCEDURE [FS].)</li> <li>Is there any DTC present?</li> </ul>	Yes	Go to applicable DTC inspection. (See 01–02B–15 DTC TABLE [FS].)
		No	Troubleshooting completed.

# ON-BOARD DIAGNOSTIC [ENGINE CONTROL SYSTEM (FS)]

DTC P0507 [FS]

A3U010201087W04

01-02B

<b>DTC P0507</b>	<b>Idle control system RPM higher than expected</b>
<b>DETECTION CONDITION</b>	<ul style="list-style-type: none"> <li>Actual idle speed is higher than expected by <b>200 rpm</b> for <b>14.1 seconds</b>, when brake pedal is depressed (brake switch is ON) and steering wheel is held straight ahead (power steering pressure switch is OFF).</li> </ul> <p><b>Note</b></p> <ul style="list-style-type: none"> <li>If atmospheric pressure is <b>less than 72.0 kPa {540 mmHg, 21.3 inHg}</b> or intake air temperature is <b>below -10°C {14°F}</b>, PCM cancels diagnosis of P0507.</li> </ul> <p><b>Diagnostic support note</b></p> <ul style="list-style-type: none"> <li>This is a continuous monitor (CCM).</li> <li>MIL illuminates if PCM detects the above malfunction condition in two consecutive drive cycles.</li> <li>PENDING CODE is available if PCM detects the above malfunction condition during first drive cycle.</li> <li>FREEZE FRAME DATA is available.</li> <li>DTC is stored in PCM memory.</li> </ul>
<b>POSSIBLE CAUSE</b>	<ul style="list-style-type: none"> <li>IAC valve malfunction</li> <li>Accelerator cable misadjustment</li> <li>Actuator cable misadjustment</li> <li>Throttle valve malfunction</li> <li>Vacuum hose misconnection</li> <li>PCM malfunction</li> </ul>

**Diagnostic procedure**

STEP	INSPECTION		ACTION
1	<b>VERIFY FREEZE FRAME DATA HAS BEEN RECORDED</b> <ul style="list-style-type: none"> <li>Has FREEZE FRAME DATA been recorded?</li> </ul>	Yes	Go to next step.
		No	Record FREEZE FRAME DATA on repair order, then go to next step.
2	<b>VERIFY RELATED REPAIR INFORMATION AVAILABILITY</b> <ul style="list-style-type: none"> <li>Check for related Service Bulletins availability.</li> <li>Is any related repair information available?</li> </ul>	Yes	Perform repair or diagnosis according to available repair information. <ul style="list-style-type: none"> <li>If vehicle is not repaired, go to next step.</li> </ul>
		No	Go to next step.
3	<b>VERIFY RELATED PENDING OR STORED DTCS</b> <ul style="list-style-type: none"> <li>Turn ignition key to OFF, then start engine.</li> <li>Verify pending code or stored DTCs using WDS or equivalent.</li> <li>Are other DTCs present?</li> </ul>	Yes	Repair applicable DTCs. (See 01-02B-15 DTC TABLE [FS].)
		No	Go to next step.
4	<b>INSPECT IAC VALVE MALFUNCTION</b> <ul style="list-style-type: none"> <li>Perform IAC inspection. (See 01-13B-8 IDLE AIR CONTROL (IAC) VALVE INSPECTION [FS].)</li> <li>Is IAC valve okay?</li> </ul>	Yes	Go to next step.
		No	Replace IAC valve, then go to Step 9.
5	<b>INSPECT ACCELERATOR CABLE FREE PLAY</b> <ul style="list-style-type: none"> <li>Turn ignition key to OFF.</li> <li>Is accelerator cable free play okay? (See 01-13B-17 ACCELERATOR CABLE INSPECTION [FS].)</li> </ul>	Yes	Go to next step.
		No	Adjust accelerator cable free play, then go to Step 9. (See 01-13B-17 ACCELERATOR CABLE ADJUSTMENT [FS].)
6	<b>INSPECT ACTUATOR CABLE FREE PLAY</b> <ul style="list-style-type: none"> <li>Is actuator cable adjustment okay?</li> </ul>	Yes	Go to next step.
		No	Adjust actuator cable free play, then go to Step 9.
7	<b>INSPECT VACUUM HOSE CONNECTION</b> <ul style="list-style-type: none"> <li>Are vacuum hoses connected accurately? (See 01-13B-5 VACUUM HOSE ROUTING DIAGRAM [FS].)</li> </ul>	Yes	Go to next step.
		No	Reconnect vacuum hose accurately, then go to Step 9.
8	<b>VISUAL INSPECT THROTTLE VALVE</b> <ul style="list-style-type: none"> <li>Remove throttle body.</li> <li>Is throttle valve fully closed?</li> </ul>	Yes	Go to next step.
		No	Clean or replace throttle body, then go to next step.

# ON-BOARD DIAGNOSTIC [ENGINE CONTROL SYSTEM (FS)]

STEP	INSPECTION	ACTION
9	<b>VERIFY TROUBLESHOOTING OF DTC P0507 COMPLETED</b> <ul style="list-style-type: none"> <li>• Make sure to reconnect all disconnected connectors.</li> <li>• Start engine.</li> <li>• Clear DTC from PCM memory using WDS or equivalent.</li> <li>• Depress brake pedal for <b>14.1 seconds or more</b>.</li> <li>• Is PENDING CODE of same DTC present?</li> </ul>	Yes Replace PCM, then go to next step.
		No Go to next step.
10	<b>VERIFY AFTER REPAIR PROCEDURE</b> <ul style="list-style-type: none"> <li>• Perform "After Repair Procedure". (See 01-02B-9 AFTER REPAIR PROCEDURE [FS].)</li> <li>• Is there any DTC present?</li> </ul>	Yes Go to applicable DTC inspection. (See 01-02B-15 DTC TABLE [FS].)
		No Troubleshooting completed.

## DTC P0550 [FS]

A3U010201087W05

DTC P0550	PSP switch circuit malfunction
<b>DETECTION CONDITION</b>	<ul style="list-style-type: none"> <li>• PCM monitors PSP switch signal at PCM terminal 31. If input voltage is low (switch stays on) for <b>1 minute</b> when the VSS is <b>above 60.2 km/h {37.4 mph}</b> and ECT is <b>above 60°C {140°F}</b>, PCM determines that PSP switch circuit has malfunction.</li> </ul> <p><b>Diagnostic support note</b></p> <ul style="list-style-type: none"> <li>• This is a continuous monitor (CCM).</li> <li>• MIL illuminates if PCM detects the above malfunction condition in two consecutive drive cycles.</li> <li>• PENDING CODE is available if PCM detects the above malfunction condition during first drive cycle.</li> <li>• FREEZE FRAME DATA is available.</li> <li>• DTC is stored in PCM memory.</li> </ul>
<b>POSSIBLE CAUSE</b>	<ul style="list-style-type: none"> <li>• PSP switch malfunction</li> <li>• Short to ground between PSP switch terminal and PCM terminal 31</li> <li>• PCM malfunction</li> </ul>

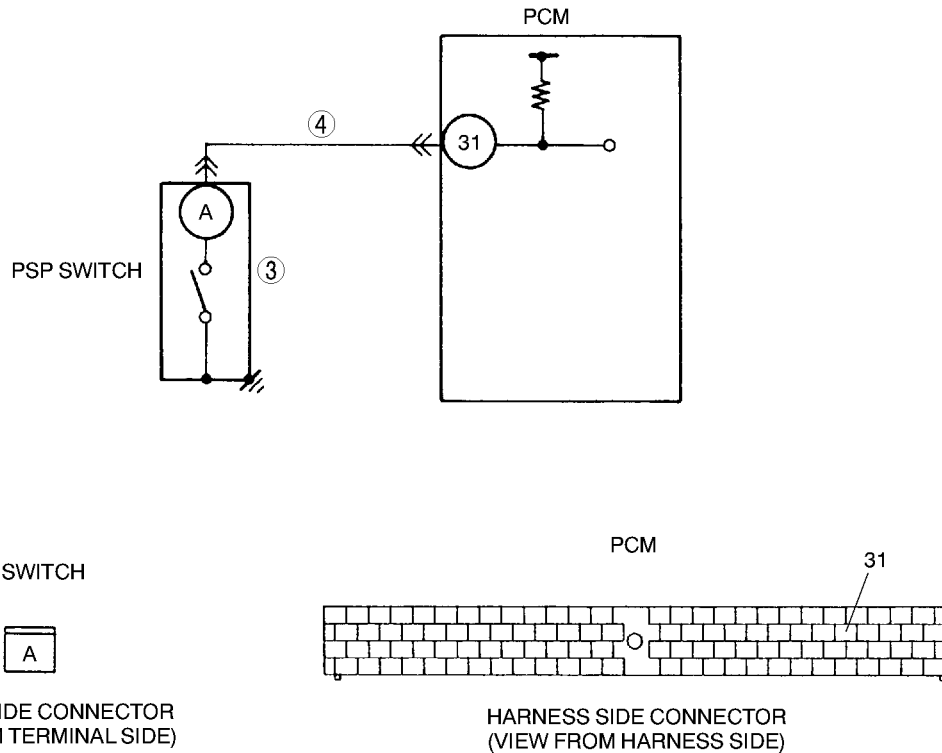

## ON-BOARD DIAGNOSTIC [ENGINE CONTROL SYSTEM (FS)]

### Diagnostic procedure

STEP	INSPECTION	ACTION
1	<b>VERIFY FREEZE FRAME DATA HAS BEEN RECORDED</b> <ul style="list-style-type: none"> <li>Has FREEZE FRAME DATA been recorded?</li> </ul>	Yes Go to next step.
		No Record FREEZE FRAME DATA on repair order, then go to next step.
2	<b>VERIFY RELATED REPAIR INFORMATION AVAILABILITY</b> <ul style="list-style-type: none"> <li>Check for related Service Bulletins availability.</li> <li>Is any related repair information available?</li> </ul>	Yes Perform repair or diagnosis according to available repair information. <ul style="list-style-type: none"> <li>If vehicle is not repaired, go to next step.</li> </ul>
		No Go to next step.
3	<b>INSPECT PSP SWITCH</b> <ul style="list-style-type: none"> <li>Perform PSP switch inspection (See 01-40B-44 POWER STEERING PRESSURE (PSP) SWITCH INSPECTION [FS].)</li> <li>Is PSP switch okay?</li> </ul>	Yes Go to next step.
		No Replace the PSP switch, then go to Step 5.
4	<b>INSPECT PSP SWITCH SIGNAL CIRCUIT FOR SHORT TO GROUND</b> <ul style="list-style-type: none"> <li>Disconnect PCM connector.</li> <li>Check for continuity between PSP switch terminal (harness-side) and body ground.</li> <li>Is there continuity?</li> </ul>	Yes Repair or replace harness for short to ground, then go to next step.
		No Go to next step.
5	<b>VERIFY TROUBLESHOOTING OF DTC P0550 COMPLETED</b> <ul style="list-style-type: none"> <li>Make sure to reconnect all disconnected connectors.</li> <li>Start engine.</li> <li>Clear DTC from PCM memory using WDS or equivalent.</li> <li>Drive vehicle <b>above 60.2 km/h {37.4 mph}</b> for <b>1 minute</b>.</li> <li>Verify that ECT PID is <b>above 60°C {140°F}</b> using WDS or equivalent.</li> <li>Is PENDING CODE of same DTC present?</li> </ul>	Yes Replace PCM, then go to next step.
		No Go to next step.
6	<b>VERIFY AFTER REPAIR PROCEDURE</b> <ul style="list-style-type: none"> <li>Perform "After Repair Procedure". (See 01-02B-9 AFTER REPAIR PROCEDURE [FS].)</li> <li>Is there any DTC present?</li> </ul>	Yes Go to applicable DTC inspection. (See 01-02B-15 DTC TABLE [FS].)
		No Troubleshooting completed.

01-02B

### DTC P0660 [FS]

A3U010201088W01

DTC P0660	VICS solenoid valve circuit malfunction
<b>DETECTION CONDITION</b>	<ul style="list-style-type: none"> <li>PCM monitors input voltages from VICS solenoid valve while engine running. If voltage at PCM terminal 19 remains low or high, PCM determines that VICS solenoid valve circuit has malfunction.</li> </ul> <p><b>Diagnostic support note</b></p> <ul style="list-style-type: none"> <li>This is a intermittent monitor (CCM)</li> <li>PCM detects the above malfunction condition in two consecutive drive cycles.</li> <li>PENDING CODE is available if PCM detects the above malfunction condition during first drive cycle.</li> <li>FREEZE FRAME DATA is available.</li> <li>DTC is stored in PCM memory.</li> </ul>
<b>POSSIBLE CAUSE</b>	<ul style="list-style-type: none"> <li>VICS solenoid valve malfunction</li> <li>Connector or terminal malfunction</li> <li>Short to ground in wiring between VICS solenoid valve terminal B and PCM terminal 19</li> <li>Open circuit in wiring between main relay terminal D and VICS solenoid valve terminal A</li> <li>Open circuit in wiring between VICS solenoid valve terminal B and PCM terminal 19</li> <li>Short to power circuit between VICS solenoid valve terminal B and PCM terminal 19</li> <li>PCM malfunction</li> </ul>

# ON-BOARD DIAGNOSTIC [ENGINE CONTROL SYSTEM (FS)]

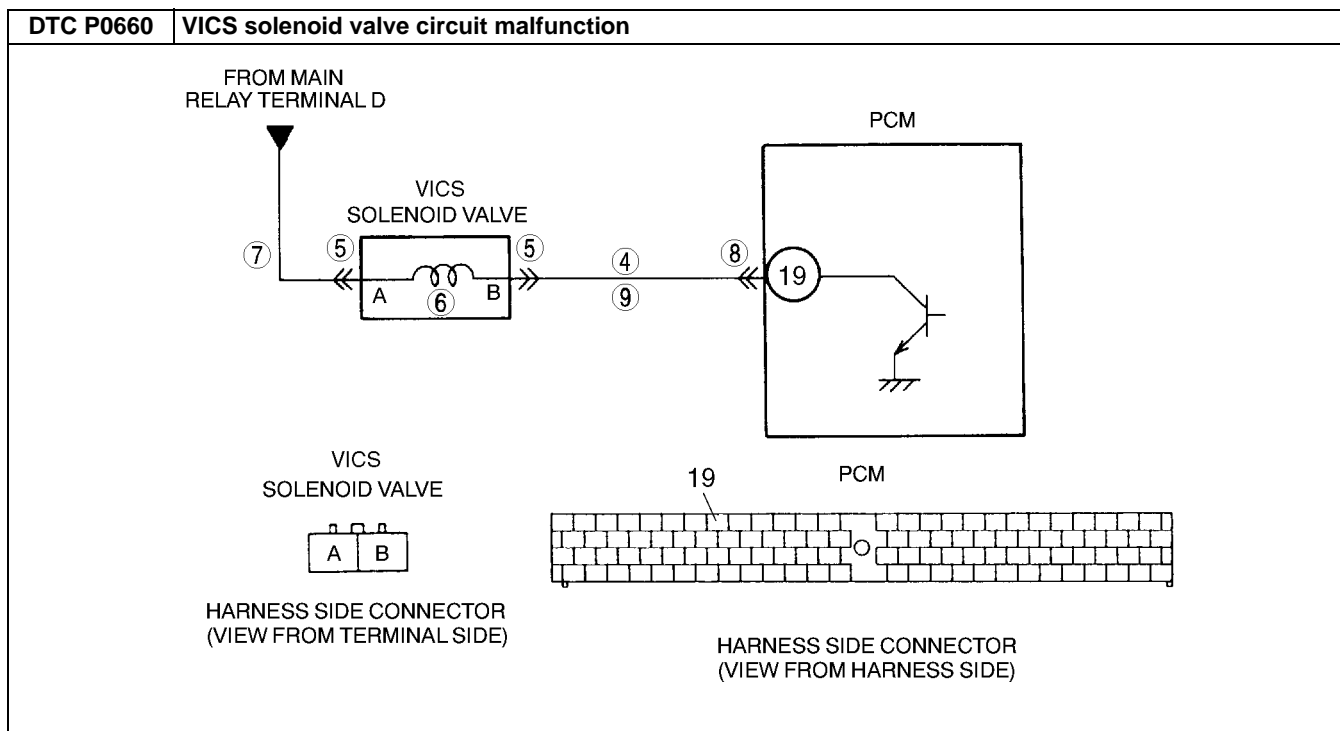

### Diagnostic procedure

STEP	INSPECTION		ACTION
1	<b>VERIFY RELATED REPAIR INFORMATION AVAILABILITY</b> <ul style="list-style-type: none"> <li>Check for related Service Bulletins availability.</li> <li>Is any related repair information available?</li> </ul>	Yes	Perform repair or diagnosis according to available repair information. <ul style="list-style-type: none"> <li>If vehicle is not repaired, go to next step.</li> </ul>
		No	Go to next step.
2	<b>CLASSIFY INTERMITTENT CONCERN OR CONTINUOUS CONCERN</b> <ul style="list-style-type: none"> <li>Start engine.</li> <li>Increase engine speed <b>above 4,750 rpm</b>.</li> <li>Is <b>PENDING CODE</b> same DTC present?</li> </ul>	Yes	Go to next step.
		No	Intermittent concern exists. Go to <b>INTERMITTENT CONCERN TROUBLESHOOTING</b> procedure. (See 01-03B-4 <b>INTERMITTENT CONCERN TROUBLESHOOTING [FS]</b> .)
3	<b>CLASSIFY OPEN CIRCUIT OR SHORT TO GROUND MALFUNCTION</b> <ul style="list-style-type: none"> <li>Disconnect VICS solenoid valve tube at solenoid side that connects to VICS solenoid valve.</li> <li>Connect vacuum pump to VICS solenoid valve.</li> <li>Apply vacuum.</li> <li>Wait for <b>5 seconds</b>.</li> <li>Is vacuum maintained?</li> </ul>	Yes	Go to Step 5.
		No	Go to next step.
4	<b>INSPECT PASSAGE CONTROL OF VICS SOLENOID VALVE</b> <ul style="list-style-type: none"> <li>Turn ignition key to OFF.</li> <li>Disconnect VICS solenoid valve connector.</li> <li>Apply vacuum and wait for <b>5 seconds</b>.</li> <li>Is vacuum maintained?</li> </ul>	Yes	Repair or replace harness between solenoid valve terminal B and PCM terminal 19 for short to ground, then go to Step 10.
		No	Replace VICS solenoid valve, then go to Step 10.
5	<b>INSPECT VICS SOLENOID VALVE CONNECTOR FOR POOR CONNECTION</b> <ul style="list-style-type: none"> <li>Turn ignition key to OFF.</li> <li>Check for poor connection (damaged/pulled-out pins, corrosion, etc.).</li> <li>Is there malfunction?</li> </ul>	Yes	Repair or replace terminal, then go to Step 10.
		No	Go to next step.
6	<b>INSPECT VICS SOLENOID VALVE</b> <ul style="list-style-type: none"> <li>Measure resistance between VICS solenoid valve terminals (part-side).</li> <li>Is resistance <b>within 22—26 ohms</b>?</li> </ul>	Yes	Go to next step.
		No	Replace VICS solenoid valve, then go to Step 10.



## ON-BOARD DIAGNOSTIC [ENGINE CONTROL SYSTEM (FS)]

STEP	INSPECTION	ACTION	
7	<b>INSPECT VICS SOLENOID VALVE POWER SUPPLY CIRCUIT FOR OPEN CIRCUIT</b> <ul style="list-style-type: none"> <li>• Turn ignition key to ON (Engine OFF).</li> <li>• Measure voltage between VICS solenoid valve terminal A (harness-side) and body ground.</li> <li>• Is voltage <b>B+</b>?</li> </ul>	Yes	Go to next step.
		No	Repair or replace harness for open, then go to Step 10.
8	<b>INSPECT PCM CONNECTOR FOR POOR CONNECTION</b> <ul style="list-style-type: none"> <li>• Turn ignition key to OFF.</li> <li>• Disconnect PCM connector.</li> <li>• Check for poor connection at terminal 19. (damaged/pulled-out pins, corrosion, etc.).</li> <li>• Is there malfunction?</li> </ul>	Yes	Repair terminal, then go to Step 10.
		No	Go to next step.
9	<b>INSPECT VICS SOLENOID VALVE CONTROL CIRCUIT FOR OPEN CIRCUIT</b> <ul style="list-style-type: none"> <li>• Connect VICS solenoid valve connector.</li> <li>• Connect breakout box with PCM disconnected.</li> <li>• Turn ignition key to ON (Engine OFF).</li> <li>• Measure voltage between breakout box terminal 19 and body ground.</li> <li>• Is voltage <b>B+</b>?</li> </ul>	Yes	Go to next step.
		No	Repair or replace harness for open, then go to next step.
10	<b>VERIFY TROUBLESHOOTING OF DTC P0660 COMPLETED</b> <ul style="list-style-type: none"> <li>• Make sure to reconnect all disconnected connectors.</li> <li>• Turn ignition key to ON (Engine OFF).</li> <li>• Clear DTC from PCM memory using WDS or equivalent.</li> <li>• Start engine.</li> <li>• Increase engine speed <b>above 4,750 rpm</b>.</li> <li>• Is PENDING CODE of same DTC present?</li> </ul>	Yes	Replace PCM, then go to next step.
		No	Go to next step.
11	<b>VERIFY AFTER REPAIR PROCEDURE</b> <ul style="list-style-type: none"> <li>• Perform "After Repair Procedure". (See 01-02B-9 AFTER REPAIR PROCEDURE [FS].)</li> <li>• Is there any DTC present?</li> </ul>	Yes	Go to applicable DTC inspection. (See 01-02B-15 DTC TABLE [FS].)
		No	Troubleshooting completed.

01-02B

# ON-BOARD DIAGNOSTIC [ENGINE CONTROL SYSTEM (FS)]

DTC P0703 [FS]

A3U010201089W01

<b>DTC P0703</b>	<b>Brake switch input malfunction</b>
<b>DETECTION CONDITION</b>	<ul style="list-style-type: none"> <li>PCM monitors changes in input voltage from brake switch. If PCM does not detect PCM terminal 92 voltage changes while accelerating and decelerating <b>10 times</b> repeatedly, it determines that brake switch circuit has malfunction.</li> </ul> <p><b>Diagnostic support note</b></p> <ul style="list-style-type: none"> <li>This is a continuous monitor (CCM).</li> <li>MIL illuminates if PCM detects the above malfunction condition in two consecutive drive cycles.</li> <li>PENDING CODE is available if PCM detects the above malfunction condition during first drive cycle.</li> <li>FREEZE FRAME DATA is available.</li> <li>DTC is stored in PCM memory.</li> </ul>
<b>POSSIBLE CAUSE</b>	<ul style="list-style-type: none"> <li>Brake switch malfunction</li> <li>Open harness between brake switch terminal B and PCM connector terminal 92</li> <li>PCM malfunction</li> </ul>

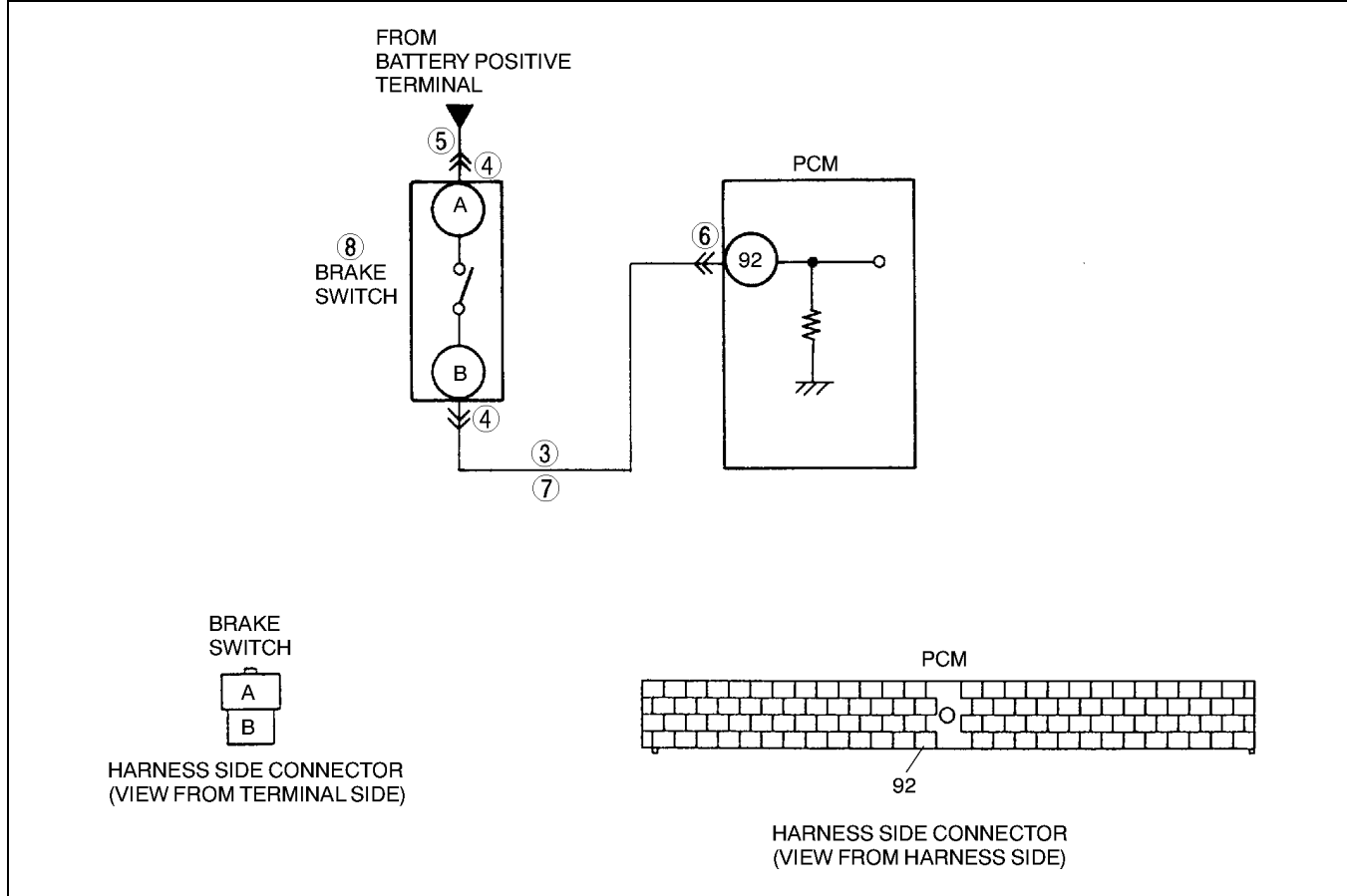

**Diagnostic procedure**

STEP	INSPECTION		ACTION
1	<b>VERIFY FREEZE FRAME DATA HAS BEEN RECORDED</b> <ul style="list-style-type: none"> <li>Has FREEZE FRAME DATA been recorded?</li> </ul>	Yes	Go to next step.
		No	Record FREEZE FRAME DATA on repair order, then go to next step.
2	<b>VERIFY RELATED REPAIR INFORMATION AVAILABILITY</b> <ul style="list-style-type: none"> <li>Check for related Service Bulletins availability.</li> <li>Is any related repair information available?</li> </ul>	Yes	Perform repair or diagnosis according to available repair information. <ul style="list-style-type: none"> <li>If vehicle is not repaired, go to next step.</li> </ul>
		No	Go to next step.
3	<b>INSPECT BRAKE SWITCH SIGNAL CIRCUIT FOR SHORT TO POWER</b> <ul style="list-style-type: none"> <li>Measure voltage between brake switch connector terminal B and body ground.</li> <li>Is voltage B+?</li> </ul>	Yes	Repair or replace harness for short to power, then go to Step 9.
		No	Go to Next step.

## ON-BOARD DIAGNOSTIC [ENGINE CONTROL SYSTEM (FS)]

STEP	INSPECTION	ACTION
4	<b>INSPECT BRAKE SWITCH CONNECTOR FOR POOR CONNECTION</b> <ul style="list-style-type: none"> <li>Turn ignition switch to OFF.</li> <li>Disconnect brake switch connector.</li> <li>Check for poor connection (damaged/pulled-out terminals, corrosion, etc.).</li> <li>Is there malfunction?</li> </ul>	Yes Repair or replace terminal, then go to Step 9.
		No Go to next step.
5	<b>INSPECT BRAKE SWITCH POWER CIRCUIT FOR OPEN CIRCUIT</b> <ul style="list-style-type: none"> <li>Measure voltage between brake switch connector terminal A and body ground.</li> <li>Is voltage <b>B+</b>?</li> </ul>	Yes Go to next step.
		No Repair or replace brake switch power circuit for open, then Go to Step 9.
6	<b>INSPECT PCM CONNECTOR FOR POOR CONNECTION</b> <ul style="list-style-type: none"> <li>Turn ignition switch to OFF.</li> <li>Disconnect PCM connector.</li> <li>Check for poor connection (damaged/pulled-out terminals, corrosion, etc.).</li> <li>Is there any malfunction?</li> </ul>	Yes Repair terminal, then go to Step 9.
		No Go to next step.
7	<b>INSPECT BRAKE SWITCH SIGNAL CIRCUIT FOR OPEN CIRCUIT</b> <ul style="list-style-type: none"> <li>Connect breakout box with PCM connector disconnected.</li> <li>Connect brake switch connector.</li> <li>Turn ignition switch to ON (engine OFF).</li> <li>Depress brake pedal and measure voltage between breakout box terminal 92 and body ground.</li> <li>Is voltage <b>B+</b>?</li> </ul>	Yes Go to next step.
		No Repair or replace harness for open, then go to Step 9.
8	<b>INSPECT BRAKE SWITCH</b> <ul style="list-style-type: none"> <li>Perform brake switch inspection. (See 04-11-5 BRAKE SWITCH INSPECTION.)</li> <li>Is brake switch okay?</li> </ul>	Yes Go to next step.
		No Replace brake switch, then go to next step.
9	<b>VERIFY TROUBLESHOOTING OF DTC P0703 COMPLETED</b> <ul style="list-style-type: none"> <li>Make sure to reconnect all disconnected connectors.</li> <li>Clear DTC from memory using WDS or equivalent.</li> <li>Drive vehicle <b>30 km/h {18.6 mph} or more.</b></li> <li>Depress and release brake pedal <b>more than 10 times</b> while driving vehicle.</li> <li>Is PENDING CODE of same DTC present?</li> </ul>	Yes Replace PCM, then go to next step.
		No Go to next step.
10	<b>VERIFY AFTER REPAIR PROCEDURE</b> <ul style="list-style-type: none"> <li>Perform "After Repair Procedure". (See 01-02B-9 AFTER REPAIR PROCEDURE [FS].)</li> <li>Is there any DTC present?</li> </ul>	Yes Go to applicable DTC inspection. (See 01-02B-15 DTC TABLE [FS].)
		No Troubleshooting completed.

01-02B

### DTC P0704 [FS]

A3U010201089W02

DTC P0704	Clutch switch circuit malfunction
<b>DETECTION CONDITION</b>	<ul style="list-style-type: none"> <li>PCM monitors changes in input voltage from the clutch switch. If PCM does not detect PCM terminal 6 voltage changes while running vehicle with vehicle speed <b>above 30 km/h {19 mph}</b> and stopping vehicle <b>10 times</b> repeatedly, it determines that clutch switch circuit has malfunction.</li> </ul> <p><b>Diagnostic support note</b></p> <ul style="list-style-type: none"> <li>This is a continuous monitor (CCM).</li> <li>MIL illuminates if PCM detects the above the above malfunction condition in two consecutive drive cycles.</li> <li>PENDING CODE is available if PCM detects the above malfunction condition during first drive cycle.</li> <li>FREEZE FRAME DATA is available.</li> <li>DTC is stored in PCM memory.</li> </ul>
<b>POSSIBLE CAUSE</b>	<ul style="list-style-type: none"> <li>CLT switch malfunction</li> <li>Open harness between clutch switch terminal A and PCM terminal 6</li> <li>PCM malfunction</li> </ul>

# ON-BOARD DIAGNOSTIC [ENGINE CONTROL SYSTEM (FS)]

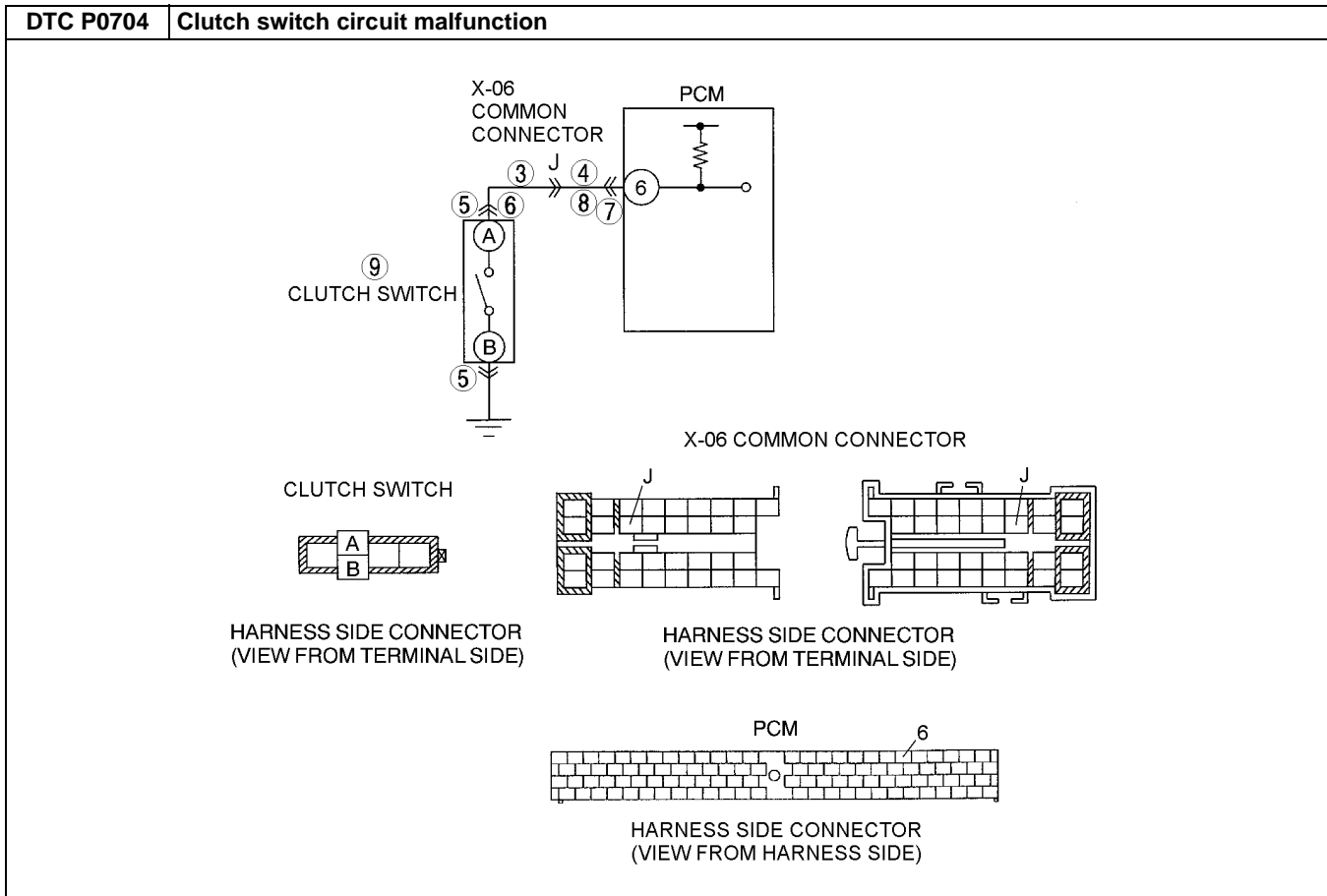

## Diagnostic procedure

STEP	INSPECTION		ACTION
1	<b>VERIFY FREEZE FRAME DATA HAS BEEN RECORDED</b> <ul style="list-style-type: none"> <li>Has FREEZE FRAME DATA been recorded?</li> </ul>	Yes	Go to next step.
		No	Record FREEZE FRAME DATA on repair order, then go to next step.
2	<b>VERIFY RELATED REPAIR INFORMATION AVAILABILITY</b> <ul style="list-style-type: none"> <li>Check for related Service Bulletins availability.</li> <li>Is any related repair information available?</li> </ul>	Yes	Perform repair or diagnosis according to available repair information. <ul style="list-style-type: none"> <li>If vehicle is not repaired, go to next step.</li> </ul>
		No	Go to next step.
3	<b>INSPECT X-06 COMMON CONNECTOR CIRCUIT FOR SHORT TO POWER</b> <ul style="list-style-type: none"> <li>Disconnect X-06 common connector.</li> <li>Turn ignition key to ON (engine OFF).</li> <li>Measure voltage between X-06 common connector male terminal J and body ground.</li> <li>Is voltage <b>B+</b>?</li> </ul>	Yes	Repair or replace harness for short to power, then go to Step 10.
		No	Go to next step.
4	<b>INSPECT CLUTCH SWITCH SIGNAL CIRCUIT FOR SHORT TO POWER</b> <ul style="list-style-type: none"> <li>Turn ignition key OFF.</li> <li>Connect breakout box with PCM connector disconnected.</li> <li>Turn ignition key to ON (engine OFF).</li> <li>Measure voltage between breakout box terminal 6 and body ground.</li> <li>Is voltage <b>B+</b>?</li> </ul>	Yes	Repair or replace harness for short to power, then go to Step 10.
		No	Go to next step.
5	<b>INSPECT CLUTCH SWITCH CONNECTOR FOR POOR CONNECTION</b> <ul style="list-style-type: none"> <li>Turn ignition key to OFF.</li> <li>Disconnect clutch switch connector.</li> <li>Check for poor connection (damaged/pilled-out terminals, corrosion, etc.).</li> <li>Is there malfunction?</li> </ul>	Yes	Repair or replace terminal, then go Step 10.
		No	Go to next step.

## ON-BOARD DIAGNOSTIC [ENGINE CONTROL SYSTEM (FS)]

STEP	INSPECTION	ACTION	
6	<b>INSPECT CLUTCH SWITCH SIGNAL CIRCUIT FOR OPEN CIRCUIT</b> <ul style="list-style-type: none"> <li>• Make sure to reconnect all disconnected connectors.</li> <li>• Turn ignition key to ON (engine OFF).</li> <li>• Measure voltage between clutch switch terminal A and body ground.</li> <li>• Is voltage <b>B+</b>?</li> </ul>	Yes	Go to next step.
		No	Repair or replace clutch switch signal circuit for open, then go to Step 10.
7	<b>INSPECT PCM CONNECTOR FOR POOR CONNECTION</b> <ul style="list-style-type: none"> <li>• Turn ignition key to OFF.</li> <li>• Disconnect PCM connector.</li> <li>• Check for poor connection at terminal 6 (damaged/pulled-out terminals, corrosion, etc.).</li> <li>• Is there malfunction?</li> </ul>	Yes	Repair terminal, then go to Step 10.
		No	Go to next step.
8	<b>INSPECT X-06 COMMON CONNECTOR CIRCUIT FOR OPEN CIRCUIT</b> <ul style="list-style-type: none"> <li>• Disconnect X-06 common connector.</li> <li>• Turn ignition key to ON (engine OFF).</li> <li>• Depress clutch pedal and measure voltage between X-06 common connector male terminal J and body ground.</li> <li>• Is voltage <b>B+</b>?</li> </ul>	Yes	Go to next step.
		No	Repair or replace harness for open, then go to Step 10.
9	<b>INSPECT CLUTCH SWITCH</b> <ul style="list-style-type: none"> <li>• Perform clutch switch inspection. (See 01-40B-42 CLUTCH SWITCH INSPECTION [FS].)</li> <li>• Is clutch switch okay?</li> </ul>	Yes	Go to next step.
		No	Replace clutch switch, then go to next step.
10	<b>VERIFY TROUBLESHOOTING OF DTC P0704 COMPLETED</b> <ul style="list-style-type: none"> <li>• Make sure to reconnect all disconnected connectors.</li> <li>• Start engine.</li> <li>• Clear DTC from PCM memory using WDS or equivalent.</li> <li>• Drive vehicle <b>above 30 km/h {19 mph}</b> and stop vehicle.</li> <li>• Depress and release clutch pedal <b>more than 10 times</b> during drive cycle.</li> <li>• Is PENDING CODE of same DTC present?</li> </ul>	Yes	Replace PCM, then go to next step.
		No	Go to next step.
11	<b>VERIFY AFTER REPAIR PROCEDURE</b> <ul style="list-style-type: none"> <li>• Perform "After Repair Procedure". (See 01-02B-9 AFTER REPAIR PROCEDURE [FS].)</li> <li>• Is there any DTC present?</li> </ul>	Yes	Go to applicable DTC inspection. (See 01-02B-15 DTC TABLE [FS].)
		No	Troubleshooting completed.

01-02B

### DTC P0705 [FS]

A3U010201089W03

DTC P0705	Neutral switch circuit malfunction
<b>DETECTION CONDITION</b>	<ul style="list-style-type: none"> <li>• PCM monitors changes in input voltage from neutral switch. If PCM does not detect PCM terminal 64 voltage changes when clutch pedal is depressed <b>10 times</b> while driving with vehicle speed <b>above 30 km/h {19 mph}</b> and vehicle stopped repeatedly, it determines that neutral switch circuit has malfunction.</li> </ul> <p><b>Diagnostic support note</b></p> <ul style="list-style-type: none"> <li>• This is a continuous monitor (CCM).</li> <li>• MIL illuminates if PCM detects the above the above malfunction condition in two consecutive drive cycles.</li> <li>• PENDING CODE is available if PCM detects the above malfunction condition during first drive cycle.</li> <li>• FREEZE FRAME DATA is available.</li> <li>• DTC is stored in PCM memory.</li> </ul>
<b>POSSIBLE CAUSE</b>	<ul style="list-style-type: none"> <li>• Neutral switch malfunction</li> <li>• Open harness between neutral switch terminal A and PCM terminal 64</li> <li>• PCM malfunction</li> </ul>

# ON-BOARD DIAGNOSTIC [ENGINE CONTROL SYSTEM (FS)]

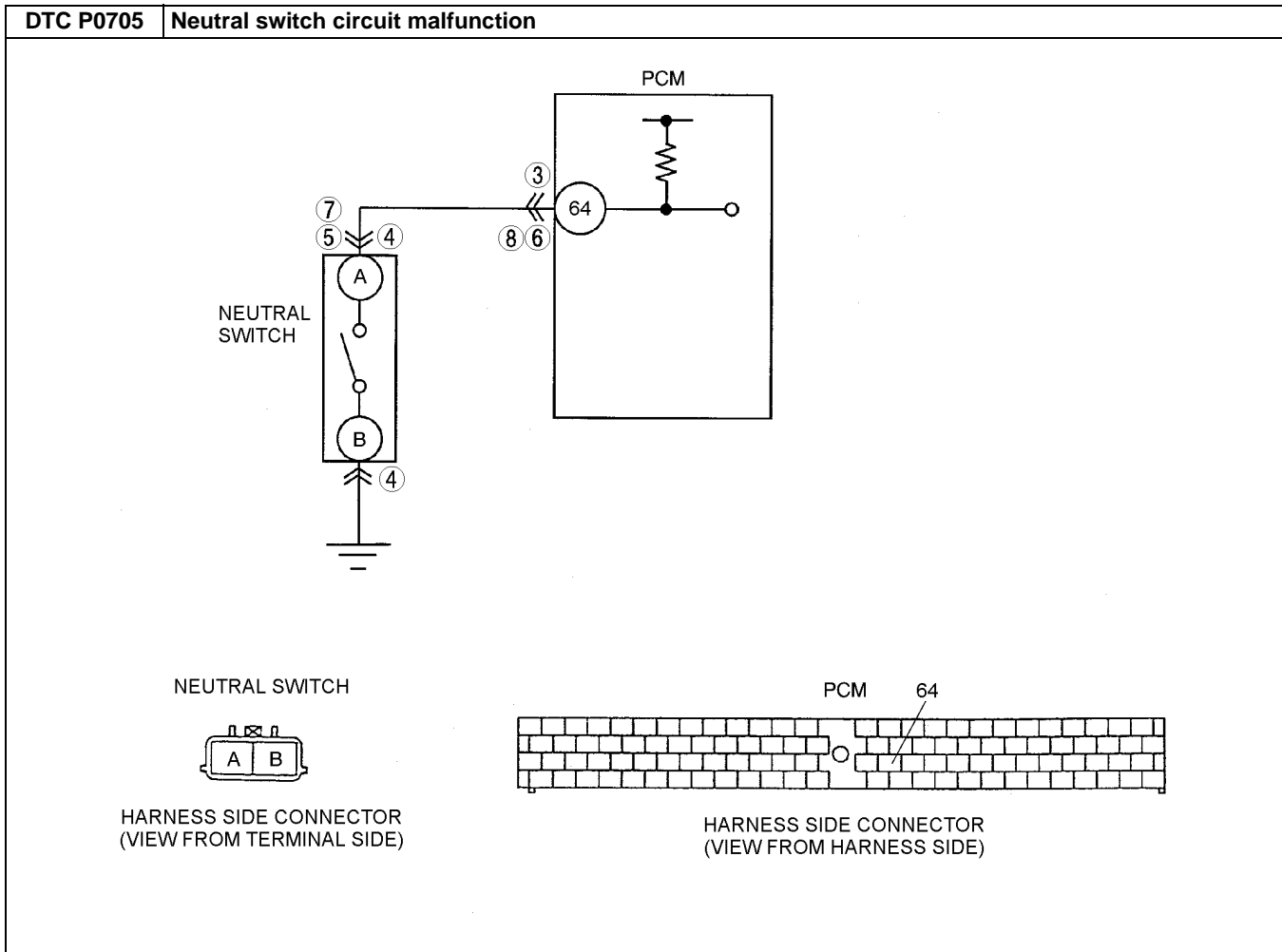

### Diagnostic procedure

STEP	INSPECTION		ACTION
1	<b>VERIFY FREEZE FRAME DATA HAS BEEN RECORDED</b> <ul style="list-style-type: none"> <li>• Has FREEZE FRAME DATA been recorded?</li> </ul>	Yes	Go to next step.
		No	Record FREEZE FRAME DATA on repair order, then go to next step.
2	<b>VERIFY RELATED REPAIR INFORMATION AVAILABILITY</b> <ul style="list-style-type: none"> <li>• Check for related Service Bulletins availability.</li> <li>• Is any related repair information available?</li> </ul>	Yes	Perform repair or diagnosis according to available repair information. <ul style="list-style-type: none"> <li>• If vehicle is not repaired, go to next step.</li> </ul>
		No	Go to next step.
3	<b>INSPECT NEUTRAL SWITCH SIGNAL CIRCUIT FOR SHORT TO POWER</b> <ul style="list-style-type: none"> <li>• Connect breakout box with PCM connector disconnected.</li> <li>• Disconnect neutral switch connector.</li> <li>• Turn ignition key to ON (engine OFF).</li> <li>• Measure voltage between breakout box terminal 64 (harness-side) and body ground.</li> <li>• Is voltage <b>B+</b>?</li> </ul>	Yes	Repair or replace harness for short to power, then go to Step 9.
		No	Go to next step.
4	<b>INSPECT NEUTRAL SWITCH CONNECTOR FOR POOR CONNECTION</b> <ul style="list-style-type: none"> <li>• Turn ignition key to OFF.</li> <li>• Disconnect neutral switch connector.</li> <li>• Check for poor connection (damaged/pulled-out terminals, corrosion, etc.).</li> <li>• Is there malfunction?</li> </ul>	Yes	Repair or replace terminal, then go Step 9.
		No	Go to next step.

## ON-BOARD DIAGNOSTIC [ENGINE CONTROL SYSTEM (FS)]

STEP	INSPECTION	ACTION	
5	<b>INSPECT NEUTRAL SWITCH SIGNAL CIRCUIT FOR OPEN CIRCUIT</b> <ul style="list-style-type: none"> <li>• Make sure to reconnect all disconnected connectors.</li> <li>• Turn ignition key to ON (engine OFF).</li> <li>• Measure voltage between neutral switch terminal A (harness-side) and body ground.</li> <li>• Is voltage <b>B+</b>?</li> </ul>	Yes	Go to next step.
		No	Repair or replace neutral switch signal circuit for open, then go to Step 9.
6	<b>INSPECT PCM CONNECTOR FOR POOR CONNECTION</b> <ul style="list-style-type: none"> <li>• Turn ignition key to OFF.</li> <li>• Disconnect PCM connector.</li> <li>• Check for poor connection at terminal 64 (damaged/pulled-out terminals, corrosion, etc.).</li> <li>• Is there malfunction?</li> </ul>	Yes	Repair terminal, then go to Step 9.
		No	Go to next step.
7	<b>INSPECT NEUTRAL SWITCH CONNECTOR CIRCUIT FOR OPEN CIRCUIT</b> <ul style="list-style-type: none"> <li>• Disconnect neutral switch connector.</li> <li>• Turn ignition key to ON (engine OFF).</li> <li>• Depress clutch pedal and measure voltage between neutral switch terminal A (harness-side) and body ground.</li> <li>• Is voltage <b>below 1.0 V</b>?</li> </ul>	Yes	Go to next step.
		No	Repair or replace harness for open, then go to Step 9.
8	<b>INSPECT NEUTRAL SWITCH SIGNAL CIRCUIT FOR OPEN CIRCUIT</b> <ul style="list-style-type: none"> <li>• Turn ignition key to OFF.</li> <li>• Connect breakout box with PCM connector disconnected.</li> <li>• Turn ignition key to ON (engine OFF).</li> <li>• Depress clutch pedal and measure voltage between breakout box terminal 64 and body ground.</li> <li>• Is voltage <b>below 1.0 V</b>?</li> </ul>	Yes	Go to next step.
		No	Repair or replace harness for open, then go to Step 9.
9	<b>VERIFY TROUBLESHOOTING OF DTC P0705 COMPLETED</b> <ul style="list-style-type: none"> <li>• Make sure to reconnect all disconnected connectors.</li> <li>• Start engine.</li> <li>• Clear DTC from PCM memory using WDS or equivalent.</li> <li>• Drive vehicle <b>above 30 km/h {19 mph}</b> and stop vehicle.</li> <li>• Depress and release clutch pedal <b>more than 10 times</b> during drive cycle.</li> <li>• Is same DTC present?</li> </ul>	Yes	Replace PCM, then go to next step.
		No	Go to next step.
10	<b>VERIFY AFTER REPAIR PROCEDURE</b> <ul style="list-style-type: none"> <li>• Perform "After Repair Procedure". (See 01-02B-9 AFTER REPAIR PROCEDURE [FS].)</li> <li>• Is there any DTC present?</li> </ul>	Yes	Go to applicable DTC inspection. (See 01-02B-15 DTC TABLE [FS].)
		No	Troubleshooting completed.

01-02B

### DTC P1250 [FS]

A3U010201083W01

DTC P1250	Pressure regulator control (PRC) valve circuit malfunction
<b>DETECTION CONDITION</b>	<ul style="list-style-type: none"> <li>• PCM monitors input voltages from PRC solenoid valve. If voltage at PCM terminal 95 remains low or high, PCM determines that PRC solenoid valve circuit has malfunction.</li> </ul> <p><b>Diagnostic support note</b></p> <ul style="list-style-type: none"> <li>• This is a continuous monitor (CCM).</li> <li>• PCM detects the above malfunction condition in two consecutive drive cycles.</li> <li>• PENDING CODE is available if PCM detects the above malfunction condition during first drive cycle.</li> <li>• FREEZE FRAME DATA is available.</li> <li>• DTC is not stored in PCM memory.</li> </ul>

## ON-BOARD DIAGNOSTIC [ENGINE CONTROL SYSTEM (FS)]

<b>DTC P1250</b>	<b>Pressure regulator control (PRC) valve circuit malfunction</b>
<b>POSSIBLE CAUSE</b>	<ul style="list-style-type: none"> <li>PRC solenoid valve malfunction</li> <li>Connector or terminal malfunction</li> <li>Short to ground in wiring between PRC solenoid valve terminal B and PCM terminal 95</li> <li>Open circuit in wiring between main relay terminal D and PRC solenoid valve terminal A</li> <li>Open circuit in wiring between PRC solenoid valve terminal B and PCM terminal 95</li> <li>Short to power circuit between PRC solenoid valve terminal B and PCM terminal 95</li> <li>PCM malfunction</li> </ul>

### Diagnostic procedure

STEP	INSPECTION		ACTION
1	<b>VERIFY FREEZE FRAME DATA HAS BEEN RECORDED</b> <ul style="list-style-type: none"> <li>Has FREEZE FRAME DATA been recorded?</li> </ul>	Yes	Go to next step.
		No	Record FREEZE FRAME DATA on repair order, then go to next step.
2	<b>VERIFY RELATED REPAIR INFORMATION AVAILABILITY</b> <ul style="list-style-type: none"> <li>Check for related Service Bulletins availability.</li> <li>Is any related repair information available?</li> </ul>	Yes	Perform repair or diagnosis according to available repair information. <ul style="list-style-type: none"> <li>If vehicle is not repaired, go to next step.</li> </ul>
		No	Go to next step.
3	<b>CLASSIFY INTERMITTENT CONCERN OR CONTINUOUS CONCERN</b> <ul style="list-style-type: none"> <li>Clear DTC from memory using WDS or equivalent.</li> <li>Turn ignition key to OFF then Start engine.</li> <li>Is PENDING CODE of same DTC present?</li> </ul>	Yes	Go to next step.
		No	Refer to intermittent concern. (See 01-03B-4 INTERMITTENT CONCERN TROUBLESHOOTING [FS].)
4	<b>CLASSIFY OPEN CIRCUIT OR SHORT TO GROUND MALFUNCTION</b> <ul style="list-style-type: none"> <li>Disconnect PRC solenoid valve tube that connects to intake manifold.</li> <li>Connect vacuum pump to PRC solenoid valve.</li> <li>Apply vacuum and wait <b>5 seconds</b>.</li> <li>Is vacuum maintained?</li> </ul>	Yes	Go to Step 6.
		No	Go to next step.
5	<b>INSPECT PASSAGE CONTROL OF PRC SOLENOID VALVE</b> <ul style="list-style-type: none"> <li>Turn ignition key to OFF.</li> <li>Disconnect PRC solenoid valve connector.</li> <li>Is vacuum maintained?</li> </ul>	Yes	Repair or replace harness between PCM terminal 95 and PRC solenoid valve terminal B for short to ground, then go to Step 11.
		No	Replace PRC solenoid valve, then go to Step 11.



## ON-BOARD DIAGNOSTIC [ENGINE CONTROL SYSTEM (FS)]

STEP	INSPECTION	ACTION
6	<b>INSPECT PRC SOLENOID VALVE CONNECTOR FOR POOR CONNECTION</b> <ul style="list-style-type: none"> <li>Turn ignition key to OFF.</li> <li>Check for poor connection (damaged/pulled-out pins, corrosion, etc.).</li> <li>Is there malfunction?</li> </ul>	Yes Repair or replace terminal, then go to Step 11.
		No Go to next step.
7	<b>INSPECT PRC SOLENOID VALVE</b> <ul style="list-style-type: none"> <li>Measure resistance between PRC solenoid valve terminals (part-side).</li> <li>Is resistance <b>within 22—26 ohms</b>?</li> </ul>	Yes Go to next step.
		No Replace PRC solenoid valve, then go to Step 11.
8	<b>INSPECT PRC SOLENOID VALVE POWER SUPPLY CIRCUIT FOR OPEN CIRCUIT</b> <ul style="list-style-type: none"> <li>Turn ignition key to ON (Engine OFF).</li> <li>Measure voltage between PRC solenoid valve terminal A (harness-side) and body ground.</li> <li>Is voltage <b>B+</b>?</li> </ul>	Yes Go to next step.
		No Repair or replace harness for open, then go to Step 11.
9	<b>INSPECT PCM CONNECTOR FOR POOR CONNECTION</b> <ul style="list-style-type: none"> <li>Turn ignition key to OFF.</li> <li>Disconnect PCM connector.</li> <li>Check for poor connection at terminal 95 (damaged/pulled-out pins, corrosion, etc.).</li> <li>Is there malfunction?</li> </ul>	Yes Repair terminal, then go to Step 11.
		No Go to next step.
10	<b>INSPECT PRC SOLENOID VALVE CONTROL CIRCUIT</b> <ul style="list-style-type: none"> <li>Connect breakout box with PCM disconnected.</li> <li>Turn ignition key to ON (Engine OFF).</li> <li>Measure voltage between PRC solenoid valve terminal B (harness-side) and body ground.</li> <li>Is voltage <b>B+</b>?</li> </ul>	Yes Repair or replace harness for short to power, then go to next step.
		No Check for continuity between PRC solenoid valve terminal B (harness-side) and breakout box terminal 95. <ul style="list-style-type: none"> <li>If there is continuity, go to next step.</li> <li>If there is no continuity, repair or replace harness for open, then go to next step.</li> </ul>
11	<b>VERIFY TROUBLESHOOTING OF DTC P1250 COMPLETED</b> <ul style="list-style-type: none"> <li>Make sure to reconnect all disconnected connectors.</li> <li>Clear DTC from memory using WDS or equivalent.</li> <li>Turn ignition key to OFF then start engine.</li> <li>Is PENDING CODE of same DTC present?</li> </ul>	Yes Replace PCM, then go to next step.
		No Go to next step.
12	<b>VERIFY AFTER REPAIR PROCEDURE</b> <ul style="list-style-type: none"> <li>Perform "After Repair Procedure". (See 01-02B-9 AFTER REPAIR PROCEDURE [FS].)</li> <li>Is there any DTC present?</li> </ul>	Yes Go to applicable DTC inspection. (See 01-02B-15 DTC TABLE [FS].)
		No Troubleshooting completed.

01-02B

### DTC P1449 [FS]

A3U010201083W02

DTC P1449	Canister drain cut valve (CDCV) circuit malfunction
<b>DETECTION CONDITION</b>	<ul style="list-style-type: none"> <li>PCM monitors the input voltages from CDCV just after turning the ignition key to ON. If voltage at PCM terminal 18 remains low or high, PCM determines that CDCV circuit has malfunction.</li> </ul> <b>Diagnostic support note</b> <ul style="list-style-type: none"> <li>This is a diagnostic support DTC (monitored one per key cycle).</li> <li>MIL does not illuminate.</li> <li>FREEZE FRAME DATA is not available.</li> <li>DTC is not stored in PCM memory.</li> </ul>
<b>POSSIBLE CAUSE</b>	<ul style="list-style-type: none"> <li>CDCV malfunction</li> <li>Connector or terminal malfunction</li> <li>Short to ground in wiring between CDCV terminal B and PCM terminal 18</li> <li>Open circuit in wiring between main relay terminal D and CDCV terminal A</li> <li>Open circuit in wiring between CDCV terminal B and PCM terminal 18</li> <li>Short to power circuit between CDCV terminal B and PCM terminal 18</li> <li>PCM malfunction</li> </ul>

# ON-BOARD DIAGNOSTIC [ENGINE CONTROL SYSTEM (FS)]

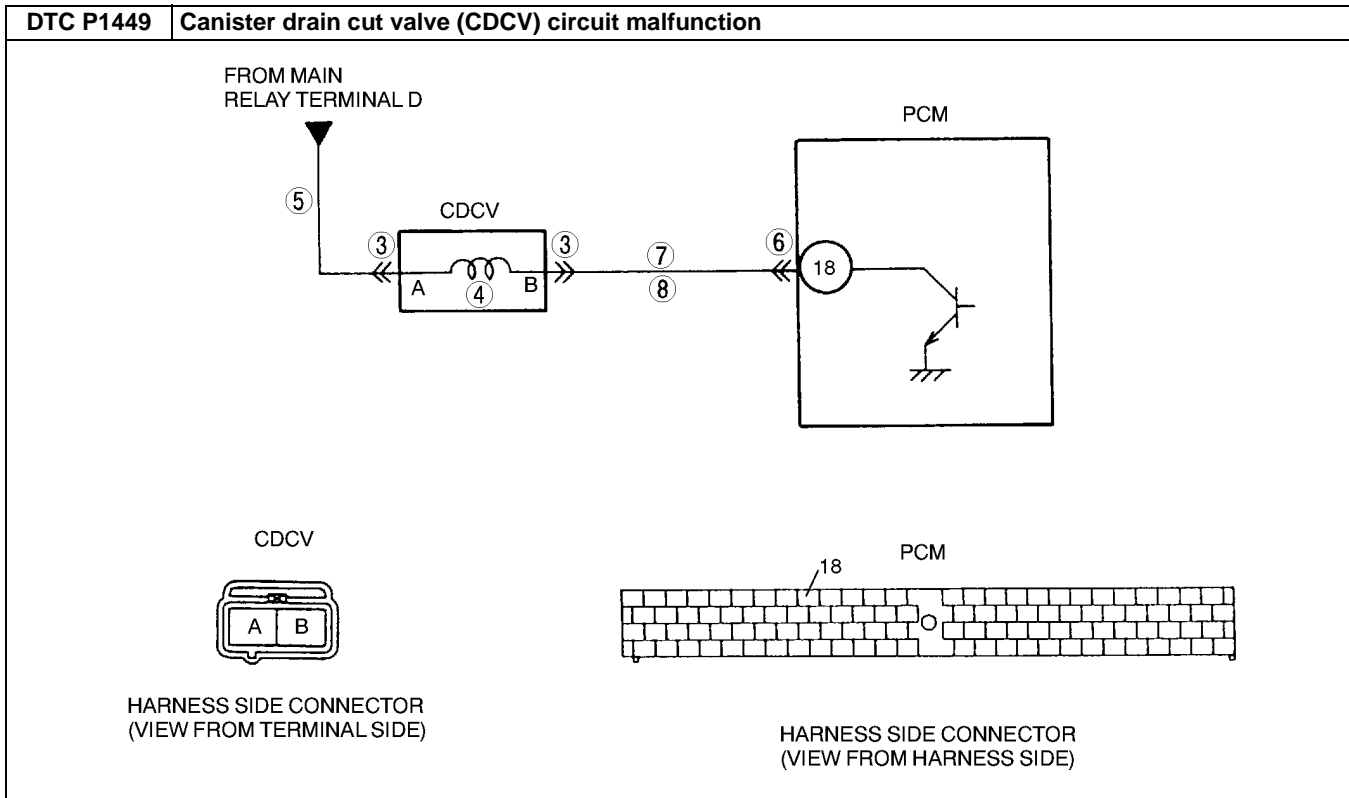

### Diagnostic procedure

STEP	INSPECTION		ACTION
1	<b>VERIFY RELATED REPAIR INFORMATION AVAILABILITY</b> <ul style="list-style-type: none"> <li>Check for related Service Bulletins availability.</li> <li>Is any related repair information available?</li> </ul>	Yes	Perform repair or diagnosis according to available repair information. <ul style="list-style-type: none"> <li>If vehicle is not repaired, go to next step.</li> </ul>
		No	Go to next step.
2	<b>CLASSIFY INTERMITTENT CONCERN OR CONTINUOUS CONCERN</b> <ul style="list-style-type: none"> <li>Turn ignition key to OFF then ON (Engine OFF).</li> <li>Is same DTC present?</li> </ul>	Yes	Go to next step.
		No	Refer to intermittent concern. (See 01-03B-4 INTERMITTENT CONCERN TROUBLESHOOTING [FS].)
3	<b>INSPECT CDCV CONNECTOR FOR POOR CONNECTION</b> <ul style="list-style-type: none"> <li>Turn ignition key to OFF.</li> <li>Check for poor connection (damaged/pulled-out pins, corrosion, etc.).</li> <li>Is there malfunction?</li> </ul>	Yes	Repair or replace terminal, then go to Step 9.
		No	Go to next step.
4	<b>INSPECT CDCV</b> <ul style="list-style-type: none"> <li>Measure resistance between CDCV terminals (part-side).</li> <li>Is resistance <b>within 17—21 ohms</b>?</li> </ul>	Yes	Go to next step.
		No	Replace CDCV, then go to Step 9.
5	<b>INSPECT CDCV POWER SUPPLY CIRCUIT FOR OPEN CIRCUIT</b> <ul style="list-style-type: none"> <li>Turn ignition key to ON (Engine OFF).</li> <li>Measure voltage between CDCV terminal A (harness-side) and body ground.</li> <li>Is voltage <b>B+</b>?</li> </ul>	Yes	Go to next step.
		No	Repair or replace harness for open, then go to Step 9.
6	<b>INSPECT PCM CONNECTOR FOR POOR CONNECTION</b> <ul style="list-style-type: none"> <li>Turn ignition key to OFF.</li> <li>Disconnect PCM connector.</li> <li>Check for poor connection at terminal 18. (damaged/pulled-out pins, corrosion, etc.).</li> <li>Is there malfunction?</li> </ul>	Yes	Repair terminal, then go to Step 9.
		No	Go to next step.

## ON-BOARD DIAGNOSTIC [ENGINE CONTROL SYSTEM (FS)]

STEP	INSPECTION	ACTION	
7	<b>INSPECT CDCV CONTROL CIRCUIT FOR SHORT TO GROUND</b> <ul style="list-style-type: none"> <li>Disconnect PCM connector.</li> <li>Check for continuity between CDCV terminal B (harness-side) and body ground.</li> <li>Is there continuity?</li> </ul>	Yes	Repair or replace harness for short to ground, then go to Step 9.
		No	Go to next step.
8	<b>INSPECT CDCV CONTROL CIRCUIT FOR SHORT TO POWER</b> <ul style="list-style-type: none"> <li>Connect breakout box with PCM disconnected.</li> <li>Turn ignition key to ON (Engine OFF).</li> <li>Measure voltage between CDCV terminal B (harness-side) and body ground.</li> <li>Is the voltage <b>B+</b>?</li> </ul>	Yes	Repair or replace harness for short to power, then go to next step.
		No	Check for continuity between CDCV terminal B (harness-side) and breakout box terminal 18. <ul style="list-style-type: none"> <li>If there is continuity, go to next step.</li> <li>If there is no continuity, repair or replace harness for open, then go to next step.</li> </ul>
9	<b>VERIFY TROUBLESHOOTING OF DTC P1449 COMPLETED</b> <ul style="list-style-type: none"> <li>Make sure to reconnect all disconnected connectors.</li> <li>Turn ignition key to OFF then ON (Engine OFF).</li> <li>Is same DTC present?</li> </ul>	Yes	Replace PCM, then go to next step.
		No	Go to next step.
10	<b>VERIFY AFTER REPAIR PROCEDURE</b> <ul style="list-style-type: none"> <li>Perform "After Repair Procedure". (See 01-02B-9 AFTER REPAIR PROCEDURE [FS].)</li> <li>Is there any DTC present?</li> </ul>	Yes	Go to applicable DTC inspection. (See 01-02B-15 DTC TABLE [FS].)
		No	Troubleshooting completed.

01-02B

### DTC P1450 [FS]

A3U010201083W03

DTC P1450	Evaporative emission control system malfunction (excessive vacuum)
<b>DETECTION CONDITION</b>	<ul style="list-style-type: none"> <li>PCM monitors fuel tank pressure signal when monitoring conditions are met. If vacuum is <b>above -3.92 kPa {-29.4 mmHg, -1.16 inHg}</b> for <b>10 seconds</b>, PCM determines the excessive vacuum.</li> </ul> <p><b>MONITORING CONDITIONS</b></p> <ul style="list-style-type: none"> <li>Intake air temperature is <b>above -10 °C {14 °F}</b>.</li> <li>Engine coolant temperature is <b>100 °C {212 °F} or below</b>.</li> <li>Vehicle speed is <b>99.8 km/h {61.9 mph} or below</b>.</li> <li>Engine coolant temperature at engine start is <b>below 35 °C {95 °F}</b>.</li> </ul> <p><b>Diagnostic support note</b></p> <ul style="list-style-type: none"> <li>This is a continuous monitor (CCM).</li> <li>MIL illuminates if PCM detects the above malfunction condition in two consecutive drive cycles.</li> <li>PENDING CODE is available if PCM detects the above malfunction condition during first drive cycle.</li> <li>FREEZE FRAME DATA is available.</li> <li>DTC is stored in PCM memory.</li> </ul>
<b>POSSIBLE CAUSE</b>	<ul style="list-style-type: none"> <li>CDCV malfunction</li> <li>Air filter clogged</li> <li>Charcoal canister malfunction</li> <li>Evaporative drain passage clogged (including check valve)</li> <li>Fuel tank pressure sensor malfunction</li> <li>Purge solenoid valve malfunction</li> </ul>

### Diagnostic procedure

STEP	INSPECTION	ACTION	
1	<b>VERIFY FREEZE FRAME DATA HAS BEEN RECORDED</b> <ul style="list-style-type: none"> <li>Has FREEZE FRAME DATA been recorded?</li> </ul>	Yes	Go to next step.
		No	Record FREEZE FRAME DATA on repair order, then go to next step.
2	<b>VERIFY RELATED REPAIR INFORMATION AVAILABILITY</b> <ul style="list-style-type: none"> <li>Check for related Service Bulletins availability.</li> <li>Is any related repair information available?</li> </ul>	Yes	Perform repair or diagnosis according to available repair information. <ul style="list-style-type: none"> <li>If vehicle is not repaired, go to next step.</li> </ul>
		No	Go to next step.
3	<b>VERIFY RELATED STORED DTCS</b> <ul style="list-style-type: none"> <li>Turn ignition key to OFF then start engine.</li> <li>Verify stored DTC.</li> <li>Are DTCs P0443 and/or P1449 present?</li> </ul>	Yes	Go to appropriate DTC inspection.
		No	Go to next step.

## ON-BOARD DIAGNOSTIC [ENGINE CONTROL SYSTEM (FS)]

STEP	INSPECTION	ACTION	
4	<b>INSPECT FOR OPERATION SOUND OF CDCV</b> <ul style="list-style-type: none"> <li>• Perform CDCV inspection. (See 01-16-10 CANISTER DRAIN CUT VALVE (CDCV) INSPECTION.)</li> <li>• Is CDCV okay?</li> </ul>	Yes	Go to next step.
		No	Replace it if necessary, then go to Step 9.
5	<b>INSPECT PURGE SOLENOID VALVE</b> <ul style="list-style-type: none"> <li>• Disconnect vacuum hose that connects to intake manifold from purge solenoid valve.</li> <li>• Connect vacuum pump to purge solenoid valve.</li> <li>• Pump vacuum several times and wait a <b>few seconds</b>.</li> <li>• Does vacuum hold?</li> </ul>	Yes	Disconnect vacuum pump and connect vacuum hose to purge solenoid valve. Go to next step.
		No	Inspect purge solenoid valve and related harness. Replace it if necessary, then go to Step 9.
6	<b>INSPECT CHARCOAL CANISTER FOR CLOGGING</b> <ul style="list-style-type: none"> <li>• Remove charcoal canister and inspect for clogging. (See 01-16-9 CHARCOAL CANISTER INSPECTION.)</li> <li>• Is it okay?</li> </ul>	Yes	Go to next step.
		No	Replace charcoal canister, then go to Step 9.
7	<b>INSPECT FUEL TANK PRESSURE SENSOR</b> <ul style="list-style-type: none"> <li>• Inspect fuel tank pressure sensor. (See 01-40B-40 FUEL TANK PRESSURE SENSOR INSPECTION [FS].)</li> <li>• Is it okay?</li> </ul>	Yes	Go to next step.
		No	Replace fuel tank pressure sensor, then go to Step 9.
8	<b>INSPECT AIR FILTER FOR CLOGGING</b> <ul style="list-style-type: none"> <li>• Remove and inspect air filter connected to CDCV for clogging.</li> <li>• Is it okay?</li> </ul>	Yes	Inspect for clogging in following area: <ul style="list-style-type: none"> <li>• From charcoal canister to CDCV</li> <li>• Drain passage including check valve — Repair or replace faulty area, then go to next step.</li> </ul>
		No	Repair or replace air filter, then go to next step.
9	<b>VERIFY MONITORING CONDITION FOR EVAPORATIVE SYSTEM TEST</b> <ul style="list-style-type: none"> <li>• Make sure to reconnect all disconnected connectors.</li> <li>• Turn ignition key to ON (Engine OFF).</li> <li>• Clear DTC from memory using WDS or equivalent.</li> <li>• Verify that following conditions are met. <ul style="list-style-type: none"> <li>— BARO: <b>69.7 kPa {523 mmHg, 20.5 inHg} or higher</b></li> <li>— ECT: <b>-10.0—20.0 °C {14.0—68.0 °F}</b> [at barometric pressure <b>69.7 kPa {523 mmHg, 20.5 inHg}</b>]</li> <li>— IAT: <b>-10—55 °C {50—131 °F}</b></li> <li>— Fuel tank level: <b>15—85%</b></li> </ul> </li> <li>• Is there any condition out of specification?</li> </ul>	Yes	Take corrective action (e.g. cool down engine), then repeat this step. <p style="text-align: center;"><b>Note</b></p> <ul style="list-style-type: none"> <li>• Readings need to be in the indicated ranges to perform Drive Mode 4.</li> </ul>
		No	Go to next step.
10	<b>MONITOR EVAP SYSTEM BY DRIVE MODE 4</b> <ul style="list-style-type: none"> <li>• Run Drive Mode 4. (See 01-02B-12 Mode 4 (EVAP system repair verification drive mode).)</li> <li>• Stop vehicle and access ON BOARD SYSTEM READINESS TESTS to inspect Drive Mode completion status.</li> <li>• Has EVAPORATIVE PURGE SYSTEM been monitored?</li> </ul>	Yes	Go to next step.
		No	Go back to Step 9.
11	<b>VERIFY TROUBLESHOOTING OF DTC P1450 COMPLETED</b> <ul style="list-style-type: none"> <li>• Is pending code of same DTC present?</li> </ul>	Yes	Replace PCM, then go to next step.
		No	Go to next step.
12	<b>VERIFY AFTER REPAIR PROCEDURE</b> <ul style="list-style-type: none"> <li>• Perform “After Repair Procedure”. (See 01-02B-9 AFTER REPAIR PROCEDURE [FS].)</li> <li>• Is there any DTC present?</li> </ul>	Yes	Go to applicable DTC inspection. (See 01-02B-15 DTC TABLE [FS].)
		No	Troubleshooting completed.

# ON-BOARD DIAGNOSTIC [ENGINE CONTROL SYSTEM (FS)]

DTC P1487 [FS]

A3U010201083W04

01-02B

<b>DTC P1487</b>	<b>EGR boost sensor solenoid valve circuit malfunction</b>
<b>DETECTION CONDITION</b>	<ul style="list-style-type: none"> <li>PCM monitors input voltages from EGR boost sensor solenoid valve just after turning the ignition key to ON. If voltage at PCM terminal 98 remains low or high, PCM determines that EGR boost sensor solenoid valve circuit has malfunction.</li> </ul> <p><b>Diagnostic support note</b></p> <ul style="list-style-type: none"> <li>This is a diagnostic support DTC (monitored once per key cycle).</li> <li>MIL does not illuminate.</li> <li>FREEZE FRAME DATA is not available.</li> <li>DTC is not stored in PCM memory.</li> </ul>
<b>POSSIBLE CAUSE</b>	<ul style="list-style-type: none"> <li>EGR boost sensor solenoid valve malfunction</li> <li>Connector or terminal malfunction</li> <li>Short to ground in wiring between EGR boost sensor solenoid valve terminal B and PCM terminal 98</li> <li>Open circuit in wiring between main relay terminal D and EGR boost sensor solenoid valve terminal A</li> <li>Open circuit in wiring between EGR boost sensor solenoid valve terminal B and PCM terminal 98</li> <li>Short to power circuit between EGR boost sensor solenoid valve terminal B and PCM terminal 98</li> <li>PCM malfunction</li> </ul>

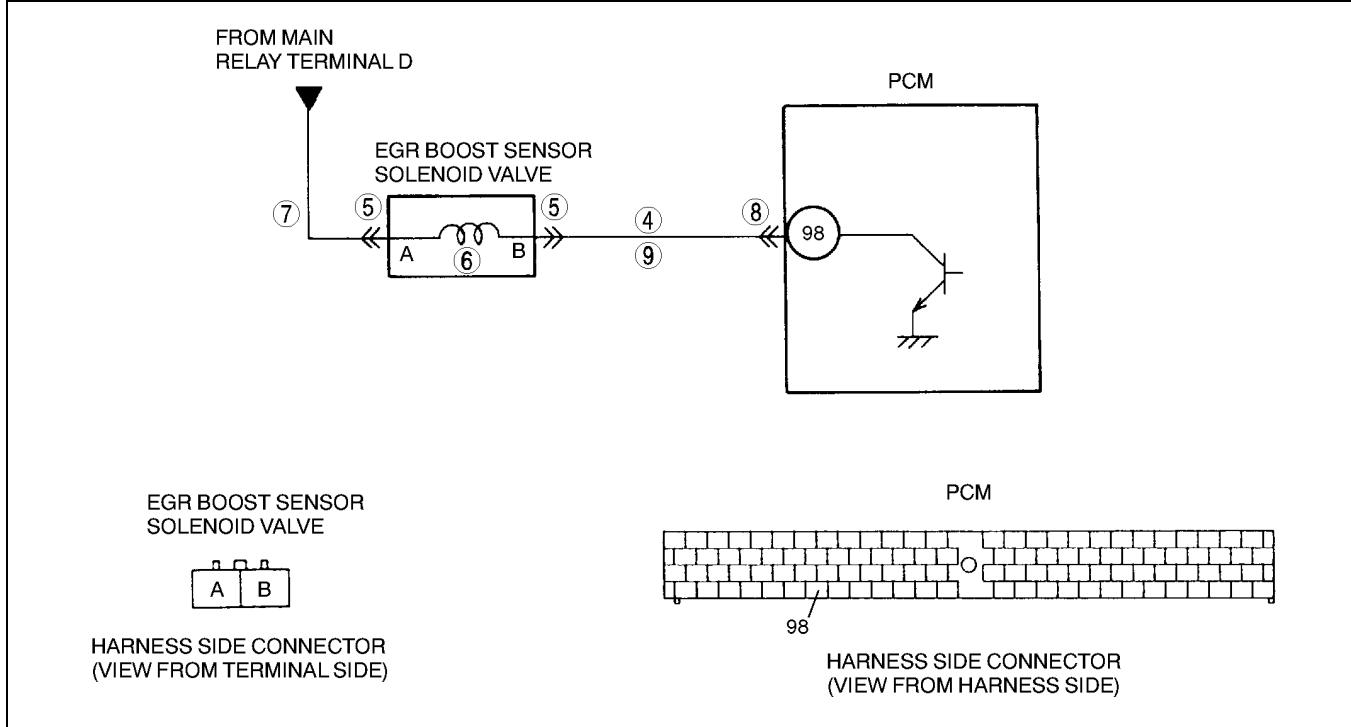

**Diagnostic procedure**

STEP	INSPECTION		ACTION
1	<b>VERIFY RELATED REPAIR INFORMATION AVAILABILITY</b> <ul style="list-style-type: none"> <li>Check for related Service Bulletins availability.</li> <li>Is any related repair information available?</li> </ul>	Yes	Perform repair or diagnosis according to available repair information. <ul style="list-style-type: none"> <li>If vehicle is not repaired, go to next step.</li> </ul>
		No	Go to next step.
2	<b>CLASSIFY INTERMITTENT CONCERN OR CONTINUOUS CONCERN</b> <ul style="list-style-type: none"> <li>Turn ignition key to OFF then ON (Engine OFF).</li> <li>Is same DTC present?</li> </ul>	Yes	Go to next step.
		No	Intermittent concern exists. Go to INTERMITTENT CONCERN TROUBLESHOOTING procedure. (See 01-03B-4 INTERMITTENT CONCERN TROUBLESHOOTING [FS].)
3	<b>CLASSIFY OPEN CIRCUIT OR SHORT TO GROUND MALFUNCTION</b> <ul style="list-style-type: none"> <li>Disconnect EGR boost sensor solenoid valve tube at solenoid side that connects to EGR valve.</li> <li>Connect vacuum pump to EGR boost solenoid valve.</li> <li>Apply vacuum.</li> <li>Wait for 5 seconds.</li> <li>Is vacuum maintained?</li> </ul>	Yes	Go to Step 5.
		No	Go to next step.

## ON-BOARD DIAGNOSTIC [ENGINE CONTROL SYSTEM (FS)]

STEP	INSPECTION	ACTION	
4	<b>INSPECT PASSAGE CONTROL OF EGR BOOST SENSOR SOLENOID VALVE</b> <ul style="list-style-type: none"> <li>• Turn ignition key to OFF.</li> <li>• Disconnect EGR boost sensor solenoid valve connector.</li> <li>• Apply vacuum and wait for <b>5 seconds</b>.</li> <li>• Is vacuum maintained?</li> </ul>	Yes	Repair or replace harness between solenoid valve terminal B and PCM terminal 98 for short to ground, then go to Step 10.
		No	Replace EGR boost sensor solenoid valve, then go to Step 10.
5	<b>INSPECT EGR BOOST SENSOR SOLENOID VALVE CONNECTOR FOR POOR CONNECTION</b> <ul style="list-style-type: none"> <li>• Turn ignition key to OFF.</li> <li>• Check for poor connection (damaged/pulled-out pins, corrosion, etc.).</li> <li>• Is there malfunction?</li> </ul>	Yes	Repair or replace terminal, then go to Step 10.
		No	Go to next step.
6	<b>INSPECT EGR BOOST SENSOR SOLENOID VALVE</b> <ul style="list-style-type: none"> <li>• Measure resistance between EGR boost sensor solenoid valve terminals (part-side).</li> <li>• Is resistance <b>within 22—26 ohms</b>?</li> </ul>	Yes	Go to next step.
		No	Replace EGR boost sensor solenoid valve, then go to Step 10.
7	<b>INSPECT EGR BOOST SENSOR SOLENOID VALVE POWER SUPPLY CIRCUIT FOR OPEN CIRCUIT</b> <ul style="list-style-type: none"> <li>• Turn ignition key to ON (Engine OFF).</li> <li>• Measure voltage between EGR boost sensor solenoid valve terminal A (harness-side) and body ground.</li> <li>• Is voltage <b>B+</b>?</li> </ul>	Yes	Go to next step.
		No	Repair or replace harness for open, then go to Step 10.
8	<b>INSPECT PCM CONNECTOR FOR POOR CONNECTION</b> <ul style="list-style-type: none"> <li>• Turn ignition key to OFF.</li> <li>• Disconnect PCM connector.</li> <li>• Check for poor connection at terminal 98. (damaged/pulled-out pins, corrosion, etc.).</li> <li>• Is there malfunction?</li> </ul>	Yes	Repair terminal, then go to Step 10.
		No	Go to next step.
9	<b>INSPECT EGR BOOST SENSOR SOLENOID VALVE CONTROL CIRCUIT</b> <ul style="list-style-type: none"> <li>• Connect breakout box with PCM disconnected.</li> <li>• Turn ignition key to ON (Engine OFF).</li> <li>• Measure voltage between breakout box terminal B (harness-side) and body ground.</li> <li>• Is voltage <b>B+</b>?</li> </ul>	Yes	Repair or replace harness for short to power, then go to next step.
		No	Check for continuity between EGR boost sensor solenoid valve terminal B (harness-side) and breakout box terminal 98. <ul style="list-style-type: none"> <li>• If there is continuity, go to next step.</li> <li>• If there is no continuity, repair or replace harness for open, then go to next step.</li> </ul>
10	<b>VERIFY TROUBLESHOOTING OF DTC P1487 COMPLETED</b> <ul style="list-style-type: none"> <li>• Make sure to reconnect all disconnected connectors.</li> <li>• Turn ignition key to OFF then ON (Engine OFF).</li> <li>• Is same DTC present?</li> </ul>	Yes	Replace PCM, then go to next step.
		No	Go to next step.
11	<b>VERIFY AFTER REPAIR PROCEDURE</b> <ul style="list-style-type: none"> <li>• Perform “After Repair Procedure”. (See 01–02B–9 AFTER REPAIR PROCEDURE [FS].)</li> <li>• Is there any DTC present?</li> </ul>	Yes	Go to applicable DTC inspection. (See 01–02B–15 DTC TABLE [FS].)
		No	Troubleshooting completed.

# ON-BOARD DIAGNOSTIC [ENGINE CONTROL SYSTEM (FS)]

DTC P1496 [FS]

A3U010201083W05

01-02B

<b>DTC P1496</b>	<b>EGR valve stepping motor coil 1 open or short</b>
<b>DETECTION CONDITION</b>	<ul style="list-style-type: none"> <li>PCM monitors input voltages from EGR valve coil control circuit just after turning ignition key to ON. If voltage at PCM terminal 68 remains low or high, PCM determines that EGR valve circuit has malfunction.</li> </ul> <p><b>Diagnostic support note</b></p> <ul style="list-style-type: none"> <li>This is a diagnostic support DTC (monitored once per key cycle)</li> <li>MIL does not illuminate.</li> <li>FREEZE FRAME DATA is not available.</li> <li>DTC is not stored in PCM memory.</li> </ul>
<b>POSSIBLE CAUSE</b>	<ul style="list-style-type: none"> <li>EGR valve malfunction</li> <li>Connector or terminal malfunction</li> <li>Short to ground circuit in wiring between EGR valve terminal E and PCM terminal 68</li> <li>Open circuit in wiring between EGR valve terminal E and PCM terminal 68</li> <li>Short to power circuit in wiring between EGR valve terminal E and PCM terminal 68</li> <li>Open circuit in wiring between main relay terminal D and EGR valve terminal C</li> <li>PCM malfunction</li> </ul>

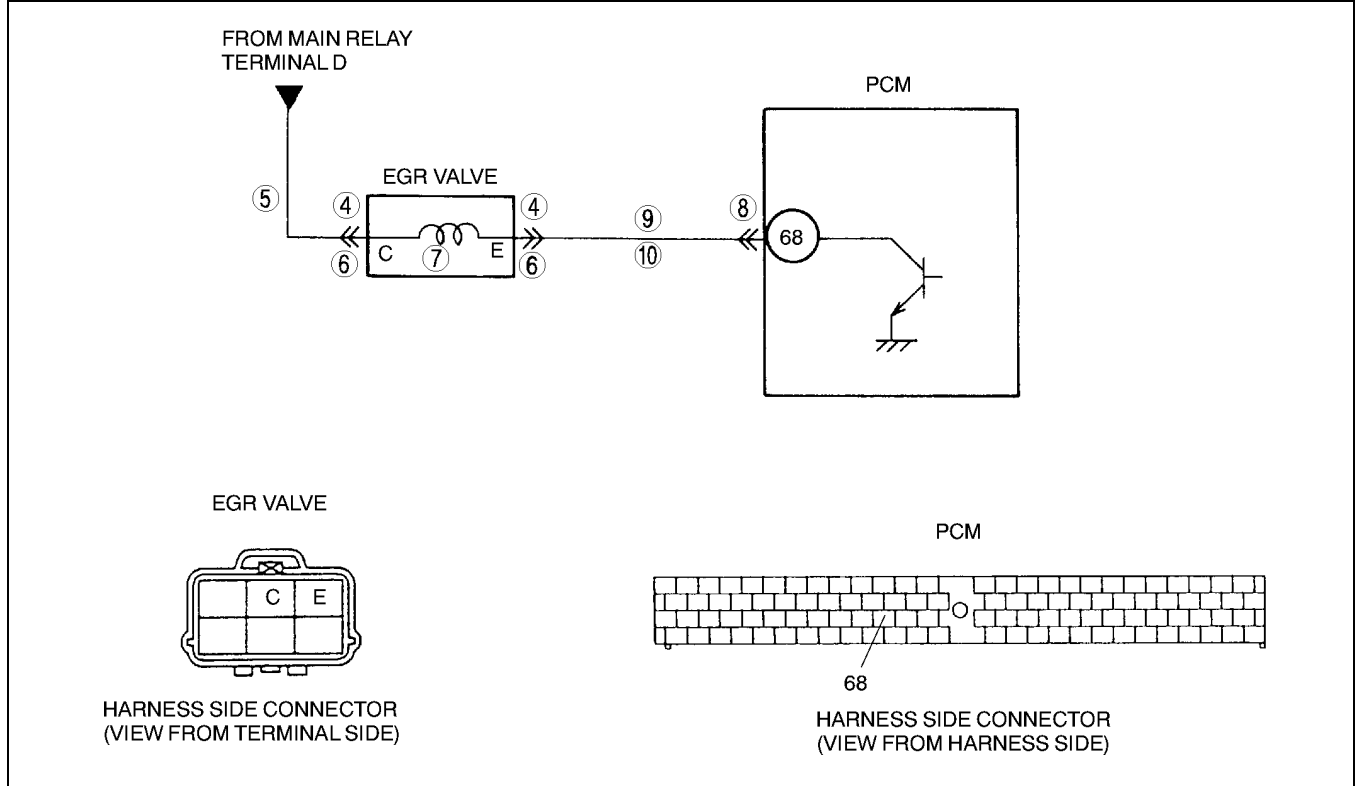

**Diagnostic procedure**

STEP	INSPECTION		ACTION
1	<b>VERIFY RELATED REPAIR INFORMATION AVAILABILITY</b> <ul style="list-style-type: none"> <li>Check for related Service Bulletins availability.</li> <li>Is any repair information available?</li> </ul>	Yes	Perform repair or diagnosis according to available repair information. <ul style="list-style-type: none"> <li>If vehicle is not repaired, go to next step.</li> </ul>
		No	Go to next step.
2	<b>CLASSIFY INTERMITTENT CONCERN OR CONTINUOUS CONCERN</b> <ul style="list-style-type: none"> <li>Turn ignition key to OFF then ON (Engine OFF).</li> <li>Is same DTC present?</li> </ul>	Yes	Go to next step.
		No	Refer to intermittent concern. (See 01-03B-4 INTERMITTENT CONCERN TROUBLESHOOTING [FS].)
3	<b>CLASSIFY POWER CIRCUIT OR CONTROL CIRCUIT MALFUNCTION</b> <ul style="list-style-type: none"> <li>Is same DTC and P1497 present?</li> </ul>	Yes	Malfunction at EGR valve or power circuit. Go to next step.
		No	Malfunction at EGR valve or control circuit. Go to Step 6.

## ON-BOARD DIAGNOSTIC [ENGINE CONTROL SYSTEM (FS)]

STEP	INSPECTION	ACTION	
4	<b>INSPECT EGR VALVE FOR POOR CONNECTION</b> <ul style="list-style-type: none"> <li>• Turn ignition key to OFF.</li> <li>• Disconnect EGR valve connector.</li> <li>• Check for poor connection (damaged/pulled-out terminals, corrosion, etc.).</li> <li>• Is there malfunction?</li> </ul>	Yes	Repair or replace terminals, then go to Step 11.
		No	Go to next step.
5	<b>INSPECT POWER CIRCUIT FOR OPEN CIRCUIT</b> <ul style="list-style-type: none"> <li>• Turn ignition key to ON (Engine OFF).</li> <li>• Measure voltage between EGR valve terminal C (harness-side) and body ground.</li> <li>• Is voltage <b>B+</b>?</li> </ul>	Yes	Inspect EGR valve coils 1 and 2. (See 01–16–15 EGR VALVE INSPECTION.) <ul style="list-style-type: none"> <li>• If there is a malfunction, replace EGR valve, and then go to Step 11.</li> <li>• If there is no malfunction, go to Step 11.</li> </ul>
		No	Repair or replace harness, then go to Step 11.
6	<b>INSPECT EGR VALVE FOR POOR CONNECTION</b> <ul style="list-style-type: none"> <li>• Turn ignition key to OFF.</li> <li>• Disconnect EGR valve connector.</li> <li>• Check for poor connection (damaged/pulled-out terminals, corrosion, etc.).</li> <li>• Is there malfunction?</li> </ul>	Yes	Repair or replace terminals, then go to Step 11.
		No	Go to next step.
7	<b>INSPECT EGR VALVE</b> <ul style="list-style-type: none"> <li>• Measure resistance between EGR valve terminals C and E (part-side).</li> <li>• Is resistance <b>within 20—24 ohms</b>?</li> </ul>	Yes	Go to next step.
		No	Replace EGR valve, then go to Step 11.
8	<b>INSPECT PCM CONNECTOR FOR POOR CONNECTION</b> <ul style="list-style-type: none"> <li>• Disconnect PCM connector.</li> <li>• Check for poor connection at terminal 68 (damaged/pulled-out terminals, corrosion, etc.).</li> <li>• Is there malfunction?</li> </ul>	Yes	Repair terminal, then go to Step 11.
		No	Go to next step.
9	<b>INSPECT CONTROL CIRCUIT FOR SHORT</b> <ul style="list-style-type: none"> <li>• Check continuity between EGR valve terminal E (harness-side) and body ground.</li> <li>• Is there continuity?</li> </ul>	Yes	Repair or replace harness for short to ground, then go to Step 11.
		No	Measure voltage between EGR valve terminal E and body ground. <ul style="list-style-type: none"> <li>• If voltage is <b>B+</b>, repair or replace harness for short to power, then go to next step.</li> <li>• If voltage is <b>approx. 0 V</b>, go to next step.</li> </ul>
10	<b>INSPECT CONTROL CIRCUIT FOR OPEN CIRCUIT</b> <ul style="list-style-type: none"> <li>• Connect breakout box with PCM disconnected.</li> <li>• Check for continuity between EGR valve terminal E (harness-side) and breakout box terminal 68.</li> <li>• Is there continuity?</li> </ul>	Yes	Go to next step.
		No	Repair or replace harness for open, then go to next step.
11	<b>VERIFY TROUBLESHOOTING OF DTC P1496 COMPLETED</b> <ul style="list-style-type: none"> <li>• Make sure to reconnect all disconnected connectors.</li> <li>• Turn ignition key to OFF then ON (Engine OFF).</li> <li>• Is same DTC present?</li> </ul>	Yes	Replace PCM, then go to next step.
		No	Go to next step.
12	<b>VERIFY AFTER REPAIR PROCEDURE</b> <ul style="list-style-type: none"> <li>• Perform “After Repair Procedure”. (See 01–02B–9 AFTER REPAIR PROCEDURE [FS].)</li> <li>• Is there any DTC present?</li> </ul>	Yes	Go to applicable DTC inspection. (See 01–02B–15 DTC TABLE [FS].)
		No	Troubleshooting completed.



# ON-BOARD DIAGNOSTIC [ENGINE CONTROL SYSTEM (FS)]

DTC P1497 [FS]

A3U010201083W06

01-02B

<b>DTC P1497</b>	<b>EGR valve stepping motor coil 2 open or short circuit</b>
<b>DETECTION CONDITION</b>	<ul style="list-style-type: none"> <li>PCM monitors input voltages from EGR valve coil control circuit just after turning ignition key to ON. If voltage at PCM terminal 72 remains low or high, PCM determines that EGR valve circuit has malfunction.</li> </ul> <p><b>Diagnostic support note</b></p> <ul style="list-style-type: none"> <li>This is a diagnostic support DTC (monitored once per key cycle).</li> <li>MIL does not illuminate.</li> <li>FREEZE FRAME DATA is not available.</li> <li>DTC is not stored in PCM memory.</li> </ul>
<b>POSSIBLE CAUSE</b>	<ul style="list-style-type: none"> <li>EGR valve malfunction</li> <li>Connector or terminal malfunction</li> <li>Short to ground circuit in wiring between EGR valve terminal A and PCM terminal 72</li> <li>Open circuit in wiring between EGR valve terminal A and PCM terminal 72</li> <li>Short to power circuit in wiring between EGR valve terminal A and PCM terminal 72</li> <li>Open circuit in wiring between main relay terminal D and EGR valve terminal C</li> <li>PCM malfunction</li> </ul>

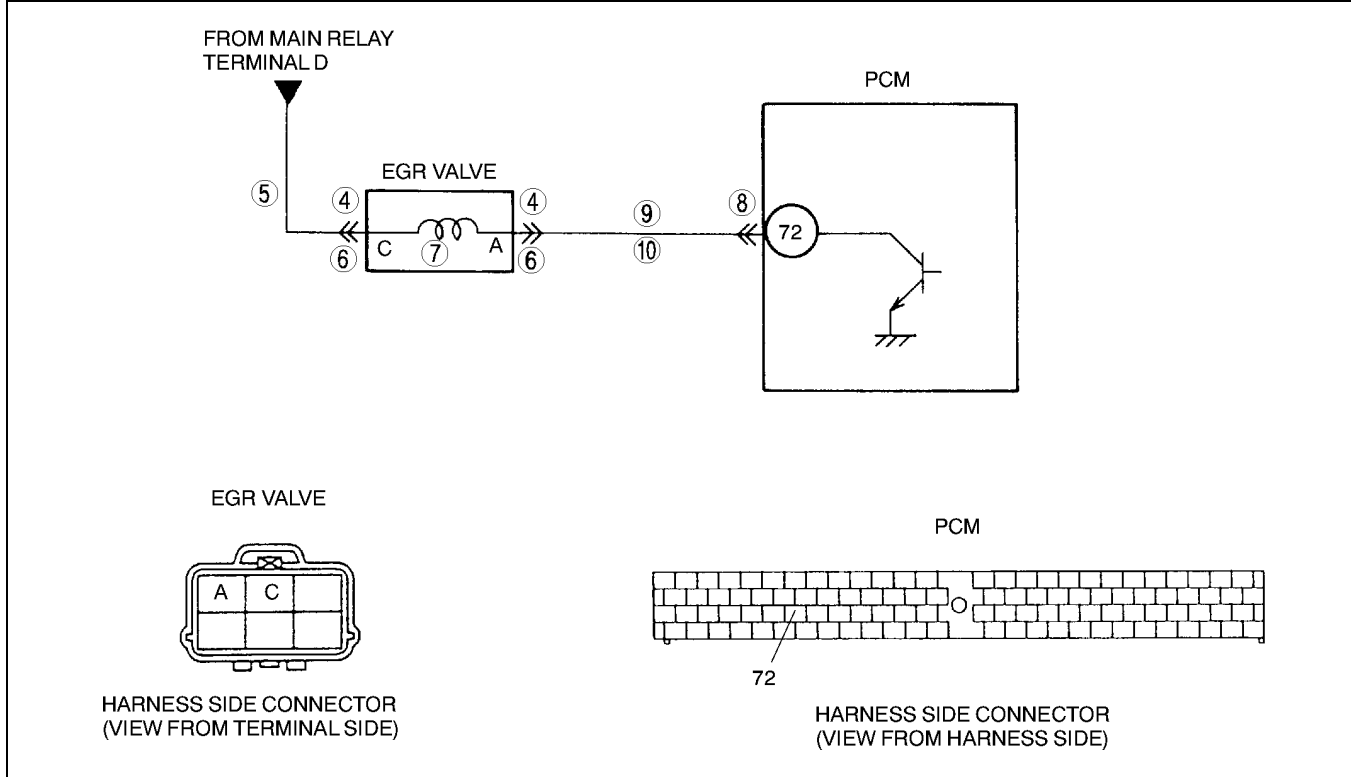

**Diagnostic procedure**

STEP	INSPECTION		ACTION
1	<b>VERIFY RELATED REPAIR INFORMATION AVAILABILITY</b> <ul style="list-style-type: none"> <li>Check for related Service Bulletins availability.</li> <li>Is any repair information available?</li> </ul>	Yes	Perform repair or diagnosis according to available repair information. <ul style="list-style-type: none"> <li>If vehicle is not repaired, go to next step.</li> </ul>
		No	Go to next step.
2	<b>CLASSIFY INTERMITTENT CONCERN OR CONTINUOUS CONCERN</b> <ul style="list-style-type: none"> <li>Turn ignition key to OFF then ON (Engine OFF).</li> <li>Is same DTC present?</li> </ul>	Yes	Go to next step.
		No	Refer to intermittent concern. (See 01-03B-4 INTERMITTENT CONCERN TROUBLESHOOTING [FS].)
3	<b>CLASSIFY POWER CIRCUIT OR CONTROL CIRCUIT MALFUNCTION</b> <ul style="list-style-type: none"> <li>Is same DTC and P1496 present?</li> </ul>	Yes	Malfunction at EGR valve or power circuit. Go to next step.
		No	Malfunction at EGR valve or control circuit. Go to Step 6.

## ON-BOARD DIAGNOSTIC [ENGINE CONTROL SYSTEM (FS)]

STEP	INSPECTION	ACTION	
4	<b>INSPECT EGR VALVE FOR POOR CONNECTION</b> <ul style="list-style-type: none"> <li>• Turn ignition key to OFF.</li> <li>• Disconnect EGR valve connector.</li> <li>• Check for poor connection (damaged/pulled-out terminals, corrosion, etc.).</li> <li>• Is there malfunction?</li> </ul>	Yes	Repair or replace terminals, then go to Step 11.
		No	Go to next step.
5	<b>INSPECT POWER CIRCUIT FOR OPEN CIRCUIT</b> <ul style="list-style-type: none"> <li>• Turn ignition key to ON (Engine OFF).</li> <li>• Measure voltage between EGR valve terminal C (harness-side) and body ground.</li> <li>• Is voltage <b>B+</b>?</li> </ul>	Yes	Inspect EGR valve coils 1 and 2. (See 01–16–15 EGR VALVE INSPECTION.) <ul style="list-style-type: none"> <li>• If there is a malfunction, replace EGR valve, and then go to Step 11.</li> <li>• If there is no malfunction, then go to Step 11.</li> </ul>
		No	Repair or replace harness for open circuit, then go to Step 11.
6	<b>INSPECT EGR VALVE FOR POOR CONNECTION</b> <ul style="list-style-type: none"> <li>• Turn ignition key to OFF.</li> <li>• Disconnect EGR valve connector.</li> <li>• Check for poor connection (damaged/pulled-out terminals, corrosion, etc.).</li> <li>• Is there malfunction?</li> </ul>	Yes	Repair or replace terminals, then go to Step 11.
		No	Go to next step.
7	<b>INSPECT EGR VALVE</b> <ul style="list-style-type: none"> <li>• Measure resistance between EGR valve terminals C and A (part-side).</li> <li>• Is resistance <b>within 20—24 ohms</b>?</li> </ul>	Yes	Go to next step.
		No	Replace EGR valve, then go to Step 11.
8	<b>INSPECT PCM CONNECTOR FOR POOR CONNECTION</b> <ul style="list-style-type: none"> <li>• Disconnect PCM connector.</li> <li>• Check for poor connection at terminal 72 (damaged/pulled-out terminals, corrosion, etc.).</li> <li>• Is there malfunction?</li> </ul>	Yes	Repair terminal, then go to Step 11.
		No	Go to next step.
9	<b>INSPECT CONTROL CIRCUIT FOR SHORT</b> <ul style="list-style-type: none"> <li>• Check continuity between EGR valve terminal A (harness-side) and body ground.</li> <li>• Is there continuity?</li> </ul>	Yes	Repair or replace harness for short to ground, then go to Step 11.
		No	Measure voltage between EGR valve terminal A and body ground. <ul style="list-style-type: none"> <li>• If voltage is <b>B+</b>, repair or replace harness for short to power, then go to next step.</li> <li>• If voltage is <b>approx. 0 V</b>, go to next step.</li> </ul>
10	<b>INSPECT CONTROL CIRCUIT FOR OPEN CIRCUIT</b> <ul style="list-style-type: none"> <li>• Connect breakout box with PCM disconnected.</li> <li>• Check for continuity between EGR valve terminal A (harness-side) and breakout box terminal 72.</li> <li>• Is there continuity?</li> </ul>	Yes	Go to next step.
		No	Repair or replace harness for open, then go to next step.
11	<b>VERIFY TROUBLESHOOTING OF DTC P1497 COMPLETED</b> <ul style="list-style-type: none"> <li>• Make sure to reconnect all disconnected connectors.</li> <li>• Turn ignition key to OFF, then ON (Engine OFF).</li> <li>• Is same DTC present?</li> </ul>	Yes	Replace PCM, then go to next step.
		No	Go to next step.
12	<b>VERIFY AFTER REPAIR PROCEDURE</b> <ul style="list-style-type: none"> <li>• Perform “After Repair Procedure”. (See 01–02B–9 AFTER REPAIR PROCEDURE [FS].)</li> <li>• Is there any DTC present?</li> </ul>	Yes	Go to applicable DTC inspection. (See 01–02B–15 DTC TABLE [FS].)
		No	Troubleshooting completed.

# ON-BOARD DIAGNOSTIC [ENGINE CONTROL SYSTEM (FS)]

DTC P1498 [FS]

A3U010201083W07

01-02B

<b>DTC P1498</b>	<b>EGR valve stepping motor coil 3 open or short circuit</b>
<b>DETECTION CONDITION</b>	<ul style="list-style-type: none"> <li>PCM monitors input voltages from EGR valve coil control circuit just after turning ignition key to ON. If voltage at PCM terminal 46 remains low or high, PCM determines that EGR valve circuit has malfunction.</li> </ul> <p><b>Diagnostic support note</b></p> <ul style="list-style-type: none"> <li>This is a diagnostic support DTC (monitored once per key cycle).</li> <li>MIL does not illuminate.</li> <li>FREEZE FRAME DATA is not available.</li> <li>DTC is not stored in PCM memory.</li> </ul>
<b>POSSIBLE CAUSE</b>	<ul style="list-style-type: none"> <li>EGR valve malfunction</li> <li>Connector or terminal malfunction</li> <li>Short to ground circuit in wiring between EGR valve terminal B and PCM terminal 46</li> <li>Open circuit in wiring between EGR valve terminal B and PCM terminal 46</li> <li>Short to power circuit in wiring between EGR valve terminal B and PCM terminal 46</li> <li>Open circuit in wiring between main relay terminal D and EGR valve terminal D</li> <li>PCM malfunction</li> </ul>

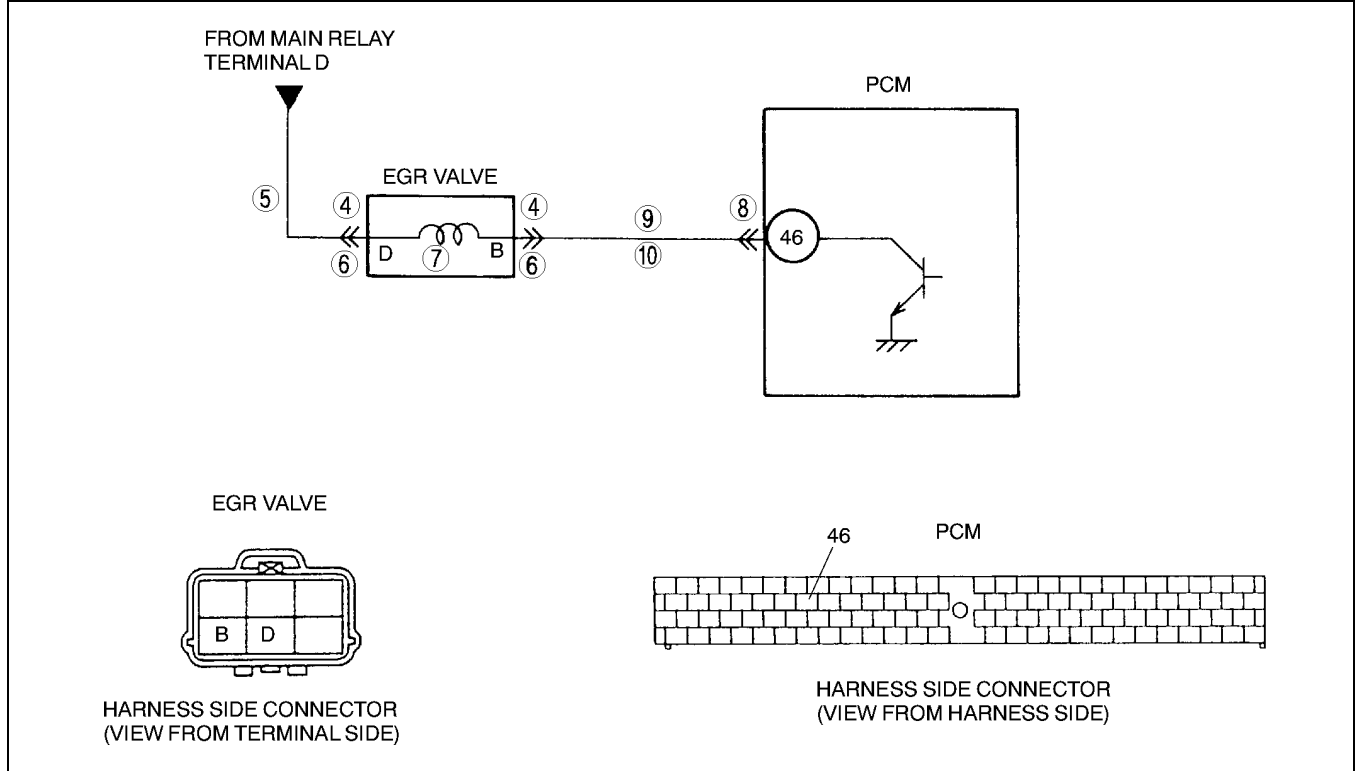

**Diagnostic procedure**

STEP	INSPECTION		ACTION
1	<b>VERIFY RELATED REPAIR INFORMATION AVAILABILITY</b> <ul style="list-style-type: none"> <li>Check for related Service Bulletins availability.</li> <li>Is any repair information available?</li> </ul>	Yes	Perform repair or diagnosis according to available repair information. <ul style="list-style-type: none"> <li>If vehicle is not repaired, go to next step.</li> </ul>
		No	Go to next step.
2	<b>CLASSIFY INTERMITTENT CONCERN OR CONTINUOUS CONCERN</b> <ul style="list-style-type: none"> <li>Turn ignition key to OFF then ON (Engine OFF).</li> <li>Is same DTC present?</li> </ul>	Yes	Go to next step.
		No	Refer to intermittent concern. (See 01-03B-4 INTERMITTENT CONCERN TROUBLESHOOTING [FS].)
3	<b>CLASSIFY POWER CIRCUIT OR CONTROL CIRCUIT MALFUNCTION</b> <ul style="list-style-type: none"> <li>Is same DTC and P1499 present?</li> </ul>	Yes	Malfunction at EGR valve or power circuit. Go to next step.
		No	Malfunction at EGR valve or control circuit. Go to Step 6.

## ON-BOARD DIAGNOSTIC [ENGINE CONTROL SYSTEM (FS)]

STEP	INSPECTION	ACTION	
4	<b>INSPECT EGR VALVE FOR POOR CONNECTION</b> <ul style="list-style-type: none"> <li>• Turn ignition key to OFF.</li> <li>• Disconnect EGR valve connector.</li> <li>• Check for poor connection (damaged/pulled-out terminals, corrosion, etc.).</li> <li>• Is there malfunction?</li> </ul>	Yes	Repair or replace terminals, then go to Step 11.
		No	Go to next step.
5	<b>INSPECT POWER CIRCUIT FOR OPEN CIRCUIT</b> <ul style="list-style-type: none"> <li>• Turn ignition key to ON (Engine OFF).</li> <li>• Measure voltage between EGR valve terminal D (harness-side) and body ground.</li> <li>• Is voltage <b>B+</b>?</li> </ul>	Yes	Inspect EGR valve coils 3 and 4. (See 01–16–15 EGR VALVE INSPECTION.) <ul style="list-style-type: none"> <li>• If there is a malfunction, replace EGR valve, and then go to Step 11.</li> <li>• If there is no malfunction, go to Step 11.</li> </ul>
		No	Repair or replace harness for open circuit, then go to Step 11.
6	<b>INSPECT EGR VALVE FOR POOR CONNECTION</b> <ul style="list-style-type: none"> <li>• Turn ignition key to OFF.</li> <li>• Disconnect EGR valve connector.</li> <li>• Check for poor connection (damaged/pulled-out terminals, corrosion, etc.).</li> <li>• Is there malfunction?</li> </ul>	Yes	Repair or replace terminals, then go to Step 11.
		No	Go to next step.
7	<b>INSPECT EGR VALVE</b> <ul style="list-style-type: none"> <li>• Measure resistance between EGR valve terminals D and B (part-side).</li> <li>• Is resistance <b>within 20—24 ohms</b>?</li> </ul>	Yes	Go to next step.
		No	Replace EGR valve, then go to Step 11.
8	<b>INSPECT PCM CONNECTOR FOR POOR CONNECTION</b> <ul style="list-style-type: none"> <li>• Disconnect PCM connector.</li> <li>• Check for poor connection at terminal 46 (damaged/pulled-out terminals, corrosion, etc.).</li> <li>• Is there malfunction?</li> </ul>	Yes	Repair terminals, then go to Step 11.
		No	Go to next step.
9	<b>INSPECT CONTROL CIRCUIT FOR SHORT</b> <ul style="list-style-type: none"> <li>• Check continuity between EGR valve terminal B (harness-side) and body ground.</li> <li>• Is there continuity?</li> </ul>	Yes	Repair or replace harness for short to ground, then go to Step 11.
		No	Measure voltage between EGR valve terminal B and body ground. <ul style="list-style-type: none"> <li>• If voltage is <b>B+</b>, repair or replace harness for short to power, then go to next step.</li> <li>• If voltage is <b>approx. 0 V</b>, go to next step.</li> </ul>
10	<b>INSPECT CONTROL CIRCUIT FOR OPEN CIRCUIT</b> <ul style="list-style-type: none"> <li>• Connect breakout box with PCM disconnected.</li> <li>• Check for continuity between EGR valve terminal B (harness-side) and breakout box terminal 46.</li> <li>• Is there continuity?</li> </ul>	Yes	Go to next step.
		No	Repair or replace harness for open, then go to next step.
11	<b>VERIFY TROUBLESHOOTING OF DTC P1498 COMPLETED</b> <ul style="list-style-type: none"> <li>• Make sure to reconnect all disconnected connectors.</li> <li>• Turn ignition key to OFF, then ON (Engine OFF).</li> <li>• Is same DTC present?</li> </ul>	Yes	Replace PCM, then go to next step.
		No	Go to next step.
12	<b>VERIFY AFTER REPAIR PROCEDURE</b> <ul style="list-style-type: none"> <li>• Perform “After Repair Procedure”. (See 01–02B–9 AFTER REPAIR PROCEDURE [FS].)</li> <li>• Is there any DTC present?</li> </ul>	Yes	Go to applicable DTC inspection. (See 01–02B–15 DTC TABLE [FS].)
		No	Troubleshooting completed.

# ON-BOARD DIAGNOSTIC [ENGINE CONTROL SYSTEM (FS)]

DTC P1499 [FS]

A3U010201083W08

01-02B

<b>DTC P1499</b>	<b>EGR valve stepping motor coil 4 open or short circuit</b>
<b>DETECTION CONDITION</b>	<ul style="list-style-type: none"> <li>PCM monitors input voltages from EGR valve coil control circuit just after turning ignition key to ON. If voltage at PCM terminal 56 remains low or high, PCM determines that EGR valve circuit has malfunction.</li> </ul> <p><b>Diagnostic support note</b></p> <ul style="list-style-type: none"> <li>This is a diagnostic support DTC (monitored once per key cycle).</li> <li>MIL does not illuminate.</li> <li>FREEZE FRAME DATA is not available.</li> <li>DTC is not stored in PCM memory.</li> </ul>
<b>POSSIBLE CAUSE</b>	<ul style="list-style-type: none"> <li>EGR valve malfunction</li> <li>Connector or terminal malfunction</li> <li>Short to ground circuit in wiring between EGR valve terminal F and PCM terminal 56</li> <li>Open circuit in wiring between EGR valve terminal F and PCM terminal 56</li> <li>Short to power circuit in wiring between EGR valve terminal F and PCM terminal 56</li> <li>Open circuit in wiring between main relay terminal D and EGR valve terminal D</li> <li>PCM malfunction</li> </ul>

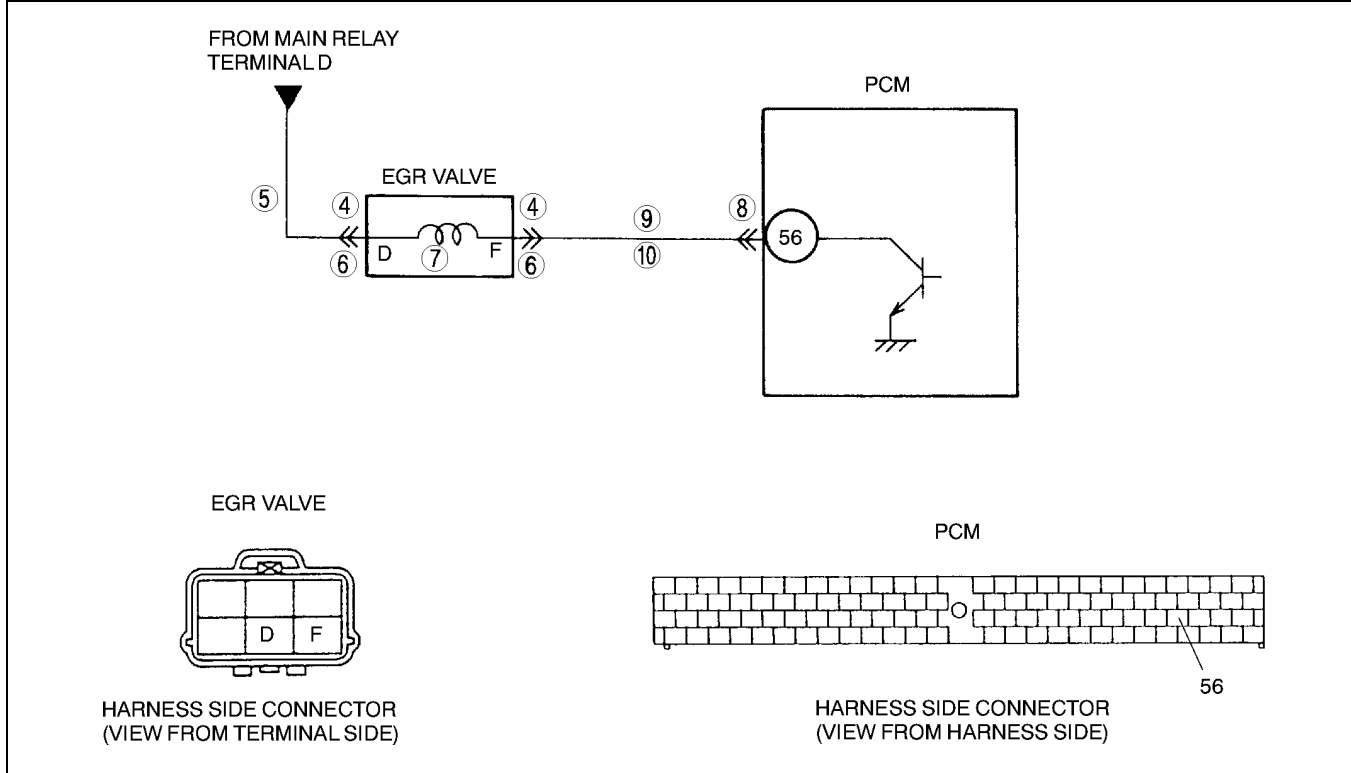

**Diagnostic procedure**

STEP	INSPECTION		ACTION
1	<b>VERIFY RELATED REPAIR INFORMATION AVAILABILITY</b> <ul style="list-style-type: none"> <li>Check for related Service Bulletins availability.</li> <li>Is any repair information available?</li> </ul>	Yes	Perform repair or diagnosis according to available repair information. <ul style="list-style-type: none"> <li>If vehicle is not repaired, go to next step.</li> </ul>
		No	Go to next step.
2	<b>CLASSIFY INTERMITTENT CONCERN OR CONTINUOUS CONCERN</b> <ul style="list-style-type: none"> <li>Turn ignition key to OFF then ON (Engine OFF).</li> <li>Is same DTC present?</li> </ul>	Yes	Go to next step.
		No	Refer to intermittent concern. (See 01-03B-4 INTERMITTENT CONCERN TROUBLESHOOTING [FS].)
3	<b>CLASSIFY POWER CIRCUIT OR CONTROL CIRCUIT MALFUNCTION</b> <ul style="list-style-type: none"> <li>Are same DTC and P1498 present?</li> </ul>	Yes	Malfunction at EGR valve or power circuit. Go to next step.
		No	Malfunction at EGR valve or control circuit. Go to Step 6.

## ON-BOARD DIAGNOSTIC [ENGINE CONTROL SYSTEM (FS)]

STEP	INSPECTION	ACTION	
4	<b>INSPECT EGR VALVE FOR POOR CONNECTION</b> <ul style="list-style-type: none"> <li>• Turn ignition key to OFF.</li> <li>• Disconnect EGR valve connector.</li> <li>• Check for poor connection (damaged/pulled-out terminals, corrosion, etc.).</li> <li>• Is there malfunction?</li> </ul>	Yes	Repair or replace terminals, then go to Step 11.
		No	Go to next step.
5	<b>INSPECT POWER CIRCUIT FOR OPEN CIRCUIT</b> <ul style="list-style-type: none"> <li>• Turn ignition key to ON (Engine OFF).</li> <li>• Measure voltage between EGR valve terminal D (harness-side) and body ground.</li> <li>• Is voltage <b>B+</b>?</li> </ul>	Yes	Inspect EGR valve coils 3 and 4. (See 01–16–15 EGR VALVE INSPECTION.) <ul style="list-style-type: none"> <li>• If there is a malfunction, replace EGR valve, and then go to Step 11.</li> <li>• If there is no malfunction, go to Step 11.</li> </ul>
		No	Repair or replace harness for open circuit, then go to Step 11.
6	<b>INSPECT EGR VALVE FOR POOR CONNECTION</b> <ul style="list-style-type: none"> <li>• Turn ignition key to OFF.</li> <li>• Disconnect EGR valve connector.</li> <li>• Check for poor connection (damaged/pulled-out terminals, corrosion, etc.).</li> <li>• Is there malfunction?</li> </ul>	Yes	Repair or replace terminals, then go to Step 11.
		No	Go to next step.
7	<b>INSPECT EGR VALVE</b> <ul style="list-style-type: none"> <li>• Measure resistance between EGR valve terminal D and F (part-side).</li> <li>• Is resistance <b>within 20—24 ohms</b>?</li> </ul>	Yes	Go to next step.
		No	Replace EGR valve, then go to Step 11.
8	<b>INSPECT PCM CONNECTOR FOR POOR CONNECTION</b> <ul style="list-style-type: none"> <li>• Disconnect PCM connector.</li> <li>• Check for poor connection at terminal 56 (damaged/pulled-out terminals, corrosion, etc.).</li> <li>• Is there malfunction?</li> </ul>	Yes	Repair terminal, then go to Step 11.
		No	Go to next step.
9	<b>INSPECT CONTROL CIRCUIT FOR SHORT</b> <ul style="list-style-type: none"> <li>• Check for continuity between EGR valve terminal F (harness-side) and body ground.</li> <li>• Is there continuity?</li> </ul>	Yes	Repair or replace harness for short to ground, then go to Step 11.
		No	Measure voltage between EGR valve terminal F and body ground. <ul style="list-style-type: none"> <li>• If voltage is <b>B+</b>, repair or replace harness for short to power, then go to next step.</li> <li>• If voltage is <b>approx. 0 V</b>, go to next step.</li> </ul>
10	<b>INSPECT CONTROL CIRCUIT FOR OPEN CIRCUIT</b> <ul style="list-style-type: none"> <li>• Connect breakout box with PCM disconnected.</li> <li>• Check for continuity between EGR valve terminal F (harness-side) and breakout box terminal 56.</li> <li>• Is there continuity?</li> </ul>	Yes	Go to next step.
		No	Repair or replace harness for open, then go to next step.
11	<b>VERIFY TROUBLESHOOTING OF DTC P1499 COMPLETED</b> <ul style="list-style-type: none"> <li>• Make sure to reconnect all disconnected connectors.</li> <li>• Turn ignition key to OFF, then ON (Engine OFF).</li> <li>• Is same DTC present?</li> </ul>	Yes	Replace PCM, then go to next step.
		No	Go to next step.
12	<b>VERIFY AFTER REPAIR PROCEDURE</b> <ul style="list-style-type: none"> <li>• Perform “After Repair Procedure”. (See 01–02B–9 AFTER REPAIR PROCEDURE [FS].)</li> <li>• Is there any DTC present?</li> </ul>	Yes	Go to applicable DTC inspection. (See 01–02B–15 DTC TABLE [FS].)
		No	Troubleshooting completed.

# ON-BOARD DIAGNOSTIC [ENGINE CONTROL SYSTEM (FS)]

DTC P1512 [FS]

A3U010201083W09

01-02B

<b>DTC P1512</b>	<b>Variable tumble control system (VTCS) shutter valve stuck closed</b>
<b>DETECTION CONDITION</b>	<ul style="list-style-type: none"> <li>• PCM monitors air flow amount is <b>above 45.2 g/s {6.0 lb/min}</b> when the following monitoring conditions are met. PCM determines that VTCS shutter valve has closed stuck malfunction.</li> </ul> <p><b>MONITORING CONDITIONS</b></p> <ul style="list-style-type: none"> <li>— Engine speed is <b>above 3,000 rpm</b>.</li> <li>— Engine coolant temperature is <b>above 70 °C {158 °F}</b>.</li> <li>— Throttle valve opening angle is <b>above 75%</b>.</li> </ul> <p><b>Diagnostic support note</b></p> <ul style="list-style-type: none"> <li>• This is a continuous monitor (CCM).</li> <li>• MIL illuminates if PCM detects the above the above malfunction condition in two consecutive drive cycles.</li> <li>• PENDING CODE is available if PCM detects the above malfunction condition during first drive cycle.</li> <li>• FREEZE FRAME DATA is available.</li> <li>• DTC is stored in PCM memory.</li> </ul>
<b>POSSIBLE CAUSE</b>	<ul style="list-style-type: none"> <li>• ECT sensor malfunction</li> <li>• MAF sensor malfunction</li> <li>• IAT sensor malfunction</li> <li>• EGR boost sensor malfunction</li> <li>• TP sensor malfunction</li> <li>• CKP sensor malfunction</li> <li>• VTCS solenoid valve malfunction</li> <li>• VTCS shutter valve malfunction (stuck closed)</li> <li>• VTCS shutter valve actuator malfunction (stuck closed).</li> <li>• Short to ground circuit between VTCS solenoid valve terminal B and PCM terminal 73</li> <li>• Short to power circuit between VTCS solenoid valve terminal B and PCM terminal 73</li> <li>• PCM malfunction</li> </ul>

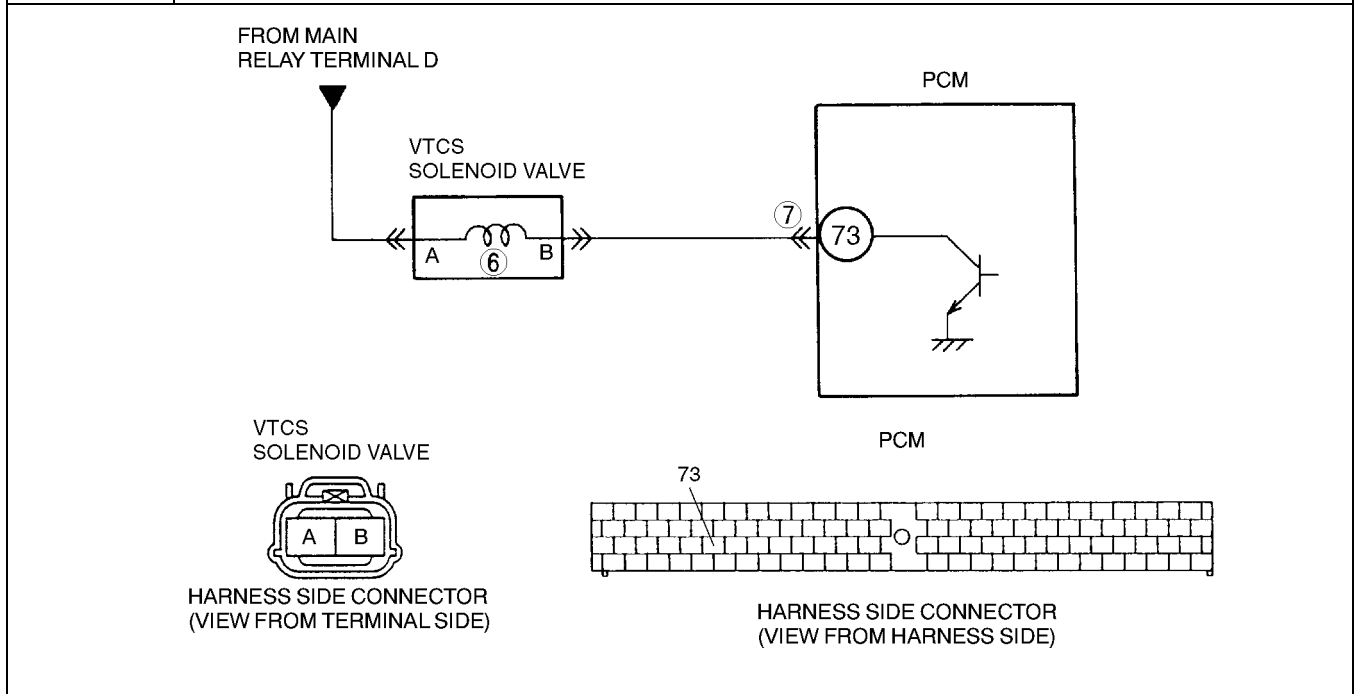

**Diagnostic procedure**

STEP	INSPECTION		ACTION
1	<b>CHECK FREEZE FRAME DATA HAS BEEN RECORDED</b> • Has FREEZE FRAME DATA been recorded?	Yes	Go to next step.
		No	Record FREEZE FRAME DATA on repair order, then go to next step.
2	<b>CHECK RELATED REPAIR INFORMATION AVAILABILITY</b> • Check for related Service Bulletins availability. • Is any related repair information available?	Yes	Perform repair or diagnosis according to available repair information. • If vehicle is not repaired, go to next step.
		No	Go to next step.

## ON-BOARD DIAGNOSTIC [ENGINE CONTROL SYSTEM (FS)]

STEP	INSPECTION	ACTION	
3	<b>CLASSIFY INTERMITTENT CONCERN OR CONTINUOUS CONCERN</b> <ul style="list-style-type: none"> <li>• Clear DTC from PCM memory using WDS or equipment.</li> <li>• Verify that following conditions are met.                             <ul style="list-style-type: none"> <li>— ECT: <b>at 20 °C {68 °F}</b></li> </ul> </li> <li>• Drive vehicle under following conditions:                             <ul style="list-style-type: none"> <li>— Engine speed: <b>above 3,000 rpm</b></li> <li>— MAF: <b>below 45.2 g/s {6.0 lb/min}</b></li> </ul> </li> <li>• Is pending code of same DTC present?</li> </ul>	Yes	Go to next step.
		No	Intermittent concern exists. Go to INTERMITTENT CONCERN TROUBLESHOOTING procedure. (See 01–03B–4 INTERMITTENT CONCERN TROUBLESHOOTING [FS].)
4	<b>VERIFY STORED OTHER DTCS</b> <ul style="list-style-type: none"> <li>• Verify stored DTCs using WDS or equipment.</li> <li>• Is other DTC present except P1512?</li> </ul>	Yes	Go to appropriate DTC troubleshooting procedures.
		No	Go to next step.
5	<b>INSPECT VTCS SHUTTER VALVE ACTUATOR</b> <ul style="list-style-type: none"> <li>• Carry out “VTCS operation inspection” (See 01–03B–57 Variable Tumble Control System (VTCS) Inspection.)</li> <li>• Is VTCS shutter valve actuator okay?</li> </ul>	Yes	Go to next step.
		No	Replace VTCS shutter valve actuator, then go to Step 8.
6	<b>INSPECT VTCS SOLENOID VALVE</b> <ul style="list-style-type: none"> <li>• Carry out “VTCS solenoid valve airflow inspection” (See 01–13B–15 VARIABLE TUMBLE CONTROL SYSTEM (VTCS) SOLENOID VALVE INSPECTION [FS].)</li> <li>• Is VTCS solenoid valve okay?</li> </ul>	Yes	Go to next step.
		No	Replace VTCS solenoid valve, then go to Step 8.
7	<b>CHECK PCM POOR CONNECTION</b> <ul style="list-style-type: none"> <li>• Check for poor connection at PCM terminal 73 (damaged/pulled-out terminals, corrosion, etc.).</li> <li>• Is there malfunction?</li> </ul>	Yes	Repair terminal, then go to next step.
		No	Go to next step.
8	<b>VERIFY TROUBLESHOOTING OF DTC P1512 COMPLETED</b> <ul style="list-style-type: none"> <li>• Make sure to reconnect all disconnected connectors.</li> <li>• Start engine.</li> <li>• Clear DTC from PCM memory using WDS or equipment.</li> <li>• Start engine.</li> <li>• Verify that following conditions are met.                             <ul style="list-style-type: none"> <li>— ECT: <b>at 20 °C {68 °F}</b></li> </ul> </li> <li>• Drive vehicle under following conditions:                             <ul style="list-style-type: none"> <li>— Engine speed: <b>above 3,000 rpm</b></li> <li>— MAF: <b>below 45.2 g/s {6.0 lb/min}</b></li> </ul> </li> <li>• Is pending code of same DTC present?</li> </ul>	Yes	Replace PCM, then go to next step.
		No	Go to next step.
9	<b>VERIFY AFTER REPAIR PROCEDURE</b> <ul style="list-style-type: none"> <li>• Perform “After Repair Procedure”. (See 01–02B–9 AFTER REPAIR PROCEDURE [FS].)</li> <li>• Is there any DTC present?</li> </ul>	Yes	Go to applicable DTC inspection. (See 01–02B–15 DTC TABLE [FS].)
		No	Troubleshooting completed.

### DTC P1562 [FS]

A3U010201083W10

DTC P1562	PCM +BB voltage low
<b>DETECTION CONDITION</b>	<ul style="list-style-type: none"> <li>• PCM monitors voltage of backup battery positive terminal at PCM terminal 55 after engine is started. If the PCM detected battery positive terminal voltage <b>below 2.5 V</b> for <b>2 seconds</b>, PCM determines that backup voltage circuit has malfunction.</li> </ul> <p><b>Diagnostic support note</b></p> <ul style="list-style-type: none"> <li>• This is a continuous monitor (CCM).</li> <li>• MIL illuminates if PCM detects the above malfunction condition during first drive cycle. Therefore, PENDING CODE is not available.</li> <li>• FREEZE FRAME DATA is available.</li> <li>• DTC is stored in PCM memory.</li> </ul>
<b>POSSIBLE CAUSE</b>	<ul style="list-style-type: none"> <li>• Open circuit or short to ground in wiring between battery positive terminal and PCM terminal 55</li> <li>• Poor connection of PCM connector</li> <li>• PCM malfunction</li> </ul>

## 01–02B–144



# ON-BOARD DIAGNOSTIC [ENGINE CONTROL SYSTEM (FS)]

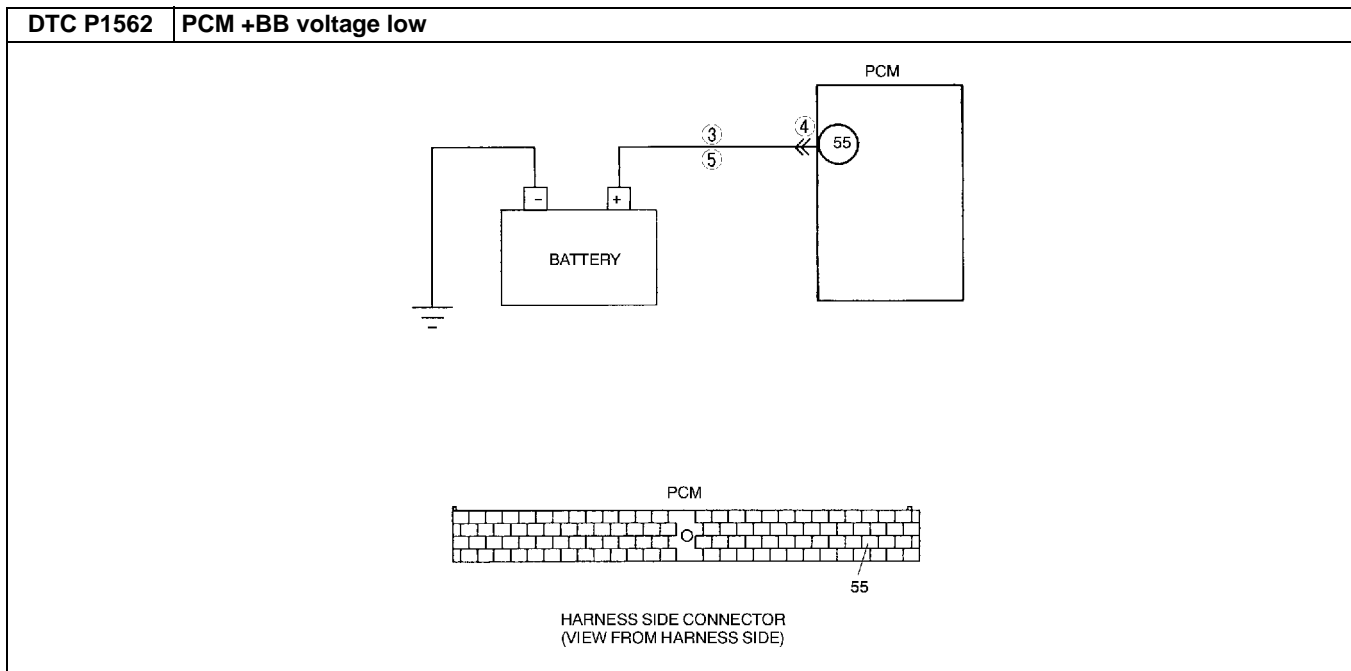

01-02B

## Diagnostic procedure

STEP	INSPECTION		ACTION
1	<b>VERIFY FREEZE FRAME DATA HAS BEEN RECORDED</b> <ul style="list-style-type: none"> <li>Has FREEZE FRAME DATA been recorded?</li> </ul>	Yes	Go to next step.
		No	Record FREEZE FRAME DATA on repair order, then go to next step.
2	<b>VERIFY RELATED REPAIR INFORMATION AVAILABILITY</b> <ul style="list-style-type: none"> <li>Check for related Service Bulletins availability.</li> <li>Is any repair information available?</li> </ul>	Yes	Perform repair or diagnosis according to available repair information. <ul style="list-style-type: none"> <li>If vehicle is not repaired, then go to next step.</li> </ul>
		No	Go to next step.
3	<b>INSPECT MONITOR CIRCUIT FOR SHORT TO GROUND</b> <ul style="list-style-type: none"> <li>Disconnect both battery cables.</li> <li>Measure resistance between battery positive cable and body ground.</li> <li>Is resistance more than <b>500 ohms</b>?</li> </ul>	Yes	Go to next step.
		No	Repair or replace harness between battery positive left terminal and PCM terminal 55 for short to ground, then go to Step 6.
4	<b>INSPECT PCM CONNECTOR FOR POOR CONNECTION</b> <ul style="list-style-type: none"> <li>Disconnect PCM connector.</li> <li>Check for poor connection at terminal 55 (damaged/pulled-out terminals, corrosion, etc.).</li> <li>Is there malfunction?</li> </ul>	Yes	Repair terminals, then go to Step 6.
		No	Go to next step.
5	<b>INSPECT MONITOR CIRCUIT FOR OPEN CIRCUIT</b> <ul style="list-style-type: none"> <li>Disconnect battery cables.</li> <li>Connect breakout box with PCM disconnected.</li> <li>Check for continuity between battery positive cable and breakout box terminal 55.</li> <li>Is there continuity?</li> </ul>	Yes	Go to next step.
		No	Repair or replace harness for open, then go to next step.
6	<b>VERIFY TROUBLESHOOTING OF DTC P1562 COMPLETED</b> <ul style="list-style-type: none"> <li>Make sure to reconnect all disconnected connectors.</li> <li>Clear DTC using WDS or equivalent.</li> <li>Turn ignition key to OFF, then start engine.</li> <li>Is same DTC present?</li> </ul>	Yes	Replace PCM, then go to next step.
		No	Go to next step.
7	<b>VERIFY AFTER REPAIR PROCEDURE</b> <ul style="list-style-type: none"> <li>Perform "After Repair Procedure". (See 01-02B-9 AFTER REPAIR PROCEDURE [FS].)</li> <li>Is there any DTC present?</li> </ul>	Yes	Go to applicable DTC inspection. (See 01-02B-15 DTC TABLE [FS].)
		No	Troubleshooting completed.

# ON-BOARD DIAGNOSTIC [ENGINE CONTROL SYSTEM (FS)]

**DTC P1569 [FS]**

A3U010201083W11

<b>DTC P1569</b>	<b>Variable tamble control system (VTCS) solenoid valve circuit low input</b>
<b>DETECTION CONDITION</b>	<ul style="list-style-type: none"> <li>PCM monitors input voltages from VTCS solenoid valve. If voltage at PCM terminal 73 is low when VTCS solenoid valve OFF, PCM determines that VTCS solenoid valve has malfunction.</li> </ul> <p><b>Diagnostic support note</b></p> <ul style="list-style-type: none"> <li>This is a continuous monitor (CCM).</li> <li>MIL illuminates if PCM detects the above the above malfunction condition in two consecutive drive cycles.</li> <li>PENDING CODE is available if PCM detects the above malfunction condition during first drive cycle.</li> <li>FREEZE FRAME DATA is available.</li> <li>DTC is stored in PCM memory.</li> </ul>
<b>POSSIBLE CAUSE</b>	<ul style="list-style-type: none"> <li>Poor connection of connectors at PCM and/or VTCS solenoid valve</li> <li>Short to ground in wiring between VTCS solenoid valve terminal B and PCM terminal 73</li> <li>Open circuit in wiring between main relay terminal D and VTCS solenoid valve terminal A</li> <li>Open circuit in wiring between VTCS solenoid valve terminal B and PCM terminal 73</li> <li>VTCS solenoid valve malfunction</li> <li>PCM malfunction</li> </ul>

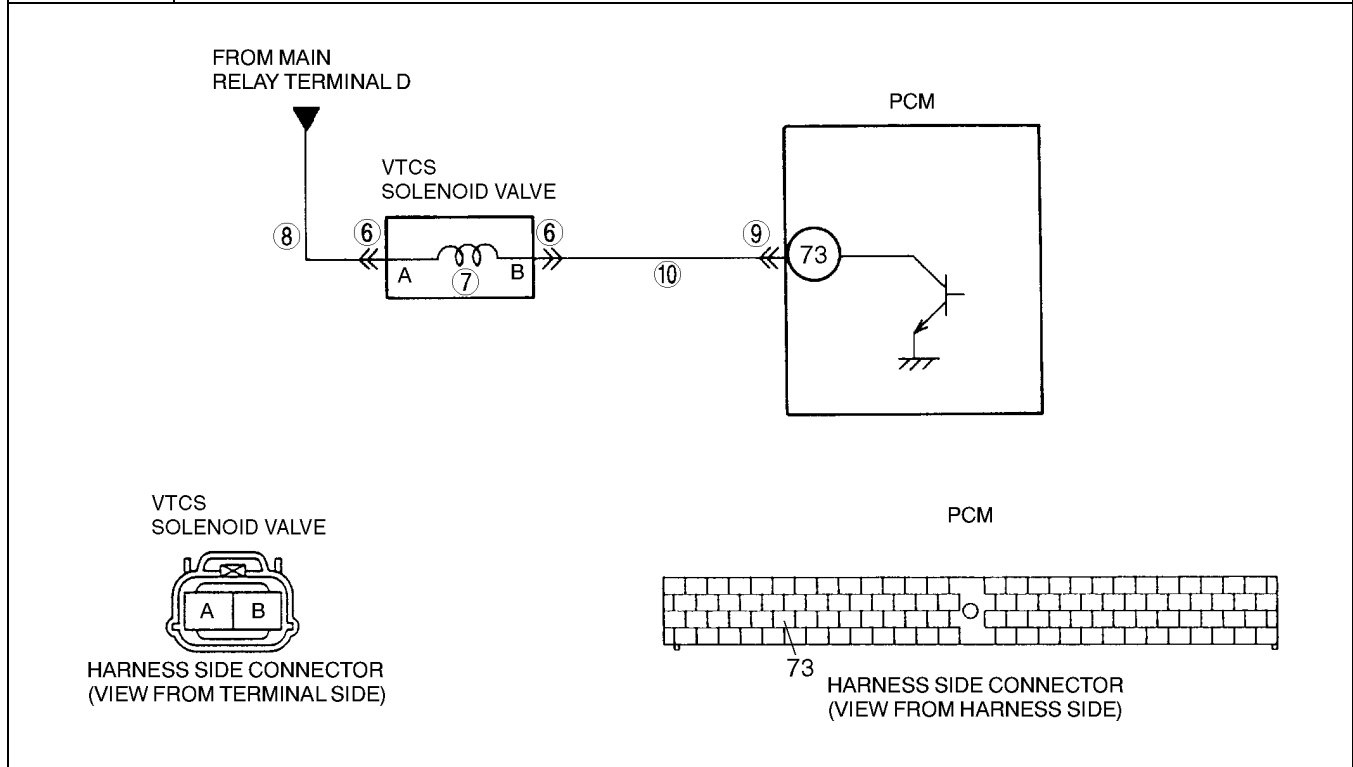

**Diagnostic procedure**

STEP	INSPECTION	ACTION
1	<b>CHECK FREEZE FRAME DATA HAS BEEN RECORDED</b> <ul style="list-style-type: none"> <li>Has FREEZE FRAME DATA been recorded?</li> </ul>	Yes Go to next step.
		No Record FREEZE FRAME DATA on repair order, then go to next step.
2	<b>VERIFY RELATED REPAIR INFORMATION AVAILABILITY</b> <ul style="list-style-type: none"> <li>Check for related Service Bulletins availability.</li> <li>Is any related repair information available?</li> </ul>	Yes Perform repair or diagnosis according to available repair information. <ul style="list-style-type: none"> <li>If vehicle is not repaired, go to next step.</li> </ul>
		No Go to next step.
3	<b>CLASSIFY INTERMITTENT CONCERN OR CONTINUOUS CONCERN</b> <ul style="list-style-type: none"> <li>Clear DTC from PCM memory using WDS or equipment.</li> <li>Start engine.</li> <li>Is same DTC present?</li> </ul>	Yes Go to next step.
		No Intermittent concern exists. Go to INTERMITTENT CONCERN TROUBLESHOOTING procedure. (See 01-03B-4 INTERMITTENT CONCERN TROUBLESHOOTING [FS].)

## ON-BOARD DIAGNOSTIC [ENGINE CONTROL SYSTEM (FS)]

STEP	INSPECTION	ACTION	
4	<b>CLASSIFY OPEN CIRCUIT OR SHORT TO GROUND MALFUNCTION</b> <ul style="list-style-type: none"> <li>• Disconnect VTCS solenoid valve tube that connects to intake manifold.</li> <li>• Connect vacuum pump to VTCS solenoid valve.</li> <li>• Apply vacuum and wait <b>5 seconds</b>.</li> <li>• Is vacuum maintained?</li> </ul>	Yes	Go to Step 6.
		No	Go to next step.
5	<b>INSPECT PASSAGE CONTROL OF VTCS SOLENOID VALVE</b> <ul style="list-style-type: none"> <li>• Turn ignition key to OFF.</li> <li>• Disconnect VTCS solenoid valve connector.</li> <li>• Is vacuum maintained?</li> </ul>	Yes	Repair or replace harness between PCM terminal 73 and VTCS solenoid valve terminal B for short to ground, then go to Step 11.
		No	Replace VTCS solenoid valve, then go to Step 11.
6	<b>INSPECT VTCS SOLENOID VALVE CONNECTOR FOR POOR CONNECTION</b> <ul style="list-style-type: none"> <li>• Turn ignition key to OFF.</li> <li>• Check for poor connection (damaged/pulled-out pins, corrosion, etc.).</li> <li>• Is there malfunction?</li> </ul>	Yes	Repair or replace terminal, then go to Step 11.
		No	Go to next step.
7	<b>INSPECT VTCS SOLENOID VALVE</b> <ul style="list-style-type: none"> <li>• Measure resistance between VTCS solenoid valve terminals (part-side).</li> <li>• Is resistance <b>within 22—26 ohms</b>?</li> </ul>	Yes	Go to next step.
		No	Replace VTCS solenoid valve, then go to Step 11.
8	<b>INSPECT VTCS SOLENOID VALVE POWER SUPPLY CIRCUIT FOR OPEN CIRCUIT</b> <ul style="list-style-type: none"> <li>• Disconnect VTCS solenoid valve connector.</li> <li>• Turn ignition key to ON (Engine OFF).</li> <li>• Measure voltage between VTCS solenoid valve terminal A (harness-side) and body ground.</li> <li>• Is voltage <b>B+</b>?</li> </ul>	Yes	Go to next step.
		No	Repair or replace harness for open, then go to Step 11.
9	<b>INSPECT PCM CONNECTOR FOR POOR CONNECTION</b> <ul style="list-style-type: none"> <li>• Turn ignition key to OFF.</li> <li>• Disconnect PCM connector.</li> <li>• Check for poor connection at PCM terminal 73. (damaged/pulled-out pins, corrosion, etc.).</li> <li>• Is there malfunction?</li> </ul>	Yes	Repair terminal, then go to Step 11.
		No	Go to next step.
10	<b>INSPECT VTCS SOLENOID VALVE CONTROL CIRCUIT FOR OPEN CIRCUIT</b> <ul style="list-style-type: none"> <li>• Connect VTCS solenoid valve connector.</li> <li>• Connect breakout box with PCM disconnected.</li> <li>• Turn ignition key to ON (Engine OFF).</li> <li>• Measure voltage between breakout box terminal 73 and body ground.</li> <li>• Is voltage <b>B+</b>?</li> </ul>	Yes	Go to next step.
		No	Repair or replace harness for open or short to ground circuit, then go to next step.
11	<b>VERIFY TROUBLESHOOTING OF DTC P1569 COMPLETED</b> <ul style="list-style-type: none"> <li>• Make sure to reconnect all disconnected connectors.</li> <li>• Clear DTC from PCM memory using WDS or equivalent.</li> <li>• Start engine.</li> <li>• Verify that following conditions are met.                             <ul style="list-style-type: none"> <li>— ECT: <b>above 65 °C {149 °F}</b></li> <li>— Engine speed: <b>below 3,250 rpm</b></li> </ul> </li> <li>• Is pending code of same DTC present?</li> </ul>	Yes	Replace PCM, then go to next step.
		No	Go to next step.
12	<b>VERIFY AFTER REPAIR PROCEDURE</b> <ul style="list-style-type: none"> <li>• Perform "After Repair Procedure". (See 01-02B-9 AFTER REPAIR PROCEDURE [FS].)</li> <li>• Is there any DTC present?</li> </ul>	Yes	Go to applicable DTC inspection. (See 01-02B-15 DTC TABLE [FS].)
		No	Troubleshooting completed.

01-02B

# ON-BOARD DIAGNOSTIC [ENGINE CONTROL SYSTEM (FS)]

DTC P1570 [FS]

A3U010201083W12

<b>DTC P1570</b>	<b>Variable tumble control system (VTCS) solenoid valve circuit high input</b>
<b>DETECTION CONDITION</b>	<ul style="list-style-type: none"> <li>• PCM monitors input voltages from VTCS solenoid valve. If voltage at PCM 73 is high when the VTCS solenoid valve ON, PCM determines that VTCS solenoid valve malfunction.</li> </ul> <p><b>MONITORING CONDITIONS</b></p> <ul style="list-style-type: none"> <li>— Engine speed is <b>below 3,250 rpm</b>.</li> <li>— Engine coolant temperature is <b>below 65°C {149 °F}</b>.</li> <li>— Throttle valve opening angle is <b>below 14% for ATX, 12.50% for MTX [at engine speed 2,500 rpm]</b>.</li> </ul> <p><b>Diagnostic support note</b></p> <ul style="list-style-type: none"> <li>• This is a continuous monitor (CCM).</li> <li>• MIL illuminates if PCM detects the above the above malfunction condition in two consecutive drive cycles.</li> <li>• PENDING CODE is available if PCM detects the above malfunction condition during first drive cycle.</li> <li>• FREEZE FRAME DATA is available.</li> <li>• DTC is stored in PCM memory.</li> </ul>
<b>POSSIBLE CAUSE</b>	<ul style="list-style-type: none"> <li>• Poor connection of connectors at PCM and/or VTCS solenoid valve</li> <li>• Short to power circuit in wiring between VTCS solenoid valve terminal B and PCM terminal 73</li> <li>• Open circuit in wiring between main relay terminal D and VTCS solenoid valve terminal A</li> <li>• Open circuit in wiring between VTCS solenoid valve terminal B and PCM terminal 73</li> <li>• VTCS solenoid valve malfunction</li> <li>• PCM malfunction</li> </ul>

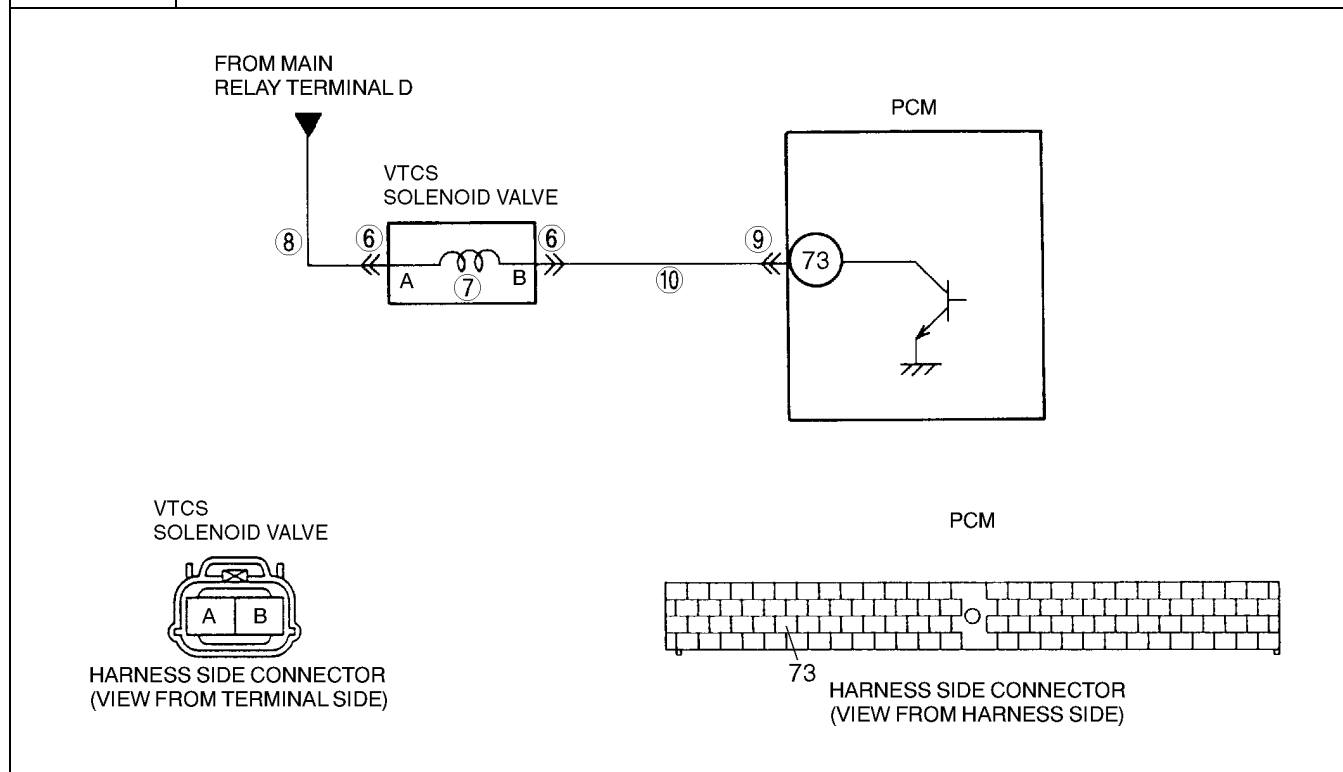

**Diagnostic procedure**

STEP	INSPECTION		ACTION
1	<b>CHECK FREEZE FRAME DATA HAS BEEN RECORDED</b> <ul style="list-style-type: none"> <li>• Has FREEZE FRAME DATA been recorded?</li> </ul>	Yes	Go to next step.
		No	Record FREEZE FRAME DATA on repair order, then go to next step.
2	<b>VERIFY RELATED REPAIR INFORMATION AVAILABILITY</b> <ul style="list-style-type: none"> <li>• Check for related Service Bulletins availability.</li> <li>• Is any related repair information available?</li> </ul>	Yes	Perform repair or diagnosis according to available repair information. <ul style="list-style-type: none"> <li>• If vehicle is not repaired, go to next step.</li> </ul>
		No	Go to next step.

## ON-BOARD DIAGNOSTIC [ENGINE CONTROL SYSTEM (FS)]

STEP	INSPECTION	ACTION	
3	<b>CLASSIFY INTERMITTENT CONCERN OR CONTINUOUS CONCERN</b> <ul style="list-style-type: none"> <li>• Clear DTC from PCM memory using WDS or equipment.</li> <li>• Start engine.</li> <li>• Drive vehicle under following conditions:                             <ul style="list-style-type: none"> <li>— Engine speed is <b>below 3,250 rpm</b>.</li> <li>— Engine coolant temperature is <b>below 65°C {149 °F}</b>.</li> <li>— Throttle valve opening angle is <b>below 14% for ATX, 12.50% for MTX [at engine speed 2,500 rpm]</b>.</li> </ul> </li> <li>• Is pending code of same DTC present?</li> </ul>	Yes	Go to next step.
		No	Intermittent concern exists. Go to INTERMITTENT CONCERN TROUBLESHOOTING procedure. (See 01–03B–4 INTERMITTENT CONCERN TROUBLESHOOTING [FS].)
4	<b>CLASSIFY OPEN CIRCUIT OR SHORT TO GROUND MALFUNCTION</b> <ul style="list-style-type: none"> <li>• Disconnect VTCS solenoid valve tube that connects to intake manifold.</li> <li>• Connect vacuum pump to VTCS solenoid valve.</li> <li>• Apply vacuum and wait <b>5 seconds</b>.</li> <li>• Is vacuum maintained?</li> </ul>	Yes	Go to Step 6.
		No	Go to next step.
5	<b>INSPECT PASSAGE CONTROL OF VTCS SOLENOID VALVE</b> <ul style="list-style-type: none"> <li>• Turn ignition key to OFF.</li> <li>• Disconnect VTCS solenoid valve connector.</li> <li>• Is vacuum maintained?</li> </ul>	Yes	Repair or replace harness between PCM terminal 73 and VTCS solenoid valve terminal B for short to ground, then go to Step 11.
		No	Replace VTCS solenoid valve, then go to Step 11.
6	<b>INSPECT POOR CONNECTION OF VTCS SOLENOID VALVE CONNECTOR</b> <ul style="list-style-type: none"> <li>• Turn ignition key to OFF.</li> <li>• Check for poor connection (damaged/pulled-out pins, corrosion, etc.).</li> <li>• Is there malfunction?</li> </ul>	Yes	Repair or replace terminal, then go to Step 11.
		No	Go to next step.
7	<b>INSPECT VTCS SOLENOID VALVE</b> <ul style="list-style-type: none"> <li>• Measure resistance between VTCS solenoid valve terminals (part-side).</li> <li>• Is resistance <b>within 22—26 ohms</b>?</li> </ul>	Yes	Go to next step.
		No	Replace VTCS solenoid valve, then go to Step 11.
8	<b>INSPECT VTCS SOLENOID VALVE POWER SUPPLY CIRCUIT FOR OPEN CIRCUIT</b> <ul style="list-style-type: none"> <li>• Disconnect VTCS solenoid valve connector.</li> <li>• Turn ignition key to ON (Engine OFF).</li> <li>• Measure voltage between VTCS solenoid valve terminal A (harness-side) and body ground.</li> <li>• Is voltage <b>B+</b>?</li> </ul>	Yes	Go to next step.
		No	Repair or replace harness for open, then go to Step 11.
9	<b>INSPECT PCM CONNECTOR FOR POOR CONNECTION</b> <ul style="list-style-type: none"> <li>• Turn ignition key to OFF.</li> <li>• Disconnect PCM connector.</li> <li>• Check for poor connection at PCM terminal 73. (damaged/pulled-out pins, corrosion, etc.).</li> <li>• Is there malfunction?</li> </ul>	Yes	Repair terminal, then go to Step 11.
		No	Go to next step.
10	<b>INSPECT VTCS SOLENOID VALVE CONTROL CIRCUIT FOR SHORT TO POWER</b> <ul style="list-style-type: none"> <li>• Disconnect VTCS solenoid valve connector.</li> <li>• Connect breakout box with PCM disconnected.</li> <li>• Turn ignition key to ON (Engine OFF).</li> <li>• Measure voltage between breakout box terminal 73 and body ground.</li> <li>• Is voltage <b>B+</b>?</li> </ul>	Yes	Repair or replace harness for short to power circuit, then go to next step.
		No	Go to next step.

01–02B

# ON-BOARD DIAGNOSTIC [ENGINE CONTROL SYSTEM (FS)]

STEP	INSPECTION		ACTION
11	<b>VERIFY TROUBLESHOOTING OF DTC P1570 COMPLETED</b> <ul style="list-style-type: none"> <li>Make sure to reconnect all disconnected connectors.</li> <li>Clear DTC from PCM memory using WDS or equipment.</li> <li>Start engine.</li> <li>Drive vehicle under following conditions:                             <ul style="list-style-type: none"> <li>— Engine speed is <b>above 3,250 rpm</b>.</li> <li>— Engine coolant temperature is <b>below 65°C {149 °F}</b>.</li> <li>— Throttle valve opening angle is <b>below 14% for ATX 12.50% for MTX [at engine speed 2,500 rpm]</b>.</li> </ul> </li> <li>Is pending code of same DTC present?</li> </ul>	Yes	Replace PCM, then go to next step.
		No	Go to next step.
12	<b>VERIFY AFTER REPAIR PROCEDURE</b> <ul style="list-style-type: none"> <li>Perform "After Repair Procedure". (See 01-02B-9 AFTER REPAIR PROCEDURE [FS].)</li> <li>Is there any DTC present?</li> </ul>	Yes	Go to applicable DTC inspection. (See 01-02B-15 DTC TABLE [FS].)
		No	Troubleshooting completed.

## DTC P1631 [FS]

A3U010201083W13

<b>DTC P1631</b>	<b>Generator output voltage signal no electricity</b>
<b>DETECTION CONDITION</b>	<ul style="list-style-type: none"> <li>PCM monitors input voltage from generator. If PCM detect generator output voltage <b>below 8.5 V</b> or generated current <b>above 19.5 A</b> for <b>5 seconds</b> while engine running, PCM determines that charging system has malfunction.</li> </ul>
<b>POSSIBLE CAUSE</b>	<ul style="list-style-type: none"> <li>Open or short to ground circuit between generator terminal P and PCM terminal 30</li> <li>Open or short to ground circuit between generator terminal D and PCM terminal 53</li> <li>Drive belt is cut off or has come off</li> <li>Generator malfunction                             <ul style="list-style-type: none"> <li>— Rectifier circuit malfunction</li> <li>— Brush abrasion</li> </ul> </li> <li>PCM malfunction</li> </ul>

GENERATOR

HARNESS SIDE CONNECTOR  
(VIEW FROM TERMINAL SIDE)

PCM

HARNESS SIDE CONNECTOR  
(VIEW FROM HARNESS SIDE)

## ON-BOARD DIAGNOSTIC [ENGINE CONTROL SYSTEM (FS)]

### Diagnostic procedure

STEP	INSPECTION	ACTION	
1	<b>VERIFY RELATED REPAIR INFORMATION AVAILABILITY</b> <ul style="list-style-type: none"> <li>• Check for related Service Bulletins availability.</li> <li>• Is any related repair information available?</li> </ul>	Yes	Perform repair or diagnosis according to available repair information. <ul style="list-style-type: none"> <li>• If vehicle is not repaired, go to next step.</li> </ul>
		No	Go to next step.
2	<b>INSPECT DRIVE BELT CONDITION</b> <ul style="list-style-type: none"> <li>• Verify that drive belt auto tensioner indicator mark in not exceeding limit. (See 01-10B-3 DRIVE BELT INSPECTION [FS].)</li> <li>• Is front drive belt okay?</li> </ul>	Yes	Go to next step.
		No	Replace and/or adjust drive belt, then go to Step 9.
3	<b>INSPECT PCM CONNECTOR FOR POOR CONNECTION</b> <ul style="list-style-type: none"> <li>• Turn ignition key to OFF.</li> <li>• Disconnect PCM connector.</li> <li>• Check for poor connection (damaged/pulled-out terminals, corrosion, etc.).</li> <li>• Are there any malfunctions?</li> </ul>	Yes	Repair terminals, then go to Step 9.
		No	Go to next step.
4	<b>INSPECT GENERATOR CONNECTOR FOR POOR CONNECTION</b> <ul style="list-style-type: none"> <li>• Disconnect generator connector.</li> <li>• Check for poor connection (damaged/pulled-out terminals, corrosion, etc.).</li> <li>• Are there any malfunctions?</li> </ul>	Yes	Repair or replace terminals, then go to Step 9.
		No	Go to next step.
5	<b>INSPECT GENERATOR CONTROL CIRCUIT FOR SHORT TO GROUND</b> <ul style="list-style-type: none"> <li>• Check for continuity between generator terminal D (harness-side) and body ground.</li> <li>• Is there continuity?</li> </ul>	Yes	Repair or replace harness for short to ground, then go to Step 9.
		No	Go to next step.
6	<b>INSPECT GENERATOR OUTPUT VOLTAGE MONITOR CIRCUIT FOR GROUND</b> <ul style="list-style-type: none"> <li>• Check continuity between generator terminal P (harness-side) and body ground.</li> <li>• Is there continuity?</li> </ul>	Yes	Repair or replace harness for short to ground, then go to Step 9.
		No	Go to next step.
7	<b>INSPECT GENERATOR CONTROL CIRCUIT FOR OPEN CIRCUIT</b> <ul style="list-style-type: none"> <li>• Connect breakout box with PCM disconnected.</li> <li>• Measure resistance between generator terminal D (harness-side) and breakout box terminal 53.</li> <li>• Is there continuity?</li> </ul>	Yes	Go to next step.
		No	Repair or replace harness for open circuit, then go to Step 9.
8	<b>INSPECT GENERATOR OUTPUT VOLTAGE MONITOR CIRCUIT FOR OPEN CIRCUIT</b> <ul style="list-style-type: none"> <li>• Measure resistance between generator terminal P (harness-side) and breakout box terminal 30.</li> <li>• Is there continuity?</li> </ul>	Yes	Repair or replace generator, then go to next step.
		No	Repair or replace harness for open, then go to next step.
9	<b>VERIFY TROUBLESHOOTING OF DTC P1631 COMPLETED</b> <ul style="list-style-type: none"> <li>• Make sure to reconnect all disconnected connectors.</li> <li>• Clear DTC from memory using WDS or equivalent.</li> <li>• Turn ignition switch to OFF, then start engine.</li> <li>• Is same DTC present?</li> </ul>	Yes	Replace PCM, then go to next step.
		No	No concern is detected. Go to next step.
10	<b>VERIFY AFTER REPAIR PROCEDURE</b> <ul style="list-style-type: none"> <li>• Perform "After Repair Procedure". (See 01-02B-9 AFTER REPAIR PROCEDURE [FS].)</li> <li>• Is there any DTC present?</li> </ul>	Yes	Go to applicable DTC inspection. (See 01-02B-15 DTC TABLE [FS].)
		No	Troubleshooting completed.

01-02B

# ON-BOARD DIAGNOSTIC [ENGINE CONTROL SYSTEM (FS)]

**DTC P1632 [FS]**

A3U010201083W14

<b>DTC P1632</b>	<b>Battery voltage monitor signal circuit malfunction</b>
<b>DETECTION CONDITION</b>	<ul style="list-style-type: none"> <li>PCM monitors voltage of battery positive terminal at PCM terminal 4. If PCM detects battery positive terminal voltage <b>below 7.97 V for 5 seconds</b>, PCM determines that battery positive voltage circuit has malfunction.</li> </ul>
<b>POSSIBLE CAUSE</b>	<ul style="list-style-type: none"> <li>Open circuit in wiring between battery positive terminal and PCM terminal 4</li> <li>Poor connection of PCM connector</li> <li>PCM malfunction</li> </ul>

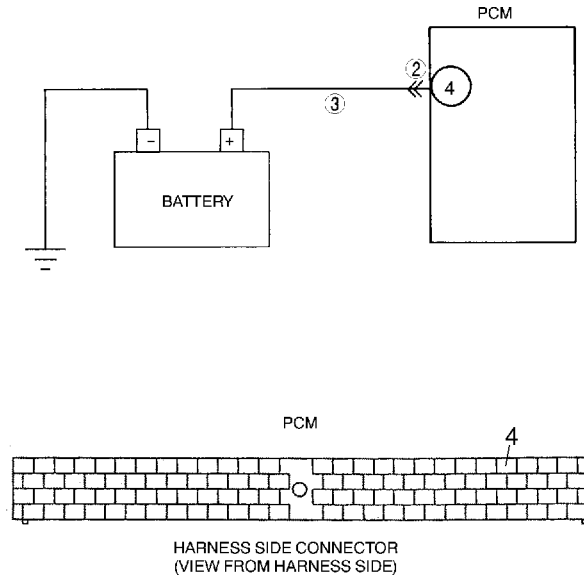

**Diagnostic procedure**

STEP	INSPECTION	ACTION
1	<b>VERIFY RELATED REPAIR INFORMATION AVAILABILITY</b> <ul style="list-style-type: none"> <li>Check for related Service Bulletins availability.</li> <li>Is any related repair information available?</li> </ul>	Yes Perform repair or diagnosis according to available repair information. • If vehicle is not repaired, go to next step.
		No Go to next step.
2	<b>INSPECT PCM CONNECTOR FOR POOR CONNECTION</b> <ul style="list-style-type: none"> <li>Disconnect PCM connector.</li> <li>Check for poor connection (damaged/pulled-out terminals, corrosion, etc.).</li> <li>Is there malfunction?</li> </ul>	Yes Repair terminals, then go to Step 5.
		No Go to next step.
3	<b>INSPECT MONITOR CIRCUIT FOR OPEN CIRCUIT</b> <ul style="list-style-type: none"> <li>Disconnect battery cables.</li> <li>Check for continuity between Battery positive terminal and PCM terminal 4.</li> <li>Is there continuity?</li> </ul>	Yes Go to next step.
		No Repair or replace harness, then go to next step.
4	<b>VERIFY TROUBLESHOOTING OF DTC P1632 COMPLETED</b> <ul style="list-style-type: none"> <li>Make sure to reconnect all disconnected connectors.</li> <li>Clear DTC from memory using WDS or equivalent.</li> <li>Turn ignition key to OFF, then start engine.</li> <li>Is same DTC present?</li> </ul>	Yes Replace PCM, then go to next step.
		No No concern is detected. Go to next step.
5	<b>VERIFY AFTER REPAIR PROCEDURE</b> <ul style="list-style-type: none"> <li>Perform "After Repair Procedure". (See 01-02B-9 AFTER REPAIR PROCEDURE [FS].)</li> <li>Is there any DTC present?</li> </ul>	Yes Go to applicable DTC inspection. (See 01-02B-15 DTC TABLE [FS].)
		No Troubleshooting completed.



# ON-BOARD DIAGNOSTIC [ENGINE CONTROL SYSTEM (FS)]

DTC P1633 [FS]

A3U010201083W15

<b>DTC P1633</b>	<b>Battery overcharge</b>
<b>DETECTION CONDITION</b>	<ul style="list-style-type: none"> <li>PCM monitors input voltage from generator and battery positive terminal. If PCM detects generator output voltage <b>above 18.47 V</b> or battery voltage <b>above 15.94 V</b> for <b>5 seconds</b> while engine running, PCM determines that charging system has malfunction.</li> </ul>
<b>POSSIBLE CAUSE</b>	<ul style="list-style-type: none"> <li>Short to power circuit between generator connector terminal D and PCM connector terminal 53</li> <li>Generator malfunction</li> <li>PCM malfunction</li> </ul>

01-02B

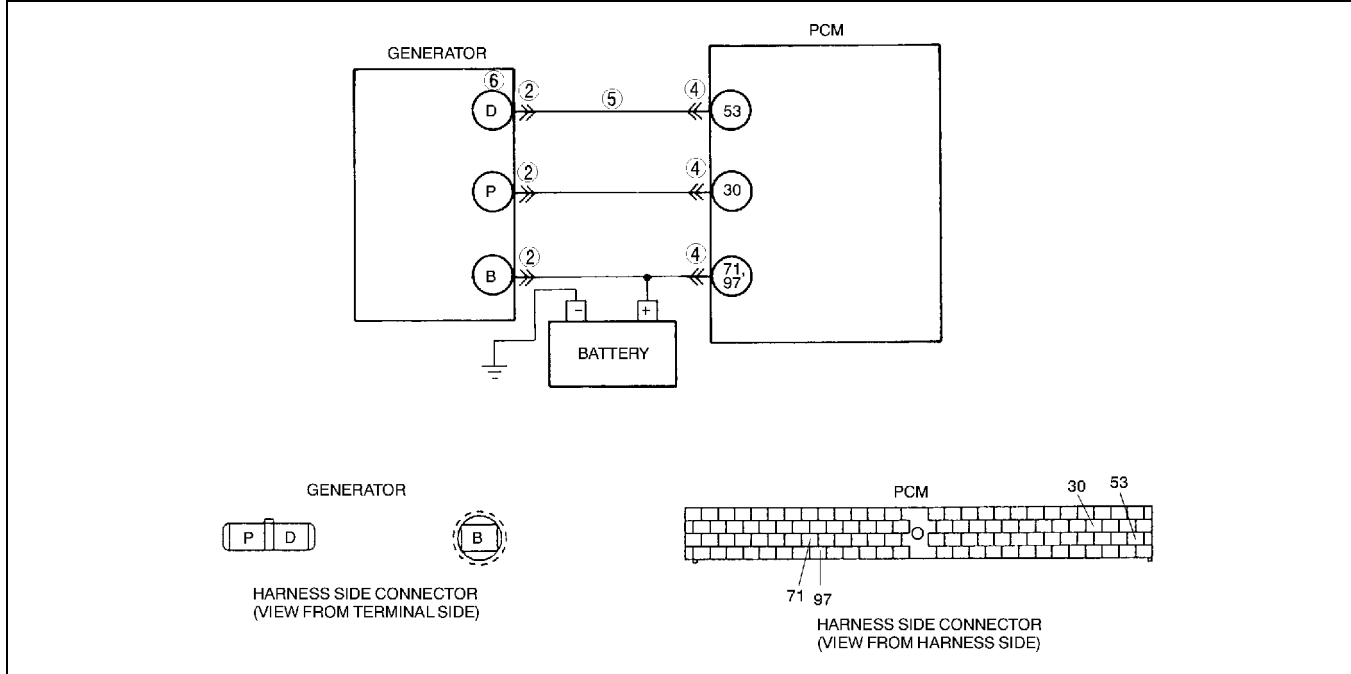

**Diagnostic procedure**

STEP	INSPECTION	ACTION
1	<b>VERIFY RELATED REPAIR INFORMATION AVAILABILITY</b> <ul style="list-style-type: none"> <li>Check for related Service Bulletins availability.</li> <li>Is any related repair information available?</li> </ul>	Yes Perform repair or diagnosis according to available repair information. • If vehicle is not repaired, go to next step.
		No Go to next step.
2	<b>INSPECT GENERATOR CONNECTOR FOR POOR CONNECTION</b> <ul style="list-style-type: none"> <li>Turn ignition key to OFF.</li> <li>Disconnect generator connector.</li> <li>Check for poor connection (damaged/pulled-out terminals, corrosion, etc.).</li> <li>Is there malfunction?</li> </ul>	Yes Repair or replace terminals, then go to Step 7.
		No Go to next step.
3	<b>CLASSIFY GENERATOR MALFUNCTION OR OTHER MALFUNCTION</b> <ul style="list-style-type: none"> <li>Turn ignition key to ON (Engine OFF).</li> <li>Measure voltage between generator terminal D (harness-side) and body ground.</li> <li>Is voltage <b>B+</b>?</li> </ul>	Yes Go to next step.
		No Malfunction at generator. Go to Step 6.
4	<b>INSPECT PCM CONNECTOR FOR POOR CONNECTION</b> <ul style="list-style-type: none"> <li>Turn ignition key to OFF.</li> <li>Disconnect PCM connector.</li> <li>Check for poor connection (damaged/pulled-out terminals, corrosion, etc.).</li> <li>Is there malfunction?</li> </ul>	Yes Repair or replace pins, then go to Step 7.
		No Go to next step.
5	<b>INSPECT GENERATOR CONTROL CIRCUIT FOR SHORT TO POWER</b> <ul style="list-style-type: none"> <li>Turn ignition key to ON (Engine OFF).</li> <li>Measure voltage between generator terminal D (harness-side) and body ground.</li> <li>Is voltage <b>B+</b>?</li> </ul>	Yes Repair or replace harness for short to power, then go to Step 7.
		No Go to Step 7.

# ON-BOARD DIAGNOSTIC [ENGINE CONTROL SYSTEM (FS)]

STEP	INSPECTION	ACTION	
6	<b>INSPECT GENERATOR CONTROL TERMINAL FOR SHORT TO POWER</b> <ul style="list-style-type: none"> <li>Measure resistance between generator terminal D (part-side) and body ground.</li> <li>Is voltage <b>B+</b>?</li> </ul>	Yes	Repair or replace generator, then go to Step 7.
		No	Go to next step.
7	<b>VERIFY TROUBLESHOOTING OF DTC P1633 COMPLETED</b> <ul style="list-style-type: none"> <li>Make sure to reconnect all disconnected connectors.</li> <li>Clear DTC from PCM memory using WDS or equivalent.</li> <li>Turn ignition key to OFF, then start engine.</li> <li>Is same DTC present?</li> </ul>	Yes	Replace PCM, then go to next step.
		No	No concern is detected. Go to next step.
8	<b>VERIFY AFTER REPAIR PROCEDURE</b> <ul style="list-style-type: none"> <li>Perform "After Repair Procedure". (See 01-02B-9 AFTER REPAIR PROCEDURE [FS].)</li> <li>Is there any DTC present?</li> </ul>	Yes	Go to applicable DTC inspection. (See 01-02B-15 DTC TABLE [FS].)
		No	Troubleshooting completed.

## DTC P1634 [FS]

A3U010201083W16

<b>DTC P1634</b>	<b>Generator terminal B circuit open</b>
<b>DETECTION CONDITION</b>	<ul style="list-style-type: none"> <li>PCM monitors input voltage from generator and battery positive terminal. If PCM detects generator output voltage <b>above 16.97 V</b> and battery voltage <b>below 10.94 V</b> for <b>5 seconds</b> while engine running, PCM determines that charging system has malfunction.</li> </ul>
<b>POSSIBLE CAUSE</b>	<ul style="list-style-type: none"> <li>Open circuit between generator terminal B and battery positive terminal</li> <li>Battery malfunction</li> <li>PCM malfunction</li> </ul>

## ON-BOARD DIAGNOSTIC [ENGINE CONTROL SYSTEM (FS)]

### Diagnostic procedure

STEP	INSPECTION	ACTION	
1	<b>VERIFY RELATED REPAIR INFORMATION AVAILABILITY</b> <ul style="list-style-type: none"> <li>• Check for related Service Bulletins availability.</li> <li>• Is any related repair information available?</li> </ul>	Yes	Perform repair or diagnosis according to available repair information. <ul style="list-style-type: none"> <li>• If vehicle is not repaired, go to next step.</li> </ul>
		No	Go to next step.
2	<b>INSPECT BATTERY</b> <ul style="list-style-type: none"> <li>• Turn ignition key to OFF.</li> <li>• Inspect battery.</li> <li>(See 01-17-1 BATTERY INSPECTION.)</li> <li>• Is battery okay?</li> </ul>	Yes	Replace battery, then go to Step 6.
		No	Go to next step.
3	<b>INSPECT GENERATOR TERMINAL FOR POOR INSTALLATION</b> <ul style="list-style-type: none"> <li>• Turn ignition key to OFF.</li> <li>• Check for looseness of generator terminal B installation nut.</li> <li>• Is nut loose?</li> </ul>	Yes	Tighten generator terminal B installation nut, then go to Step 6.
		No	Go to next step.
4	<b>INSPECT BATTERY POSITIVE TERMINAL FOR POOR INSTALLATION</b> <ul style="list-style-type: none"> <li>• Check for looseness of battery positive terminal.</li> <li>• Is terminal loose?</li> </ul>	Yes	Connect battery positive terminal correctly, then go to Step 6.
		No	Go to next step.
5	<b>INSPECT BATTERY CHARGING CIRCUIT</b> <ul style="list-style-type: none"> <li>• Start engine.</li> <li>• Disconnect battery positive terminal.</li> <li>• Does engine stall?</li> </ul>	Yes	Repair or replace harness between generator terminal B and battery positive terminal, then go to next step.
		No	Go to next step.
6	<b>VERIFY TROUBLESHOOTING OF DTC P1634 COMPLETED</b> <ul style="list-style-type: none"> <li>• Make sure to reconnect all disconnected connectors.</li> <li>• Clear DTC from PCM memory using WDS or equivalent.</li> <li>• Turn ignition key to OFF, then start engine.</li> <li>• Is same DTC present?</li> </ul>	Yes	Replace PCM, then go to next step.
		No	No concern is detected. Go to next step.
7	<b>VERIFY AFTER REPAIR PROCEDURE</b> <ul style="list-style-type: none"> <li>• Perform "After Repair Procedure".</li> <li>(See 01-02B-9 AFTER REPAIR PROCEDURE [FS].)</li> <li>• Is there any DTC present?</li> </ul>	Yes	Go to applicable DTC inspection. (See 01-02B-15 DTC TABLE [FS].)
		No	Troubleshooting completed.

01-02B

# 01-02C ON-BOARD DIAGNOSTIC [CRUISE CONTROL SYSTEM]

**CRUISE CONTROL SYSTEM**

**WIRING DIAGRAM** ..... 01-02C-1

**FOREWORD** ..... 01-02C-2

Outline ..... 01-02C-2

Inspection Order ..... 01-02C-2

**INSPECTION OF DTCS FOR OPERATION**

**MODE** ..... 01-02C-2

Using The Cruise Set Indicator Light .. 01-02C-2

Using The SST (WDS or equivalent) .. 01-02C-3

Operation Code List ..... 01-02C-3

**DTC 21** ..... 01-02C-4

**DTC 22** ..... 01-02C-4

**DTC 31** ..... 01-02C-4

**DTC 35** ..... 01-02C-6

**DTC 37** ..... 01-02C-7

**INSPECTION OF DTCS FOR CONDITION**

**DETECTION MODE** ..... 01-02C-8

Using The Cruise Set Indicator Light .. 01-02C-8

Using The SST (WDS or equivalent) .. 01-02C-8

Condition Code List ..... 01-02C-8

**DTC 01** ..... 01-02C-9

**DTC 05** ..... 01-02C-10

**DTC 07** ..... 01-02C-10

**DTC 11** ..... 01-02C-11

**DTC 12** ..... 01-02C-11

**DTC 13** ..... 01-02C-12

**DTC 15** ..... 01-02C-12

01-02C

**CRUISE CONTROL SYSTEM WIRING DIAGRAM**

A3U010266350W01

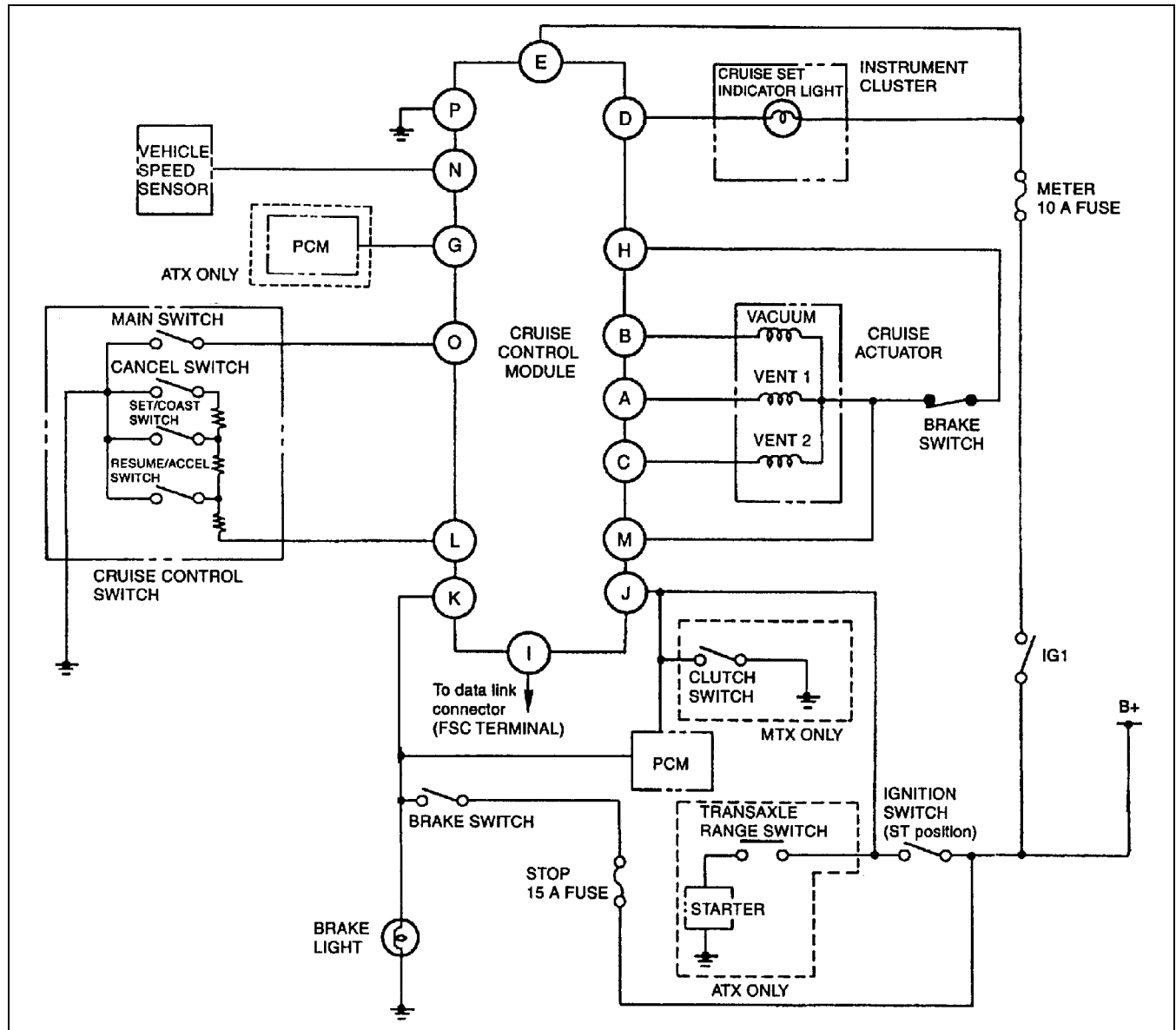

A3U102WY01

# ON-BOARD DIAGNOSTIC [CRUISE CONTROL SYSTEM]

## FOREWORD

A3U010266350W02

### Outline

- There are two on-board diagnostic functions: Operation Mode, which inspects for and indicates correct operation of the input signals to the control module, and Condition Detection Mode, which indicates troubles in the system.
- The two functions can be done by using either of the following methods:
  1. Verifying the flashing pattern of the cruise set indicator light in the instrument cluster.
  2. Verifying the output of the data link connector using the **SST** (WDS or equivalent).

### Inspection Order

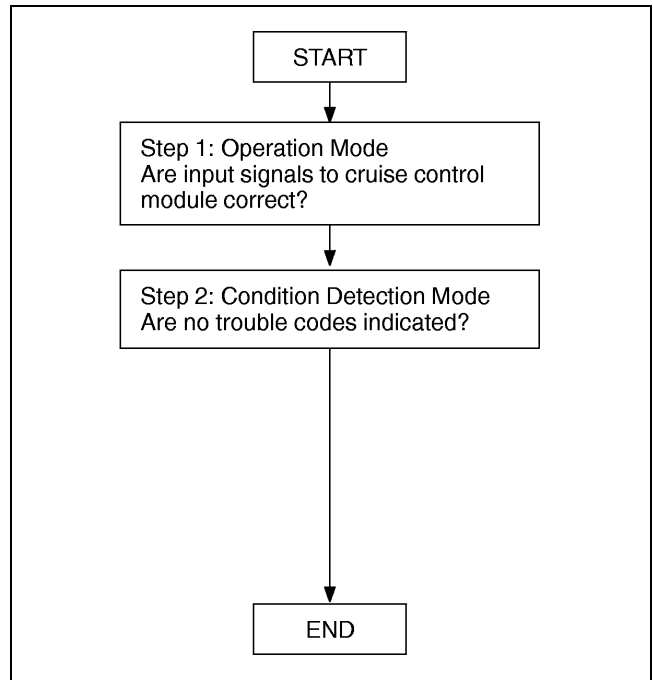

X3U101WPO

## INSPECTION OF DTCS FOR OPERATION MODE

A3U010266350W03

### Note

- If an Operation Mode is not indicated, the following may be the cause of the malfunction.
  1. Cruise control switch (RESUME/ACCEL switch)
  2. Cruise control main switch
  3. Cruise control module
  4. Open or short circuit in wiring harness

### Using The Cruise Set Indicator Light

1. Turn the ignition switch to the ON position.
2. Verify that the cruise control main switch is off.
3. Perform the following steps to activate the operation mode.
  - (1) Push up the cruise control switch and hold it in the RESUME/ACCEL position.
  - (2) Turn on the cruise control main switch.
  - (3) Hold the cruise control switch in the RESUME/ACCEL position for **at least 3 seconds**. (The cruise set indicator light will illuminate for **3 seconds**.)
4. Operate each switch as described in the operation code list and note the operation code list pattern.
  - If the cruise set indicator light does not flash, inspect the corresponding system area.
5. The operation mode is canceled by turning the ignition switch to LOCK position or turning off the cruise control main switch.

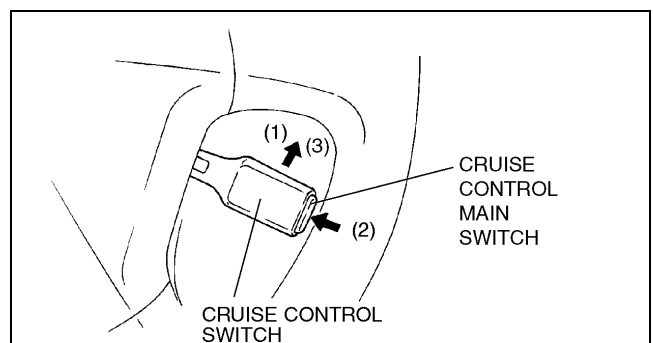

Y3U102WYA

# ON-BOARD DIAGNOSTIC [CRUISE CONTROL SYSTEM]

## Using The SST (WDS or equivalent) DTCs retrieving procedure

1. Hook-up the **SST** to the vehicle. Make sure that ignition key is at LOCK and all accessories are OFF.
2. Turn the ignition key to ON (engine OFF).
3. Retrieve any DTCs by WDS or equivalent.

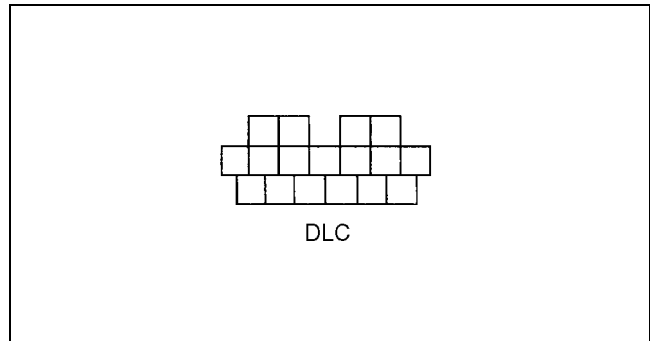

01-02C

Z3U0102W401

## Operation Code List

Operation		DTC	Output pattern	Diagnosed circuit	
Turn SET/COAST switch on		21		Cruise control switch (SET/COAST switch)	
Turn RESUME/ACCEL switch on		22		Cruise control switch (RESUME/ACCEL switch)	
Depress brake pedal		31		Brake switch	
ATX	Shift selector lever to P or N range	35		ATX	Transaxle range switch
MTX	Depress clutch pedal			MTX	Clutch switch
Drive vehicle above 40 km/h {25 mph}		37		Vehicle speed sensor	

# ON-BOARD DIAGNOSTIC [CRUISE CONTROL SYSTEM]

## DTC 21

A3U010266350W04

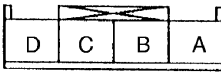
<b>DTC 21</b>	<b>Cruise control switch (set/coast switch)</b>
<b>DETECTION CONDITION</b>	<ul style="list-style-type: none"> <li>Resistance detected between terminal L and ground is other than <b>approximately 198 ohms</b>.</li> </ul>
<b>POSSIBLE CAUSE</b>	<ul style="list-style-type: none"> <li>Cruise control module malfunction</li> <li>Cruise control switch malfunction</li> </ul>
<p>CLOCK SPRING CONNECTOR</p>  <p>HARNESS SIDE CONNECTOR (VIEW FROM HARNESS SIDE)</p>	

### Diagnostic procedure

INSPECTION	ACTION	
<b>INSPECT SIGNAL LINE OF CRUISE CONTROL SWITCH POSITION</b> <ul style="list-style-type: none"> <li>Remove column cover.</li> <li>Turn ignition switch to ON position.</li> <li>Turn cruise control main switch on.</li> <li>Turn SET/COAST switch on.</li> <li>Is voltage at terminal C of clock spring connector <b>approximately 2 V</b>?</li> </ul>	Yes	Replace cruise control module. (See 01-20-2 CRUISE CONTROL MODULE REMOVAL/INSTALLATION)
	No	Replace cruise control switch. (See 01-20-7 CRUISE CONTROL SWITCH REMOVAL/INSTALLATION)

## DTC 22

A3U010266350W05

<b>DTC 22</b>	<b>Cruise control switch (resume/accel switch)</b>
<b>DETECTION CONDITION</b>	<ul style="list-style-type: none"> <li>Resistance detected between terminal L and ground is other than <b>68 ohms</b>.</li> </ul>
<b>POSSIBLE CAUSE</b>	<ul style="list-style-type: none"> <li>Cruise control module malfunction</li> </ul>

### Diagnostic procedure

ACTION
Replace cruise control module. (See 01-20-2 CRUISE CONTROL MODULE REMOVAL/INSTALLATION)

## DTC 31

A3U010266350W06

<b>DTC 31</b>	<b>Brake switch</b>
<b>DETECTION CONDITION</b>	<ul style="list-style-type: none"> <li>Voltage detected at terminal K is not <b>approximately 12 V</b> or voltage detected at terminal M is not <b>approximately 0 V</b>.</li> </ul>
<b>POSSIBLE CAUSE</b>	<ul style="list-style-type: none"> <li>Burnt STOP 15 A fuse</li> <li>Cruise control module malfunction</li> <li>Brake switch malfunction</li> <li>Open circuit in wiring harness between STOP 15 A fuse and brake switch</li> <li>Open circuit in wiring harness between brake switch and cruise control module</li> </ul>

BRAKE SWITCH CONNECTOR



HARNESS SIDE CONNECTOR  
(VIEW FROM HARNESS SIDE)

CRUISE CONTROL MODULE CONNECTOR

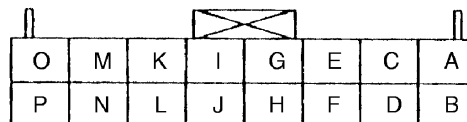

HARNESS SIDE CONNECTOR  
(VIEW FROM HARNESS SIDE)

## ON-BOARD DIAGNOSTIC [CRUISE CONTROL SYSTEM]

### Diagnostic procedure

STEP	INSPECTION	ACTION	
1	<b>VERIFY WHICH MALFUNCTION IS, ONE BRAKE SWITCH CIRCUIT OR ANOTHER</b> <ul style="list-style-type: none"> <li>• Does brake light illuminate when brake pedal depressed?</li> </ul>	Yes	Go to Step 6.
		No	Go to next step.
2	<b>INSPECT STOP 15 A FUSE FOR FUSION</b> <ul style="list-style-type: none"> <li>• Is STOP 15 A fuse okay?</li> </ul>	Yes	Go to next step.
		No	Replace fuse after inspecting and repairing wiring harness.
3	<b>INSPECT WIRING HARNESS BETWEEN STOP 15 A FUSE AND BRAKE SWITCH FOR CONTINUITY</b> <ul style="list-style-type: none"> <li>• Depress brake pedal.</li> <li>• Is voltage at terminal 1B of brake switch connector <b>approximately 12 V</b>?</li> </ul>	Yes	Go to Step 5.
		No	Go to next step.
4	<b>INSPECT WIRING HARNESS BETWEEN STOP 15 A FUSE AND BRAKE SWITCH FOR CONTINUITY</b> <ul style="list-style-type: none"> <li>• Is voltage at terminal 1A of brake switch connector <b>approximately 12 V</b>?</li> </ul>	Yes	Replace brake switch. (See 04-11-5 BRAKE PEDAL REMOVAL/INSTALLATION)
		No	Repair wiring harness. (STOP 15 A fuse—Brake switch)
5	<b>INSPECT WIRING HARNESS BETWEEN BRAKE SWITCH AND CRUISE CONTROL MODULE FOR CONTINUITY</b> <ul style="list-style-type: none"> <li>• Remove passenger-side front side trim. (See 09-17-13 FRONT SIDE TRIM REMOVAL/INSTALLATION)</li> <li>• Depress brake pedal.</li> <li>• Is voltage at terminal K of cruise control module connector <b>approximately 12 V</b>?</li> </ul>	Yes	Replace cruise control module. (See 01-20-2 CRUISE CONTROL MODULE REMOVAL/INSTALLATION)
		No	Repair wiring harness. (Cruise control module—Brake switch)
6	<b>INSPECT WIRING HARNESS BETWEEN BRAKE SWITCH AND CRUISE CONTROL MODULE FOR CONTINUITY</b> <ul style="list-style-type: none"> <li>• Remove passenger-side front side trim. (See 09-17-13 FRONT SIDE TRIM REMOVAL/INSTALLATION)</li> <li>• Depress brake pedal.</li> <li>• Is voltage at terminal K of cruise control module connector <b>approximately 12 V</b>?</li> </ul>	Yes	Go to next step.
		No	Repair wiring harness. (Cruise control module—Brake switch)
7	<b>INSPECT BRAKE SWITCH</b> <ul style="list-style-type: none"> <li>• Turn ignition switch to ON position.</li> <li>• Turn cruise control main switch on.</li> <li>• Depress brake pedal.</li> <li>• Is voltage at terminal M of cruise control module connector <b>approximately 0 V</b>?</li> </ul>	Yes	Replace cruise control module. (See 01-20-2 CRUISE CONTROL MODULE REMOVAL/INSTALLATION)
		No	Replace brake switch. (See 04-11-5 BRAKE PEDAL REMOVAL/INSTALLATION)

01-02C



# ON-BOARD DIAGNOSTIC [CRUISE CONTROL SYSTEM]

DTC 35

A3U010266350W07

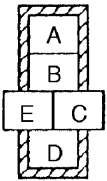
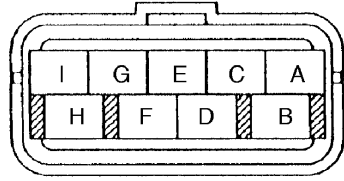
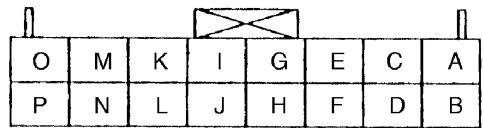
<b>DTC 35</b>	<b>Clutch switch (ATX: transaxle range switch)</b>	
<b>DETECTION CONDITION</b>	<ul style="list-style-type: none"> <li>• Voltage detected at terminal J is not <b>approximately 0 V</b>.</li> </ul>	
<b>POSSIBLE CAUSE</b>	<ul style="list-style-type: none"> <li>• Cruise control module malfunction</li> <li>• Clutch switch malfunction (ATX: transaxle range switch)</li> <li>• Open circuit in wiring harness between clutch switch (ATX: transaxle range switch) and ground</li> <li>• Open circuit in wiring harness between clutch switch (ATX: transaxle range switch) and cruise control module</li> </ul>	
<div style="display: flex; justify-content: space-around; align-items: flex-start;"> <div style="text-align: center;"> <p>CLUTCH SWITCH CONNECTOR</p>  <p>HARNESS SIDE CONNECTOR (VIEW FROM HARNESS SIDE)</p> </div> <div style="text-align: center;"> <p>TRANSAXLE RANGE SWITCH CONNECTOR</p>  <p>HARNESS SIDE CONNECTOR (VIEW FROM HARNESS SIDE)</p> </div> <div style="text-align: center;"> <p>CRUISE CONTROL MODULE CONNECTOR</p>  <p>HARNESS SIDE CONNECTOR (VIEW FROM HARNESS SIDE)</p> </div> </div>		

### Diagnostic procedure

STEP	INSPECTION		ACTION
1	<ul style="list-style-type: none"> <li>• Does vehicle has MTX?</li> </ul>	Yes	Go to next step.
		No	Go to Step 6.
2	<ul style="list-style-type: none"> <li>• Inspect clutch switch. (See 01-40A-41 CLUTCH SWITCH INSPECTION [ZM])</li> <li>• (See 01-40B-42 CLUTCH SWITCH INSPECTION [FS])</li> <li>• Is clutch switch okay?</li> </ul>	Yes	Go to next step.
		No	Replace clutch switch. (See 05-10-5 CLUTCH PEDAL REMOVAL/INSTALLATION)
3	<p><b>INSPECT WIRING HARNESS BETWEEN CLUTCH SWITCH AND GROUND FOR CONTINUITY</b></p> <ul style="list-style-type: none"> <li>• Disconnect clutch switch connector.</li> <li>• Is there continuity between terminal E of clutch switch connector and ground?</li> </ul>	Yes	Go to next step.
		No	Repair wiring harness. (Clutch switch—GND)
4	<p><b>INSPECT WIRING HARNESS BETWEEN CLUTCH SWITCH AND CRUISE CONTROL MODULE FOR CONTINUITY</b></p> <ul style="list-style-type: none"> <li>• Turn ignition switch to ON position.</li> <li>• Turn cruise control main switch on.</li> <li>• Keep clutch pedal released.</li> <li>• Is voltage at terminal C of clutch switch connector <b>approximately 12 V</b>?</li> </ul>	Yes	Replace cruise control module. (See 01-20-2 CRUISE CONTROL MODULE REMOVAL/INSTALLATION)
		No	Go to next step.
5	<p><b>INSPECT CRUISE CONTROL MODULE</b></p> <ul style="list-style-type: none"> <li>• Remove passenger-side front side trim. (See 09-17-13 FRONT SIDE TRIM REMOVAL/INSTALLATION)</li> <li>• Is voltage at terminal J of cruise control module connector <b>approximately 12 V</b>?</li> </ul>	Yes	Repair wiring harness. (Cruise control module—Clutch switch)
		No	Replace cruise control module. (See 01-20-2 CRUISE CONTROL MODULE REMOVAL/INSTALLATION)
6	<ul style="list-style-type: none"> <li>• Inspect transaxle range switch. (See 05-17-20 TRANSAXLE RANGE (TR) SWITCH INSPECTION)</li> <li>• Is transaxle range switch okay?</li> </ul>	Yes	Go to next step.
		No	Replace transaxle range switch. (See 05-17-20 TRANSAXLE RANGE (TR) SWITCH REMOVAL/INSTALLATION)
7	<p><b>INSPECT WIRING HARNESS BETWEEN TRANSAXLE RANGE SWITCH AND GROUND FOR CONTINUITY</b></p> <ul style="list-style-type: none"> <li>• Disconnect transaxle range switch connector.</li> <li>• Is there continuity between terminal B of transaxle range switch connector and ground?</li> </ul>	Yes	Go to next step.
		No	Repair wiring harness. (Transaxle range switch—GND)

## ON-BOARD DIAGNOSTIC [CRUISE CONTROL SYSTEM]

STEP	INSPECTION	ACTION
8	<b>INSPECT WIRING HARNESS BETWEEN TRANSAXLE RANGE SWITCH AND CRUISE CONTROL MODULE FOR CONTINUITY</b> <ul style="list-style-type: none"> <li>Turn ignition switch to ON position.</li> <li>Turn cruise control main switch on.</li> <li>Shift selector lever to D or R range.</li> <li>Is voltage at terminal H of transaxle range switch connector <b>approximately 12 V</b>?</li> </ul>	Yes Replace cruise control module. (See 01-20-2 CRUISE CONTROL MODULE REMOVAL/INSTALLATION)
		No Go to next step.
9	<b>INSPECT CRUISE CONTROL MODULE</b> <ul style="list-style-type: none"> <li>Remove passenger-side front side trim. (See 09-17-13 FRONT SIDE TRIM REMOVAL/INSTALLATION)</li> <li>Is voltage at terminal J of cruise control module connector <b>approximately 12 V</b>?</li> </ul>	Yes Repair wiring harness. (Cruise control module—Transaxle range switch)
		No Replace cruise control module. (See 01-20-2 CRUISE CONTROL MODULE REMOVAL/INSTALLATION)

01-02C

### DTC 37

A3U010266350W08

DTC 37	Vehicle speed sensor
<b>DETECTION CONDITION</b>	<ul style="list-style-type: none"> <li>Voltage detected at terminal N does not <b>alternate between 0 V and 5 V</b>.</li> </ul>
<b>POSSIBLE CAUSE</b>	<ul style="list-style-type: none"> <li>Cruise control module malfunction</li> <li>Instrument cluster malfunction</li> <li>Open circuit in wiring harness between instrument cluster and cruise control module</li> </ul>
<div style="display: flex; justify-content: space-around;"> <div style="text-align: center;"> <p>INSTRUMENT CLUSTER CONNECTOR</p> <p>HARNESS SIDE CONNECTOR (VIEW FROM HARNESS SIDE)</p> </div> <div style="text-align: center;"> <p>CRUISE CONTROL MODULE CONNECTOR</p> <p>HARNESS SIDE CONNECTOR (VIEW FROM HARNESS SIDE)</p> </div> </div>	

### Diagnostic procedure

STEP	INSPECTION	ACTION
1	<b>INSPECT WIRING HARNESS BETWEEN INSTRUMENT CLUSTER AND CRUISE CONTROL MODULE FOR CONTINUITY</b> <ul style="list-style-type: none"> <li>Remove instrument cluster. (See 09-22-3 INSTRUMENT CLUSTER REMOVAL/INSTALLATION)</li> <li>Remove passenger-side front side trim. (See 09-17-13 FRONT SIDE TRIM REMOVAL/INSTALLATION)</li> <li>Disconnect cruise control module connector.</li> <li>Is there continuity between terminal N of cruise control module connector and terminal 3T of instrument cluster connector?</li> </ul>	Yes Go to next step.
		No Repair wiring harness. (Cruise control module—instrument cluster)
2	<b>INSPECT VEHICLE SPEED SIGNAL</b> <ul style="list-style-type: none"> <li>Turn ignition switch to ON position.</li> <li>Turn cruise control main switch on.</li> <li>Rotate front tires.</li> <li>Does voltage at terminal 3T of instrument cluster connector <b>alternate between 0 V and 5 V</b>?</li> </ul>	Yes Replace cruise control module. (See 01-20-2 CRUISE CONTROL MODULE REMOVAL/INSTALLATION)
		No Replace instrument cluster. (See 09-22-3 INSTRUMENT CLUSTER REMOVAL/INSTALLATION)

# ON-BOARD DIAGNOSTIC [CRUISE CONTROL SYSTEM]

## INSPECTION OF DTCS FOR CONDITION DETECTION MODE

A3U010266350W09

### Using The Cruise Set Indicator Light

**Note**

- If the RESUME/ACCEL switch on the cruise control switch is malfunctioning, the cruise set indicator light will not give a correct indication when you inspect the system. Use the **SST** (WDS or equivalent) to determine the cause of the malfunction.

1. Drive the vehicle at **over 16 km/h {10 mph}**.
2. Operate each of the cruise control switches.
3. Stop the vehicle and let it idle.
4. The following steps to activate the detection mode.
  - (1) Turn on the cruise control main switch.
  - (2) Push up the cruise control switch and hold it in the RESUME/ACCEL position for **at least 3 seconds**. (The cruise set indicator light will illuminate for **3 seconds**.)
    - If a DTC is indicated, inspect the corresponding system area.
5. The condition detection mode is canceled by turning the ignition switch to LOCK position or turning off the cruise control main switch.

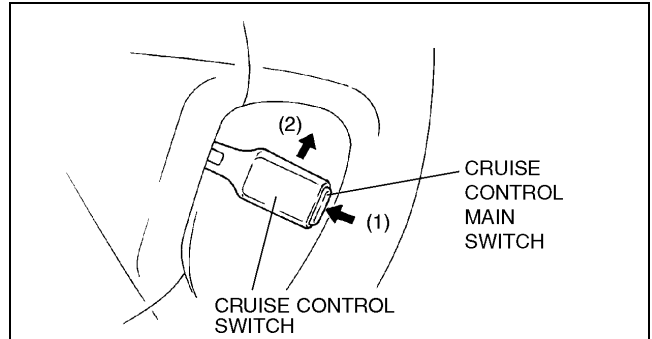

Y3U102WYB

### Using The SST (WDS or equivalent) DTCs retrieving procedure

1. Hook-up the **SST** to the vehicle. Make sure that ignition key is at LOCK and all accessories are OFF.
2. Turn the ignition key to ON (engine OFF).
3. Retrieve any DTCs by WDS or equivalent.

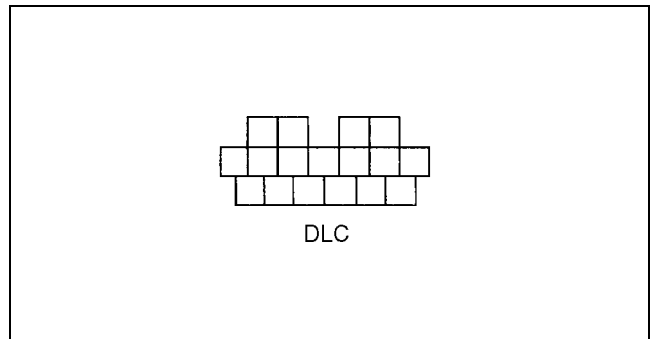



Z3U0102W401

### Condition Code List

DTC	Output pattern	Diagnosed circuit
01		Cruise actuator
05		Brake switch
07		Brake switch
11		Cruise control switch (SET/COAST switch)
12		Cruise control switch (RESUME/ACCEL switch)

# ON-BOARD DIAGNOSTIC [CRUISE CONTROL SYSTEM]

DTC	Output pattern	Diagnosed circuit
13		Cruise control switch (Ground circuit)
15		Cruise control module

01-02C

**Note**

- When two or more DTCs are indicated, inspect the malfunction with the smallest number first.

**DTC 01**

A3U010266350W10

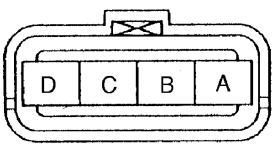
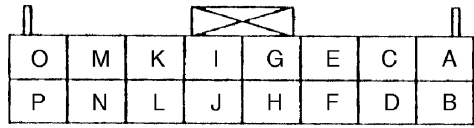
DTC 01	Cruise actuator
<b>DETECTION CONDITION</b>	<ul style="list-style-type: none"> <li>• Voltages detected at terminal A, B or C are not <b>approximately 12 V</b>.</li> </ul>
<b>POSSIBLE CAUSE</b>	<ul style="list-style-type: none"> <li>• Cruise control module malfunction</li> <li>• Cruise actuator malfunction</li> <li>• Open circuit in wiring harness between cruise control module and cruise actuator</li> <li>• Open circuit in wiring harness between cruise actuator and brake switch</li> <li>• Open circuit in wiring harness between cruise control module and brake switch</li> </ul>
<div style="display: flex; justify-content: space-around;"> <div style="text-align: center;"> <p>CRUISE ACTUATOR CONNECTOR</p>  <p>HARNESS SIDE CONNECTOR (VIEW FROM HARNESS SIDE)</p> </div> <div style="text-align: center;"> <p>CRUISE CONTROL MODULE CONNECTOR</p>  <p>HARNESS SIDE CONNECTOR (VIEW FROM HARNESS SIDE)</p> </div> </div>	

**Diagnostic procedure**

STEP	INSPECTION	ACTION
1	<b>INSPECT WIRING HARNESS BETWEEN CRUISE CONTROL MODULE AND CRUISE ACTUATOR FOR CONTINUITY</b> <ul style="list-style-type: none"> <li>• Are wiring harnesses between cruise control module and cruise actuator okay?</li> </ul>	Yes Go to next step.
		No Repair wiring harness. (Cruise control module—Cruise actuator)
2	<b>INSPECT POWER SUPPLY LINE OF CRUISE ACTUATOR</b> <ul style="list-style-type: none"> <li>• Disconnect cruise actuator connector.</li> <li>• Turn ignition switch to ON position.</li> <li>• Turn cruise control main switch on.</li> <li>• Is voltage at terminal B of cruise actuator connector <b>approximately 12 V</b>?</li> </ul>	Yes Go to Step 6.
		No Go to next step.
3	<b>INSPECT WIRING HARNESS BETWEEN BRAKE SWITCH AND CRUISE ACTUATOR FOR CONTINUITY</b> <ul style="list-style-type: none"> <li>• Is voltage at terminal 2B of brake switch connector <b>approximately 12 V</b>?</li> </ul>	Yes Repair wiring harness. (Cruise actuator—Brake switch)
		No Go to next step.
4	<b>INSPECT BRAKE SWITCH</b> <ul style="list-style-type: none"> <li>• Is voltage at terminal 2A of brake switch connector <b>approximately 12 V</b>?</li> </ul>	Yes Replace brake switch. (See 04-11-5 BRAKE PEDAL REMOVAL/INSTALLATION)
		No Go to next step.
5	<b>INSPECT CRUISE CONTROL MODULE</b> <ul style="list-style-type: none"> <li>• Remove passenger-side front side trim. (See 09-17-13 FRONT SIDE TRIM REMOVAL/INSTALLATION)</li> <li>• Is voltage at terminal H of cruise control module connector <b>approximately 12 V</b>?</li> </ul>	Yes Repair wiring harness. (Cruise control module—Brake switch)
		No Replace cruise control module. (See 01-20-2 CRUISE CONTROL MODULE REMOVAL/INSTALLATION)

# ON-BOARD DIAGNOSTIC [CRUISE CONTROL SYSTEM]

STEP	INSPECTION	ACTION	
6	<b>INSPECT CRUISE ACTUATOR</b> <ul style="list-style-type: none"> <li>Connect cruise actuator connector.</li> <li>Turn ignition switch to ON position.</li> <li>Turn cruise control main switch on.</li> <li>Is voltage at terminal D of cruise actuator connector <b>approximately 12 V</b>?</li> </ul>	Yes	Go to next step.
		No	Replace cruise actuator. (See 01-20-4 CRUISE ACTUATOR REMOVAL/INSTALLATION)
7	<b>INSPECT CRUISE ACTUATOR</b> <ul style="list-style-type: none"> <li>Is voltage at terminal A of cruise actuator connector <b>approximately 12 V</b>?</li> </ul>	Yes	Go to next step.
		No	Replace cruise actuator. (See 01-20-4 CRUISE ACTUATOR REMOVAL/INSTALLATION)
8	<b>INSPECT CRUISE ACTUATOR</b> <ul style="list-style-type: none"> <li>Is voltage at terminal C of cruise actuator connector <b>approximately 12 V</b>?</li> </ul>	Yes	Replace cruise control module. (See 01-20-2 CRUISE CONTROL MODULE REMOVAL/INSTALLATION)
		No	Replace cruise actuator. (See 01-20-4 CRUISE ACTUATOR REMOVAL/INSTALLATION)

## DTC 05

A3U010266350W11

DTC 05	Brake switch
<b>DETECTION CONDITION</b>	<ul style="list-style-type: none"> <li>Voltage detected at terminal K is always <b>approximately 0 V</b>.</li> </ul>
<b>POSSIBLE CAUSE</b>	<ul style="list-style-type: none"> <li>Cruise control module malfunction</li> </ul>

### Diagnostic procedure

INSPECTION	ACTION	
<ul style="list-style-type: none"> <li>Was operation mode performed?</li> </ul>	Yes	Perform operation mode on-board diagnostic again. Even if no malfunctions are detected in operation mode, if DTC 05 is indicated in condition detection mode on-board diagnostic, replace cruise control module. (See 01-20-2 CRUISE CONTROL MODULE REMOVAL/INSTALLATION)
	No	Perform operation mode.

## DTC 07

A3U010266350W12

DTC 07	Brake switch
<b>DETECTION CONDITION</b>	<ul style="list-style-type: none"> <li>Voltage detected at terminal K or M is always <b>approximately 12 V</b>.</li> <li>Voltage detected at terminal M is always <b>approximately 0 V</b>.</li> </ul>
<b>POSSIBLE CAUSE</b>	<ul style="list-style-type: none"> <li>Cruise control module malfunction</li> <li>Brake switch malfunction</li> <li>Open circuit in wiring harness between cruise control module and brake switch</li> </ul>

BRAKE SWITCH CONNECTOR

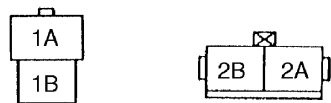

HARNESS SIDE CONNECTOR  
(VIEW FROM HARNESS SIDE)

CRUISE CONTROL MODULE CONNECTOR

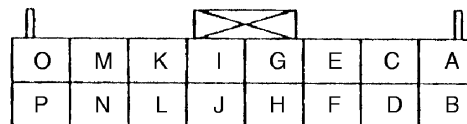

HARNESS SIDE CONNECTOR  
(VIEW FROM HARNESS SIDE)

# ON-BOARD DIAGNOSTIC [CRUISE CONTROL SYSTEM]

## Diagnostic procedure

STEP	INSPECTION	ACTION	
1	<ul style="list-style-type: none"> <li>• Disconnect brake switch connector.</li> <li>• Is there continuity between terminal 1A and 1B of brake switch?</li> </ul>	Yes	Replace brake switch. (See 04-11-5 BRAKE PEDAL REMOVAL/INSTALLATION)
		No	Go to next step.
2	<ul style="list-style-type: none"> <li>• Remove passenger-side front side trim. (See 09-17-13 FRONT SIDE TRIM REMOVAL/INSTALLATION)</li> <li>• Turn ignition switch to ON position.</li> <li>• Turn cruise control main switch on.</li> <li>• Depress brake pedal.</li> <li>• Is voltage at terminal M of cruise control module connector <b>approximately 0 V</b>?</li> </ul>	Yes	Repair wiring harness. (Cruise control module—Brake switch)
		No	Replace cruise control module. (See 01-20-2 CRUISE CONTROL MODULE REMOVAL/INSTALLATION)

01-02C

## DTC 11

A3U010266350W13

DTC 11	Cruise control switch (set/coast switch)
<b>DETECTION CONDITION</b>	<ul style="list-style-type: none"> <li>• Resistance detected between terminal L and ground is always <b>approximately 198 ohms</b>.</li> </ul>
<b>POSSIBLE CAUSE</b>	<ul style="list-style-type: none"> <li>• Cruise control module malfunction</li> </ul>

## Diagnostic procedure

INSPECTION	ACTION				
<ul style="list-style-type: none"> <li>• Was operation mode performed?</li> </ul>	<table border="1" style="width: 100%; border-collapse: collapse;"> <tr> <td style="text-align: center; width: 10%;">Yes</td> <td>Perform operation mode on-board diagnostic again. Even if no malfunctions are detected in operation mode, if DTC 11 is indicated in condition detection mode on-board diagnostic, replace cruise control module. (See 01-20-2 CRUISE CONTROL MODULE REMOVAL/INSTALLATION)</td> </tr> <tr> <td style="text-align: center;">No</td> <td>Perform operation mode.</td> </tr> </table>	Yes	Perform operation mode on-board diagnostic again. Even if no malfunctions are detected in operation mode, if DTC 11 is indicated in condition detection mode on-board diagnostic, replace cruise control module. (See 01-20-2 CRUISE CONTROL MODULE REMOVAL/INSTALLATION)	No	Perform operation mode.
Yes	Perform operation mode on-board diagnostic again. Even if no malfunctions are detected in operation mode, if DTC 11 is indicated in condition detection mode on-board diagnostic, replace cruise control module. (See 01-20-2 CRUISE CONTROL MODULE REMOVAL/INSTALLATION)				
No	Perform operation mode.				

## DTC 12

A3U010266350W14

DTC 12	Cruise control switch (resume/accel switch)
<b>DETECTION CONDITION</b>	<ul style="list-style-type: none"> <li>• Resistance detected between terminal L and ground is always <b>approximately 68 ohms</b>.</li> </ul>
<b>POSSIBLE CAUSE</b>	<ul style="list-style-type: none"> <li>• Cruise control module malfunction</li> </ul>

## Diagnostic procedure

INSPECTION	ACTION				
<ul style="list-style-type: none"> <li>• Was operation mode performed?</li> </ul>	<table border="1" style="width: 100%; border-collapse: collapse;"> <tr> <td style="text-align: center; width: 10%;">Yes</td> <td>Perform operation mode on-board diagnostic again. Even if no malfunctions are detected in operation mode, if DTC 12 is indicated in condition detection mode on-board diagnostic, replace cruise control module. (See 01-20-2 CRUISE CONTROL MODULE REMOVAL/INSTALLATION)</td> </tr> <tr> <td style="text-align: center;">No</td> <td>Perform operation mode.</td> </tr> </table>	Yes	Perform operation mode on-board diagnostic again. Even if no malfunctions are detected in operation mode, if DTC 12 is indicated in condition detection mode on-board diagnostic, replace cruise control module. (See 01-20-2 CRUISE CONTROL MODULE REMOVAL/INSTALLATION)	No	Perform operation mode.
Yes	Perform operation mode on-board diagnostic again. Even if no malfunctions are detected in operation mode, if DTC 12 is indicated in condition detection mode on-board diagnostic, replace cruise control module. (See 01-20-2 CRUISE CONTROL MODULE REMOVAL/INSTALLATION)				
No	Perform operation mode.				

# ON-BOARD DIAGNOSTIC [CRUISE CONTROL SYSTEM]

## DTC 13

A3U010266350W15

<b>DTC 13</b>	<b>Cruise control switch (ground circuit)</b>
<b>DETECTION CONDITION</b>	<ul style="list-style-type: none"><li>Resistance detected between terminal L and ground is always <b>approximately 0 ohm</b>.</li></ul>
<b>POSSIBLE CAUSE</b>	<ul style="list-style-type: none"><li>Cruise control module malfunction</li></ul>

### Diagnostic procedure

INSPECTION		ACTION
<ul style="list-style-type: none"><li>Was operation mode performed?</li></ul>	Yes	Perform operation mode on-board diagnostic again. Even if no malfunctions are detected in operation mode, if DTC 13 is indicated in condition detection mode on-board diagnostic, replace cruise control module. (See 01-20-2 CRUISE CONTROL MODULE REMOVAL/INSTALLATION)
	No	Perform operation mode.

## DTC 15

A3U010266350W16

<b>DTC 15</b>	<b>Cruise control module</b>
<b>DETECTION CONDITION</b>	<ul style="list-style-type: none"><li>Malfunction in cruise control module circuit</li></ul>
<b>POSSIBLE CAUSE</b>	<ul style="list-style-type: none"><li>Cruise control module malfunction</li></ul>

### Diagnostic procedure

ACTION
Replace cruise control module. (See 01-20-2 CRUISE CONTROL MODULE REMOVAL/INSTALLATION)

# 01-03A SYMPTOM TROUBLESHOOTING [ENGINE CONTROL SYSTEM (ZM)]

<b>CONTROL SYSTEM DEVICE AND RELATIONSHIP CHART [ZM]</b> . . . . .	01-03A-2	<b>NO.18 COOLING SYSTEM CONCERNS-RUNS COLD [ZM]</b> . . . . .	01-03A-40
Engine Control System . . . . .	01-03A-2	<b>NO.19 EXHAUST SMOKE [ZM]</b> . . . . .	01-03A-41
<b>FOREWORD [ZM]</b> . . . . .	01-03A-4	<b>NO.20 FUEL ODOR (IN ENGINE COMPARTMENT) [ZM]</b> . . . . .	01-03A-43
<b>INTERMITTENT CONCERN TROUBLESHOOTING [ZM]</b> . . . . .	01-03A-4	<b>NO.21 ENGINE NOISE [ZM]</b> . . . . .	01-03A-44
Vibration Method . . . . .	01-03A-4	<b>NO.22 VIBRATION CONCERNS (ENGINE) [ZM]</b> . . . . .	01-03A-45
Water Sprinkling Method . . . . .	01-03A-6	<b>NO.23 A/C DOES NOT WORK SUFFICIENTLY [ZM]</b> . . . . .	01-03A-45
<b>SYMPTOM DIAGNOSTIC INDEX [ZM]</b> . . . . .	01-03A-7	<b>NO.24 A/C IS ALWAYS ON/A/C COMPRESSOR RUNS CONTINUOUSLY [ZM]</b> . . . . .	01-03A-46
<b>SYMPTOM QUICK DIAGNOSIS CHART [ZM]</b> . . . . .	01-03A-9	<b>NO.25 A/C DOES NOT CUT OFF UNDER WIDE OPEN THROTTLE CONDITIONS [ZM]</b> . . . . .	01-03A-47
<b>NO.1 MELTING OF MAIN OR OTHER FUSES [ZM]</b> . . . . .	01-03A-13	<b>NO.26 EXHAUST SULPHUR SMELL [ZM]</b> . . . . .	01-03A-47
<b>NO.2 MIL ILLUMINATES [ZM]</b> . . . . .	01-03A-14	<b>NO.27 FUEL REFILL CONCERNS [ZM]</b> . . . . .	01-03A-48
<b>NO.3 WILL NOT CRANK [ZM]</b> . . . . .	01-03A-14	<b>NO.28 FUEL FILLING SHUT OFF ISSUES [ZM]</b> . . . . .	01-03A-49
<b>NO.4 HARD TO START/LONG CRANK/ERRATIC START/ERRATIC CRANK [ZM]</b> . . . . .	01-03A-15	<b>NO.29 INTERMITTENT CONCERNS [ZM]</b> . . . . .	01-03A-49
<b>NO.5 ENGINE STALLS-AFTER START/AT IDLE [ZM]</b> . . . . .	01-03A-18	<b>NO.30 CONSTANT VOLTAGE [ZM]</b> . . . . .	01-03A-50
<b>NO.6 CRANKS NORMALLY BUT WILL NOT START [ZM]</b> . . . . .	01-03A-21	<b>NO.31 SPARK PLUG CONDITION [ZM]</b> . . . . .	01-03A-52
<b>NO.7 SLOW RETURN TO IDLE [ZM]</b> . . . . .	01-03A-24	<b>ENGINE CONTROL SYSTEM OPERATION INSPECTION [ZM]</b> . . . . .	01-03A-55
<b>NO.8 ENGINE RUNS ROUGH/ROLLING IDLE [ZM]</b> . . . . .	01-03A-25	Evaporative System Leak Inspection Using Leak Tester. . . . .	01-03A-55
<b>NO.9 FAST IDLE/RUNS ON [ZM]</b> . . . . .	01-03A-27	Evaporative System Leak Inspection Using Vacuum Pump . . . . .	01-03A-56
<b>NO.10 LOW IDLE/STALLS DURING DECELERATION [ZM]</b> . . . . .	01-03A-28	Main Relay Operation Inspection . . . . .	01-03A-56
<b>NO.11 ENGINE STALLS/QUITS, ENGINE RUNS ROUGH, MISSES, BUCK/JERK, HESITATION/STUMBLE, SURGES [ZM]</b> . . . . .	01-03A-29	Intake Manifold Vacuum Inspection . . . . .	01-03A-57
<b>NO.12 LACK/LOSS OF POWER-ACCELERATION/CRUISE [ZM]</b> . . . . .	01-03A-32	Idle Air Control (IAC) Inspection . . . . .	01-03A-57
<b>NO.13 KNOCKING/PINGING-ACCELERATION/CRUISE [ZM]</b> . . . . .	01-03A-34	Variable Tumble Control System (VTCS) Inspection. . . . .	01-03A-58
<b>NO.14 POOR FUEL ECONOMY [ZM]</b> . . . . .	01-03A-35	Pressure Regulator Control Inspection . . . . .	01-03A-59
<b>NO.15 EMISSION COMPLIANCE [ZM]</b> . . . . .	01-03A-37	Fuel Injector Operation Inspection . . . . .	01-03A-60
<b>NO.16 HIGH OIL CONSUMPTION/LEAKAGE [ZM]</b> . . . . .	01-03A-38	Spark Test. . . . .	01-03A-60
<b>NO.17 COOLING SYSTEM CONCERNS-OVERHEATING [ZM]</b> . . . . .	01-03A-39		

**01-03A**



# SYMPTOM TROUBLESHOOTING [ENGINE CONTROL SYSTEM (ZM)]

## CONTROL SYSTEM DEVICE AND RELATIONSHIP CHART [ZM]

A3U010318881W38

### Engine Control System

x :Applied

Component	Idle air control (IAC)	Fuel injection control	Pressure regulator control(PRC)	Electronic spark advance (ESA) control	Fuel pump control	Front heated oxygen sensor (HO2S) heater control	Rear heated oxygen sensor (HO2S) heater control	Electric fan control	Purge control	EGR control	Variable tumble control system (VTCS)	A/C cut-out control	Generator control
<b>Input</b>													
Brake switch		x		x									
Refrigerant pressure switch, A/C switch, blower fan and A/C amplifier	x	x		x				x					
PSP switch	x	x		x									
DLC in engine compartment (TEN)	x	x	x	x				x					
Neutral switch	x	x	x	x									
Clutch switch	x	x	x	x									
TR switch	x	x	x	x									
CKP sensor	x	x	x	x	x	x	x	x	x	x	x	x	x
CMP sensor		x		x									
VSS	x	x		x						x			x
MAF sensor	x	x		x		x			x	x			
ECT sensor	x	x	x	x		x		x	x	x	x	x	x
IAT sensor	x	x	x	x		x			x	x			x
TP sensor	x	x	x	x		x		x	x	x	x	x	x
EGR boost sensor	x	x							x			x	
Battery positive voltage		x		x		x			x				x
Generator	x			x									x
Front HO2S		x							x				
Rear HO2S		x											
<b>Output</b>													
IAC valve	x												
A/C relay												x	
Cooling fan relay								x					
Condenser fan relay								x					
Fuel pump relay					x								
PRC solenoid vale			x										
Purge solenoid valve									x				
VTCS solenoid valve											x		
EGR valve										x			
HO2S heaters						x							
Ignition coil				x									
Fuel injectors		x											
Generator (Field coil)													x
Generator warning light													x

A3U0103W001

# SYMPTOM TROUBLESHOOTING [ENGINE CONTROL SYSTEM (ZM)]

## Monitoring System

x :Applied

Component	Catalyst monitor	Misfire monitor	Evaporative system monitor	Fuel system monitor	Oxygen sensor monitor	Oxygen sensor heater monitor	EGR system monitor
<b>Input</b>							
Brake switch							
Refrigerant pressure switch, A/C switch, blower fan and A/C amplifier		x		x			x
PSP switch		x		x			x
CKP sensor	x	x	x	x	x	x	x
CMP sensor	x	x	x	x	x	x	x
VSS	x	x	x	x	x		x
MAF sensor	x	x	x	x	x	x	x
ECT sensor	x	x	x	x	x	x	x
IAT sensor	x	x	x	x	x		x
TP sensor	x	x	x	x	x		x
EGR boost sensor							x
Fuel level sensor			x				
Fuel gauge sender unit			x				
Rear HO2S	x				x	x	
Front HO2S	x			x	x	x	
<b>Output</b>							
DLC-2 in passenger compartment (Terminal KLN)	x	x	x	x	x	x	x
MIL	x	x	x	x	x	x	x
Purge solenoid valve			x	x	x		
EGR valve							x
EGR boost sensor solenoid valve							x
Canister drain cut valve			x				
Fuel injectors				x			

01-03A

Y3U103WA6

# SYMPTOM TROUBLESHOOTING [ENGINE CONTROL SYSTEM (ZM)]

## FOREWORD [ZM]

A3U010318881W39

- When the customer reports a vehicle malfunction, check the malfunction indicator light (MIL) and diagnostic trouble code (DTC), then diagnose the malfunction according to following flowchart.
  - If the DTC exists, diagnose the applicable DTC inspection. (See 01–02A–15 DTC TABLE [ZM].)
  - If the DTC does not exist and the MIL does not illuminate or flash, diagnose the applicable symptom troubleshooting. (See 01–03A–7 SYMPTOM DIAGNOSTIC INDEX [ZM].)

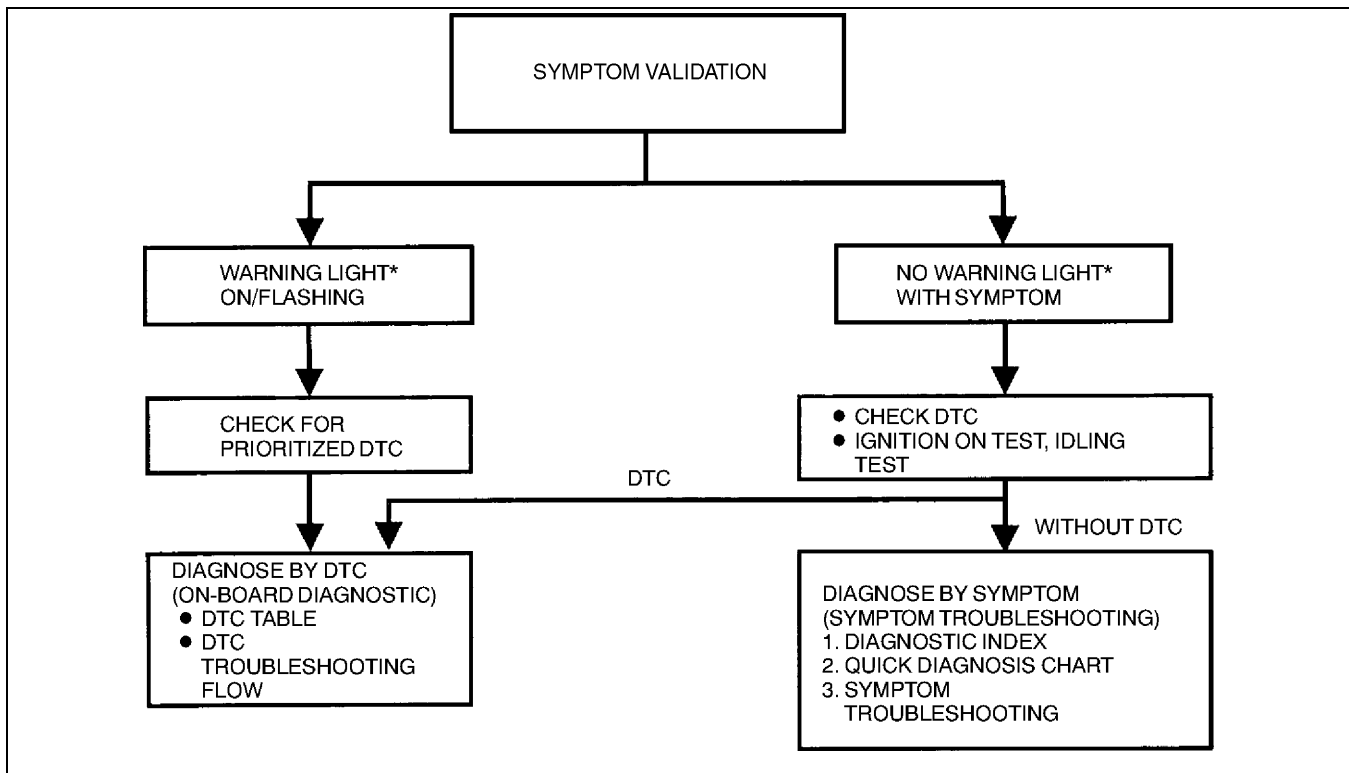

Y3U103WA7

\* : Malfunction Indicator Light (MIL), Generator Warning Light, Security Light

## INTERMITTENT CONCERN TROUBLESHOOTING [ZM]

A3U010318881W40

### Vibration Method

- If malfunction occurs or becomes worse while driving on a rough road or when engine is vibrating, perform the steps below.

#### Note

- There are several reasons vehicle or engine vibration could cause an electrical malfunction. Some of the things to check for are:
  - Connectors not fully seated.
  - Wire harnesses not having full play.
  - Wires laying across brackets or moving parts.
  - Wires routed too close to hot parts.
- An improperly routed, improperly clamped, or loose harness can cause wiring to become pinched between parts.
- The connector joints, points of vibration, and places where wire harnesses pass through the firewall, body panels, etc. are the major areas to be checked.

# SYMPTOM TROUBLESHOOTING [ENGINE CONTROL SYSTEM (ZM)]

## Inspection Method for Switch Connectors or Wires

1. Connect WDS or equivalent to DLC-2.
2. Turn ignition key to ON (Engine OFF).

### Note

- If engine starts and runs, perform the following steps at idle.
3. Access PIDs for the switch you are inspecting.
  4. Turn switch on manually.
  5. Shake each connector or wire harness a bit vertically and horizontally while monitoring the PID.
    - If PID value is unstable, check for poor connection.

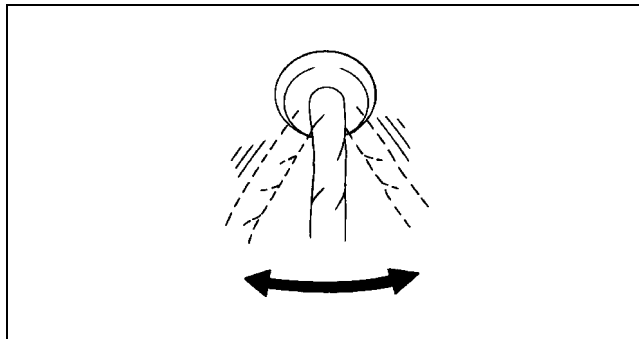

YMU103WC0

## Inspection Method for Sensor Connectors or Wires

1. Connect WDS or equivalent to DLC-2.
2. Turn ignition key to ON (Engine OFF).

### Note

- If engine starts and runs, perform the following steps at idle.
3. Access PIDs for the switch you are inspecting.
  4. Shake each connector or wire harness a bit vertically and horizontally while monitoring the PID.
    - If PID value is unstable, check for poor connection.

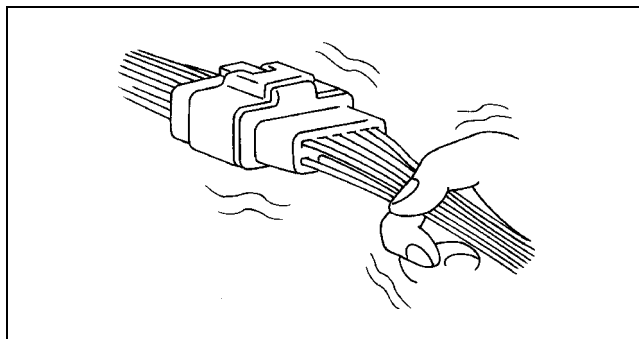

YMU103WC1

## Inspection Method for Sensors

1. Connect WDS or equivalent to DLC-2.
2. Turn ignition key to ON (Engine OFF).

### Note

- If engine starts and runs, perform the following steps at idle.
3. Access PIDs for the switch you are inspecting.
  4. Vibrate the sensor slightly with your finger.
    - If PID value is unstable or malfunction occurs, check for poor connection and/or poorly mounted sensor.

## SYMPTOM TROUBLESHOOTING [ENGINE CONTROL SYSTEM (ZM)]

### Inspection Method for Actuators or Relays

1. Connect WDS or equivalent to DLC-2.
2. Turn ignition key to ON (Engine OFF).

#### Note

- If engine starts and runs, perform the following steps at idle.

3. Prepare the SIMULATION TEST for actuators or relays that you are inspecting.
4. Vibrate the actuator or relay with your finger for **3 seconds** after SIMULATION TEST is activated.
  - If variable click sound is heard, check for poor connection and/or poorly mounted actuator or relay.

#### Note

- Vibrating relays too strongly may result in open relays.

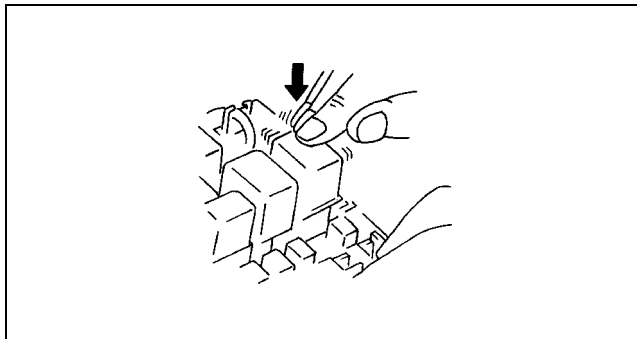

YMU103WC2

### Water Sprinkling Method

If malfunction occurs only during high humidity or rainy/snowy weather, perform the following steps.

#### Caution

- Indirectly change the temperature and humidity by spraying water onto the front of the radiator.
- If a vehicle is subject to water leakage, the leakage may damage the control module. When testing a vehicle with a water leakage problem, special caution must be used.

1. Connect WDS or equivalent to DLC-2 if you are inspecting sensors or switches.
2. Turn ignition key to ON (Engine OFF).

#### Note

- If engine starts and runs, perform the following steps at idle.

3. Access PIDs for sensor or switch if you are inspecting sensors or switches.
  - If you are inspecting the switch, turn it on manually.
4. Spray water onto the vehicle or run it through a car wash.
  - If PID value is unstable or malfunction occurs, repair or replace part as necessary.

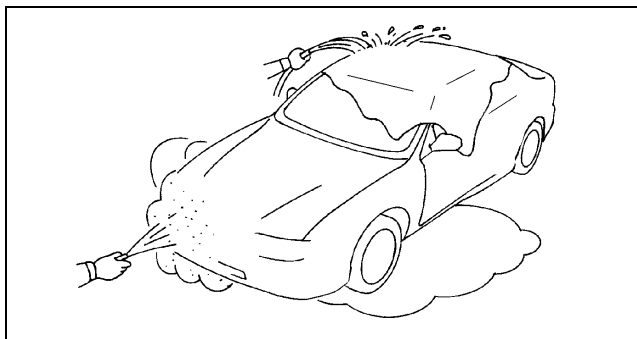

Y5U103WA6

# SYMPTOM TROUBLESHOOTING [ENGINE CONTROL SYSTEM (ZM)]

## SYMPTOM DIAGNOSTIC INDEX [ZM]

A3U010318881W41

- Confirm trouble symptom using the following diagnostic index, then go to appropriate troubleshooting chart.

### Diagnostic Index

No.	TROUBLESHOOTING ITEM		DESCRIPTION	PAGE
1	Melting of main or other fuses		—	(See 01-03A-13 NO.1 MELTING OF MAIN OR OTHER FUSES [ZM].)
2	MIL illuminates		MIL is illuminated incorrectly.	(See 01-03A-14 NO.2 MIL ILLUMINATES [ZM].)
3	Will not crank		Starter does not work.	(See 01-03A-14 NO.3 WILL NOT CRANK [ZM].)
4	Hard start/long crank/erratic start/erratic crank		Starter cranks engine at normal speed but engine requires excessive cranking time before starting.	(See 01-03A-15 NO.4 HARD TO START/LONG CRANK/ERRATIC START/ERRATIC CRANK [ZM].)
5	Engine stalls.	After start/at idle	Engine stops unexpectedly at idle and/or after start.	(See 01-03A-18 NO.5 ENGINE STALLS-AFTER START/AT IDLE [ZM].)
6	Crank normally but will not start		Starter cranks engine at normal speed but engine will not run.	(See 01-03A-21 NO.6 CRANKS NORMALLY BUT WILL NOT START [ZM].)
7	Slow return to idle		Engine takes more time than normal to return to idle speed.	(See 01-03A-24 NO.7 SLOW RETURN TO IDLE [ZM].)
8	Engine runs rough/rolling idle		Engine speed fluctuates between specified idle speed and lower speed and engine shakes excessively.	(See 01-03A-25 NO.8 ENGINE RUNS ROUGH/ROLLING IDLE [ZM].)
9	Fast idle/runs on		Engine speed continues at fast idle after warm-up. Engine runs after ignition key is turned to OFF.	(See 01-03A-27 NO.9 FAST IDLE/RUNS ON [ZM].)
10	Low idle/stalls during deceleration		Engine stops unexpectedly at beginning of deceleration or recovery from deceleration.	(See 01-03A-28 NO.10 LOW IDLE/STALLS DURING DECELERATION [ZM].)
11	Engine stalls/quits.	Acceleration/cruise	Engine stops unexpectedly at beginning of acceleration or during acceleration. Engine stops unexpectedly while cruising.	(See 01-03A-29 NO.11 ENGINE STALLS/QUITS, ENGINE RUNS ROUGH, MISSES, BUCK/JERK, HESITATION/STUMBLE, SURGES [ZM].)
	Engine runs rough	Acceleration/cruise	Engine speed fluctuates during acceleration or cruising.	
	Misses	Acceleration/cruise	Engine misses during acceleration or cruising.	
	Buck/jerk	Acceleration/cruise/deceleration	Vehicle bucks/jerks during acceleration, cruising, or deceleration.	
	Hesitation/stumble	Acceleration	Momentary pause at beginning of acceleration, or during acceleration	
	Surges	Acceleration/cruise	Momentary minor irregularity in engine output	
12	Lack/loss of power	Acceleration/cruise	Performance is poor under load (e.g. power down when climbing hills).	(See 01-03A-32 NO.12 LACK/LOSS OF POWER-ACCELERATION/CRUISE [ZM].)
13	Knocking/pinging	Acceleration/cruise	Sound is produced when air/fuel mixture is ignited by something other than spark plug (e.g. hot spot in combustion chamber).	(See 01-03A-34 NO.13 KNOCKING/PINGING-ACCELERATION/CRUISE [ZM].)
14	Poor fuel economy		Fuel economy is unsatisfactory.	(See 01-03A-35 NO.14 POOR FUEL ECONOMY [ZM].)
15	Emission compliance		Fails emissions test	(See 01-03A-37 NO.15 EMISSION COMPLIANCE [ZM].)
16	High oil consumption/leakage		Oil consumption is excessive.	(See 01-03A-38 NO.16 HIGH OIL CONSUMPTION/LEAKAGE [ZM].)

01-03A

## SYMPTOM TROUBLESHOOTING [ENGINE CONTROL SYSTEM (ZM)]

No.	TROUBLESHOOTING ITEM		DESCRIPTION	PAGE
17	Cooling system concerns	Overheating	Engine runs at higher than normal temperature/overheats.	(See 01-03A-39 NO.17 COOLING SYSTEM CONCERNS-OVERHEATING [ZM].)
18	Cooling system concerns	Runs cold	Engine does not reach normal operating temperature.	(See 01-03A-40 NO.18 COOLING SYSTEM CONCERNS-RUNS COLD [ZM].)
19	Exhaust smoke		Blue, black, or white smoke from exhaust system	(See 01-03A-41 NO.19 EXHAUST SMOKE [ZM].)
20	Fuel odor (in engine compartment)		Gasoline fuel smell or visible leakage	(See 01-03A-43 NO.20 FUEL ODOR (IN ENGINE COMPARTMENT) [ZM].)
21	Engine noise		Engine noise from under hood	(See 01-03A-44 NO.21 ENGINE NOISE [ZM].)
22	Vibration concerns (engine)		Vibration from under hood or driveline	(See 01-03A-45 NO.22 VIBRATION CONCERNS (ENGINE) [ZM].)
23	A/C does not work sufficiently.		A/C compressor magnetic clutch does not engage when A/C is turned on.	(See 01-03A-45 NO.23 A/C DOES NOT WORK SUFFICIENTLY [ZM].)
24	A/C is always ON/A/C compressor runs continuously.		A/C compressor magnetic clutch does not disengage.	(See 01-03A-46 NO.24 A/C IS ALWAYS ON/A/C COMPRESSOR RUNS CONTINUOUSLY [ZM].)
25	A/C does not cut off under wide open throttle conditions.		A/C compressor magnetic clutch does not disengage under wide open throttle.	(See 01-03A-47 NO.25 A/C DOES NOT CUT OFF UNDER WIDE OPEN THROTTLE CONDITIONS [ZM].)
26	Exhaust sulphur smell		Rotten egg smell (sulphur) from exhaust	(See 01-03A-47 NO.26 EXHAUST SULPHUR SMELL [ZM].)
27	Fuel refill concerns		Fuel tank does not fill smoothly.	(See 01-03A-48 NO.27 FUEL REFILL CONCERNS [ZM].)
28	Fuel filling shut off issues		Fuel does not shut off properly.	(See 01-03A-49 NO.28 FUEL FILLING SHUT OFF ISSUES [ZM].)
29	Intermittent concerns		Symptom occurs randomly and is difficult to diagnose.	(See 01-03A-49 NO.29 INTERMITTENT CONCERNS [ZM].)
30	Constant voltage		Incorrect constant voltage	(See 01-03A-50 NO.30 CONSTANT VOLTAGE [ZM].)
31	Spark plug condition		Incorrect spark plug condition	(See 01-03A-52 NO.31 SPARK PLUG CONDITION [ZM].)
32	ATX concerns	Upshift/downshift/engagement	ATX concerns not related to engine performance	(See 05-03-7 AUTOMATIC TRANSAXLE SYMPTOM TROUBLESHOOTING ITEM TABLE.)

# SYMPTOM TROUBLESHOOTING [ENGINE CONTROL SYSTEM (ZM)]

## SYMPTOM QUICK DIAGNOSIS CHART [ZM]

A3U010318881W42

X: Applied

01-03A

Possible factor																							
Troubleshooting item		Starter motor malfunction(Mechanical or electrical)	Starter circuit including ignition switch open	Improper engine oil level	Low or dead battery	Charging system malfunction	Improper engine compression	Improper valve timing	Hydrolocked engine	Improper engine oil viscosity	Improper dipstick	Base engine malfunction	Drive plate or flywheel is seized.	Improper tension or damages drive belts	Improper engine coolant level	Water and anti-freeze mixture is improper.	Cooling system malfunction (Radiator,hoses,overflow system,thermostat,etc.)	Cooling fan system malfunction	Engine or transaxle mounts are improperly installed.	Cooling fan or condenser fan seat is improper.	Accelerator cable free play misadjustment	Fuel quality	
1	Melting of main or other fuses	x	x																				
2	MIL illuminates.																						
3	Will not crank	x	x		x	x			x				x										
4	Hard start/long crank/erratic start/erratic crank																						x
5	Engine stalls.      After start/at idle								x	x	x												x
6	Cranks normally but will not start								x	x	x												x
7	Slow return to idle																		x				
8	Engine runs rough/rolling idle								x	x													x
9	Fast idle/runs on																				x		
10	Low idle/stalls during deceleration																						
11	Engine stalls/quits.      Acceleration/cruise								x	x													x
	Engine runs rough.      Acceleration/cruise								x	x													x
	Misses      Acceleration/cruise								x	x													x
	Buck/jerk      Acceleration/cruise/deceleration								x	x													x
	Hesitation/stumble      Acceleration								x	x													x
	Surges      Acceleration/cruise								x	x													x
12	Lack/loss of power      Acceleration/cruise								x	x													x
13	Knocking/pinging      Acceleration/cruise								x														x
14	Poor fuel economy								x	x					x								x
15	Emissions compliance								x	x													
16	High oil consumption/leakage										x	x	x										
17	Cooling system concerns      Overheating														x	x	x						
18	Cooling system concerns      Runs cold																						
19	Exhaust smoke																						
20	Fuel odor (in engine compartment)																						
21	Engine noise				x																		
22	Vibration concerns (engine)																						
23	A/C does not work sufficiently.																						
24	A/C is always on or A/C compressor runs continuously.																						
25	A/C does not cut off under wide open throttle conditions.																						
26	Exhaust sulphur smell																						x
27	Fuel refill concerns																						
28	Fuel filling shut off issues																						
29	Intermittent concerns									x													
30	Constant voltage																						
31	Spark plug condition									x													x
32	Automatic transaxle concerns      Upshift/downshift/engagement																						

See 05-03 AUTOMATIC TRANSAXLE SYMPTOM TROUBLESHOOTING ITEM TABLE

Y3U103WA0



# SYMPTOM TROUBLESHOOTING [ENGINE CONTROL SYSTEM (ZM)]

×: Applied

Troubleshooting item		Possible factor																
		Engine overheating	Air cleaner element clogging or restriction	Air leakage from intake-air system (Loose, tubes, cracks, gaskets breakage)	IAC valve improper operation	Throttle body malfunction	Tumble swirl control system malfunction	Vacuum leakage (Vacuum hose damage, misrouting)	Ignition coil malfunction (e.g. open, short or cracks)	Initial Ignition timing misadjustment (CKP & crankshaft pulley misadjustment)	Spark plug malfunction	High-tension leads malfunction (Cracks, open, low resistance)	CKP sensor is damage (e.g. open or short circuits).	Crankshaft pulley is damaged.	Improper gap between CKP sensor and crankshaft pulley	Fuel pump malfunction (Mechanical or electrical)	Pressure regulator malfunction	Fuel hoses restriction or clogging
1	Melting of main or other fuses																	
2	MIL illuminates.																	
3	Will not crank																	
4	Hard start/long crank/erratic start/erratic crank		x	x				x			x	x	x	x	x	x	x	x
5	Engine stalls	After start/at idle	x	x	x	x		x	x	x	x	x	x	x	x	x	x	x
6	Cranks normally but will not start		x		x	x		x	x	x	x	x	x	x	x	x	x	x
7	Slow return to idle					x												
8	Engine runs rough/rolling idle		x		x	x		x		x	x	x	x	x	x	x	x	x
9	Fast idle/runs on																	
10	Low idle/stalls during deceleration				x	x												
11	Engine stalls/quits.	Acceleration/cruise	x	x	x		x				x		x	x	x	x	x	x
	Engine runs rough.	Acceleration/cruise	x	x	x		x				x		x	x	x	x	x	x
	Misses	Acceleration/cruise	x	x	x		x				x		x	x	x	x	x	x
	Buck/jerk	Acceleration/cruise/deceleration	x	x	x		x				x		x	x	x	x	x	x
	Hesitation/stumble	Acceleration	x	x	x		x				x		x	x	x	x	x	x
	Surges	Acceleration/cruise	x	x	x		x				x		x	x	x	x	x	x
12	Lack/loss of power	Acceleration/cruise	x	x	x		x	x			x		x	x	x	x	x	x
13	Knocking/pinging	Acceleration/cruise	x													x	x	
14	Poor fuel economy			x				x				x	x				x	x
15	Emissions compliance			x		x						x	x				x	x
16	High oil consumption/leakage																	
17	Cooling system concerns	Overheating																
18	Cooling system concerns	Runs cold																
19	Exhaust smoke			x								x	x				x	x
20	Fuel odor (in engine compartment)																	x
21	Engine noise				x				x									
22	Vibration concerns (engine)																	
23	A/C does not work sufficiently.																	
24	A/C is always on or A/C compressor runs continuously.																	
25	A/C does not cut off under wide open throttle conditions.																	
26	Exhaust sulphur smell																	
27	Fuel refill concerns																	
28	Fuel filling shut off issues																	
29	Intermittent concerns					x			x	x		x	x	x			x	x
30	Constant voltage																	
31	Spark plug condition																	x
32	Automatic transaxle concerns	Upshift/downshift/engagement																

See 05-03 AUTOMATIC TRANSAXLE SYMPTOM TROUBLESHOOTING ITEM TABLE

# SYMPTOM TROUBLESHOOTING [ENGINE CONTROL SYSTEM (ZM)]

X: Applied

Troubleshooting item		Possible factor																	
		Injectors malfunction (Leakage or clogging, Inoperative)	Fuel leakage from fuel system (Including Insulator, Injector O-ring)	Fuel filters restriction or clogging	PRC solenoid valve improper operation	CMP sensor is damaged (e.g. open or short circuit).	Camshaft is damaged.	Improper air/fuel mixture ratio control	Exhaust system restriction or clogging	Catalytic converter malfunction	EGR system malfunction	Evaporative emission control system malfunction	PCV valve malfunction	V-reference supply circuit malfunction	Main relay malfunction (Mechanical or electrical)	ECT sensor malfunction	TR switch misadjustment (ATX)	P/N position switch in TR switch is open, (ATX)	Brake switch and related circuit malfunction
1	Melting of main or other fuses																		
2	MIL illuminates.																		
3	Will not crank																	X	
4	Hard start/long crank/erratic start/erratic crank			X	X			X	X		X	X	X						
5	Engine stalls.      After start/at idle	X	X					X	X		X	X	X		X				
6	Cranks normally but will not start	X	X					X	X		X	X	X	X	X				
7	Slow return to idle															X			
8	Engine runs rough/rolling idle	X		X		X	X	X	X		X	X	X						
9	Fast idle/runs on															X			
10	Low idle/stalls during deceleration							X				X							X
11	Engine stalls/quits.      Acceleration/cruise	X		X		X	X	X	X		X	X	X	X	X				
	Engine runs rough.      Acceleration/cruise	X		X		X	X	X	X		X	X	X	X	X				
	Misses      Acceleration/cruise	X		X		X	X	X	X		X	X	X	X	X				
	Buck/jerk      Acceleration/cruise/deceleration	X		X		X	X	X	X		X	X	X	X	X				
	Hesitation/stumble      Acceleration	X		X		X	X	X	X		X	X	X	X	X				
Surges      Acceleration/cruise	X		X		X	X	X	X		X	X	X	X	X					
12	Lack/loss of power      Acceleration/cruise	X				X	X		X		X	X	X						
13	Knocking/pinging      Acceleration/cruise																		
14	Poor fuel economy			X	X	X	X		X				X						
15	Emissions compliance			X		X	X	X	X	X	X	X	X						
16	High oil consumption/leakage												X						
17	Cooling system concerns      Overheating																		
18	Cooling system concerns      Runs cold																		
19	Exhaust smoke	X			X								X						
20	Fuel odor (in engine compartment)		X									X							
21	Engine noise																		
22	Vibration concerns (engine)																		
23	A/C does not work sufficiently.																		
24	A/C is always on or A/C compressor runs continuously.																		
25	A/C does not cut off under wide open throttle conditions.																		
26	Exhaust sulphur smell												X						
27	Fuel refill concerns												X						
28	Fuel filling shut off issues												X						
29	Intermittent concerns	X			X					X	X	X			X	X	X	X	X
30	Constant voltage																		
31	Spark plug condition	X	X					X								X			
32	Automatic transaxle concerns      Upshift/downshift/engagement																		

See 05-03 AUTOMATIC TRANSAXLE SYMPTOM TROUBLESHOOTING ITEM TABLE

01-03A

Z3U0103W999

# SYMPTOM TROUBLESHOOTING [ENGINE CONTROL SYSTEM (ZM)]

X: Applied

Troubleshooting item		Possible factor																		
		Neutral or clutch switch and related circuit malfunction (MTX)	MAF sensor and related circuit malfunction	TP sensor and related circuit malfunction	TP sensor misadjustment (Including looseness)	Power steering pressure switch and related circuit malfunction	Improper refrigerant charging amount	A/C relay (A/C control signal) circuit malfunction	Condenser fan system malfunction	Improper load signal input	Clutch slippage	Automatic transaxle related parts malfunction	VSS and related circuit malfunction	Improper ATF level	Brake dragging	Loose parts	Wheels and tires improper balance	Driveline malfunction	Suspension malfunction	
1	Melting of main or other fuses																			
2	MIL illuminates																			
3	Will not crank																			
4	Hard start/long crank/erratic start/erratic crank		X																	
5	Engine stalls.      After start/at idle						X	X	X											
6	Cranks normally but will not start																			
7	Slow return to idle									X										
8	Engine runs rough/rolling idle					X	X	X	X	X										
9	Fast idle/runs on									X										
10	Low idle/stalls during deceleration	X	X	X	X			X												
11	Engine stalls/quits.      Acceleration/cruise		X	X	X			X	X	X	X	X	X							
	Engine runs rough.      Acceleration/cruise		X	X	X			X	X	X	X	X	X							
	Misses      Acceleration/cruise		X	X	X			X	X	X	X	X	X							
	Buck/jerk      Acceleration/cruise/deceleration		X	X	X			X	X	X	X	X	X							
	Hesitation/stumble      Acceleration		X	X	X			X	X	X	X	X	X							
	Surges      Acceleration/cruise		X	X	X			X	X	X	X	X	X							
12	Lack/loss of power      Acceleration/cruise							X	X	X	X	X	X		X					
13	Knocking/pinging      Acceleration/cruise		X																	
14	Poor fuel economy								X					X	X					
15	Emissions compliance																			
16	High oil consumption/leakage																			
17	Cooling system concerns      Overheating							X	X	X										
18	Cooling system concerns      Runs cold									X										
19	Exhaust smoke																			
20	Fuel odor (in engine compartment)																			
21	Engine noise																X			
22	Vibration concerns (engine)																	X	X	X
23	A/C does not work sufficiently.							X	X	X										
24	A/C is always on or A/C compressor runs continuously								X	X										
25	A/C does not cut off under wide open throttle conditions.			X	X															
26	Exhaust sulphur smell																			
27	Fuel refill concerns																			
28	Fuel filling shut off issues																			
29	Intermittent concerns	X	X	X		X		X			X									
30	Constant voltage																			
31	Spark plug condition		X																	
32	Automatic transaxle concerns      Upshift/downshift/engagement																			See 05-03 AUTOMATIC TRANSAXLE SYMPTOM TROUBLESHOOTING ITEM TABLE

# SYMPTOM TROUBLESHOOTING [ENGINE CONTROL SYSTEM (ZM)]

## NO.1 MELTING OF MAIN OR OTHER FUSES [ZM]

A3U010318881W43

### 1 Melting of main or other fuses

#### [TROUBLESHOOTING HINTS]

Inspect condition of fuse.

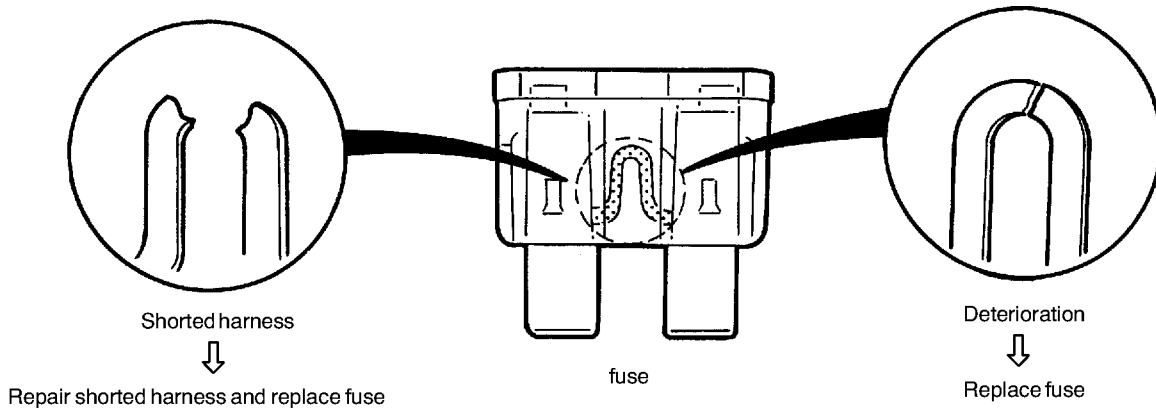

01-03A

Damaged Fuse	Related Wiring Harness
MAIN (100A)	<b>MAIN fuse</b> <ul style="list-style-type: none"> <li>• Generator</li> </ul>
IG KEY (60A)	<b>IG KEY fuse</b> <ul style="list-style-type: none"> <li>• Ignition switch</li> </ul>
A/C (15A)	<b>A/C fuse</b> <ul style="list-style-type: none"> <li>• A/C relay</li> <li>• Condenser fan relay</li> </ul>
A/C (10A)	<b>A/C relay</b> <ul style="list-style-type: none"> <li>• Magnet clutch</li> </ul>
AD FAN (30A)	<b>Condenser fan relay</b> <ul style="list-style-type: none"> <li>• Condenser fan motor</li> </ul>
INJ (30A)	<b>INJ fuse</b> <ul style="list-style-type: none"> <li>• PCM</li> </ul> <b>Main relay</b> <ul style="list-style-type: none"> <li>• PCM</li> <li>• Fuel pump relay</li> <li>• Fuel injectors</li> <li>• Purge solenoid valve</li> <li>• PRC solenoid valve</li> <li>• VTCS solenoid valve</li> </ul> <b>Fuel pump relay</b> <ul style="list-style-type: none"> <li>• Fuel pump</li> </ul> <ul style="list-style-type: none"> <li>• Mass air flow sensor</li> <li>• Vehicle speedometer sensor</li> <li>• EGR valve</li> <li>• EGR boost sensor solenoid valve</li> <li>• CDCV</li> <li>• CMP sensor</li> </ul>
ENGINE (10A)	<b>ENGINE fuse</b> <ul style="list-style-type: none"> <li>• Ignition coil</li> <li>• Condenser</li> <li>• Heated oxygen sensor</li> <li>• Main relay</li> <li>• Cooling fan relay</li> <li>• Malfunction indicator lamp</li> </ul>
METER (10A)	<b>METER fuse</b> <ul style="list-style-type: none"> <li>• Transaxle range switch (ATX)</li> <li>• O/D OFF indicator light (ATX)</li> </ul>
COOLING FAN (30A)	<b>Cooling fan relay</b> <ul style="list-style-type: none"> <li>• Cooling fan motor</li> </ul>

- If malfunction remains, refer to related Service Bulletins and perform repair or diagnosis.
  - If vehicle is repaired, troubleshooting completed.
  - If vehicle is not repaired or additional diagnostic information is not available, replace PCM.

# SYMPTOM TROUBLESHOOTING [ENGINE CONTROL SYSTEM (ZM)]

## NO.2 MIL ILLUMINATES [ZM]

A3U010318881W44

<b>2</b>	<b>Mil illuminates</b>
<b>DESCRIPTION</b>	<ul style="list-style-type: none"> <li>MIL is illuminated incorrectly.</li> </ul>
<b>POSSIBLE CAUSE</b>	<ul style="list-style-type: none"> <li>PCM illuminates for emission-related concern (DTC are stored in PCM)</li> <li>Short to GND circuit between MIL (located on instrument cluster) and PCM</li> </ul> <p><b>Note</b></p> <ul style="list-style-type: none"> <li>If MIL blinks at steady rate, misfire condition could possibly exist.</li> </ul>

### Diagnostic procedure

STEP	INSPECTION	ACTION	
1	<ul style="list-style-type: none"> <li>Connect WDS or equivalent to DLC-2.</li> <li>Turn ignition key to ON.</li> <li>Retrieve any DTC.</li> <li>Is "DTC" displayed?</li> </ul>	Yes	<b>DTC is displayed:</b> <ul style="list-style-type: none"> <li>Go to appropriate DTC test.</li> </ul>
		No	<b>No DTC is displayed:</b> <ul style="list-style-type: none"> <li>Inspect for short to GND circuit between MIL (located on instrument cluster) and PCM terminal 2.</li> </ul>
2	<ul style="list-style-type: none"> <li>Verify test results.                             <ul style="list-style-type: none"> <li>If okay, return to diagnostic index to service any additional symptoms.</li> <li>If malfunction remains, inspect related Service Bulletins and perform repair or diagnosis.                                     <ul style="list-style-type: none"> <li>If vehicle is repaired, troubleshooting is completed.</li> <li>If vehicle is not repaired or additional diagnostic information is not available, replace PCM.</li> </ul> </li> </ul> </li> </ul>		

## NO.3 WILL NOT CRANK [ZM]

A3U010318881W45

<b>3</b>	<b>Will not crank</b>
<b>DESCRIPTION</b>	<ul style="list-style-type: none"> <li>Starter does not work.</li> </ul>
<b>POSSIBLE CAUSE</b>	<ul style="list-style-type: none"> <li>Open starter circuit between ignition switch and starter</li> <li>Transaxle range switch malfunction (ATX)</li> <li>Transaxle range switch misadjustment (ATX)</li> <li>Starter interlock switch malfunction (MTX)</li> <li>Starter malfunction</li> <li>Seized/hydrolocked engine, flywheel or drive plate</li> </ul>

### Diagnostic procedure

STEP	INSPECTION	ACTION	
1	<ul style="list-style-type: none"> <li>Inspect for following:                             <ul style="list-style-type: none"> <li>Battery connection</li> <li>Battery condition</li> <li>Transaxle is in Park or Neutral. (ATX)</li> <li>Clutch is fully depressed. (MTX)</li> <li>Fuses</li> </ul> </li> <li>Are all items okay?</li> </ul>	Yes	Go to next step.
		No	Service as necessary. Repeat Step 1.
2	<ul style="list-style-type: none"> <li>Is clicking sound heard from starter when ignition switch is turned to START?</li> </ul>	Yes	Go to next step.
		No	Go to Step 4.
3	<ul style="list-style-type: none"> <li>Inspect starting system. (See 01-19-2 STARTER INSPECTION.)</li> <li>Is starting system okay?</li> </ul>	Yes	Inspect for seized/hydrolocked engine, flywheel or drive plate.
		No	Repair or replace components as required.
4	<ul style="list-style-type: none"> <li>Do any other electrical accessories work?</li> </ul>	Yes	Go to next step.
		No	Inspect charging system. (See 01-17-1 BATTERY INSPECTION.) (See 01-17-3 GENERATOR INSPECTION.)
5	<p><b>Note</b></p> <ul style="list-style-type: none"> <li>Following test should be performed on ATX only. For MTX, go to next step.</li> <li>Inspect adjustment of transaxle range switch.</li> <li>Is transaxle range switch adjusted properly?</li> </ul>	Yes	Go to next step.
		No	Inspect for open circuit between transaxle range switch and PCM terminal 64 or starter.

## SYMPTOM TROUBLESHOOTING [ENGINE CONTROL SYSTEM (ZM)]

STEP	INSPECTION		ACTION
6	<ul style="list-style-type: none"> <li>• Connect WDS or equivalent to DLC-2.</li> <li>• Turn ignition switch on.</li> <li>• Retrieve any DTC.</li> <li>• Is "DTC" displayed?</li> </ul>	Yes	<p><b>DTC is displayed:</b></p> <ul style="list-style-type: none"> <li>• Go to appropriate DTC test.</li> </ul> <p><b>Communication error message is displayed:</b></p> <ul style="list-style-type: none"> <li>• Inspect for following:                             <ul style="list-style-type: none"> <li>— Open circuit between main relay and PCM terminal 71 or 97</li> <li>— Open main relay GND circuit</li> <li>— Main relay is stuck open</li> <li>— Open or poor GND circuit (PCM terminal 24, 51, 76, 77 or 103)</li> <li>— Poor connection of vehicle body GND</li> </ul> </li> </ul>
		No	<p><b>No DTC is displayed:</b></p> <ul style="list-style-type: none"> <li>• Inspect following:                             <ul style="list-style-type: none"> <li>— START circuit in ignition switch</li> <li>— Open circuit between ignition switch and starter</li> <li>— Starter interlock switch (MTX)</li> </ul> </li> </ul>
7	<ul style="list-style-type: none"> <li>• Verify test results.                             <ul style="list-style-type: none"> <li>— If okay, return to diagnostic index to service any additional symptoms.</li> <li>— If malfunction remains, refer to related Service Bulletins and perform repair or diagnosis.                                     <ul style="list-style-type: none"> <li>• If vehicle is repaired, troubleshooting completed.</li> <li>• If vehicle is not repaired or additional diagnostic information is not available, replace PCM.</li> </ul> </li> </ul> </li> </ul>		

01-03A

### NO.4 HARD TO START/LONG CRANK/ERRATIC START/ERRATIC CRANK [ZM]

A3U010318881W46

4	Hard to start/long crank/erratic start/erratic crank
<b>DESCRIPTION</b>	<ul style="list-style-type: none"> <li>• Starter cranks engine at normal speed but engine requires excessive cranking time before start.</li> <li>• Battery is in normal condition.</li> </ul>
<b>POSSIBLE CAUSE</b>	<ul style="list-style-type: none"> <li>• Spark leakage from high-tension leads</li> <li>• Vacuum leakage</li> <li>• Poor fuel quality</li> <li>• Starting system malfunction</li> <li>• Spark plug malfunction</li> <li>• Air leakage from intake-air system</li> <li>• Erratic signal from CKP sensor</li> <li>• Erratic signal from CMP sensor</li> <li>• Air cleaner restriction</li> <li>• IAC valve malfunction</li> <li>• PCV valve malfunction</li> <li>• Inadequate fuel pressure</li> <li>• Purge solenoid valve malfunction</li> <li>• MAF sensor contamination</li> <li>• Restriction in exhaust system</li> <li>• EGR valve malfunction</li> <li>• Pressure regulator control (PRC) system malfunction</li> </ul> <p><b>Warning</b>                      The following troubleshooting flowchart contains fuel system diagnosis and repair procedures. Read following warnings before performing fuel system services:</p> <ul style="list-style-type: none"> <li>• Fuel vapor is hazardous. It can easily ignite, causing serious injury and damage. Always keep sparks and flames away from fuel.</li> <li>• Fuel line spills and leakage are dangerous. Fuel can ignite and cause serious injuries or death and damage. Fuel can also irritate skin and eyes. To prevent this, always complete "BEFORE REPAIR PROCEDURE" and "AFTER REPAIR PROCEDURE" described in this manual.                      (See 01-14-4 BEFORE REPAIR PROCEDURE)                      (See 01-14-5 AFTER REPAIR PROCEDURE)</li> </ul>

## SYMPTOM TROUBLESHOOTING [ENGINE CONTROL SYSTEM (ZM)]

### Diagnostic procedure

STEP	INSPECTION	ACTION	
1	<ul style="list-style-type: none"> <li>• Inspect for following:                             <ul style="list-style-type: none"> <li>— Vacuum leakage</li> <li>— Fuel quality (e.g. proper octane, contamination, winter/summer blend)</li> <li>— Loose bands on intake-air system</li> <li>— Cracks on intake-air system parts</li> <li>— Air cleaner restriction</li> </ul> </li> <li>• Are all items okay?</li> </ul>	Yes	Go to next step.
		No	Service as necessary.
2	<ul style="list-style-type: none"> <li>• Connect WDS or equivalent to DLC-2.</li> <li>• Turn ignition switch on.</li> <li>• Retrieve any DTC.</li> <li>• Is "DTC" displayed?</li> </ul>	Yes	<b>DTC is displayed:</b> <ul style="list-style-type: none"> <li>• Go to appropriate DTC test.</li> </ul>
		No	<b>No DTC is displayed:</b> <ul style="list-style-type: none"> <li>• Go to next step.</li> </ul>
3	<ul style="list-style-type: none"> <li>• Is engine overheating?</li> </ul>	Yes	Go to symptom troubleshooting "NO.17 COOLING SYSTEM CONCERNS — OVERHEATING [ZM]".
		No	Go to next step.
4	<ul style="list-style-type: none"> <li>• Inspect for cracks on high-tension leads.</li> <li>• Are there any cracks on high-tension leads?</li> </ul>	Yes	Repair suspected high-tension leads.
		No	Go to next step.
5	<ul style="list-style-type: none"> <li>• Inspect condition of spark plugs.</li> <li>• Is spark plug wet, covered with carbon or grayish white?</li> </ul>	Yes	<b>Spark plug is wet or covered with carbon:</b> <ul style="list-style-type: none"> <li>• Inspect for fuel leakage from fuel injector.</li> </ul> <b>Spark plug is grayish white:</b> <ul style="list-style-type: none"> <li>• Inspect for clogged fuel injector.</li> </ul>
		No	Install spark plugs on original cylinders. Go to next step.
6	<ul style="list-style-type: none"> <li>• Visually inspect CKP sensor and teeth of crankshaft pulley.</li> <li>• Is CKP sensor and teeth of crankshaft pulley okay?</li> </ul>	Yes	Go to next step.
		No	Replace malfunctioning parts.
7	<ul style="list-style-type: none"> <li>• Measure gap between CKP sensor and teeth of crankshaft pulley.</li> </ul> <p><b>Specification</b> <b>0.5—1.5 mm {0.020—0.59 in}</b></p> <ul style="list-style-type: none"> <li>• Is gap within specification?</li> </ul>	Yes	Go to next step.
		No	Adjust CKP sensor.
8	<ul style="list-style-type: none"> <li>• Remove PCV valve and inspect PCV valve.</li> <li>• Does PCV valve rattle?</li> </ul>	Yes	Go to next step.
		No	Replace PCV valve.
9	<ul style="list-style-type: none"> <li>• Install fuel pressure gauge between fuel filter and fuel distributor.</li> <li>• Connect jumper wire between F/P terminal at DLC in engine compartment and chassis GND. (See 01-14-5 AFTER REPAIR PROCEDURE.)</li> <li>• Turn ignition switch on.</li> <li>• Is fuel line pressure correct?</li> </ul> <p><b>Fuel line pressure</b> <b>270—310 kPa {2.7—3.2 kgf/cm<sup>2</sup>, 39—45 psi}</b></p>	Yes	Go to next step.
		No	<b>Zero or low:</b> <ul style="list-style-type: none"> <li>• Inspect fuel pump circuit.</li> <li>• Inspect for open fuel pump relief valve.</li> <li>• Inspect for fuel leakage inside pressure regulator.</li> <li>• Inspect for clogged main fuel line.</li> <li>• Inspect PRC solenoid valve and related vacuum hose and harness.</li> </ul> <b>High</b> <ul style="list-style-type: none"> <li>• Inspect pressure regulator for high pressure cause.</li> <li>• Inspect for clogged fuel return line.</li> </ul>
10	<ul style="list-style-type: none"> <li>• Is fuel line pressure held after ignition switch is turned off? (See 01-14-28 PRESSURE REGULATOR INSPECTION.)</li> </ul>	Yes	Go to next step.
		No	Inspect pressure regulator diaphragm condition. <ul style="list-style-type: none"> <li>• If condition is okay, inspect fuel injector.</li> <li>• If condition is not okay, replace pressure regulator.</li> </ul>
11	<ul style="list-style-type: none"> <li>• Disconnect vacuum hose from pressure regulator and plug the hose.</li> <li>• Start engine.</li> <li>• Does fuel line pressure remain <b>within ±20 kPa {0.21 kgf/cm<sup>2</sup>, 3 psi}</b> while driving vehicle?</li> </ul>	Yes	Go to next step.
		No	Inspect for clogged fuel filter.

## SYMPTOM TROUBLESHOOTING [ENGINE CONTROL SYSTEM (ZM)]

STEP	INSPECTION	ACTION	
12	<ul style="list-style-type: none"> <li>• Connect vacuum hose to pressure regulator.</li> <li>• Install vacuum gauge to intake manifold.</li> <li>• Start engine.</li> <li>• Does fuel pressure gauge reading increase as vacuum gauge reading decreases and/or fuel pressure gauge reading decreases as vacuum gauge reading increases?</li> </ul>	Yes	Go to next step.
		No	Connect vacuum pump to pressure regulator. Start engine. Verify that fuel pressure gauge reading changes as vacuum changes. <ul style="list-style-type: none"> <li>• If changes, inspect vacuum line.</li> <li>• If does not change, replace pressure regulator.</li> </ul>
13	<ul style="list-style-type: none"> <li>• Disconnect vacuum hose from purge solenoid valve and plug opening end of vacuum hose.</li> <li>• Attempt to start engine.</li> <li>• Is starting condition improved?</li> </ul>	Yes	Inspect if purge solenoid valve sticks open.
		No	Go to next step.
14	<ul style="list-style-type: none"> <li>• Inspect for contaminated MAF sensor.</li> <li>• Is there any contamination?</li> </ul>	Yes	Replace MAF sensor.
		No	Go to next step.
15	<ul style="list-style-type: none"> <li>• Is there a restriction in exhaust system?</li> </ul>	Yes	Inspect exhaust system.
		No	Go to next step.
16	<ul style="list-style-type: none"> <li>• Inspect engine condition while tapping EGR valve housing.</li> <li>• Does engine condition improve?</li> </ul>	Yes	Replace EGR valve.
		No	Go to next step.
17	<ul style="list-style-type: none"> <li>• Inspect starting system. (See 01-19-2 STARTER INSPECTION.)</li> <li>• Is starting system normal?</li> </ul>	Yes	Inspect for loose connectors or poor terminal contact. <ul style="list-style-type: none"> <li>• If okay, remove EGR valve and visually inspect for mechanically stuck EGR valve.</li> </ul>
		No	Repair or replace components as required.
18	<ul style="list-style-type: none"> <li>• Verify test results.                             <ul style="list-style-type: none"> <li>— If okay, return to diagnostic index to service any additional symptoms.</li> <li>— If malfunction remains, refer to related Service Bulletins and perform repair or diagnosis.                                     <ul style="list-style-type: none"> <li>• If vehicle is repaired, troubleshooting completed.</li> <li>• If vehicle is not repaired or additional diagnostic information is not available, replace PCM.</li> </ul> </li> </ul> </li> </ul>		

01-03A



# SYMPTOM TROUBLESHOOTING [ENGINE CONTROL SYSTEM (ZM)]

## NO.5 ENGINE STALLS-AFTER START/AT IDLE [ZM]

A3U010318881W47

<b>5</b>	<b>Engine stalls—after start/at idle</b>
<b>DESCRIPTION</b>	<ul style="list-style-type: none"> <li>• Engine stops unexpectedly.</li> </ul>
<b>POSSIBLE CAUSE</b>	<ul style="list-style-type: none"> <li>• A/C system improper operation</li> <li>• Air leakage from intake-air system parts</li> <li>• Purge solenoid valve malfunction</li> <li>• Improper operation of IAC valve</li> <li>• EGR valve malfunction</li> <li>• No signal from CKP sensor due to sensor, related wire or wrong installation</li> <li>• Vacuum leakage</li> <li>• Low engine compression</li> <li>• Spark leakage from high-tension leads</li> <li>• Poor fuel quality</li> <li>• PCV valve malfunction</li> <li>• Air cleaner restriction</li> <li>• Restriction in exhaust system</li> <li>• Electrical connector disconnection</li> <li>• Open or short circuit in fuel pump and related harness</li> <li>• No battery power supply to PCM or poor GND</li> <li>• Inadequate fuel pressure</li> <li>• Fuel pump mechanical malfunction</li> <li>• Fuel leakage from fuel injector</li> <li>• Fuel injector clogging</li> <li>• Immobilizer system and/or circuit malfunction</li> <li>• Pressure regulator control (PRC) system malfunction</li> </ul> <p><b>Warning</b>  <b>The following troubleshooting flowchart contains fuel system diagnosis and repair procedures. Read following warnings before performing fuel system services:</b></p> <ul style="list-style-type: none"> <li>• <b>Fuel vapor is hazardous. It can easily ignite, causing serious injury and damage. Always keep sparks and flames away from fuel.</b></li> <li>• <b>Fuel line spills and leakage are dangerous. Fuel can ignite and cause serious injuries or death and damage. Fuel can also irritate skin and eyes. To prevent this, always complete “BEFORE REPAIR PROCEDURE” and “AFTER REPAIR PROCEDURE” described in this manual.</b>  <b>(See 01–14–4 BEFORE REPAIR PROCEDURE)</b>  <b>(See 01–14–5 AFTER REPAIR PROCEDURE)</b></li> </ul>

### Diagnostic procedure

STEP	INSPECTION	ACTION				
1	<ul style="list-style-type: none"> <li>• Inspect for following:                             <ul style="list-style-type: none"> <li>— Vacuum connection</li> <li>— Air cleaner element</li> <li>— No air leakage from intake-air system</li> <li>— No restriction of intake-air system</li> <li>— Proper sealing of intake manifold and components attached to intake manifold: EGR valve, IAC valve</li> <li>— Ignition wiring</li> <li>— Fuel quality: proper octane, contamination, winter/summer blend</li> <li>— Electrical connections</li> <li>— Smooth operation of throttle</li> </ul> </li> <li>• Are all items okay?</li> </ul>	<table border="1" style="width: 100%; border-collapse: collapse;"> <tr> <td style="text-align: center; width: 10%;">Yes</td> <td>Go to next step.</td> </tr> <tr> <td style="text-align: center;">No</td> <td>Service as necessary. Repeat Step 1.</td> </tr> </table>	Yes	Go to next step.	No	Service as necessary. Repeat Step 1.
Yes	Go to next step.					
No	Service as necessary. Repeat Step 1.					
2	<ul style="list-style-type: none"> <li>• Turn ignition switch off.</li> <li>• Disconnect TP sensor connector.</li> <li>• Measure voltage at TP sensor connector VREF terminal with ignition switch on.</li> </ul> <p><b>Voltage</b>  <b>4.5—5.5 V</b></p> <ul style="list-style-type: none"> <li>• Is voltage okay?</li> </ul>	<table border="1" style="width: 100%; border-collapse: collapse;"> <tr> <td style="text-align: center; width: 10%;">Yes</td> <td>Go to next step.</td> </tr> <tr> <td style="text-align: center;">No</td> <td>Go to symptom troubleshooting “NO.30 CONSTANT VOLTAGE”.</td> </tr> </table>	Yes	Go to next step.	No	Go to symptom troubleshooting “NO.30 CONSTANT VOLTAGE”.
Yes	Go to next step.					
No	Go to symptom troubleshooting “NO.30 CONSTANT VOLTAGE”.					

## SYMPTOM TROUBLESHOOTING [ENGINE CONTROL SYSTEM (ZM)]

STEP	INSPECTION	ACTION
3	<ul style="list-style-type: none"> <li>• Connect WDS or equivalent to DLC-2.</li> <li>• Turn ignition switch on.</li> <li>• Retrieve any DTC.</li> <li>• Is "DTC" displayed?</li> </ul>	Yes <b>DTC is displayed:</b> <ul style="list-style-type: none"> <li>• Go to appropriate DTC test.</li> </ul> <b>Communication error message is displayed:</b> <ul style="list-style-type: none"> <li>• Inspect for following:                             <ul style="list-style-type: none"> <li>— Open circuit between main relay and PCM terminal 71 or 97</li> <li>— Open main relay GND circuit</li> <li>— Main relay is stuck open.</li> <li>— Open or poor GND circuit (PCM terminal 24, 51, 76, 77 or 103)</li> <li>— Poor connection of vehicle body GND</li> </ul> </li> </ul>
		No <b>No DTC is displayed:</b> <ul style="list-style-type: none"> <li>• Go to next step.</li> </ul>
4	<ul style="list-style-type: none"> <li>• Attempt to start engine at part throttle.</li> <li>• Does engine run smoothly at part throttle?</li> </ul>	Yes Inspect IAC valve and wiring harness.
		No Go to next step.
5	<ul style="list-style-type: none"> <li>• Connect WDS or equivalent to DLC-2.</li> <li>• Access RPM PID.</li> <li>• Is RPM PID indicating engine speed during cranking of engine?</li> </ul>	Yes Go to next step.
		No Inspect for following: <ul style="list-style-type: none"> <li>• Open or short circuit in CKP sensor</li> <li>• Open or short circuit between CKP sensor and PCM terminal 21 or 22</li> <li>• Open or short circuit in CKP sensor harnesses</li> <li>• If CKP sensor and harness are okay, go to next step.</li> </ul>
6	<ul style="list-style-type: none"> <li>• Visually inspect CKP sensor and teeth of crankshaft pulley.</li> <li>• Are CKP sensor and teeth of crankshaft pulley okay?</li> </ul>	Yes Go to next step.
		No Replace malfunctioning parts.
7	<ul style="list-style-type: none"> <li>• Measure gap between CKP sensor and teeth of crankshaft pulley.</li> </ul> <p><b>Gap</b> <b>0.5—1.5 mm {0.020—0.059 in}</b></p> <ul style="list-style-type: none"> <li>• Is gap within specification?</li> </ul>	Yes Go to next step.
		No Adjust CKP sensor.
8	<ul style="list-style-type: none"> <li>• Inspect for cracks on high-tension leads.</li> <li>• Are there any cracks on high-tension leads?</li> </ul>	Yes Repair suspected high-tension leads.
		No Go to next step.
9	<ul style="list-style-type: none"> <li>• Is strong blue spark visible at each disconnected high-tension lead while cranking engine?</li> </ul>	Yes Go to next step. <ul style="list-style-type: none"> <li>• If symptom occurs with A/C on, go to Step 15.</li> </ul>
		No Inspect for following: <ul style="list-style-type: none"> <li>• Open or short circuit in ignition coil</li> <li>• Open circuit in high-tension leads</li> <li>• Open circuit between ignition coil connector GND terminal and body GND</li> <li>• Open circuit between ignition switch and ignition coil</li> <li>• Open circuit between ignition coil and PCM terminal 26 or 52</li> </ul>
10	<ul style="list-style-type: none"> <li>• Inspect condition of spark plugs.</li> <li>• Is spark plug wet, covered with carbon or grayish white?</li> </ul>	Yes <b>Spark plug is wet or covered with carbon:</b> <ul style="list-style-type: none"> <li>• Inspect for fuel leakage from injector.</li> </ul> <b>Spark plug is grayish white:</b> <ul style="list-style-type: none"> <li>• Inspect for clogged fuel injector.</li> </ul>
		No Install spark plugs on original cylinders. Go to next step.
11	<ul style="list-style-type: none"> <li>• Remove and shake PCV valve.</li> <li>• Does PCV valve rattle?</li> </ul>	Yes Go to next step.
		No Replace PCV valve.
12	<ul style="list-style-type: none"> <li>• Inspect for a restriction in exhaust system.</li> <li>• Is there any restriction?</li> </ul>	Yes Inspect exhaust system.
		No Go to next step.

01-03A

## SYMPTOM TROUBLESHOOTING [ENGINE CONTROL SYSTEM (ZM)]

STEP	INSPECTION	ACTION	
13	<ul style="list-style-type: none"> <li>• Install fuel pressure gauge between fuel filter and fuel distributor.</li> <li>• Connect jumper wire between F/P terminal at DLC in engine compartment and GND.</li> <li>• Turn ignition switch on.</li> <li>• Is fuel line pressure correct with ignition switch on?</li> </ul> <p><b>Fuel line pressure</b> 270—310 kPa {2.7—3.2 kgf/cm<sup>2</sup>, 39—45 psi}</p>	Yes	Go to next step.
		No	<p><b>Zero or low:</b></p> <ul style="list-style-type: none"> <li>• Inspect fuel pump circuit.</li> <li>• Inspect for open fuel pump relief valve.</li> <li>• Inspect for fuel leakage inside pressure regulator.</li> <li>• Inspect for clogged main fuel line.</li> <li>• Inspect PRC solenoid valve and related vacuum hose and harness.</li> </ul> <p><b>High</b></p> <ul style="list-style-type: none"> <li>• Inspect pressure regulator for high pressure cause.</li> <li>• Inspect for clogged fuel return line.</li> </ul>
14	<ul style="list-style-type: none"> <li>• Visually inspect for fuel leakage at fuel injector O-ring and fuel line.</li> <li>• Service as necessary.</li> <li>• Does fuel line pressure hold after ignition switch is turned off? (See 01-14-28 PRESSURE REGULATOR INSPECTION.)</li> </ul>	Yes	Go to next step.
		No	<p>Inspect pressure regulator diaphragm condition.</p> <ul style="list-style-type: none"> <li>• If condition is okay, inspect fuel injector.</li> <li>• If condition is not okay, replace pressure regulator.</li> </ul>
15	<p><b>Note</b></p> <ul style="list-style-type: none"> <li>• The following test is for stall concerns with A/C on. If other symptoms exist, go to next step.</li> <li>• Connect pressure gauges to A/C low and high pressure side lines.</li> <li>• Turn A/C on and measure low side and high side pressure.</li> <li>• Are pressures within specifications? (See 07-10-3 REFRIGERANT PRESSURE CHECK.)</li> </ul>	Yes	Go to next step.
		No	<ul style="list-style-type: none"> <li>• If A/C is always on, go to symptom troubleshooting "NO.24 A/C IS ALWAYS ON/A/C COMPRESSOR RUNS CONTINUOUSLY".</li> </ul> <p>For other symptoms, inspect following:</p> <ul style="list-style-type: none"> <li>• Refrigerant charging amount</li> <li>• Condenser fan operation</li> </ul>
16	<ul style="list-style-type: none"> <li>• Disconnect vacuum hose between purge solenoid valve and intake manifold from purge solenoid side.</li> <li>• Plug opening end of vacuum hose.</li> <li>• Start engine.</li> <li>• Is engine stall now eliminated?</li> </ul>	Yes	Inspect if purge solenoid valve sticks open. Inspect evaporative emission control system.
		No	Go to next step.
17	<ul style="list-style-type: none"> <li>• Is air leakage felt or heard at intake-air system components while racing engine to higher speed?</li> </ul>	Yes	Repair or replace.
		No	Go to next step.
18	<ul style="list-style-type: none"> <li>• Inspect engine condition while tapping EGR valve housing.</li> <li>• Does engine condition improve?</li> </ul>	Yes	Replace EGR valve.
		No	Go to next step.
19	<ul style="list-style-type: none"> <li>• Is engine compression correct?</li> </ul>	Yes	Inspect valve timing.
		No	Inspect for cause.
20	<ul style="list-style-type: none"> <li>• Verify test results.                             <ul style="list-style-type: none"> <li>— If okay, return to diagnostic index to service any additional symptoms.</li> <li>— If malfunction remains, refer to related Service Bulletins and perform repair or diagnosis.                                     <ul style="list-style-type: none"> <li>• If vehicle is repaired, troubleshooting completed.</li> <li>• If vehicle is not repaired or additional diagnostic information is not available, replace PCM.</li> </ul> </li> </ul> </li> </ul>		

# SYMPTOM TROUBLESHOOTING [ENGINE CONTROL SYSTEM (ZM)]

## NO.6 CRANKS NORMALLY BUT WILL NOT START [ZM]

A3U010318881W48

<b>6</b>	<b>Cranks normally but will not start</b>
<b>DESCRIPTION</b>	<ul style="list-style-type: none"> <li>• Starter cranks engine at normal speed but engine will not run.</li> <li>• Refer to "ENGINE STALLS" if this symptom appears after engine stall.</li> <li>• Fuel is in tank.</li> <li>• Battery is in normal condition.</li> </ul>
<b>POSSIBLE CAUSE</b>	<ul style="list-style-type: none"> <li>• No battery power supply to PCM</li> <li>• Air leakage from intake-air system</li> <li>• Open PCM GND or vehicle body GND</li> <li>• Improper operation of IAC valve</li> <li>• EGR valve malfunction</li> <li>• No signal from CKP sensor due to sensor, related wire or incorrect installation</li> <li>• No signal from CMP sensor due to sensor, related wire or incorrect installation</li> <li>• Low engine compression</li> <li>• Vacuum leakage</li> <li>• Spark leakage from high-tension leads</li> <li>• Poor fuel quality</li> <li>• PCV valve malfunction</li> <li>• Air cleaner restriction</li> <li>• Restriction in exhaust system</li> <li>• Disconnected electrical connector</li> <li>• Open or short circuit in fuel pump and related harness</li> <li>• Inadequate fuel pressure</li> <li>• Fuel pump mechanical malfunction</li> <li>• Fuel leakage from injector</li> <li>• Fuel injector clogging</li> <li>• Purge solenoid valve malfunction</li> <li>• Pressure regulator solenoid (PRC) system malfunction</li> </ul> <p><b>Warning</b>  <b>The following troubleshooting flowchart contains fuel system diagnosis and repair procedures. Read following warnings before performing fuel system services:</b></p> <ul style="list-style-type: none"> <li>• <b>Fuel vapor is hazardous. It can easily ignite, causing serious injury and damage. Always keep sparks and flames away from fuel.</b></li> <li>• <b>Fuel line spills and leakage are dangerous. Fuel can ignite and cause serious injuries or death and damage. Fuel can also irritate skin and eyes. To prevent this, always complete "BEFORE REPAIR PROCEDURE" and "AFTER REPAIR PROCEDURE" described in this manual.</b>                      (See 01-14-4 BEFORE REPAIR PROCEDURE)                      (See 01-14-5 AFTER REPAIR PROCEDURE)</li> </ul>

01-03A

### Diagnostic procedure

STEP	INSPECTION		ACTION
1	<ul style="list-style-type: none"> <li>• Inspect for following:                             <ul style="list-style-type: none"> <li>— Vacuum connection</li> <li>— External fuel shut off or accessory (kill switch, alarm etc.)</li> <li>— Fuel quality: proper octane, contamination, winter/summer blend</li> <li>— No air leakage from intake-air system</li> <li>— Proper sealing of intake manifold and components attached to intake manifold: EGR valve, IAC valve</li> <li>— Ignition wiring</li> <li>— Electrical connections</li> <li>— Fuses</li> <li>— Smooth operation of throttle</li> </ul> </li> <li>• Are all items okay?</li> </ul>	Yes	Go to next step.
		No	Service as necessary. Repeat Step 1.

## SYMPTOM TROUBLESHOOTING [ENGINE CONTROL SYSTEM (ZM)]

STEP	INSPECTION	ACTION	
2	<ul style="list-style-type: none"> <li>• Connect WDS or equivalent to DLC-2.</li> <li>• Turn ignition switch on.</li> <li>• Retrieve any DTC.</li> <li>• Is "DTC" displayed?</li> </ul>	Yes	<b>No DTC is displayed:</b> <ul style="list-style-type: none"> <li>• Go to next step.</li> </ul>
		No	<b>DTC is displayed:</b> <ul style="list-style-type: none"> <li>• Go to appropriate DTC test.</li> </ul> <b>Communication error message is displayed:</b> <ul style="list-style-type: none"> <li>• Inspect for following:                             <ul style="list-style-type: none"> <li>— Open circuit between main relay and PCM terminal 71 or 97</li> <li>— Open main relay GND circuit</li> <li>— Main relay is stuck open.</li> <li>— Open or poor GND circuit (PCM terminal 24, 51, 76, 77 or 103)</li> <li>— Poor connection of vehicle body GND</li> </ul> </li> </ul>
3	<ul style="list-style-type: none"> <li>• Turn ignition switch off.</li> <li>• Disconnect TP sensor connector.</li> <li>• Measure voltage at TP sensor connector VREF terminal with ignition switch on.</li> </ul> <p><b>Voltage</b> <b>4.5—5.5 V</b></p> <ul style="list-style-type: none"> <li>• Is voltage okay?</li> </ul>	Yes	Go to next step.
		No	Go to symptom troubleshooting "NO.30 CONSTANT VOLTAGE [ZM]".
4	<ul style="list-style-type: none"> <li>• Does engine start with throttle closed?</li> </ul>	Yes	Go to Step 20.
		No	Go to next step.
5	<ul style="list-style-type: none"> <li>• Will engine start and run smoothly at part throttle?</li> </ul>	Yes	Inspect IAC valve and wiring harness.
		No	Go to next step.
6	<ul style="list-style-type: none"> <li>• Connect WDS or equivalent to DLC-2.</li> <li>• Access RPM PID.</li> <li>• Is RPM PID indicating engine speed when cranking engine?</li> </ul>	Yes	Go to next step.
		No	Inspect following: <ul style="list-style-type: none"> <li>• Open or short circuit in CKP sensor</li> <li>• Open or short circuit between CKP sensor and PCM terminal 21 or 22</li> <li>• Open or short circuit in CKP sensor harnesses                             <ul style="list-style-type: none"> <li>— If CKP sensor and harness are okay, go to next step.</li> </ul> </li> </ul>
7	<ul style="list-style-type: none"> <li>• Visually inspect CKP sensor and teeth of crankshaft pulley.</li> <li>• Are CKP sensor and teeth of crankshaft pulley okay?</li> </ul>	Yes	Go to next step.
		No	Replace malfunctioning parts.
8	<ul style="list-style-type: none"> <li>• Measure gap between CKP sensor and teeth of crankshaft pulley.</li> </ul> <p><b>Gap</b> <b>0.5—1.5 mm {0.020—0.059 in}</b></p> <ul style="list-style-type: none"> <li>• Is gap within specification?</li> </ul>	Yes	Go to next step.
		No	Adjust CKP sensor.
9	<ul style="list-style-type: none"> <li>• Inspect for cracks on high-tension leads.</li> <li>• Are there any cracks on high-tension leads?</li> </ul>	Yes	Repair suspected high-tension leads.
		No	Go to next step.
10	<ul style="list-style-type: none"> <li>• Is strong blue spark visible at each disconnected high-tension lead while cranking engine?</li> </ul>	Yes	Go to next step.
		No	Inspect for following: <ul style="list-style-type: none"> <li>• Open or short circuit in ignition coil</li> <li>• Open circuit in high-tension leads</li> <li>• Open circuit between ignition coil connector GND terminal and GND</li> <li>• Open circuit between ignition switch and ignition coil</li> <li>• Open circuit between ignition coil and PCM terminal 26 or 52</li> </ul>
11	<ul style="list-style-type: none"> <li>• Inspect condition of spark plugs.</li> <li>• Is spark plug wet, covered with carbon or grayish white?</li> </ul>	Yes	<b>Spark plug is wet or covered with carbon:</b> <ul style="list-style-type: none"> <li>• Inspect for fuel leakage from injector.</li> </ul> <b>Spark plug is grayish white:</b> <ul style="list-style-type: none"> <li>• Inspect for clogged fuel injector.</li> </ul>
		No	Install spark plugs on original cylinders. Go to next step.
12	<ul style="list-style-type: none"> <li>• Remove and shake PCV valve.</li> <li>• Does PCV valve rattle?</li> </ul>	Yes	Go to next step.
		No	Replace PCV valve.

## SYMPTOM TROUBLESHOOTING [ENGINE CONTROL SYSTEM (ZM)]

STEP	INSPECTION	ACTION	
13	<ul style="list-style-type: none"> <li>• Is there any restriction in exhaust system?</li> </ul>	Yes	Inspect exhaust system.
		No	Go to next step.
14	<ul style="list-style-type: none"> <li>• Install fuel pressure gauge between fuel filter and fuel distributor.</li> <li>• Connect jumper wire between F/P terminal at DLC in engine compartment and GND.</li> <li>• Turn ignition switch on.</li> <li>• Is fuel line pressure correct when ignition switch is cycled on/off five times?</li> </ul> <p><b>Fuel line pressure</b> 270—310 kPa {2.7—3.2 kgf/cm<sup>2</sup>, 39—45 psi}</p>	Yes	Go to next step.
		No	<p><b>Zero or low:</b></p> <ul style="list-style-type: none"> <li>• Inspect fuel pump circuit.</li> <li>• Inspect for open fuel pump relief valve.</li> <li>• Inspect for fuel leakage inside pressure regulator.</li> <li>• Inspect for clogged main fuel line.</li> <li>• Inspect PRC solenoid valve and related vacuum hose and harness.</li> </ul> <p><b>High:</b></p> <ul style="list-style-type: none"> <li>• Inspect pressure regulator for high pressure cause.</li> <li>• Inspect for clogged fuel return line.</li> </ul>
15	<ul style="list-style-type: none"> <li>• Visually inspect for fuel leakage at fuel injector O-ring and fuel line.</li> <li>• Service as necessary.</li> <li>• Is fuel line pressure held after ignition switch is turned off? (See 01-14-28 Operation Inspection.)</li> </ul>	Yes	Go to next step.
		No	Inspect pressure regulator diaphragm condition. <ul style="list-style-type: none"> <li>• If condition is okay, inspect fuel injector.</li> <li>• If condition is not okay, replace pressure regulator.</li> </ul>
16	<ul style="list-style-type: none"> <li>• Disconnect vacuum hose between purge solenoid valve and intake manifold from purge solenoid valve side.</li> <li>• Plug opening end of vacuum hose.</li> <li>• Attempt to start engine.</li> <li>• Is starting condition improved?</li> </ul>	Yes	Inspect if purge solenoid valve sticks open mechanically. Inspect evaporative emission control system.
		No	Go to next step.
17	<ul style="list-style-type: none"> <li>• Is air leakage felt or heard at intake-air system components while racing engine to higher speed?</li> </ul>	Yes	Repair or replace.
		No	Go to next step.
18	<ul style="list-style-type: none"> <li>• Inspect engine condition while tapping EGR valve housing.</li> <li>• Does engine condition improve?</li> </ul>	Yes	Replace EGR valve.
		No	Go to next step.
19	<ul style="list-style-type: none"> <li>• Is engine compression correct?</li> </ul>	Yes	Inspect valve timing.
		No	Inspect for causes.
20	<ul style="list-style-type: none"> <li>• Verify test results.               <ul style="list-style-type: none"> <li>— If okay, return to diagnostic index to service any additional symptoms.</li> <li>— If malfunction remains, refer to related Service Bulletins and perform repair or diagnosis.                   <ul style="list-style-type: none"> <li>• If vehicle is repaired, troubleshooting completed.</li> <li>• If vehicle is not repaired or additional diagnostic information is not available, replace PCM.</li> </ul> </li> </ul> </li> </ul>		

01-03A

# SYMPTOM TROUBLESHOOTING [ENGINE CONTROL SYSTEM (ZM)]

## NO.7 SLOW RETURN TO IDLE [ZM]

A3U010318881W49

<b>7</b>	<b>Slow return to idle</b>
<b>DESCRIPTION</b>	<ul style="list-style-type: none"> <li>• Engine takes more time than normal to return to idle speed.</li> </ul>
<b>POSSIBLE CAUSE</b>	<ul style="list-style-type: none"> <li>• ECT sensor malfunction</li> <li>• Thermostat is stuck open.</li> <li>• Throttle body malfunction</li> <li>• Air leakage from intake-air system</li> </ul>

### Diagnostic procedure

STEP	INSPECTION	ACTION	
1	<ul style="list-style-type: none"> <li>• Connect WDS or equivalent to DLC-2.</li> <li>• Turn ignition switch on.</li> <li>• Retrieve any DTC.</li> <li>• Is "DTC" displayed?</li> </ul>	Yes	<b>DTC is displayed:</b> <ul style="list-style-type: none"> <li>• Go to appropriate DTC test.</li> </ul>
		No	<b>No DTC is displayed:</b> <ul style="list-style-type: none"> <li>• Go to next step.</li> </ul>
2	<ul style="list-style-type: none"> <li>• Remove thermostat and inspect operation. (See 01-12-5 THERMOSTAT REMOVAL/INSTALLATION.)</li> <li>• (See 01-12-7 THERMOSTAT INSPECTION.)</li> <li>• Is thermostat okay?</li> </ul>	Yes	Engine coolant temperature and thermostat are okay. Go to next step.
		No	Access ECT PID on WDS or equivalent. Inspect for both ECT and temperature gauge on instrument cluster readings. <ul style="list-style-type: none"> <li>• If temperature gauge on instrument cluster indicates normal range but ECT is not same as temperature gauge reading, inspect ECT sensor.</li> <li>• If temperature gauge on instrument cluster indicates cold range but ECT is normal, inspect temperature gauge and heat gauge unit.</li> </ul>
3	<ul style="list-style-type: none"> <li>• Is throttle body free of contaminations?</li> </ul>	Yes	Inspect for air leakage from intake-air system components while racing engine to higher speed.
		No	Clean or replace throttle body.
4	<ul style="list-style-type: none"> <li>• Verify test results.               <ul style="list-style-type: none"> <li>— If okay, return to diagnostic index to service any additional symptoms.</li> <li>— If malfunction remains, refer to related Service Bulletins and perform repair or diagnosis.                   <ul style="list-style-type: none"> <li>• If vehicle is repaired, troubleshooting completed.</li> <li>• If vehicle is not repaired or additional diagnostic information is not available, replace PCM.</li> </ul> </li> </ul> </li> </ul>		

# SYMPTOM TROUBLESHOOTING [ENGINE CONTROL SYSTEM (ZM)]

## NO.8 ENGINE RUNS ROUGH/ROLLING IDLE [ZM]

A3U010318881W50

01-03A

<b>8</b>	<b>Engine runs rough/rolling idle</b>
<b>DESCRIPTION</b>	<ul style="list-style-type: none"> <li>Engine speed fluctuates between specified idle speed and lower speed and engine shakes excessively.</li> <li>Idle speed is too slow and engine shakes excessively.</li> </ul>
<b>POSSIBLE CAUSE</b>	<ul style="list-style-type: none"> <li>Air leakage from intake-air system parts</li> <li>A/C system improper operation</li> <li>Spark leakage from high-tension leads</li> <li>Purge solenoid valve malfunction</li> <li>IAC valve improper operation</li> <li>EGR valve malfunction</li> <li>Erratic or no signal from CMP sensor</li> <li>Low engine compression</li> <li>Erratic signal from CKP sensor</li> <li>Poor fuel quality</li> <li>PCV valve malfunction</li> <li>Air cleaner restriction</li> <li>Restriction in exhaust system</li> <li>Disconnected electrical connectors</li> <li>Inadequate fuel pressure</li> <li>Fuel pump mechanical malfunction</li> <li>Fuel leakage from fuel injector</li> <li>Fuel injector clogging</li> <li>Engine overheating</li> <li>Vacuum leakage</li> <li>Pressure regulator control (PRC) system malfunction</li> </ul> <p><b>Warning</b>                      The following troubleshooting flowchart contains fuel system diagnosis and repair procedures. Read following warnings before performing fuel system services:</p> <ul style="list-style-type: none"> <li>Fuel vapor is hazardous. It can easily ignite, causing serious injury and damage. Always keep sparks and flames away from fuel.</li> <li>Fuel line spills and leakage are dangerous. Fuel can ignite and cause serious injuries or death and damage. Fuel can also irritate skin and eyes. To prevent this, always complete "BEFORE REPAIR PROCEDURE" and "AFTER REPAIR PROCEDURE" described in this manual.                      (See 01-14-4 BEFORE REPAIR PROCEDURE.)                      (See 01-14-5 AFTER REPAIR PROCEDURE.)</li> </ul>

### Diagnostic procedure

STEP	INSPECTION	ACTION				
1	<ul style="list-style-type: none"> <li>Inspect for following:                             <ul style="list-style-type: none"> <li>— External fuel shut off or accessory (kill switch, alarm etc.)</li> <li>— Fuel quality: proper octane, contamination, winter/summer blend</li> <li>— No air leakage from intake-air system</li> <li>— Proper sealing of intake manifold and components attached to intake manifold: EGR valve, IAC valve</li> <li>— Ignition wiring</li> <li>— Electrical connections</li> <li>— Fuses</li> <li>— Smooth operation of throttle</li> </ul> </li> <li>Are all items okay?</li> </ul>	<table border="1" style="width: 100%; border-collapse: collapse;"> <tr> <td style="width: 30px; text-align: center;">Yes</td> <td>Go to next step.</td> </tr> <tr> <td style="text-align: center;">No</td> <td>Service as necessary. Repeat Step 1.</td> </tr> </table>	Yes	Go to next step.	No	Service as necessary. Repeat Step 1.
Yes	Go to next step.					
No	Service as necessary. Repeat Step 1.					
2	<ul style="list-style-type: none"> <li>Connect WDS or equivalent to DLC-2.</li> <li>Turn ignition switch on.</li> <li>Retrieve any DTC.</li> <li>Is "DTC" displayed?</li> </ul>	<table border="1" style="width: 100%; border-collapse: collapse;"> <tr> <td style="width: 30px; text-align: center;">Yes</td> <td><b>No DTC is displayed:</b> <ul style="list-style-type: none"> <li>Go to next step.</li> </ul> </td> </tr> <tr> <td style="text-align: center;">No</td> <td><b>DTC is displayed:</b> <ul style="list-style-type: none"> <li>Go to appropriate DTC test.</li> </ul> </td> </tr> </table>	Yes	<b>No DTC is displayed:</b> <ul style="list-style-type: none"> <li>Go to next step.</li> </ul>	No	<b>DTC is displayed:</b> <ul style="list-style-type: none"> <li>Go to appropriate DTC test.</li> </ul>
Yes	<b>No DTC is displayed:</b> <ul style="list-style-type: none"> <li>Go to next step.</li> </ul>					
No	<b>DTC is displayed:</b> <ul style="list-style-type: none"> <li>Go to appropriate DTC test.</li> </ul>					
3	<ul style="list-style-type: none"> <li>Is engine overheating?</li> </ul>	<table border="1" style="width: 100%; border-collapse: collapse;"> <tr> <td style="width: 30px; text-align: center;">Yes</td> <td>Go to symptom troubleshooting "NO.17 COOLING SYSTEM CONCERNS - OVERHEATING [ZM]".</td> </tr> <tr> <td style="text-align: center;">No</td> <td>Go to next step.</td> </tr> </table>	Yes	Go to symptom troubleshooting "NO.17 COOLING SYSTEM CONCERNS - OVERHEATING [ZM]".	No	Go to next step.
Yes	Go to symptom troubleshooting "NO.17 COOLING SYSTEM CONCERNS - OVERHEATING [ZM]".					
No	Go to next step.					



## SYMPTOM TROUBLESHOOTING [ENGINE CONTROL SYSTEM (ZM)]

STEP	INSPECTION	ACTION
4	<p><b>Note</b></p> <ul style="list-style-type: none"> <li>Following test is for engine running rough idle with A/C on concerns. If other symptoms exist, go to next step.</li> <li>Connect pressure gauge to A/C low and high pressure side lines.</li> <li>Start engine and run it at idle.</li> <li>Turn A/C switch on.</li> <li>Measure low side and high side pressures.</li> <li>Are reading pressures within specifications? (See 07–10–3 REFRIGERANT PRESSURE CHECK.)</li> </ul>	Yes Go to next step.
		No If A/C is always on, go to symptom troubleshooting "NO.24 A/C IS ALWAYS ON/A/C COMPRESSOR RUNS CONTINUOUSLY [ZM]". For other symptoms, inspect following: <ul style="list-style-type: none"> <li>Refrigerant charging amount</li> <li>Condenser fan operation</li> </ul>
5	<ul style="list-style-type: none"> <li>Start engine and run it at idle.</li> <li>Turn steering wheel right to left.</li> <li>Does engine running rough exist while turning steering wheel right to left?</li> </ul>	Yes Inspect power steering pressure switch operation and wiring harness between power steering pressure switch connector and PCM connector terminal 31.
		No Go to next step.
6	<ul style="list-style-type: none"> <li>Visually inspect CKP sensor and teeth of crankshaft pulley.</li> <li>Are CKP sensor and teeth of crankshaft pulley okay?</li> </ul>	Yes Go to next step.
		No Replace malfunctioning parts.
7	<ul style="list-style-type: none"> <li>Measure gap between CKP sensor and teeth of crankshaft pulley.</li> </ul> <p><b>Gap</b> <b>0.5—1.5 mm {0.020—0.059 in}</b></p> <ul style="list-style-type: none"> <li>Is gap within specification?</li> </ul>	Yes Go to next step.
		No Adjust CKP sensor.
8	<ul style="list-style-type: none"> <li>Inspect for cracks on high-tension leads.</li> <li>Are there any cracks on high-tension leads?</li> </ul>	Yes Repair suspected high-tension leads.
		No Go to next step.
9	<ul style="list-style-type: none"> <li>Inspect spark plug conditions.</li> <li>Is spark plug wet, covered with carbon or grayish white?</li> </ul>	Yes <b>Spark plug is wet or covered with carbon:</b> <ul style="list-style-type: none"> <li>Inspect for fuel leakage from injector.</li> </ul> <b>Spark plug is grayish white:</b> <ul style="list-style-type: none"> <li>Inspect for clogged fuel injector.</li> </ul>
		No Install spark plugs on original cylinders. Go to next step.
10	<ul style="list-style-type: none"> <li>Start engine and disconnect IAC valve connector.</li> <li>Does rpm drop or engine stall?</li> </ul>	Yes Go to next step.
		No Inspect IAC valve and wiring harness.
11	<ul style="list-style-type: none"> <li>Install fuel pressure gauge between fuel filter and fuel distributor.</li> <li>Start engine and run it at idle.</li> <li>Measure fuel line pressure at idle.</li> <li>Is fuel line pressure correct at idle?</li> </ul> <p><b>Fuel line pressure</b> <b>210—250 kPa {2.1—2.6 kgf/cm<sup>2</sup>, 30—36 psi}</b></p>	Yes Go to next step.
		No <b>Zero or low:</b> <ul style="list-style-type: none"> <li>Inspect fuel pump circuit.</li> <li>Inspect for open fuel pump relief valve.</li> <li>Inspect for fuel leakage inside pressure regulator.</li> <li>Inspect for clogged main fuel line.</li> <li>Inspect PRC solenoid valve and related vacuum hose and harness.</li> </ul> <b>High:</b> <ul style="list-style-type: none"> <li>Inspect pressure regulator for high pressure cause.</li> <li>Inspect for clogged fuel return line.</li> </ul>
12	<ul style="list-style-type: none"> <li>Visually inspect for fuel leakage at fuel injector, O-ring, and fuel line.</li> <li>Service as necessary.</li> <li>Does fuel line pressure hold after ignition switch is turned off? (See 01–14–28 Operation Inspection.)</li> </ul>	Yes Go to next step.
		No Inspect pressure regulator diaphragm condition. <ul style="list-style-type: none"> <li>If condition is okay, inspect fuel injector.</li> <li>If condition is not okay, replace pressure regulator.</li> </ul>
13	<ul style="list-style-type: none"> <li>Connect WDS or equivalent to DLC-2.</li> <li>Start engine and run it at idle.</li> <li>Access LONGFT1 PID.</li> <li>Measure LONGFT1 PID at idle.</li> <li>Is PID value <b>between -25% and +25%</b>?</li> </ul>	Yes Go to next step.
		No LONGFT1 PID is out of specification.  <b>Less than specification (too rich):</b> <ul style="list-style-type: none"> <li>Inspect evaporative emission control system.</li> <li>If system is okay, go to Step 15.</li> </ul> <b>Greater than specification (too lean):</b> <ul style="list-style-type: none"> <li>Inspect for air leakage at intake-air system components.</li> <li>If system okay, go to next step.</li> </ul>

## SYMPTOM TROUBLESHOOTING [ENGINE CONTROL SYSTEM (ZM)]

STEP	INSPECTION	ACTION	
14	<ul style="list-style-type: none"> <li>Disconnect vacuum hose between purge solenoid valve and intake manifold from purge solenoid valve side.</li> <li>Plug opening end of vacuum hose.</li> <li>Start engine.</li> <li>Does engine condition improve?</li> </ul>	Yes	Inspect if purge solenoid valve sticks open mechanically. Inspect evaporative emission control system.
		No	Go to next step.
15	<ul style="list-style-type: none"> <li>Remove and shake PCV valve.</li> <li>Does PCV valve rattle?</li> </ul>	Yes	Go to next step.
		No	Replace PCV valve.
16	<ul style="list-style-type: none"> <li>Is there any restriction in exhaust system?</li> </ul>	Yes	Inspect exhaust system.
		No	Go to next step.
17	<ul style="list-style-type: none"> <li>Visually inspect CMP sensor and projections of camshaft pulley.</li> <li>Are CMP sensor and projections of camshaft pulley okay?</li> </ul>	Yes	Go to next step.
		No	Replace malfunctioning parts.
18	<ul style="list-style-type: none"> <li>Inspect engine condition while tapping EGR valve housing.</li> <li>Does engine condition improve?</li> </ul>	Yes	Replace EGR valve.
		No	Go to next step.
19	<ul style="list-style-type: none"> <li>Is engine compression correct?</li> </ul>	Yes	Inspect valve timing.
		No	Inspect for causes.
20	<ul style="list-style-type: none"> <li>Verify test results.                             <ul style="list-style-type: none"> <li>If okay, return to diagnostic index to service any additional symptoms.</li> <li>If malfunction remains, refer to related Service Bulletins and perform repair or diagnosis.                                     <ul style="list-style-type: none"> <li>If vehicle is repaired, troubleshooting completed.</li> <li>If vehicle is not repaired or additional diagnostic information is not available, replace PCM.</li> </ul> </li> </ul> </li> </ul>		

01-03A

### NO.9 FAST IDLE/RUNS ON [ZM]

A3U010318881W51

9	Fast idle/runs on
<b>DESCRIPTION</b>	<ul style="list-style-type: none"> <li>Engine speed continues at fast idle after warm-up.</li> <li>Engine runs after ignition switch is turned off.</li> </ul>
<b>POSSIBLE CAUSE</b>	<ul style="list-style-type: none"> <li>ECT sensor malfunction</li> <li>Air leakage from intake-air system</li> <li>Throttle body malfunction</li> <li>Accelerator cable free play misadjustment</li> <li>Cruise control cable misadjustment</li> </ul>

### Diagnostic procedure

STEP	INSPECTION	ACTION	
1	<ul style="list-style-type: none"> <li>Connect WDS or equivalent to DLC-2.</li> <li>Access ECT PID.</li> <li>Start and warm-up engine to normal operating temperature.</li> <li>Is ECT PID reading <b>between 82—112 °C {180—234 °F}</b>?</li> </ul>	Yes	Go to next step.
		No	<b>ECT PID is higher than 112 °C {233.6 °F}:</b> <ul style="list-style-type: none"> <li>Go to symptom troubleshooting "NO.17 COOLING SYSTEM CONCERNS — OVERHEATING [ZM]".</li> </ul> <b>ECT PID is less than 82 °C {180 °F}:</b> <ul style="list-style-type: none"> <li>Go to symptom troubleshooting "NO.18 COOLING SYSTEM CONCERNS — RUNS COLD [ZM]".</li> </ul>
2	<ul style="list-style-type: none"> <li>Connect WDS or equivalent to DLC-2.</li> <li>Turn ignition switch on.</li> <li>Retrieve any DTC.</li> <li>Is "DTC" displayed?</li> </ul>	Yes	<b>DTC is displayed:</b> <ul style="list-style-type: none"> <li>Go to appropriate DTC test.</li> </ul>
		No	<b>No DTC is displayed:</b> <ul style="list-style-type: none"> <li>Go to next step.</li> </ul>
3	<ul style="list-style-type: none"> <li>Is there air leakage felt or heard at intake-air system components while racing engine to higher speed?</li> </ul>	Yes	Repair or replace parts as necessary.
		No	Inspect accelerator cable free play. (See 01-13A-13 ACCELERATOR CABLE INSPECTION/ADJUSTMENT [ZM].)
4	<ul style="list-style-type: none"> <li>Verify test results.                             <ul style="list-style-type: none"> <li>If okay, return to diagnostic index to service any additional symptoms.</li> <li>If malfunction remains, refer to related Service Bulletins and perform repair or diagnosis.                                     <ul style="list-style-type: none"> <li>If vehicle is repaired, troubleshooting completed.</li> <li>If vehicle is not repaired or additional diagnostic information is not available, replace PCM.</li> </ul> </li> </ul> </li> </ul>		

# SYMPTOM TROUBLESHOOTING [ENGINE CONTROL SYSTEM (ZM)]

## NO.10 LOW IDLE/STALLS DURING DECELERATION [ZM]

A3U010318881W52

<b>10</b>	<b>Low idle/stalls during deceleration</b>
<b>DESCRIPTION</b>	<ul style="list-style-type: none"> <li>• Engine stops unexpectedly at beginning of deceleration or recovery from deceleration.</li> </ul>
<b>POSSIBLE CAUSE</b>	<ul style="list-style-type: none"> <li>• Vacuum leakage</li> <li>• IAC valve malfunction</li> <li>• Air leakage from intake-air system</li> <li>• TP sensor or related circuit malfunction</li> <li>• MAF sensor or related circuit malfunction</li> <li>• Brake switch or related circuit malfunction</li> <li>• Neutral/clutch switch or related circuit malfunction (MTX)</li> </ul>

### Diagnostic procedure

STEP	INSPECTION		ACTION
1	<ul style="list-style-type: none"> <li>• Does engine idle rough?</li> </ul>	Yes	Go to symptom troubleshooting "NO.8 ENGINE RUNS ROUGH/ROLLING IDLE [ZM]".
		No	Go to next step.
2	<ul style="list-style-type: none"> <li>• Inspect for following:                             <ul style="list-style-type: none"> <li>— Proper routing and no damage of vacuum lines</li> <li>— IAC valve is connected properly.</li> <li>— No air leakage from intake-air system</li> </ul> </li> <li>• Are all items okay?</li> </ul>	Yes	Go to next step.
		No	Service as necessary. Repeat Step 2.
3	<ul style="list-style-type: none"> <li>• Connect WDS or equivalent to DLC-2.</li> <li>• Turn ignition switch on.</li> <li>• Retrieve any DTC.</li> <li>• Is "DTC" displayed?</li> </ul>	Yes	<b>DTC is displayed:</b> <ul style="list-style-type: none"> <li>• Go to appropriate DTC test.</li> </ul>
		No	<b>No DTC is displayed:</b> <ul style="list-style-type: none"> <li>• Go to next step.</li> </ul>
4	<ul style="list-style-type: none"> <li>• Does idle speed drop or stall when disconnecting IAC valve?</li> </ul>	Yes	Go to next step.
		No	Inspect following: <ul style="list-style-type: none"> <li>• Circuit from IAC valve to PCM connector terminal 54 or 83 for open and short</li> <li>• IAC valve for sticking                                     <ul style="list-style-type: none"> <li>— If okay, go to next step.</li> </ul> </li> </ul>
5	<ul style="list-style-type: none"> <li>• Disconnect vacuum hose between purge solenoid valve and intake manifold from purge solenoid valve side.</li> <li>• Plug opening end of vacuum hose.</li> <li>• Drive vehicle.</li> <li>• Does engine condition improve?</li> </ul>	Yes	Inspect evaporative emission control system.
		No	Go to next step.
6	<ul style="list-style-type: none"> <li>• Connect WDS or equivalent to DLC-2.</li> <li>• Access TP, MAF, VSS PIDs.</li> <li>• Monitor each PID while driving vehicle.</li> <li>• Are PIDs okay?</li> </ul>	Yes	Go to symptom troubleshooting "NO.29 INTERMITTENT CONCERNS [ZM]".
		No	<b>TP PID:</b> <ul style="list-style-type: none"> <li>• Inspect TP sensor.</li> </ul> <b>MAF PID:</b> <ul style="list-style-type: none"> <li>• Inspect MAF sensor.</li> </ul> <b>VSS PID:</b> <ul style="list-style-type: none"> <li>• Inspect VSS.</li> </ul>
7	<ul style="list-style-type: none"> <li>• Verify test results.                             <ul style="list-style-type: none"> <li>— If okay, return to diagnostic index to service any additional symptoms.</li> <li>— If malfunction remains, refer to related Service Bulletins and perform repair or diagnosis.                                     <ul style="list-style-type: none"> <li>• If vehicle is repaired, troubleshooting completed.</li> <li>• If vehicle is not repaired or additional diagnostic information is not available, replace PCM.</li> </ul> </li> </ul> </li> </ul>		

# SYMPTOM TROUBLESHOOTING [ENGINE CONTROL SYSTEM (ZM)]

## NO.11 ENGINE STALLS/QUITS, ENGINE RUNS ROUGH, MISSES, BUCK/JERK, HESITATION/STUMBLE, SURGES [ZM]

A3U010318881W53

01-03A

<b>11</b>	<p><b>Engine stalls/quits — acceleration/cruise</b>  <b>Engine runs rough — acceleration/cruise</b>  <b>Misses — acceleration/cruise</b>  <b>Buck/jerk — acceleration/cruise/deceleration</b>  <b>Hesitation/stumble — acceleration</b>  <b>Surges — acceleration/cruise</b></p>
<b>DESCRIPTION</b>	<ul style="list-style-type: none"> <li>• Engine stops unexpectedly at beginning of acceleration or during acceleration.</li> <li>• Engine stops unexpectedly while cruising.</li> <li>• Engine speed fluctuates during acceleration or cruising.</li> <li>• Engine misses during acceleration or cruising.</li> <li>• Vehicle bucks/jerks during acceleration, cruising or deceleration.</li> <li>• Momentary pause at beginning of acceleration or during acceleration</li> <li>• Momentary minor irregularity in engine output</li> </ul>
<b>POSSIBLE CAUSE</b>	<ul style="list-style-type: none"> <li>• A/C system improper operation</li> <li>• Erratic signal or no signal from CMP sensor</li> <li>• Air leakage from intake-air system parts</li> <li>• Purge solenoid valve malfunction</li> <li>• IAC valve improper operation</li> <li>• EGR valve malfunction</li> <li>• Erratic signal from CKP sensor</li> <li>• Low engine compression</li> <li>• Vacuum leakage</li> <li>• Poor fuel quality</li> <li>• Spark leakage from high-tension leads</li> <li>• Air cleaner restriction</li> <li>• PCV valve malfunction</li> <li>• Improper valve timing due to jumping out of timing belt</li> <li>• Restriction in exhaust system</li> <li>• Intermittent open or short in fuel pump circuit</li> <li>• Inadequate fuel pressure</li> <li>• Fuel pump mechanical malfunction</li> <li>• Fuel leakage from fuel injector</li> <li>• Fuel injector clogging</li> <li>• Intermittent open or short of MAF sensor, TP sensor and VSS</li> <li>• ATX malfunction</li> <li>• Clutch slippage</li> </ul> <p><b>Warning</b>  <b>The following troubleshooting flowchart contains fuel system diagnosis and repair procedures. Read following warnings before performing fuel system services:</b></p> <ul style="list-style-type: none"> <li>• <b>Fuel vapor is hazardous. It can easily ignite, causing serious injury and damage. Always keep sparks and flames away from fuel.</b></li> <li>• <b>Fuel line spills and leakage are dangerous. Fuel can ignite and cause serious injuries or death and damage. Fuel can also irritate skin and eyes. To prevent this, always complete “BEFORE REPAIR PROCEDURE” and “AFTER REPAIR PROCEDURE” described in this manual.</b></li> </ul> <p><b>(See 01-14-4 BEFORE REPAIR PROCEDURE.)</b>  <b>(See 01-14-5 AFTER REPAIR PROCEDURE.)</b></p>

### Diagnostic procedure

STEP	INSPECTION	ACTION				
1	<ul style="list-style-type: none"> <li>• Inspect for following:                             <ul style="list-style-type: none"> <li>— Vacuum connection</li> <li>— Air cleaner element</li> <li>— No air leakage from intake-air system</li> <li>— No restriction of intake-air system</li> <li>— Proper sealing of intake manifold and components attached to intake manifold: EGR valve, IAC valve</li> <li>— Ignition wiring</li> <li>— Fuel quality: proper octane, contamination, winter/summer blend</li> <li>— Electrical connections</li> <li>— Smooth operation of throttle</li> </ul> </li> <li>• Are all items okay?</li> </ul>	<table style="width: 100%; border-collapse: collapse;"> <tr> <td style="width: 10%; text-align: center; vertical-align: top;">Yes</td> <td style="padding-left: 10px;">Go to next step.</td> </tr> <tr> <td style="text-align: center; vertical-align: top;">No</td> <td style="padding-left: 10px;">Service as necessary. Repeat Step 1.</td> </tr> </table>	Yes	Go to next step.	No	Service as necessary. Repeat Step 1.
Yes	Go to next step.					
No	Service as necessary. Repeat Step 1.					

## SYMPTOM TROUBLESHOOTING [ENGINE CONTROL SYSTEM (ZM)]

STEP	INSPECTION	ACTION	
2	<ul style="list-style-type: none"> <li>• Connect WDS or equivalent to DLC-2.</li> <li>• Turn ignition switch on.</li> <li>• Retrieve any DTC.</li> <li>• Is "DTC" displayed?</li> </ul>	Yes	<b>DTC is displayed:</b> <ul style="list-style-type: none"> <li>• Go to appropriate DTC test.</li> </ul>
		No	<b>No DTC is displayed:</b> <ul style="list-style-type: none"> <li>• Go to next step.</li> </ul>
3	<ul style="list-style-type: none"> <li>• Is engine overheating?</li> </ul>	Yes	Go to symptom troubleshooting "NO.17 COOLING SYSTEM CONCERNS — OVERHEATING [ZM]".
		No	Go to next step.
4	<ul style="list-style-type: none"> <li>• Connect WDS or equivalent to DLC-2.</li> <li>• Access RPM PID, MAF PID, TP PID, and VSS PID.</li> <li>• Drive vehicle with monitoring PIDs.</li> <li>• Are PIDs within specification?</li> </ul>	Yes	Go to next step.
		No	<b>RPM PID:</b> <ul style="list-style-type: none"> <li>• Inspect CKP sensor and related harness: vibration, intermittent open/short circuit.</li> </ul> <b>MAF PID:</b> <ul style="list-style-type: none"> <li>• Inspect for open circuit of MAF sensor and related wire harness intermittently.</li> </ul> <b>TP PID:</b> <ul style="list-style-type: none"> <li>• Inspect if output signal from TP sensor changes smoothly.</li> </ul> <b>VSS PID:</b> <ul style="list-style-type: none"> <li>• Inspect for open circuit of VSS and related wire harness intermittently.</li> </ul>
5	<ul style="list-style-type: none"> <li>• Visually inspect CKP sensor and teeth of crankshaft pulley.</li> <li>• Are CKP sensor and teeth of crankshaft pulley okay?</li> </ul>	Yes	Go to next step.
		No	Replace malfunctioning parts.
6	<ul style="list-style-type: none"> <li>• Measure gap between CKP sensor and teeth of crankshaft pulley.</li> </ul> <b>Gap</b> <b>0.5—1.5 mm {0.020—0.059 in}</b> <ul style="list-style-type: none"> <li>• Is gap within specification?</li> </ul>	Yes	Go to next step.
		No	Adjust CKP sensor.
7	<ul style="list-style-type: none"> <li>• Inspect condition of spark plugs.</li> <li>• Is spark plug wet, covered with carbon or grayish white?</li> </ul>	Yes	<b>Spark plug is wet or covered with carbon:</b> <ul style="list-style-type: none"> <li>• Inspect for fuel leakage from fuel injector.</li> </ul> <b>Spark plug is grayish white:</b> <ul style="list-style-type: none"> <li>• Inspect for clogged fuel injector.</li> </ul>
		No	Install spark plugs on original cylinders. Go to next step.
8	<ul style="list-style-type: none"> <li>• Remove and shake PCV valve.</li> <li>• Does PCV valve rattle?</li> </ul>	Yes	Go to next step.
		No	Replace PCV valve.
9	<ul style="list-style-type: none"> <li>• Verify that throttle lever is resting on throttle valve stop screw and/or throttle valve orifice plug.</li> <li>• Is lever in correct position?</li> </ul>	Yes	Go to next step.
		No	Adjust as necessary.
10	<ul style="list-style-type: none"> <li>• Are there any restrictions in the exhaust system?</li> </ul>	Yes	Inspect exhaust system.
		No	Go to next step.
11	<ul style="list-style-type: none"> <li>• Install fuel pressure gauge between fuel filter and fuel distributor.</li> <li>• Connect jumper wire between F/P terminal at DLC in engine compartment and chassis GND.</li> <li>• Turn ignition switch on.</li> <li>• Is fuel line pressure correct with ignition switch on?</li> </ul> <b>Fuel line pressure</b> <b>270—310 kPa {2.7—3.2 kgf/cm<sup>2</sup>, 39—45 psi}</b>	Yes	Go to next step.
		No	<b>Zero or low:</b> <ul style="list-style-type: none"> <li>• Inspect fuel pump circuit.</li> <li>• Inspect for open fuel pump relief valve.</li> <li>• Inspect for fuel leakage inside pressure regulator.</li> <li>• Inspect for clogged main fuel line.</li> </ul> <b>High:</b> <ul style="list-style-type: none"> <li>• Inspect pressure regulator for high pressure cause.</li> <li>• Inspect for clogged fuel return line.</li> </ul>
12	<ul style="list-style-type: none"> <li>• Visually inspect for fuel leakage at fuel injector, O-ring, and fuel line.</li> <li>• Service as necessary.</li> <li>• Does fuel line pressure hold after ignition switch is turned off? (See 01-14-28 Operation Inspection.)</li> </ul>	Yes	Go to next step.
		No	Inspect pressure regulator diaphragm condition. <ul style="list-style-type: none"> <li>• If condition is okay, inspect fuel injector.</li> <li>• If condition is not okay, replace pressure regulator.</li> </ul>

## SYMPTOM TROUBLESHOOTING [ENGINE CONTROL SYSTEM (ZM)]

STEP	INSPECTION	ACTION	
13	<p><b>Note</b></p> <ul style="list-style-type: none"> <li>• The following test is for engine stalling with A/C on. If other symptoms exist, go to next step.</li> <li>• Connect pressure gauge to A/C low and high pressure side lines.</li> <li>• Turn A/C on and measure low side and high side pressure.</li> <li>• Are pressures within specifications? (See 07-10-3 REFRIGERANT PRESSURE CHECK.)</li> </ul>	Yes	Go to next step.
		No	If A/C is always on, go to symptom troubleshooting "NO.24 A/C IS ALWAYS ON/A/C COMPRESSOR RUNS CONTINUOUSLY [ZM]". For other symptoms, inspect following: <ul style="list-style-type: none"> <li>• Refrigerant charging amount</li> <li>• Condenser fan operation</li> </ul>
14	<p><b>Note</b></p> <ul style="list-style-type: none"> <li>• The following test is performed for symptom with cruise control on. If other symptoms exist, go to next step.</li> <li>• Inspect cruise control system.</li> <li>• Is cruise control system okay?</li> </ul>	Yes	Go to next step.
		No	Repair or replace malfunctioning parts.
15	<ul style="list-style-type: none"> <li>• Disconnect vacuum hose between purge solenoid valve and intake manifold from purge solenoid valve side.</li> <li>• Plug opening end of vacuum hose.</li> <li>• Drive vehicle.</li> <li>• Does engine condition improve?</li> </ul>	Yes	Inspect if purge solenoid valve sticks open mechanically. Inspect evaporative emission control system.
		No	Go to next step.
16	<ul style="list-style-type: none"> <li>• Visually inspect CMP sensor and projections of camshaft pulley.</li> <li>• Are CMP sensor and projections of camshaft pulley okay?</li> </ul>	Yes	Go to next step.
		No	Replace malfunctioning parts.
17	<ul style="list-style-type: none"> <li>• Inspect EGR valve. (See 01-16-15 EGR VALVE INSPECTION.) — Is EGR valve okay?</li> </ul>	Yes	Go to next step.
		No	Replace malfunctioning parts.
18	<ul style="list-style-type: none"> <li>• Is engine compression correct?</li> </ul>	Yes	Inspect following: <ul style="list-style-type: none"> <li>• Valve timing</li> <li>• Internal transaxle part (ATX)</li> <li>• Clutch (MTX)</li> </ul>
		No	Inspect for cause.
19	<ul style="list-style-type: none"> <li>• Verify test results.                             <ul style="list-style-type: none"> <li>— If okay, return to diagnostic index to service any additional symptoms.</li> <li>— If malfunction remains, refer to related Service Bulletins and perform repair or diagnosis.                                     <ul style="list-style-type: none"> <li>• If vehicle is repaired, troubleshooting completed.</li> <li>• If vehicle is not repaired or additional diagnostic information is not available, replace PCM.</li> </ul> </li> </ul> </li> </ul>		

01-03A

# SYMPTOM TROUBLESHOOTING [ENGINE CONTROL SYSTEM (ZM)]

## NO.12 LACK/LOSS OF POWER-ACCELERATION/CRUISE [ZM]

A3U010318881W54

<b>12</b>	<b>Lack/loss of power — acceleration/cruise</b>
<b>DESCRIPTION</b>	<ul style="list-style-type: none"> <li>• Performance is poor under load (e.g., power down when climbing hills).</li> </ul>
<b>POSSIBLE CAUSE</b>	<ul style="list-style-type: none"> <li>• Improper A/C system operation</li> <li>• Erratic signal or no signal from CMP sensor</li> <li>• Air leakage from intake-air system parts</li> <li>• Tumble swirl control system malfunction</li> <li>• Purge control solenoid malfunction</li> <li>• EGR valve malfunction</li> <li>• Brake dragging</li> <li>• Erratic signal from CKP sensor</li> <li>• Low engine compression</li> <li>• Vacuum leakage</li> <li>• Poor fuel quality</li> <li>• Spark leakage from high-tension leads</li> <li>• Air cleaner restriction</li> <li>• PCV valve malfunction</li> <li>• Improper valve timing due to jumping out of timing belt</li> <li>• Restriction in exhaust system</li> <li>• Intermittent open or short in fuel pump circuit</li> <li>• Inadequate fuel pressure</li> <li>• Fuel pump mechanical malfunction</li> <li>• Fuel leakage from fuel injector</li> <li>• Fuel injector clogging</li> <li>• Intermittent open or short of MAF sensor, TP sensor and VSS</li> <li>• ATX malfunction</li> <li>• Clutch slippage</li> </ul> <p><b>Warning</b>  <b>The following troubleshooting flow chart contains fuel system diagnosis and repair procedures. Read following warnings before performing fuel system services:</b></p> <ul style="list-style-type: none"> <li>• <b>Fuel vapor is hazardous. It can easily ignite, causing serious injury and damage. Always keep sparks and flames away from fuel.</b></li> <li>• <b>Fuel line spills and leakage are dangerous. Fuel can ignite and cause serious injuries or death and damage. Fuel can also irritate skin and eyes. To prevent this, always complete “BEFORE REPAIR PROCEDURE” and “AFTER REPAIR PROCEDURE” described in this manual.</b>  <b>(See 01–14–4 BEFORE REPAIR PROCEDURE.)</b>  <b>(See 01–14–5 AFTER REPAIR PROCEDURE.)</b></li> </ul>

### Diagnostic procedure

STEP	INSPECTION	ACTION				
1	<ul style="list-style-type: none"> <li>• Inspect for following:                             <ul style="list-style-type: none"> <li>— Vacuum connection</li> <li>— Air cleaner element</li> <li>— No air leakage from intake-air system</li> <li>— No restriction of intake-air system</li> <li>— Proper sealing of intake manifold and components attached to intake manifold: EGR valve, IAC valve</li> <li>— Fuel quality: proper octane, contamination, winter/summer blend</li> </ul> </li> <li>• Are all items okay?</li> </ul>	<table border="1" style="width: 100%; border-collapse: collapse;"> <tr> <td style="text-align: center; width: 10%;">Yes</td> <td>Go to next step.</td> </tr> <tr> <td style="text-align: center;">No</td> <td>Service as necessary. Repeat Step 1.</td> </tr> </table>	Yes	Go to next step.	No	Service as necessary. Repeat Step 1.
Yes	Go to next step.					
No	Service as necessary. Repeat Step 1.					
2	<ul style="list-style-type: none"> <li>• Connect WDS or equivalent to DLC-2.</li> <li>• Turn ignition switch on.</li> <li>• Retrieve any DTC.</li> <li>• Is “DTC” displayed?</li> </ul>	<table border="1" style="width: 100%; border-collapse: collapse;"> <tr> <td style="text-align: center; width: 10%;">Yes</td> <td><b>DTC is displayed:</b> <ul style="list-style-type: none"> <li>• Go to appropriate DTC test.</li> </ul> </td> </tr> <tr> <td style="text-align: center;">No</td> <td><b>No DTC is displayed:</b> <ul style="list-style-type: none"> <li>• Go to next step.</li> </ul> </td> </tr> </table>	Yes	<b>DTC is displayed:</b> <ul style="list-style-type: none"> <li>• Go to appropriate DTC test.</li> </ul>	No	<b>No DTC is displayed:</b> <ul style="list-style-type: none"> <li>• Go to next step.</li> </ul>
Yes	<b>DTC is displayed:</b> <ul style="list-style-type: none"> <li>• Go to appropriate DTC test.</li> </ul>					
No	<b>No DTC is displayed:</b> <ul style="list-style-type: none"> <li>• Go to next step.</li> </ul>					
3	<ul style="list-style-type: none"> <li>• Is engine overheating?</li> </ul>	<table border="1" style="width: 100%; border-collapse: collapse;"> <tr> <td style="text-align: center; width: 10%;">Yes</td> <td>Go to symptom troubleshooting “NO.17 COOLING SYSTEM CONCERNS — OVERHEATING [ZM]”.</td> </tr> <tr> <td style="text-align: center;">No</td> <td>Go to next step.</td> </tr> </table>	Yes	Go to symptom troubleshooting “NO.17 COOLING SYSTEM CONCERNS — OVERHEATING [ZM]”.	No	Go to next step.
Yes	Go to symptom troubleshooting “NO.17 COOLING SYSTEM CONCERNS — OVERHEATING [ZM]”.					
No	Go to next step.					

## SYMPTOM TROUBLESHOOTING [ENGINE CONTROL SYSTEM (ZM)]

STEP	INSPECTION	ACTION	
4	<ul style="list-style-type: none"> <li>Connect WDS or equivalent to DLC-2.</li> <li>Access RPM PID, MAF PID, TP PID, and VSS PID.</li> <li>Drive vehicle with monitoring PIDs.</li> <li>Are PIDs within specification? (See 01-40A-7 PCM Inspection Using the SST (WDS or equivalent).)</li> </ul>	Yes	Go to next step.
		No	<b>RPM PID:</b> <ul style="list-style-type: none"> <li>Inspect CKP sensor and related harness for vibration and/or intermittent open/short circuit.</li> </ul> <b>MAF PID:</b> <ul style="list-style-type: none"> <li>Inspect for intermittent open circuit of MAF sensor and related wire harness.</li> </ul> <b>TP PID:</b> <ul style="list-style-type: none"> <li>Inspect if TP sensor output increases smoothly.</li> </ul> <b>VSS PID:</b> <ul style="list-style-type: none"> <li>Inspect for intermittent open circuit of VSS and related wire harness.</li> </ul>
5	<ul style="list-style-type: none"> <li>Visually inspect CKP sensor and teeth of crankshaft pulley.</li> <li>Are CKP sensor and teeth of crankshaft pulley okay?</li> </ul>	Yes	Go to next step.
		No	Replace malfunctioning parts.
6	<ul style="list-style-type: none"> <li>Measure gap between CKP sensor and teeth of crankshaft pulley.</li> </ul> <b>Gap</b> <b>0.5—1.5 mm {0.020—0.059 in}</b> <ul style="list-style-type: none"> <li>Is the gap within specification?</li> </ul>	Yes	Go to next step.
		No	Adjust CKP sensor.
7	<ul style="list-style-type: none"> <li>Inspect condition of spark plugs.</li> <li>Is spark plug wet, covered with carbon or grayish white?</li> </ul>	Yes	<b>Spark plug is wet or covered with carbon:</b> <ul style="list-style-type: none"> <li>Inspect for fuel leakage from fuel injector.</li> </ul> <b>Spark plug is grayish white:</b> <ul style="list-style-type: none"> <li>Inspect for clogged fuel injector.</li> </ul>
		No	Install spark plugs on original cylinders. Go to next step.
8	<ul style="list-style-type: none"> <li>Remove and shake PCV valve.</li> <li>Does PCV valve rattle?</li> </ul>	Yes	Go to next step.
		No	Replace PCV valve.
9	<ul style="list-style-type: none"> <li>Is there restriction in exhaust system?</li> </ul>	Yes	Inspect exhaust system.
		No	Go to next step.
10	<ul style="list-style-type: none"> <li>Install fuel pressure gauge between fuel filter and fuel distributor.</li> <li>Connect jumper wire between F/P terminal at DLC in engine compartment and GND.</li> <li>Turn ignition switch on.</li> <li>Is fuel line pressure correct with ignition switch on?</li> </ul> <b>Fuel line pressure</b> <b>270—310 kPa {2.7—3.2 kgf/cm<sup>2</sup>, 39—45 psi}</b>	Yes	Go to next step.
		No	<b>Zero or low:</b> <ul style="list-style-type: none"> <li>Inspect fuel pump circuit.</li> <li>Inspect for open fuel pump relief valve.</li> <li>Inspect for fuel leakage inside pressure regulator.</li> <li>Inspect for clogged main fuel line.</li> </ul> <b>High:</b> <ul style="list-style-type: none"> <li>Inspect pressure regulator for high pressure cause.</li> <li>Inspect for clogged fuel return line.</li> </ul>
11	<ul style="list-style-type: none"> <li>Inspect for tumble swirl control system operation. (See 01-03A-58 Variable Tumble Control System (VTCS) Inspection.)</li> <li>Does tumble swirl control system work properly?</li> </ul>	Yes	Go to next step.
		No	Repair or replace malfunctioning parts.
12	<b>Note</b> <ul style="list-style-type: none"> <li>Following test is for engine stalling with A/C on concern. If other symptoms exist, go to next step.</li> <li>Connect pressure gauge to A/C low and high side pressure lines.</li> <li>Turn A/C on and measure low side and high side pressure.</li> <li>Are pressure within specifications? (See 07-10-3 REFRIGERANT PRESSURE CHECK.)</li> </ul>	Yes	Go to next step.
		No	If A/C is always on, go to symptom troubleshooting "NO.24 A/C IS ALWAYS ON/ A/C COMPRESSOR RUNS CONTINUOUSLY [ZM]". For other symptoms, inspect following: <ul style="list-style-type: none"> <li>Refrigerant charging amount</li> <li>Condenser fan operation</li> </ul>

01-03A



## SYMPTOM TROUBLESHOOTING [ENGINE CONTROL SYSTEM (ZM)]

STEP	INSPECTION	ACTION	
13	<ul style="list-style-type: none"> <li>Disconnect vacuum hose between purge solenoid valve and intake manifold from purge solenoid valve side.</li> <li>Plug opening end of vacuum hose.</li> <li>Drive vehicle.</li> <li>Does engine condition improve?</li> </ul>	Yes	Inspect if purge solenoid valve sticks open mechanically. Inspect evaporative emission control system.
		No	Go to next step.
14	<ul style="list-style-type: none"> <li>Visually inspect CMP sensor and projections of camshaft pulley.</li> <li>Are CMP sensor and projections of camshaft pulley okay?</li> </ul>	Yes	Go to next step.
		No	Replace malfunctioning parts.
15	<ul style="list-style-type: none"> <li>Inspect EGR valve.</li> <li>Is EGR valve okay?</li> </ul>	Yes	Go to next step.
		No	Replace malfunctioning parts.
16	<ul style="list-style-type: none"> <li>Is engine compression correct?</li> </ul>	Yes	Inspect following: <ul style="list-style-type: none"> <li>Valve timing</li> <li>Internal transaxle components (ATX)</li> <li>Clutch (MTX)</li> <li>Brake system for dragging</li> </ul>
		No	Inspect for cause.
17	<ul style="list-style-type: none"> <li>Verify test results. <ul style="list-style-type: none"> <li>If okay, return to diagnostic index to service any additional symptoms.</li> <li>If malfunction remains, refer to related Service Bulletins and perform repair or diagnosis. <ul style="list-style-type: none"> <li>If vehicle is repaired, troubleshooting completed.</li> <li>If vehicle is not repaired or additional diagnostic information is not available, replace PCM.</li> </ul> </li> </ul> </li> </ul>		

### NO.13 KNOCKING/PINGING-ACCELERATION/CRUISE [ZM]

A3U010318881W55

13	Knocking/pinging — acceleration/cruise
<b>DESCRIPTION</b>	<ul style="list-style-type: none"> <li>Sound is produced when air/fuel mixture is ignited by something other than spark plug (e.g., hot spot in combustion chamber).</li> </ul>
<b>POSSIBLE CAUSE</b>	<ul style="list-style-type: none"> <li>Engine overheating due to cooling system malfunction</li> <li>ECT sensor malfunction</li> <li>IAT sensor malfunction</li> <li>Inadequate engine compression</li> <li>Inadequate fuel pressure</li> </ul> <p><b>Warning</b>  The following troubleshooting flowchart contains fuel system diagnosis and repair procedures. Read following warnings before performing fuel system services:</p> <ul style="list-style-type: none"> <li>Fuel vapor is hazardous. It can easily ignite, causing serious injury and damage. Always keep sparks and flames away from fuel.</li> <li>Fuel line spills and leakage are dangerous. Fuel can ignite and cause serious injuries or death and damage. Fuel can also irritate skin and eyes. To prevent this, always complete "BEFORE REPAIR PROCEDURE" and "AFTER REPAIR PROCEDURE" described in this manual.  (See 01-14-4 BEFORE REPAIR PROCEDURE.)  (See 01-14-5 AFTER REPAIR PROCEDURE.)</li> </ul>

#### Diagnostic procedure

STEP	INSPECTION	ACTION	
1	<ul style="list-style-type: none"> <li>Connect WDS or equivalent to DLC-2.</li> <li>Access ECT PID.</li> <li>Verify ECT PID is <b>less than 116 °C {241 °F}</b> during driving.</li> <li>Is ECT PID less than specification?</li> </ul>	Yes	Go to next step.
		No	Inspect cooling system for cause of overheating.
2	<ul style="list-style-type: none"> <li>Connect WDS or equivalent to DLC-2.</li> <li>Turn ignition switch on.</li> <li>Retrieve any DTC.</li> <li>Is "DTC" displayed?</li> </ul>	Yes	<b>DTC is displayed:</b> <ul style="list-style-type: none"> <li>Go to appropriate DTC test.</li> </ul>
		No	<b>No DTC is displayed:</b> <ul style="list-style-type: none"> <li>Go to next step.</li> </ul>
3	<ul style="list-style-type: none"> <li>Is engine compression correct?</li> </ul>	Yes	Go to next step.
		No	Inspect for cause.

## SYMPTOM TROUBLESHOOTING [ENGINE CONTROL SYSTEM (ZM)]

STEP	INSPECTION	ACTION				
4	<ul style="list-style-type: none"> <li>• Install fuel pressure gauge between fuel filter and fuel distributor.</li> <li>• Start engine and run it at idle.</li> <li>• Measure fuel line pressure at idle.</li> <li>• Is fuel line pressure correct at idle?</li> </ul> <p><b>Fuel line pressure</b> 210—250 kPa {2.1—2.6 kgf/cm<sup>2</sup>, 30—36 psi}</p>	<table border="0" style="width: 100%;"> <tr> <td style="width: 50px; text-align: center;">Yes</td> <td>Go to next step.</td> </tr> <tr> <td style="text-align: center;">No</td> <td> <p><b>Zero or low:</b></p> <ul style="list-style-type: none"> <li>• Inspect fuel pump circuit.</li> <li>• Inspect for open fuel pump relief valve.</li> <li>• Inspect for fuel leakage inside pressure regulator.</li> <li>• Inspect for clogged main fuel line.</li> </ul> <p><b>High:</b></p> <ul style="list-style-type: none"> <li>• Inspect pressure regulator for high pressure cause.</li> <li>• Inspect for clogged fuel return line.</li> </ul> </td> </tr> </table>	Yes	Go to next step.	No	<p><b>Zero or low:</b></p> <ul style="list-style-type: none"> <li>• Inspect fuel pump circuit.</li> <li>• Inspect for open fuel pump relief valve.</li> <li>• Inspect for fuel leakage inside pressure regulator.</li> <li>• Inspect for clogged main fuel line.</li> </ul> <p><b>High:</b></p> <ul style="list-style-type: none"> <li>• Inspect pressure regulator for high pressure cause.</li> <li>• Inspect for clogged fuel return line.</li> </ul>
Yes	Go to next step.					
No	<p><b>Zero or low:</b></p> <ul style="list-style-type: none"> <li>• Inspect fuel pump circuit.</li> <li>• Inspect for open fuel pump relief valve.</li> <li>• Inspect for fuel leakage inside pressure regulator.</li> <li>• Inspect for clogged main fuel line.</li> </ul> <p><b>High:</b></p> <ul style="list-style-type: none"> <li>• Inspect pressure regulator for high pressure cause.</li> <li>• Inspect for clogged fuel return line.</li> </ul>					
5	<ul style="list-style-type: none"> <li>• Verify test results.                             <ul style="list-style-type: none"> <li>— If okay, return to diagnostic index to service any additional symptoms.</li> <li>— If malfunction remains, refer to related Service Bulletins and perform repair or diagnosis.                                     <ul style="list-style-type: none"> <li>• If vehicle is repaired, troubleshooting completed.</li> <li>• If vehicle is not repaired or additional diagnostic information is not available, replace PCM.</li> </ul> </li> </ul> </li> </ul>					

01-03A

### NO.14 POOR FUEL ECONOMY [ZM]

A3U010318881W56

14	Poor fuel economy
<b>DESCRIPTION</b>	<ul style="list-style-type: none"> <li>• Fuel economy is unsatisfactory.</li> </ul>
<b>POSSIBLE CAUSE</b>	<ul style="list-style-type: none"> <li>• Contaminated air cleaner element</li> <li>• Tumble swirl control system malfunction</li> <li>• Engine cooling system malfunction</li> <li>• Improper ATX fluid level (ATX)</li> <li>• Weak spark</li> <li>• Poor fuel quality</li> <li>• Erratic or no signal from CMP sensor</li> <li>• Improper coolant level</li> <li>• Inadequate fuel pressure</li> <li>• Spark plug malfunction</li> <li>• PCV valve malfunction</li> <li>• Brake dragging</li> <li>• Improper valve timing due to jumping out of timing belt</li> <li>• Contaminated MAF sensor</li> <li>• Improper engine compression</li> <li>• Exhaust system clogging</li> </ul> <p><b>Warning</b> The following troubleshooting flowchart contains fuel system diagnosis and repair procedures. Read following warnings before performing fuel system services:</p> <ul style="list-style-type: none"> <li>• <b>Fuel vapor is hazardous. It can easily ignite, causing serious injury and damage. Always keep sparks and flames away from fuel.</b></li> <li>• <b>Fuel line spills and leakage are dangerous. Fuel can ignite and cause serious injuries or death and damage. Fuel can also irritate skin and eyes. To prevent this, always complete "BEFORE REPAIR PROCEDURE" and "AFTER REPAIR PROCEDURE" described in this manual.</b> (See 01-14-4 BEFORE REPAIR PROCEDURE.) (See 01-14-5 AFTER REPAIR PROCEDURE.)</li> </ul>

### Diagnostic procedure

STEP	INSPECTION	ACTION				
1	<ul style="list-style-type: none"> <li>• Inspect for following:                             <ul style="list-style-type: none"> <li>— Air cleaner element for contamination</li> <li>— Automatic transaxle fluid level</li> <li>— Fuel quality</li> <li>— Coolant level</li> </ul> </li> <li>• Are all items okay?</li> </ul>	<table border="0" style="width: 100%;"> <tr> <td style="width: 50px; text-align: center;">Yes</td> <td>Go to next step.</td> </tr> <tr> <td style="text-align: center;">No</td> <td>Service as necessary. Repeat Step 1.</td> </tr> </table>	Yes	Go to next step.	No	Service as necessary. Repeat Step 1.
Yes	Go to next step.					
No	Service as necessary. Repeat Step 1.					
2	<ul style="list-style-type: none"> <li>• Connect WDS or equivalent to DLC-2.</li> <li>• Turn ignition switch on.</li> <li>• Retrieve any DTC.</li> <li>• Is "DTC" displayed?</li> </ul>	<table border="0" style="width: 100%;"> <tr> <td style="width: 50px; text-align: center;">Yes</td> <td><b>DTC is displayed:</b> <ul style="list-style-type: none"> <li>• Go to appropriate DTC test.</li> </ul> </td> </tr> <tr> <td style="text-align: center;">No</td> <td><b>No DTC is displayed:</b> <ul style="list-style-type: none"> <li>• Go to next step.</li> </ul> </td> </tr> </table>	Yes	<b>DTC is displayed:</b> <ul style="list-style-type: none"> <li>• Go to appropriate DTC test.</li> </ul>	No	<b>No DTC is displayed:</b> <ul style="list-style-type: none"> <li>• Go to next step.</li> </ul>
Yes	<b>DTC is displayed:</b> <ul style="list-style-type: none"> <li>• Go to appropriate DTC test.</li> </ul>					
No	<b>No DTC is displayed:</b> <ul style="list-style-type: none"> <li>• Go to next step.</li> </ul>					
3	<ul style="list-style-type: none"> <li>• Access ECT PID.</li> <li>• Drive vehicle while monitoring PID. (See 01-40A-7 PCM Inspection Using the SST (WDS or equivalent).)</li> <li>• Is PID within specification?</li> </ul>	<table border="0" style="width: 100%;"> <tr> <td style="width: 50px; text-align: center;">Yes</td> <td>Go to next step.</td> </tr> <tr> <td style="text-align: center;">No</td> <td>Inspect for coolant leakage, cooling fan and condenser fan operations or thermostat operation.</td> </tr> </table>	Yes	Go to next step.	No	Inspect for coolant leakage, cooling fan and condenser fan operations or thermostat operation.
Yes	Go to next step.					
No	Inspect for coolant leakage, cooling fan and condenser fan operations or thermostat operation.					

## SYMPTOM TROUBLESHOOTING [ENGINE CONTROL SYSTEM (ZM)]

STEP	INSPECTION	ACTION
4	<ul style="list-style-type: none"> <li>Is strong blue spark visible at each disconnected high-tension lead while cranking engine?</li> </ul>	Yes Inspect for following: <ul style="list-style-type: none"> <li>Spark plugs malfunction</li> <li>CMP sensor is improperly installed.</li> <li>Trigger wheel damage on camshaft</li> <li>Open or short circuit on CMP sensor</li> <li>Open or short circuit between CMP sensor and PCM terminal 85</li> </ul> Repair or replace malfunctioning parts. <ul style="list-style-type: none"> <li>If okay, go to next step.</li> </ul>
		No Inspect following: <ul style="list-style-type: none"> <li>High-tension leads</li> <li>Ignition coil and connector</li> </ul>
5	<ul style="list-style-type: none"> <li>Install fuel pressure gauge between fuel filter and fuel distributor.</li> <li>Start engine and run it at idle.</li> <li>Measure fuel line pressure at idle.</li> <li>Is fuel line pressure correct at idle?</li> </ul> <p><b>Fuel line pressure</b> 210—250 kPa {2.1—2.6 kgf/cm<sup>2</sup>, 30—36 psi}</p>	Yes Go to next step.
		No <b>Zero or low:</b> <ul style="list-style-type: none"> <li>Inspect fuel pump circuit.</li> <li>Inspect for open fuel pump relief valve.</li> <li>Inspect for fuel leakage inside pressure regulator.</li> <li>Inspect for clogged main fuel line.</li> </ul> <b>High:</b> <ul style="list-style-type: none"> <li>Inspect pressure regulator for high pressure cause.</li> <li>Inspect for clogged fuel return line.</li> </ul>
6	<ul style="list-style-type: none"> <li>Inspect tumble swirl control system operation. (See 01-03A-58 Variable Tumble Control System (VTCS) Inspection.)</li> <li>Does tumble swirl control system work properly?</li> </ul>	Yes Go to next step.
		No Repair or replace malfunctioning parts.
7	<ul style="list-style-type: none"> <li>Remove and shake PCV valve.</li> <li>Does PCV valve rattle?</li> </ul>	Yes Go to next step.
		No Replace PCV valve.
8	<ul style="list-style-type: none"> <li>Is there any restriction in exhaust system?</li> </ul>	Yes Inspect exhaust system.
		No Go to next step.
9	<ul style="list-style-type: none"> <li>Is brake system functioning properly?</li> </ul>	Yes Go to next step.
		No Inspect for cause.
10	<ul style="list-style-type: none"> <li>Inspect for contaminated MAF sensor.</li> <li>Is there any contamination?</li> </ul>	Yes Replace MAF sensor.
		No Go to next step.
11	<ul style="list-style-type: none"> <li>Is engine compression correct?</li> </ul>	Yes Inspect valve timing.
		No Inspect for cause.
12	<ul style="list-style-type: none"> <li>Verify test results.                             <ul style="list-style-type: none"> <li>If okay, return to diagnostic index to service any additional symptoms.</li> <li>If malfunction remains, refer to related Service Bulletins and perform repair or diagnosis.                                     <ul style="list-style-type: none"> <li>If vehicle is repaired, troubleshooting completed.</li> <li>If vehicle is not repaired or additional diagnostic information is not available, replace PCM.</li> </ul> </li> </ul> </li> </ul>	

# SYMPTOM TROUBLESHOOTING [ENGINE CONTROL SYSTEM (ZM)]

## NO.15 EMISSION COMPLIANCE [ZM]

A3U010318881W57

01-03A

<b>15</b>	<b>Emission compliance</b>
<b>DESCRIPTION</b>	<ul style="list-style-type: none"> <li>Emission compliance test failed.</li> </ul>
<b>POSSIBLE CAUSE</b>	<ul style="list-style-type: none"> <li>Vacuum lines leakage or blockage</li> <li>Cooling system malfunction</li> <li>Spark plug malfunction</li> <li>Leakage from intake manifold</li> <li>Erratic or no signal from CMP sensor</li> <li>Inadequate fuel pressure</li> <li>PCV valve malfunction or incorrect valve installation</li> <li>EGR valve malfunction</li> <li>Exhaust system clogging</li> <li>Fuel tank ventilation system malfunction</li> <li>Charcoal canister damage</li> <li>Excessive carbon is built up in combustion chamber.</li> <li>Improper engine compression</li> <li>Improper valve timing</li> </ul> <p><b>Warning</b>  <b>The following troubleshooting flowchart contains fuel system diagnosis and repair procedures. Read following warnings before performing fuel system services:</b></p> <ul style="list-style-type: none"> <li>Fuel vapor is hazardous. It can easily ignite, causing serious injury and damage. Always keep sparks and flames away from fuel.</li> <li>Fuel line spills and leakage are dangerous. Fuel can ignite and cause serious injuries or death and damage. Fuel can also irritate skin and eyes. To prevent this, always complete "BEFORE REPAIR PROCEDURE" and "AFTER REPAIR PROCEDURE" described in this manual.                      (See 01-14-4 BEFORE REPAIR PROCEDURE.)                      (See 01-14-5 AFTER REPAIR PROCEDURE.)</li> </ul>

### Diagnostic procedure

STEP	INSPECTION		ACTION
1	<ul style="list-style-type: none"> <li>Inspect for following:                             <ul style="list-style-type: none"> <li>— Vacuum lines for leakage or blockage</li> <li>— Electrical connections</li> <li>— Proper maintenance schedule followed</li> <li>— Intake-air system and air cleaner element concerns: obstructions, leakage or dirtiness</li> </ul> </li> <li>Are all items okay?</li> </ul>	Yes	Go to next step.
		No	Service as necessary. Repeat Step 1.
2	<ul style="list-style-type: none"> <li>Connect WDS or equivalent to DLC-2.</li> <li>Turn ignition switch on.</li> <li>Retrieve any DTC.</li> <li>Is "DTC" displayed?</li> </ul>	Yes	<b>DTC is displayed:</b> <ul style="list-style-type: none"> <li>Go to next step.</li> </ul>
		No	<b>No DTC is displayed:</b> <ul style="list-style-type: none"> <li>Go to appropriate DTC test.</li> </ul>
3	<ul style="list-style-type: none"> <li>Is any other drivability concern present?</li> </ul>	Yes	Go to appropriate symptom troubleshooting.
		No	Go to next step.
4	<ul style="list-style-type: none"> <li>Connect WDS or equivalent to DLC-2.</li> <li>Access ECT PID.</li> <li>Warm up engine and run it at idle.</li> <li>Verify ECT PID is correct.</li> <li>Is ECT PID correct?</li> </ul>	Yes	Go to next step.
		No	Inspect for coolant leakage, cooling fan and condenser fan operation or thermostat operation.
5	<ul style="list-style-type: none"> <li>Is strong blue spark visible at each disconnected high-tension lead while cranking engine?</li> </ul>	Yes	Inspect for following: <ul style="list-style-type: none"> <li>Spark plugs malfunction</li> <li>CMP sensor is improperly installed.</li> <li>Damage of trigger wheel on camshaft</li> <li>Open or short circuit on CMP sensor</li> <li>Open or short circuit between CMP sensor and PCM terminal 85</li> </ul> Repair or replace malfunctioning parts. <ul style="list-style-type: none"> <li>If okay, go to next step.</li> </ul>
		No	Inspect following: <ul style="list-style-type: none"> <li>High-tension leads</li> <li>Ignition coil and connector</li> </ul>

## SYMPTOM TROUBLESHOOTING [ENGINE CONTROL SYSTEM (ZM)]

STEP	INSPECTION	ACTION	
6	<ul style="list-style-type: none"> <li>• Install fuel pressure gauge between fuel filter and fuel distributor.</li> <li>• Start engine and run it at idle.</li> <li>• Measure fuel line pressure at idle.</li> <li>• Is fuel line pressure correct at idle?</li> </ul> <p><b>Fuel line pressure</b> 210—250 kPa {2.1—2.6 kgf/cm<sup>2</sup>, 30—36 psi}</p>	Yes	Go to next step.
		No	<p><b>Zero or low:</b></p> <ul style="list-style-type: none"> <li>• Inspect fuel pump circuit.</li> <li>• Inspect for open fuel pump relief valve.</li> <li>• Inspect for fuel leakage inside pressure regulator.</li> <li>• Inspect for clogged main fuel line.</li> </ul> <p><b>High:</b></p> <ul style="list-style-type: none"> <li>• Inspect pressure regulator for high pressure cause.</li> <li>• Inspect for clogged fuel return line.</li> </ul>
7	<ul style="list-style-type: none"> <li>• Remove and shake PCV valve.</li> <li>• Does PCV valve rattle?</li> </ul>	Yes	Go to next step.
		No	Replace PCV valve.
8	<ul style="list-style-type: none"> <li>• Inspect for fuel saturation inside charcoal canister.</li> <li>• Is excess amount of liquid fuel present in canister?</li> </ul>	Yes	Replace charcoal canister.
		No	Inspect fuel tank vent system. Then, go to next step.
9	<ul style="list-style-type: none"> <li>• Is there any restriction in exhaust system?</li> </ul>	Yes	Inspect exhaust system.
		No	Inspect EGR valve.
10	<ul style="list-style-type: none"> <li>• Verify test results.                             <ul style="list-style-type: none"> <li>— If okay, return to diagnostic index to service any additional symptoms.</li> <li>— If malfunction remains, refer to related Service Bulletins and perform repair or diagnosis.                                     <ul style="list-style-type: none"> <li>• If vehicle is repaired, troubleshooting completed.</li> <li>• If vehicle is not repaired or additional diagnostic information is not available, replace PCM.</li> </ul> </li> </ul> </li> </ul>		

### NO.16 HIGH OIL CONSUMPTION/LEAKAGE [ZM]

A3U010318881W58

<b>16</b>	<b>High oil consumption/leakage</b>
<b>DESCRIPTION</b>	<ul style="list-style-type: none"> <li>• Oil consumption is excessive.</li> </ul>
<b>POSSIBLE CAUSE</b>	<ul style="list-style-type: none"> <li>• PCV valve malfunction</li> <li>• Improper dipstick</li> <li>• Improper engine oil viscosity</li> <li>• Engine internal parts malfunction</li> </ul>

#### Diagnostic procedure

STEP	INSPECTION	ACTION	
1	<ul style="list-style-type: none"> <li>• Remove and shake PCV valve.</li> <li>• Does PCV valve rattle?</li> </ul>	Yes	Go to next step.
		No	Replace PCV valve.
2	<ul style="list-style-type: none"> <li>• Inspect for following:                             <ul style="list-style-type: none"> <li>— External leakage</li> <li>— Proper dipstick</li> <li>— Proper engine oil viscosity</li> </ul> </li> <li>• Are all items okay?</li> </ul>	Yes	Inspect internal engine parts such as valves, valve guides, valve stem seals, cylinder head drain passage, piston rings.
		No	Service as necessary. Repeat Step 2.
3	<ul style="list-style-type: none"> <li>• Verify test results.                             <ul style="list-style-type: none"> <li>— If okay, return to diagnostic index to service any additional symptoms.</li> <li>— If malfunction remains, refer to related Service Bulletins and perform repair or diagnosis.                                     <ul style="list-style-type: none"> <li>• If vehicle is repaired, troubleshooting completed.</li> <li>• If vehicle is not repaired or additional diagnostic information is not available, replace PCM.</li> </ul> </li> </ul> </li> </ul>		

# SYMPTOM TROUBLESHOOTING [ENGINE CONTROL SYSTEM (ZM)]

## NO.17 COOLING SYSTEM CONCERNS-OVERHEATING [ZM]

A3U010318881W59

<b>17</b>	<b>Cooling system concerns — overheating</b>
<b>DETECTION CONDITION</b>	<ul style="list-style-type: none"> <li>• Engine runs at higher than normal temperature/Overheats.</li> </ul>
<b>POSSIBLE CAUSE</b>	<ul style="list-style-type: none"> <li>• Improper coolant level</li> <li>• Blown fuses</li> <li>• Coolant leakage</li> <li>• Excessive A/C system pressure</li> <li>• Improper water/anti-freeze mixture</li> <li>• Fans reverse rotation</li> <li>• Poor radiator condition</li> <li>• Thermostat malfunction</li> <li>• Radiator hoses damage</li> <li>• Condenser fan is inoperative.</li> <li>• Improper or damaged radiator cap</li> <li>• Cooling fan is inoperative.</li> <li>• Coolant overflow system malfunction</li> <li>• Improper tension of drive belt</li> <li>• Drive belt damage</li> </ul>

01-03A

### Diagnostic procedure

STEP	INSPECTION	ACTION	
1	<ul style="list-style-type: none"> <li>• Inspect following:                             <ul style="list-style-type: none"> <li>— Engine coolant level</li> <li>— Coolant leakage</li> <li>— Water and anti-freeze mixture</li> <li>— Radiator condition</li> <li>— Collapsed or restricted radiator hoses</li> <li>— Radiator pressure cap</li> <li>— Overflow system</li> <li>— Fan rotational direction</li> <li>— Fuses</li> </ul> </li> <li>• Are all items okay?</li> </ul>	Yes	Go to next step.
		No	Service as necessary. Repeat Step 1.
2	<ul style="list-style-type: none"> <li>• Connect WDS or equivalent to DLC-2.</li> <li>• Turn ignition key to ON.</li> <li>• Retrieve any DTC.</li> <li>• Is "DTC" displayed?</li> </ul>	Yes	<b>DTC is displayed:</b> <ul style="list-style-type: none"> <li>• Go to appropriate DTC test.</li> </ul>
		No	<b>No DTC is displayed:</b> <ul style="list-style-type: none"> <li>• Go to next step.</li> </ul>
3	<ul style="list-style-type: none"> <li>• Start engine and run it at idle speed.</li> <li>• Turn A/C switch on.</li> <li>• Does A/C compressor engage?</li> </ul>	Yes	Go to next step.
		No	Inspect following and repair or replace as necessary: <ul style="list-style-type: none"> <li>• Refrigerant charging amount</li> <li>• Open circuit between A/C relay and PCM terminal 96</li> <li>• Seized A/C magnetic clutch</li> <li>• A/C magnetic clutch malfunction                                     <ul style="list-style-type: none"> <li>— If all items are okay, go to inspect following.</li> </ul> </li> <li>• Refrigerant pressure switch operation</li> <li>• Evaporator temperature sensor and A/C amplifier</li> <li>• A/C switch is stuck open.</li> <li>• Open or short circuit between refrigerant pressure switch and PCM terminal 41</li> <li>• Open circuit of blower motor fan switch and resistor (if blower motor does not operate)</li> </ul>

## SYMPTOM TROUBLESHOOTING [ENGINE CONTROL SYSTEM (ZM)]

STEP	INSPECTION	ACTION	
4	<ul style="list-style-type: none"> <li>• Start engine and run it at idle speed.</li> <li>• Turn A/C switch on.</li> <li>• Do cooling fan and condenser fan operate?</li> </ul>	Yes	Go to next step.
		No	<b>Cooling fan motor does not operate:</b> <ul style="list-style-type: none"> <li>• Inspect for following:                             <ul style="list-style-type: none"> <li>— Cooling fan relay is stuck open.</li> <li>— Cooling fan motor malfunction</li> <li>— Cooling fan motor GND open</li> <li>— Open circuit between cooling fan motor and relay</li> <li>— Open circuit between cooling fan relay and PCM terminal 47</li> <li>— Open battery power circuit for cooling fan relay</li> </ul> </li> </ul> <b>Condenser fan motor does not operate:</b> <ul style="list-style-type: none"> <li>• Inspect for following:                             <ul style="list-style-type: none"> <li>— Condenser fan relay is stuck open.</li> <li>— Condenser fan motor malfunction</li> <li>— Condenser fan motor GND open</li> <li>— Open circuit between condenser fan motor and relay</li> <li>— Open circuit between condenser fan relay and PCM terminal 45</li> <li>— Open battery power circuit for condenser fan relay</li> </ul> </li> </ul>
5	<ul style="list-style-type: none"> <li>• Is drive belt okay?</li> </ul>	Yes	Go to next step.
		No	Replace drive belt.
6	<ul style="list-style-type: none"> <li>• Is there any leakage around heater unit in passenger compartment?</li> </ul>	Yes	Inspect and service heater for leakage.
		No	Go to next step.
7	<ul style="list-style-type: none"> <li>• Is there any leakage at coolant hoses and/or radiator?</li> </ul>	Yes	Replace malfunctioning part.
		No	Go to next step.
8	<ul style="list-style-type: none"> <li>• Cool down the engine.</li> <li>• Remove thermostat and inspect operation. (See 01-12-5 THERMOSTAT REMOVAL/INSTALLATION.) (See 01-12-7 THERMOSTAT INSPECTION.)</li> <li>• Is thermostat okay?</li> </ul>	Yes	Engine coolant temperature and thermostat are okay, inspect engine block for leakage or blockage.
		No	Access ECT PID on WDS or equivalent. Inspect for both ECT and temperature gauge readings. <ul style="list-style-type: none"> <li>• If temperature gauge on instrument cluster indicates normal range but ECT is not same as temperature gauge reading, inspect ECT sensor.</li> <li>• If temperature gauge on instrument cluster indicates overheating but ECT is normal, inspect temperature gauge and heat gauge unit.</li> </ul>
9	<ul style="list-style-type: none"> <li>• Verify test results.                             <ul style="list-style-type: none"> <li>— If okay, return to diagnostic index to service any additional symptoms.</li> <li>— If malfunction remains, inspect related Service Bulletins and perform repair or diagnosis.                                     <ul style="list-style-type: none"> <li>• If vehicle is repaired, troubleshooting is completed.</li> <li>• If vehicle is not repaired or additional diagnostic information is not available, replace PCM.</li> </ul> </li> </ul> </li> </ul>		

### NO.18 COOLING SYSTEM CONCERNS-RUNS COLD [ZM]

A3U010318881W60

<b>18</b>	<b>Cooling system concerns — runs cold</b>
<b>DETECTION CONDITION</b>	<ul style="list-style-type: none"> <li>• Engine takes excessive period for reaching normal operating temperature.</li> </ul>
<b>POSSIBLE CAUSE</b>	<ul style="list-style-type: none"> <li>• Thermostat malfunction</li> <li>• Condenser fan system malfunction</li> <li>• Cooling fan system malfunction</li> </ul>

#### Diagnostic procedure

STEP	INSPECTION	ACTION	
1	<ul style="list-style-type: none"> <li>• Is customer complaint "Lack of passenger compartment heat" only?</li> </ul>	Yes	Inspect A/C and heater system.
		No	Go to next step.
2	<ul style="list-style-type: none"> <li>• Does engine speed continue at fast idle?</li> </ul>	Yes	Go to symptom troubleshooting "NO.9 FAST IDLE/RUNS ON [ZM]".
		No	Go to next step.

## SYMPTOM TROUBLESHOOTING [ENGINE CONTROL SYSTEM (ZM)]

STEP	INSPECTION	ACTION				
3	<ul style="list-style-type: none"> <li>• Remove thermostat and inspect operation. (See 01-12-5 THERMOSTAT REMOVAL/INSTALLATION.) (See 01-12-7 THERMOSTAT INSPECTION.)</li> <li>• Is thermostat okay?</li> </ul>	<table border="1" style="width: 100%; border-collapse: collapse;"> <tr> <td style="text-align: center; width: 50px;">Yes</td> <td style="padding-left: 10px;">                     Inspect cooling fan and condenser fan operation.                     <ul style="list-style-type: none"> <li>• If both or either fan operate abnormally, inspect for following:                             <ul style="list-style-type: none"> <li>— Cooling fan relay is stuck closed.</li> <li>— Condenser fan relay is stuck closed.</li> <li>— Short to GND between cooling fan relay and PCM terminal 47</li> <li>— Short to GND between condenser fan relay and PCM terminal 45</li> <li>— Circuit between cooling fan relay and fan motor shorts to battery supply line</li> <li>— Circuit between condenser fan relay and fan motor shorts to battery supply line</li> </ul> </li> </ul> </td> </tr> <tr> <td style="text-align: center;">No</td> <td style="padding-left: 10px;">                     Access ECT PID on WDS or equivalent. Inspect both ECT and temperature gauge on instrument cluster readings.                     <ul style="list-style-type: none"> <li>• If temperature gauge on instrument cluster indicates normal range but ECT is not same as temperature gauge reading, inspect ECT sensor.</li> <li>• If temperature gauge on instrument cluster indicates cold range but ECT is normal, inspect temperature gauge and heat gauge unit.</li> </ul> </td> </tr> </table>	Yes	Inspect cooling fan and condenser fan operation. <ul style="list-style-type: none"> <li>• If both or either fan operate abnormally, inspect for following:                             <ul style="list-style-type: none"> <li>— Cooling fan relay is stuck closed.</li> <li>— Condenser fan relay is stuck closed.</li> <li>— Short to GND between cooling fan relay and PCM terminal 47</li> <li>— Short to GND between condenser fan relay and PCM terminal 45</li> <li>— Circuit between cooling fan relay and fan motor shorts to battery supply line</li> <li>— Circuit between condenser fan relay and fan motor shorts to battery supply line</li> </ul> </li> </ul>	No	Access ECT PID on WDS or equivalent. Inspect both ECT and temperature gauge on instrument cluster readings. <ul style="list-style-type: none"> <li>• If temperature gauge on instrument cluster indicates normal range but ECT is not same as temperature gauge reading, inspect ECT sensor.</li> <li>• If temperature gauge on instrument cluster indicates cold range but ECT is normal, inspect temperature gauge and heat gauge unit.</li> </ul>
Yes	Inspect cooling fan and condenser fan operation. <ul style="list-style-type: none"> <li>• If both or either fan operate abnormally, inspect for following:                             <ul style="list-style-type: none"> <li>— Cooling fan relay is stuck closed.</li> <li>— Condenser fan relay is stuck closed.</li> <li>— Short to GND between cooling fan relay and PCM terminal 47</li> <li>— Short to GND between condenser fan relay and PCM terminal 45</li> <li>— Circuit between cooling fan relay and fan motor shorts to battery supply line</li> <li>— Circuit between condenser fan relay and fan motor shorts to battery supply line</li> </ul> </li> </ul>					
No	Access ECT PID on WDS or equivalent. Inspect both ECT and temperature gauge on instrument cluster readings. <ul style="list-style-type: none"> <li>• If temperature gauge on instrument cluster indicates normal range but ECT is not same as temperature gauge reading, inspect ECT sensor.</li> <li>• If temperature gauge on instrument cluster indicates cold range but ECT is normal, inspect temperature gauge and heat gauge unit.</li> </ul>					
4	<ul style="list-style-type: none"> <li>• Verify test results.                             <ul style="list-style-type: none"> <li>— If okay, return to diagnostic index to service any additional symptoms.</li> <li>— If malfunction remains, inspect related Service Bulletins and perform repair or diagnosis.                                     <ul style="list-style-type: none"> <li>• If vehicle is repaired, troubleshooting is completed.</li> <li>• If vehicle is not repaired or additional diagnostic information is not available, replace PCM.</li> </ul> </li> </ul> </li> </ul>					

01-03A

### NO.19 EXHAUST SMOKE [ZM]

A3U010318881W61

19	Exhaust smoke
<b>DESCRIPTION</b>	<ul style="list-style-type: none"> <li>• Blue, black, or white smoke from exhaust system</li> </ul>
<b>POSSIBLE CAUSE</b>	<p><b>Blue smoke (Burning oil):</b></p> <ul style="list-style-type: none"> <li>• PCV valve malfunction</li> <li>• Engine internal oil leakage</li> </ul> <p><b>White smoke (Water in combustion):</b></p> <ul style="list-style-type: none"> <li>• Cooling system malfunction (coolant loss)</li> <li>• Engine internal coolant leakage</li> </ul> <p><b>Black smoke (Rich fuel mixture):</b></p> <ul style="list-style-type: none"> <li>• Air cleaner restriction</li> <li>• Intake-air system is collapsed or restricted.</li> <li>• Fuel return line is restricted.</li> <li>• Excessive fuel pressure</li> <li>• Improper engine compression</li> <li>• Injector fuel leakage</li> <li>• Ignition system malfunction</li> </ul> <p><b>Warning</b>                      The following troubleshooting flowchart contains fuel system diagnosis and repair procedures. Read following warnings before performing fuel system services:</p> <ul style="list-style-type: none"> <li>• Fuel vapor is hazardous. It can easily ignite, causing serious injury and damage. Always keep sparks and flames away from fuel.</li> <li>• Fuel line spills and leakage are dangerous. Fuel can ignite and cause serious injuries or death and damage. Fuel can also irritate skin and eyes. To prevent this, always complete "BEFORE REPAIR PROCEDURE" and "AFTER REPAIR PROCEDURE" described in this manual.                      (See 01-14-4 BEFORE REPAIR PROCEDURE.)                      (See 01-14-5 AFTER REPAIR PROCEDURE.)</li> </ul>



## SYMPTOM TROUBLESHOOTING [ENGINE CONTROL SYSTEM (ZM)]

### Diagnostic procedure

STEP	INSPECTION	ACTION	
1	<ul style="list-style-type: none"> <li>• What color is smoke coming from exhaust system?</li> </ul>	Blue	Burning oil is indicated. Go to next step.
		White	Water in combustion is indicated. Go to Step 3.
		Black	Rich fuel mixture is indicated. Go to Step 4.
2	<ul style="list-style-type: none"> <li>• Remove and shake PCV valve.</li> <li>• Does PCV valve rattle?</li> </ul>	Yes	Inspect for following: <ul style="list-style-type: none"> <li>• Damaged valve guide, stems or valve seals</li> <li>• Blocked oil drain passage in cylinder head</li> <li>• Piston rings for not seated, seized or worn</li> <li>• Damaged cylinder bore</li> <li>— If other drivability symptoms are present, return to diagnostic index to service any additional symptoms.</li> </ul>
		No	Replace PCV valve.
3	<ul style="list-style-type: none"> <li>• Does cooling system hold pressure?</li> </ul>	Yes	Inspect for following: <ul style="list-style-type: none"> <li>• Cylinder head gasket leakage</li> <li>• Intake manifold gasket leakage</li> <li>• Engine block cracks or porosity</li> <li>— If other driveability symptoms are present, return to diagnostic index to service any additional symptoms.</li> </ul>
		No	Inspect for cause.
4	<ul style="list-style-type: none"> <li>• Inspect for following:                             <ul style="list-style-type: none"> <li>— Air cleaner restriction</li> <li>— Collapsed or restricted intake-air system</li> <li>— restricted fuel return line</li> </ul> </li> <li>• Are all items okay?</li> </ul>	Yes	Go to next step.
		No	Service as necessary. Repeat Step 4.
5	<ul style="list-style-type: none"> <li>• Connect WDS or equivalent to DLC-2.</li> <li>• Turn ignition switch on. Retrieve any DTC.</li> <li>• Is "DTC" displayed?</li> </ul>	Yes	<b>DTC is displayed:</b> <ul style="list-style-type: none"> <li>• Go to appropriate DTC test.</li> </ul>
		No	<b>No DTC is displayed:</b> <ul style="list-style-type: none"> <li>• Go to next step.</li> </ul>
6	<ul style="list-style-type: none"> <li>• Install fuel pressure gauge between fuel filter and fuel distributor.</li> <li>• Start engine and run it at idle.</li> <li>• Measure fuel line pressure at idle.</li> <li>• Is fuel line pressure correct at idle?</li> </ul> <p><b>Fuel line pressure</b> <b>210—250 kPa {2.1—2.6 kgf/cm<sup>2</sup>, 30—36 psi}</b></p>	Yes	Go to next step.
		No	<b>Zero or low:</b> <ul style="list-style-type: none"> <li>• Inspect fuel pump circuit.</li> <li>• Inspect for open fuel pump relief valve.</li> <li>• Inspect for fuel leakage inside pressure regulator.</li> <li>• Inspect for clogged main fuel line.</li> </ul> <b>High:</b> <ul style="list-style-type: none"> <li>• Inspect pressure regulator for high pressure cause.</li> <li>• Inspect for clogged fuel return line.</li> </ul>
7	<ul style="list-style-type: none"> <li>• Is strong blue spark visible at each disconnected high-tension lead while cranking engine?</li> </ul>	Yes	Inspect spark plugs and CMP sensor.
		No	Inspect following: <ul style="list-style-type: none"> <li>• High-tension leads</li> <li>• Ignition coil and connector</li> </ul>
8	<ul style="list-style-type: none"> <li>• Verify test results.                             <ul style="list-style-type: none"> <li>— If okay, return to diagnostic index to service any additional symptoms.</li> <li>— If malfunction remains, refer to related Service Bulletins and perform repair or diagnosis.                                     <ul style="list-style-type: none"> <li>• If vehicle is repaired, troubleshooting completed.</li> <li>• If vehicle is not repaired or additional diagnostic information is not available, replace PCM.</li> </ul> </li> </ul> </li> </ul>		

# SYMPTOM TROUBLESHOOTING [ENGINE CONTROL SYSTEM (ZM)]

## NO.20 FUEL ODOR (IN ENGINE COMPARTMENT) [ZM]

A3U010318881W62

<b>20</b>	<b>Fuel odor (in engine compartment)</b>
<b>DESCRIPTION</b>	<ul style="list-style-type: none"> <li>• Gasoline fuel smell or visible leakage</li> </ul>
<b>POSSIBLE CAUSE</b>	<ul style="list-style-type: none"> <li>• Excessive fuel pressure</li> <li>• Purge solenoid valve malfunction</li> <li>• Fuel tank vent system blockage</li> <li>• Charcoal canister malfunction</li> </ul> <p><b>Warning</b>  <b>The following troubleshooting flowchart contains fuel system diagnosis and repair procedures. Read following warnings before performing fuel system services:</b></p> <ul style="list-style-type: none"> <li>• <b>Fuel vapor is hazardous. It can easily ignite, causing serious injury and damage. Always keep sparks and flames away from fuel.</b></li> <li>• <b>Fuel line spills and leakage are dangerous. Fuel can ignite and cause serious injuries or death and damage. Fuel can also irritate skin and eyes. To prevent this, always complete "BEFORE REPAIR PROCEDURE" and "AFTER REPAIR PROCEDURE" described in this manual.</b>                      (See 01-14-4 BEFORE REPAIR PROCEDURE.)                      (See 01-14-5 AFTER REPAIR PROCEDURE.)</li> </ul>

01-03A

### Diagnostic procedure

STEP	INSPECTION		ACTION
1	<ul style="list-style-type: none"> <li>• Visually inspect for fuel leakage at fuel injector, O-ring, and fuel line.</li> <li>• Service as necessary.</li> <li>• Is fuel line pressure held after ignition switch is turned off? (See 01-14-28 Operation Inspection.)</li> </ul>	Yes	Go to next step.
		No	Inspect pressure regulator diaphragm condition. <ul style="list-style-type: none"> <li>• If condition is okay, inspect fuel injector.</li> <li>• If condition is not okay, replace pressure regulator.</li> </ul>
2	<ul style="list-style-type: none"> <li>• Inspect for blockage/restriction or open between engine vacuum port and charcoal canister.</li> <li>• Inspect for blockage in fuel tank vent system.</li> <li>• Is fault indicated?</li> </ul>	Yes	Replace vacuum hose.
		No	Go to next step.
3	<ul style="list-style-type: none"> <li>• Inspect purge solenoid valve. (See 01-16-12 PURGE SOLENOID VALVE INSPECTION.)</li> <li>• Is solenoid operating properly?</li> </ul>	Yes	Go to next step.
		No	Replace purge solenoid valve.
4	<ul style="list-style-type: none"> <li>• Connect WDS or equivalent to DLC-2.</li> <li>• Turn ignition switch on.</li> <li>• Retrieve any DTC.</li> <li>• Is "DTC" displayed?</li> </ul>	Yes	<b>No DTC is displayed:</b> <ul style="list-style-type: none"> <li>• Inspect charcoal canister for fuel saturation.</li> <li>• If excess amount of liquid fuel is present, replace charcoal canister.</li> </ul>
		No	<b>DTC is displayed:</b> <ul style="list-style-type: none"> <li>• Go to appropriate DTC test.</li> </ul>
5	<ul style="list-style-type: none"> <li>• Verify test results.                             <ul style="list-style-type: none"> <li>— If okay, return to diagnostic index to service any additional symptoms.</li> <li>— If malfunction remains, refer to related Service Bulletins and perform repair or diagnosis.                                     <ul style="list-style-type: none"> <li>• If vehicle is repaired, troubleshooting completed.</li> <li>• If vehicle is not repaired or additional diagnostic information is not available, replace PCM.</li> </ul> </li> </ul> </li> </ul>		

# SYMPTOM TROUBLESHOOTING [ENGINE CONTROL SYSTEM (ZM)]

## NO.21 ENGINE NOISE [ZM]

A3U010318881W63

<b>21</b>	<b>Engine noise</b>
<b>DESCRIPTION</b>	<ul style="list-style-type: none"> <li>• Engine noise from under hood</li> </ul>
<b>POSSIBLE CAUSE</b>	<p><b>Squeal, click or chirp noise:</b></p> <ul style="list-style-type: none"> <li>• Improper engine oil level</li> <li>• Improper drive belt tension</li> </ul> <p><b>Rattle sound noise:</b></p> <ul style="list-style-type: none"> <li>• Loose parts</li> </ul> <p><b>Hiss sound noise:</b></p> <ul style="list-style-type: none"> <li>• Vacuum leakage</li> <li>• Loose spark plug</li> <li>• Air leakage from intake-air system</li> </ul> <p><b>Rumble or grind noise:</b></p> <ul style="list-style-type: none"> <li>• Improper drive belt tension</li> </ul> <p><b>Rap or roar sound noise:</b></p> <ul style="list-style-type: none"> <li>• Exhaust system looseness</li> </ul> <p><b>Other noise:</b></p> <ul style="list-style-type: none"> <li>• Camshaft friction gear noise or MLA noise</li> </ul>

### Diagnostic procedure

STEP	INSPECTION		ACTION
1	<ul style="list-style-type: none"> <li>• Is squeal, click or chirp sound present?</li> </ul>	Yes	Inspect engine oil level or drive belts.
		No	Go to next step.
2	<ul style="list-style-type: none"> <li>• Is rumble or grind sound present?</li> </ul>	Yes	Inspect drive belt.
		No	Go to next step.
3	<ul style="list-style-type: none"> <li>• Is rattle sound present?</li> </ul>	Yes	Inspect location of rattle for loose parts.
		No	Go to next step.
4	<ul style="list-style-type: none"> <li>• Is hiss sound present?</li> </ul>	Yes	Inspect for following: <ul style="list-style-type: none"> <li>• Vacuum leakage</li> <li>• Spark plug looseness</li> <li>• Intake-air system leakage</li> </ul>
		No	Go to next step.
5	<ul style="list-style-type: none"> <li>• Is rap or roar sound present?</li> </ul>	Yes	Inspect exhaust system for loose parts.
		No	Go to next step.
6	<ul style="list-style-type: none"> <li>• Is knock sound present?</li> </ul>	Yes	Go to symptom troubleshooting "NO.13 KNOCKING/PINGING —ACCELERATION/CRUISE[ZM]".
		No	If noise comes from engine internal, inspect for friction gear or MLA noise.
7	<ul style="list-style-type: none"> <li>• Verify test results.                             <ul style="list-style-type: none"> <li>— If okay, return to diagnostic index to service any additional symptoms.</li> <li>— If malfunction remains, refer to related Service Bulletins and perform repair or diagnosis.                                     <ul style="list-style-type: none"> <li>• If vehicle is repaired, troubleshooting completed.</li> <li>• If vehicle is not repaired or additional diagnostic information is not available, replace PCM.</li> </ul> </li> </ul> </li> </ul>		

# SYMPTOM TROUBLESHOOTING [ENGINE CONTROL SYSTEM (ZM)]

## NO.22 VIBRATION CONCERNS (ENGINE) [ZM]

A3U010318881W64

<b>22</b>	<b>Vibration concerns (engine)</b>
<b>DESCRIPTION</b>	<ul style="list-style-type: none"> <li>• Vibration from under hood or driveline</li> </ul>
<b>POSSIBLE CAUSE</b>	<ul style="list-style-type: none"> <li>• Loose attaching bolts or worn parts</li> <li>• Components malfunction such as worn parts</li> </ul>

### Diagnostic procedure

STEP	INSPECTION	ACTION	
1	<ul style="list-style-type: none"> <li>• Inspect following components for loose attaching bolts or worn parts:                             <ul style="list-style-type: none"> <li>— Cooling fan</li> <li>— Drive belt and pulleys</li> <li>— Engine mounts</li> </ul> </li> <li>• Are all items okay?</li> </ul>	Yes	Inspect following systems: <ul style="list-style-type: none"> <li>• Wheels</li> <li>• Automatic transaxle</li> <li>• Driveline</li> <li>• Suspension</li> </ul>
		No	Readjust or retighten engine mount installation position. Service as necessary for other parts.
2	<ul style="list-style-type: none"> <li>• Verify test results.                             <ul style="list-style-type: none"> <li>— If okay, return to diagnostic index to service any additional symptoms.</li> <li>— If malfunction remains, refer to related Service Bulletins and perform repair or diagnosis.                                     <ul style="list-style-type: none"> <li>• If vehicle is repaired, troubleshooting completed.</li> <li>• If vehicle is not repaired or additional diagnostic information is not available, replace PCM.</li> </ul> </li> </ul> </li> </ul>		

01-03A

## NO.23 A/C DOES NOT WORK SUFFICIENTLY [ZM]

A3U010318881W65

<b>23</b>	<b>A/C does not work sufficiently.</b>
<b>DESCRIPTION</b>	<ul style="list-style-type: none"> <li>• A/C compressor magnetic clutch does not engage when A/C switch is turned on.</li> </ul>
<b>POSSIBLE CAUSE</b>	<ul style="list-style-type: none"> <li>• Improper refrigerant charging amount</li> <li>• Open A/C magnetic clutch</li> <li>• Open circuit between A/C relay and A/C magnetic clutch</li> <li>• Poor GND of A/C magnetic clutch</li> <li>• Refrigerant pressure switch is stuck open.</li> <li>• A/C relay is stuck open.</li> <li>• Seized A/C compressor</li> <li>• Open circuit between A/C switch and PCM through both refrigerant pressure switch and A/C amplifier</li> </ul>

### Diagnostic procedure

STEP	INSPECTION	ACTION	
1	<ul style="list-style-type: none"> <li>• Connect WDS or equivalent to DLC-2.</li> <li>• Turn ignition switch on.</li> <li>• Retrieve any DTC.</li> <li>• Is "DTC" displayed?</li> </ul>	Yes	<b>DTC is displayed:</b> <ul style="list-style-type: none"> <li>• Go to appropriate DTC test.</li> </ul>
		No	<b>No DTC is displayed:</b> <ul style="list-style-type: none"> <li>• Go to next step.</li> </ul>
2	<ul style="list-style-type: none"> <li>• Disconnect A/C compressor connector.</li> <li>• Start engine and turn A/C switch on.</li> <li>• Is there correct voltage at terminal of A/C compressor magnetic clutch connector?</li> </ul> <p><b>Specification More than 10.5 V</b></p>	Yes	Inspect for GND condition of magnetic clutch on A/C compressor. <ul style="list-style-type: none"> <li>• If GND condition is okay, inspect for open circuit of magnetic clutch coil.</li> </ul>
		No	Go to next step.
3	<ul style="list-style-type: none"> <li>• Disconnect refrigerant pressure switch connector.</li> <li>• Connect jumper wires between terminals of refrigerant pressure switch connector.</li> <li>• Turn ignition switch on.</li> <li>• Turn A/C switch on and set blower fan at any speed.</li> <li>• Does A/C work?</li> </ul>	Yes	Inspect refrigerant pressure switch operation. <ul style="list-style-type: none"> <li>• If switch is okay, go to next step.</li> </ul>
		No	Inspect for following: <ul style="list-style-type: none"> <li>• A/C switch is stuck open.</li> <li>• Open circuit between refrigerant pressure switch and PCM terminal 41</li> <li>• Open circuit of blower motor fan switch and resistor (if blower motor does not operate)</li> <li>• Evaporator temperature sensor and A/C amplifier</li> </ul>
4	<ul style="list-style-type: none"> <li>• Remove jumper wires from switch connector.</li> <li>• Reconnect connector to refrigerant pressure switch.</li> <li>• Start engine and turn A/C switch on.</li> <li>• Does fan operate?</li> </ul>	Yes	Inspect for stuck open A/C relay. Replace as necessary.
		No	Inspect following and repair or replace as necessary: <ul style="list-style-type: none"> <li>• Refrigerant charging amount</li> <li>• A/C compressor for being seized</li> </ul>

## SYMPTOM TROUBLESHOOTING [ENGINE CONTROL SYSTEM (ZM)]

STEP	INSPECTION	ACTION
5	<ul style="list-style-type: none"> <li>• Verify test results.                             <ul style="list-style-type: none"> <li>— If okay, return to diagnostic index to service any additional symptoms.</li> <li>— If malfunction remains, refer to related Service Bulletins and perform repair or diagnosis.                                     <ul style="list-style-type: none"> <li>• If vehicle is repaired, troubleshooting completed.</li> <li>• If vehicle is not repaired or additional diagnostic information is not available, replace PCM.</li> </ul> </li> </ul> </li> </ul>	

### NO.24 A/C IS ALWAYS ON/A/C COMPRESSOR RUNS CONTINUOUSLY [ZM]

A3U010318881W66

<b>24</b>	<b>A/C is always on/A/C compressor runs continuously.</b>
<b>DESCRIPTION</b>	<ul style="list-style-type: none"> <li>• A/C compressor magnetic clutch does not disengage.</li> </ul>
<b>POSSIBLE CAUSE</b>	<ul style="list-style-type: none"> <li>• Stuck engagement</li> <li>• A/C relay is stuck closed.</li> <li>• Short to GND between A/C switch and PCM</li> <li>• Short to GND circuit between A/C relay and PCM</li> <li>• A/C relay to magnetic clutch circuit shorts to battery power.</li> </ul>

#### Diagnostic procedure

STEP	INSPECTION	ACTION	
1	<ul style="list-style-type: none"> <li>• Connect WDS or equivalent to DLC-2.</li> <li>• Turn ignition switch on.</li> <li>• Retrieve any DTC.</li> <li>• Is "DTC" displayed?</li> </ul>	Yes	<b>DTC is displayed:</b> <ul style="list-style-type: none"> <li>• Go to appropriate DTC test.</li> </ul>
		No	<b>No DTC is displayed:</b> <ul style="list-style-type: none"> <li>• Go to next step.</li> </ul>
2	<ul style="list-style-type: none"> <li>• Start engine and run it at idle.</li> <li>• Turn A/C switch on.</li> <li>• Remove A/C relay.</li> <li>• Does A/C magnetic clutch disengage?</li> </ul>	Yes	Inspect for following: <ul style="list-style-type: none"> <li>• A/C relay is stuck closed.</li> <li>• Short to GND circuit between A/C relay and PCM terminal 96</li> </ul> — If both items are okay, go to next step.
		No	Inspect if circuit between A/C relay and magnetic clutch shorts to battery power circuit. <ul style="list-style-type: none"> <li>• If circuit is okay, inspect magnetic clutch stuck engagement or clearance.</li> </ul>
3	<ul style="list-style-type: none"> <li>• Disconnect refrigerant pressure switch connector.</li> <li>• Start engine and turn A/C switch on.</li> </ul> <p style="margin-left: 20px;"><b>Note</b></p> <ul style="list-style-type: none"> <li>• A/C should not work when disconnecting connector. If A/C remains working, short to GND circuit may be present.</li> </ul> <ul style="list-style-type: none"> <li>• Does A/C remain working?</li> </ul>	Yes	Inspect for short to GND circuit between refrigerant pressure switch and PCM terminal 41.
		No	Go to next step.
4	<ul style="list-style-type: none"> <li>• Reconnect refrigerant pressure switch connector.</li> <li>• Turn off A/C switch.</li> </ul> <p style="margin-left: 20px;"><b>Note</b></p> <ul style="list-style-type: none"> <li>• A/C should not work when turning the A/C switch off. If A/C remains working, short to GND circuit may be present.</li> </ul> <ul style="list-style-type: none"> <li>• Does A/C remain working?</li> </ul>	Yes	Inspect following: <ul style="list-style-type: none"> <li>• Short to GND circuit between A/C switch and A/C amplifier</li> <li>• Short to GND circuit between A/C amplifier and refrigerant pressure switch</li> </ul>
		No	Inspect for stuck closed A/C switch.
5	<ul style="list-style-type: none"> <li>• Verify test results.                             <ul style="list-style-type: none"> <li>— If okay, return to diagnostic index to service any additional symptoms.</li> <li>— If malfunction remains, refer to related Service Bulletins and perform repair or diagnosis.                                     <ul style="list-style-type: none"> <li>• If vehicle is repaired, troubleshooting completed.</li> <li>• If vehicle is not repaired or additional diagnostic information is not available, replace PCM.</li> </ul> </li> </ul> </li> </ul>		

# SYMPTOM TROUBLESHOOTING [ENGINE CONTROL SYSTEM (ZM)]

## NO.25 A/C DOES NOT CUT OFF UNDER WIDE OPEN THROTTLE CONDITIONS [ZM]

A3U010318881W67

<b>25</b>	<b>A/C does not cut off under wide open throttle conditions.</b>
<b>DESCRIPTION</b>	<ul style="list-style-type: none"> <li>• A/C compressor magnetic clutch does not disengage under wide open throttle.</li> </ul>
<b>POSSIBLE CAUSE</b>	<ul style="list-style-type: none"> <li>• TP sensor malfunction</li> <li>• TP sensor misadjustment</li> <li>• TP sensor not securely installed</li> </ul>

### Diagnostic procedure

STEP	INSPECTION		ACTION
1	<ul style="list-style-type: none"> <li>• Does A/C compressor disengage when A/C switch is turned off?</li> </ul>	Yes	Go to next step.
		No	Go to symptom troubleshooting "NO.24 A/C IS ALWAYS ON/A/C COMPRESSOR RUNS CONTINUOUSLY [ZM]".
2	<ul style="list-style-type: none"> <li>• Connect WDS or equivalent to DLC-2.</li> <li>• Turn ignition switch on.</li> <li>• Retrieve any DTC.</li> <li>• Is "DTC" displayed?</li> </ul>	Yes	<b>DTC is displayed:</b> <ul style="list-style-type: none"> <li>• Go to appropriate DTC test.</li> </ul>
		No	<b>No DTC is displayed:</b> <ul style="list-style-type: none"> <li>• Inspect TP sensor for proper adjustment.</li> </ul>
3	<ul style="list-style-type: none"> <li>• Verify test results.                             <ul style="list-style-type: none"> <li>— If okay, return to diagnostic index to service any additional symptoms</li> <li>— If malfunction remains, refer to related Service Bulletins and perform repair or diagnosis.                                     <ul style="list-style-type: none"> <li>• If vehicle is repaired, troubleshooting completed.</li> <li>• If vehicle is not repaired or additional diagnostic information is not available, replace PCM.</li> </ul> </li> </ul> </li> </ul>		

01-03A

## NO.26 EXHAUST SULPHUR SMELL [ZM]

A3U010318881W68

<b>26</b>	<b>Exhaust sulphur smell</b>
<b>DESCRIPTION</b>	<ul style="list-style-type: none"> <li>• Rotten egg smell (sulphur) from exhaust</li> </ul>
<b>POSSIBLE CAUSE</b>	<ul style="list-style-type: none"> <li>• Electrical connectors are disconnected or connected poorly.</li> <li>• Charcoal canister malfunction</li> <li>• Vacuum lines are disconnected or connected improperly.</li> <li>• Improper fuel pressure</li> </ul> <p><b>Warning</b>  <b>The following troubleshooting flowchart contains fuel system diagnosis and repair procedures. Read following warnings before performing fuel system services:</b></p> <ul style="list-style-type: none"> <li>• Fuel vapor is hazardous. It can easily ignite, causing serious injury and damage. Always keep sparks and flames away from fuel.</li> <li>• Fuel line spills and leakage are dangerous. Fuel can ignite and cause serious injuries or death and damage. Fuel can also irritate skin and eyes. To prevent this, always complete "BEFORE REPAIR PROCEDURE" and "AFTER REPAIR PROCEDURE" described in this manual.                      (See 01-14-4 BEFORE REPAIR PROCEDURE.)                      (See 01-14-5 AFTER REPAIR PROCEDURE.)</li> </ul>

### Diagnostic procedure

STEP	INSPECTION		ACTION
1	<ul style="list-style-type: none"> <li>• Are any driveability or exhaust smoke concerns present?</li> </ul>	Yes	Go to appropriate flow chart.
		No	Go to next step.
2	<ul style="list-style-type: none"> <li>• Inspect following:                             <ul style="list-style-type: none"> <li>— Electrical connections</li> <li>— Vacuum lines</li> </ul> </li> <li>• Are all items okay?</li> </ul>	Yes	Go to next step.
		No	Service as necessary. Repeat Step 2.
3	<ul style="list-style-type: none"> <li>• Connect WDS or equivalent to DLC-2.</li> <li>• Turn ignition switch on.</li> <li>• Retrieve any DTC.</li> <li>• Is "DTC" displayed?</li> </ul>	Yes	<b>DTC is displayed:</b> <ul style="list-style-type: none"> <li>• Go to appropriate DTC test.</li> </ul>
		No	<b>No DTC is displayed:</b> <ul style="list-style-type: none"> <li>• Go to next step.</li> </ul>

## SYMPTOM TROUBLESHOOTING [ENGINE CONTROL SYSTEM (ZM)]

STEP	INSPECTION	ACTION	
4	<ul style="list-style-type: none"> <li>• Install fuel pressure gauge between fuel filter and fuel distributor.</li> <li>• Start engine and run it at idle.</li> <li>• Is fuel line pressure correct at idle?</li> </ul> <p><b>Fuel line pressure</b> 210—250 kPa {2.1—2.6 kgf/cm<sup>2</sup>, 30—36 psi}</p>	Yes	Go to next step.
		No	<p><b>Zero or low:</b></p> <ul style="list-style-type: none"> <li>• Inspect fuel pump circuit.</li> <li>• Inspect for open fuel pump relief valve.</li> <li>• Inspect for fuel leakage inside pressure regulator.</li> <li>• Inspect for clogged main fuel line.</li> </ul> <p><b>High:</b></p> <ul style="list-style-type: none"> <li>• Inspect pressure regulator for high pressure cause.</li> <li>• Inspect for clogged fuel return line.</li> </ul>
5	<ul style="list-style-type: none"> <li>• Inspect charcoal canister for fuel saturation.</li> <li>• Is excess amount of liquid fuel present in canister?</li> </ul>	Yes	Replace charcoal canister.
		No	<p>Inspect fuel tank vent system.</p> <ul style="list-style-type: none"> <li>• If fuel tank vent system is okay, since sulfur content can vary in different fuels, suggest trying a different brand.</li> <li>• If fuel tank vent system is not okay, repair or replace malfunctioning parts.</li> </ul>
6	<ul style="list-style-type: none"> <li>• Verify test results.                             <ul style="list-style-type: none"> <li>— If okay, return to diagnostic index to service any additional symptoms</li> <li>— If malfunction remains, refer to related Service Bulletins and perform repair or diagnosis.                                     <ul style="list-style-type: none"> <li>• If vehicle is repaired, troubleshooting completed.</li> <li>• If vehicle is not repaired or additional diagnostic information is not available, replace PCM.</li> </ul> </li> </ul> </li> </ul>		

### NO.27 FUEL REFILL CONCERNS [ZM]

A3U010318881W69

27	Fuel refill concerns
<b>DESCRIPTION</b>	<ul style="list-style-type: none"> <li>• Fuel tank does not fill smoothly.</li> </ul>
<b>POSSIBLE CAUSE</b>	<ul style="list-style-type: none"> <li>• Clogged evaporative emission pipes</li> <li>• Nonreturn valve malfunction</li> <li>• Pressure control valve malfunction</li> <li>• Improper use of fuel nozzle</li> <li>• Inadequate fuel filling speed</li> </ul> <p><b>Warning</b> The following troubleshooting flowchart contains fuel system diagnosis and repair procedures. Read following warnings before performing fuel system services:</p> <ul style="list-style-type: none"> <li>• Fuel vapor is hazardous. It can easily ignite, causing serious injury and damage. Always keep sparks and flames away from fuel.</li> <li>• Fuel line spills and leakage are dangerous. Fuel can ignite and cause serious injuries or death and damage. Fuel can also irritate skin and eyes. To prevent this, always complete "BEFORE REPAIR PROCEDURE" and "AFTER REPAIR PROCEDURE" described in this manual. (See 01-14-4 BEFORE REPAIR PROCEDURE.) (See 01-14-5 AFTER REPAIR PROCEDURE.)</li> </ul>

### Diagnostic procedure

STEP	INSPECTION	ACTION	
1	<ul style="list-style-type: none"> <li>• Retrieve DTCs.</li> <li>• Are there any DTCs displayed?</li> </ul>	Yes	Go to appropriate DTC test.
		No	Go to next step.
2	<ul style="list-style-type: none"> <li>• Remove fuel-filler pipe.</li> <li>• Make sure nonreturn valve is installed properly.</li> <li>• Inspect nonreturn valve operation.</li> <li>• Is nonreturn valve okay?</li> </ul>	Yes	<p>Inspect following:</p> <ul style="list-style-type: none"> <li>• Improper use of fuel nozzle</li> <li>• Inadequate fuel filling speed</li> <li>• Pressure control valve</li> </ul>
		No	<p><b>If nonreturn valve is installed improperly:</b></p> <ul style="list-style-type: none"> <li>• Reinstall nonreturn valve to proper position.</li> </ul> <p><b>If nonreturn valve does not operate properly:</b></p> <ul style="list-style-type: none"> <li>• Replace nonreturn valve.</li> </ul>
3	<ul style="list-style-type: none"> <li>• Verify test results.                             <ul style="list-style-type: none"> <li>— If okay, return to diagnostic index to service any additional symptoms.</li> <li>— If malfunction remains, refer to related Service Bulletins and perform repair or diagnosis.                                     <ul style="list-style-type: none"> <li>• If vehicle is repaired, troubleshooting completed.</li> <li>• If vehicle is not repaired or additional diagnostic information is not available, replace PCM.</li> </ul> </li> </ul> </li> </ul>		

# SYMPTOM TROUBLESHOOTING [ENGINE CONTROL SYSTEM (ZM)]

## NO.28 FUEL FILLING SHUT OFF ISSUES [ZM]

A3U010318881W70

<b>28</b>	<b>Fuel filling shut off issues</b>
<b>DESCRIPTION</b>	<ul style="list-style-type: none"> <li>• Fuel does not shut off properly.</li> </ul>
<b>POSSIBLE CAUSE</b>	<ul style="list-style-type: none"> <li>• Clogged evaporative emission pipes</li> <li>• Nonreturn valve malfunction</li> <li>• Fuel shut-off valve malfunction</li> <li>• Fuel nozzle malfunction</li> <li>• Fuel nozzle is not inserted correctly.</li> </ul> <p><b>Warning</b>  <b>The following troubleshooting flowchart contains fuel system diagnosis and repair procedures. Read following warnings before performing fuel system services:</b></p> <ul style="list-style-type: none"> <li>• Fuel vapor is hazardous. It can easily ignite, causing serious injury and damage. Always keep sparks and flames away from fuel.</li> <li>• Fuel line spills and leakage are dangerous. Fuel can ignite and cause serious injuries or death and damage. Fuel can also irritate skin and eyes. To prevent this, always complete "BEFORE REPAIR PROCEDURE" and "AFTER REPAIR PROCEDURE" described in this manual.                      (See 01-14-4 BEFORE REPAIR PROCEDURE.)                      (See 01-14-5 AFTER REPAIR PROCEDURE.)</li> </ul>

01-03A

### Diagnostic procedure

STEP	INSPECTION		ACTION
1	<ul style="list-style-type: none"> <li>• Retrieve DTCs.</li> <li>• Are there any DTCs displayed?</li> </ul>	Yes	Go to appropriate DTC test.
		No	Go to next step.
2	<ul style="list-style-type: none"> <li>• Remove fuel-filler pipe.</li> <li>• Make sure nonreturn valve is installed properly.</li> <li>• Inspect nonreturn valve operation.</li> <li>• Is nonreturn valve okay?</li> </ul>	Yes	Inspect for following: <ul style="list-style-type: none"> <li>• Improper use of fuel nozzle</li> <li>• Fuel nozzle is not inserted correctly.</li> <li>• Inspect fuel shut-off valve</li> </ul>
		No	<b>If nonreturn valve is installed improperly:</b> <ul style="list-style-type: none"> <li>• Reinstall nonreturn valve to proper position.</li> </ul> <b>If nonreturn valve does not operate properly:</b> <ul style="list-style-type: none"> <li>• Replace nonreturn valve.</li> </ul>
3	<ul style="list-style-type: none"> <li>• Verify test results.                             <ul style="list-style-type: none"> <li>— If okay, return to diagnostic index to service any additional symptoms.</li> <li>— If malfunction remains, refer to related Service Bulletins and perform repair or diagnosis.                                     <ul style="list-style-type: none"> <li>• If vehicle is repaired, troubleshooting completed.</li> <li>• If vehicle is not repaired or additional diagnostic information is not available, replace PCM.</li> </ul> </li> </ul> </li> </ul>		

## NO.29 INTERMITTENT CONCERNS [ZM]

A3U010318881W71

<b>29</b>	<b>Intermittent concerns</b>
<b>DESCRIPTION</b>	<ul style="list-style-type: none"> <li>• Symptom occurs randomly and is difficult to diagnose.</li> </ul>

### Diagnostic procedure

STEP	INSPECTION		ACTION
1	<ul style="list-style-type: none"> <li>• Talk to customer.</li> <li>• Retrieve vehicle service history.</li> <li>• Does vehicle have a number of previous repairs and components replaced for a certain symptom?</li> </ul>	Yes	Go to next step.
		No	Go to Symptom Index.
2	<ul style="list-style-type: none"> <li>• Connect WDS or equivalent to DLC-2.                             <ul style="list-style-type: none"> <li>— If input is switch-type component, turn on manually.</li> </ul> </li> <li>• Turn ignition switch on.</li> <li>• Access PIDs for suspect component.</li> <li>• Lightly tap on suspect component, wiggle and pull each wire/connector at suspect component or PCM.</li> <li>• Are any PID values out of range, or do they suddenly change and go back into range?</li> </ul>	Yes	Inspect each wire for corrosion, bent or loose terminal crimps.
		No	Go to next step.



## SYMPTOM TROUBLESHOOTING [ENGINE CONTROL SYSTEM (ZM)]

STEP	INSPECTION	ACTION	
3	<ul style="list-style-type: none"> <li>• Start engine.</li> <li>• Lightly tap on suspect component, wiggle and pull each wire/connector at suspect component or PCM.</li> <li>• Are any PID values out of range, or do they suddenly change and go back into range?</li> </ul>	Yes	Inspect each wire for corrosion, bent or loose terminal crimps.
		No	Go to next step.
4	<ul style="list-style-type: none"> <li>• Start engine.</li> <li>• Accurately spray water on suspect component wire, component or vacuum line related to possible fault area.</li> <li>• Are any PID values out of range, or suddenly change and go back into range, or was there a noticeable engine misfire/stumble?</li> </ul>	Yes	<p><b>Fault occurred while spraying on component:</b></p> <ul style="list-style-type: none"> <li>• Replace part and verify repair.</li> </ul> <p><b>Fault occurred while spraying wiring:</b></p> <ul style="list-style-type: none"> <li>• Inspect each wire for corrosion, bent or loose terminals and poor wire terminal crimps.</li> </ul> <p><b>Fault occurred while spraying vacuum line:</b></p> <ul style="list-style-type: none"> <li>• Repair vacuum hoses.</li> </ul>
		No	Inspect wire and connector at suspect component for corrosion, bent or loose terminals, poor wire terminal crimps and high tension of wire. Repair as necessary.

### NO.30 CONSTANT VOLTAGE [ZM]

A3U010318881W72

30	Constant voltage
<b>DESCRIPTION</b>	<ul style="list-style-type: none"> <li>• Incorrect constant voltage</li> </ul>
<b>POSSIBLE CAUSE</b>	<ul style="list-style-type: none"> <li>• Constant voltage circuit malfunction</li> </ul> <p style="margin-left: 20px;"><b>Note</b></p> <ul style="list-style-type: none"> <li>• TP sensor, EGR boost sensor and fuel tank pressure sensor use constant voltage.</li> </ul>

### Diagnostic procedure

STEP	INSPECTION	ACTION	
1	<ul style="list-style-type: none"> <li>• Disconnect appropriate sensor connector where constant voltage circuit inspection failed.</li> <li>• Turn ignition switch on.</li> <li>• Measure voltage between following appropriate sensor connector terminals: — Constant voltage terminal — GND terminal</li> <li>• Is constant voltage <b>greater than 6.0 V</b>?</li> </ul>	Yes	Go to Step 13.
		No	Go to next step.
2	<ul style="list-style-type: none"> <li>• Is voltage across battery terminals <b>greater than 10.5 V</b>?</li> </ul>	Yes	Go to next step.
		No	Inspect charging system.
3	<ul style="list-style-type: none"> <li>• Turn ignition switch off.</li> <li>• Leave appropriate sensor connector disconnected.</li> <li>• Measure voltage between battery positive terminal and GND (between PCM and appropriate sensor) circuit at appropriate sensor connector.</li> <li>• Is voltage <b>greater than 10.5 V</b> and <b>within 1.0 V</b> of battery voltage?</li> </ul>	Yes	Go to next step.
		No	Go to Step 8.
4	<p style="margin-left: 20px;"><b>Note</b></p> <ul style="list-style-type: none"> <li>• The purpose of this step is to determine if WDS or equivalent is communicating with PCM.</li> </ul> <ul style="list-style-type: none"> <li>• Turn ignition switch on.</li> <li>• Attempt to access ECT PID.</li> <li>• Can ECT PID be accessed?</li> </ul>	Yes	Go to Step 7.
		No	Go to next step.

## SYMPTOM TROUBLESHOOTING [ENGINE CONTROL SYSTEM (ZM)]

STEP	INSPECTION	ACTION	
5	<ul style="list-style-type: none"> <li>• Turn ignition switch off.</li> <li>• Disconnect TP sensor, EGR boost sensor, fuel tank pressure sensor and PCM connectors.</li> <li>• Turn ignition switch on.</li> <li>• Measure voltage between PCM connector terminals 71/97 and 24/51/76/77/103.</li> <li>• Is voltage <b>greater than 10.5 V</b>?</li> </ul>	Yes	Go to next step.
		No	Repair open circuit between PCM terminal 71/97 and main relay.
6	<ul style="list-style-type: none"> <li>• Leave TP sensor, EGR boost sensor, fuel tank pressure sensor and PCM connectors disconnected.</li> <li>• Measure resistance between PCM connector terminals 90 and 24/51/76/77/103.</li> <li>• Is resistance <b>greater than 10,000 ohms</b>?</li> </ul>	Yes	Inspect for constant voltage at suspect sensor connector again. <ul style="list-style-type: none"> <li>• If malfunction remains, refer to related Service Bulletins and perform repair or diagnosis.                             <ul style="list-style-type: none"> <li>— If vehicle is repaired, troubleshooting completed.</li> <li>— If vehicle is not repaired or additional diagnostic information is not available, replace PCM and repeat Step 6.</li> </ul> </li> </ul>
		No	Repair constant voltage circuit short to GND.
7	<ul style="list-style-type: none"> <li>• Turn ignition switch off.</li> <li>• Leave TP sensor disconnected.</li> <li>• Disconnect PCM connector.</li> <li>• Measure resistance between PCM connector terminal 90 and constant voltage circuit at appropriate sensor connector.</li> <li>• Is resistance <b>less than 5.0 ohms</b>?</li> </ul>	Yes	Inspect for constant voltage at suspect sensor connector again. <ul style="list-style-type: none"> <li>• If malfunction remains, refer to related Service Bulletins and perform repair or diagnosis.                             <ul style="list-style-type: none"> <li>— If vehicle is repaired, troubleshooting completed.</li> <li>— If vehicle is not repaired or additional diagnostic information is not available, replace PCM and repeat Step 7.</li> </ul> </li> </ul>
		No	Repair open constant voltage circuit.
8	<p><b>Note</b></p> <ul style="list-style-type: none"> <li>• The purpose of this step is to determine if WDS or equivalent is communicating with PCM.</li> <li>• Reconnect TP sensor connector.</li> <li>• Turn ignition switch on.</li> <li>• Attempt to access ECT PID.</li> <li>• Can ECT PID be accessed?</li> </ul>	Yes	Go to next step.
		No	Go to Step 11.
9	<ul style="list-style-type: none"> <li>• Are DTCs present for two or more sensors connected to PCM terminal 91?</li> <li>• Sensor connected to PCM terminal 91:                             <ul style="list-style-type: none"> <li>— TP sensor (P0122, P0123, P1122, P1123)</li> <li>— EGR boost sensor (P0106, P0107, P0108)</li> <li>— Fuel tank pressure sensor (P0452, P0453)</li> <li>— ECT sensor (P0117, P0118, P0125)</li> <li>— IAT sensor (P0111, P0112, P0113)</li> <li>— HO2S (front) (P0130, P0134)</li> <li>— HO2S (rear) (P0138, P0140)</li> </ul> </li> </ul>	Yes	Go to next step.
		No	Repair open GND circuit to sensor where constant voltage circuit inspection failed.
10	<ul style="list-style-type: none"> <li>• Turn ignition switch off.</li> <li>• Disconnect WDS or equivalent from DLC-2.</li> <li>• Disconnect PCM connector.</li> <li>• Measure resistance between GND circuit at appropriate sensor connector and PCM connector terminal 91.</li> <li>• Is resistance <b>less than 5.0 ohms</b>?</li> </ul>	Yes	Reconnect sensor connector. Go to appropriate DTC test.
		No	Repair open GND circuit.
11	<ul style="list-style-type: none"> <li>• Turn ignition switch off.</li> <li>• Disconnect PCM connector.</li> <li>• Measure resistance between battery negative terminal and PCM terminals 24/51/76/77/103.</li> <li>• Is each resistance <b>less than 5.0 ohms</b>?</li> </ul>	Yes	Go to next step.
		No	Repair open GND circuit.

01-03A

## SYMPTOM TROUBLESHOOTING [ENGINE CONTROL SYSTEM (ZM)]

STEP	INSPECTION	ACTION	
12	<ul style="list-style-type: none"> <li>• Turn ignition switch off.</li> <li>• Measure resistance between GND circuit at following sensor connector and GND:                             <ul style="list-style-type: none"> <li>— TP sensor</li> <li>— EGR boost sensor</li> <li>— Fuel tank pressure sensor</li> <li>— ECT sensor</li> <li>— IAT sensor</li> <li>— HO2S sensor (front)</li> <li>— HO2S sensor (rear)</li> </ul> </li> <li>• Is each resistance <b>less than 5.0 ohms</b>?</li> </ul>	Yes	GND circuits are okay. Inspect for constant voltage at suspect sensor connector again. <ul style="list-style-type: none"> <li>• If malfunction remains, refer to related Service Bulletins and perform repair or diagnosis.                             <ul style="list-style-type: none"> <li>— If vehicle is repaired, troubleshooting completed.</li> <li>— If vehicle is not repaired or additional diagnostic information is not available, replace PCM and repeat Step 12.</li> </ul> </li> </ul>
		No	Inspect for open GND circuit.
13	<ul style="list-style-type: none"> <li>• Turn ignition switch off.</li> <li>• Disconnect TP sensor, EGR boost sensor, fuel tank pressure sensor and PCM connectors.</li> <li>• Turn ignition switch on.</li> <li>• Measure voltage between constant voltage circuit at TP sensor connector and battery negative terminal.</li> <li>• Is voltage <b>less than 0.5 V</b>?</li> </ul>	Yes	Inspect for constant voltage at suspect sensor connector again. <ul style="list-style-type: none"> <li>• If malfunction remains, refer to related Service Bulletins and perform repair or diagnosis.                             <ul style="list-style-type: none"> <li>— If vehicle is repaired, troubleshooting completed.</li> <li>— If vehicle is not repaired or additional diagnostic information is not available, replace PCM and repeat Step 13.</li> </ul> </li> </ul>
		No	Repair constant voltage circuit short to power in harness.

### NO.31 SPARK PLUG CONDITION [ZM]

A3U010318881W73

31	Spark plug condition
<b>DETECTION CONDITION</b>	<ul style="list-style-type: none"> <li>• Incorrect spark plug condition</li> </ul>
<b>POSSIBLE CAUSE</b>	<p><b>Note</b></p> <ul style="list-style-type: none"> <li>• Inspecting spark plugs condition can determine whether problem is related to a specific cylinder or possibly to all cylinders.</li> </ul> <p><b>Wet/carbon is stuck on specific plug:</b></p> <ul style="list-style-type: none"> <li>• Spark — Weak, not visible</li> <li>• Air/fuel mixture — Excessive fuel injection volume</li> <li>• Compression — No compression, low compression</li> <li>• Faulty spark plug</li> </ul> <p><b>Grayish white with specific plug:</b></p> <ul style="list-style-type: none"> <li>• Air/fuel mixture — Insufficient fuel injection volume</li> <li>• Faulty spark plug</li> </ul> <p><b>Wet/carbon is stuck on all plugs:</b></p> <ul style="list-style-type: none"> <li>• Spark — Weak</li> <li>• Air/fuel mixture — Too rich</li> <li>• Compression — Low compression</li> <li>• Clogging in intake/exhaust system</li> </ul> <p><b>Grayish white with all plugs:</b></p> <ul style="list-style-type: none"> <li>• Air/fuel mixture — Too lean</li> </ul> <p><b>Warning</b></p> <p>The following troubleshooting flow chart contains the fuel system diagnosis and repair procedures. Read the following warnings before performing the fuel system services:</p> <ul style="list-style-type: none"> <li>• Fuel vapor is hazardous. It can easily ignite, causing serious injury and damage. Always keep sparks and flames away from fuel.</li> <li>• Fuel line spills and leakage are dangerous. Fuel can ignite and cause serious injuries or death and damage. Fuel can also irritate skin and eyes. To prevent this, always complete “BEFORE REPAIR PROCEDURE” and “AFTER REPAIR PROCEDURE” described in this manual. (See 01-14-4 BEFORE REPAIR PROCEDURE.) (See 01-14-5 AFTER REPAIR PROCEDURE.)</li> </ul>

# SYMPTOM TROUBLESHOOTING [ENGINE CONTROL SYSTEM (ZM)]

## Diagnostic procedure

STEP	INSPECTION	ACTION	
1	<ul style="list-style-type: none"> <li>• Remove all spark plugs.</li> <li>• Inspect each spark plug.</li> <li>• Is condition of spark plugs okay?</li> </ul>	Yes	Troubleshooting completed.
		No	<p><b>Specific plug is wet or covered with carbon:</b></p> <ul style="list-style-type: none"> <li>• Go to next step.</li> </ul> <p><b>Specific plug looks grayish white:</b></p> <ul style="list-style-type: none"> <li>• Go to Step 7.</li> </ul> <p><b>All plugs are wet or covered with carbon:</b></p> <ul style="list-style-type: none"> <li>• Go to Step 9.</li> </ul> <p><b>All plugs look grayish white:</b></p> <ul style="list-style-type: none"> <li>• Go to Step 15.</li> </ul>
2	<ul style="list-style-type: none"> <li>• Are any of sparks plug wet/covered with carbon from engine oil?</li> </ul>	Yes	Working up and down, inspect all areas related to oil.
		No	Go to next step.
3	<ul style="list-style-type: none"> <li>• Inspect spark plugs for following.                             <ul style="list-style-type: none"> <li>— Cracked insulator</li> <li>— Heating value</li> <li>— Air gap</li> <li>— Worn electrode</li> </ul> </li> <li>• Are spark plugs okay?</li> </ul>	Yes	Go to next step.
		No	Replace spark plug.
4	<ul style="list-style-type: none"> <li>• Inspect compression pressure at suspected faulty cylinder.</li> <li>• Is compression pressure correct? (See 01-10A-8 COMPRESSION INSPECTION [ZM].)</li> </ul>	Yes	Go to next step.
		No	Repair or replace malfunctioning part.
5	<ul style="list-style-type: none"> <li>• Install all spark plugs.</li> <li>• Carry out spark test at suspected faulty cylinder.</li> <li>• Is strong blue spark visible? (Compare with normal cylinder.)</li> </ul>	Yes	Go to next step.
		No	Repair or replace malfunctioning part.
6	<ul style="list-style-type: none"> <li>• Perform fuel line pressure inspection. (See 01-14-28 PRESSURE REGULATOR INSPECTION.)</li> <li>• Is fuel line pressure okay?</li> </ul>	Yes	Inspect fuel injector for following: <ul style="list-style-type: none"> <li>• Open or short in injector</li> <li>• Leakage</li> <li>• Injection volume</li> </ul>
		No	<p><b>Zero or low:</b></p> <ul style="list-style-type: none"> <li>• Inspect fuel pump circuit.</li> <li>• Inspect for open fuel pump relief valve open.</li> <li>• Inspect for fuel leakage inside pressure regulator.</li> <li>• Inspect for clogged main fuel line.</li> </ul> <p><b>High:</b></p> <ul style="list-style-type: none"> <li>• Inspect pressure regulator for high pressure cause.</li> <li>• Inspect for clogged fuel return line.</li> </ul>
7	<ul style="list-style-type: none"> <li>• Inspect spark plugs for following.                             <ul style="list-style-type: none"> <li>— Heating value</li> <li>— Air gap</li> </ul> </li> <li>• Are they okay?</li> </ul>	Yes	Go to next step.
		No	Replace spark plug.
8	<ul style="list-style-type: none"> <li>• Remove suspected fuel injector.</li> <li>• Inspect following:                             <ul style="list-style-type: none"> <li>— Resistance (See 01-14-24 Resistance Inspection.)</li> <li>— Fuel injection volume (See 01-14-26 Volume Test.)</li> </ul> </li> <li>• Are all above items okay?</li> </ul>	Yes	Inspect for open circuit between suspected fuel injector connector terminal and PCM connector following terminals: <ul style="list-style-type: none"> <li>• <b>For #1 cylinder:</b> 75</li> <li>• <b>For #2 cylinder:</b> 101</li> <li>• <b>For #3 cylinder:</b> 74</li> <li>• <b>For #4 cylinder:</b> 100</li> </ul>
		No	Replace fuel injector.
9	<ul style="list-style-type: none"> <li>• Is air cleaner element free of restrictions?</li> </ul>	Yes	Go to next step.
		No	Replace air cleaner element.
10	<ul style="list-style-type: none"> <li>• Carry out spark test.</li> <li>• Is strong blue spark visible at each cylinder?</li> </ul>	Yes	Go to next step.
		No	Repair or replace malfunctioning part.

01-03A

## SYMPTOM TROUBLESHOOTING [ENGINE CONTROL SYSTEM (ZM)]

STEP	INSPECTION	ACTION	
11	<ul style="list-style-type: none"> <li>• Carry out fuel line pressure inspection.</li> <li>• Is fuel line pressure correct?</li> </ul> <p><b>Fuel line pressure</b> 210—250 kPa {2.1—2.6 kgf/cm<sup>2</sup>, 30—36 psi}</p>	Yes	Go to next step.
		No	<p><b>Zero or low:</b></p> <ul style="list-style-type: none"> <li>• Inspect fuel pump circuit.</li> <li>• Inspect for open fuel pump relief valve.</li> <li>• Inspect for fuel leakage inside pressure regulator.</li> <li>• Inspect for clogged main fuel line.</li> </ul> <p><b>High:</b></p> <ul style="list-style-type: none"> <li>• Inspect pressure regulator for high pressure cause.</li> <li>• Inspect for clogged fuel return line.</li> </ul>
12	<ul style="list-style-type: none"> <li>• Inspect following PIDs.                             <ul style="list-style-type: none"> <li>— ECT</li> <li>— O2S11</li> <li>— O2S12</li> <li>— MAF</li> </ul>                             (See 01-40A-7 PCM Inspection Using the SST (WDS or equivalent).)                         </li> <li>• Are PIDs okay?</li> </ul>	Yes	Go to next step.
		No	Repair or replace malfunctioning part.
13	<ul style="list-style-type: none"> <li>• Inspect purge solenoid valve. (When engine can be started)</li> <li>• Is purge solenoid valve okay?</li> </ul>	Yes	Go to next step.
		No	Repair or replace malfunctioning part.
14	<ul style="list-style-type: none"> <li>• Carry out compression inspection.</li> <li>• Is compression correct?</li> </ul>	Yes	Inspect for clogging in exhaust system.
		No	Repair or replace malfunctioning part.
15	<ul style="list-style-type: none"> <li>• When engine cannot be started, inspect intake-air system for air leakage.</li> <li>• When engine can be started, carry out intake manifold vacuum inspection.</li> <li>• Is air sucked in from intake-air system?</li> </ul>	Yes	Repair or replace malfunctioning part.
		No	Go to next step.
16	<ul style="list-style-type: none"> <li>• Carry out fuel line pressure inspection.</li> <li>• Is fuel line pressure correct?</li> </ul> <p><b>Fuel line pressure</b> 210—250 kPa {2.1—2.6 kgf/cm<sup>2</sup>, 30—36 psi}</p>	Yes	Inspect following PIDs. <ul style="list-style-type: none"> <li>• ECT</li> <li>• O2S11</li> <li>• O2S12</li> <li>• MAF</li> </ul> Inspect PCM GND condition.
		No	<p><b>Zero or low:</b></p> <ul style="list-style-type: none"> <li>• Inspect fuel pump circuit.</li> <li>• Inspect for open fuel pump relief valve open.</li> <li>• Inspect for fuel leakage inside pressure regulator.</li> <li>• Inspect for clogged main fuel line.</li> </ul> <p><b>High:</b></p> <ul style="list-style-type: none"> <li>• Inspect pressure regulator for high pressure cause.</li> <li>• Inspect for clogged fuel return line.</li> </ul>
17	<ul style="list-style-type: none"> <li>• Verify test results.                             <ul style="list-style-type: none"> <li>— If okay, return to diagnostic index to service any additional symptoms.</li> <li>— If malfunction remains, inspect related Service Bulletins and perform repair or diagnosis.                                     <ul style="list-style-type: none"> <li>• If vehicle is repaired, troubleshooting is completed.</li> <li>• If vehicle is not repaired or additional diagnostic information is not available, replace PCM.</li> </ul> </li> </ul> </li> </ul>		

# SYMPTOM TROUBLESHOOTING [ENGINE CONTROL SYSTEM (ZM)]

## ENGINE CONTROL SYSTEM OPERATION INSPECTION [ZM]

A3U010318881W74

### Evaporative System Leak Inspection Using Leak Tester

1. Perform the following **SST** (Evaporative Emission System Tester MZ254AT3641) self-test:

#### Note

- If the tester does not work correctly during self-test, refer to the tester operators manual for more detailed self test procedures.

- (1) Verify the gas cylinder valve is closed and the control valve located on the tester is in the TEST position. All tester displays should be off at this time.
- (2) Connect the long hose (part of **SST**) to the tester.
- (3) Connect the manifold assembly (part of **SST**) to the long hose as shown.
- (4) Open the gas cylinder valve and verify the gas cylinder regulator left gauge reads **10 to 12 psi** (preset at factory).
  - If not, refer to the tester operators manual to contact tester manufacturer.
- (5) Press the ON/OFF switch to turn on the **SST** and make sure the left display reads **0.0**.
- (6) Turn the control valve on the tester to the FILL position.
- (7) Verify the left display reading is within **13.9 to 14.0 inches** of water.
  - If not, adjust the pressure using the regulator knob located on the right side of the tester.
- (8) Turn the control valve to TEST position and press the START switch.
- (9) **After the 2-minute** countdown (left display) is completed, the right display shows the total pressure loss for that period. A **0.5 inch** of water loss is acceptable on the self-test.
  - If the loss is **more than 0.5 inch** of water, do one or more self-test. If the failed test repeats, check for leak using the ultrasonic leak detector (part of **SST**).

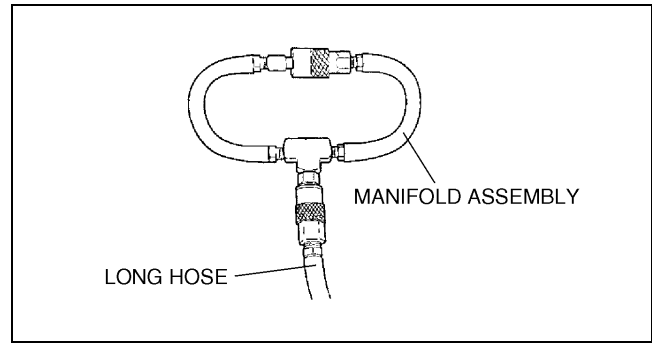

2. Press the RESET switch to set the left display reading to **0.0**.
3. Connect the fuel cap test adapter (part of **SST**) to the manifold assembly and fuel-filler cap from the vehicle.
  - If the fuel-filler cap is not a genuine part, replace it.
4. Connect the threaded test adapter (part of **SST**) to the manifold assembly and fuel-filler neck.
5. Connect the WDS or equivalent to DLC-2.
6. Turn the ignition key to ON (engine OFF).
7. Close the canister drain cut valve (CDCV) using ON BOARD DEVICE CONTROL function (mode 08).

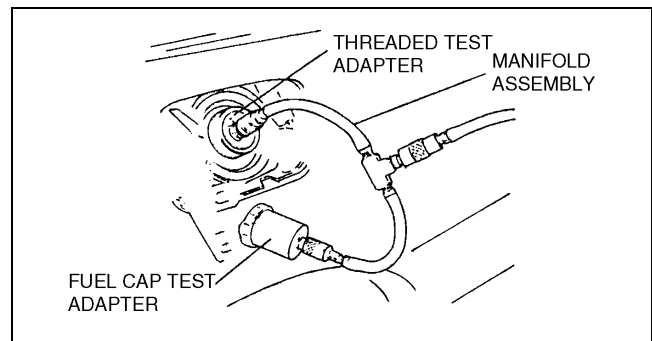

#### Note

- The CDCV is closed for **10 minutes unless** the following any action is done:
  - The engine is started.
  - The ignition key is turned to OFF.
  - The fuel tank pressure sensor signal **exceeds 6.43 kPa {48.3 mmHg, 1.9 inHg}**.

8. Turn the control valve to the FILL position.
9. Wait (**maximum 40 seconds**) until the left display reads **13.5 to 14 inches** of water.
  - If the reading is slightly below, adjust it using the regulator knob.
  - If the reading is far below, the EVAP system has large leak. Check for leak (using the ultrasonic leak detector if necessary) and repair.
10. Turn the control valve to the TEST position and press the START switch.
11. **After the 2-minute** countdown (left display) is completed, check the test result (the failed/passed light on the tester).
  - If the green light turns on, the EVAP system is OK.
  - If the red light turns on, the EVAP system has leakage. Check for leak using the ultrasonic leak detector and repair.
12. Close the gas cylinder valve.
13. Turn the control valve to the FILL position.
14. Press the ON/OFF switch to turn off the tester.

## SYMPTOM TROUBLESHOOTING [ENGINE CONTROL SYSTEM (ZM)]

### Evaporative System Leak Inspection Using Vacuum Pump

#### Whole system inspection

1. Disconnect the vacuum hose between the purge solenoid valve and the catch tank from the purge solenoid valve.
2. Insert hose on the vacuum pump.
3. Connect WDS or equivalent to DLC-2.
4. Turn ignition key to ON (Engine OFF).
5. Close the canister drain cut valve (CDCV) using ON BOARD DEVICE CONTROL function.

#### Note

- The CDCV is closed for **10 minutes unless** the following any action is done:
  - The engine is started.
  - The ignition key is turned to OFF.
  - The fuel tank pressure sensor signal **exceeds 6.43 kPa {48.3 mmHg, 1.9 inHg}**.

6. Apply 1.7 kPa vacuum and monitor FTP output voltage.
7. Verify that the voltage holds at the specified readings for a minimum of 2 minutes.
  - If the voltage does not hold, inspect the fuel tank pressure sensor.
  - If the fuel tank pressure sensor is okay, carry out the “Inspection from charcoal canister to fuel tank”.

#### Inspection from charcoal canister to fuel tank

1. Inspect for loose and wrongly connected hoses between the charcoal canister and the fuel tank. (See 01–16–2 EMISSION SYSTEM LOCATION INDEX.)
2. Disconnect the vacuum hose between the charcoal canister and the fuel tank from the charcoal canister.
3. Insert hose on the vacuum pump.
4. Apply 1.7 kPa vacuum.
5. Verify that the vacuum holds at the specified readings for a minimum of 2 minutes.
  - If the vacuum does not hold, inspect the fuel tank, related vacuum hoses and fuel-filler cap.
  - If the the fuel tank, related vacuum hoses and fuel-filler cap are okay, carry out the “Inspection from charcoal canister to fuel tank”.

#### Inspection from charcoal canister to purge solenoid valve

1. Inspect for loose and wrongly connected hoses between the charcoal canister and the purge solenoid valve. (See 01–16–2 EMISSION SYSTEM LOCATION INDEX.)
2. Disconnect the vacuum hose between the charcoal canister and the catch tank from the charcoal canister.
3. Insert hose on the vacuum pump.
4. Apply **3.3 kPa {25 mmHg, 1.0 inHg}** vacuum. Vacuum should hold at the specified readings for a minimum of 2 minutes.
  - If the vacuum does not hold, inspect the following:
    - Catch tank for plugging, damages and pinhole using vacuum pump
    - Purge solenoid valve (See 01–16–12 PURGE SOLENOID VALVE INSPECTION.)
    - Charcoal canister for damage and pinhole (See 01–16–9 CHARCOAL CANISTER INSPECTION.)
    - CDCV for damage and leakage (See 01–16–10 CANISTER DRAIN CUT VALVE (CDCV) INSPECTION .)
    - Detached, incorrectly installed or cracked hose from charcoal canister to CDCV

#### Main Relay Operation Inspection

1. Verify that the main relay clicks when the ignition switch is turned to on and off.
  - If there is no operation sound, inspect the following:
    - Main relay
    - Harness and connector between ignition switch and main relay

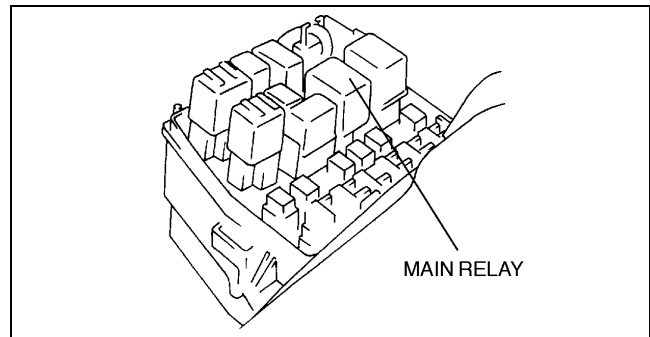

X3U101WCV

## Intake Manifold Vacuum Inspection

1. Verify air intake hoses are installed properly.
2. Start the engine and run it at idle.
3. Measure the intake manifold vacuum using a vacuum gauge.
  - If not as specified, inspect the following:
    - Air suction at throttle body, intake manifold and PCV valve installation points
    - Fuel injector insulator
    - Accelerator cable free play
    - Engine compression (See 01-10A-8 COMPRESSION INSPECTION [ZM].)

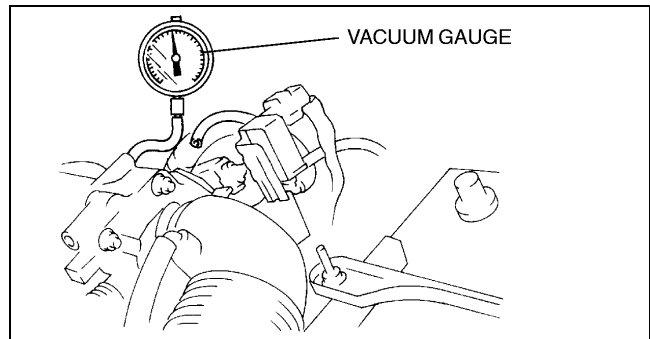

X3U101WCW

### Specification

**More than 60 kPa {450 mmHg, 18 inHg}**

### Note

- Air suction can be located by engine speed change when lubricant is sprayed on the area where suction is occurring.

## Idle Air Control (IAC) Inspection

### Engine coolant temperature compensation inspection

1. Connect the WDS or equivalent to DLC-2.
2. Select the following PIDs.
  - ECT
  - RPM
3. Verify that the engine is in cold condition, then start the engine.
4. Verify that the engine speed decreases as the engine warms up.
  - If the engine speed does not decrease or decreases slowly, carry out the following:
    - ECT sensor inspection
    - IAC valve inspection

### Load compensation inspection

1. Warm up the engine to normal operating temperature and run it at idle.
2. Connect the WDS or equivalent to DLC-2.
3. Select the following PID.
  - RPM
4. Turn the electrical loads on and verify that the engine speed is within the specification.
  - If not as specified, carry out the following:
    - A/C switch inspection
    - P/S pressure switch inspection
    - IAC valve inspection

### Engine speed (rpm)

Load condition	Idle-up speed (rpm)*
No load	650—750 (700±50)
Headlight switch is on.	
P/S on	700—800 (750±50)
A/C on	

\* : Neutral or P position

### Note

- Excludes temporary idle speed drop just after the loads are turned on.



## SYMPTOM TROUBLESHOOTING [ENGINE CONTROL SYSTEM (ZM)]

### Variable Tumble Control System (VTCS) Inspection

1. Connect the WDS or equivalent to the DLC-2.
2. Access ECT PID.
3. Verify ECT PID is **65 °C {149 °F}** or less.
4. Start the engine.
5. Verify that the rod of tumble swirl control actuator is pulled.
  - If the rod is not pulled, inspect the following.
    - VTCS shutter valve actuator
    - VTCS delay valve
    - VTCS chamber
    - Vacuum hose
    - Tumble swirl control solenoid valve
    - Wiring harness and connectors (Main relay — VTCS solenoid valve — PCM terminal 19)
6. Access RPM PID.
7. Inspect the rod operation under the following condition.
  - If the rod operation is not as specified, inspect the following:
    - Tumble swirl control actuator
    - Vacuum delay valve
    - Vacuum chamber
    - Vacuum hose
    - VTCS solenoid valve
    - Wiring harness and connectors (Main relay — VTCS solenoid valve — PCM terminal 19)

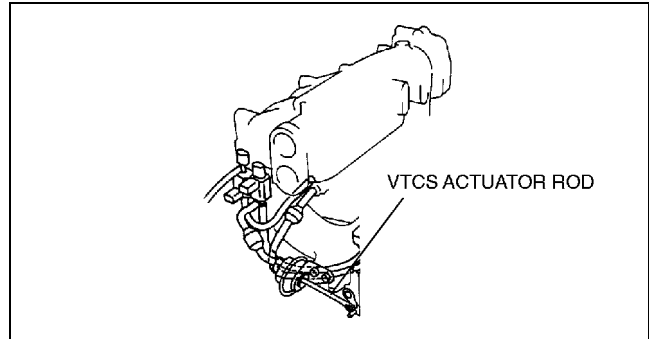

X3U101WEB

### Rod operation

Engine speed (RPM PID) (rpm)	Tumble swirl control actuator
3,000 or less	Operate
3,000 or more	Not operate

# SYMPTOM TROUBLESHOOTING [ENGINE CONTROL SYSTEM (ZM)]

## Pressure Regulator Control Inspection

### Warning

- Fuel line spills and leakage are dangerous. Fuel can ignite and cause serious injuries or death. Fuel can also irritate skin and eyes.
- To prevent this, always complete the “BEFORE REPAIR PROCEDURE”. (See 01-14-4 BEFORE REPAIR PROCEDURE.)

1. Disconnect the negative battery cable.
2. Connect a fuel pressure gauge between the fuel filter and fuel distributor.
3. Connect the negative battery cable.
4. Measure the fuel line pressure under the following conditions.

### Specification

Condition	Fuel pressure (kPa {kgf/cm <sup>2</sup> , psi})		
Idling	210—250 {2.1—2.6, 30—36}		
During 100 sec. of hot start	270—310 {2.7—3.2, 39—45}	210—250 {2.1—2.6, 30—36}	270—310 {2.7—3.2, 39—45}
After 100 sec. of hot start	210—250 {2.1—2.6, 30—36}		
<b>Judgment</b>	Normal	Not Normal (Perform Inspection 1)	Not Normal (Perform Inspection 2)

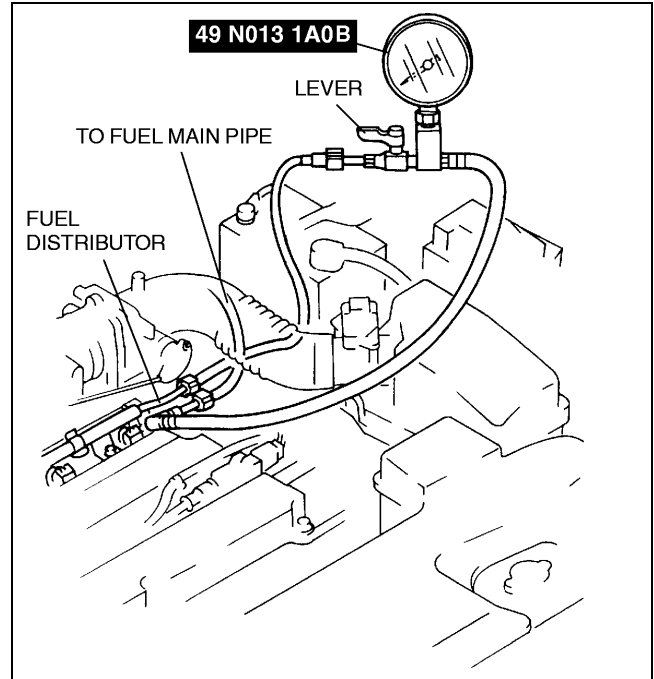

X3U101WD7

### Inspection 1

1. Inspect the following.
  - ECT, IAT, TP PIDs.
  - Pressure regulator.
  - PRC solenoid valve.

### Inspection 2

1. Inspect the following.
  - Loose or damage vacuum hose. (Pressure regulator—PRC solenoid valve—intake manifold)
  - PRC solenoid valve.

01-03A

## SYMPTOM TROUBLESHOOTING [ENGINE CONTROL SYSTEM (ZM)]

### Fuel Injector Operation Inspection

STEP	INSPECTION	ACTION	
1	<ul style="list-style-type: none"> <li>While cranking engine, inspect for fuel injector operation sound at each cylinder using a soundscope.</li> <li>Is operation sound heard?</li> </ul>	Yes	Fuel injector operation is okay.
		No	<b>All cylinders no heard:</b> Go to next step. <b>Some cylinders no heard:</b> Go to Step 3.
2	<ul style="list-style-type: none"> <li>Carry out main relay operation inspection.</li> <li>Is main relay operation normal?</li> </ul>	Yes	Inspect following: Fuel injector power system related wiring harness and connectors PCM connectors Fuel injector GND and related wiring harness and connectors
		No	Repair or replace malfunctioning parts.
3	<ul style="list-style-type: none"> <li>Change fuel injector connector of not operating fuel injector and operating fuel injector.</li> <li>Is operation sound heard?</li> </ul>	Yes	Go to next step.
		No	Replace fuel injector.
4	<ul style="list-style-type: none"> <li>Are wiring harness and connectors of not operating fuel injector okay? (Open or short)</li> </ul>	Yes	Inspect PCM terminal voltage of fuel injector signal.
		No	Repair or replace malfunctioning parts.

### Spark Test

1. Disconnect the fuel pump relay connector.
2. Verify that each high-tension lead and connector is connected property.
3. Inspect the ignition system in the following procedure.

### Warning

- **High voltage in the ignition system can cause strong electrical shock which can result in serious injury. Avoid direct contact to the vehicle body during the following spark test.**

STEP	INSPECTION	ACTION	
1	<ul style="list-style-type: none"> <li>Remove high-tension lead from spark plug.</li> <li>Hold high-tension lead with installed pliers <b>5—10 mm {0.20—0.39 in}</b> from GND.</li> <li>Crank engine and verify there is a strong blue spark. (Inspect each cylinder.)</li> </ul>	Yes	Ignition system is okay.
		No	<b>Some cylinders do not spark:</b> Go to next step. <b>All cylinders do not spark:</b> Go to Step 3.
2	<ul style="list-style-type: none"> <li>Is high-tension lead resistance correct?</li> </ul>	Yes	Inspect for cracks or damage of high-tension lead and ignition coil.
		No	Replace high-tension lead.
3	<ul style="list-style-type: none"> <li>Does PCM or ignition coil connector have poor connection?</li> </ul>	Yes	Repair or replace connector.
		No	Go to next step.
4	<ul style="list-style-type: none"> <li>Is ignition coil winding resistance okay?</li> </ul>	Yes	Go to next step.
		No	Replace ignition coil.
5	<ul style="list-style-type: none"> <li>Are following parts okay? — CKP sensor and crankshaft pulley (also, inspect gap)</li> </ul> <p style="margin-left: 20px;"><b>Specification</b> <b>0.5—1.5 mm {0.020—0.059 in}</b></p> <ul style="list-style-type: none"> <li>— PCM terminal 21/22 voltage</li> </ul> <p style="margin-left: 20px;"><b>Specification</b> <b>Approx. 1.5 V</b></p>	Yes	Inspect for open or short in wiring harness and connector of CKP sensor.
		No	Repair or replace malfunctioning parts.

# **01-03B SYMPTOM TROUBLESHOOTING [ENGINE CONTROL SYSTEM (FS)]**

**CONTROL SYSTEM DEVICE AND CONTROL**

**RELATIONSHIP CHART [FS]** ..... 01-03B-2  
 Engine Control System ..... 01-03B-2  
 Monitoring System ..... 01-03B-3  
**FOREWORD [FS]** ..... 01-03B-4  
**INTERMITTENT CONCERN**  
**TROUBLESHOOTING [FS]** ..... 01-03B-4  
 Vibration Method ..... 01-03B-4  
 Water Sprinkling Method ..... 01-03B-6  
**SYMPTOM DIAGNOSTIC INDEX [FS]** .. 01-03B-7  
**SYMPTOM QUICK DIAGNOSIS CHART**  
**[FS]** ..... 01-03B-9  
**NO.1 MELTING OF MAIN OR OTHER**  
**FUSES [FS]** ..... 01-03B-13  
**NO.2 MIL ILLUMINATES [FS]** ..... 01-03B-14  
**NO.3 WILL NOT CRANK [FS]** ..... 01-03B-14  
**NO.4 HARD START/LONG CRANK/ERRATIC**  
**START/ERRATIC CRANK [FS]** ..... 01-03B-15  
**NO.5 ENGINE STALLS-AFTER START/AT IDLE**  
**[FS]** ..... 01-03B-17  
**NO.6 CRANKS NORMALLY BUT WILL NOT START**  
**[FS]** ..... 01-03B-20  
**NO.7 SLOW RETURN TO IDLE [FS]** ... 01-03B-22  
**NO.8 ENGINE RUNS ROUGH/ROLLING IDLE**  
**[FS]** ..... 01-03B-23  
**NO.9 FAST IDLE/RUNS ON [FS]** ..... 01-03B-26  
**NO.10 LOW IDLE/STALLS DURING**  
**DECELERATION [FS]** ..... 01-03B-26  
**NO.11 ENGINE STALLS/QUITS, ENGINE RUNS**  
**ROUGH, MISSES, BUCK/JERK, HESITATION/**  
**STUMBLE, SURGES [FS]** ..... 01-03B-28  
**NO.12 LACK/LOSS OF POWER-ACCELERATION/**  
**CRUISE [FS]** ..... 01-03B-31  
**NO.13 KNOCKING/PINGING-ACCELERATION/**  
**CRUISE [FS]** ..... 01-03B-33  
**NO.14 POOR FUEL ECONOMY [FS]** ... 01-03B-34  
**NO.15 EMISSION COMPLIANCE [FS]** .. 01-03B-36  
**NO.16 HIGH OIL CONSUMPTION/LEAKAGE**  
**[FS]** ..... 01-03B-37  
**NO.17 COOLING SYSTEM**  
**CONCERNS-OVERHEATING [FS]**.... 01-03B-38

**NO.18 COOLING SYSTEM CONCERNS-RUNS**

**COLD [FS]** .....01-03B-40  
**NO.19 EXHAUST SMOKE [FS]** .....01-03B-41  
**NO.20 FUEL ODOR (IN ENGINE COMPARTMENT)**  
**[FS]** .....01-03B-42  
**NO.21 ENGINE NOISE [FS]**.....01-03B-43  
**NO.22 VIBRATION CONCERNS (ENGINE)**  
**[FS]** .....01-03B-44  
**NO.23 A/C DOES NOT WORK SUFFICIENTLY**  
**[FS]** .....01-03B-44  
**NO.24 A/C IS ALWAYS ON OR A/C COMPRESSOR**  
**RUNS CONTINUOUSLY [FS]** .....01-03B-45  
**NO.25 A/C IS NOT CUT OFF UNDER WIDE OPEN**  
**THROTTLE CONDITIONS [FS]** .....01-03B-46  
**NO.26 EXHAUST SULPHUR SMELL**  
**[FS]** .....01-03B-46  
**NO.27 FUEL REFILL CONCERNS**  
**[FS]** .....01-03B-47  
**NO.28 FUEL FILLING SHUT OFF ISSUES**  
**[FS]** .....01-03B-48  
**NO.29 INTERMITTENT CONCERNS**  
**[FS]** .....01-03B-48  
**NO.30 REFERENCE VOLTAGE [FS]** ...01-03B-49  
**NO.31 SPARK PLUG CONDITION**  
**[FS]** .....01-03B-51  
**ENGINE CONTROL SYSTEM OPERATION**  
**INSPECTION [FS]** .....01-03B-54  
 Evaporative System Leak Inspection Using Leak  
 Tester .....01-03B-54  
 Evaporative System Leak Inspection Using Vacuum  
 Pump .....01-03B-55  
 Main Relay Operation Inspection .....01-03B-55  
 Intake Manifold Vacuum Inspection ...01-03B-56  
 Idle Air Control (IAC) Inspection .....01-03B-56  
 VICS Operation Inspection .....01-03B-57  
 Variable Tumble Control System (VTCS) Inspection  
 .....01-03B-57  
 Pressure Regulator Control Inspection .01-03B-58  
 Fuel Injector Operation Inspection ...01-03B-59  
 Spark Test .....01-03B-59

**01-03B**

# SYMPTOM TROUBLESHOOTING [ENGINE CONTROL SYSTEM (FS)]

## CONTROL SYSTEM DEVICE AND CONTROL RELATIONSHIP CHART [FS]

A3U010318881W01

### Engine Control System

Component	Idle air control (IAC)	Fuel injection control	Pressure regulator control (PRC)	Electronic spark advance (ESA) control	Fuel pump control	HO2S heater (front) control	HO2S heater (rear) control	Electric fan control	Purge control	EGR control	VTCS	A/C cut-out control	Generator control
<b>Input</b>													
Brake switch		x		x									
Refrigerant pressure switch, A/C switch, blower fan switch and A/C amplifier	x	x		x				x				x	
PSP switch	x	x		x								x	
DLC in engine compartment (TEN)	x	x	x	x				x					
Neutral switch (MTX)	x	x	x	x									
Clutch switch (MTX)	x	x	x	x									
TR switch (ATX)	x	x	x	x									
CKP sensor	x	x	x	x	x	x	x	x	x	x	x	x	x
CMP sensor	x	x		x									
VSS	x	x		x						x			x
MAF sensor	x	x		x		x	x		x	x			
ECT sensor	x	x	x	x		x	x	x	x	x		x	x
IAT sensor	x	x	x	x		x			x	x			x
TP sensor	x	x	x	x		x		x	x	x		x	x
EGR boost sensor	x	x							x			x	
Battery positive voltage		x		x		x			x				x
Generator	x			x									x
HO2S (front)		x							x				
HO2S (rear)													
<b>Output</b>													
IAC valve	x												
A/C relay												x	
Cooling fan relay								x					
Condenser fan relay								x					
Fuel pump relay					x								
PRC solenoid valve			x										
Purge solenoid valve									x				
VTCS solenoid valve											x		
EGR valve										x			
HO2S heater						x	x						
Ignition coils				x									
Fuel injectors		x											
Generator (field coil)													x
Generator warning light													x

# SYMPTOM TROUBLESHOOTING [ENGINE CONTROL SYSTEM (FS)]

## Monitoring System

x :Applied

Component	Catalyst monitor	Misfire monitor	Evaporative system monitor	Fuel system monitor	Oxygen sensor monitor	Oxygen sensor heater monitor	EGR system monitor
<b>Input</b>							
Brake switch							
Refrigerant pressure switch, A/C switch, blower fan and A/C amplifier		x		x			x
PSP switch		x		x			x
CKP sensor	x	x	x	x	x	x	x
CMP sensor	x	x	x	x	x	x	x
VSS	x	x	x	x	x		x
MAF sensor	x	x	x	x	x	x	x
ECT sensor	x	x	x	x	x	x	x
IAT sensor	x	x	x	x	x		x
TP sensor	x	x	x	x	x		x
EGR boost sensor							x
Fuel level sensor			x				
Fuel gauge sender unit			x				
Rear HO2S	x				x	x	
Front HO2S	x			x	x	x	
<b>Output</b>							
DLC-2 in passenger compartment (Terminal KLN)	x	x	x	x	x	x	x
MIL	x	x	x	x	x	x	x
Purge solenoid valve			x	x	x		
EGR valve							x
EGR boost sensor solenoid valve							x
Canister drain cut valve			x				
Fuel injectors				x			

01-03B

Y3U103WA6

# SYMPTOM TROUBLESHOOTING [ENGINE CONTROL SYSTEM (FS)]

## FOREWORD [FS]

A3U010318881W02

- When the customer reports a vehicle malfunction, check the malfunction indicator light (MIL) and diagnostic trouble code (DTC), then diagnose the malfunction according to following flowchart.
  - If the DTC exists, diagnose the applicable DTC inspection. (See 01–02B–15 DTC TABLE [FS].)
  - If the DTC does not exist and the MIL does not illuminate or flash, diagnose the applicable symptom troubleshooting. (See 01–03B–7 SYMPTOM DIAGNOSTIC INDEX [FS].)

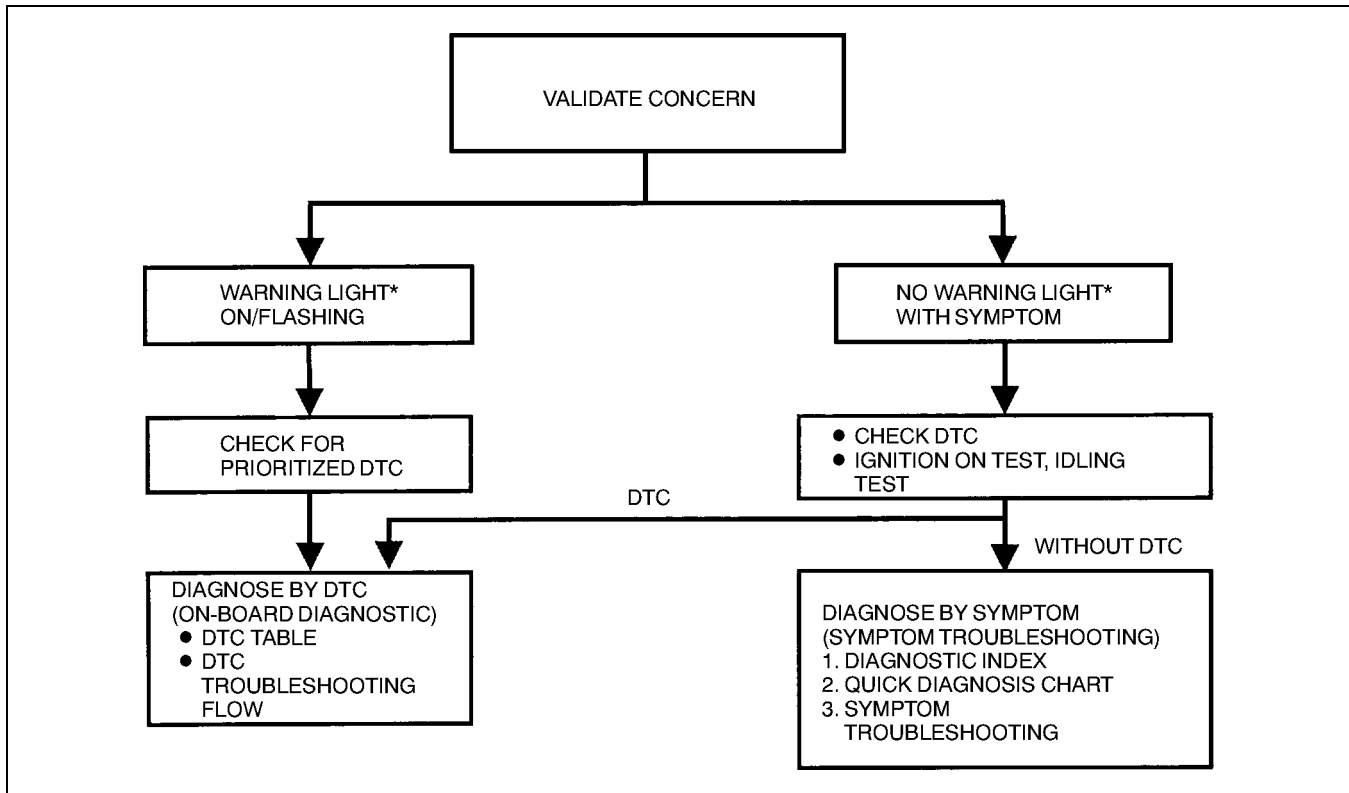

YMU102WBX

\* : Malfunction Indicator Light (MIL), Generator Warning Light, Security Light

## INTERMITTENT CONCERN TROUBLESHOOTING [FS]

A3U010318881W03

### Vibration Method

- If malfunction occurs or becomes worse while driving on a rough road or when engine is vibrating, perform the steps below.

#### Note

- There are several reasons vehicle or engine vibration could cause an electrical malfunction. Some of the things to check for are:
  - Connectors not fully seated.
  - Wire harnesses not having full play.
  - Wires laying across brackets or moving parts.
  - Wires routed too close to hot parts.
- An improperly routed, improperly clamped, or loose harness can cause wiring to become pinched between parts.
- The connector joints, points of vibration, and places where wire harnesses pass through the fire wall, body panels, etc. are the major areas to be checked.

## SYMPTOM TROUBLESHOOTING [ENGINE CONTROL SYSTEM (FS)]

### Inspection Method for Switch Connectors or Wires

1. Connect WDS or equivalent to DLC-2.
2. Turn ignition key to ON (Engine OFF).

#### Note

- If engine starts and runs, perform the following steps at idle.
3. Access PIDs for the switch you are inspecting.
  4. Turn switch on manually.
  5. Shake each connector or wire harness a bit vertically and horizontally while monitoring the PID.
    - If PID value is unstable, check for poor connection.

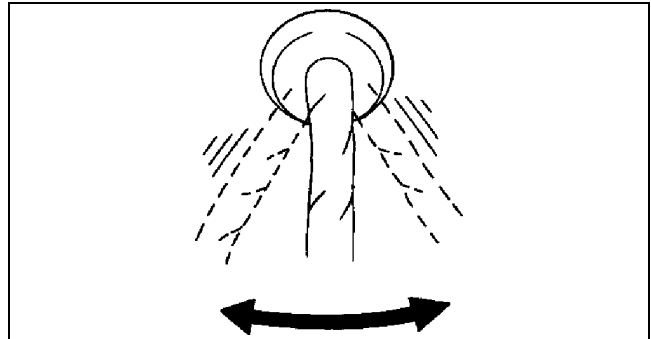

Y3U103WN3

01-03B

### Inspection Method for Sensor Connectors or Wires

1. Connect WDS or equivalent to DLC-2.
2. Turn ignition key to ON (Engine OFF).

#### Note

- If engine starts and runs, perform the following steps at idle.
3. Access PIDs for the switch you are inspecting.
  4. Shake each connector or wire harness a bit vertically and horizontally while monitoring the PID.
    - If PID value is unstable, check for poor connection.

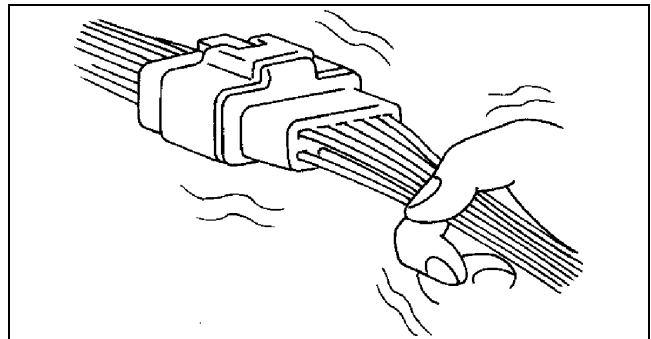

Y3U103WN4

### Inspection Method for Sensors

1. Connect WDS or equivalent to DLC-2.
2. Turn ignition key to ON (Engine OFF).

#### Note

- If engine starts and runs, perform the following steps at idle.
3. Access PIDs for the switch you are inspecting.
  4. Vibrate the sensor slightly with your finger.
    - If PID value is unstable or malfunction occurs, check for poor connection and/or poorly mounted sensor.



## SYMPTOM TROUBLESHOOTING [ENGINE CONTROL SYSTEM (FS)]

### Inspection Method for Actuators or Relays

1. Connect WDS or equivalent to DLC-2.
2. Turn ignition key to ON (Engine OFF).

#### Note

- If engine starts and runs, perform the following steps at idle.

3. Prepare the SIMULATION TEST for actuators or relays that you are inspecting.
4. Vibrate the actuator or relay with your finger for 3 seconds after SIMULATION TEST is activated.
  - If variable click sound is heard, check for poor connection and/or poorly mounted actuator or relay.

#### Note

- Vibrating relays too strongly may result in open relays.

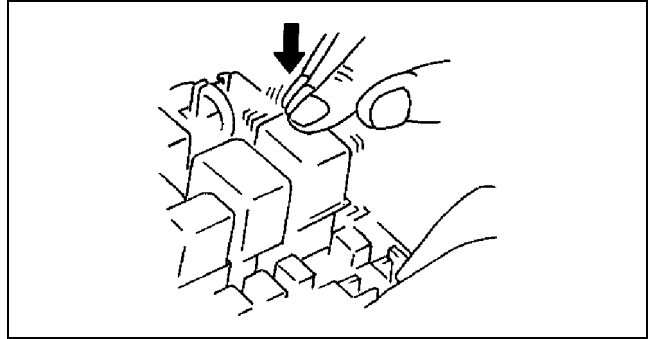

Y3U103WN5

### Water Sprinkling Method

If malfunction occurs only during high humidity or rainy/snowy weather, perform the following steps.

#### Caution

- Indirectly change the temperature and humidity by spraying water onto the front of the radiator.
- If a vehicle is subject to water leakage, the leakage may damage the control module. When testing a vehicle with a water leakage problem, special caution must be used.

1. Connect WDS or equivalent to DLC-2 if you are inspecting sensors or switches.
2. Turn ignition key to ON (Engine OFF).

#### Note

- If engine starts and runs, perform the following steps at idle.

3. Access PIDs for sensor or switch if you are inspecting sensors or switches.
4. If you are inspecting the switch, turn it on manually.
5. Spray water onto the vehicle or run it through a car wash.
  - If PID value is unstable or malfunction occurs, repair or replace part as necessary.

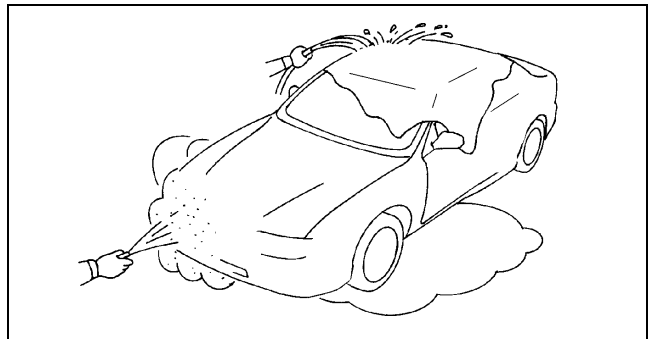

Y3U103WTJ

# SYMPTOM TROUBLESHOOTING [ENGINE CONTROL SYSTEM (FS)]

## SYMPTOM DIAGNOSTIC INDEX [FS]

A3U010318881W04

No.	TROUBLESHOOTING ITEM		DESCRIPTION	PAGE
1	Melting of main or other fuses		—	(See 01-03B-13 NO.1 MELTING OF MAIN OR OTHER FUSES [FS])
2	MIL illuminates		MIL is illuminated incorrectly.	(See 01-03B-14 NO.2 MIL ILLUMINATES [FS])
3	Will not crank		Starter does not work.	(See 01-03B-14 NO.3 WILL NOT CRANK [FS])
4	Hard start/long crank/erratic start/erratic crank		Starter cranks engine at normal speed but engine requires excessive cranking time before starting. Battery is in normal condition.	(See 01-03B-15 NO.4 HARD START/LONG CRANK/ERRATIC START/ERRATIC CRANK [FS])
5	Engine stalls	After start/at idle	Engine stops unexpectedly at idle and/or after start.	(See 01-03B-17 NO.5 ENGINE STALLS-AFTER START/AT IDLE [FS])
6	Crank normally but will not start		Starter cranks engine at normal speed but engine will not run.	(See 01-03B-20 NO.6 CRANKS NORMALLY BUT WILL NOT START [FS])
7	Slow return to idle		Engine takes more time than normal to return to idle speed.	(See 01-03B-22 NO.7 SLOW RETURN TO IDLE [FS])
8	Engine runs rough/rolling idle		Engine speed fluctuates between specified idle speed and lower speed and engine shakes excessively.	(See 01-03B-23 NO.8 ENGINE RUNS ROUGH/ROLLING IDLE [FS])
9	Fast idle/runs on		Engine speed continues at fast idle after warm-up. Engine runs after ignition key is turned to OFF.	(See 01-03B-26 NO.9 FAST IDLE/RUNS ON [FS])
10	Low idle/stalls during deceleration		Engine stops unexpectedly at beginning of deceleration or recovery from deceleration.	(See 01-03B-26 NO.10 LOW IDLE/STALLS DURING DECELERATION [FS])
11	Engine stalls/quits	Acceleration/cruise	Engine stops unexpectedly at beginning of acceleration or during acceleration. Engine stops unexpectedly while cruising.	(See 01-03B-28 NO.11 ENGINE STALLS/QUITS, ENGINE RUNS ROUGH, MISSES, BUCK/JERK, HESITATION/STUMBLE, SURGES [FS])
	Engine runs rough	Acceleration/cruise	Engine speed fluctuates during acceleration or cruising.	
	Misses	Acceleration/cruise	Engine misses during acceleration or cruising.	
	Buck/jerk	Acceleration/cruise/deceleration	Vehicle bucks/jerks during acceleration, cruising, or deceleration.	
	Hesitation/stumble	Acceleration	Momentary pause at beginning of acceleration, or during acceleration	
	Surges	Acceleration/cruise	Momentary minor irregularity in engine output	
12	Lack/loss of power	Acceleration/cruise	Performance is poor under load (e.g. power down when climbing hills).	(See 01-03B-31 NO.12 LACK/LOSS OF POWER-ACCELERATION/CRUISE [FS])
13	Knocking/pinging	Acceleration/cruise	Sound is produced when air/fuel mixture is ignited by something other than spark plug (e.g. hot spot in combustion chamber).	(See 01-03B-33 NO.13 KNOCKING/PINGING-ACCELERATION/CRUISE [FS])
14	Poor fuel economy		Fuel economy is unsatisfactory.	(See 01-03B-34 NO.14 POOR FUEL ECONOMY [FS])
15	Emission compliance		Fails emissions test	(See 01-03B-36 NO.15 EMISSION COMPLIANCE [FS])
16	High oil consumption/leakage		Oil consumption is excessive.	(See 01-03B-37 NO.16 HIGH OIL CONSUMPTION/LEAKAGE [FS])

01-03B

## SYMPTOM TROUBLESHOOTING [ENGINE CONTROL SYSTEM (FS)]

No.	TROUBLESHOOTING ITEM		DESCRIPTION	PAGE
17	Cooling system concerns	Overheating	Engine runs at higher than normal temperature/overheats.	(See 01-03B-38 NO.17 COOLING SYSTEM CONCERNS-OVERHEATING [FS])
18	Cooling system concerns	Runs cold	Engine does not reach normal operating temperature.	(See 01-03B-40 NO.18 COOLING SYSTEM CONCERNS-RUNS COLD [FS])
19	Exhaust smoke		Blue, black, or white smoke from exhaust system	(See 01-03B-41 NO.19 EXHAUST SMOKE [FS])
20	Fuel odor (in engine compartment)		Gasoline fuel smell or visible leakage	(See 01-03B-42 NO.20 FUEL ODOR (IN ENGINE COMPARTMENT) [FS])
21	Engine noise		Engine noise from under hood	(See 01-03B-43 NO.21 ENGINE NOISE [FS])
22	Vibration concerns (engine)		Vibration from under hood or driveline	(See 01-03B-44 NO.22 VIBRATION CONCERNS (ENGINE) [FS])
23	A/C does not work sufficiently.		A/C compressor magnetic clutch does not engage when A/C is turned on.	(See 01-03B-44 NO.23 A/C DOES NOT WORK SUFFICIENTLY [FS])
24	A/C is always ON or A/C compressor runs continuously.		A/C compressor magnetic clutch does not disengage.	(See 01-03B-45 NO.24 A/C IS ALWAYS ON OR A/C COMPRESSOR RUNS CONTINUOUSLY [FS])
25	A/C does not cut off under wide open throttle conditions		A/C compressor magnetic clutch does not disengage under wide open throttle.	(See 01-03B-46 NO.25 A/C IS NOT CUT OFF UNDER WIDE OPEN THROTTLE CONDITIONS [FS])
26	Exhaust sulphur smell		Rotten egg smell (sulphur) from exhaust	(See 01-03B-46 NO.26 EXHAUST SULPHUR SMELL [FS])
27	Fuel refill concerns		Fuel tank does not fill smoothly.	(See 01-03B-47 NO.27 FUEL REFILL CONCERNS [FS])
28	Fuel filling shut off issues		Fuel does not shut off properly.	(See 01-03B-48 NO.28 FUEL FILLING SHUT OFF ISSUES [FS])
29	Intermittent concerns		Symptom occurs randomly and is difficult to diagnose.	(See 01-03B-48 NO.29 INTERMITTENT CONCERNS [FS])
30	Reference voltage		Incorrect reference voltage	(See 01-03B-49 NO.30 REFERENCE VOLTAGE [FS])
31	Spark plug condition		Incorrect spark plug condition	(See 01-03B-51 NO.31 SPARK PLUG CONDITION [FS])
32	ATX concerns	Upshift/downshift/engagement	ATX concerns not related to engine performance	(See 05-03-7 AUTOMATIC TRANSAXLE SYMPTOM TROUBLESHOOTING ITEM TABLE)

# SYMPTOM TROUBLESHOOTING [ENGINE CONTROL SYSTEM (FS)]

## SYMPTOM QUICK DIAGNOSIS CHART [FS]

A3U010318881W05

× : Applied

Troubleshooting item		Possible factor																					
		Starter motor malfunction(Mechanical or electrical)	Starter circuit including ignition key open	Improper engine oil level	Low or dead battery	Charging system malfunction	Improper engine compression	Improper valve timing	Hydrolocked engine	Improper engine oil viscosity	Improper dipstick	Base engine malfunction	Drive plate or flywheel is seized.	Improper tension or damages drive belts	Improper engine coolant level	Water and anti-freeze mixture is improper.	Cooling system malfunction (Radiator,hoses,overflow system,thermostat,etc.)	Cooling fan system malfunction	Engine or transaxle mounts are improperly installed.	Cooling fan or condenser fan seat is improper.	Accelerator cable free play misadjustment	Fuel quality	
1	Melting of main or other fuses																						
2	MIL illuminates.																						
3	Will not crank	×	×		×	×				×				×									
4	Hard start/long crank/erratic start/erratic crank																						×
5	Engine stalls.      After start/at idle																						×
6	Cranks normally but will not start																						×
7	Slow return to idle																						
8	Engine runs rough/rolling idle																						×
9	Fast idle/runs on																						
10	Low idle/stalls during deceleration																						
11	Engine stalls/quits.      Acceleration/cruise																						×
	Engine runs rough.      Acceleration/cruise																						×
	Misses      Acceleration/cruise																						×
	Buck/jerk      Acceleration/cruise/deceleration																						×
	Hesitation/stumble      Acceleration																						×
	Surges      Acceleration/cruise																						×
12	Lack/loss of power      Acceleration/cruise																						×
13	Knocking/pinging      Acceleration/cruise																						
14	Poor fuel economy																						
15	Emissions compliance																						
16	High oil consumption/leakage																						
17	Cooling system concerns      Overheating																						
18	Cooling system concerns      Runs cold																						
19	Exhaust smoke																						
20	Fuel odor (in engine compartment)																						
21	Engine noise																						
22	Vibration concerns (engine)																						
23	A/C does not work sufficiently.																						
24	A/C is always on or A/C compressor runs continuously.																						
25	A/C does not cut off under wide open throttle conditions.																						
26	Exhaust sulphur smell																						
27	Fuel refill concerns																						
28	Fuel filling shut off issues																						
29	Intermittent concerns																						
30	Constant voltage																						
31	Spark plug condition																						
32	Automatic transaxle concerns      Upshift/downshift/engagement																						

See 05-03 AUTOMATIC TRANSAXLE SYMPTOM TROUBLESHOOTING

Y3U103WN7

01-03B

# SYMPTOM TROUBLESHOOTING [ENGINE CONTROL SYSTEM (FS)]

Troubleshooting item		Possible factor																			
		Engine overheating	Air cleaner element clogging or restriction	Air leakage from intake-air system (Loose, tubes, cracks breakage)	IAC valve improper operation	Throttle body malfunction	VICS malfunction	Tumble swirl control system malfunction	Vacuum leakage (Vacuum hose damage, misrouting)	Ignition coil malfunction (e.g. open, short or cracks)	Initial ignition timing misadjustment (CKP & crankshaft pulley misadjustment)	Spark plug malfunction	High-tension leads malfunction (Cracks, open, low resistance)	CKP sensor is damaged (e.g. open or short circuits).	Crankshaft pulley is damaged.	Improper gap between CKP sensor and crankshaft pulley	Fuel pump malfunction (Mechanical or electrical)	Pressure regulator malfunction	Fuel hoses restriction or clogging		
1	Melting of main or other fuses																				
2	MIL illuminates.																				
3	Will not crank																				
4	Hard start/long crank/erratic start/erratic crank		x	x				x			x	x	x	x	x	x	x	x	x		
5	Engine stalls. After start/at idle	x	x	x	x			x	x	x	x	x	x	x	x	x	x	x	x		
6	Cranks normally but will not start	x		x	x			x	x	x	x	x	x	x	x	x	x	x	x		
7	Slow return to idle						x														
8	Engine runs rough/rolling idle	x		x	x	x		x		x	x	x	x	x	x	x	x	x	x		
9	Fast idle/runs on																				
10	Low idle/stalls during deceleration			x	x																
11	Engine stalls/quits.	Acceleration/cruise	x	x	x		x		x		x		x	x	x	x	x	x	x		
	Engine runs rough.	Acceleration/cruise	x	x	x		x		x		x		x	x	x	x	x	x	x		
	Misses	Acceleration/cruise	x	x	x		x		x		x		x	x	x	x	x	x	x		
	Buck/jerk	Acceleration/cruise/deceleration	x	x	x		x		x		x		x	x	x	x	x	x	x		
	Hesitation/stumble	Acceleration	x	x	x		x		x		x		x	x	x	x	x	x	x		
	Surges	Acceleration/cruise	x	x	x		x		x		x		x	x	x	x	x	x	x		
12	Lack/loss of power	Acceleration/cruise	x	x	x		x	x	x		x		x	x	x	x	x	x	x		
13	Knocking/pinging	Acceleration/cruise	x															x	x		
14	Poor fuel economy		x					x	x			x	x					x	x	x	
15	Emissions compliance		x	x		x						x	x					x	x	x	
16	High oil consumption/leakage																				
17	Cooling system concerns	Overheating																			
18	Cooling system concerns	Runs cold																			
19	Exhaust smoke		x										x	x				x	x	x	
20	Fuel odor (in engine compartment)																		x		
21	Engine noise			x					x												
22	Vibration concerns (engine)																				
23	A/C does not work sufficiently.																				
24	A/C is always on or A/C compressor runs continuously.																				
25	A/C does not cut off under wide open throttle conditions.																				
26	Exhaust sulphur smell																				
27	Fuel refill concerns																				
28	Fuel filling shut off issues																				
29	Intermittent concerns					x		x	x	x		x	x	x				x	x		
30	Constant voltage																				
31	Spark plug condition		x										x						x	x	x
32	Automatic transaxle concerns	Upshift/downshift/engagement																			

See 05-03 AUTOMATIC TRANSAXLE SYMPTOM TROUBLESHOOTING

# SYMPTOM TROUBLESHOOTING [ENGINE CONTROL SYSTEM (FS)]

× : Applied

01-03B

Troubleshooting Item		Possible factor																	
		Injectors malfunction (Leakage or clogging, inoperative)	Fuel leakage from fuel system (Including Insulator, injector O-ring)	Fuel filters restriction or clogging	PRC solenoid valve improper operation	CRP sensor is damaged (e.g. open or short circuit).	Camshaft is damaged.	Improper air/fuel mixture ratio control	Exhaust system restriction or clogging	Catalytic converter malfunction	EGR system malfunction	Evaporative emission control system malfunction	PCV valve malfunction	V-reference supply circuit malfunction	Main relay malfunction (Mechanical or electrical)	ECT sensor malfunction	TR switch misadjustment (ATX)	P/N position switch in TR switch is open, (ATX)	Brake switch and related circuit malfunction
1	Melting main or other fuses																		
2	MIL illuminates.																		
3	Will not crank																	x	
4	Hard start/long crank/erratic start/erratic crank			x	x			x	x		x	x	x						
5	Engine stalls.																		
	After start/at idle	x	x					x	x		x	x	x		x				
6	Cranks normally but will not start	x	x					x	x		x	x	x	x	x				
7	Slow return to idle															x			
8	Engine runs rough/rolling idle	x		x		x	x	x	x		x	x	x						
9	Fast idle/runs on															x			
10	Low idle/stalls during deceleration							x			x							x	
11	Engine stalls/quits.	x		x		x	x	x	x		x	x	x	x	x				
	Acceleration/cruise																		
	Engine runs rough.	x		x		x	x	x	x		x	x	x	x	x				
	Acceleration/cruise																		
	Misses	x		x		x	x	x	x		x	x	x	x	x				
	Acceleration/cruise																		
Buck/jerk	x		x		x	x	x	x		x	x	x	x	x					
Acceleration/cruise/deceleration																			
Hesitation/stumble	x		x		x	x	x	x		x	x	x	x	x					
Acceleration																			
Surges	x		x		x	x	x	x		x	x	x	x	x					
Acceleration/cruise																			
12	Lack/loss of power	x				x	x		x		x	x	x						
Acceleration/cruise																			
13	Knocking/pinging																		
Acceleration/cruise																			
14	Poor fuel economy			x	x	x	x		x				x						
15	Emissions compliance			x		x	x	x	x	x	x	x							
16	High oil consumption/leakage												x						
17	Cooling system concerns																		
Overheating																			
18	Cooling system concerns																		
Runs cold																			
19	Exhaust smoke	x			x								x						
20	Fuel odor (in engine compartment)		x									x							
21	Engine noise																		
22	Vibration concerns (engine)																		
23	A/C does not work sufficiently.																		
24	A/C is always on or A/C compressor runs continuously.																		
25	A/C does not cut off under wide open throttle conditions.																		
26	Exhaust sulphur smell														x				
27	Fuel refill concerns														x				
28	Fuel filling shut off issues														x				
29	Intermittent concerns	x			x					x	x	x			x	x	x	x	
30	Constant voltage																		
31	Spark plug condition	x	x					x								x			
32	Automatic transaxle concerns																		
Upshift/downshift/engagement		See 05-03 AUTOMATIC TRANSAXLE SYMPTOM TROUBLESHOOTING																	

# SYMPTOM TROUBLESHOOTING [ENGINE CONTROL SYSTEM (FS)]

× : Applied

Troubleshooting item		Possible factor																		
		Neutral or clutch switch and related circuit malfunction (MTX)	MAF sensor and related circuit malfunction	TP sensor and related circuit malfunction	TP sensor misadjustment (Including looseness)	Power steering pressure switch and related circuit malfunction	Improper refrigerant charging amount	A/C relay (A/C control signal) circuit malfunction	Condenser fan system malfunction	Improper load signal input	Clutch slippage	Automatic transaxle related parts malfunction	VSS and related circuit malfunction	Improper ATF level	Brake dragging	Loose parts	Wheels and tires improper balance	Driveline malfunction	Suspension malfunction	
1	Melting main or other fuses																			
2	MIL illuminates.																			
3	Will not crank																			
4	Hard start/long crank/erratic start/erratic crank		×																	
5	Engine stalls.      After start/at idle						×	×	×											
6	Cranks normally but will not start																			
7	Slow return to idle										×									
8	Engine runs rough/rolling idle					×	×	×	×	×										
9	Fast idle/runs on									×										
10	Low idle/stalls during deceleration	×	×	×	×			×												
11	Engine stalls/quits.      Acceleration/cruise		×	×	×			×	×	×		×	×	×						
	Engine runs rough.      Acceleration/cruise		×	×	×			×	×	×		×	×	×						
	Misses      Acceleration/cruise		×	×	×			×	×	×		×	×	×						
	Buck/jerk      Acceleration/cruise/deceleration		×	×	×			×	×	×		×	×	×						
	Hesitation/stumble      Acceleration		×	×	×			×	×	×		×	×	×						
	Surges      Acceleration/cruise		×	×	×			×	×	×		×	×	×						
12	Lack/loss of power      Acceleration/cruise							×	×	×		×	×	×		×				
13	Knocking/pinging      Acceleration/cruise		×																	
14	Poor fuel economy									×					×	×				
15	Emissions compliance																			
16	High oil consumption/leakage																			
17	Cooling system concerns      Overheating							×	×	×										
18	Cooling system concerns      Runs cold									×										
19	Exhaust smoke																			
20	Fuel odor (in engine compartment)																			
21	Engine noise																×			
22	Vibration concerns (engine)																	×	×	×
23	A/C does not work sufficiently.							×	×	×										
24	A/C is always on or A/C compressor runs continuously.								×	×										
25	A/C does not cut off under wide open throttle conditions.			×	×															
26	Exhaust sulphur smell																			
27	Fuel refill concerns																			
28	Fuel filling shut off issues																			
29	Intermittent concerns	×	×	×		×		×				×								
30	Constant voltage																			
31	Spark plug condition		×																	
32	Automatic transaxle concerns      Upshift/downshift/engagement																			

See 05-03 AUTOMATIC TRANSAXLE SYMPTOM TROUBLESHOOTING

# SYMPTOM TROUBLESHOOTING [ENGINE CONTROL SYSTEM (FS)]

## NO.1 MELTING OF MAIN OR OTHER FUSES [FS]

A3U010318881W06

### 1 Melting of main or other fuses

#### [TROUBLESHOOTING HINTS]

Inspection condition of fuse.

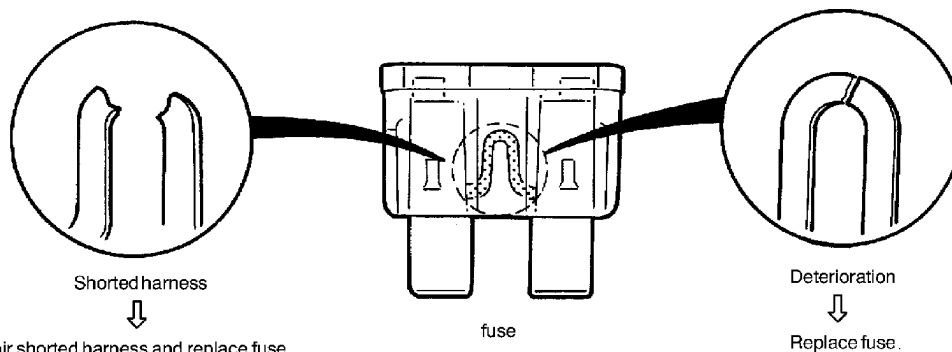

Damaged Fuse	Related Wiring Harness
MAIN (100A)	<b>MAIN fuse</b> ● Generator
IG KEY (60A)	<b>IG KEY fuse</b> ● Ignition key
A/C (15A)	<b>A/C fuse</b> ● A/C relay ● Condenser fan relay
A/C (10A)	<b>A/C relay</b> ● Magnetic clutch
AD FAN (30A)	<b>Condenser fan relay</b> ● Condenser fan motor
INJ (30A)	<b>INJ fuse</b> ● PCM <b>Main relay</b> ● PCM ● Fuel pump relay ● Fuel injectors ● Purge solenoid valve ● PRC solenoid valve ● VICS solenoid valve ● VTCS solenoid valve <b>Fuel pump relay</b> ● Fuel pump ● Mass air flow sensor ● Vehicle speedometer sensor ● EGR valve ● EGR check solenoid valve ● CDCV
ENGINE (10A)	<b>ENGINE fuse</b> ● Ignition coil ● Condenser ● Heated oxygen sensor ● Main relay ● Cooling fan relay ● Malfunction indicator lamp
METER (10A)	<b>METER fuse</b> ● Transaxle range switch (ATX) ● O/D OFF indicator light (ATX)
COOLING FAN (30A)	<b>Cooling fan relay</b> ● Cooling fan motor

- If malfunction remains, refer to related Service Bulletins and perform repair or diagnosis.
  - If vehicle is repaired, troubleshooting completed.
  - If vehicle is not repaired or additional diagnostic information is not available, repair PCM.

01-03B



# SYMPTOM TROUBLESHOOTING [ENGINE CONTROL SYSTEM (FS)]

## NO.2 MIL ILLUMINATES [FS]

A3U010318881W07

<b>2</b>	<b>MIL illuminates</b>
<b>DESCRIPTION</b>	MIL is illuminated incorrectly.
<b>POSSIBLE CAUSE</b>	<ul style="list-style-type: none"> <li>• PCM illuminates for emission-related concern (DTC is stored in PCM)</li> <li>• Short to ground circuit between MIL (located on instrument cluster) and PCM</li> </ul> <p><b>Note</b></p> <ul style="list-style-type: none"> <li>• If MIL blinks at steady rate, misfire condition could possibly exist.</li> </ul>

### Diagnostic procedure

STEP	INSPECTION	RESULTS	ACTION
1	<ul style="list-style-type: none"> <li>• Connect WDS or equivalent to DLC-2.</li> <li>• Retrieve any DTC.</li> <li>• Turn ignition key to ON.</li> <li>• Is "DTC" displayed?</li> </ul>	Yes	<b>No DTC is displayed:</b> <ul style="list-style-type: none"> <li>• Inspect for short to ground circuit between MIL (located on instrument cluster) and PCM terminal 2.</li> </ul>
		No	<b>DTC is displayed:</b> <ul style="list-style-type: none"> <li>• Go to appropriate DTC test.</li> </ul>
2	<ul style="list-style-type: none"> <li>• Verify test results.                             <ul style="list-style-type: none"> <li>— If okay, return to diagnostic index to service any additional symptoms.</li> <li>— If malfunction remains, inspect related Service Bulletins and perform repair or diagnosis.                                     <ul style="list-style-type: none"> <li>• If vehicle is repaired, troubleshooting completed.</li> <li>• If vehicle is not repaired or additional diagnostic information is not available, replace PCM.</li> </ul> </li> </ul> </li> </ul>		

## NO.3 WILL NOT CRANK [FS]

A3U010318881W08

<b>3</b>	<b>Will not crank</b>
<b>DESCRIPTION</b>	<ul style="list-style-type: none"> <li>• Starter does not work.</li> </ul>
<b>POSSIBLE CAUSE</b>	<ul style="list-style-type: none"> <li>• Open starter circuit between ignition key and starter</li> <li>• Transaxle range switch malfunction (ATX)</li> <li>• Transaxle range switch misadjustment (ATX)</li> <li>• Starter interlock switch malfunction (MTX)</li> <li>• Starter malfunction</li> <li>• Seized/hydrolocked engine, flywheel (MTX) or drive plate (ATX)</li> </ul>

### Diagnostic procedure

STEP	INSPECTION	RESULTS	ACTION
1	<ul style="list-style-type: none"> <li>• Inspect for following:                             <ul style="list-style-type: none"> <li>— Battery connection</li> <li>— Battery condition</li> <li>— Transaxle is in Park or Neutral. (ATX)</li> <li>— Clutch is fully depressed. (MTX)</li> <li>— Fuses</li> </ul> </li> <li>• Are all items okay?</li> </ul>	Yes	Go to next step.
		No	Service as necessary. Repeat Step 1.
2	<ul style="list-style-type: none"> <li>• Is clicking sound heard from starter when ignition key is turned to START?</li> </ul>	Yes	Go to next step.
		No	Go to Step 4.
3	<ul style="list-style-type: none"> <li>• Inspect starting system. (See 01-19-2 STARTER INSPECTION.)</li> <li>• Is starting system okay?</li> </ul>	Yes	Inspect for seized/hydrolocked engine, flywheel (MTX) or drive plate (ATX).
		No	Repair or replace components as required.
4	<ul style="list-style-type: none"> <li>• Do any other electrical accessories work?</li> </ul>	Yes	Go to next step.
		No	Inspect charging system. (See 01-17-1 BATTERY INSPECTION.) (See 01-17-3 GENERATOR INSPECTION.)
5	<p><b>Note</b></p> <ul style="list-style-type: none"> <li>• Following test should be performed on ATX only. For MTX, go to next step.</li> <li>• Inspect adjustment of transaxle range switch.</li> <li>• Is transaxle range switch adjusted properly?</li> </ul>	Yes	Go to next step.
		No	Inspect for open circuit between transaxle range switch and PCM terminal 64 or starter.

## SYMPTOM TROUBLESHOOTING [ENGINE CONTROL SYSTEM (FS)]

STEP	INSPECTION	RESULTS	ACTION
6	<ul style="list-style-type: none"> <li>Connect WDS or equivalent to DLC-2.</li> <li>Turn ignition key to ON.</li> <li>Retrieve any DTC.</li> <li>Is "DTC" displayed?</li> </ul>	Yes	<b>No DTC displayed:</b> <ul style="list-style-type: none"> <li>Inspect following:                             <ul style="list-style-type: none"> <li>START circuit in ignition key</li> <li>Open circuit between ignition key and starter</li> <li>Starter interlock switch (MTX)</li> </ul> </li> </ul>
		No	<b>DTC displayed:</b> <ul style="list-style-type: none"> <li>Go to appropriate DTC test.</li> </ul> <b>Communication error message displayed:</b> <ul style="list-style-type: none"> <li>Inspect for following:                             <ul style="list-style-type: none"> <li>Open circuit between main relay and PCM terminal 71 or 97</li> <li>Open main relay GND circuit</li> <li>Main relay is stuck open.</li> <li>Open or poor GND circuit (PCM terminal 24, 51, 76, 77, or 103)</li> <li>Poor connection of vehicle body GND</li> </ul> </li> </ul>
7	<ul style="list-style-type: none"> <li>Verify test results.                             <ul style="list-style-type: none"> <li>If okay, return to diagnostic index to service any additional symptoms.</li> <li>If malfunction remains, refer to related Service Bulletins and perform repair or diagnosis.                                     <ul style="list-style-type: none"> <li>If vehicle is repaired, troubleshooting completed.</li> <li>If vehicle is not repaired or additional diagnostic information is not available, replace PCM.</li> </ul> </li> </ul> </li> </ul>		

01-03B

### NO.4 HARD START/LONG CRANK/ERRATIC START/ERRATIC CRANK [FS]

A3U010318881W09

4	Hard to start/long crank/erratic start/erratic crank
DESCRIPTION	<ul style="list-style-type: none"> <li>Starter cranks engine at normal speed but engine requires excessive cranking time before starting.</li> <li>Battery is in normal condition.</li> </ul>
POSSIBLE CAUSE	<ul style="list-style-type: none"> <li>Spark leakage from high-tension leads</li> <li>Vacuum leakage</li> <li>Poor fuel quality</li> <li>Starting system malfunction</li> <li>Spark plug malfunction</li> <li>Air leakage from intake-air system</li> <li>Erratic signal from CKP sensor</li> <li>Erratic signal from CMP sensor</li> <li>Air cleaner restriction</li> <li>IAC valve malfunction</li> <li>PCV valve malfunction</li> <li>Inadequate fuel pressure</li> <li>Purge solenoid valve malfunction</li> <li>MAF sensor contamination</li> <li>Restriction in exhaust system</li> <li>EGR valve malfunction</li> <li>Pressure regulator control (PRC) system malfunction</li> </ul> <p><b>Warning</b>  <b>The following troubleshooting flow chart contains fuel system diagnosis and repair procedures. Read following warnings before performing fuel system services:</b></p> <ul style="list-style-type: none"> <li><b>Fuel vapor is hazardous. It can easily ignite, causing serious injury and damage. Always keep sparks and flames away from fuel.</b></li> <li><b>Fuel line spills and leakage are dangerous. Fuel can ignite and cause serious injuries or death and damage. Fuel can also irritate skin and eyes. To prevent this, always complete "BEFORE REPAIR PROCEDURE" and "AFTER REPAIR PROCEDURE" described in this manual.</b>                      (See 01-14-4 BEFORE REPAIR PROCEDURE.)                      (See 01-14-5 AFTER REPAIR PROCEDURE.)</li> </ul>

#### Diagnostic procedure

STEP	INSPECTION	RESULTS	ACTION
1	<ul style="list-style-type: none"> <li>Inspect for following:                             <ul style="list-style-type: none"> <li>Vacuum leakage</li> <li>Fuel quality (e.g. proper octane, contamination, winter/summer blend)</li> <li>Loose bands on intake-air system</li> <li>Cracks on intake-air system parts</li> <li>Air cleaner restriction</li> </ul> </li> <li>Are all items okay?</li> </ul>	Yes	Go to next step.
		No	Service as necessary.

## SYMPTOM TROUBLESHOOTING [ENGINE CONTROL SYSTEM (FS)]

STEP	INSPECTION	RESULTS	ACTION
2	<ul style="list-style-type: none"> <li>Connect WDS or equivalent to DLC-2.</li> <li>Turn ignition key to ON.</li> <li>Retrieve any DTC.</li> <li>Is "DTC" displayed?</li> </ul>	Yes	<b>DTC displayed:</b> <ul style="list-style-type: none"> <li>Go to appropriate DTC test.</li> </ul>
		No	<b>No DTC displayed:</b> <ul style="list-style-type: none"> <li>Go to next step.</li> </ul>
3	<ul style="list-style-type: none"> <li>Is engine overheating?</li> </ul>	Yes	Go to symptom troubleshooting "NO.17 COOLING SYSTEM CONCERNS - OVERHEATING [FS]."
		No	Go to next step.
4	<ul style="list-style-type: none"> <li>Inspect for cracks on high-tension leads.</li> <li>Are there any cracks on high-tension leads?</li> </ul>	Yes	Repair suspected high-tension leads.
		No	Go to next step.
5	<ul style="list-style-type: none"> <li>Inspect condition of spark plugs.</li> <li>Is spark plug wet, covered with carbon or grayish white?</li> </ul>	Yes	<b>Spark plug is wet or covered with carbon:</b> <ul style="list-style-type: none"> <li>Inspect for fuel leakage from fuel injector.</li> </ul> <b>Spark plug is grayish white:</b> <ul style="list-style-type: none"> <li>Inspect for clogged fuel injector.</li> </ul>
		No	Install spark plugs on original cylinders. Go to next step.
6	<ul style="list-style-type: none"> <li>Visually inspect CKP sensor and teeth of crankshaft pulley.</li> <li>Are CKP sensor and teeth of crankshaft pulley okay?</li> </ul>	Yes	Go to next step.
		No	Replace malfunctioning parts.
7	<ul style="list-style-type: none"> <li>Measure gap between CKP sensor and teeth of crankshaft pulley.</li> </ul> <b>Specification</b> <b>0.5—1.5 mm {0.020—0.59 in}</b> <ul style="list-style-type: none"> <li>Is gap within specification?</li> </ul>	Yes	Go to next step.
		No	Adjust CKP sensor.
8	<ul style="list-style-type: none"> <li>Remove and inspect PCV valve.</li> <li>Does PCV valve rattle?</li> </ul>	Yes	Go to next step.
		No	Replace PCV valve.
9	<ul style="list-style-type: none"> <li>Install fuel pressure gauge between fuel filter and fuel distributor.</li> <li>Connect jumper wire between F/P terminal at DLC in engine compartment and GND. (See 01-14-5 AFTER REPAIR PROCEDURE.)</li> <li>Turn ignition key to ON.</li> <li>Is fuel line pressure correct?</li> </ul> <b>Fuel line pressure</b> <b>270—310 kPa {2.7—3.2 kgf/cm<sup>2</sup>, 39—45 psi}</b>	Yes	Go to next step.
		No	<b>Zero or low:</b> <ul style="list-style-type: none"> <li>Inspect fuel pump circuit.</li> <li>Inspect for open fuel pump relief valve.</li> <li>Inspect for fuel leakage inside pressure regulator.</li> <li>Inspect for clogged main fuel line.</li> <li>Inspect PRC solenoid valve and related vacuum hose and harness.</li> </ul> <b>High</b> <ul style="list-style-type: none"> <li>Inspect pressure regulator for high pressure cause.</li> <li>Inspect for clogged fuel return line.</li> </ul>
10	<ul style="list-style-type: none"> <li>Is fuel line pressure held after ignition key is turned to LOCK? (See 01-14-28 Operation Inspection.)</li> </ul>	Yes	Go to next step.
		No	Inspect pressure regulator diaphragm condition. If condition is okay, inspect fuel injector. If condition is not okay, replace pressure regulator.
11	<ul style="list-style-type: none"> <li>Disconnect vacuum hose from pressure regulator and plug the hose.</li> <li>Start engine.</li> <li>Does fuel line pressure remain within <math>\pm 20</math> kPa {0.21 kgf/cm<sup>2</sup>, 3 psi} while driving vehicle?</li> </ul>	Yes	Go to next step.
		No	Inspect for clogged fuel filter.
12	<ul style="list-style-type: none"> <li>Connect vacuum hose to pressure regulator.</li> <li>Install vacuum gauge to intake manifold.</li> <li>Start engine.</li> <li>Does fuel pressure gauge reading increase as vacuum gauge reading decreases and/or fuel pressure gauge reading decrease as vacuum gauge reading increases?</li> </ul>	Yes	Go to next step.
		No	Connect vacuum pump to pressure regulator. Start engine. Verify that fuel pressure gauge reading changes as vacuum changes. If changes, inspect vacuum line. If does not change, replace pressure regulator.
13	<ul style="list-style-type: none"> <li>Disconnect vacuum hose from purge solenoid valve and plug opening end of vacuum hose.</li> <li>Attempt to start engine.</li> <li>Is starting condition improved?</li> </ul>	Yes	Inspect if purge solenoid valve is stuck open.
		No	Go to next step.
14	<ul style="list-style-type: none"> <li>Inspect MAF sensor for contamination.</li> <li>Is there any contamination?</li> </ul>	Yes	Replace MAF sensor.
		No	Go to next step.
15	<ul style="list-style-type: none"> <li>Is there a restriction in exhaust system?</li> </ul>	Yes	Inspect exhaust system.
		No	Go to next step.

## SYMPTOM TROUBLESHOOTING [ENGINE CONTROL SYSTEM (FS)]

STEP	INSPECTION	RESULTS	ACTION
16	<ul style="list-style-type: none"> <li>Inspect engine condition while tapping EGR valve housing.</li> <li>Does engine condition improve?</li> </ul>	Yes	Replace EGR valve.
		No	Go to next step.
17	<ul style="list-style-type: none"> <li>Inspect starting system. (See 01-19-2 STARTER INSPECTION.)</li> <li>Is starting system normal?</li> </ul>	Yes	Inspect for loose connectors or poor terminal contact. If okay, remove EGR valve and visually inspect for mechanically stuck EGR valve.
		No	Repair or replace components as required.
18	<ul style="list-style-type: none"> <li>Verify test results.                             <ul style="list-style-type: none"> <li>If okay, return to diagnostic index to service any additional symptoms.</li> <li>If malfunction remains, refer to related Service Bulletins and perform repair or diagnosis.                                     <ul style="list-style-type: none"> <li>If vehicle is repaired, troubleshooting completed.</li> <li>If vehicle is not repaired or additional diagnostic information is not available, replace PCM.</li> </ul> </li> </ul> </li> </ul>		

01-03B

### NO.5 ENGINE STALLS-AFTER START/AT IDLE [FS]

A3U010318881W10

5	Engine stalls—After start/at idle
<b>DESCRIPTION</b>	<ul style="list-style-type: none"> <li>Engine stops unexpectedly at idle and/or after start.</li> </ul>
<b>POSSIBLE CAUSE</b>	<ul style="list-style-type: none"> <li>A/C system improper operation</li> <li>Air leakage from intake-air system parts</li> <li>Purge solenoid valve malfunction</li> <li>Improper operation of IAC valve</li> <li>EGR valve malfunction</li> <li>No signal from CKP sensor due to sensor, related wire or wrong installation</li> <li>Vacuum leakage</li> <li>Low engine compression</li> <li>Spark leakage from high-tension leads</li> <li>Poor fuel quality</li> <li>PCV valve malfunction</li> <li>Air cleaner restriction</li> <li>Restriction in exhaust system</li> <li>Electrical connector disconnection</li> <li>Open or short circuit in fuel pump and related harness</li> <li>No battery power supply to PCM or poor GND</li> <li>Inadequate fuel pressure</li> <li>Fuel pump mechanical malfunction</li> <li>Fuel leakage from fuel injector</li> <li>Fuel injector clogging</li> <li>Immobilizer system and/or circuit malfunction</li> <li>Pressure regulator control (PRC) system malfunction</li> </ul> <p><b>Warning</b>                      The following troubleshooting flow chart contains fuel system diagnosis and repair procedures. Read following warnings before performing fuel system services:</p> <ul style="list-style-type: none"> <li>Fuel vapor is hazardous. It can easily ignite, causing serious injury and damage. Always keep sparks and flames away from fuel.</li> <li>Fuel line spills and leakage are dangerous. Fuel can ignite and cause serious injuries or death and damage. Fuel can also irritate skin and eyes. To prevent this, always complete "BEFORE REPAIR PROCEDURE" and "AFTER REPAIR PROCEDURE" described in this manual.</li> </ul> <p>(See 01-14-4 BEFORE REPAIR PROCEDURE.)                      (See 01-14-5 AFTER REPAIR PROCEDURE.)</p>

## SYMPTOM TROUBLESHOOTING [ENGINE CONTROL SYSTEM (FS)]

### Diagnostic procedure

STEP	INSPECTION	RESULTS	ACTION
1	<ul style="list-style-type: none"> <li>• Inspect for following:                             <ul style="list-style-type: none"> <li>— Vacuum connection</li> <li>— Air cleaner element</li> <li>— No air leakage from intake-air system</li> <li>— No restriction of intake-air system</li> <li>— Proper sealing of intake manifold and components attached to intake manifold: EGR valve, IAC valve</li> <li>— Ignition wiring</li> <li>— Fuel quality: proper octane, contamination, winter/summer blend</li> <li>— Electrical connections</li> <li>— Smooth operation of throttle</li> </ul> </li> <li>• Are all items okay?</li> </ul>	Yes	Go to next step.
		No	Service as necessary. Repeat Step 1.
2	<ul style="list-style-type: none"> <li>• Turn ignition key to ON.</li> <li>• Disconnect TP sensor connector.</li> <li>• Measure voltage at TP sensor connector VREF terminal with ignition key on.</li> </ul> <b>Voltage</b> <b>4.5—5.5 V</b> <ul style="list-style-type: none"> <li>• Is voltage okay?</li> </ul>	Yes	Go to next step.
		No	Go to symptom troubleshooting “NO.30 REFERENCE VOLTAGE [FS].”
3	<ul style="list-style-type: none"> <li>• Connect WDS or equivalent to DLC-2.</li> <li>• Retrieve any DTC.</li> <li>• Turn ignition key to ON.</li> <li>• Is “DTC” displayed?</li> </ul>	Yes	<b>DTC is displayed:</b> <ul style="list-style-type: none"> <li>• Go to appropriate DTC test.</li> </ul> <b>Communication error message is displayed:</b> <ul style="list-style-type: none"> <li>• Inspect for following:                             <ul style="list-style-type: none"> <li>— Open circuit between main relay and PCM terminal 71 or 97</li> <li>— Open main relay GND circuit</li> <li>— Main relay is stuck open.</li> <li>— Open or poor GND circuit (PCM terminal 24, 51, 76, 77 or 103)</li> <li>— Poor connection of vehicle body GND</li> </ul> </li> </ul>
		No	<b>No DTC is displayed:</b> <ul style="list-style-type: none"> <li>• Go to next step.</li> </ul>
4	<ul style="list-style-type: none"> <li>• Attempt to start engine at part throttle.</li> <li>• Does engine run smoothly at part throttle?</li> </ul>	Yes	Inspect IAC valve and wiring harness.
		No	Go to next step.
5	<ul style="list-style-type: none"> <li>• Connect WDS or equivalent to DLC-2.</li> <li>• Access RPM PID.</li> <li>• Is RPM PID indicating engine speed during cranking of engine?</li> </ul>	Yes	Go to next step.
		No	Inspect for following: <ul style="list-style-type: none"> <li>• Open or short circuit in CKP sensor</li> <li>• Open or short circuit between CKP sensor and PCM terminal 21 or 22</li> <li>• Open or short circuit in CKP sensor harnesses</li> </ul> If CKP sensor and harness are okay, go to next step.
6	<ul style="list-style-type: none"> <li>• Visually inspect CKP sensor and teeth of crankshaft pulley.</li> <li>• Are CKP sensor and teeth of crankshaft pulley okay?</li> </ul>	Yes	Go to next step.
		No	Replace malfunctioning parts.
7	<ul style="list-style-type: none"> <li>• Measure gap between CKP sensor and teeth of crankshaft pulley.</li> </ul> <b>Gap</b> <b>0.5—1.5 mm {0.020—0.059 in}</b> <ul style="list-style-type: none"> <li>• Is gap within specification?</li> </ul>	Yes	Go to next step.
		No	Adjust CKP sensor.
8	<ul style="list-style-type: none"> <li>• Inspect for cracks on high-tension leads.</li> <li>• Are there any cracks on high-tension leads?</li> </ul>	Yes	Repair suspected high-tension leads.
		No	Go to next step.
9	<ul style="list-style-type: none"> <li>• Is strong blue spark visible at each disconnected high-tension lead during engine cranking?</li> </ul>	Yes	Go to next step. If symptom occurs with A/C on, go to Step 15.
		No	Inspect for following: <ul style="list-style-type: none"> <li>• Open or short circuit in ignition coil</li> <li>• Open circuit in high-tension leads</li> <li>• Open circuit between ignition coil connector GND terminal and body GND</li> <li>• Open circuit between ignition key and ignition coil</li> <li>• Open circuit between ignition coil and PCM terminal 26 or 52</li> </ul>

## SYMPTOM TROUBLESHOOTING [ENGINE CONTROL SYSTEM (FS)]

STEP	INSPECTION	RESULTS	ACTION
10	<ul style="list-style-type: none"> <li>Inspect condition of spark plugs.</li> <li>Is spark plug wet, covered with carbon or grayish white?</li> </ul>	Yes	<b>Spark plug is wet or covered with carbon:</b> <ul style="list-style-type: none"> <li>Inspect for fuel leakage from injector.</li> </ul> <b>Spark plug is grayish white:</b> <ul style="list-style-type: none"> <li>Inspect for clogged fuel injector.</li> </ul>
		No	Install spark plugs on original cylinders. Go to next step.
11	<ul style="list-style-type: none"> <li>Remove and shake PCV valve.</li> <li>Does PCV valve rattle?</li> </ul>	Yes	Go to next step.
		No	Replace PCV valve.
12	<ul style="list-style-type: none"> <li>Inspect for a restriction in exhaust system.</li> <li>Is there any restriction?</li> </ul>	Yes	Inspect exhaust system.
		No	Go to next step.
13	<ul style="list-style-type: none"> <li>Install fuel pressure gauge between fuel filter and fuel distributor.</li> <li>Connect jumper wire between F/P terminal at DLC in engine compartment and GND.</li> <li>Turn ignition key to ON.</li> <li>Is fuel line pressure correct with ignition key on?</li> </ul> <b>Fuel line pressure</b> <b>270—310 kPa {2.7—3.2 kgf/cm<sup>2</sup>, 39—45 psi}</b>	Yes	Go to next step.
		No	<b>Zero or low:</b> <ul style="list-style-type: none"> <li>Inspect fuel pump circuit.</li> <li>Inspect for open fuel pump relief valve.</li> <li>Inspect for fuel leakage inside pressure regulator.</li> <li>Inspect for clogged main fuel line.</li> <li>Inspect PRC solenoid valve and related vacuum hose and harness.</li> </ul> <b>High</b> <ul style="list-style-type: none"> <li>Inspect pressure regulator for high pressure cause.</li> <li>Inspect for clogged fuel return line.</li> </ul>
14	<ul style="list-style-type: none"> <li>Visually inspect for fuel leakage at fuel injector O-ring and fuel line.</li> <li>Service as necessary.</li> <li>Does fuel line pressure hold after ignition key is turned to LOCK? (See 01-14-28 PRESSURE REGULATOR INSPECTION.)</li> </ul>	Yes	Go to next step.
		No	Inspect pressure regulator diaphragm condition. If condition is okay, inspect fuel injector. If condition is not okay, replace pressure regulator.
15	<b>Note</b> <ul style="list-style-type: none"> <li>The following test is for stall concerns with A/C on. If other symptoms exist, go to next step.</li> <li>Connect pressure gauges to A/C low and high pressure side lines.</li> <li>Turn A/C on and measure low side and high side pressures.</li> <li>Are pressures within specifications? (See 07-10-3 REFRIGERANT PRESSURE CHECK.)</li> </ul>	Yes	Go to next step.
		No	If A/C is always on, go to symptom troubleshooting "NO.24 A/C IS ALWAYS ON OR A/C COMPRESSOR RUNS CONTINUOUSLY [FS]." For other symptoms, inspect following: <ul style="list-style-type: none"> <li>Refrigerant charging amount</li> <li>Condenser fan operation</li> </ul>
16	<ul style="list-style-type: none"> <li>Disconnect vacuum hose between purge solenoid valve and intake manifold from purge solenoid side.</li> <li>Plug opening end of vacuum hose.</li> <li>Start engine.</li> <li>Is engine stall now eliminated?</li> </ul>	Yes	Inspect if purge solenoid valve is stuck open. Inspect evaporative emission control system.
		No	Go to next step.
17	<ul style="list-style-type: none"> <li>Is air leakage felt or heard at intake-air system components while racing engine to higher speed?</li> </ul>	Yes	Repair or replace faulty part.
		No	Go to next step.
18	<ul style="list-style-type: none"> <li>Inspect engine condition while tapping EGR valve housing</li> <li>Does engine condition improve?</li> </ul>	Yes	Replace EGR valve.
		No	Go to next step.
19	<ul style="list-style-type: none"> <li>Is engine compression correct?</li> </ul>	Yes	Inspect valve timing.
		No	Inspect for cause.
20	<ul style="list-style-type: none"> <li>Verify test results.                             <ul style="list-style-type: none"> <li>If okay, return to diagnostic index to service any additional symptoms.</li> <li>If malfunction remains, refer to related Service Bulletins and perform repair or diagnosis.                                     <ul style="list-style-type: none"> <li>If vehicle is repaired, troubleshooting completed.</li> <li>If vehicle is not repaired or additional diagnostic information is not available, replace PCM.</li> </ul> </li> </ul> </li> </ul>		

01-03B

# SYMPTOM TROUBLESHOOTING [ENGINE CONTROL SYSTEM (FS)]

## NO.6 CRANKS NORMALLY BUT WILL NOT START [FS]

A3U010318881W11

<b>6</b>	<b>Cranks normally but will not start</b>
<b>DESCRIPTION</b>	<ul style="list-style-type: none"> <li>• Starter cranks engine at normal speed but engine will not run.</li> <li>• Refer to “ENGINE STALLS” if this symptom appears after engine stall.</li> <li>• Fuel is in tank.</li> <li>• Battery is in normal condition.</li> </ul>
<b>POSSIBLE CAUSE</b>	<ul style="list-style-type: none"> <li>• No battery power supply to PCM</li> <li>• Air leakage from intake-air system</li> <li>• Open PCM GND or vehicle body GND</li> <li>• Improper operation of IAC valve</li> <li>• EGR valve malfunction</li> <li>• No signal from CKP sensor due to sensor, related wire or incorrect installation</li> <li>• No signal from CMP sensor due to sensor, related wire or incorrect installation</li> <li>• Low engine compression</li> <li>• Vacuum leakage</li> <li>• Spark leakage from high-tension leads</li> <li>• Poor fuel quality</li> <li>• PCV valve malfunction</li> <li>• Air cleaner restriction</li> <li>• Restriction in exhaust system</li> <li>• Disconnected electrical connector</li> <li>• Open or short circuit in fuel pump and related harness</li> <li>• Inadequate fuel pressure</li> <li>• Fuel pump mechanical malfunction</li> <li>• Fuel leakage from injector</li> <li>• Fuel injector clogging</li> <li>• Purge solenoid valve malfunction</li> <li>• Pressure regulator solenoid (PRC) system malfunction</li> </ul> <p><b>Warning</b>  <b>The following troubleshooting flow chart contains fuel system diagnosis and repair procedures. Read following warnings before performing fuel system services:</b></p> <ul style="list-style-type: none"> <li>• Fuel vapor is hazardous. It can easily ignite, causing serious injury and damage. Always keep sparks and flames away from fuel.</li> <li>• Fuel line spills and leakage are dangerous. Fuel can ignite and cause serious injuries or death and damage. Fuel can also irritate skin and eyes. To prevent this, always complete “BEFORE REPAIR PROCEDURE” and “AFTER REPAIR PROCEDURE” described in this manual.                      (See 01-14-4 BEFORE REPAIR PROCEDURE.)                      (See 01-14-5 AFTER REPAIR PROCEDURE.)</li> </ul>

### Diagnostic procedure

STEP	INSPECTION	RESULTS	ACTION
1	<ul style="list-style-type: none"> <li>• Verify following:                             <ul style="list-style-type: none"> <li>— Vacuum connection</li> <li>— External fuel shut off or accessory (kill switch, alarm etc.)</li> <li>— Fuel quality: proper octane, contamination, winter/summer blend</li> <li>— No air leakage from intake-air system</li> <li>— Proper sealing of intake manifold and components attached to intake manifold: EGR valve, IAC valve</li> <li>— Ignition wiring</li> <li>— Electrical connections</li> <li>— Fuses</li> <li>— Smooth operation of throttle</li> </ul> </li> <li>• Are all items okay?</li> </ul>	Yes  No	Go to next step.  Service as necessary. Repeat Step 1.

## SYMPTOM TROUBLESHOOTING [ENGINE CONTROL SYSTEM (FS)]

STEP	INSPECTION	RESULTS	ACTION
2	<ul style="list-style-type: none"> <li>Connect WDS or equivalent to DLC-2.</li> <li>Turn ignition key to ON.</li> <li>Retrieve any DTC.</li> <li>Is "DTC" displayed?</li> </ul>	Yes	<b>DTC displayed:</b> <ul style="list-style-type: none"> <li>Go to appropriate DTC test.</li> </ul> <b>Communication error message displayed:</b> <ul style="list-style-type: none"> <li>Inspect for following:                             <ul style="list-style-type: none"> <li>Open circuit between main relay and PCM terminal 71 or 97</li> <li>Open main relay GND circuit</li> <li>Main relay is stuck open.</li> <li>Open or poor GND circuit (PCM terminal 24, 51, 76, 77, or 103)</li> <li>Poor connection of vehicle body GND</li> </ul> </li> </ul>
		No	<b>No DTC displayed:</b> <ul style="list-style-type: none"> <li>Go to next step.</li> </ul>
3	<ul style="list-style-type: none"> <li>Turn ignition key to LOCK.</li> <li>Disconnect TP sensor connector.</li> <li>Measure voltage at TP sensor connector VREF terminal with ignition key on.</li> </ul> <b>Voltage</b> <b>4.5—5.5 V</b> <ul style="list-style-type: none"> <li>Is voltage okay?</li> </ul>	Yes	Go to next step.
		No	Go to symptom troubleshooting "NO.30 REFERENCE VOLTAGE [FS]."
4	<ul style="list-style-type: none"> <li>Does engine start with throttle closed?</li> </ul>	Yes	Go to Step 20.
		No	Go to next step.
5	<ul style="list-style-type: none"> <li>Will engine start and run smoothly at part throttle?</li> </ul>	Yes	Inspect IAC valve and wiring harness.
		No	Go to next step.
6	<ul style="list-style-type: none"> <li>Connect WDS or equivalent to DLC-2.</li> <li>Access RPM PID.</li> <li>Is RPM PID indicating engine speed when cranking engine?</li> </ul>	Yes	Go to next step.
		No	Inspect for following: <ul style="list-style-type: none"> <li>Open or short circuit in CKP sensor</li> <li>Open or short circuit between CKP sensor and PCM terminal 21 or 22</li> <li>Open or short circuit in CKP sensor harnesses</li> </ul> If CKP sensor and harness are okay, go to next step.
7	<ul style="list-style-type: none"> <li>Visually inspect CKP sensor and teeth of crankshaft pulley.</li> <li>Are CKP sensor and teeth of crankshaft pulley okay?</li> </ul>	Yes	Go to next step.
		No	Replace malfunctioning parts.
8	<ul style="list-style-type: none"> <li>Measure gap between CKP sensor and teeth of crankshaft pulley.</li> </ul> <b>Gap</b> <b>0.5—1.5 mm {0.020—0.059 in}</b> <ul style="list-style-type: none"> <li>Is gap within specification?</li> </ul>	Yes	Go to next step.
		No	Adjust CKP sensor.
9	<ul style="list-style-type: none"> <li>Inspect for cracks on high-tension leads.</li> <li>Are there any cracks, on high-tension leads?</li> </ul>	Yes	Repair suspected high-tension leads.
		No	Go to next step.
10	<ul style="list-style-type: none"> <li>Is strong blue spark visible at each disconnected high-tension lead during engine cranking?</li> </ul>	Yes	Go to next step.
		No	Inspect for following: <ul style="list-style-type: none"> <li>Open or short circuit in ignition coil</li> <li>Open circuit in high-tension leads</li> <li>Open circuit between ignition coil connector GND terminal and GND</li> <li>Open circuit between ignition key and ignition coil</li> <li>Open circuit between ignition coil and PCM terminal 26 or 52</li> </ul>
11	<ul style="list-style-type: none"> <li>Inspect condition of spark plugs.</li> <li>Is spark plug wet, covered with carbon or grayish white?</li> </ul>	Yes	<b>Spark plug is wet or covered with carbon:</b> <ul style="list-style-type: none"> <li>Inspect for fuel leakage from injector.</li> </ul> <b>Spark plug is grayish white:</b> <ul style="list-style-type: none"> <li>Inspect for clogged fuel injector.</li> </ul>
		No	Install spark plugs on original cylinders. Go to next step.
12	<ul style="list-style-type: none"> <li>Remove and shake PCV valve.</li> <li>Does PCV valve rattle?</li> </ul>	Yes	Go to next step.
		No	Replace PCV valve.
13	<ul style="list-style-type: none"> <li>Is there any restriction in exhaust system?</li> </ul>	Yes	Inspect exhaust system.
		No	Go to next step.

01-03B



## SYMPTOM TROUBLESHOOTING [ENGINE CONTROL SYSTEM (FS)]

STEP	INSPECTION	RESULTS	ACTION
14	<ul style="list-style-type: none"> <li>Install fuel pressure gauge between fuel filter and fuel distributor.</li> <li>Connect jumper wire between F/P terminal at DLC in engine compartment and GND.</li> <li>Turn ignition key to ON.</li> <li>Is fuel line pressure correct when ignition key is cycled on/off five times?</li> </ul> <b>Fuel line pressure</b> <b>270—310 kPa {2.7—3.2 kgf/cm<sup>2</sup>, 39—45 psi}</b>	Yes	Go to next step.
		No	<b>Zero or low:</b> <ul style="list-style-type: none"> <li>Inspect fuel pump circuit.</li> <li>Inspect for open fuel pump relief valve.</li> <li>Inspect for fuel leakage inside pressure regulator.</li> <li>Inspect for clogged main fuel line.</li> <li>Inspect PRC solenoid valve and related vacuum hose and harness.</li> </ul> <b>High:</b> <ul style="list-style-type: none"> <li>Inspect pressure regulator for high pressure cause.</li> <li>Inspect for clogged fuel return line.</li> </ul>
15	<ul style="list-style-type: none"> <li>Visually inspect for fuel leakage at fuel injector O-ring and fuel line.</li> <li>Service as necessary.</li> <li>Is fuel line pressure held after ignition key is turned to LOCK?</li> </ul> (See 01-14-28 Operation Inspection.)	Yes	Go to next step.
		No	Inspect pressure regulator diaphragm condition. If condition is okay, inspect fuel injector. If condition is not okay, replace pressure regulator.
16	<ul style="list-style-type: none"> <li>Disconnect vacuum hose between purge solenoid valve and intake manifold from purge solenoid valve side.</li> <li>Plug opening end of vacuum hose.</li> <li>Attempt to start engine.</li> <li>Is starting condition improved?</li> </ul>	Yes	Inspect if purge solenoid valve sticks open mechanically. Inspect evaporative emission control system.
		No	Go to next step.
17	<ul style="list-style-type: none"> <li>Is air leakage felt or heard at intake-air system components while racing engine to higher speed?</li> </ul>	Yes	Repair or replace.
		No	Go to next step.
18	<ul style="list-style-type: none"> <li>Inspect engine condition while tapping EGR valve housing.</li> <li>Does engine condition improve?</li> </ul>	Yes	Replace EGR valve.
		No	Go to next step.
19	<ul style="list-style-type: none"> <li>Is engine compression correct?</li> </ul>	Yes	Inspect valve timing.
		No	Inspect for causes.
20	<ul style="list-style-type: none"> <li>Verify test results.                             <ul style="list-style-type: none"> <li>— If okay, return to diagnostic index to service any additional symptoms.</li> <li>— If malfunction remains, refer to related Service Bulletins and perform repair or diagnosis.                                     <ul style="list-style-type: none"> <li>If vehicle is repaired, troubleshooting completed.</li> <li>If vehicle is not repaired or additional diagnostic information is not available, replace PCM.</li> </ul> </li> </ul> </li> </ul>		

### NO.7 SLOW RETURN TO IDLE [FS]

A3U010318881W12

7	Slow return to idle
<b>DESCRIPTION</b>	<ul style="list-style-type: none"> <li>Engine takes more time than normal to return to idle speed.</li> </ul>
<b>POSSIBLE CAUSE</b>	<ul style="list-style-type: none"> <li>ECT sensor malfunction</li> <li>Thermostat is stuck open.</li> <li>Throttle body malfunction</li> <li>Air leakage from intake-air system</li> </ul>

#### Diagnostic procedure

STEP	INSPECTION	RESULTS	ACTION
1	<ul style="list-style-type: none"> <li>Connect WDS or equivalent to DLC-2.</li> <li>Turn ignition key to ON.</li> <li>Retrieve any DTC.</li> <li>Is "DTC" displayed?</li> </ul>	Yes	<b>DTC displayed:</b> <ul style="list-style-type: none"> <li>Go to appropriate DTC test.</li> </ul>
		No	<b>No DTC displayed:</b> <ul style="list-style-type: none"> <li>Go to next step.</li> </ul>
2	<ul style="list-style-type: none"> <li>Remove thermostat and inspect operation. (See 01-12-5 THERMOSTAT REMOVAL/INSTALLATION.) (See 01-12-7 THERMOSTAT INSPECTION.)</li> <li>Is thermostat okay?</li> </ul>	Yes	ECT sensor and thermostat are okay. Go to next step.
		No	Access ECT PID on WDS or equivalent. Inspect for both ECT and temperature gauge on instrument cluster readings. <ul style="list-style-type: none"> <li>If temperature gauge on instrument cluster indicates normal range but ECT is not same as temperature gauge reading, inspect ECT sensor.</li> <li>If temperature gauge on instrument cluster indicates cold range but ECT is normal, inspect temperature gauge and heat gauge unit.</li> </ul>

## SYMPTOM TROUBLESHOOTING [ENGINE CONTROL SYSTEM (FS)]

STEP	INSPECTION	RESULTS	ACTION
3	<ul style="list-style-type: none"> <li>Is throttle body free of contaminations?</li> </ul>	Yes	Inspect for air leakage from intake-air system components while racing engine to higher speed.
		No	Clean or replace throttle body.
4	<ul style="list-style-type: none"> <li>Verify test results.                             <ul style="list-style-type: none"> <li>If okay, return to diagnostic index to service any additional symptoms.</li> <li>If malfunction remains, refer to related Service Bulletins and perform repair or diagnosis.                                     <ul style="list-style-type: none"> <li>If vehicle is repaired, troubleshooting completed.</li> <li>If vehicle is not repaired or additional diagnostic information is not available, replace PCM.</li> </ul> </li> </ul> </li> </ul>		

01-03B

### NO.8 ENGINE RUNS ROUGH/ROLLING IDLE [FS]

A3U010318881W13

8	Engine runs rough/rolling idle
<b>DESCRIPTION</b>	<ul style="list-style-type: none"> <li>Engine speed fluctuates between specified idle speed and lower speed and engine shakes excessively.</li> <li>Idle speed is too slow and engine shakes excessively.</li> </ul>
<b>POSSIBLE CAUSE</b>	<ul style="list-style-type: none"> <li>Air leakage from intake-air system parts</li> <li>A/C system improper operation</li> <li>Spark leakage from high-tension leads</li> <li>Purge solenoid valve malfunction</li> <li>IAC valve improper operation</li> <li>EGR valve malfunction</li> <li>Erratic or no signal from CMP sensor</li> <li>Low engine compression</li> <li>Erratic signal from CKP sensor</li> <li>Poor fuel quality</li> <li>PCV valve malfunction</li> <li>Air cleaner restriction</li> <li>Restriction in exhaust system</li> <li>Disconnected electrical connectors</li> <li>Inadequate fuel pressure</li> <li>Fuel pump mechanical malfunction</li> <li>Fuel leakage from fuel injector</li> <li>Fuel injector clogging</li> <li>Engine overheating</li> <li>Vacuum leakage</li> <li>Pressure regulator control (PRC) system malfunction</li> </ul> <p><b>Warning</b>                      The following troubleshooting flow chart contains fuel system diagnosis and repair procedures. Read following warnings before performing fuel system services:</p> <ul style="list-style-type: none"> <li>Fuel vapor is hazardous. It can easily ignite, causing serious injury and damage. Always keep sparks and flames away from fuel.</li> <li>Fuel line spills and leakage are dangerous. Fuel can ignite and cause serious injuries or death and damage. Fuel can also irritate skin and eyes. To prevent this, always complete "BEFORE REPAIR PROCEDURE" and "AFTER REPAIR PROCEDURE" described in this manual.                      (See 01-14-4 BEFORE REPAIR PROCEDURE.)                      (See 01-14-5 AFTER REPAIR PROCEDURE.)</li> </ul>

#### Diagnostic procedure

STEP	INSPECTION	RESULTS	ACTION
1	<ul style="list-style-type: none"> <li>Inspect for following:                             <ul style="list-style-type: none"> <li>External fuel shut off or accessory (kill switch, alarm etc.)</li> <li>Fuel quality: proper octane, contamination, winter/summer blend</li> <li>No air leakage from intake-air system</li> <li>Proper sealing of intake manifold and components attached to intake manifold: EGR valve, IAC valve</li> <li>Ignition wiring</li> <li>Electrical connections</li> <li>Fuses</li> <li>Smooth operation of throttle</li> </ul> </li> <li>Are all items okay?</li> </ul>	Yes	Go to next step.
		No	Service as necessary. Repeat Step 1.

## SYMPTOM TROUBLESHOOTING [ENGINE CONTROL SYSTEM (FS)]

STEP	INSPECTION	RESULTS	ACTION
2	<ul style="list-style-type: none"> <li>Connect WDS or equivalent to DLC-2.</li> <li>Turn ignition key to ON.</li> <li>Retrieve any DTC.</li> <li>Is "DTC" displayed?</li> </ul>	Yes	<b>DTC displayed:</b> <ul style="list-style-type: none"> <li>Go to appropriate DTC test.</li> </ul>
		No	<b>No DTC displayed:</b> <ul style="list-style-type: none"> <li>Go to next step.</li> </ul>
3	<ul style="list-style-type: none"> <li>Is engine overheating?</li> </ul>	Yes	Go to symptom troubleshooting "NO.17 COOLING SYSTEM CONCERNS - OVERHEATING [FS]."
		No	Go to next step.
4	<p><b>Note</b></p> <ul style="list-style-type: none"> <li>Following test is for engine running rough idle with A/C on concerns. If other symptoms exist, go to next step.</li> <li>Connect pressure gauge to A/C low and high pressure side lines.</li> <li>Start engine and run it at idle.</li> <li>Turn A/C switch on.</li> <li>Measure low side and high side pressures.</li> <li>Are reading pressures within specifications? (See 07-10-3 REFRIGERANT PRESSURE CHECK.)</li> </ul>	Yes	Go to next step.
		No	If A/C is always on, go to symptom troubleshooting "NO.24 A/C IS ALWAYS ON OR A/C COMPRESSOR RUNS CONTINUOUSLY [FS]." For other symptoms, inspect following: <ul style="list-style-type: none"> <li>Refrigerant charging amount</li> <li>Condenser fan operation</li> </ul>
5	<ul style="list-style-type: none"> <li>Start engine and run it at idle.</li> <li>Turn steering wheel right to left.</li> <li>Does engine running rough exist while turning steering wheel right to left?</li> </ul>	Yes	Inspect P/S pressure switch operation and wiring harness between P/S pressure switch connector and PCM connector terminal 31.
		No	Go to next step.
6	<ul style="list-style-type: none"> <li>Visually inspect CKP sensor and teeth of crankshaft pulley.</li> <li>Are CKP sensor and teeth of crankshaft pulley okay?</li> </ul>	Yes	Go to next step.
		No	Replace malfunctioning parts.
7	<ul style="list-style-type: none"> <li>Measure gap between CKP sensor and teeth of crankshaft pulley.</li> </ul> <p><b>Specification</b> <b>0.5—1.5 mm {0.020—0.059 in}</b></p> <ul style="list-style-type: none"> <li>Is gap within specification?</li> </ul>	Yes	Go to next step.
		No	Adjust CKP sensor.
8	<ul style="list-style-type: none"> <li>Inspect for cracks on high-tension leads.</li> <li>Are there any cracks on high-tension leads?</li> </ul>	Yes	Repair suspected high-tension leads.
		No	Go to next step.
9	<ul style="list-style-type: none"> <li>Inspect condition of spark plugs.</li> <li>Is spark plug wet, covered with carbon or grayish white?</li> </ul>	Yes	<b>Spark plug is wet or covered with carbon:</b> <ul style="list-style-type: none"> <li>Inspect for fuel leakage from injector.</li> </ul> <b>Spark plug is grayish white:</b> <ul style="list-style-type: none"> <li>Inspect for clogged fuel injector.</li> </ul>
		No	Install spark plugs on original cylinders. Go to next step.
10	<ul style="list-style-type: none"> <li>Start engine and disconnect IAC valve connector.</li> <li>Does rpm drop or engine stall?</li> </ul>	Yes	Go to next step.
		No	Inspect IAC valve and wiring harness.
11	<ul style="list-style-type: none"> <li>Install fuel pressure gauge between fuel filter and fuel distributor.</li> <li>Start engine and run it at idle.</li> <li>Measure fuel line pressure at idle.</li> <li>Is fuel line pressure correct at idle?</li> </ul> <p><b>Fuel line pressure</b> <b>210—250 kPa {2.1—2.6 kgf/cm<sup>2</sup>, 30—36 psi}</b></p>	Yes	Go to next step.
		No	<b>Zero or low:</b> <ul style="list-style-type: none"> <li>Inspect fuel pump circuit.</li> <li>Inspect for open fuel pump relief valve.</li> <li>Inspect for fuel leakage inside pressure regulator.</li> <li>Inspect for clogged main fuel line.</li> <li>Inspect PRC solenoid valve and related vacuum hose and harness.</li> </ul> <b>High:</b> <ul style="list-style-type: none"> <li>Inspect pressure regulator for high pressure cause.</li> <li>Inspect for clogged fuel return line.</li> </ul>
12	<ul style="list-style-type: none"> <li>Visually inspect for fuel leakage at fuel injector, O-ring, and fuel line.</li> <li>Service as necessary.</li> <li>Does fuel line pressure hold after ignition key is turned to LOCK? (See 01-14-28 Operation Inspection.)</li> </ul>	Yes	Go to next step.
		No	Inspect pressure regulator diaphragm condition. <ul style="list-style-type: none"> <li>If condition is okay, inspect fuel injector.</li> <li>If condition is not okay, replace pressure regulator.</li> </ul>

## SYMPTOM TROUBLESHOOTING [ENGINE CONTROL SYSTEM (FS)]

STEP	INSPECTION	RESULTS	ACTION
13	<ul style="list-style-type: none"> <li>• Connect WDS or equivalent to DLC-2.</li> <li>• Start engine and run it at idle.</li> <li>• Access LONG FT1 PID.</li> <li>• Measure LONG FT1 PID at idle.</li> <li>• Is PID value between -15% and +15%?</li> </ul>	Yes	Go to next step.
		No	LONG FT1 PID is out of specification. <b>Less than specification (too rich):</b> <ul style="list-style-type: none"> <li>• Inspect evaporative emission control system.</li> <li>• If system is okay, go to Step 15.</li> </ul> <b>Greater than specification (too lean):</b> <ul style="list-style-type: none"> <li>• Inspect for air leakage at intake-air system components.</li> <li>• If system okay, go to next step.</li> </ul>
14	<ul style="list-style-type: none"> <li>• Disconnect vacuum hose between purge solenoid valve and intake manifold from purge solenoid valve side.</li> <li>• Plug opening end of vacuum hose.</li> <li>• Start engine.</li> <li>• Does engine condition improve?</li> </ul>	Yes	Inspect if purge solenoid valve is stuck open mechanically. Inspect evaporative emission control system.
		No	Go to next step.
15	<ul style="list-style-type: none"> <li>• Remove and shake PCV valve.</li> <li>• Does PCV valve rattle?</li> </ul>	Yes	Go to next step.
		No	Replace PCV valve.
16	<ul style="list-style-type: none"> <li>• Is there any restriction in exhaust system?</li> </ul>	Yes	Inspect exhaust system.
		No	Go to next step.
17	<ul style="list-style-type: none"> <li>• Visually inspect CMP sensor and projections of camshaft pulley.</li> <li>• Are CMP sensor and projections of camshaft pulley okay?</li> </ul>	Yes	Go to next step.
		No	Replace malfunctioning parts.
18	<ul style="list-style-type: none"> <li>• Inspect engine condition while tapping EGR valve housing.</li> <li>• Does engine condition improve?</li> </ul>	Yes	Replace EGR valve.
		No	Go to next step.
19	<ul style="list-style-type: none"> <li>• Is engine compression correct?</li> </ul>	Yes	Inspect valve timing.
		No	Inspect for causes.
20	<ul style="list-style-type: none"> <li>• Verify test results.               <ul style="list-style-type: none"> <li>— If okay, return to diagnostic index to service any additional symptoms.</li> <li>— If malfunction remains, refer to related Service Bulletins and perform repair or diagnosis.                   <ul style="list-style-type: none"> <li>• If vehicle is repaired, troubleshooting completed.</li> <li>• If vehicle is not repaired or additional diagnostic information is not available, replace PCM.</li> </ul> </li> </ul> </li> </ul>		

01-03B

# SYMPTOM TROUBLESHOOTING [ENGINE CONTROL SYSTEM (FS)]

## NO.9 FAST IDLE/RUNS ON [FS]

A3U010318881W14

<b>9</b>	<b>Fast idle/runs on</b>
<b>DESCRIPTION</b>	<ul style="list-style-type: none"> <li>• Engine speed continues at fast idle after warm-up.</li> <li>• Engine runs after ignition key is turned to OFF.</li> </ul>
<b>POSSIBLE CAUSE</b>	<ul style="list-style-type: none"> <li>• ECT sensor malfunction</li> <li>• Air leakage from intake-air system</li> <li>• Throttle body malfunction</li> <li>• Accelerator cable free play misadjustment</li> <li>• Cruise actuator cable misadjustment</li> </ul>

### Diagnostic procedure

STEP	INSPECTION	RESULTS	ACTION
1	<ul style="list-style-type: none"> <li>• Connect WDS or equivalent to DLC-2.</li> <li>• Access ECT PID.</li> <li>• Start and warm-up engine to normal operating temperature.</li> <li>• Is ECT PID reading between <b>82—112°C {180—234°F}</b>?</li> </ul>	Yes	Go to next step.
		No	<b>ECT PID is higher than 112°C {234°F}:</b> <ul style="list-style-type: none"> <li>• Go to symptom troubleshooting “NO.17 COOLING SYSTEM CONCERNS — OVERHEATING [FS].”</li> </ul> <b>ECT PID is less than 82°C {180°F}:</b> <ul style="list-style-type: none"> <li>• Go to symptom troubleshooting “NO.18 COOLING SYSTEM CONCERNS - RUNS COLD [FS].”</li> </ul>
2	<ul style="list-style-type: none"> <li>• Connect WDS or equivalent to DLC-2.</li> <li>• Turn ignition key to ON.</li> <li>• Retrieve any DTC.</li> <li>• Is “DTC” displayed?</li> </ul>	Yes	<b>DTC displayed:</b> <ul style="list-style-type: none"> <li>• Go to appropriate DTC test.</li> </ul>
		No	<b>No DTC displayed:</b> <ul style="list-style-type: none"> <li>• Go to next step.</li> </ul>
3	<ul style="list-style-type: none"> <li>• Is there air leakage felt or heard at intake-air system components while racing engine to higher speed?</li> </ul>	Yes	Repair or replace parts as necessary.
		No	Inspect accelerator cable free play. (See 01-13B-17 ACCELERATOR CABLE INSPECTION [FS].)
4	<ul style="list-style-type: none"> <li>• Verify test results.                             <ul style="list-style-type: none"> <li>— If okay, return to diagnostic index to service any additional symptoms.</li> <li>— If malfunction remains, refer to related Service Bulletins and perform repair or diagnosis.                                     <ul style="list-style-type: none"> <li>• If vehicle is repaired, troubleshooting completed.</li> <li>• If vehicle is not repaired or additional diagnostic information is not available, replace PCM.</li> </ul> </li> </ul> </li> </ul>		

## NO.10 LOW IDLE/STALLS DURING DECELERATION [FS]

A3U010318881W15

<b>10</b>	<b>Low idle/stalls during deceleration</b>
<b>DESCRIPTION</b>	<ul style="list-style-type: none"> <li>• Engine stops unexpectedly at beginning of deceleration or recovery from deceleration.</li> </ul>
<b>POSSIBLE CAUSE</b>	<ul style="list-style-type: none"> <li>• Vacuum leakage</li> <li>• IAC valve malfunction</li> <li>• Air leakage from intake-air system</li> <li>• TP sensor or related circuit malfunction</li> <li>• MAF sensor or related circuit malfunction</li> <li>• Brake switch or related circuit malfunction</li> <li>• Neutral/clutch switch or related circuit malfunction (MTX)</li> </ul>

### Diagnostic procedure

STEP	INSPECTION	RESULTS	ACTION
1	<ul style="list-style-type: none"> <li>• Does engine idle rough?</li> </ul>	Yes	Go to symptom troubleshooting “NO.8 ENGINE RUNS ROUGH/ROLLING IDLE [FS].”
		No	Go to next step.
2	<ul style="list-style-type: none"> <li>• Inspect for following:                             <ul style="list-style-type: none"> <li>— Proper routing and no damage of vacuum lines</li> <li>— IAC valve is connected properly.</li> <li>— No air leakage from intake-air system</li> </ul> </li> <li>• Are all items okay?</li> </ul>	Yes	Go to next step.
		No	Service as necessary. Repeat Step 2.
3	<ul style="list-style-type: none"> <li>• Connect WDS or equivalent to DLC-2.</li> <li>• Turn ignition key to ON.</li> <li>• Retrieve any DTC.</li> <li>• Is “DTC” displayed?</li> </ul>	Yes	<b>No DTC displayed:</b> <ul style="list-style-type: none"> <li>• Go to next step.</li> </ul>
		No	<b>DTC displayed:</b> <ul style="list-style-type: none"> <li>• Go to appropriate DTC test.</li> </ul>

## SYMPTOM TROUBLESHOOTING [ENGINE CONTROL SYSTEM (FS)]

STEP	INSPECTION	RESULTS	ACTION
4	<ul style="list-style-type: none"> <li>• Does idle speed drop or stall when disconnecting IAC valve?</li> </ul>	Yes	Go to next step.
		No	Inspect following: <ul style="list-style-type: none"> <li>• Circuit from IAC valve to PCM connector terminal 54 or 83 for open and short</li> <li>• IAC valve for sticking</li> </ul> If okay, go to next step.
5	<ul style="list-style-type: none"> <li>• Disconnect vacuum hose between purge solenoid valve and intake manifold from purge solenoid valve side.</li> <li>• Plug opening end of vacuum hose.</li> <li>• Drive vehicle.</li> <li>• Does engine condition improve?</li> </ul>	Yes	Inspect evaporative emission control system.
		No	Go to next step.
6	<ul style="list-style-type: none"> <li>• Connect WDS or equivalent to DLC-2.</li> <li>• Access TP, MAF, VSS PIDs.</li> <li>• Monitor each PID while driving vehicle.</li> <li>• Are PIDs okay?</li> </ul>	Yes	Go to symptom troubleshooting "NO.29 INTERMITTENT CONCERNS [FS]."
		No	<b>TP PID:</b> Inspect TP sensor. <b>MAF PID:</b> Inspect MAF sensor. <b>VSS PID:</b> Inspect VSS.
7	<ul style="list-style-type: none"> <li>• Verify test results.                             <ul style="list-style-type: none"> <li>— If okay, return to diagnostic index to service any additional symptoms.</li> <li>— If malfunction remains, refer to related Service Bulletins and perform repair or diagnosis.                                     <ul style="list-style-type: none"> <li>• If vehicle is repaired, troubleshooting completed.</li> <li>• If vehicle is not repaired or additional diagnostic information is not available, replace PCM.</li> </ul> </li> </ul> </li> </ul>		

01-03B

## SYMPTOM TROUBLESHOOTING [ENGINE CONTROL SYSTEM (FS)]

### NO.11 ENGINE STALLS/QUITS, ENGINE RUNS ROUGH, MISSES, BUCK/JERK, HESITATION/STUMBLE, SURGES [FS]

A3U010318881W16

11	<p><b>Engine stalls/quits — Acceleration/cruise</b>  <b>Engine runs rough — Acceleration/cruise</b>  <b>Misses — Acceleration/cruise</b>  <b>Buck/jerk — Acceleration/cruise/deceleration</b>  <b>Hesitation/stumble — Acceleration</b>  <b>Surges — Acceleration/cruise</b></p>
<b>DESCRIPTION</b>	<ul style="list-style-type: none"> <li>Engine stops unexpectedly at beginning of acceleration or during acceleration.</li> <li>Engine stops unexpectedly while cruising.</li> <li>Engine speed fluctuates during acceleration or cruising.</li> <li>Engine misses during acceleration or cruising.</li> <li>Vehicle bucks/jerks during acceleration, cruising or deceleration.</li> <li>Momentary pause at beginning of acceleration or during acceleration</li> <li>Momentary minor irregularity in engine output</li> </ul>
<b>POSSIBLE CAUSE</b>	<ul style="list-style-type: none"> <li>A/C system improper operation</li> <li>Erratic signal or no signal from CMP sensor</li> <li>Air leakage from intake-air system parts</li> <li>Purge solenoid valve malfunction</li> <li>IAC valve improper operation</li> <li>EGR valve malfunction</li> <li>Erratic signal from CKP sensor</li> <li>Low engine compression</li> <li>Vacuum leakage</li> <li>Poor fuel quality</li> <li>Spark leakage from high-tension leads</li> <li>Air cleaner restriction</li> <li>PCV valve malfunction</li> <li>Improper valve timing due to jumping out of timing belt</li> <li>Restriction in exhaust system</li> <li>Intermittent open or short in fuel pump circuit</li> <li>Inadequate fuel pressure</li> <li>Fuel pump mechanical malfunction</li> <li>Fuel leakage from fuel injector</li> <li>Fuel injector clogging</li> <li>Intermittent open or short of MAF sensor, throttle position sensor and VSS</li> <li>ATX malfunction</li> <li>Clutch slippage</li> </ul> <p><b>Warning</b>  <b>The following troubleshooting flow chart contains fuel system diagnosis and repair procedures. Read following warnings before performing fuel system services:</b></p> <ul style="list-style-type: none"> <li><b>Fuel vapor is hazardous. It can easily ignite, causing serious injury and damage. Always keep sparks and flames away from fuel.</b></li> <li><b>Fuel line spills and leakage are dangerous. Fuel can ignite and cause serious injuries or death and damage. Fuel can also irritate skin and eyes. To prevent this, always complete "BEFORE REPAIR PROCEDURE" and "AFTER REPAIR PROCEDURE" described in this manual.</b></li> </ul> <p><b>(See 01-14-4 BEFORE REPAIR PROCEDURE.)</b>  <b>(See 01-14-5 AFTER REPAIR PROCEDURE.)</b></p>

#### Diagnostic procedure

STEP	INSPECTION	RESULTS	ACTION
1	<ul style="list-style-type: none"> <li>Inspect for following:                             <ul style="list-style-type: none"> <li>— Vacuum connection</li> <li>— Air cleaner element</li> <li>— No air leakage from intake-air system</li> <li>— No restriction of intake-air system</li> <li>— Proper sealing of intake manifold and components attached to intake manifold: EGR valve, IAC valve</li> <li>— Ignition wiring</li> <li>— Fuel quality: proper octane, contamination, winter/summer blend</li> <li>— Electrical connections</li> <li>— Smooth operation of throttle</li> </ul> </li> <li>Are all items okay?</li> </ul>	<p style="text-align: center;">Yes</p> <hr/> <p style="text-align: center;">No</p>	<p style="text-align: center;">Go to next step.</p> <hr/> <p style="text-align: center;">Service as necessary. Repeat Step 1.</p>

## SYMPTOM TROUBLESHOOTING [ENGINE CONTROL SYSTEM (FS)]

STEP	INSPECTION	RESULTS	ACTION
2	<ul style="list-style-type: none"> <li>Connect WDS or equivalent to DLC-2.</li> <li>Turn ignition key to ON.</li> <li>Retrieve any DTC.</li> <li>Is "DTC" displayed?</li> </ul>	Yes	<b>No DTC displayed:</b> <ul style="list-style-type: none"> <li>Go to next step.</li> </ul>
		No	<b>DTC displayed:</b> <ul style="list-style-type: none"> <li>Go to appropriate DTC test.</li> </ul>
3	<ul style="list-style-type: none"> <li>Is engine overheating?</li> </ul>	Yes	Go to symptom troubleshooting "NO.17 COOLING SYSTEM CONCERNS - OVERHEATING [FS]."
		No	Go to next step.
4	<ul style="list-style-type: none"> <li>Connect WDS or equivalent to DLC-2.</li> <li>Access RPM PID, MAF PID, TP PID, and VSS PID.</li> <li>Drive vehicle with monitoring PIDs.</li> <li>Are PIDs within specification?</li> </ul>	Yes	Go to next step.
		No	<b>RPM PID:</b> <ul style="list-style-type: none"> <li>Inspect CKP sensor and related wiring harness: vibration, intermittent open/short circuit.</li> </ul> <b>MAF PID:</b> <ul style="list-style-type: none"> <li>Inspect for open circuit of MAF sensor and related wiring harness intermittently.</li> </ul> <b>TP PID:</b> <ul style="list-style-type: none"> <li>Inspect if output signal from TP sensor changes smoothly.</li> </ul> <b>VSS PID:</b> <ul style="list-style-type: none"> <li>Inspect for open circuit of VSS and related wiring harness intermittently.</li> </ul>
5	<ul style="list-style-type: none"> <li>Visually inspect CKP sensor and teeth of crankshaft pulley.</li> <li>Are CKP sensor and teeth of crankshaft pulley okay?</li> </ul>	Yes	Go to next step.
		No	Replace malfunctioning parts.
6	<ul style="list-style-type: none"> <li>Measure gap between CKP sensor and teeth of crankshaft pulley.</li> </ul> <b>Gap</b> <b>0.5—1.5 mm {0.020—0.059 in}</b> <ul style="list-style-type: none"> <li>Is gap within specification?</li> </ul>	Yes	Go to next step.
		No	Adjust CKP sensor.
7	<ul style="list-style-type: none"> <li>Inspect condition of spark plugs.</li> <li>Is spark plug wet, covered with carbon or grayish white?</li> </ul>	Yes	<b>Spark plug is wet or covered with carbon:</b> <ul style="list-style-type: none"> <li>Inspect for fuel leakage from fuel injector.</li> </ul> <b>Spark plug is grayish white:</b> <ul style="list-style-type: none"> <li>Inspect for clogged fuel injector.</li> </ul>
		No	Install spark plugs on original cylinders. Go to next step.
8	<ul style="list-style-type: none"> <li>Remove and shake PCV valve.</li> <li>Does PCV valve rattle?</li> </ul>	Yes	Go to next step.
		No	Replace PCV valve.
9	<ul style="list-style-type: none"> <li>Verify that throttle lever is resting on throttle valve stop screw and/or throttle valve orifice plug.</li> <li>Is lever in correct position?</li> </ul>	Yes	Go to next step.
		No	Adjust as necessary.
10	<ul style="list-style-type: none"> <li>Are there any restrictions in the exhaust system?</li> </ul>	Yes	Inspect exhaust system.
		No	Go to next step.
11	<ul style="list-style-type: none"> <li>Install fuel pressure gauge between fuel filter and fuel distributor.</li> <li>Connect jumper wire between F/P terminal at DLC in engine compartment and GND.</li> <li>Turn ignition key to ON.</li> <li>Is fuel line pressure correct with ignition key at ON?</li> </ul> <b>Fuel line pressure</b> <b>270—310 kPa {2.7—3.2 kgf/cm<sup>2</sup>, 39—45 psi}</b>	Yes	Go to next step.
		No	<b>Zero or low:</b> <ul style="list-style-type: none"> <li>Inspect fuel pump circuit.</li> <li>Inspect for open fuel pump relief valve.</li> <li>Inspect for fuel leakage inside pressure regulator.</li> <li>Inspect for clogged main fuel line.</li> </ul> <b>High:</b> <ul style="list-style-type: none"> <li>Inspect pressure regulator for high pressure cause.</li> <li>Inspect for clogged fuel return line.</li> </ul>
12	<ul style="list-style-type: none"> <li>Visually inspect for fuel leakage at fuel injector, O-ring, and fuel line.</li> <li>Service as necessary.</li> <li>Does fuel line pressure hold after ignition key is turned to LOCK? (See 01-14-28 Operation Inspection.)</li> </ul>	Yes	Go to next step.
		No	Inspect pressure regulator diaphragm condition. If condition is okay, inspect fuel injector. If condition is not okay, replace pressure regulator.

01-03B



## SYMPTOM TROUBLESHOOTING [ENGINE CONTROL SYSTEM (FS)]

STEP	INSPECTION	RESULTS	ACTION
13	<p><b>Note</b></p> <ul style="list-style-type: none"> <li>The following test is for engine stalling with A/C on. If other symptoms exist, go to next step.</li> <li>Connect pressure gauge to A/C low and high pressure side lines.</li> <li>Turn A/C on and measure low side and high side pressures.</li> <li>Are pressures within specifications? (See 07-10-3 REFRIGERANT PRESSURE CHECK.)</li> </ul>	Yes	Go to next step.
		No	If A/C is always on, go to symptom troubleshooting "NO.24 A/C IS ALWAYS ON OR A/C COMPRESSOR RUNS CONTINUOUSLY [FS]." For other symptoms, inspect following: <ul style="list-style-type: none"> <li>Refrigerant charging amount</li> <li>Condenser fan operation</li> </ul>
14	<p><b>Note</b></p> <ul style="list-style-type: none"> <li>The following test is performed for symptom with cruise control on. If other symptoms exist, go to next step.</li> <li>Inspect cruise control system.</li> <li>Is cruise control system okay?</li> </ul>	Yes	Go to next step.
		No	Repair or replace malfunctioning parts.
15	<ul style="list-style-type: none"> <li>Disconnect vacuum hose between purge solenoid valve and intake manifold from purge solenoid valve side.</li> <li>Plug opening end of vacuum hose.</li> <li>Drive vehicle.</li> <li>Does engine condition improve?</li> </ul>	Yes	Inspect if purge solenoid valve is stuck open mechanically. Inspect evaporative emission control system.
		No	Go to next step.
16	<ul style="list-style-type: none"> <li>Visually inspect CMP sensor and projections of camshaft pulley.</li> <li>Are CMP sensor and projections of camshaft pulley okay?</li> </ul>	Yes	Go to next step.
		No	Replace malfunctioning parts.
17	<ul style="list-style-type: none"> <li>Inspect EGR valve.</li> <li>Is EGR valve okay?</li> </ul>	Yes	Go to next step.
		No	Replace malfunctioning parts.
18	<ul style="list-style-type: none"> <li>Is engine compression correct?</li> </ul>	Yes	Inspect following: <ul style="list-style-type: none"> <li>Valve timing</li> <li>Internal transaxle part (ATX)</li> <li>Clutch (MTX)</li> </ul>
		No	Inspect for cause.
19	<ul style="list-style-type: none"> <li>Verify test results.                             <ul style="list-style-type: none"> <li>If okay, return to diagnostic index to service any additional symptoms.</li> <li>If malfunction remains, refer to related Service Bulletins and perform repair or diagnosis.                                     <ul style="list-style-type: none"> <li>If vehicle is repaired, troubleshooting completed.</li> <li>If vehicle is not repaired or additional diagnostic information is not available, replace PCM.</li> </ul> </li> </ul> </li> </ul>		

# SYMPTOM TROUBLESHOOTING [ENGINE CONTROL SYSTEM (FS)]

## NO.12 LACK/LOSS OF POWER-ACCELERATION/CRUISE [FS]

A3U010318881W17

<b>12</b>	<b>Lack/loss of power — Acceleration/cruise</b>
<b>DESCRIPTION</b>	<ul style="list-style-type: none"> <li>• Performance is poor under load (e.g. power down when climbing hills).</li> </ul>
<b>POSSIBLE CAUSE</b>	<ul style="list-style-type: none"> <li>• Improper A/C system operation</li> <li>• Erratic signal or no signal from CMP sensor</li> <li>• Air leakage from intake-air system parts</li> <li>• VICS malfunction</li> <li>• Tumble swirl control system malfunction</li> <li>• Purge control solenoid malfunction</li> <li>• EGR valve malfunction</li> <li>• Brake dragging</li> <li>• Erratic signal from CKP sensor</li> <li>• Low engine compression</li> <li>• Vacuum leakage</li> <li>• Poor fuel quality</li> <li>• Spark leakage from high-tension leads</li> <li>• Air cleaner restriction</li> <li>• PCV valve malfunction</li> <li>• Improper valve timing due to jumping out of timing belt</li> <li>• Restriction in exhaust system</li> <li>• Intermittent open or short in fuel pump circuit</li> <li>• Inadequate fuel pressure</li> <li>• Fuel pump mechanical malfunction</li> <li>• Fuel leakage from fuel injector</li> <li>• Fuel injector clogging</li> <li>• Intermittent open or short of MAF sensor, TP sensor and VSS</li> <li>• ATX malfunction</li> <li>• Clutch slippage</li> </ul> <p><b>Warning</b>  <b>The following troubleshooting flow chart contains fuel system diagnosis and repair procedures. Read following warnings before performing fuel system services:</b></p> <ul style="list-style-type: none"> <li>• <b>Fuel vapor is hazardous. It can easily ignite, causing serious injury and damage. Always keep sparks and flames away from fuel.</b></li> <li>• <b>Fuel line spills and leakage are dangerous. Fuel can ignite and cause serious injuries or death and damage. Fuel can also irritate skin and eyes. To prevent this, always complete “BEFORE REPAIR PROCEDURE” and “AFTER REPAIR PROCEDURE” described in this manual.</b>                      (See 01–14–4 BEFORE REPAIR PROCEDURE.)                      (See 01–14–5 AFTER REPAIR PROCEDURE.)</li> </ul>

01–03B

### Diagnostic procedure

STEP	INSPECTION	RESULTS	ACTION
1	<ul style="list-style-type: none"> <li>• Inspect for following:                             <ul style="list-style-type: none"> <li>— Vacuum connection</li> <li>— Air cleaner element</li> <li>— No air leakage from intake-air system</li> <li>— No restriction of intake-air system</li> <li>— Proper sealing of intake manifold and components attached to intake manifold: EGR valve, IAC valve</li> <li>— Fuel quality: proper octane, contamination, winter/summer blend</li> </ul> </li> <li>• Are all items okay?</li> </ul>	Yes	Go to next step.
		No	Service as necessary. Repeat Step 1.
2	<ul style="list-style-type: none"> <li>• Connect WDS or equivalent to DLC-2.</li> <li>• Turn ignition key to ON.</li> <li>• Retrieve any DTC.</li> <li>• Is “DTC” displayed?</li> </ul>	Yes	<b>DTC displayed:</b> <ul style="list-style-type: none"> <li>• Go to appropriate DTC test.</li> </ul>
		No	<b>No DTC displayed:</b> <ul style="list-style-type: none"> <li>• Go to next step.</li> </ul>
3	<ul style="list-style-type: none"> <li>• Is engine overheating?</li> </ul>	Yes	Go to symptom troubleshooting “NO.17 COOLING SYSTEM CONCERNS - OVERHEATING [FS].”
		No	Go to next step.

## SYMPTOM TROUBLESHOOTING [ENGINE CONTROL SYSTEM (FS)]

STEP	INSPECTION	RESULTS	ACTION
4	<ul style="list-style-type: none"> <li>Connect WDS or equivalent to DLC-2.</li> <li>Access RPM PID, MAF PID, TP PID, and VSS PID.</li> <li>Drive vehicle while monitoring PIDs.</li> <li>Are PIDs within specification?</li> </ul>	Yes	Go to next step.
		No	<b>RPM PID:</b> <ul style="list-style-type: none"> <li>Inspect CKP sensor and related wiring harness for vibration and/or intermittent open/short circuit.</li> </ul> <b>MAF PID:</b> <ul style="list-style-type: none"> <li>Inspect for intermittent open circuit of MAF sensor and related wiring harness.</li> </ul> <b>TP PID:</b> <ul style="list-style-type: none"> <li>Inspect if TP sensor output increases smoothly.</li> </ul> <b>VSS PID:</b> <ul style="list-style-type: none"> <li>Inspect for intermittent open circuit of VSS and related wiring harness.</li> </ul>
5	<ul style="list-style-type: none"> <li>Visually inspect CKP sensor and teeth of crankshaft pulley.</li> <li>Are CKP sensor and teeth of crankshaft pulley okay?</li> </ul>	Yes	Go to next step.
		No	Replace malfunctioning parts.
6	<ul style="list-style-type: none"> <li>Measure gap between CKP sensor and teeth of crankshaft pulley.</li> </ul> <b>Gap</b> <b>0.5—1.5 mm {0.020—0.059 in}</b> <ul style="list-style-type: none"> <li>Is the gap within specification?</li> </ul>	Yes	Go to next step.
		No	Adjust CKP sensor.
7	<ul style="list-style-type: none"> <li>Inspect condition of spark plugs.</li> <li>Is spark plug wet, covered with carbon or grayish white?</li> </ul>	Yes	<b>Spark plug is wet or covered with carbon:</b> <ul style="list-style-type: none"> <li>Inspect for fuel leakage from fuel injector.</li> </ul> <b>Spark plug is grayish white:</b> <ul style="list-style-type: none"> <li>Inspect for clogged fuel injector.</li> </ul>
		No	Install spark plugs on original cylinders. Go to next step.
8	<ul style="list-style-type: none"> <li>Remove and shake PCV valve.</li> <li>Does PCV valve rattle?</li> </ul>	Yes	Go to next step.
		No	Replace PCV valve.
9	<ul style="list-style-type: none"> <li>Is there any restriction in exhaust system?</li> </ul>	Yes	Inspect exhaust system.
		No	Go to next step.
10	<ul style="list-style-type: none"> <li>Install fuel pressure gauge between fuel filter and fuel distributor.</li> <li>Connect jumper wire between F/P terminal at DLC in engine compartment and GND.</li> <li>Turn ignition key to ON.</li> <li>Is fuel line pressure correct with ignition key on?</li> </ul> <b>Fuel line pressure</b> <b>270—310 kPa {2.7—3.2 kgf/cm<sup>2</sup>, 39—45 psi}</b>	Yes	Go to next step.
		No	<b>Zero or low:</b> <ul style="list-style-type: none"> <li>Inspect fuel pump circuit.</li> <li>Inspect for open fuel pump relief valve.</li> <li>Inspect for fuel leakage inside pressure regulator.</li> <li>Inspect for clogged main fuel line.</li> </ul> <b>High:</b> <ul style="list-style-type: none"> <li>Inspect pressure regulator for high pressure cause.</li> <li>Inspect for clogged fuel return line.</li> </ul>
11	<ul style="list-style-type: none"> <li>Inspect for VICS operation. (See 01—03B—57 VICS Operation Inspection.)</li> <li>Does VICS work properly?</li> </ul>	Yes	Go to next step.
		No	Repair or replace malfunctioning parts.
12	<ul style="list-style-type: none"> <li>Inspect for tumble swirl control system operation. (See 01—03B—57 Variable Tumble Control System (VTCS) Inspection.)</li> <li>Does tumble swirl control system work properly?</li> </ul>	Yes	Go to next step.
		No	Repair or replace malfunctioning parts.
13	<b>Note</b> <ul style="list-style-type: none"> <li>Following test is for engine stalling with A/C on concern. If other symptoms exist, go to next step.</li> <li>Connect pressure gauge to A/C low and high side pressure lines.</li> <li>Turn A/C on and measure low side and high side pressures.</li> <li>Are the pressures within specifications? (See 07—10—3 REFRIGERANT PRESSURE CHECK.)</li> </ul>	Yes	Go to next step.
		No	If A/C is always on, go to symptom troubleshooting "NO.24 A/C IS ALWAYS ON OR A/C COMPRESSOR RUNS CONTINUOUSLY [FS]". For other symptoms, inspect following: <ul style="list-style-type: none"> <li>Refrigerant charging amount</li> <li>Condenser fan operation</li> </ul>

## SYMPTOM TROUBLESHOOTING [ENGINE CONTROL SYSTEM (FS)]

STEP	INSPECTION	RESULTS	ACTION
14	<ul style="list-style-type: none"> <li>Disconnect vacuum hose between purge solenoid valve and intake manifold from purge solenoid valve side.</li> <li>Plug opening end of vacuum hose.</li> <li>Drive vehicle.</li> <li>Does engine condition improve?</li> </ul>	Yes	Inspect if purge solenoid valve is stuck open mechanically. Inspect evaporative emission control system.
		No	Go to next step.
15	<ul style="list-style-type: none"> <li>Visually inspect CMP sensor and projections of camshaft pulley.</li> <li>Are CMP sensor and projections of camshaft pulley okay?</li> </ul>	Yes	Go to next step.
		No	Replace malfunctioning parts.
16	<ul style="list-style-type: none"> <li>Inspect EGR valve.</li> <li>Is EGR valve okay?</li> </ul>	Yes	Go to next step.
		No	Replace malfunctioning parts.
17	<ul style="list-style-type: none"> <li>Is engine compression correct?</li> </ul>	Yes	Inspect following: <ul style="list-style-type: none"> <li>Valve timing</li> <li>Internal transaxle components (ATX)</li> <li>Clutch (MTX)</li> <li>Brake system for dragging</li> </ul>
		No	Inspect for cause.
18	<ul style="list-style-type: none"> <li>Verify test results.                             <ul style="list-style-type: none"> <li>If okay, return to diagnostic index to service any additional symptoms.</li> <li>If malfunction remains, refer to related Service Bulletins and perform repair or diagnosis.                                     <ul style="list-style-type: none"> <li>If vehicle is repaired, troubleshooting completed.</li> <li>If vehicle is not repaired or additional diagnostic information is not available, replace PCM.</li> </ul> </li> </ul> </li> </ul>		

01-03B

### NO.13 KNOCKING/PINGING-ACCELERATION/CRUISE [FS]

A3U010318881W18

13	Knocking/pinging — Acceleration/cruise
DESCRIPTION	<ul style="list-style-type: none"> <li>Sound is produced when air/fuel mixture is ignited by something other than spark plug (e.g. hot spot in combustion chamber).</li> </ul>
POSSIBLE CAUSE	<ul style="list-style-type: none"> <li>Engine overheating due to cooling system malfunction</li> <li>ECT sensor malfunction</li> <li>IAT sensor malfunction</li> <li>Inadequate engine compression</li> <li>Inadequate fuel pressure</li> </ul> <p><b>Warning</b> The following troubleshooting flow chart contains fuel system diagnosis and repair procedures. Read following warnings before performing fuel system services:</p> <ul style="list-style-type: none"> <li>Fuel vapor is hazardous. It can easily ignite, causing serious injury and damage. Always keep sparks and flames away from fuel.</li> <li>Fuel line spills and leakage are dangerous. Fuel can ignite and cause serious injuries or death and damage. Fuel can also irritate skin and eyes. To prevent this, always complete "BEFORE REPAIR PROCEDURE" and "AFTER REPAIR PROCEDURE" described in this manual. (See 01-14-4 BEFORE REPAIR PROCEDURE.) (See 01-14-5 AFTER REPAIR PROCEDURE.)</li> </ul>

#### Diagnostic procedure

STEP	INSPECTION	RESULTS	ACTION
1	<ul style="list-style-type: none"> <li>Connect WDS or equivalent to DLC-2.</li> <li>Access ECT PID.</li> <li>Verify ECT PID is <b>less than 116°C {241°F}</b> during driving.</li> <li>Is ECT PID less than specification?</li> </ul>	Yes	Go to next step.
		No	Inspect cooling system for cause of overheating.
2	<ul style="list-style-type: none"> <li>Connect WDS or equivalent to DLC-2.</li> <li>Turn ignition key on.</li> <li>Retrieve any DTC.</li> <li>Is "DTC" displayed?</li> </ul>	Yes	<b>No DTC displayed:</b> <ul style="list-style-type: none"> <li>Go to next step.</li> </ul>
		No	<b>DTC displayed:</b> <ul style="list-style-type: none"> <li>Go to appropriate DTC test.</li> </ul>
3	<ul style="list-style-type: none"> <li>Is engine compression correct?</li> </ul>	Yes	Go to next step.
		No	Inspect for cause.

## SYMPTOM TROUBLESHOOTING [ENGINE CONTROL SYSTEM (FS)]

STEP	INSPECTION	RESULTS	ACTION
4	<ul style="list-style-type: none"> <li>Install fuel pressure gauge between fuel filter and fuel distributor.</li> <li>Start engine and run it at idle.</li> <li>Measure fuel line pressure at idle.</li> <li>Is fuel line pressure correct at idle?</li> </ul> <b>Fuel line pressure</b> <b>210—250 kPa {2.1—2.6 kgf/cm<sup>2</sup>, 39—45 psi}</b>	Yes	Go to next step.
		No	<b>Zero or low:</b> <ul style="list-style-type: none"> <li>Inspect fuel pump circuit.</li> <li>Inspect for open fuel pump relief valve.</li> <li>Inspect for fuel leakage inside pressure regulator.</li> <li>Inspect for clogged main fuel line.</li> </ul> <b>High:</b> <ul style="list-style-type: none"> <li>Inspect pressure regulator for high pressure cause.</li> <li>Inspect for clogged fuel return line.</li> </ul>
5	<ul style="list-style-type: none"> <li>Verify test results.                             <ul style="list-style-type: none"> <li>If okay, return to diagnostic index to service any additional symptoms.</li> <li>If malfunction remains, refer to related Service Bulletins and perform repair or diagnosis.                                     <ul style="list-style-type: none"> <li>If vehicle is repaired, troubleshooting completed.</li> <li>If vehicle is not repaired or additional diagnostic information is not available, replace PCM.</li> </ul> </li> </ul> </li> </ul>		

### NO.14 POOR FUEL ECONOMY [FS]

A3U010318881W19

14	Poor fuel economy
<b>DESCRIPTION</b>	<ul style="list-style-type: none"> <li>Fuel economy is unsatisfactory.</li> </ul>
<b>POSSIBLE CAUSE</b>	<ul style="list-style-type: none"> <li>Contaminated air cleaner element</li> <li>VICS malfunction</li> <li>Tumble swirl control system malfunction</li> <li>Engine cooling system malfunction</li> <li>Improper automatic transaxle fluid level (ATX)</li> <li>Weak spark</li> <li>Poor fuel quality</li> <li>Erratic or no signal from CMP sensor</li> <li>Improper coolant level</li> <li>Inadequate fuel pressure</li> <li>Spark plug malfunction</li> <li>PCV valve malfunction</li> <li>Brake dragging</li> <li>Improper valve timing due to jumping out of timing belt</li> <li>Contaminated MAF sensor</li> <li>Improper engine compression</li> <li>Exhaust system clogging</li> </ul> <p><b>Warning</b>  <b>The following troubleshooting flow chart contains fuel system diagnosis and repair procedures. Read following warnings before performing fuel system services:</b></p> <ul style="list-style-type: none"> <li><b>Fuel vapor is hazardous. It can easily ignite, causing serious injury and damage. Always keep sparks and flames away from fuel.</b></li> <li><b>Fuel line spills and leakage are dangerous. Fuel can ignite and cause serious injuries or death and damage. Fuel can also irritate skin and eyes. To prevent this, always complete "BEFORE REPAIR PROCEDURE" and "AFTER REPAIR PROCEDURE" described in this manual.</b></li> </ul> <p><b>(See 01-14-4 BEFORE REPAIR PROCEDURE.)</b>  <b>(See 01-14-5 AFTER REPAIR PROCEDURE.)</b></p>

### Diagnostic procedure

STEP	INSPECTION	RESULTS	ACTION
1	<ul style="list-style-type: none"> <li>Inspect for following:                             <ul style="list-style-type: none"> <li>Air cleaner element for contamination</li> <li>Automatic transaxle fluid level</li> <li>Fuel quality</li> <li>Coolant level</li> </ul> </li> <li>Are all items okay?</li> </ul>	Yes	Go to next step.
		No	Service as necessary. Repeat Step 1.
2	<ul style="list-style-type: none"> <li>Connect WDS or equivalent to DLC-2.</li> <li>Turn ignition key to ON.</li> <li>Retrieve any DTC.</li> <li>Is "DTC" displayed?</li> </ul>	Yes	<b>No DTC displayed:</b> <ul style="list-style-type: none"> <li>Go to next step.</li> </ul>
		No	<b>DTC displayed:</b> <ul style="list-style-type: none"> <li>Go to appropriate DTC test.</li> </ul>
3	<ul style="list-style-type: none"> <li>Access ECT PID.</li> <li>Drive vehicle while monitoring PID.</li> <li>Is PID within specification?</li> </ul>	Yes	Go to next step.
		No	Inspect for coolant leakage, cooling fan and condenser fan operations or thermostat operation.

## SYMPTOM TROUBLESHOOTING [ENGINE CONTROL SYSTEM (FS)]

STEP	INSPECTION	RESULTS	ACTION
4	<ul style="list-style-type: none"> <li>Is strong blue spark visible at each disconnected high-tension lead while cranking engine?</li> </ul>	Yes	Inspect for following: <ul style="list-style-type: none"> <li>Spark plugs malfunction</li> <li>CMP sensor is improperly installed.</li> <li>Trigger wheel damage on camshaft</li> <li>Open or short circuit on CMP sensor</li> <li>Open or short circuit between CMP sensor and PCM terminal 85 or 86</li> </ul> Repair or replace malfunctioning parts. If okay, go to next step.
		No	Inspect following: <ul style="list-style-type: none"> <li>High-tension leads</li> <li>Ignition coil and connector</li> </ul>
5	<ul style="list-style-type: none"> <li>Install fuel pressure gauge between fuel filter and fuel distributor.</li> <li>Start engine and run it at idle.</li> <li>Measure fuel line pressure at idle.</li> <li>Is fuel line pressure correct at idle?</li> </ul> <b>Fuel line pressure</b> <b>210—250 kPa {2.1—2.6 kgf/cm<sup>2</sup>, 30—36 psi}</b>	Yes	Go to next step.
		No	<b>Zero or low:</b> <ul style="list-style-type: none"> <li>Inspect fuel pump circuit.</li> <li>Inspect for open fuel pump relief valve.</li> <li>Inspect for fuel leakage inside pressure regulator.</li> <li>Inspect for clogged main fuel line.</li> </ul> <b>High:</b> <ul style="list-style-type: none"> <li>Inspect pressure regulator for high pressure cause.</li> <li>Inspect for clogged fuel return line.</li> </ul>
6	<ul style="list-style-type: none"> <li>Inspect VICS operation. (See 01-03B-57 VICS Operation Inspection.)</li> <li>Does VICS work properly?</li> </ul>	Yes	Go to next step.
		No	Repair or replace malfunctioning parts.
7	<ul style="list-style-type: none"> <li>Inspect tumble swirl control system operation. (See 01-03B-57 Variable Tumble Control System (VTCS) Inspection.)</li> <li>Does tumble swirl control system work properly?</li> </ul>	Yes	Go to next step.
		No	Repair or replace malfunctioning parts.
8	<ul style="list-style-type: none"> <li>Remove and shake PCV valve.</li> <li>Does PCV valve rattle?</li> </ul>	Yes	Go to next step.
		No	Replace PCV valve.
9	<ul style="list-style-type: none"> <li>Is there any restriction in exhaust system?</li> </ul>	Yes	Inspect exhaust system.
		No	Go to next step.
10	<ul style="list-style-type: none"> <li>Is brake system functioning properly?</li> </ul>	Yes	Go to next step.
		No	Inspect for cause.
11	<ul style="list-style-type: none"> <li>Inspect MAF sensor for contamination.</li> <li>Is there any contamination?</li> </ul>	Yes	Replace MAF sensor.
		No	Go to next step.
12	<ul style="list-style-type: none"> <li>Is engine compression correct?</li> </ul>	Yes	Inspect valve timing.
		No	Inspect for cause.
13	<ul style="list-style-type: none"> <li>Verify test results.                             <ul style="list-style-type: none"> <li>If okay, return to diagnostic index to service any additional symptoms.</li> <li>If malfunction remains, refer to related Service Bulletins and perform repair or diagnosis.                                     <ul style="list-style-type: none"> <li>If vehicle is repaired, troubleshooting completed.</li> <li>If vehicle is not repaired or additional diagnostic information is not available, replace PCM.</li> </ul> </li> </ul> </li> </ul>		

01-03B

# SYMPTOM TROUBLESHOOTING [ENGINE CONTROL SYSTEM (FS)]

## NO.15 EMISSION COMPLIANCE [FS]

A3U010318881W20

<b>15</b>	<b>Emission compliance</b>
<b>DESCRIPTION</b>	<ul style="list-style-type: none"> <li>• Fails emissions test</li> </ul>
<b>POSSIBLE CAUSE</b>	<ul style="list-style-type: none"> <li>• Vacuum lines leakage or blockage</li> <li>• Cooling system malfunction</li> <li>• Spark plug malfunction</li> <li>• Leakage from intake manifold</li> <li>• Erratic or no signal from CMP sensor</li> <li>• Inadequate fuel pressure</li> <li>• PCV valve malfunction or incorrect valve installation</li> <li>• EGR valve malfunction</li> <li>• Exhaust system clogging</li> <li>• Fuel tank ventilation system malfunction</li> <li>• Charcoal canister damage</li> <li>• Excessive carbon is built up in combustion chamber.</li> <li>• Improper engine compression</li> <li>• Improper valve timing</li> </ul> <p><b>Warning</b>  <b>The following troubleshooting flow chart contains fuel system diagnosis and repair procedures. Read following warnings before performing fuel system services:</b></p> <ul style="list-style-type: none"> <li>• <b>Fuel vapor is hazardous. It can easily ignite, causing serious injury and damage. Always keep sparks and flames away from fuel.</b></li> <li>• <b>Fuel line spills and leakage are dangerous. Fuel can ignite and cause serious injuries or death and damage. Fuel can also irritate skin and eyes. To prevent this, always complete "BEFORE REPAIR PROCEDURE" and "AFTER REPAIR PROCEDURE" described in this manual.</b>                      (See 01-14-4 BEFORE REPAIR PROCEDURE.)                      (See 01-14-5 AFTER REPAIR PROCEDURE.)</li> </ul>

### Diagnostic procedure

STEP	INSPECTION	RESULTS	ACTION
1	<ul style="list-style-type: none"> <li>• Inspect for following:                             <ul style="list-style-type: none"> <li>— Vacuum lines for leakage or blockage</li> <li>— Electrical connections</li> <li>— Proper maintenance schedule followed</li> <li>— Intake-air system and air cleaner element concerns: obstructions, leakage or dirtiness</li> </ul> </li> <li>• Are all items okay?</li> </ul>	Yes	Go to next step.
		No	Service as necessary. Repeat Step 1.
2	<ul style="list-style-type: none"> <li>• Connect WDS or equivalent to DLC-2.</li> <li>• Turn ignition key to ON.</li> <li>• Retrieve any DTC.</li> <li>• Is "DTC" displayed?</li> </ul>	Yes	<b>No DTC displayed:</b> <ul style="list-style-type: none"> <li>• Go to next step.</li> </ul>
		No	<b>DTC displayed:</b> <ul style="list-style-type: none"> <li>• Go to appropriate DTC test.</li> </ul>
3	<ul style="list-style-type: none"> <li>• Is any other drivability concern present?</li> </ul>	Yes	Go to appropriate symptom troubleshooting.
		No	Go to next step.
4	<ul style="list-style-type: none"> <li>• Connect WDS or equivalent to DLC-2.</li> <li>• Access ECT PID.</li> <li>• Warm up engine and run it at idle.</li> <li>• Verify ECT PID is correct.</li> <li>• Is ECT PID correct?</li> </ul>	Yes	Go to next step.
		No	Inspect for coolant leakage, cooling fan and condenser fan operation or thermostat operation.
5	<ul style="list-style-type: none"> <li>• Is strong blue spark visible at each disconnected high-tension lead while cranking engine?</li> </ul>	Yes	Inspect for following: <ul style="list-style-type: none"> <li>• Spark plugs malfunction</li> <li>• CMP sensor is improperly installed.</li> <li>• Damage of trigger wheel on camshaft</li> <li>• Open or short circuit on CMP sensor</li> <li>• Open or short circuit between CMP sensor and PCM terminal 85 or 86</li> </ul> Repair or replace malfunctioning parts. If okay, go to next step.
		No	Inspect following: <ul style="list-style-type: none"> <li>• High-tension leads</li> <li>• Ignition coil and connector</li> </ul>

## SYMPTOM TROUBLESHOOTING [ENGINE CONTROL SYSTEM (FS)]

STEP	INSPECTION	RESULTS	ACTION
6	<ul style="list-style-type: none"> <li>Install fuel pressure gauge between fuel filter and fuel distributor.</li> <li>Start engine and run it at idle.</li> <li>Measure fuel line pressure at idle.</li> <li>Is fuel line pressure correct at idle?</li> </ul> <b>Fuel line pressure</b> 210—250 kPa {2.1—2.6 kgf/cm <sup>2</sup> , 30—36 psi}	Yes	Go to next step.
		No	<b>Zero or low:</b> <ul style="list-style-type: none"> <li>Inspect fuel pump circuit.</li> <li>Inspect for open fuel pump relief valve.</li> <li>Inspect for fuel leakage inside pressure regulator.</li> <li>Inspect for clogged main fuel line.</li> </ul> <b>High:</b> <ul style="list-style-type: none"> <li>Inspect pressure regulator for high pressure cause.</li> <li>Inspect for clogged fuel return line.</li> </ul>
7	<ul style="list-style-type: none"> <li>Remove and shake PCV valve.</li> <li>Does PCV valve rattle?</li> </ul>	Yes	Go to next step.
		No	Replace PCV valve.
8	<ul style="list-style-type: none"> <li>Inspect for fuel saturation inside charcoal canister.</li> <li>Is excess amount of liquid fuel present in canister?</li> </ul>	Yes	Replace charcoal canister.
		No	Inspect fuel tank vent system. Then, go to next step.
9	<ul style="list-style-type: none"> <li>Is there any restriction in exhaust system?</li> </ul>	Yes	Inspect exhaust system.
		No	Inspect EGR valve.
10	<ul style="list-style-type: none"> <li>Verify test results.                             <ul style="list-style-type: none"> <li>If okay, return to diagnostic index to service any additional symptoms.</li> <li>If malfunction remains, refer to related Service Bulletins and perform repair or diagnosis.                                     <ul style="list-style-type: none"> <li>If vehicle is repaired, troubleshooting completed.</li> <li>If vehicle is not repaired or additional diagnostic information is not available, replace PCM.</li> </ul> </li> </ul> </li> </ul>		

01-03B

### NO.16 HIGH OIL CONSUMPTION/LEAKAGE [FS]

A3U010318881W21

<b>16</b>	<b>High oil consumption/leakage</b>
<b>DESCRIPTION</b>	<ul style="list-style-type: none"> <li>Oil consumption is excessive.</li> </ul>
<b>POSSIBLE CAUSE</b>	<ul style="list-style-type: none"> <li>PCV valve malfunction</li> <li>Improper dipstick</li> <li>Improper engine oil viscosity</li> <li>Engine internal parts malfunction</li> </ul>

#### Diagnostic procedure

STEP	INSPECTION	RESULTS	ACTION
1	<ul style="list-style-type: none"> <li>Remove and shake PCV valve.</li> <li>Does PCV valve rattle?</li> </ul>	Yes	Go to next step.
		No	Replace PCV valve.
2	<ul style="list-style-type: none"> <li>Inspect for following:                             <ul style="list-style-type: none"> <li>External leakage</li> <li>Proper dipstick</li> <li>Proper engine oil viscosity</li> </ul> </li> <li>Are all items okay?</li> </ul>	Yes	Inspect internal engine parts such as valves, valve guides, valve stem seals, cylinder head drain passage, and piston rings.
		No	Service as necessary. Repeat Step 2.
3	<ul style="list-style-type: none"> <li>Verify test results.                             <ul style="list-style-type: none"> <li>If okay, return to diagnostic index to service any additional symptoms.</li> <li>If malfunction remains, refer to related Service Bulletins and perform repair or diagnosis.                                     <ul style="list-style-type: none"> <li>If vehicle is repaired, troubleshooting completed.</li> <li>If vehicle is not repaired or additional diagnostic information is not available, replace PCM.</li> </ul> </li> </ul> </li> </ul>		



# SYMPTOM TROUBLESHOOTING [ENGINE CONTROL SYSTEM (FS)]

## NO.17 COOLING SYSTEM CONCERNS-OVERHEATING [FS]

A3U010318881W22

<b>17</b>	<b>Cooling system concerns — Overheating</b>
<b>DESCRIPTION</b>	<ul style="list-style-type: none"> <li>• Engine runs at higher than normal temperature/overheats.</li> </ul>
<b>POSSIBLE CAUSE</b>	<ul style="list-style-type: none"> <li>• Improper coolant level</li> <li>• Blown fuses</li> <li>• Coolant leakage</li> <li>• Excessive A/C system pressure</li> <li>• Improper water/anti-freeze mixture</li> <li>• Fans reverse rotation</li> <li>• Poor radiator condition</li> <li>• Thermostat malfunction</li> <li>• Radiator hoses damage</li> <li>• Condenser fan is inoperative.</li> <li>• Improper or damaged radiator cap</li> <li>• Cooling fan is inoperative.</li> <li>• Coolant overflow system malfunction</li> <li>• Improper tension of drive belt</li> <li>• Drive belt damage</li> </ul>

### Diagnostic procedure

STEP	INSPECTION	RESULTS	ACTION
1	<ul style="list-style-type: none"> <li>• Inspect for following:                             <ul style="list-style-type: none"> <li>— Engine coolant level</li> <li>— Coolant leakage</li> <li>— Water and anti-freeze mixture</li> <li>— Radiator condition</li> <li>— Collapsed or restricted radiator hoses</li> <li>— Radiator pressure cap</li> <li>— Overflow system</li> <li>— Fan rotational direction</li> <li>— Fuses</li> </ul> </li> <li>• Are all items okay?</li> </ul>	Yes	Go to next step.
		No	Service as necessary. Repeat Step 1.
2	<ul style="list-style-type: none"> <li>• Connect WDS or equivalent to DLC-2.</li> <li>• Turn ignition key to ON.</li> <li>• Retrieve any DTC.</li> <li>• Is "DTC" displayed?</li> </ul>	Yes	<b>DTC displayed:</b> <ul style="list-style-type: none"> <li>• Go to appropriate DTC test.</li> </ul>
		No	<b>No DTC displayed:</b> <ul style="list-style-type: none"> <li>• Go to next step.</li> </ul>
3	<ul style="list-style-type: none"> <li>• Start engine and run it at idle speed.</li> <li>• Turn A/C switch on.</li> <li>• Does A/C compressor engage?</li> </ul>	Yes	Go to next step.
		No	Inspect for following and repair or replace as necessary: <ul style="list-style-type: none"> <li>• Refrigerant charging amount</li> <li>• Open circuit between A/C relay and PCM terminal 96</li> <li>• Seized A/C magnetic clutch</li> <li>• A/C magnetic clutch malfunction</li> </ul> If all items are okay, inspect following: <ul style="list-style-type: none"> <li>• Refrigerant pressure switch operation</li> <li>• Evaporator temperature sensor and A/C amplifier</li> <li>• A/C switch is stuck open.</li> <li>• Open or short circuit between refrigerant pressure switch and PCM terminal 41</li> <li>• Open circuit of blower motor fan switch and resistor (if blower motor does not operate)</li> </ul>

## SYMPTOM TROUBLESHOOTING [ENGINE CONTROL SYSTEM (FS)]

STEP	INSPECTION	RESULTS	ACTION
4	<ul style="list-style-type: none"> <li>• Start engine and run it at idle speed.</li> <li>• Turn A/C switch on.</li> <li>• Do cooling fan and condenser fan operate?</li> </ul>	Yes	Go to next step.
		No	<p><b>Cooling fan motor does not operate:</b></p> <ul style="list-style-type: none"> <li>• Inspect for following:                             <ul style="list-style-type: none"> <li>— Cooling fan relay is stuck open.</li> <li>— Cooling fan motor malfunction</li> <li>— Cooling fan motor GND open</li> <li>— Open circuit between cooling fan motor and relay</li> <li>— Open circuit between cooling fan relay and PCM terminal 47</li> <li>— Open battery power circuit for cooling fan relay</li> </ul> </li> </ul> <p><b>Condenser fan motor does not operate:</b></p> <ul style="list-style-type: none"> <li>• Inspect for following:                             <ul style="list-style-type: none"> <li>— Condenser fan relay is stuck open.</li> <li>— Condenser fan motor malfunction</li> <li>— Condenser fan motor GND open</li> <li>— Open circuit between condenser fan motor and relay</li> <li>— Open circuit between condenser fan relay and PCM terminal 45</li> <li>— Open battery power circuit for condenser fan relay</li> </ul> </li> </ul>
5	<ul style="list-style-type: none"> <li>• Is drive belt okay?</li> </ul>	Yes	Go to next step.
		No	Replace drive belt.
6	<ul style="list-style-type: none"> <li>• Is there any leakage around heater unit in passenger compartment?</li> </ul>	Yes	Inspect and service heater for leakage.
		No	Go to next step.
7	<ul style="list-style-type: none"> <li>• Is there any leakage at coolant hoses and/or radiator?</li> </ul>	Yes	Replace malfunctioning part.
		No	Go to next step.
8	<ul style="list-style-type: none"> <li>• Cool down the engine.</li> <li>• Remove thermostat and inspect operation. (See 01-12-5 THERMOSTAT REMOVAL/INSTALLATION.) (See 01-12-7 THERMOSTAT INSPECTION.)</li> <li>• Is thermostat okay?</li> </ul>	Yes	Engine coolant temperature and thermostat are okay. Inspect engine block for leakage or blockage.
		No	<p>Access ECT PID on WDS or equivalent. Inspect for both ECT and temperature gauge readings.</p> <ul style="list-style-type: none"> <li>• If temperature gauge on instrument cluster indicates normal range but ECT is not same as temperature gauge reading, inspect ECT sensor.</li> <li>• If temperature gauge on instrument cluster indicates overheating but ECT is normal, inspect temperature gauge and heat gauge unit.</li> </ul>
9	<ul style="list-style-type: none"> <li>• Verify test results.                             <ul style="list-style-type: none"> <li>— If okay, return to diagnostic index to service any additional symptoms.</li> <li>— If malfunction remains, refer to related Service Bulletins and perform repair or diagnosis.                                     <ul style="list-style-type: none"> <li>• If vehicle is repaired, troubleshooting completed.</li> <li>• If vehicle is not repaired or additional diagnostic information is not available, replace PCM.</li> </ul> </li> </ul> </li> </ul>		

01-03B

# SYMPTOM TROUBLESHOOTING [ENGINE CONTROL SYSTEM (FS)]

## NO.18 COOLING SYSTEM CONCERNS-RUNS COLD [FS]

A3U010318881W23

<b>18</b>	<b>Cooling system concerns — Runs cold</b>
<b>DESCRIPTION</b>	<ul style="list-style-type: none"> <li>• Engine does not reach normal operating temperature.</li> </ul>
<b>POSSIBLE CAUSE</b>	<ul style="list-style-type: none"> <li>• Thermostat malfunction</li> <li>• Condenser fan system malfunction</li> <li>• Cooling fan system malfunction</li> </ul>

### Diagnostic procedure

STEP	INSPECTION	RESULTS	ACTION
1	<ul style="list-style-type: none"> <li>• Is customer complaint "Lack of passenger compartment heat" only?</li> </ul>	Yes	Inspect A/C and heater system.
		No	Go to next step.
2	<ul style="list-style-type: none"> <li>• Does engine speed continue at fast idle?</li> </ul>	Yes	Go to symptom troubleshooting "NO.9 FAST IDLE/RUNS ON [FS]."
		No	Go to next step.
3	<ul style="list-style-type: none"> <li>• Remove thermostat and inspect operation. (See 01-12-5 THERMOSTAT REMOVAL/INSTALLATION.) (See 01-12-7 THERMOSTAT INSPECTION.)</li> <li>• Is thermostat okay?</li> </ul>	Yes	Inspect cooling fan and condenser fan operation. <ul style="list-style-type: none"> <li>• If both or either fan operate abnormally, inspect for following:                             <ul style="list-style-type: none"> <li>— Cooling fan relay is stuck closed.</li> <li>— Condenser fan relay is stuck closed.</li> <li>— Short to GND between cooling fan relay and PCM terminal 47</li> <li>— Short to GND between condenser fan relay and PCM terminal 45</li> <li>— Circuit between cooling fan relay and fan motor shorts to battery supply line</li> <li>— Circuit between condenser fan relay and fan motor shorts to battery supply line</li> </ul> </li> </ul>
		No	Access ECT PID on WDS or equivalent. Inspect both ECT and temperature gauge on instrument cluster readings. <ul style="list-style-type: none"> <li>• If temperature gauge on instrument cluster indicates normal range but ECT is not same as temperature gauge reading, inspect ECT sensor.</li> <li>• If temperature gauge on instrument cluster indicates cold range but ECT is normal, inspect temperature gauge and heat gauge unit.</li> </ul>
4	<ul style="list-style-type: none"> <li>• Verify test results.                             <ul style="list-style-type: none"> <li>— If okay, return to diagnostic index to service any additional symptoms.</li> <li>— If malfunction remains, refer to related Service Bulletins and perform repair or diagnosis.                                     <ul style="list-style-type: none"> <li>• If vehicle is repaired, troubleshooting completed.</li> <li>• If vehicle is not repaired or additional diagnostic information is not available, replace PCM.</li> </ul> </li> </ul> </li> </ul>		

# SYMPTOM TROUBLESHOOTING [ENGINE CONTROL SYSTEM (FS)]

## NO.19 EXHAUST SMOKE [FS]

A3U010318881W24

<b>19</b>	<b>Exhaust smoke</b>
<b>DESCRIPTION</b>	<ul style="list-style-type: none"> <li>• Blue, black, or white smoke from exhaust system</li> </ul>
<b>POSSIBLE CAUSE</b>	<p><b>Blue smoke (Burning oil):</b></p> <ul style="list-style-type: none"> <li>• PCV valve malfunction</li> <li>• Engine internal oil leakage</li> </ul> <p><b>White smoke (Water in combustion):</b></p> <ul style="list-style-type: none"> <li>• Cooling system malfunction (coolant loss)</li> <li>• Engine internal coolant leakage</li> </ul> <p><b>Black smoke (Rich fuel mixture):</b></p> <ul style="list-style-type: none"> <li>• Air cleaner restriction</li> <li>• Intake-air system is collapsed or restricted.</li> <li>• Fuel return line is restricted.</li> <li>• Excessive fuel pressure</li> <li>• Improper engine compression</li> <li>• Injector fuel leakage</li> <li>• Ignition system malfunction</li> </ul> <p><b>Warning</b>  <b>The following troubleshooting flow chart contains fuel system diagnosis and repair procedures. Read following warnings before performing fuel system services:</b></p> <ul style="list-style-type: none"> <li>• <b>Fuel vapor is hazardous. It can easily ignite, causing serious injury and damage. Always keep sparks and flames away from fuel.</b></li> <li>• <b>Fuel line spills and leakage are dangerous. Fuel can ignite and cause serious injuries or death and damage. Fuel can also irritate skin and eyes. To prevent this, always complete “BEFORE REPAIR PROCEDURE” and “AFTER REPAIR PROCEDURE” described in this manual.</b>                      (See 01–14–4 BEFORE REPAIR PROCEDURE.)                      (See 01–14–5 AFTER REPAIR PROCEDURE.)</li> </ul>

01–03B

### Diagnostic procedure

STEP	INSPECTION	RESULTS	ACTION
1	<ul style="list-style-type: none"> <li>• What color is smoke coming from exhaust system?</li> </ul>	Blue	Burning oil is indicated. Go to next step.
		White	Water in combustion is indicated. Go to Step 3.
		Black	Rich fuel mixture is indicated. Go to Step 4.
2	<ul style="list-style-type: none"> <li>• Remove and shake PCV valve.</li> <li>• Does PCV valve rattle?</li> </ul>	Yes	Inspect for following: <ul style="list-style-type: none"> <li>• Damaged valve guide, stems or valve seals</li> <li>• Blocked oil drain passage in cylinder head</li> <li>• Piston rings for not seated, seized or worn</li> <li>• Damaged cylinder bore</li> </ul> If other drivability symptoms are present, return to diagnostic index to service any additional symptoms.
		No	Replace PCV valve.
3	<ul style="list-style-type: none"> <li>• Does cooling system hold pressure?</li> </ul>	Yes	Inspect for following: <ul style="list-style-type: none"> <li>• Cylinder head gasket leakage</li> <li>• Intake manifold gasket leakage</li> <li>• Engine block cracks or porosity</li> </ul> If other driveability symptoms are present, return to diagnostic index to service any additional symptoms.
		No	Inspect for cause.
4	<ul style="list-style-type: none"> <li>• Inspect for following:                             <ul style="list-style-type: none"> <li>— Air cleaner restriction</li> <li>— Collapsed or restricted intake-air system</li> <li>— Restricted fuel return line</li> </ul> </li> <li>• Are all items okay?</li> </ul>	Yes	Go to next step.
		No	Service as necessary. Repeat Step 4.
5	<ul style="list-style-type: none"> <li>• Connect WDS or equivalent to DLC-2.</li> <li>• Turn ignition key to ON.</li> <li>• Retrieve any DTC.</li> <li>• Is “DTC” displayed?</li> </ul>	Yes	<b>No DTC displayed:</b> <ul style="list-style-type: none"> <li>• Go to next step.</li> </ul>
		No	<b>DTC displayed:</b> <ul style="list-style-type: none"> <li>• Go to appropriate DTC test.</li> </ul>

## SYMPTOM TROUBLESHOOTING [ENGINE CONTROL SYSTEM (FS)]

STEP	INSPECTION	RESULTS	ACTION
6	<ul style="list-style-type: none"> <li>Install fuel pressure gauge between fuel filter and fuel distributor.</li> <li>Start engine and run it at idle.</li> <li>Measure fuel line pressure at idle.</li> <li>Is fuel line pressure correct at idle?</li> </ul> <b>Fuel line pressure</b> <b>210—250 kPa {2.1—2.6 kgf/cm<sup>2</sup>, 30—36 psi}</b>	Yes	Go to next step.
		No	<b>Zero or low:</b> <ul style="list-style-type: none"> <li>Inspect fuel pump circuit.</li> <li>Inspect for open fuel pump relief valve.</li> <li>Inspect for fuel leakage inside pressure regulator.</li> <li>Inspect for clogged main fuel line.</li> </ul> <b>High:</b> <ul style="list-style-type: none"> <li>Inspect pressure regulator for high pressure cause.</li> <li>Inspect for clogged fuel return line.</li> </ul>
7	<ul style="list-style-type: none"> <li>Is strong blue spark visible at each disconnected high-tension lead while cranking engine?</li> </ul>	Yes	Inspect spark plugs and CMP sensor.
		No	Inspect following: <ul style="list-style-type: none"> <li>High-tension leads</li> <li>Ignition coil and connector</li> </ul>
8	<ul style="list-style-type: none"> <li>Verify test results.               <ul style="list-style-type: none"> <li>— If okay, return to diagnostic index to service any additional symptoms.</li> <li>— If malfunction remains, refer to related Service Bulletins and perform repair or diagnosis.                   <ul style="list-style-type: none"> <li>If vehicle is repaired, troubleshooting completed.</li> <li>If vehicle is not repaired or additional diagnostic information is not available, replace PCM.</li> </ul> </li> </ul> </li> </ul>		

### NO.20 FUEL ODOR (IN ENGINE COMPARTMENT) [FS]

A3U010318881W25

20	Fuel odor (in engine compartment)
<b>DESCRIPTION</b>	<ul style="list-style-type: none"> <li>Gasoline fuel smell or visible leakage</li> </ul>
<b>POSSIBLE CAUSE</b>	<ul style="list-style-type: none"> <li>Excessive fuel pressure</li> <li>Purge solenoid valve malfunction</li> <li>Fuel tank vent system blockage</li> <li>Charcoal canister malfunction</li> </ul> <p><b>Warning</b>  <b>The following troubleshooting flow chart contains fuel system diagnosis and repair procedures. Read following warnings before performing fuel system services:</b></p> <ul style="list-style-type: none"> <li><b>Fuel vapor is hazardous. It can easily ignite, causing serious injury and damage. Always keep sparks and flames away from fuel.</b></li> <li><b>Fuel line spills and leakage are dangerous. Fuel can ignite and cause serious injuries or death and damage. Fuel can also irritate skin and eyes. To prevent this, always complete "BEFORE REPAIR PROCEDURE" and "AFTER REPAIR PROCEDURE" described in this manual.</b>  <b>(See 01-14-4 BEFORE REPAIR PROCEDURE.)</b>  <b>(See 01-14-5 AFTER REPAIR PROCEDURE.)</b></li> </ul>

#### Diagnostic procedure

STEP	INSPECTION	RESULTS	ACTION
1	<ul style="list-style-type: none"> <li>Visually inspect for fuel leakage at fuel injector, O-ring, and fuel line.</li> <li>Service as necessary.</li> <li>Is fuel line pressure held after ignition key is turned to LOCK? (See 01-14-28 Operation Inspection.)</li> </ul>	Yes	Go to next step.
		No	Inspect pressure regulator diaphragm condition. <ul style="list-style-type: none"> <li>If condition is okay, inspect fuel injector.</li> <li>If condition is not okay, replace pressure regulator.</li> </ul>
2	<ul style="list-style-type: none"> <li>Inspect for blockage/restriction or open between engine vacuum port and charcoal canister.</li> <li>Inspect for blockage in fuel tank vent system.</li> <li>Is fault indicated?</li> </ul>	Yes	Replace vacuum hose.
		No	Go to next step.
3	<ul style="list-style-type: none"> <li>Inspect purge solenoid valve. (See 01-16-12 PURGE SOLENOID VALVE INSPECTION.)</li> <li>Is solenoid operating properly?</li> </ul>	Yes	Go to next step.
		No	Replace purge solenoid valve.
4	<ul style="list-style-type: none"> <li>Connect WDS or equivalent to DLC-2.</li> <li>Turn ignition key to ON.</li> <li>Retrieve any DTC.</li> <li>Is "DTC" displayed?</li> </ul>	Yes	<b>No DTC displayed:</b> <ul style="list-style-type: none"> <li>Inspect charcoal canister for fuel saturation.               <ul style="list-style-type: none"> <li>— If excess amount of liquid fuel is present, replace charcoal canister.</li> </ul> </li> </ul>
		No	<b>DTC displayed:</b> <ul style="list-style-type: none"> <li>Go to appropriate DTC test.</li> </ul>

# SYMPTOM TROUBLESHOOTING [ENGINE CONTROL SYSTEM (FS)]

STEP	INSPECTION	RESULTS	ACTION
5	<ul style="list-style-type: none"> <li>• Verify test results.                             <ul style="list-style-type: none"> <li>— If okay, return to diagnostic index to service any additional symptoms.</li> <li>— If malfunction remains, refer to related Service Bulletins and perform repair or diagnosis.                                     <ul style="list-style-type: none"> <li>• If vehicle is repaired, troubleshooting completed.</li> <li>• If vehicle is not repaired or additional diagnostic information is not available, replace PCM.</li> </ul> </li> </ul> </li> </ul>		

## NO.21 ENGINE NOISE [FS]

A3U010318881W26

01-03B

21	Engine noise
<b>DESCRIPTION</b>	<ul style="list-style-type: none"> <li>• Engine noise from under hood or driveline</li> </ul>
<b>POSSIBLE CAUSE</b>	<p><b>Squeal, click or chirp noise:</b></p> <ul style="list-style-type: none"> <li>• Improper engine oil level</li> <li>• Improper drive belt tension</li> </ul> <p><b>Rattle sound noise:</b></p> <ul style="list-style-type: none"> <li>• Loose parts</li> </ul> <p><b>Hiss sound noise:</b></p> <ul style="list-style-type: none"> <li>• Vacuum leakage</li> <li>• Loose spark plug</li> <li>• Air leakage from intake-air system</li> </ul> <p><b>Rumble or grind noise:</b></p> <ul style="list-style-type: none"> <li>• Improper drive belt tension</li> </ul> <p><b>Rap or roar sound noise:</b></p> <ul style="list-style-type: none"> <li>• Exhaust system looseness</li> </ul> <p><b>Other noise:</b></p> <ul style="list-style-type: none"> <li>• Camshaft friction gear noise or MLA noise</li> </ul>

### Diagnostic procedure

STEP	INSPECTION	RESULTS	ACTION
1	<ul style="list-style-type: none"> <li>• Is squeal, click or chirp sound present?</li> </ul>	Yes	Inspect engine oil level or drive belts.
		No	Go to next step.
2	<ul style="list-style-type: none"> <li>• Is rumble or grind sound present?</li> </ul>	Yes	Inspect drive belts.
		No	Go to next step.
3	<ul style="list-style-type: none"> <li>• Is rattle sound present?</li> </ul>	Yes	Inspect location of rattle for loose parts.
		No	Go to next step.
4	<ul style="list-style-type: none"> <li>• Is hiss sound present?</li> </ul>	Yes	Inspect for following: <ul style="list-style-type: none"> <li>• Vacuum leakage</li> <li>• Spark plug looseness</li> <li>• Intake-air system leakage</li> </ul>
		No	Go to next step.
5	<ul style="list-style-type: none"> <li>• Is rap or roar sound present?</li> </ul>	Yes	Inspect exhaust system for loose parts.
		No	Go to next step.
6	<ul style="list-style-type: none"> <li>• Is knock sound present?</li> </ul>	Yes	Go to symptom troubleshooting "NO.13 KNOCKING/ PINGING — ACCELERATION/CRUISE [FS]."
		No	If noise comes from engine internal, inspect for friction gear or MLA noise.
7	<ul style="list-style-type: none"> <li>• Verify test results.                             <ul style="list-style-type: none"> <li>— If okay, return to diagnostic index to service any additional symptoms.</li> <li>— If malfunction remains, refer to related Service Bulletins and perform repair or diagnosis.                                     <ul style="list-style-type: none"> <li>• If vehicle is repaired, troubleshooting completed.</li> <li>• If vehicle is not repaired or additional diagnostic information is not available, replace PCM.</li> </ul> </li> </ul> </li> </ul>		

# SYMPTOM TROUBLESHOOTING [ENGINE CONTROL SYSTEM (FS)]

## NO.22 VIBRATION CONCERNS (ENGINE) [FS]

A3U010318881W27

<b>22</b>	<b>Vibration concerns (engine)</b>
<b>DESCRIPTION</b>	<ul style="list-style-type: none"> <li>Vibration from under hood or driveline</li> </ul>
<b>POSSIBLE CAUSE</b>	<ul style="list-style-type: none"> <li>Loose attaching bolts or worn parts</li> <li>Components malfunction such as worn parts</li> </ul>

### Diagnostic procedure

STEP	INSPECTION	RESULTS	ACTION
1	<ul style="list-style-type: none"> <li>Inspect following components for loose attaching bolts or worn parts:                             <ul style="list-style-type: none"> <li>Cooling fan</li> <li>Drive belt and pulleys</li> <li>Engine mounts</li> </ul> </li> <li>Are all items okay?</li> </ul>	Yes	Inspect following systems: <ul style="list-style-type: none"> <li>Wheels</li> <li>Automatic transaxle</li> <li>Driveline</li> <li>Suspension</li> </ul>
		No	Readjust or retighten engine mount installation position. Service as necessary for other parts.
2	<ul style="list-style-type: none"> <li>Verify test results.                             <ul style="list-style-type: none"> <li>If okay, return to diagnostic index to service any additional symptoms.</li> <li>If malfunction remains, refer to related Service Bulletins and perform repair or diagnosis.                                     <ul style="list-style-type: none"> <li>If vehicle is repaired, troubleshooting completed.</li> <li>If vehicle is not repaired or additional diagnostic information is not available, replace PCM.</li> </ul> </li> </ul> </li> </ul>		

## NO.23 A/C DOES NOT WORK SUFFICIENTLY [FS]

A3U010318881W28

<b>23</b>	<b>A/C does not work sufficiently</b>
<b>DESCRIPTION</b>	<ul style="list-style-type: none"> <li>A/C compressor magnetic clutch does not engage when A/C switch is turned on.</li> </ul>
<b>POSSIBLE CAUSE</b>	<ul style="list-style-type: none"> <li>Improper refrigerant charging amount</li> <li>Open A/C magnetic clutch</li> <li>Open circuit between A/C relay and A/C magnetic clutch</li> <li>Poor GND of A/C magnetic clutch</li> <li>Refrigerant pressure switch is stuck open.</li> <li>A/C relay is stuck open.</li> <li>Seized A/C compressor</li> <li>Open circuit between A/C switch and PCM through both refrigerant pressure switch and A/C amplifier</li> </ul>

### Diagnostic procedure

STEP	INSPECTION	RESULTS	ACTION
1	<ul style="list-style-type: none"> <li>Connect WDS or equivalent to DLC-2.</li> <li>Turn ignition key to ON.</li> <li>Retrieve any DTC.</li> <li>Is "DTC" displayed?</li> </ul>	Yes	<b>DTC displayed:</b> <ul style="list-style-type: none"> <li>Go to appropriate DTC test.</li> </ul>
		No	<b>No DTC displayed:</b> <ul style="list-style-type: none"> <li>Go to next step.</li> </ul>
2	<ul style="list-style-type: none"> <li>Disconnect A/C compressor connector.</li> <li>Start engine and turn A/C switch to ON.</li> <li>Is there correct voltage at terminal of A/C compressor magnetic clutch connector?</li> </ul> <p><b>Specification</b> <b>More than 10.5 V</b></p>	Yes	Inspect for GND condition of magnetic clutch on A/C compressor. If GND condition is okay, inspect for open circuit of magnetic clutch coil.
		No	Go to next step.
3	<ul style="list-style-type: none"> <li>Disconnect refrigerant pressure switch connector.</li> <li>Connect jumper wires between terminals of refrigerant pressure switch connector.</li> <li>Turn ignition key to ON.</li> <li>Turn A/C switch on and set blower fan at any speed.</li> <li>Does A/C work?</li> </ul>	Yes	Inspect refrigerant pressure switch operation. <ul style="list-style-type: none"> <li>If switch is okay, go to next step.</li> </ul>
		No	Inspect for following: <ul style="list-style-type: none"> <li>A/C switch is stuck open.</li> <li>Open circuit between refrigerant pressure switch and PCM terminal 41</li> <li>Open circuit of blower motor fan switch and resistor (if blower motor does not operate)</li> <li>Evaporator temperature sensor and A/C amplifier</li> </ul>
4	<ul style="list-style-type: none"> <li>Remove jumper wires from switch connector.</li> <li>Reconnect connector to refrigerant pressure switch.</li> <li>Start engine and turn A/C switch on.</li> <li>Does fan operate?</li> </ul>	Yes	Inspect for stuck open A/C relay. Replace as necessary.
		No	Inspect following and repair or replace as necessary: <ul style="list-style-type: none"> <li>Refrigerant charging amount</li> <li>A/C compressor for being seized</li> </ul>

## SYMPTOM TROUBLESHOOTING [ENGINE CONTROL SYSTEM (FS)]

STEP	INSPECTION	RESULTS	ACTION
5	<ul style="list-style-type: none"> <li>Verify test results.                             <ul style="list-style-type: none"> <li>If okay, return to diagnostic index to service any additional symptoms.</li> <li>If malfunction remains, refer to related Service Bulletins and perform repair or diagnosis.                                     <ul style="list-style-type: none"> <li>If vehicle is repaired, troubleshooting completed.</li> <li>If vehicle is not repaired or additional diagnostic information is not available, replace PCM.</li> </ul> </li> </ul> </li> </ul>		

### NO.24 A/C IS ALWAYS ON OR A/C COMPRESSOR RUNS CONTINUOUSLY [FS]

A3U010318881W29

01-03B

24	A/C is always on or A/C compressor runs continuously
DESCRIPTION	<ul style="list-style-type: none"> <li>A/C compressor magnetic clutch does not disengage.</li> </ul>
POSSIBLE CAUSE	<ul style="list-style-type: none"> <li>Stuck engagement</li> <li>A/C relay is stuck closed.</li> <li>Short to GND between A/C switch and PCM</li> <li>Short to GND circuit between A/C relay and PCM</li> <li>A/C relay to magnetic clutch circuit shorts to battery power</li> </ul>

#### Diagnostic procedure

STEP	INSPECTION	RESULTS	ACTION
1	<ul style="list-style-type: none"> <li>Connect WDS or equivalent to DLC-2.</li> <li>Turn ignition key to ON.</li> <li>Retrieve any DTC.</li> <li>Is "DTC" displayed?</li> </ul>	Yes	<b>DTC displayed:</b> <ul style="list-style-type: none"> <li>Go to appropriate DTC test.</li> </ul>
		No	<b>No DTC displayed:</b> <ul style="list-style-type: none"> <li>Go to next step.</li> </ul>
2	<ul style="list-style-type: none"> <li>Start engine and run it at idle.</li> <li>Turn A/C switch on.</li> <li>Remove A/C relay.</li> <li>Does A/C magnetic clutch disengage?</li> </ul>	Yes	Inspect for following: <ul style="list-style-type: none"> <li>A/C relay is stuck closed.</li> <li>Short to GND circuit between A/C relay and PCM terminal 96</li> </ul> If both items are okay, go to next step.
		No	Inspect if circuit between A/C relay and magnetic clutch shorts to battery power circuit. <ul style="list-style-type: none"> <li>If circuit is okay, inspect magnetic clutch stuck engagement or clearance.</li> </ul>
3	<ul style="list-style-type: none"> <li>Disconnect refrigerant pressure switch connector.</li> <li>Start engine and turn A/C switch on.</li> </ul> <p><b>Note</b></p> <ul style="list-style-type: none"> <li>A/C should not work when disconnecting connector. If A/C remains working, short to GND circuit may be present.</li> </ul> <ul style="list-style-type: none"> <li>Does A/C reading remain working?</li> </ul>	Yes	Inspect for short to GND circuit between refrigerant pressure switch and PCM terminal 41.
		No	Go to next step.
4	<ul style="list-style-type: none"> <li>Reconnect refrigerant pressure switch connector.</li> <li>Turn off A/C switch.</li> </ul> <p><b>Note</b></p> <ul style="list-style-type: none"> <li>A/C should not work when turning the A/C switch off. If A/C remains working, short to GND circuit may be present.</li> </ul> <ul style="list-style-type: none"> <li>Does A/C reading remain working?</li> </ul>	Yes	Inspect following: <ul style="list-style-type: none"> <li>Short to GND circuit between A/C switch and A/C amplifier</li> <li>Short to GND circuit between A/C amplifier and refrigerant pressure switch</li> </ul>
		No	Inspect if A/C switch is stuck closed.
5	<ul style="list-style-type: none"> <li>Verify test results.                             <ul style="list-style-type: none"> <li>If okay, return to diagnostic index to service any additional symptoms.</li> <li>If malfunction remains, refer to related Service Bulletins and perform repair or diagnosis.                                     <ul style="list-style-type: none"> <li>If vehicle is repaired, troubleshooting completed.</li> <li>If vehicle is not repaired or additional diagnostic information is not available, replace PCM.</li> </ul> </li> </ul> </li> </ul>		



## SYMPTOM TROUBLESHOOTING [ENGINE CONTROL SYSTEM (FS)]

### NO.25 A/C IS NOT CUT OFF UNDER WIDE OPEN THROTTLE CONDITIONS [FS]

A3U010318881W30

<b>25</b>	<b>A/C is not cut off under wide open throttle conditions</b>
<b>DESCRIPTION</b>	<ul style="list-style-type: none"> <li>A/C compressor magnetic clutch does not disengage under wide open throttle.</li> </ul>
<b>POSSIBLE CAUSE</b>	<ul style="list-style-type: none"> <li>TP sensor malfunction</li> <li>TP sensor misadjustment</li> <li>TP sensor not securely installed</li> </ul>

#### Diagnostic procedure

STEP	INSPECTION	RESULTS	ACTION
1	<ul style="list-style-type: none"> <li>Does A/C compressor disengage when A/C switch is turned off?</li> </ul>	Yes	Go to next step.
		No	Go to symptom troubleshooting "NO.24 A/C IS ALWAYS ON OR A/C COMPRESSOR RUNS CONTINUOUSLY [FS]."
2	<ul style="list-style-type: none"> <li>Connect WDS or equivalent to DLC-2.</li> <li>Turn ignition key to ON.</li> <li>Retrieve any DTC.</li> <li>Is "DTC" displayed?</li> </ul>	Yes	<b>DTC displayed:</b> <ul style="list-style-type: none"> <li>Go to appropriate DTC test.</li> </ul>
		No	<b>No DTC displayed:</b> <ul style="list-style-type: none"> <li>Inspect TP sensor for proper adjustment.</li> </ul>
3	<ul style="list-style-type: none"> <li>Verify test results.                             <ul style="list-style-type: none"> <li>If okay, return to diagnostic index to service any additional symptoms.</li> <li>If malfunction remains, refer to related Service Bulletins and perform repair or diagnosis.                                     <ul style="list-style-type: none"> <li>If vehicle is repaired, troubleshooting completed.</li> <li>If vehicle is not repaired or additional diagnostic information is not available, replace PCM.</li> </ul> </li> </ul> </li> </ul>		

### NO.26 EXHAUST SULPHUR SMELL [FS]

A3U010318881W31

<b>26</b>	<b>Exhaust sulphur smell</b>
<b>DESCRIPTION</b>	<ul style="list-style-type: none"> <li>Rotten egg smell (sulphur) from exhaust</li> </ul>
<b>POSSIBLE CAUSE</b>	<ul style="list-style-type: none"> <li>Electrical connectors are disconnected or connected poorly</li> <li>Charcoal canister malfunction</li> <li>Vacuum lines are disconnected or connected improperly.</li> <li>Improper fuel pressure</li> </ul> <p><b>Warning</b></p> <p>The following troubleshooting flow chart contains fuel system diagnosis and repair procedures. Read following warnings before performing fuel system services:</p> <ul style="list-style-type: none"> <li>Fuel vapor is hazardous. It can easily ignite, causing serious injury and damage. Always keep sparks and flames away from fuel.</li> <li>Fuel line spills and leakage are dangerous. Fuel can ignite and cause serious injuries or death and damage. Fuel can also irritate skin and eyes. To prevent this, always complete "BEFORE REPAIR PROCEDURE" and "AFTER REPAIR PROCEDURE" described in this manual.</li> </ul> <p>(See 01-14-4 BEFORE REPAIR PROCEDURE.) (See 01-14-5 AFTER REPAIR PROCEDURE.)</p>

#### Diagnostic procedure

STEP	INSPECTION	RESULTS	ACTION
1	<ul style="list-style-type: none"> <li>Are any driveability or exhaust smoke concerns present?</li> </ul>	Yes	Go to appropriate flow chart.
		No	Go to next step.
2	<ul style="list-style-type: none"> <li>Inspect following:                             <ul style="list-style-type: none"> <li>Electrical connections</li> <li>Vacuum lines</li> </ul> </li> <li>Are all items okay?</li> </ul>	Yes	Go to next step.
		No	Service as necessary. Repeat Step 2.
3	<ul style="list-style-type: none"> <li>Connect WDS or equivalent to DLC-2.</li> <li>Turn ignition key to ON.</li> <li>Retrieve any DTC.</li> <li>Is "DTC" displayed?</li> </ul>	Yes	<b>DTC displayed:</b> <ul style="list-style-type: none"> <li>Go to appropriate DTC test.</li> </ul>
		No	<b>No DTC displayed:</b> <ul style="list-style-type: none"> <li>Go to next step.</li> </ul>

## SYMPTOM TROUBLESHOOTING [ENGINE CONTROL SYSTEM (FS)]

STEP	INSPECTION	RESULTS	ACTION
4	<ul style="list-style-type: none"> <li>Install fuel pressure gauge between fuel filter and fuel distributor.</li> <li>Start engine and run it at idle.</li> <li>Is fuel line pressure correct at idle?</li> </ul> <b>Fuel line pressure</b> <b>210—250 kPa {2.1—2.6 kgf/cm<sup>2</sup>, 30—36 psi}</b>	Yes	Go to next step.
		No	<b>Zero or low:</b> <ul style="list-style-type: none"> <li>Inspect fuel pump circuit.</li> <li>Inspect for open fuel pump relief valve.</li> <li>Inspect for fuel leakage inside pressure regulator.</li> <li>Inspect for clogged main fuel line.</li> </ul> <b>High:</b> <ul style="list-style-type: none"> <li>Inspect pressure regulator for high pressure cause.</li> <li>Inspect for clogged fuel return line.</li> </ul>
5	<ul style="list-style-type: none"> <li>Inspect charcoal canister for fuel saturation.</li> <li>Is excess amount of liquid fuel present in canister?</li> </ul>	Yes	Replace charcoal canister.
		No	Inspect fuel tank vent system. <ul style="list-style-type: none"> <li>If fuel tank vent system is okay, since sulfur content can vary in different fuels, suggest trying a different brand.</li> <li>If fuel tank vent system is not okay, repair or replace malfunctioning parts.</li> </ul>
6	<ul style="list-style-type: none"> <li>Verify test results.               <ul style="list-style-type: none"> <li>If okay, return to diagnostic index to service any additional symptoms.</li> <li>If malfunction remains, refer to related Service Bulletins and perform repair or diagnosis.                   <ul style="list-style-type: none"> <li>If vehicle is repaired, troubleshooting completed.</li> <li>If vehicle is not repaired or additional diagnostic information is not available, replace PCM.</li> </ul> </li> </ul> </li> </ul>		

01-03B

### NO.27 FUEL REFILL CONCERNS [FS]

A3U010318881W32

27	Fuel refill concerns
<b>DESCRIPTION</b>	<ul style="list-style-type: none"> <li>Fuel tank does not fill smoothly.</li> </ul>
<b>POSSIBLE CAUSE</b>	<ul style="list-style-type: none"> <li>Clogged evaporative emission pipes</li> <li>Nonreturn valve malfunction</li> <li>Pressure control valve malfunction</li> <li>Improper use of fuel nozzle</li> <li>Inadequate fuel filling speed</li> </ul> <p><b>Warning</b>            The following troubleshooting flow chart contains fuel system diagnosis and repair procedures. Read following warnings before performing fuel system services:</p> <ul style="list-style-type: none"> <li>Fuel vapor is hazardous. It can easily ignite, causing serious injury and damage. Always keep sparks and flames away from fuel.</li> <li>Fuel line spills and leakage are dangerous. Fuel can ignite and cause serious injuries or death and damage. Fuel can also irritate skin and eyes. To prevent this, always complete "BEFORE REPAIR PROCEDURE" and "AFTER REPAIR PROCEDURE" described in this manual.              (See 01-14-4 BEFORE REPAIR PROCEDURE.)              (See 01-14-5 AFTER REPAIR PROCEDURE.)</li> </ul>

### Diagnostic procedure

STEP	INSPECTION	RESULTS	ACTION
1	<ul style="list-style-type: none"> <li>Retrieve DTCs.</li> <li>Are there any DTCs displayed?</li> </ul>	Yes	Go to appropriate DTC test.
		No	Go to next step.
2	<ul style="list-style-type: none"> <li>Remove fuel-filler pipe.</li> <li>Make sure nonreturn valve is installed properly.</li> <li>Inspect nonreturn valve operation.</li> <li>Is nonreturn valve okay?</li> </ul>	Yes	Inspect following: <ul style="list-style-type: none"> <li>Improper use of fuel nozzle</li> <li>Inadequate fuel filling speed</li> <li>Pressure control valve</li> </ul>
		No	<b>If nonreturn valve is installed improperly:</b> <ul style="list-style-type: none"> <li>Reinstall nonreturn valve to proper position.</li> </ul> <b>If nonreturn valve does not operate properly:</b> <ul style="list-style-type: none"> <li>Replace non return valve.</li> </ul>
3	<ul style="list-style-type: none"> <li>Verify test results.               <ul style="list-style-type: none"> <li>If okay, return to diagnostic index to service any additional symptoms.</li> <li>If malfunction remains, refer to related Service Bulletins and perform repair or diagnosis.                   <ul style="list-style-type: none"> <li>If vehicle is repaired, troubleshooting completed.</li> <li>If vehicle is not repaired or additional diagnostic information is not available, replace PCM.</li> </ul> </li> </ul> </li> </ul>		

# SYMPTOM TROUBLESHOOTING [ENGINE CONTROL SYSTEM (FS)]

## NO.28 FUEL FILLING SHUT OFF ISSUES [FS]

A3U010318881W33

<b>28</b>	<b>Fuel filling shut off issues</b>
<b>DESCRIPTION</b>	<ul style="list-style-type: none"> <li>Fuel does not shut off properly.</li> </ul>
<b>POSSIBLE CAUSE</b>	<ul style="list-style-type: none"> <li>Clogged evaporative emission pipes</li> <li>Nonreturn valve malfunction</li> <li>Fuel shut-off valve malfunction</li> <li>Fuel nozzle malfunction</li> <li>Fuel nozzle is not inserted correctly.</li> </ul> <p><b>Warning</b>  <b>The following troubleshooting flow chart contains fuel system diagnosis and repair procedures. Read following warnings before performing fuel system services:</b></p> <ul style="list-style-type: none"> <li><b>Fuel vapor is hazardous. It can easily ignite, causing serious injury and damage. Always keep sparks and flames away from fuel.</b></li> <li><b>Fuel line spills and leakage are dangerous. Fuel can ignite and cause serious injuries or death and damage. Fuel can also irritate skin and eyes. To prevent this, always complete “BEFORE REPAIR PROCEDURE” and “AFTER REPAIR PROCEDURE” described in this manual.</b>                      (See 01-14-4 BEFORE REPAIR PROCEDURE.)                      (See 01-14-5 AFTER REPAIR PROCEDURE.)</li> </ul>

### Diagnostic procedure

STEP	INSPECTION	RESULTS	ACTION
1	<ul style="list-style-type: none"> <li>Retrieve DTCs.</li> <li>Are there any DTCs displayed?</li> </ul>	Yes	Go to appropriate DTC test.
		No	Go to next step.
2	<ul style="list-style-type: none"> <li>Remove fuel-filler pipe.</li> <li>Make sure nonreturn valve is installed properly.</li> <li>Inspect nonreturn valve operation.</li> <li>Is nonreturn valve okay?</li> </ul>	Yes	Inspect for following: <ul style="list-style-type: none"> <li>Improper use of fuel nozzle</li> <li>Fuel nozzle is not inserted correctly.</li> <li>Inspect fuel shut-off valve</li> </ul>
		No	<b>If nonreturn valve installed improperly:</b> <ul style="list-style-type: none"> <li>Reinstall nonreturn valve to proper position.</li> </ul> <b>If nonreturn valve does not operate properly:</b> <ul style="list-style-type: none"> <li>Replace nonreturn valve.</li> </ul>
3	<ul style="list-style-type: none"> <li>Verify test results.                             <ul style="list-style-type: none"> <li>— If okay, return to diagnostic index to service any additional symptoms.</li> <li>— If malfunction remains, refer to related Service Bulletins and perform repair or diagnosis.                                     <ul style="list-style-type: none"> <li>If vehicle is repaired, troubleshooting completed.</li> <li>If vehicle is not repaired or additional diagnostic information is not available, replace PCM.</li> </ul> </li> </ul> </li> </ul>		

## NO.29 INTERMITTENT CONCERNS [FS]

A3U010318881W34

<b>29</b>	<b>Intermittent concerns</b>
<b>DESCRIPTION</b>	<ul style="list-style-type: none"> <li>Symptom occurs randomly and is difficult to diagnose.</li> </ul>

### Diagnostic procedure

STEP	INSPECTION	RESULTS	ACTION
1	<ul style="list-style-type: none"> <li>Talk to customer.</li> <li>Retrieve vehicle service history.</li> <li>Does vehicle have a number of previous repairs and components replaced for a certain symptom?</li> </ul>	Yes	Go to next step.
		No	Go to Symptom Index.
2	<ul style="list-style-type: none"> <li>Connect WDS or equivalent to DLC-2.</li> <li>If input is switch-type component, turn on manually.</li> <li>Turn ignition key to ON.</li> <li>Access PIDs for suspect component.</li> <li>Lightly tap on suspect component, wiggle and pull each wire/connector at suspect component or PCM.</li> <li>Are any PID values out of range, or do they suddenly change and go back into range?</li> </ul>	Yes	Inspect each wire for corrosion, bent or loose terminal crimps.
		No	Go to next step.

## SYMPTOM TROUBLESHOOTING [ENGINE CONTROL SYSTEM (FS)]

STEP	INSPECTION	RESULTS	ACTION
3	<ul style="list-style-type: none"> <li>Start engine.</li> <li>Lightly tap on suspect component, wiggle and pull each wire/connector at suspect component or PCM.</li> <li>Are any PID values out of range, or do they suddenly change and go back into range?</li> </ul>	Yes	Inspect each wire for corrosion, bent or loose terminal crimps.
		No	Go to next step.
4	<ul style="list-style-type: none"> <li>Start engine.</li> <li>Accurately spray water on suspect component wire, component or vacuum line related to possible fault area.</li> <li>Are any PID values out of range, or suddenly change and go back into range, or was there a noticeable engine misfire/stumble?</li> </ul>	Yes	<b>Fault occurred while spraying on component:</b> <ul style="list-style-type: none"> <li>Replace part and verify repair.</li> </ul> <b>Fault occurred while spraying wiring:</b> <ul style="list-style-type: none"> <li>Inspect each wire for corrosion, bent or loose terminals and poor wire terminal crimps.</li> </ul> <b>Fault occurred while spraying vacuum line:</b> <ul style="list-style-type: none"> <li>Repair vacuum hoses.</li> </ul>
		No	Inspect wire and connector at suspect component for corrosion, bent or loose terminals, poor wire terminal crimps and high tension of wire. Repair as necessary.

01-03B

### NO.30 REFERENCE VOLTAGE [FS]

A3U010318881W35

30	Reference voltage
DESCRIPTION	<ul style="list-style-type: none"> <li>Incorrect reference voltage</li> </ul>
POSSIBLE CAUSE	<ul style="list-style-type: none"> <li>Reference voltage circuit malfunction</li> </ul> <p><b>Note</b></p> <ul style="list-style-type: none"> <li>TP sensor, EGR boost sensor and fuel tank pressure sensor use reference voltage.</li> </ul>

### Diagnostic procedure

STEP	INSPECTION	RESULTS	ACTION
1	<ul style="list-style-type: none"> <li>Disconnect appropriate sensor connector when reference voltage circuit inspection failed.</li> <li>Turn ignition key to ON.</li> <li>Measure voltage between following appropriate sensor connector terminals:                             <ul style="list-style-type: none"> <li>Reference voltage terminal</li> <li>GND terminal</li> </ul> </li> <li>Is reference voltage <b>greater than 6.0 V</b>?</li> </ul>	Yes	Go to Step 13.
		No	Go to next step.
2	<ul style="list-style-type: none"> <li>Is voltage across battery terminals <b>greater than 10.5 V</b>?</li> </ul>	Yes	Go to next step.
		No	Inspect charging system.
3	<ul style="list-style-type: none"> <li>Turn ignition key to LOCK.</li> <li>Leave appropriate sensor connector disconnected.</li> <li>Measure voltage between battery positive terminal and GND (between PCM and appropriate sensor) circuit at appropriate sensor connector.</li> <li>Is voltage <b>greater than 10.5 V</b> and <b>within 1.0 V</b> of battery voltage?</li> </ul>	Yes	Go to next step.
		No	Go to Step 8.
4	<p><b>Note</b></p> <ul style="list-style-type: none"> <li>The purpose of this step is to determine if WDS or equivalent is communicating with PCM.</li> <li>Turn ignition key to ON.</li> <li>Attempt to access ECT PID.</li> <li>Can ECT PID be accessed?</li> </ul>	Yes	Go to Step 7.
		No	Go to next step.
5	<ul style="list-style-type: none"> <li>Turn ignition key to LOCK.</li> <li>Disconnect TP sensor, EGR boost sensor, FTP sensor and PCM connectors.</li> <li>Turn ignition key to ON.</li> <li>Measure voltage between PCM connector terminals 71/97 and 24/51/76/77/103.</li> <li>Is voltage <b>greater than 10.5 V</b>?</li> </ul>	Yes	Go to next step.
		No	Repair open circuit between PCM terminal 71/97 and main relay.

## SYMPTOM TROUBLESHOOTING [ENGINE CONTROL SYSTEM (FS)]

STEP	INSPECTION	RESULTS	ACTION
6	<ul style="list-style-type: none"> <li>• Leave TP sensor, EGR boost sensor, FTP sensor and PCM connectors disconnected.</li> <li>• Measure resistance between PCM connector terminals 90 and 24/51/76/77/103.</li> <li>• Is resistance <b>greater than 10,000 ohms</b>?</li> </ul>	Yes	Inspect for reference voltage at suspect sensor connector again. If malfunction remains, refer to related Service Bulletins and perform repair or diagnosis. <ul style="list-style-type: none"> <li>• If vehicle is repaired, troubleshooting completed.</li> <li>• If vehicle is not repaired or additional diagnostic information is not available, replace PCM and repeat Step 6.</li> </ul>
		No	Repair constant voltage circuit short to GND.
7	<ul style="list-style-type: none"> <li>• Turn ignition key to LOCK.</li> <li>• Leave TP sensor disconnected.</li> <li>• Disconnect PCM connector.</li> <li>• Measure resistance between PCM connector terminal 90 and constant voltage circuit at appropriate sensor connector.</li> <li>• Is resistance <b>less than 5.0 ohms</b>?</li> </ul>	Yes	Inspect for reference voltage at suspect sensor connector again. If malfunction remains, refer to related Service Bulletins and perform repair or diagnosis. <ul style="list-style-type: none"> <li>• If vehicle is repaired, troubleshooting completed.</li> <li>• If vehicle is not repaired or additional diagnostic information is not available, replace PCM and repeat Step 7.</li> </ul>
		No	Repair open constant voltage circuit.
8	<p><b>Note</b></p> <ul style="list-style-type: none"> <li>• The purpose of this step is to determine if WDS or equivalent is communicating with PCM.</li> <li>• Reconnect TP sensor connector.</li> <li>• Turn ignition key to ON.</li> <li>• Attempt to access ECT PID.</li> <li>• Can ECT PID be accessed?</li> </ul>	Yes	Go to next step.
		No	Go to Step 11.
9	<ul style="list-style-type: none"> <li>• Are DTCs present for two or more sensors connected to PCM terminal 91?</li> <li>• Sensor connected to PCM terminal 91:                             <ul style="list-style-type: none"> <li>— TP sensor (P0122, P0123, P1122, P1123)</li> <li>— EGR boost sensor (P0106, P0107, P0108)</li> <li>— FTP sensor (P0452, P0453)</li> <li>— ECT sensor (P0117, P0118, P0125)</li> <li>— IAT sensor (P0111, P0112, P0113)</li> <li>— HO2S (front) (P0130, P0134)</li> <li>— HO2S (rear) (P0138, P0140)</li> </ul> </li> </ul>	Yes	Go to next step.
		No	Repair open GND circuit to sensor where reference voltage circuit inspection failed.
10	<ul style="list-style-type: none"> <li>• Turn ignition key to LOCK.</li> <li>• Disconnect WDS or equivalent from DLC-2.</li> <li>• Disconnect PCM connector.</li> <li>• Measure resistance between GND circuit at appropriate sensor connector and PCM connector terminal 91.</li> <li>• Is resistance <b>less than 5.0 ohms</b>?</li> </ul>	Yes	Reconnect sensor connector. Go to appropriate DTC test.
		No	Repair open GND circuit.
11	<ul style="list-style-type: none"> <li>• Turn ignition key to LOCK.</li> <li>• Disconnect PCM connector.</li> <li>• Measure resistance between battery negative terminal and PCM terminals 24/51/76/77/103.</li> <li>• Is each resistance <b>less than 5.0 ohms</b>?</li> </ul>	Yes	Go to next step.
		No	Repair open GND circuit.
12	<ul style="list-style-type: none"> <li>• Turn ignition key to LOCK.</li> <li>• Measure resistance between GND circuit at following sensor connector and GND:                             <ul style="list-style-type: none"> <li>— TP sensor</li> <li>— EGR boost sensor</li> <li>— FTP sensor</li> <li>— ECT sensor</li> <li>— IAT sensor</li> <li>— HO2S sensor (front)</li> <li>— HO2S sensor (rear)</li> </ul> </li> <li>• Is each resistance <b>less than 5.0 ohms</b>?</li> </ul>	Yes	GND circuits are okay. Inspect for reference voltage at suspect sensor connector again. <ul style="list-style-type: none"> <li>• If malfunction remains, refer to related Service Bulletins and perform repair or diagnosis.                             <ul style="list-style-type: none"> <li>— If vehicle is repaired, troubleshooting completed.</li> <li>— If vehicle is not repaired or additional diagnostic information is not available, replace PCM and repeat Step 12.</li> </ul> </li> </ul>
		No	Inspect for open GND circuit.

## SYMPTOM TROUBLESHOOTING [ENGINE CONTROL SYSTEM (FS)]

STEP	INSPECTION	RESULTS	ACTION
13	<ul style="list-style-type: none"> <li>• Turn ignition key to LOCK.</li> <li>• Disconnect TP sensor, EGR boost sensor, fuel tank pressure sensor and PCM connectors.</li> <li>• Turn ignition key on.</li> <li>• Measure voltage between reference voltage circuit at TP sensor connector and battery negative terminal.</li> <li>• Is voltage <b>less than 0.5 V</b>?</li> </ul>	Yes	Inspect for reference voltage at suspect sensor connector again. <ul style="list-style-type: none"> <li>• If malfunction remains, refer to related Service Bulletins and perform repair or diagnosis.                             <ul style="list-style-type: none"> <li>— If vehicle is repaired, troubleshooting completed.</li> <li>— If vehicle is not repaired or additional diagnostic information is not available, replace PCM and repeat Step 13.</li> </ul> </li> </ul>
		No	Repair constant voltage circuit short to power in harness.

01-03B

### NO.31 SPARK PLUG CONDITION [FS]

A3U010318881W36

31	Spark plug condition
<b>DESCRIPTION</b>	<ul style="list-style-type: none"> <li>• Incorrect spark plug condition</li> </ul>
<b>POSSIBLE CAUSE</b>	<p><b>Note</b></p> <ul style="list-style-type: none"> <li>• Inspecting spark plugs condition can determine whether problem is related to a specific cylinder or possibly to all cylinders.</li> </ul> <p><b>Wet/carbon is stuck on specific plug:</b></p> <ul style="list-style-type: none"> <li>• Spark—Weak, not visible</li> <li>• Air/fuel mixture—Excessive fuel injection volume</li> <li>• Compression—No compression, low compression</li> <li>• Faulty spark plug</li> </ul> <p><b>Grayish white with specific plug:</b></p> <ul style="list-style-type: none"> <li>• Air/fuel mixture—Insufficient fuel injection volume</li> <li>• Faulty spark plug</li> </ul> <p><b>Wet/carbon is stuck on all plugs:</b></p> <ul style="list-style-type: none"> <li>• Spark—Weak</li> <li>• Air/fuel mixture—Too rich</li> <li>• Compression—Low compression</li> <li>• Clogging in intake/exhaust system</li> </ul> <p><b>Grayish white with all plugs:</b></p> <ul style="list-style-type: none"> <li>• Air/fuel mixture—Too lean</li> </ul> <p><b>Warning</b></p> <p>The following troubleshooting flow chart contains the fuel system diagnosis and repair procedures.</p> <p>Read the following warnings before performing the fuel system services:</p> <ul style="list-style-type: none"> <li>• Fuel vapor is hazardous. It can easily ignite, causing serious injury and damage. Always keep sparks and flames away from fuel.</li> <li>• Fuel line spills and leakage are dangerous. Fuel can ignite and cause serious injuries or death and damage. Fuel can also irritate skin and eyes. To prevent this, always complete “BEFORE REPAIR PROCEDURE” and “AFTER REPAIR PROCEDURE” described in this manual.</li> </ul> <p>(See 01-14-4 BEFORE REPAIR PROCEDURE.)                      (See 01-14-5 AFTER REPAIR PROCEDURE.)</p>

### Diagnostic procedure

STEP	INSPECTION	RESULTS	ACTION
1	<ul style="list-style-type: none"> <li>• Remove all spark plugs.</li> <li>• Inspect each spark plug.</li> <li>• Is condition of spark plugs okay?</li> </ul>	Yes	Troubleshooting completed.
		No	<p><b>Specific plug is wet or covered with carbon:</b></p> <ul style="list-style-type: none"> <li>• Go to next step.</li> </ul> <p><b>Specific plug looks grayish white:</b></p> <ul style="list-style-type: none"> <li>• Go to Step 7.</li> </ul> <p><b>All plugs are wet or covered with carbon:</b></p> <ul style="list-style-type: none"> <li>• Go to Step 9.</li> </ul> <p><b>All plugs look grayish white:</b></p> <ul style="list-style-type: none"> <li>• Go to Step 15.</li> </ul>
2	<ul style="list-style-type: none"> <li>• Are any of spark plug wet/covered with carbon from engine oil?</li> </ul>	Yes	Working up and down, inspect all areas related to oil.
		No	Go to next step.

## SYMPTOM TROUBLESHOOTING [ENGINE CONTROL SYSTEM (FS)]

STEP	INSPECTION	RESULTS	ACTION
3	<ul style="list-style-type: none"> <li>• Inspect spark plug for following.                             <ul style="list-style-type: none"> <li>— Cracked insulator</li> <li>— Heating value</li> <li>— Air gap</li> <li>— Worn electrode</li> </ul> </li> <li>• Are spark plugs okay?</li> </ul>	Yes	Go to next step.
		No	Replace spark plug.
4	<ul style="list-style-type: none"> <li>• Inspect compression pressure at suspected faulty cylinder.</li> <li>• Is compression pressure correct? (See 01–10B–8 COMPRESSION INSPECTION [FS].)</li> </ul>	Yes	Go to next step.
		No	Repair or replace malfunctioning part.
5	<ul style="list-style-type: none"> <li>• Install all spark plugs.</li> <li>• Carry out spark test at suspected faulty cylinder.</li> <li>• Is strong blue spark visible? (Compare with normal cylinder.)</li> </ul>	Yes	Go to next step.
		No	Repair or replace malfunctioning part.
6	<ul style="list-style-type: none"> <li>• Perform fuel line pressure inspection. (See 01–14–28 PRESSURE REGULATOR INSPECTION.)</li> <li>• Is fuel line pressure okay?</li> </ul>	Yes	Inspect fuel injector for following: <ul style="list-style-type: none"> <li>• Open or short in injector</li> <li>• Leakage</li> <li>• Injection volume</li> </ul>
		No	<b>Zero or low:</b> <ul style="list-style-type: none"> <li>• Inspect fuel pump circuit.</li> <li>• Inspect open for fuel pump relief valve.</li> <li>• Inspect for fuel leakage inside pressure regulator.</li> <li>• Inspect for clogged main fuel line.</li> <li>• Inspect pulsation damper.</li> </ul> <b>High:</b> <ul style="list-style-type: none"> <li>• Inspect pressure regulator for high pressure cause.</li> <li>• Inspect for clogged fuel return line.</li> </ul>
7	<ul style="list-style-type: none"> <li>• Inspect spark plugs for following.                             <ul style="list-style-type: none"> <li>— Heating value</li> <li>— Air gap</li> </ul> </li> <li>• Are they okay?</li> </ul>	Yes	Go to next step.
		No	Replace spark plug.
8	<ul style="list-style-type: none"> <li>• Remove suspected fuel injector.</li> <li>• Inspect following:                             <ul style="list-style-type: none"> <li>— Resistance (See 01–14–24 Resistance Inspection.)</li> <li>— Fuel injection volume (See 01–14–24 FUEL INJECTOR INSPECTION.)</li> </ul> </li> <li>• Are all above items okay?</li> </ul>	Yes	Inspect for open circuit between suspected fuel injector connector terminal and PCM connector following terminals: <ul style="list-style-type: none"> <li>• <b>For #1 cylinder:</b> 75</li> <li>• <b>For #2 cylinder:</b> 101</li> <li>• <b>For #3 cylinder:</b> 74</li> <li>• <b>For #4 cylinder:</b> 100</li> </ul>
		No	Replace fuel injector.
9	<ul style="list-style-type: none"> <li>• Is air cleaner element free of restrictions?</li> </ul>	Yes	Go to next step.
		No	Replace air cleaner element.
10	<ul style="list-style-type: none"> <li>• Carry out spark test.</li> <li>• Is strong blue spark visible at each cylinder?</li> </ul>	Yes	Go to next step.
		No	Repair or replace malfunctioning part.
11	<ul style="list-style-type: none"> <li>• Carry out fuel line pressure inspection</li> <li>• Is fuel line pressure correct? <b>Fuel line pressure</b> <b>260—310 kPa {2.6—3.2 kgf/cm<sup>2</sup>, 37—45 psi}</b></li> </ul>	Yes	Go to next step.
		No	<b>Zero or low:</b> <ul style="list-style-type: none"> <li>• Inspect fuel pump circuit.</li> <li>• Inspect open for fuel pump relief valve.</li> <li>• Inspect for fuel leakage inside pressure regulator.</li> <li>• Inspect for clogged main fuel line.</li> <li>• Inspect pulsation damper.</li> </ul> <b>High:</b> <ul style="list-style-type: none"> <li>• Inspect pressure regulator for high pressure cause.</li> <li>• Inspect for clogged fuel return line.</li> </ul>
12	<ul style="list-style-type: none"> <li>• Inspect following PIDs.                             <ul style="list-style-type: none"> <li>— ECT</li> <li>— O2S11</li> <li>— O2S12</li> <li>— MAF</li> </ul> </li> <li>• Are PIDs okay?</li> </ul>	Yes	Go to next step.
		No	Repair or replace malfunctioning part.
13	<ul style="list-style-type: none"> <li>• Inspect purge solenoid valve. (When the engine can be started)</li> <li>• Is purge solenoid valve okay?</li> </ul>	Yes	Go to next step.
		No	Repair or replace malfunctioning part.

## SYMPTOM TROUBLESHOOTING [ENGINE CONTROL SYSTEM (FS)]

STEP	INSPECTION	RESULTS	ACTION
14	<ul style="list-style-type: none"> <li>Carry out compression inspection.</li> <li>Is compression correct?</li> </ul>	Yes	Inspect for clogging in exhaust system.
		No	Repair or replace malfunctioning part.
15	<ul style="list-style-type: none"> <li>When engine cannot be started, inspect intake-air system for air leakage.</li> <li>When engine can be started, carry out intake manifold vacuum inspection.</li> <li>Is air sucked in from intake-air system?</li> </ul>	Yes	Repair or replace malfunctioning part.
		No	Go to next step.
16	<ul style="list-style-type: none"> <li>Carry out fuel line pressure inspection.</li> <li>Is fuel line pressure correct?</li> </ul> <b>Fuel line pressure</b> <b>260—310 kPa {2.6—3.2 kgf/cm<sup>2</sup>, 37—45 psi}</b>	Yes	Inspect following PIDs. <ul style="list-style-type: none"> <li>ECT</li> <li>O2S11</li> <li>O2S12</li> <li>MAF</li> </ul> Inspect PCM GND condition.
		No	<b>Zero or low:</b> <ul style="list-style-type: none"> <li>Inspect fuel pump circuit.</li> <li>Inspect open for fuel pump relief valve.</li> <li>Inspect for fuel leakage inside pressure regulator.</li> <li>Inspect for clogged main fuel line.</li> <li>Inspect pulsation damper.</li> </ul> <b>High:</b> <ul style="list-style-type: none"> <li>Inspect pressure regulator for high pressure cause.</li> <li>Inspect for clogged fuel return line.</li> </ul>
17	<ul style="list-style-type: none"> <li>Verify test results. <ul style="list-style-type: none"> <li>If okay, return to diagnostic index to service any additional symptoms.</li> <li>If malfunction remains, inspect related Service Bulletins and perform repair or diagnosis. <ul style="list-style-type: none"> <li>If vehicle is repaired, troubleshooting is completed.</li> <li>If vehicle is not repaired or additional diagnostic information is not available, replace PCM.</li> </ul> </li> </ul> </li> </ul>		

01-03B



# SYMPTOM TROUBLESHOOTING [ENGINE CONTROL SYSTEM (FS)]

A3U010318881W37

## ENGINE CONTROL SYSTEM OPERATION INSPECTION [FS]

### Evaporative System Leak Inspection Using Leak Tester

1. Perform the following **SST** (Evaporative Emission System Tester MZ254AT3641) self-test:

#### Note

- If the tester does not work correctly during self-test, refer to the tester operators manual for more detailed self test procedures.

- (1) Verify the gas cylinder valve is closed and the control valve located on the tester is in the TEST position. All tester displays should be off at this time.
- (2) Connect the long hose (part of **SST**) to the tester.
- (3) Connect the manifold assembly (part of **SST**) to the long hose as shown.
- (4) Open the gas cylinder valve and verify the gas cylinder regulator left gauge reads **10 to 12 psi** (preset at factory).
  - If not, refer to the tester operators manual to contact tester manufacturer.
- (5) Press the ON/OFF switch to turn on the **SST** and make sure the left display reads **0.0**.
- (6) Turn the control valve on the tester to the FILL position.
- (7) Verify the left display reading is within **13.9 to 14.0 inches** of water.
  - If not, adjust the pressure using the regulator knob located on the right side of the tester.
- (8) Turn the control valve to TEST position and press the START switch.
- (9) After the 2-minute countdown (left display) is completed, the right display shows the total pressure loss for that period. A **0.5 inch** of water loss is acceptable on the self-test.
  - If the loss is more than **0.5 inch** of water, do one or more self-test. If the failed test repeats, check for leak using the ultrasonic leak detector (part of **SST**).

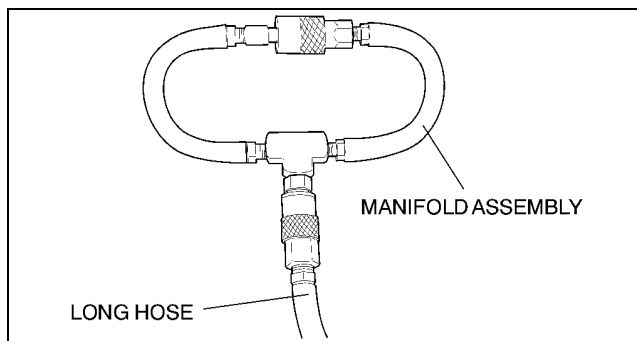

Y3U103WTO

2. Press the RESET switch to set the left display reading to **0.0**.
3. Connect the fuel cap test adapter (part of **SST**) to the manifold assembly and fuel-filler cap from the vehicle.
  - If the fuel-filler cap is not a genuine part, replace it.
4. Connect the threaded test adapter (part of **SST**) to the manifold assembly and fuel-filler neck.
5. Connect the WDS or equivalent to DLC-2.
6. Turn the ignition key to ON (engine OFF).
7. Close the canister drain cut valve (CDCV) using ON BOARD DEVICE CONTROL function.

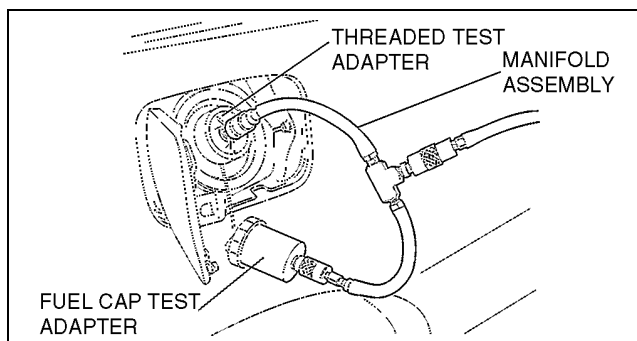

Y3U103WT1

#### Note

- The CDCV is closed for **10 minutes unless** the following any action is done:
  - The engine is started.
  - The ignition key is turned to OFF.
  - The fuel tank pressure sensor signal exceeds **6.43 kPa {48.3 mmHg, 1.9 inHg}**.

8. Turn the control valve to the FILL position.
9. Wait (**maximum 40 seconds**) until the left display reads **13.5 to 14 inches** of water.
  - If the reading is slightly below, adjust it using the regulator knob.
  - If the reading is far below, the EVAP system has large leak. Check for leak (using the ultrasonic leak detector if necessary) and repair.
10. Turn the control valve to the TEST position and press the START switch.
11. After the **2-minute** countdown (left display) is completed, check the test result (the failed/passed light on the tester).
  - If the green light turns on, the EVAP system is OK.
  - If the red light turns on, the EVAP system has leakage. Check for leak using the ultrasonic leak detector and repair.
12. Close the gas cylinder valve.
13. Turn the control valve to the FILL position.
14. Press the ON/OFF switch to turn off the tester.

## Evaporative System Leak Inspection Using Vacuum Pump

### Whole system inspection

1. Disconnect the vacuum hose between the purge solenoid valve and the catch tank from the purge solenoid valve.
2. Insert hose on the vacuum pump.
3. Connect WDS or equivalent to DLC-2.
4. Turn ignition key to ON (Engine OFF).
5. Close the canister drain cut valve (CDCV) using ON BOARD DEVICE CONTROL function.

### Note

- The CDCV is closed for **10 minutes unless** the following any action is done:
  - The engine is started.
  - The ignition key is turned to OFF.
  - The fuel tank pressure sensor signal **exceeds 6.43 kPa {48.3 mmHg, 1.9 inHg}**.

6. Apply 1.7 kPa vacuum and monitor FTP output voltage.
7. Verify that the voltage holds at the specified readings for a minimum of 2 minutes.
  - If the voltage does not hold, inspect the fuel tank pressure sensor.
  - If the fuel tank pressure sensor is okay, carry out the “Inspection from charcoal canister to fuel tank”.

### Inspection from charcoal canister to fuel tank

1. Inspect for loose and wrongly connected hoses between the charcoal canister and the fuel tank. (See 01–16–2 EMISSION SYSTEM LOCATION INDEX.)
2. Disconnect the vacuum hose between the charcoal canister and the fuel tank from the charcoal canister.
3. Insert hose on the vacuum pump.
4. Apply 1.7 kPa vacuum.
5. Verify that the vacuum holds at the specified readings for a minimum of 2 minutes.
  - If the vacuum does not hold, inspect the fuel tank, related vacuum hoses and fuel-filler cap.
  - If the the fuel tank, related vacuum hoses and fuel-filler cap are okay, carry out the “Inspection from charcoal canister to fuel tank”.

### Inspection from charcoal canister to purge solenoid valve

1. Inspect for loose and wrongly connected hoses between the charcoal canister and the purge solenoid valve. (See 01–16–2 EMISSION SYSTEM LOCATION INDEX.)
2. Disconnect the vacuum hose between the charcoal canister and the catch tank from the charcoal canister.
3. Insert hose on the vacuum pump.
4. Apply **3.3 kPa {25 mmHg, 1.0 inHg}** vacuum. Vacuum should hold at the specified readings for a minimum of 2 minutes.
  - If the vacuum does not hold, inspect the following:
    - Catch tank for plugging, damages and pinhole using vacuum pump
    - Purge solenoid valve (See 01–16–12 PURGE SOLENOID VALVE INSPECTION.)
    - Charcoal canister for damage and pinhole (See 01–16–9 CHARCOAL CANISTER INSPECTION.)
    - CDCV for damage and leakage (See 01–16–10 CANISTER DRAIN CUT VALVE (CDCV) INSPECTION .)
    - Detached, incorrectly installed or cracked hose from charcoal canister to CDCV

### Main Relay Operation Inspection

1. Verify that the main relay clicks when the ignition key is turned to ON and LOCK.
2. If there is no operation sound, inspect the following:
  - Main relay
  - Harness and connector between ignition key and main relay

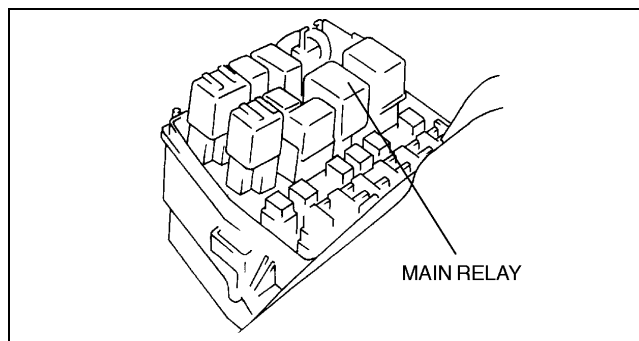

Y3U103WP6

# SYMPTOM TROUBLESHOOTING [ENGINE CONTROL SYSTEM (FS)]

## Intake Manifold Vacuum Inspection

1. Verify air intake hoses are installed properly.
2. Start the engine and run it at idle.
3. Measure the intake manifold vacuum using a vacuum gauge.
  - If not as specified, inspect the following:
    - Air suction at throttle body, intake manifold and PCV valve installation points
    - Fuel injector insulator
    - Accelerator cable free play
    - Engine compression (See 01–10B–8 COMPRESSION INSPECTION [FS].)

## Specification

More than 60 kPa {450 mmHg, 18 inHg}

## Note

- Air suction can be located by engine speed change when lubricant is sprayed on the area where suction is occurring.

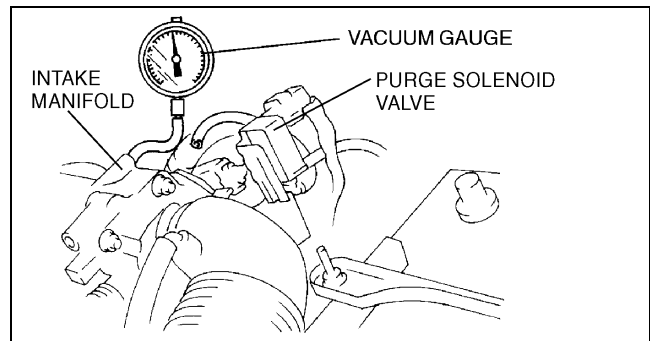

Y3U103WP7

## Idle Air Control (IAC) Inspection

### Engine coolant temperature compensation inspection

1. Connect the WDS or equivalent to DLC-2.
2. Select the following PIDs.
  - ECT
  - RPM
3. Verify that the engine is in cold condition, then start the engine.
4. Verify that the engine speed decreases as the engine warms up.
  - If the engine speed does not decrease or decreases slowly, carry out the following:
    - ECT sensor inspection
    - IAC valve inspection

### Load compensation inspection

1. Warm up the engine to normal operating temperature and run it at idle.
2. Connect the WDS or equivalent to DLC-2.
3. Select the following PID.
  - RPM
4. Turn the electrical loads on and verify that the engine speed is within the specification.
  - If not as specified, carry out the following:
    - A/C switch inspection
    - P/S pressure switch inspection
    - IAC valve inspection

### Engine speed (rpm)

Load condition	Idle-up speed (rpm)*
No load	650—750 (700±50)
Headlight switch is on.	
P/S on	700—800 (750±50)
A/C on	

\* : Neutral or P position

## Note

- Excludes temporary idle speed drop just after the loads are turned on.

# SYMPTOM TROUBLESHOOTING [ENGINE CONTROL SYSTEM (FS)]

01-03B

## VICS Operation Inspection

1. Start the engine.
2. Verify that the rod of VICS shutter valve actuator is pulled.
  - If the rod is pulled, proceed to next step .
  - If the rod is not pulled, inspect as follows.
    - Loose or damaged vacuum hose and vacuum chamber
    - Shutter valve actuator (See 01-13B-11 VARIABLE INERTIA CHARGING SYSTEM (VICS) SHUTTER VALVE ACTUATOR INSPECTION [FS].)
    - VICS solenoid valve inspection (See 01-13B-12 VARIABLE INERTIA CHARGING SYSTEM (VICS) SOLENOID VALVE INSPECTION [FS].)
3. Inspect the rod operation under the following condition.
  - If the rod operation is not as specified, inspect as follows.
    - Shutter valve actuator (See 01-13B-11 VARIABLE INERTIA CHARGING SYSTEM (VICS) SHUTTER VALVE ACTUATOR INSPECTION [FS].)
    - VICS solenoid valve inspection (See 01-13B-12 VARIABLE INERTIA CHARGING SYSTEM (VICS) SOLENOID VALVE INSPECTION [FS].)

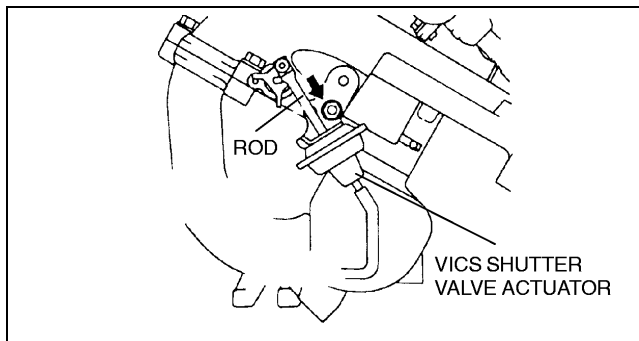

Y3U103WQ0

### Note

- The shutter valve actuator rod extends for five seconds after the engine is started.

## Rod operation

Engine speed (rpm)	5,250	
Shutter valve actuator	Not operate	Operate

## Variable Tumble Control System (VTCS) Inspection

1. Connect the WDS or equivalent to the DLC-2.
2. Access ECT PID.
3. Verify ECT PID is **65 °C {149 °F}** or less.
4. Start the engine.
5. Verify that the rod of tumble swirl control actuator is pulled.
  - If the rod is not pulled, inspect the following.
    - VTCS shutter valve actuator
    - VTCS delay valve
    - VTCS chamber
    - Vacuum hose
    - Tumble swirl control solenoid valve
    - Wiring harness and connectors (Main relay — VTCS solenoid valve — PCM terminal 73)
6. Access RPM PID.
7. Inspect the rod operation under the following condition.
  - If the rod operation is not as specified, inspect the following:
    - Tumble swirl control actuator
    - Vacuum delay valve
    - Vacuum chamber
    - Vacuum hose
    - VTCS solenoid valve
    - Wiring harness and connectors (Main relay — VTCS solenoid valve — PCM terminal 73)

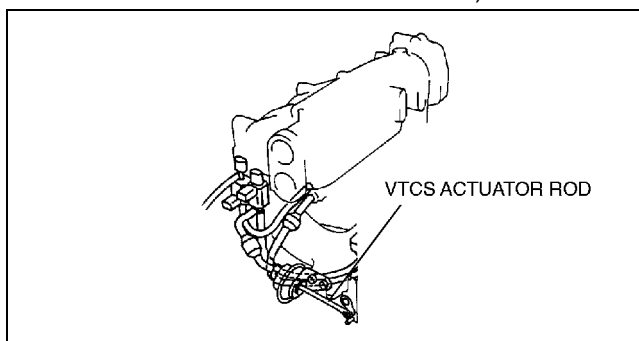

X3U101WEB

# SYMPTOM TROUBLESHOOTING [ENGINE CONTROL SYSTEM (FS)]

## Rod operation

Engine speed (RPM PID) (rpm)	Tumble swirl control actuator
3,000 or less	Operate
3,000 or more	Not operate

## Pressure Regulator Control Inspection

### Warning

- Fuel line spills and leakage are dangerous. Fuel can ignite and cause serious injuries or death. Fuel can also irritate skin and eyes.
- To prevent this, always complete the “Before Repair Procedure.” (See 01-14-4 BEFORE REPAIR PROCEDURE.)

1. Disconnect the negative battery cable.
2. Connect a fuel **SST** between the fuel filter and fuel distributor.
3. Connect the negative battery cable.
4. Measure the fuel line pressure under the following conditions.

### Specification

Condition	Fuel pressure (kPa {kgf/cm <sup>2</sup> , psi})		
	Idling	210—250 {2.1—2.6, 30—36}	210—250 {2.1—2.6, 30—36}
During 100 sec. of hot start	270—310 {2.7—3.2, 39—45}		
After 100 sec. of hot start	210—250 {2.1—2.6, 30—36}		
<b>Judgment</b>	Normal	Not Normal (Perform Inspection 1)	Not Normal (Perform Inspection 2)

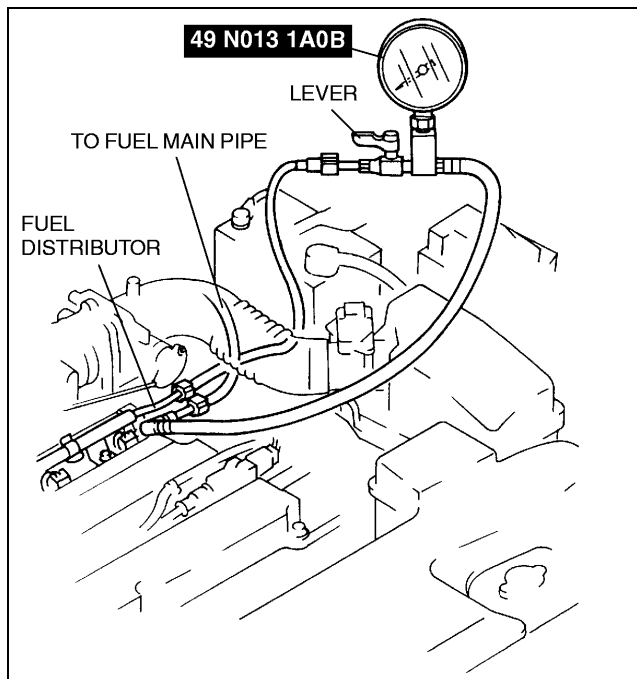

Y3U103WQ2

### Inspection 1

1. Inspect the following.
  - ECT, IAT, TP PIDs.
  - Pressure regulator
  - PRC solenoid valve

### Inspection 2

1. Inspect the following.
  - Loose or damage vacuum hose (Pressure regulator —PRC solenoid valve— intake manifold)
  - PRC solenoid valve

# SYMPTOM TROUBLESHOOTING [ENGINE CONTROL SYSTEM (FS)]

## Fuel Injector Operation Inspection

STEP	INSPECTION	RESULTS	ACTION
1	While cranking engine, inspect for fuel injector operation sound at each cylinder using a soundscope. Is operation sound heard?	Yes	Fuel injector operation is okay.
		No	<b>All cylinders no heard:</b> Go to next step. <b>Some cylinders no heard:</b> Go to Step 3.
2	Carry out main relay operation inspection. Is main relay operation normal?	Yes	Inspect following: <ul style="list-style-type: none"> <li>Fuel injector power system related wiring harness and connectors</li> <li>PCM connectors</li> <li>Fuel injector GND and related wiring harness and connectors</li> </ul>
		No	Repair or replace malfunctioning parts.
3	Change fuel injector connector of not operating fuel injector and operating fuel injector. Is operation sound heard?	Yes	Go to next step.
		No	Replace fuel injector.
4	Are wiring harness and connectors of not operating fuel injector okay? (Open or short)	Yes	Inspect PCM terminal voltage of fuel injector signal.
		No	Repair or replace malfunctioning parts.

01-03B

### Spark Test

1. Disconnect the fuel pump relay connector.
2. Verify that each high-tension lead and connector is connected properly.
3. Inspect the ignition system in the following procedure.

### Warning

- **High voltage in the ignition system can cause strong electrical shock which can result in serious injury. Avoid direct contact to the vehicle body during the following spark test.**

STEP	INSPECTION	RESULTS	ACTION
1	<ul style="list-style-type: none"> <li>Remove high-tension lead from spark plug.</li> <li>Hold high-tension lead with installed pliers <b>5—10 mm {0.20—0.39 in}</b> from GND.</li> <li>Crank engine and verify there is a strong blue spark. (Inspect each cylinder.)</li> </ul>	Yes	Ignition system is okay.
		No	<b>Some cylinders do not spark:</b> Go to next step. <b>All cylinders do not spark:</b> Go to Step 3.
2	<ul style="list-style-type: none"> <li>Is high-tension lead resistance correct?</li> </ul>	Yes	Inspect for cracks or damage of high-tension lead and ignition coil.
		No	Replace high-tension lead.
3	<ul style="list-style-type: none"> <li>Does PCM or ignition coil connector have poor connection?</li> </ul>	Yes	Repair or replace connector.
		No	Go to next step.
4	<ul style="list-style-type: none"> <li>Is ignition coil winding resistance okay?</li> </ul>	Yes	Go to next step.
		No	Replace ignition coil.
5	<ul style="list-style-type: none"> <li>Are following parts okay? <ul style="list-style-type: none"> <li>— CKP sensor and crankshaft pulley (also, inspect gap) <b>Specification</b> <b>0.5—1.5 mm {0.020—0.059 in}</b></li> <li>— PCM terminal 21/22 voltage <b>Specification</b> <b>Approx. 1.5 V</b></li> </ul> </li> </ul>	Yes	Inspect for open or short in wiring harness and connector of CKP sensor.
		No	Repair or replace malfunctioning parts.

**01-10A MECHANICAL [ZM]**

<b>MECHANICAL LOCATION INDEX [ZM].</b>	<b>01-10A-2</b>	Camshaft Installation Note . . . . .	<b>01-10A-16</b>
<b>DRIVE BELT INSPECTION [ZM] . . . . .</b>	<b>01-10A-3</b>	Camshaft Pulley Installation Note . . . . .	<b>01-10A-17</b>
Drive Belt Deflection Inspection . . . . .	<b>01-10A-3</b>	<b>FRONT OIL SEAL</b>	
Drive Belt Tension Inspection . . . . .	<b>01-10A-3</b>	<b>REPLACEMENT [ZM] . . . . .</b>	<b>01-10A-18</b>
<b>DRIVE BELT ADJUSTMENT [ZM] . . . . .</b>	<b>01-10A-4</b>	Front Oil Seal Removal Note . . . . .	<b>01-10A-18</b>
<b>VALVE CLEARANCE</b>		Front Oil Seal Installation Note . . . . .	<b>01-10A-18</b>
<b>INSPECTION [ZM] . . . . .</b>	<b>01-10A-5</b>	<b>REAR OIL SEAL REPLACEMENT [ZM] .</b>	<b>01-10A-19</b>
<b>VALVE CLEARANCE ADJUSTMENT</b>		Rear Oil Seal Removal Note . . . . .	<b>01-10A-19</b>
<b>[ZM] . . . . .</b>	<b>01-10A-6</b>	Rear Oil Seal Installation Note . . . . .	<b>01-10A-19</b>
<b>COMPRESSION INSPECTION [ZM]. . . . .</b>	<b>01-10A-8</b>	<b>ENGINE</b>	
Compression . . . . .	<b>01-10A-8</b>	<b>REMOVAL/INSTALLATION [ZM] . . . . .</b>	<b>01-10A-20</b>
<b>TIMING BELT</b>		No.1 Engine Mount Removal Note . . . . .	<b>01-10A-22</b>
<b>REMOVAL/INSTALLATION [ZM] . . . . .</b>	<b>01-10A-9</b>	Engine Mount Member	
No.3 Engine Mount Removal Note . . . . .	<b>01-10A-10</b>	Removal Note . . . . .	<b>01-10A-22</b>
Pulley Lock Bolt Removal/Installation		No.4 Engine Mount Removal Note . . . . .	<b>01-10A-22</b>
Note . . . . .	<b>01-10A-10</b>	No.3 Engine Mount Installation Note . . . . .	<b>01-10A-22</b>
Timing Belt Removal Note . . . . .	<b>01-10A-10</b>	No.4 Engine Mount Installation Note . . . . .	<b>01-10A-22</b>
Tensioner, Tensioner Spring		No.2 Engine Mount Installation Note . . . . .	<b>01-10A-23</b>
Installation Note . . . . .	<b>01-10A-11</b>	Engine Mount Member	
Timing Belt Installation Note . . . . .	<b>01-10A-11</b>	Installation Note . . . . .	<b>01-10A-23</b>
No.3 Engine Mount Installation Note . . . . .	<b>01-10A-13</b>	No.1 Engine Mount Installation Note . . . . .	<b>01-10A-23</b>
Cylinder Head Cover		<b>ENGINE</b>	
Installation Note . . . . .	<b>01-10A-13</b>	<b>DISASSEMBLY/ASSEMBLY [ZM]. . . . .</b>	<b>01-10A-24</b>
<b>CYLINDER HEAD GASKET</b>		<b>ENGINE TUNE-UP [ZM]. . . . .</b>	<b>01-10A-25</b>
<b>REPLACEMENT [ZM]. . . . .</b>	<b>01-10A-13</b>	Engine Tune-up Preparation . . . . .	<b>01-10A-25</b>
Camshaft Pulley Removal Note . . . . .	<b>01-10A-14</b>	Ignition Timing Inspection . . . . .	<b>01-10A-25</b>
Camshaft Removal Note . . . . .	<b>01-10A-15</b>	Idle Speed Adjustment . . . . .	<b>01-10A-26</b>
Cylinder Head Removal Note . . . . .	<b>01-10A-15</b>	Idle-up Speed Inspection . . . . .	<b>01-10A-26</b>
Cylinder Head Installation Note . . . . .	<b>01-10A-15</b>	Idle Mixture Inspection . . . . .	<b>01-10A-27</b>

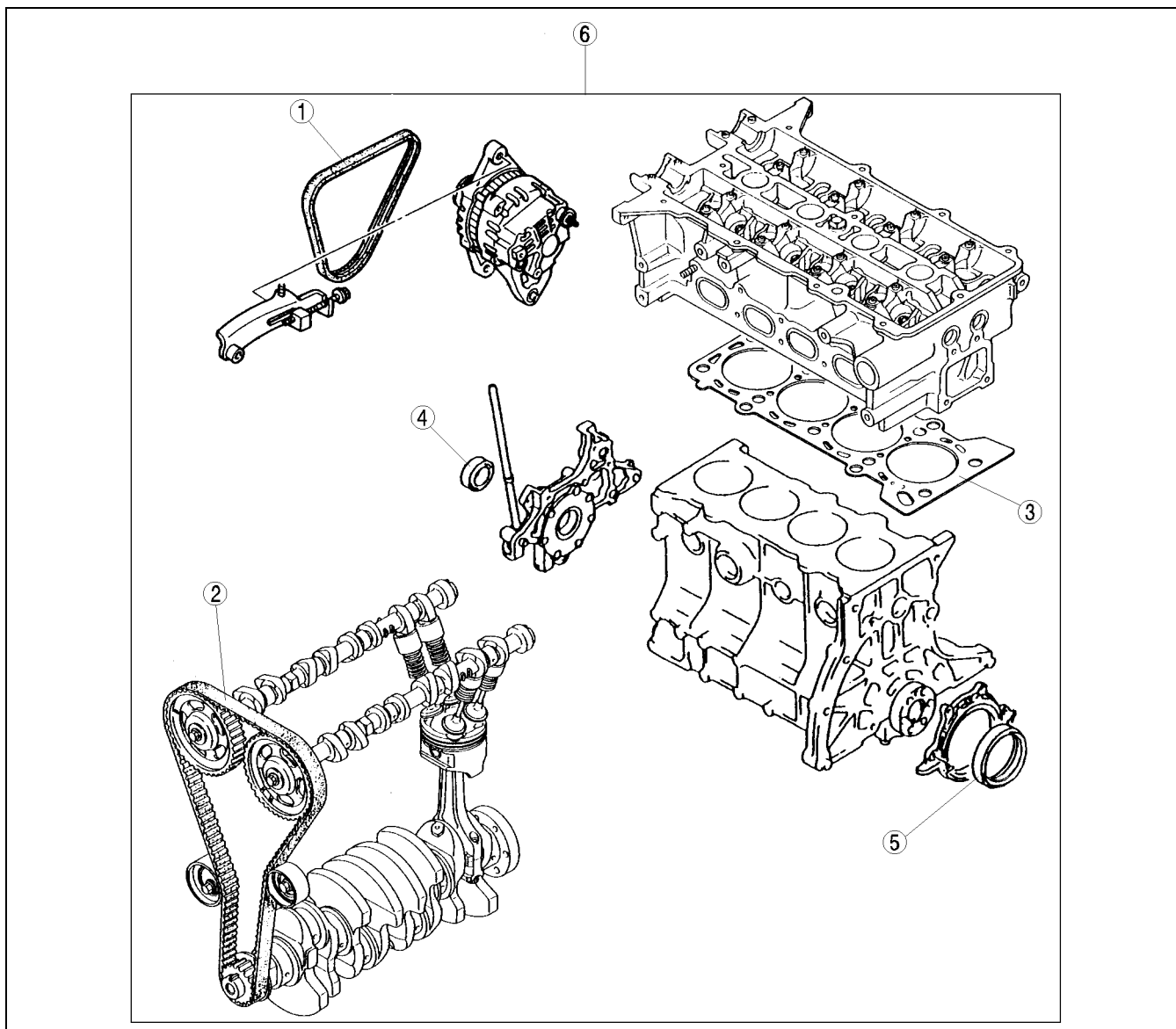

Z3U0110W101

1	Drive belt (See 01-10A-3 DRIVE BELT INSPECTION [ZM]) (See 01-10A-4 DRIVE BELT ADJUSTMENT [ZM])
2	Timing belt (See 01-10A-9 TIMING BELT REMOVAL/ INSTALLATION [ZM])
3	Cylinder head gasket (See 01-10A-13 CYLINDER HEAD GASKET REPLACEMENT [ZM])

4	Front oil seal (See 01-10A-18 FRONT OIL SEAL REPLACEMENT [ZM])
5	Rear oil seal (See 01-10A-19 REAR OIL SEAL REPLACEMENT [ZM])
6	Engine (See 01-10A-20 ENGINE REMOVAL/ INSTALLATION [ZM]) (See 01-10A-24 ENGINE DISASSEMBLY/ ASSEMBLY [ZM])



## DRIVE BELT INSPECTION [ZM]

A3U011015800W03

### Drive Belt Deflection Inspection

**Note**

- Inspect the drive belt deflection when the engine is cold, or **at least 30 min** after the engine has been stopped.

- Apply moderate pressure **98 N {10 kgf, 22 lbf}** midway between the specified pulleys.
  - If the deflection exceeds the limit, adjust it. (See 01-10A-4 DRIVE BELT ADJUSTMENT [ZM].)

**Deflection**

mm {in}

Drive belt	Limit
Generator	8.0 {0.31}
P/S, P/S+A/C	11.5 {0.45}

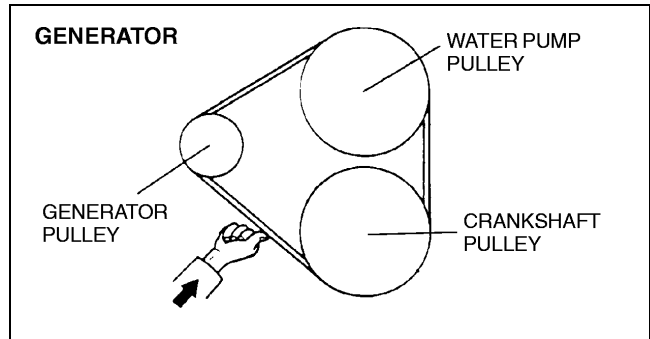

01-10A

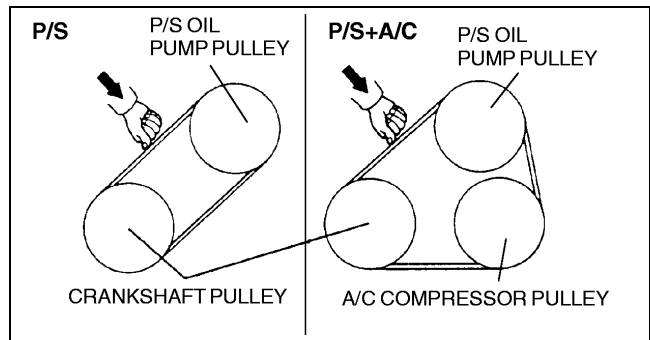

### Drive Belt Tension Inspection

**Note**

- Belt tension can be inspected in place of belt deflection. Inspect the drive belt tension when the engine is cold, or **at least 30 min** after the engine has been stopped.

- Using the **SST**, inspect the belt tension between any two pulleys.
  - If the tension exceeds the limit, adjust it. (See 01-10A-4 DRIVE BELT ADJUSTMENT [ZM].)

**Tension**

N {kgf, lbf}

Drive belt	Limit
Generator	340 {35, 77}
P/S, P/S+A/C	250{25, 55}

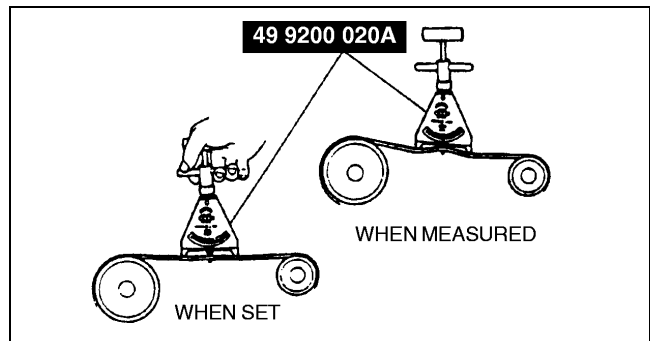

# MECHANICAL [ZM]

## DRIVE BELT ADJUSTMENT [ZM]

A3U011015800W04

1. Loosen mounting bolt A, B, and C.

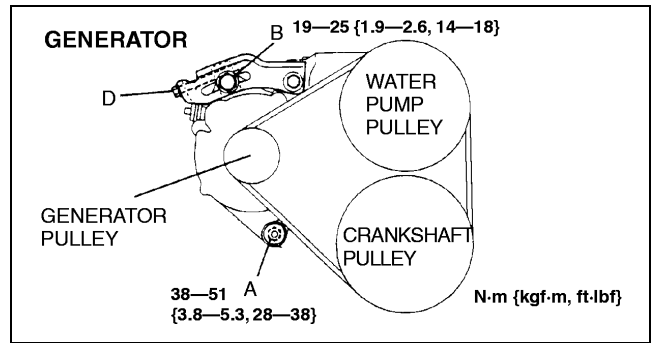

2. Adjust the belt deflection or tension by turning the adjusting bolt D.

### Caution

- If the belt is replaced with a new one or the belt has been on a running engine for less than 5 minutes, adjust deflection or tension to “New” specification. Then warm up the engine, allow it to cool, and adjust deflection or tension to “Used” specification.
- If the belt has been on a running engine for more than 5 minutes, adjust deflection or tension to “Used” specification.

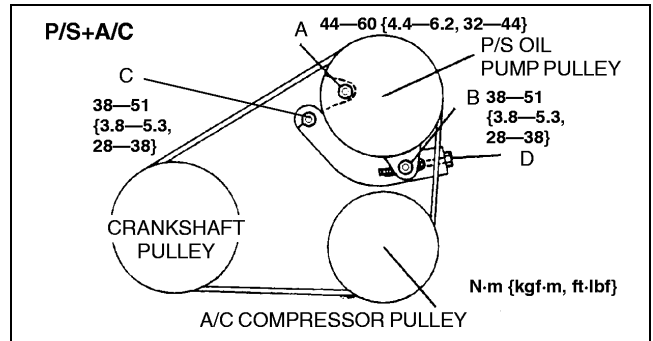
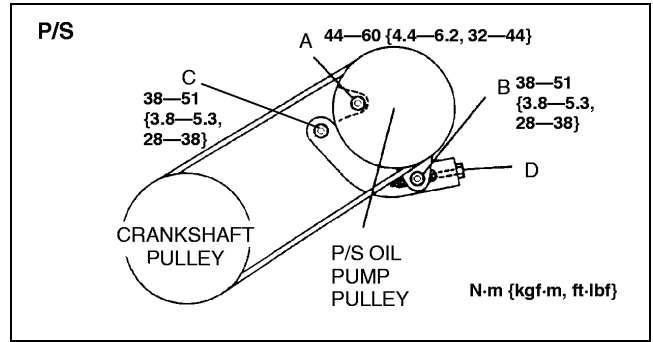

### Deflection

mm {in}

Drive belt	New	Used
Generator	5.5—7.0 {0.22—0.27}	6.0—7.5 {0.24—0.29}
P/S, P/S+A/C	7.0—8.0 {0.28—0.31}	9.0—10.0 {0.36—0.39}

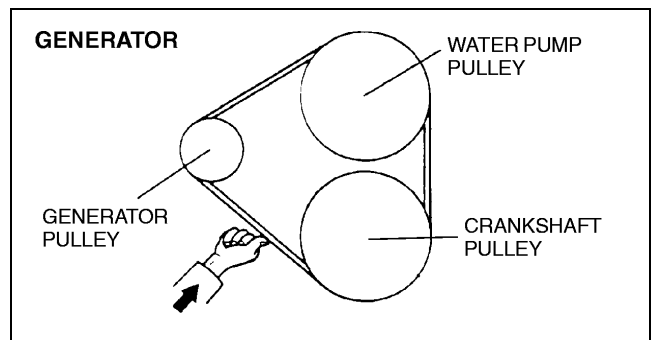

# MECHANICAL [ZM]

## Tension

Drive belt	N {kgf, lbf}	
	New	Used
Generator	500—740 {50—76, 110—160}	500—700 {50—72, 110—150}
P/S, P/S+A/C	590—680 {60—70, 140—150}	430—490 {43—50, 95—110}

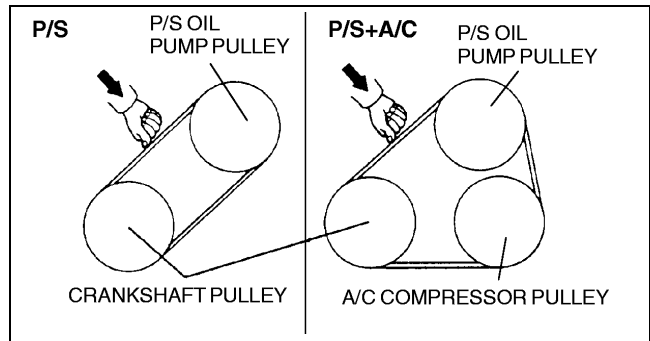

X3U110WA1

01-10A

3. Tighten mounting bolt A, B, and C.
4. Inspect the belt deflection or tension.
  - If not within “Used” specification, repeat from Step 1.

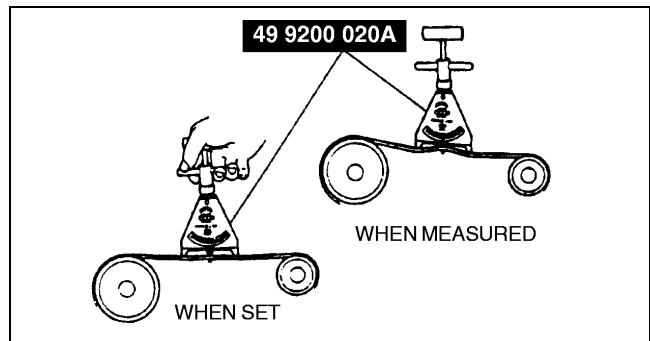

X3U110WA2

## VALVE CLEARANCE INSPECTION [ZM]

1. Remove the cylinder head cover. (See 01-10A-9 TIMING BELT REMOVAL/INSTALLATION [ZM].)
2. Verify that the engine is cold.
3. Measure the valve clearance.
  - (1) Turn the crankshaft clockwise so that the No.1 piston is at TDC of the compression stroke.

A3U011012010W03

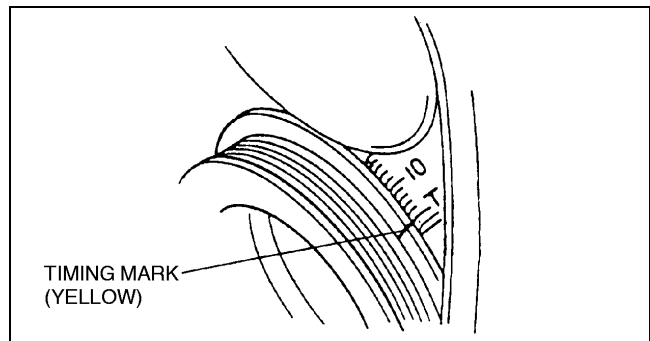

X3U110WA6

- (2) Measure the valve clearance at A in the figure.

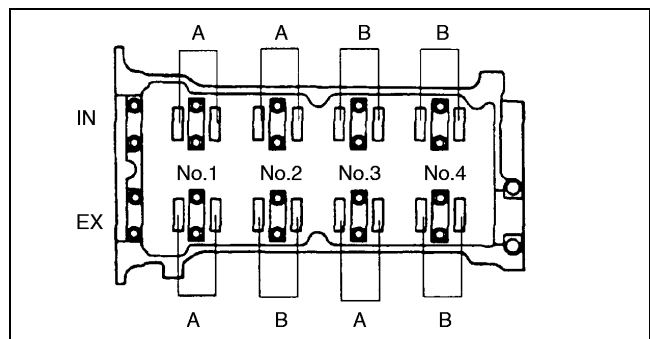

X3U110WA7

## MECHANICAL [ZM]

- If the valve clearance exceeds the standard, replace the adjustment shim. (See 01-10A-6 VALVE CLEARANCE ADJUSTMENT [ZM].)

### Standard [Engine cold]

IN: 0.25—0.31 mm {0.010—0.012 in}  
(0.28±0.03 mm {0.011±0.001 in})

EX: 0.25—0.31 mm {0.010—0.012 in}  
(0.28±0.03 mm {0.011±0.001 in})

- (3) Turn the crankshaft **360°** clockwise so that the No.4 piston is at TDC of the compression stroke.
- (4) Measure the valve clearance at B in the figure.
  - If the valve clearance exceeds the standard, replace the adjustment shim. (See 01-10A-6 VALVE CLEARANCE ADJUSTMENT [ZM].)

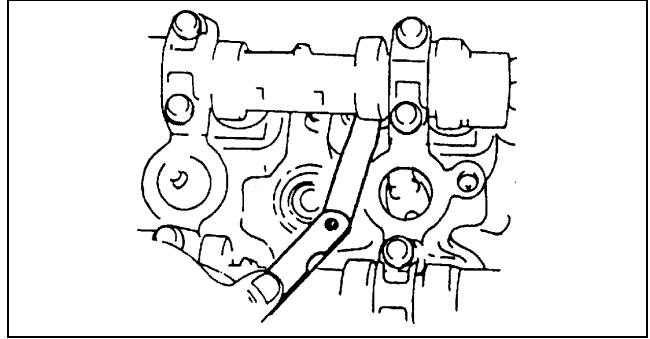

X3U110WA8

### Standard [Engine cold]

IN: 0.25—0.31 mm {0.010—0.012 in} (0.28±0.03 mm {0.011±0.001 in})

EX: 0.25—0.31 mm {0.010—0.012 in} (0.28±0.03 mm {0.011±0.001 in})

4. Install the cylinder head cover. (See 01-10A-9 TIMING BELT REMOVAL/INSTALLATION [ZM].)

## VALVE CLEARANCE ADJUSTMENT [ZM]

A3U011012010W04

Perform this same procedure for all camshafts requiring valve clearance adjustment.

1. Turn the crankshaft clockwise so that the cams on the camshaft requiring valve clearance adjustment are positioned straight up.
2. Remove the camshaft cap bolts as necessary.

### Note

- Remove only one pair of cap bolts at a time.
- Reinstall the cap bolts before removing the next pair.
  - A: For EX side No.1, 2, 3 cylinder adjustment shim removal.
  - B: For IN side No.1, 2, 3 cylinder adjustment shim removal.
  - C: For EX side No.2, 3, 4 cylinder adjustment shim removal.
  - D: For IN side No.2, 3, 4 cylinder adjustment shim removal.

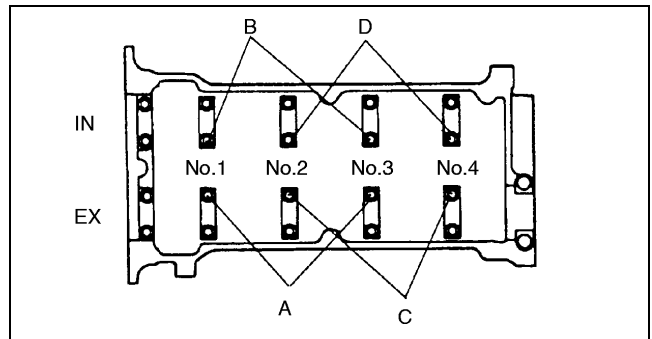

X3U110WA9

- For EX side No.2, 3 cylinder adjustment shim removal, remove either bolt A or C.
- For IN side No.2, 3 cylinder adjustment shim removal, remove either bolt B or D.

3. Install the **SSTs** on the camshaft using the camshaft cap bolt holes.

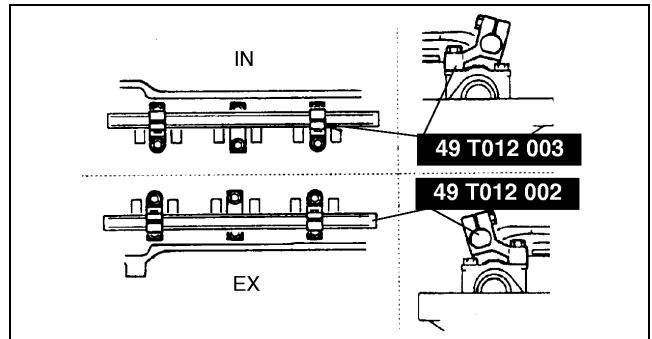

X3U110WAA

## Tightening torque

11.3—14.2 N·m {115—145 kgf·cm, 100—125 in·lbf}

01-10A

4. Align the marks on the **SSTs** (shaft and shaft clamp).
5. Tighten bolts A to secure the **SST** (shaft).

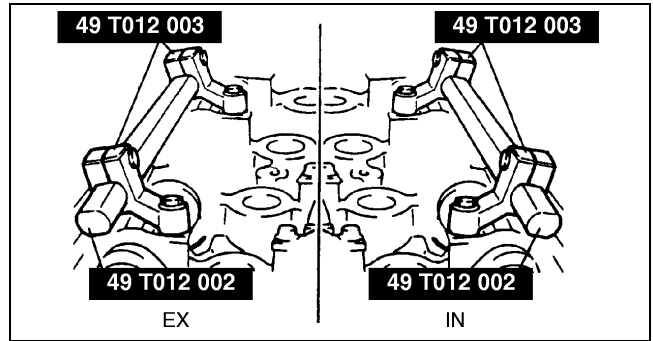

X3U110WAB

6. Face the **SST** (body) toward the center of the cylinder head, and mount it on the **SST** (shaft) at the point of the adjustment shim to be replaced.

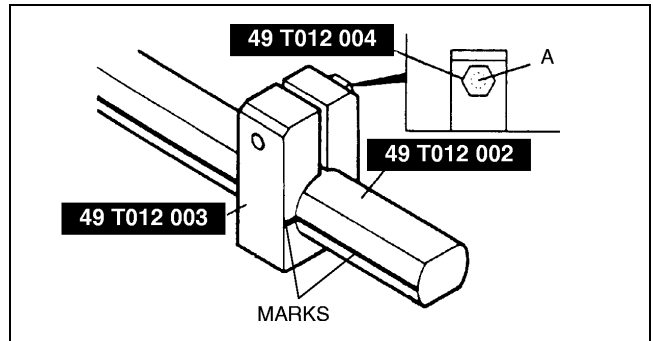

X3U110WAC

7. Face the notch of the tappet so that a fine screwdriver can be inserted.
8. Set the **SST** on the tappet by its notch.

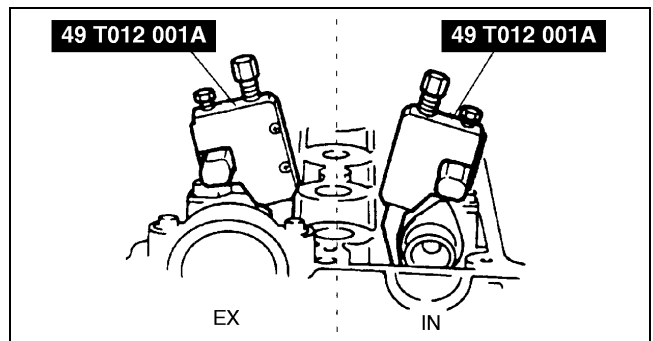

X3U110WAD

9. Tighten bolt B to secure the **SST** (body).

### Caution

- Cylinder head can be damaged when the tappet is pressed down.

10. Tighten bolt C, and press down the tappet.

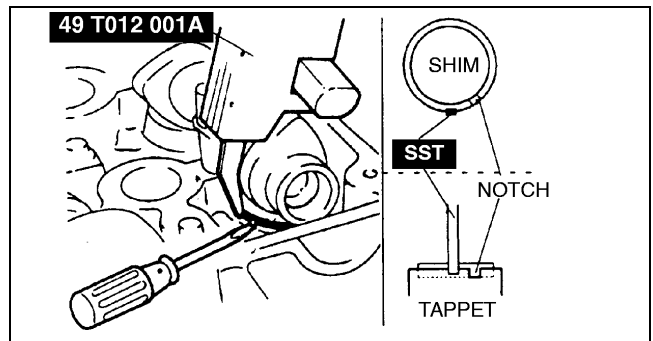

X3U110WAE

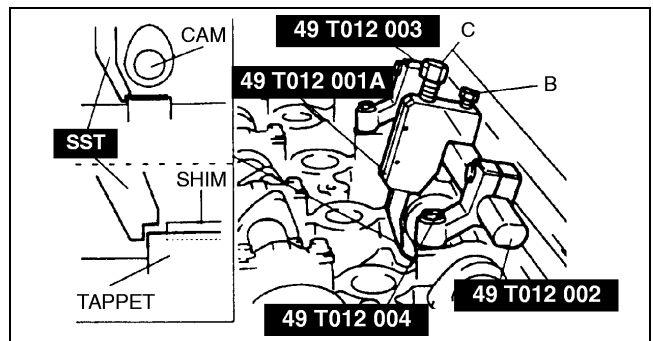

X3U110WAF

## MECHANICAL [ZM]

11. Using a fine screwdriver, pry up the adjustment shim through the notch on the tappet. Remove the shim using a magnet.
12. Select proper adjustment shim.

### New adjustment shim

$$= \text{Removed shim thickness} + \text{Measured valve clearance} - \text{Standard valve clearance} \\ (0.28 \text{ mm } \{0.011 \text{ in}\})$$

13. Push the selected shim into the tappet.
14. Loosen bolt C to allow the tappet to move up.
15. Loosen bolt B and remove the **SST** (body).
16. Remove the **SSTs** and tighten the camshaft cap bolts.

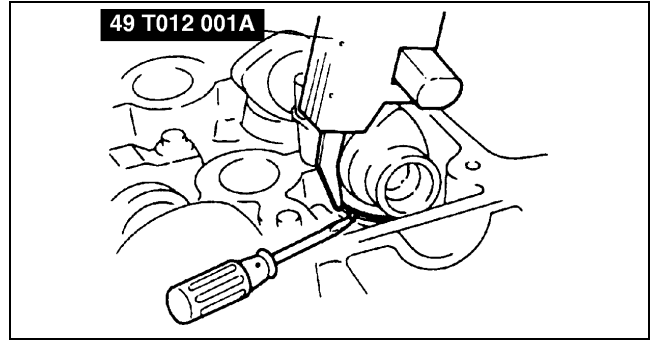

X3U110WAG

### Tightening torque

$$11.3\text{--}14.2 \text{ N}\cdot\text{m} \{115\text{--}145 \text{ kgf}\cdot\text{cm}, 100\text{--}125 \text{ in}\cdot\text{lbf}\}$$

17. Inspect the valve clearance. (See 01–10A–5 VALVE CLEARANCE INSPECTION [ZM].)

## COMPRESSION INSPECTION [ZM]

A3U011002000W05

### Warning

- When the engine and the oil are hot, they can cause severe burns. Be careful not to burn yourself during removal/installation of each component.

1. Verify that the battery is fully charged.
  - Recharge it if necessary. (See 01–17–1 Battery.)
2. Warm up the engine to the normal operating temperature.
3. Stop the engine and allow it to cool off for **about 10 min**.
4. Perform “Fuel Line Safety Procedure”. Leave the fuel pump relay removed. (See 01–14–4 BEFORE REPAIR PROCEDURE.)
5. Remove the ignition coils. (See 01–18–1 IGNITION COIL REMOVAL/INSTALLATION.)
6. Remove the spark plugs.
7. Connect a compression gauge into the No.1 spark plug hole.
8. Fully depress the accelerator pedal and crank the engine.
9. Note the maximum gauge reading.
10. Inspect each cylinder as below.
  - If the compression in one or more cylinders is low or the compression difference between cylinders exceeds the maximum, pour a small amount of clean engine oil into the cylinder and reinspect the compression.
    - If the compression increases, the piston, the piston rings, or cylinder wall may be worn and overhaul is required.
    - If the compression stays low, a valve may be stuck or improperly seated and overhaul is required.
    - If the compression in adjacent cylinders stays low, the cylinder head gasket may be damaged or the cylinder head distorted and overhaul is required.

### Compression

kPa {kgf/cm<sup>2</sup>, psi} [rpm]

Item	Engine type
	ZM
Standard	1,373 {14.0, 199} [300]
Minimum	981 {10.0, 142} [300]
Maximum difference between cylinders	196 {2.0, 28}

1. Disconnect the compression gauge.
2. Install the spark plugs.

### Tightening torque

$$15\text{--}22 \text{ N}\cdot\text{m} \{1.5\text{--}2.3 \text{ kgf}\cdot\text{m}, 11\text{--}16 \text{ ft}\cdot\text{lbf}\}$$

3. Install the ignition coils.
4. Install the fuel pump relay.

## 01–10A–8

## TIMING BELT REMOVAL/INSTALLATION [ZM]

1. Disconnect the negative battery cable.
2. Remove the CMP sensor. (See 01-40A-35 CAMSHAFT POSITION (CMP) SENSOR REMOVAL/INSTALLATION [ZM].)
3. Remove the ignition coils. (See 01-18-1 IGNITION COIL REMOVAL/INSTALLATION.)
4. Remove the drive belt. (See 01-10A-4 DRIVE BELT ADJUSTMENT [ZM].)
5. Remove in the order indicated in the table.
6. Install in the reverse order of removal.
7. Inspect the air gap. (See 01-40A-32 Air Gap Inspection.)
8. Adjust the drive belt deflection/tension. (See 01-10A-4 DRIVE BELT ADJUSTMENT [ZM].)
9. Start the engine and:
  - (1) Inspect the pulleys and drive belt for runout and contact.
  - (2) Inspect the ignition timing. (See 01-10A-25 Ignition Timing Inspection.)

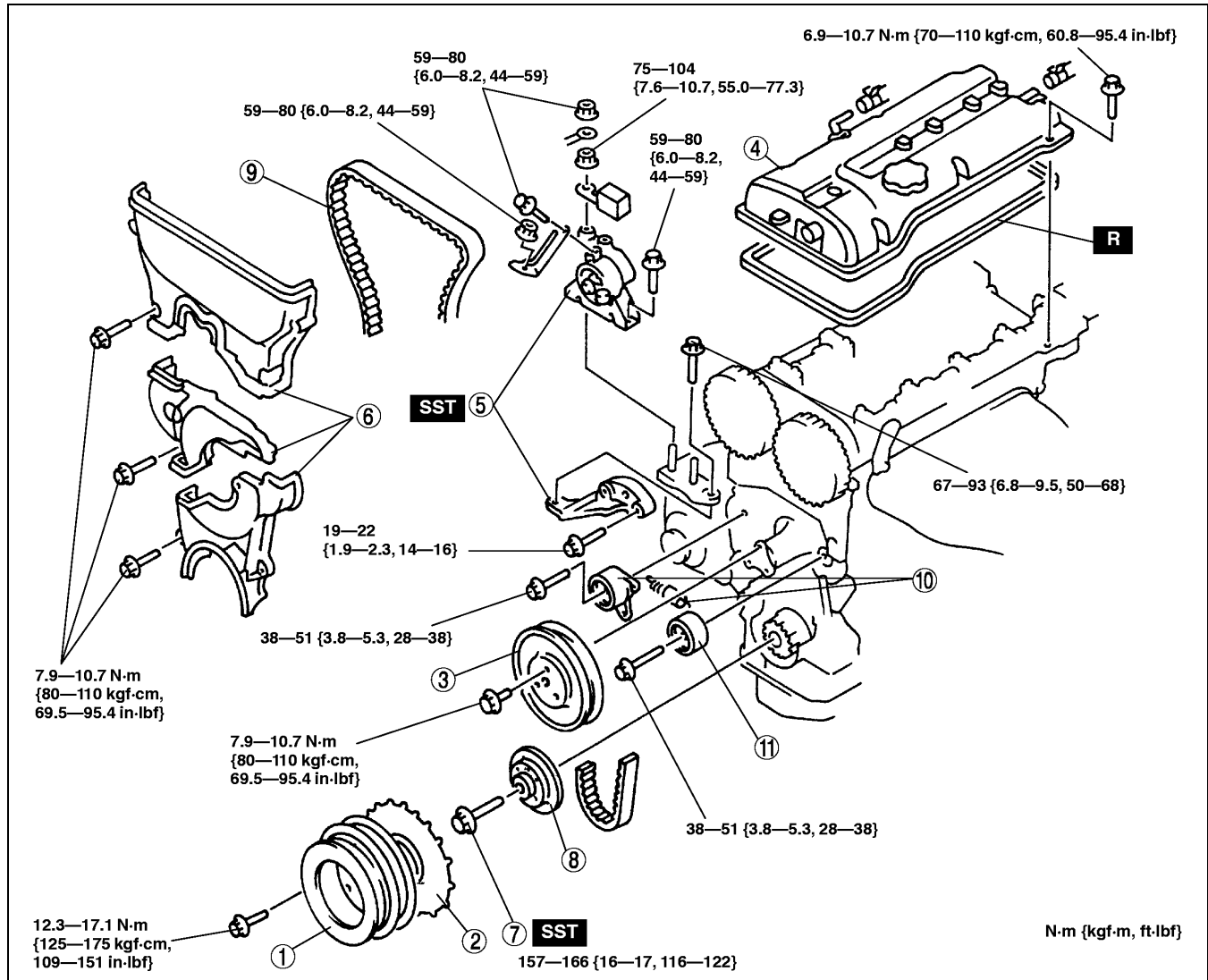

X3U110WAH

1	Crankshaft pulley
2	Plate
3	Water pump pulley
4	Cylinder head cover (See 01-10A-13 Cylinder Head Cover Installation Note)
5	No.3 engine mount (See 01-10A-10 No.3 Engine Mount Removal Note) (See 01-10A-13 No.3 Engine Mount Installation Note)
6	Timing belt cover

7	Pulley lock bolt (See 01-10A-10 Pulley Lock Bolt Removal/Installation Note)
8	Pulley boss
9	Timing belt (See 01-10A-10 Timing Belt Removal Note) (See 01-10A-11 Timing Belt Installation Note)
10	Tensioner, tensioner spring (See 01-10A-11 Tensioner, Tensioner Spring Installation Note)
11	Idler

## No.3 Engine Mount Removal Note

1. Suspend the engine using the **SST**.

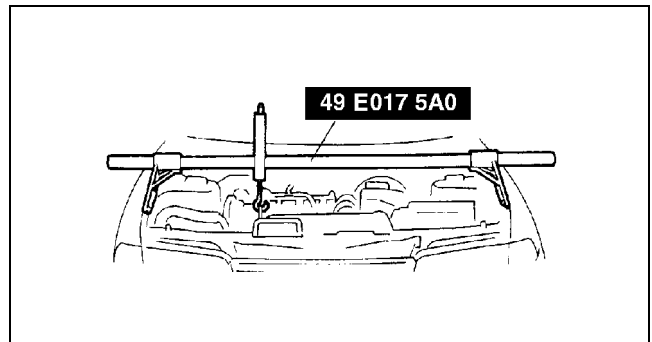

Z3U110WAJ

## Pulley Lock Bolt Removal/Installation Note

1. Remove the crankshaft using the **SST**.

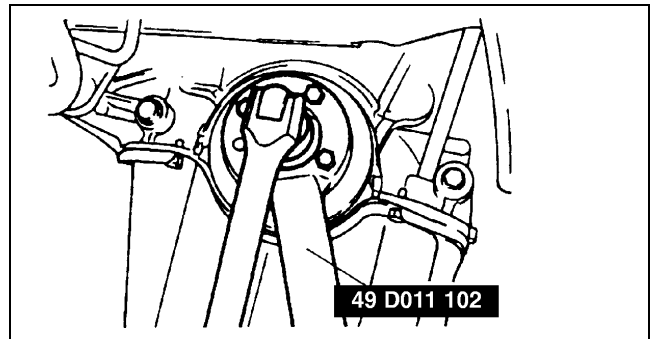

X3U110WAK

## Timing Belt Removal Note

1. Install the pulley boss and pulley lock bolt.
2. Turn the crankshaft clockwise and align the timing marks.

### Note

- Face the marks (I) and (E) of the camshaft pulley straight up, then align the timing marks with the horizontal surface on the cylinder head.
- The pulley boss position pin on the crankshaft should be facing straight up.

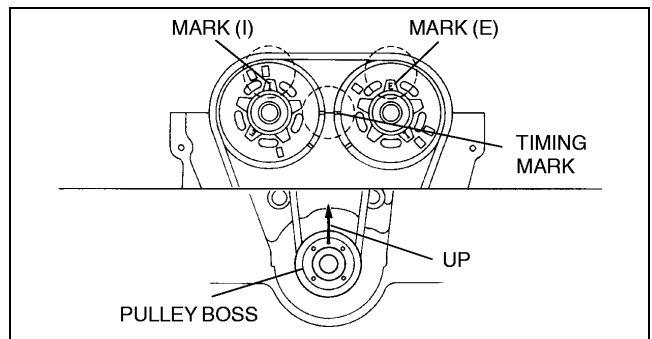

X3U110WAL

3. Loosen the tensioner lock bolt.
4. Push the tensioner in the direction of the arrow and hand-tighten the lock bolt.

### Caution

- **Forcefully twisting is the timing belt turning it inside out, or allowing oil or grease on it will damage the belt and shorten its life.**

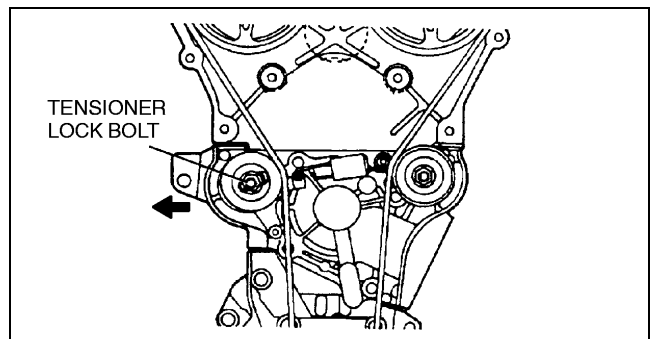

X3U110WAM



**Note**

- Mark the timing belt rotation on the belt for proper reinstallation.

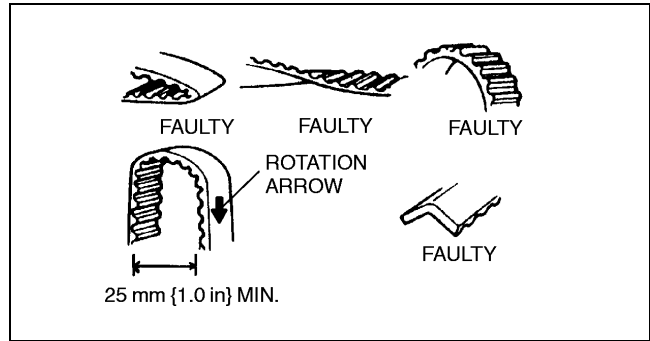

X3U110WAN

**Tensioner, Tensioner Spring Installation Note**

1. Measure the tensioner spring free length.
  - If not as specified, replace the tensioner spring.

**Free length**  
61.8 mm {2.43 in}

2. Install the tensioner.

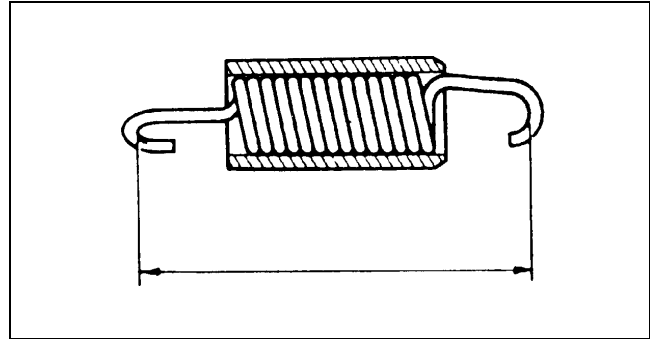

X3U110WAP

3. Install the tensioner spring with the damper rubber closing face on the right side.
4. Temporarily secure the tensioner with the spring fully extended.

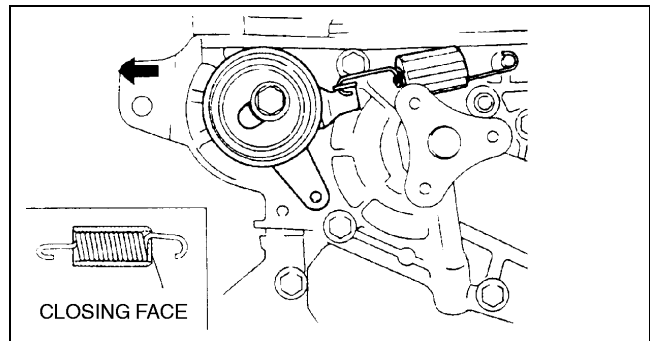

X3U110WAQ

**Timing Belt Installation Note**

1. Verify that the timing belt pulley mark and camshaft pulley marks are aligned with the timing marks as shown.

**Note**

- Face the marks (I) and (E) of the camshaft pulley straight up, then align the timing marks with the horizontal surface on the cylinder head.

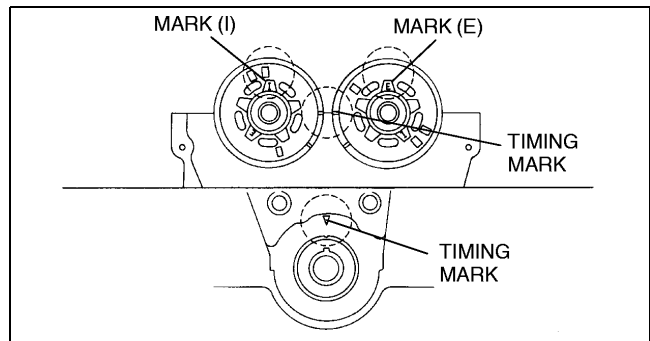

X3U110WAR

## MECHANICAL [ZM]

2. Install the timing belt in the order shown to prevent looseness.

### Caution

- Be sure not to apply tension other than that of the tensioner spring.

3. Install the pulley boss and pulley lock bolt.
4. Loosen the tensioner lock bolt to apply tension to timing belt.

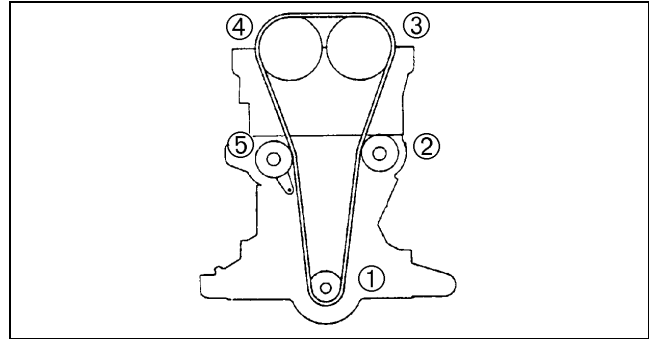

X3U110WAS

5. Turn the crankshaft clockwise **1 and 5/6 times**, and align the timing belt pulley mark with the tensioner set mark.

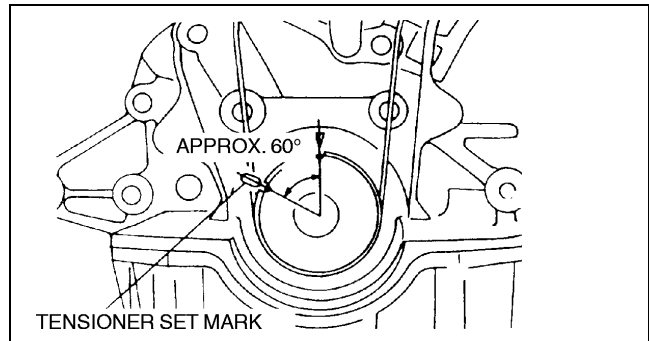

X3U110WAT

6. Hold the crankshaft using the **SST**, and remove the pulley lock bolt and the pulley boss.
7. Verify that the timing belt pulley mark is aligned with the tensioner set mark.

### Caution

- Prevent the tensioner from moving with the tensioner lock bolt as it is turned.

8. Tighten the tensioner lock bolt.
9. Install the pulley boss and the pulley lock bolt.
10. Turn the crankshaft **2 and 1/6 times**, and face the pin on the pulley boss straight up.
11. Verify that the camshaft pulley marks are aligned with the timing marks as shown.

- If not, repeat from **Timing Belt Removal Note** and reinstall the timing belt. (See 01-10A-10 Timing Belt Removal Note.)

### Note

- Timing is normal if: the pulley boss position pin and the camshaft pulley marks (I) and (E) are facing straight up. the timing marks are aligned to the horizontal surface on cylinder head.

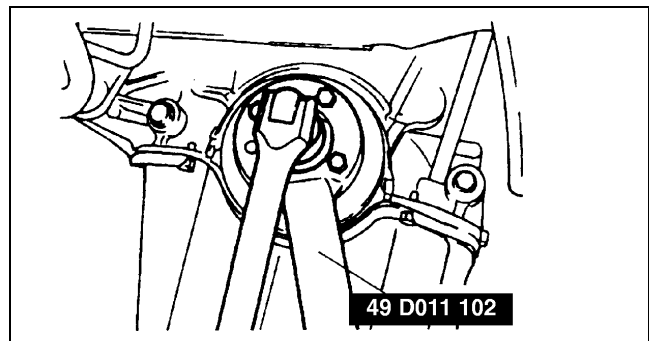

X3U110WAW

12. Inspect the timing belt deflection at the point indicated by applying moderate pressure **98 N {10 kgf, 22 lbf}**.
  - If not as specified, remove the timing belt and repeat from Step 1.

### Timing belt deflection

6.0—7.5 mm {0.24—0.29 in}

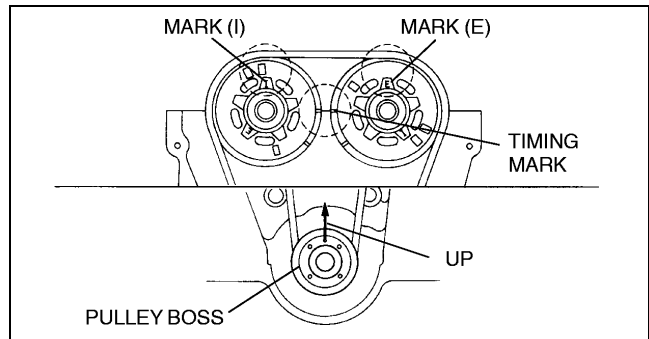

X3U110WAV

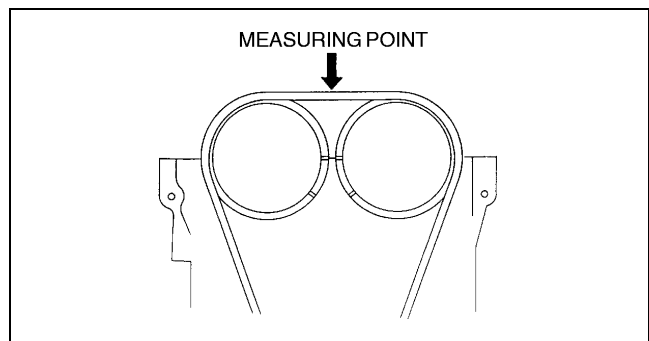

X3U110WAW

## No.3 Engine Mount Installation Note

1. Install the No.3 engine mount. (See 01-10A-22 No.3 Engine Mount Installation Note.)
2. Remove the **SST** (engine support).

## Cylinder Head Cover Installation Note

1. Verify that the grooves on the cylinder head cover are free of oil, water and other foreign material.
2. Install the cylinder head cover gasket into the cylinder head cover.
3. Apply silicone sealant to the cylinder head as shown.

### Thickness

3.0—4.0 mm {0.12—0.15 in}

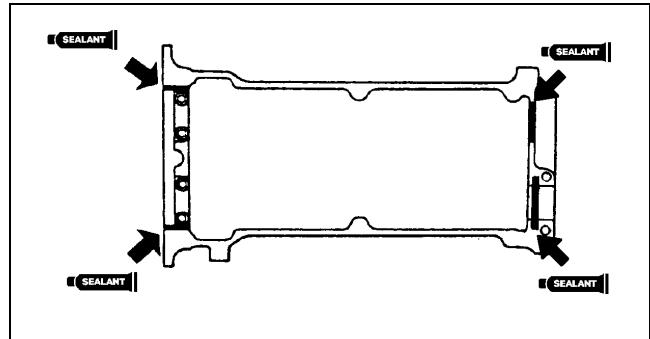

X3U110WAX

4. Tighten the cylinder head cover bolts a few turns in the order shown.

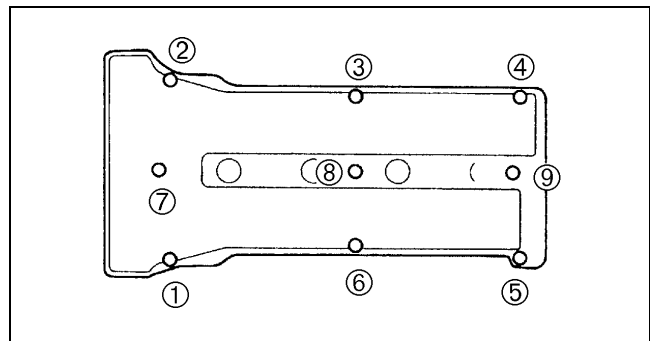

X3U110WAY

## CYLINDER HEAD GASKET REPLACEMENT [ZM]

A3U011010271W02

### Warning

- Fuel vapor is hazardous. It can very easily ignite, causing serious injury and damage. Always keep sparks and flames away from fuel.
- Fuel line spills and leakage are dangerous. Fuel can ignite and cause serious injuries or death and damage. Fuel can also irritate skin and eyes. To prevent this, always complete the "Fuel Line Safety Procedure". (See 01-14-4 BEFORE REPAIR PROCEDURE.)

1. Disconnect the negative battery cable.
2. Drain the engine coolant. (See 01-12-2 COOLING SYSTEM SERVICE WARNINGS.) (See 01-12-3 ENGINE COOLANT REPLACEMENT.)
3. Remove the timing belt. (See 01-10A-9 TIMING BELT REMOVAL/INSTALLATION [ZM].)
4. Remove the front pipe, exhaust manifold insulator, and EGR pipe. (See 01-15-1 EXHAUST SYSTEM REMOVAL/INSTALLATION.)
5. Remove the air cleaner, and fresh-air duct.
6. Disconnect the accelerator cable, and bracket.
7. Disconnect the vacuum hose, and engine harness connector.
8. Disconnect the plastic fuel hoses. (See 01-14-11 Plastic Fuel Hose Removal Note.) (See 01-14-12 Plastic Fuel Hose Installation Note.)
9. Remove the intake manifold bracket.
10. Remove the heater hoses.
11. Remove in the order indicated in the table.
12. Install in the reverse order of removal.
13. Inspect for fuel leakage.
14. Inspect the compression. (See 01-10A-8 COMPRESSION INSPECTION [ZM].)
15. Start the engine and
  - (1) Inspect the pulleys and drive belt for runout and contact.
  - (2) Inspect the ignition timing. (See 01-10A-25 Ignition Timing Inspection.)
  - (3) Inspect the idle speed. (See 01-10A-26 Idle Speed Adjustment.)

# MECHANICAL [ZM]

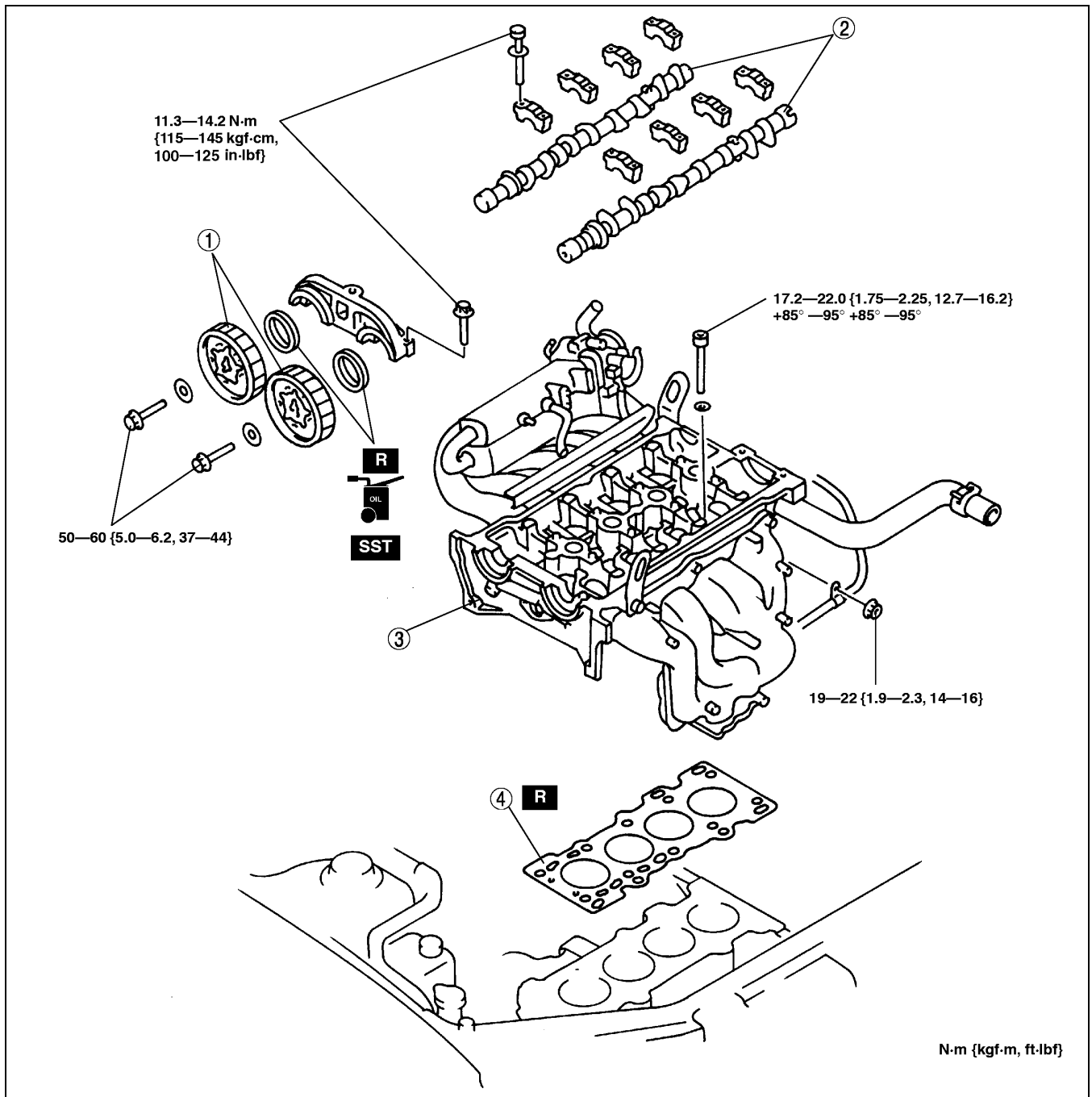

Y3U110WA0

1	Camshaft pulley (See 01-10A-14 Camshaft Pulley Removal Note) (See 01-10A-17 Camshaft Pulley Installation Note)
2	Camshaft (See 01-10A-15 Camshaft Removal Note) (See 01-10A-16 Camshaft Installation Note)

3	Cylinder head (See 01-10A-15 Cylinder Head Removal Note) (See 01-10A-15 Cylinder Head Installation Note)
4	Cylinder head gasket

## Camshaft Pulley Removal Note

1. Temporarily install the No.3 engine mount.
2. Remove the **SST** (engine support).

3. Hold the camshaft using a wrench on the cast hexagon as shown.

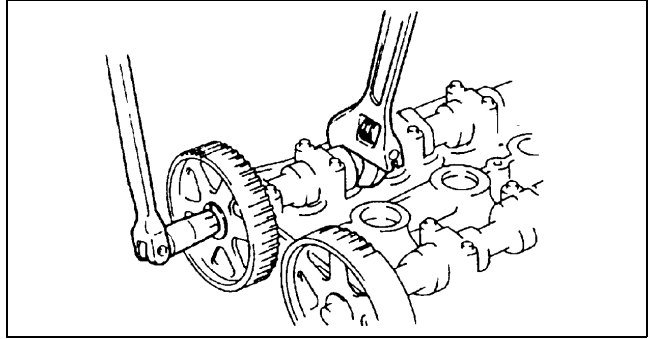

X3U110WB0

### Camshaft Removal Note

1. Loosen the camshaft cap bolts a few turns in the order shown.
2. Remove the camshaft cap.

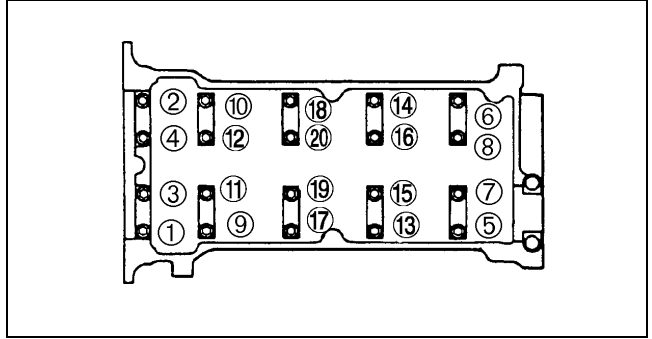

X3U110WB1

### Cylinder Head Removal Note

1. Loosen the cylinder head bolts a few turns in the order shown.

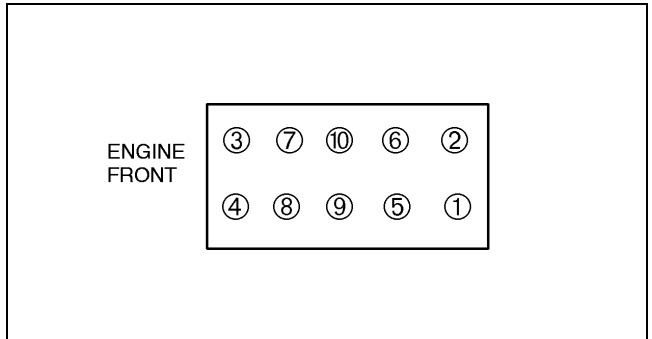

X3U110WB2

### Cylinder Head Installation Note

1. Measure the length of each bolt.
  - Replace any that exceed the maximum length.

**Standard length**  
 99.2—99.8 mm {3.91—3.92 in}  
**Maximum length**  
 100.5 mm {3.956 in}

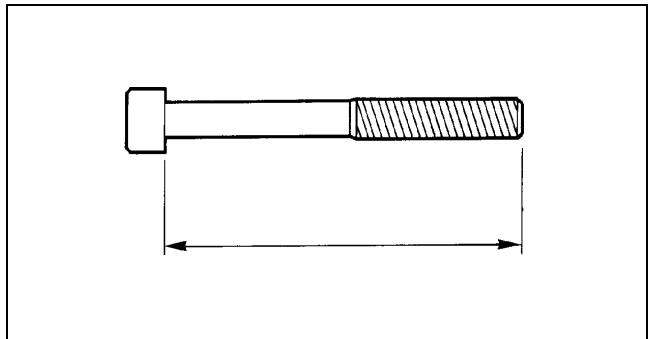

X3U110WB3

## MECHANICAL [ZM]

2. Tighten the cylinder head bolts a few turns in the order shown.

### Tightening torque

17.2—22.0 N·m {1.75—2.25 kgf·m, 12.7—16.2 ft·lbf}

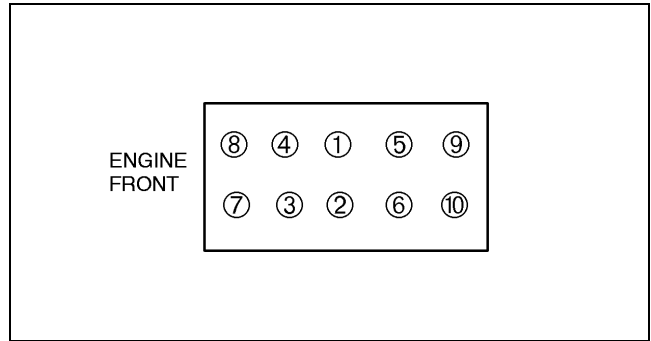

X3U110WB4

3. Put a paint mark on each bolt head.
4. Using the marks as a reference, tighten the bolts by turning each  $85^{\circ}$ — $95^{\circ}$  in the sequence shown.
5. Further tighten each bolt by turning another  $85^{\circ}$ — $95^{\circ}$  in the sequence shown.

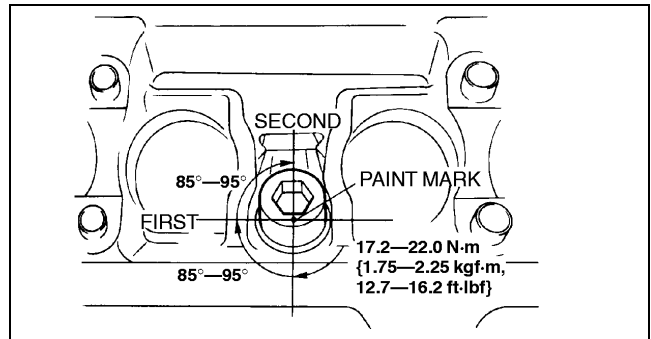

X3U110WB5

### Camshaft Installation Note

#### Caution

- Because there is little camshaft thrust clearance, the camshaft must be held horizontally while it is installed. Otherwise, excessive force will be applied to the thrust area, causing a burr on the thrust receiving area of the cylinder head journal. To avoid this, the following procedure must be observed.

1. Assemble camshaft onto the cylinder head, facing the cam noses at No.1 and No.3 cylinders as shown.

#### Note

- Keep the camshaft sliding surface free of sealant to prevent engine damage.

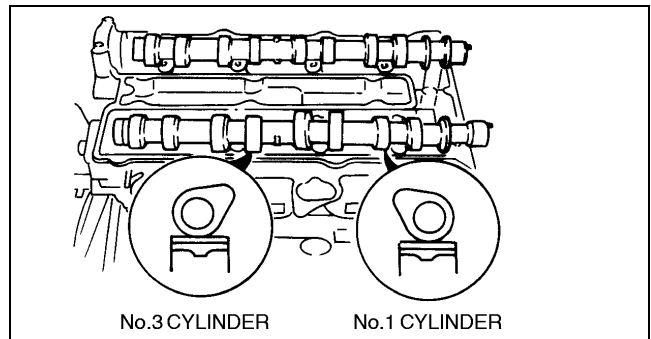

X3U110WB6

2. Apply silicone sealant to the areas shown.

### Thickness

1.0 mm {0.04 in}

3. Apply engine oil to the camshaft and the cylinder head journals.
4. Install the camshaft caps to the positions from which they were removed.

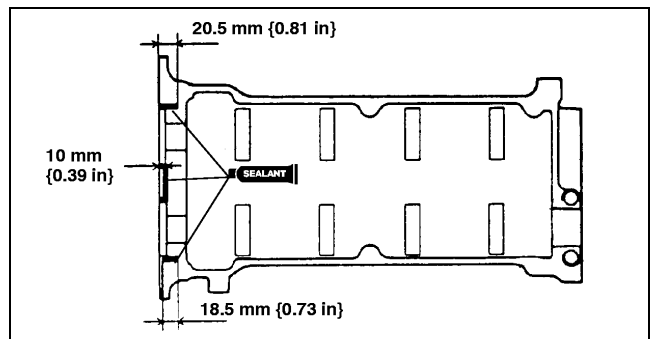

X3U110WB7

## MECHANICAL [ZM]

01-10A

5. Hand tighten the camshaft cap bolts marked 5, 7, 2, and 4.
6. Tighten the camshaft cap bolts a few turns in the order shown.
7. Verify that the camshaft settles horizontally when 2 bearing cap bolts at No.3 journal are tightened.
8. Apply clean engine oil to the camshaft oil seal.
9. Push the oil seal slightly in by hand.

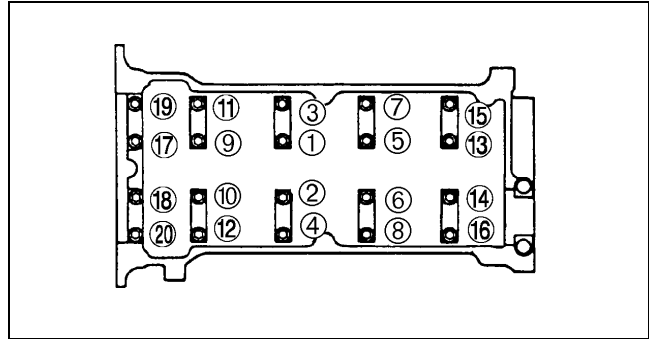

X3U110WB8

10. Tap the oil seals in evenly using the **SST** and a hammer.

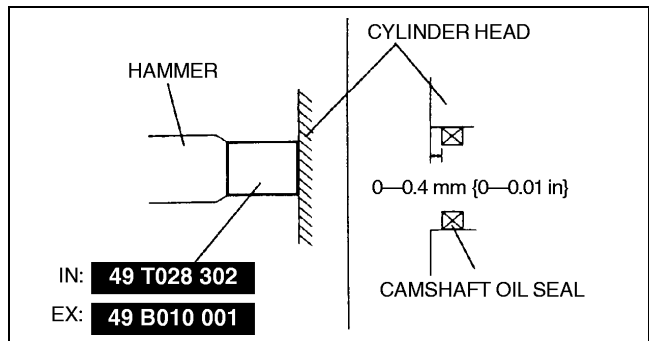

Y3U110WA1

### Camshaft Pulley Installation Note

1. Install the camshaft pulleys with the "I" mark (intake side) or "E" mark (exhaust side) straight up.

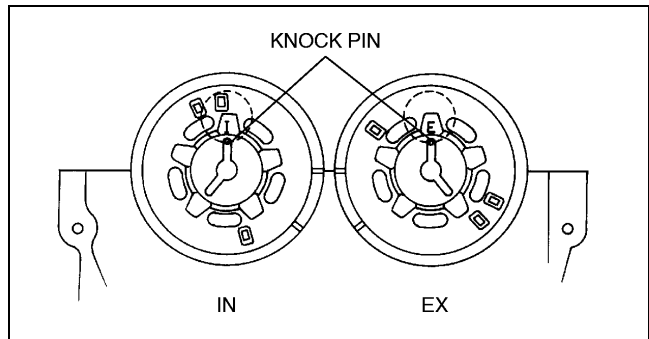

X3U110WBA

2. Hold the camshaft using a wrench on the cast hexagon as shown.

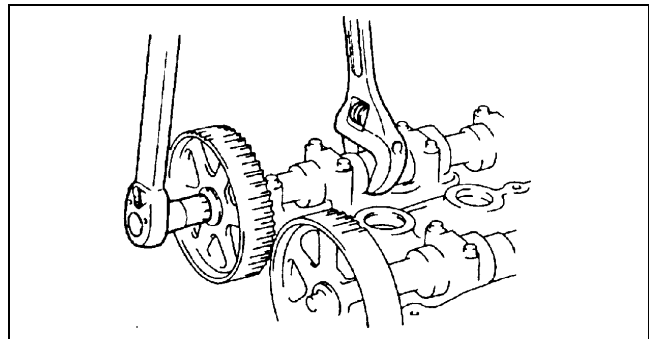

X3U110WBB

## MECHANICAL [ZM]

3. Suspend the engine using the **SST**.
4. Remove the No.3 engine mount.

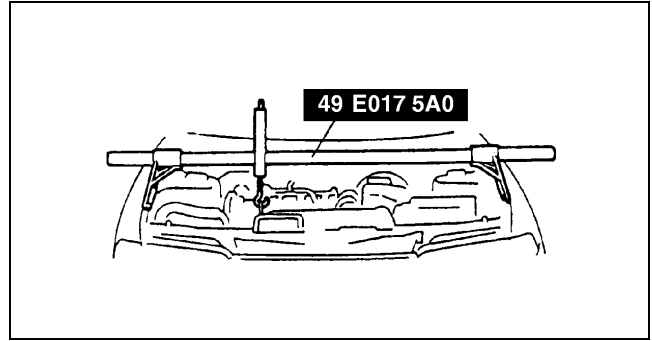

Z3U110WBC

### FRONT OIL SEAL REPLACEMENT [ZM]

A3U011010602W02

1. Disconnect the negative battery cable.
2. Remove the timing belt. (See 01-10A-9 TIMING BELT REMOVAL/INSTALLATION [ZM].)
3. Remove in the order indicated in the table.

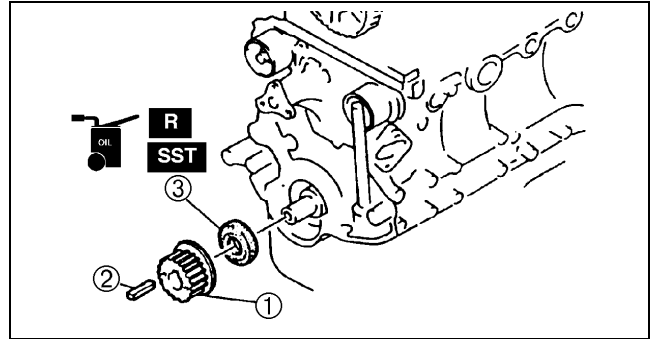

X3U110WBD

1	Timing belt pulley
2	Key
3	Front oil seal (See 01-10A-18 Front Oil Seal Removal Note) (See 01-10A-18 Front Oil Seal Installation Note)

4. Install in the reverse order of removal.

#### Front Oil Seal Removal Note

1. Cut the oil seal lip using a razor.
2. Remove the oil seal using a screwdriver protected with a rag.

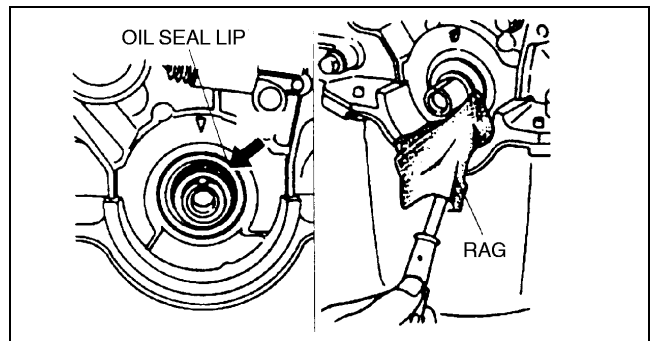

X3U110WBE

#### Front Oil Seal Installation Note

1. Apply clean engine oil to the oil seal lip.
2. Push the oil seal slightly in by hand.



## MECHANICAL [ZM]

- Tap the oil seal in evenly using the **SST** and a hammer.

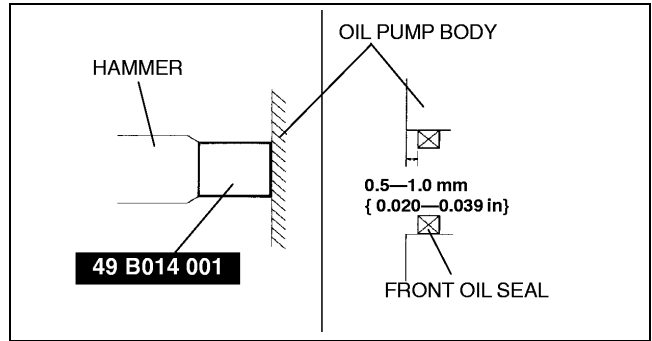

X3U110WBF

01-10A

### REAR OIL SEAL REPLACEMENT [ZM]

A3U011011399W02

- Remove the flywheel. (MTX) (See 05-10-11 CLUTCH UNIT REMOVAL/INSTALLATION.)
- Remove the drive plate. (ATX) (See 05-17-46 DRIVE PLATE REMOVAL/INSTALLATION.)
- Remove in the order indicated in the table.

1	Rear oil seal (See 01-10A-19 Rear Oil Seal Removal Note) (See 01-10A-19 Rear Oil Seal Installation Note)
---	--

- Install in the reverse order of removal.

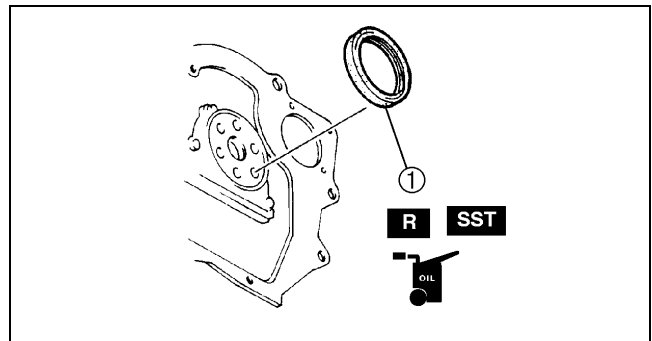

X3U110WBG

### Rear Oil Seal Removal Note

- Cut the oil seal lip using a razor.
- Remove the oil seal using a screwdriver protected with a rag.

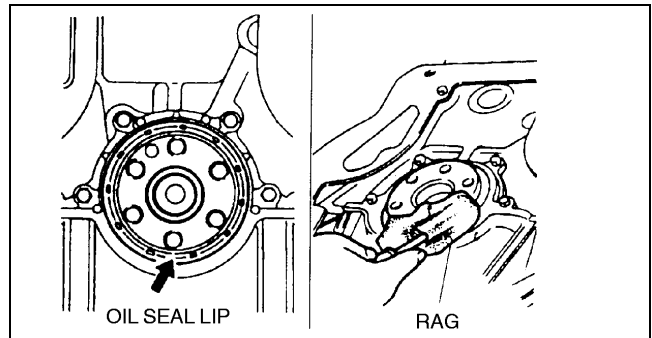

X3U110WBH

### Rear Oil Seal Installation Note

- Apply clean engine oil to the new oil seal lip.
- Push the oil seal slightly in by hand.
- Tap the oil seal in evenly using the **SSTs**.

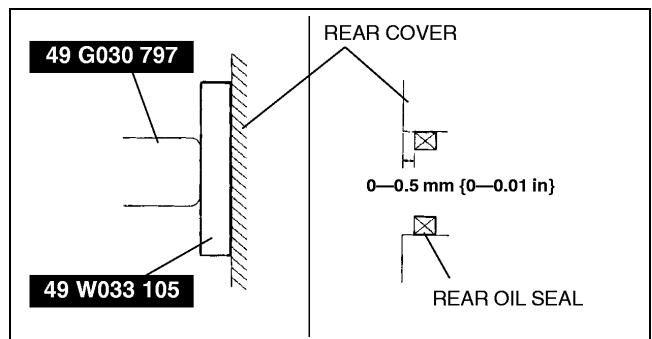

Y3U110WA2

### Warning

- Fuel vapor is hazardous. It can very easily ignite, causing serious injury and damage. Always keep sparks and flames away from fuel.
- Fuel line spills and leakage are dangerous. Fuel can ignite and cause serious injuries or death and damage. Fuel can also irritate skin and eyes. To prevent this, always complete the “Fuel Line Safety Procedure”. (See 01–14–4 BEFORE REPAIR PROCEDURE.)

1. Remove the battery.
2. Drain the engine coolant. (See 01–12–2 COOLING SYSTEM SERVICE WARNINGS.) (See 01–12–3 ENGINE COOLANT REPLACEMENT.)
3. Remove the air cleaner, air hose, and resonance chamber.
4. Remove the front pipe.
5. Disconnect the accelerator cable, bracket, heater hoses, vacuum hoses.
6. Remove the radiator. (See 01–12–4 RADIATOR REMOVAL/INSTALLATION.)
7. Remove the drive belt. (See 01–10A–4 DRIVE BELT ADJUSTMENT [ZM].)
8. Disconnect the plastic fuel hoses. (See 01–14–11 Plastic Fuel Hose Removal Note.) (See 01–14–12 Plastic Fuel Hose Installation Note.)
9. Disconnect the rods, cables, and clutch release cylinder related to the manual transaxle. (MTX) (See 05–15A–4 MANUAL TRANSAXLE (MTX) REMOVAL/INSTALLATION [F25M-R].)
10. Disconnect the rods, cables, and oil pipe related to the automatic transaxle. (ATX) (See 05–17–31 AUTOMATIC TRANSAXLE (ATX) REMOVAL/INSTALLATION.)
11. Remove the drive shaft. (See 03–13–9 DRIVE SHAFT REMOVAL/INSTALLATION.)
12. Remove the P/S oil pump with the oil hose still connected. Position the P/S oil pump so that it is out of the way.
13. Remove the A/C compressor with the pipe still connected. Position the A/C compressor so that it is out of the way.
14. Remove in the order indicated in the table.
15. Install in the reverse order of removal.
16. Adjust the drive belt deflection/tension. (See 01–10A–4 DRIVE BELT ADJUSTMENT [ZM].)
17. Start the engine and:
  - (1) Inspect for the engine oil, engine coolant, transaxle oil, ATF and fuel leakage.
  - (2) Verify the ignition timing, idle speed and idle mixture. (See 01–10A–25 ENGINE TUNE-UP [ZM].)
18. Perform a road test.

# MECHANICAL [ZM]

01-10A

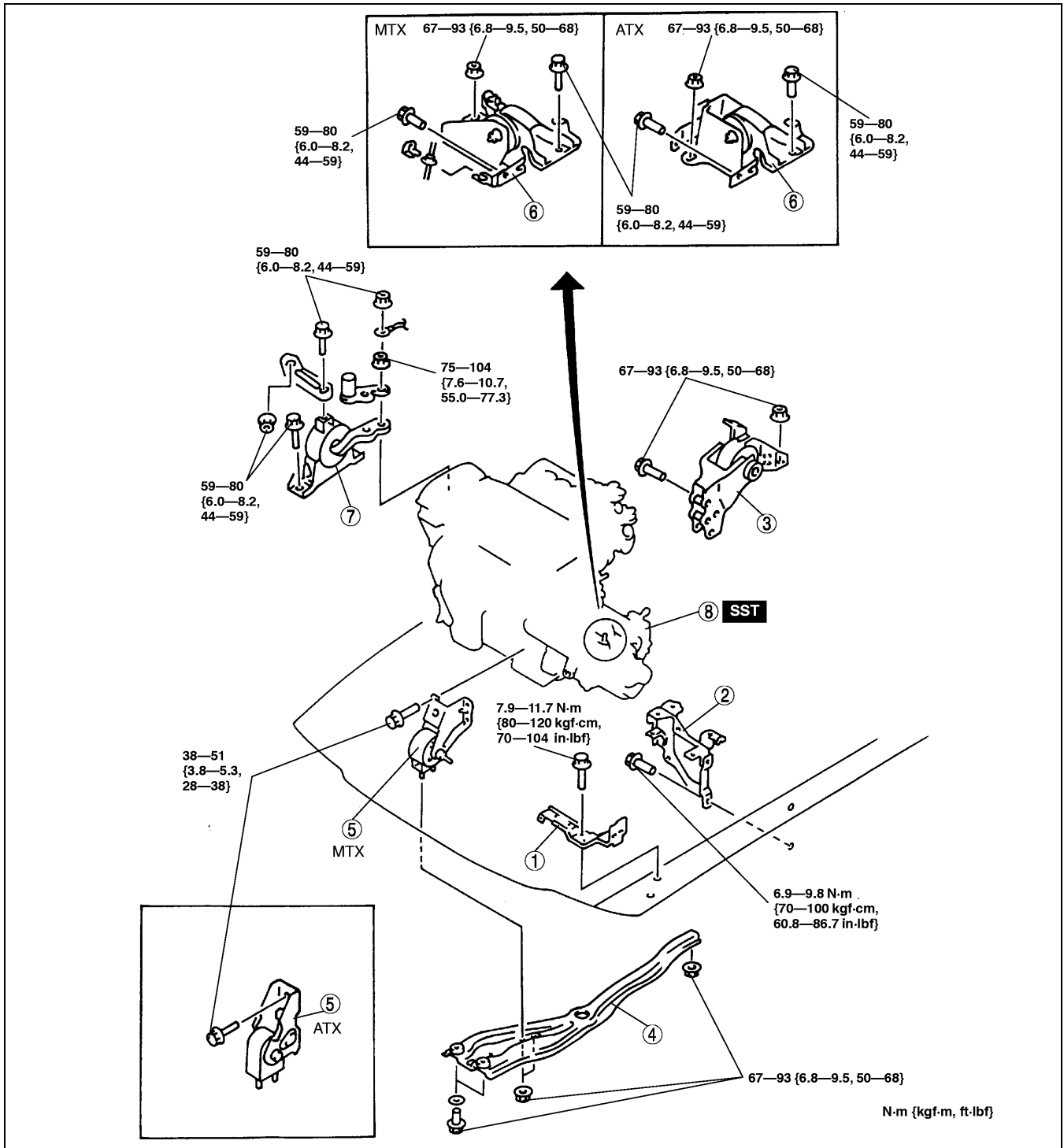

Y3U110WA3

1	Air cleaner bracket
2	Battery carrier bracket
3	No.1 engine mount (See 01-10A-22 No.1 Engine Mount Removal Note) (See 01-10A-23 No.1 Engine Mount Installation Note)
4	Engine mount member (See 01-10A-22 Engine Mount Member Removal Note) (See 01-10A-23 Engine Mount Member Installation Note)

5	No.2 engine mount (See 01-10A-23 No.2 Engine Mount Installation Note)
6	No.4 engine mount (See 01-10A-22 No.4 Engine Mount Removal Note) (See 01-10A-22 No.4 Engine Mount Installation Note)
7	No.3 engine mount (See 01-10A-22 No.3 Engine Mount Installation Note)
8	Engine, transaxle

## No.1 Engine Mount Removal Note

1. Suspend the engine using the **SST**.

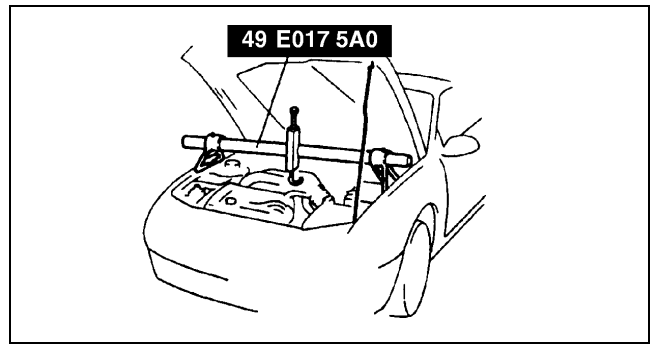

Z3U110WBL

## Engine Mount Member Removal Note

1. Remove the No.2 engine mount nut A.
2. Remove the engine mount member bolt and nut.

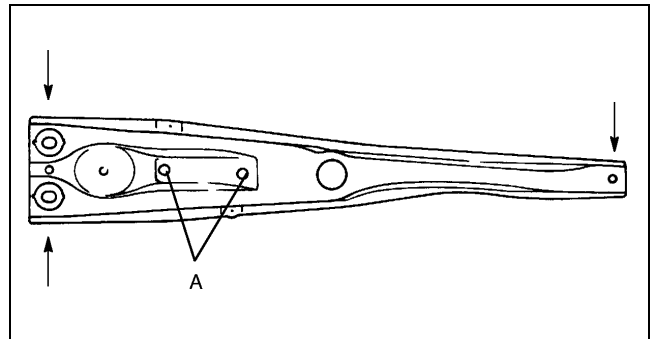

X3U110WBM

## No.4 Engine Mount Removal Note

1. Remove the **SST** (engine support) and securely support it with the chain block.

## No.3 Engine Mount Installation Note

1. Tighten the No.3 engine mount bolt and nut in the order shown.
2. Tighten the No.3 engine mount stay bolt and nut A.

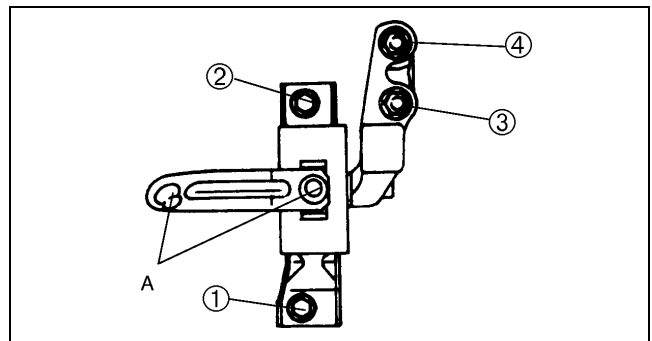

X3U110WBN

## No.4 Engine Mount Installation Note

1. Tighten the No.4 engine mount bolt A.

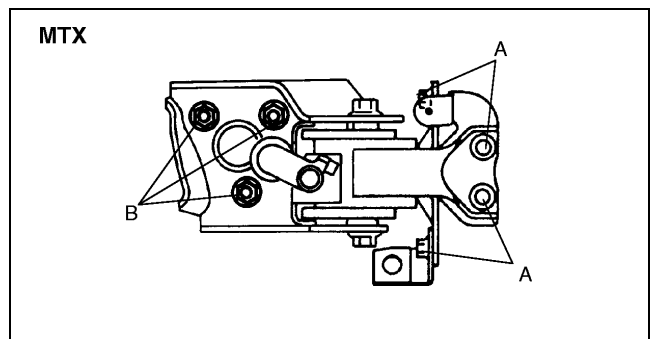

MTX

X3U110WBP

2. Tighten the No.4 engine mount nut B.

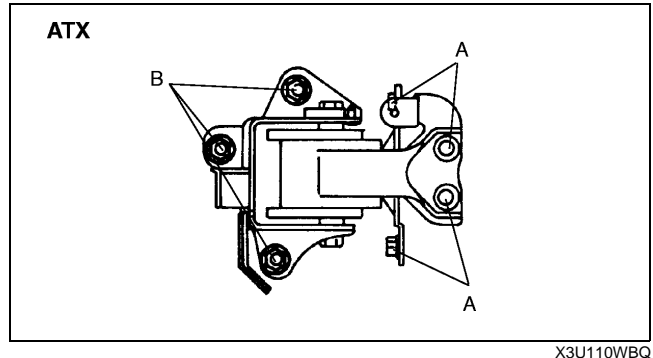

X3U110WBQ

01-10A

**No.2 Engine Mount Installation Note**

1. Remove the chain block.
2. Suspend the engine using the **SST**.

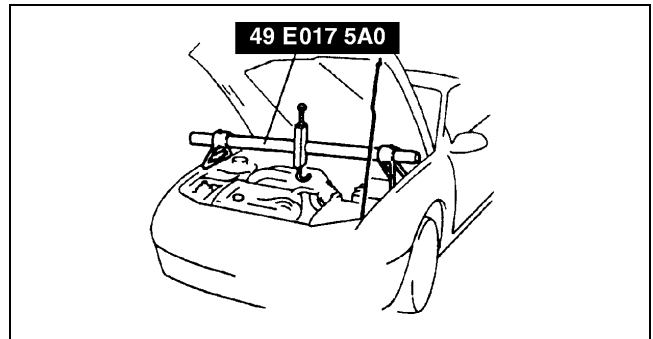

Z3U110WBR

**Engine Mount Member Installation Note**

1. Tighten the No.2 engine mount nut A.
2. Tighten the engine mount member bolt and nut.

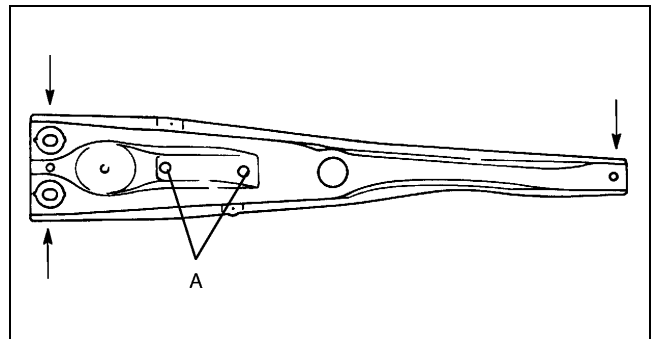

X3U110WBS

**No.1 Engine Mount Installation Note**

1. Tighten the No.1 engine mount bolt A.
2. Tighten the No.1 engine mount nut B.

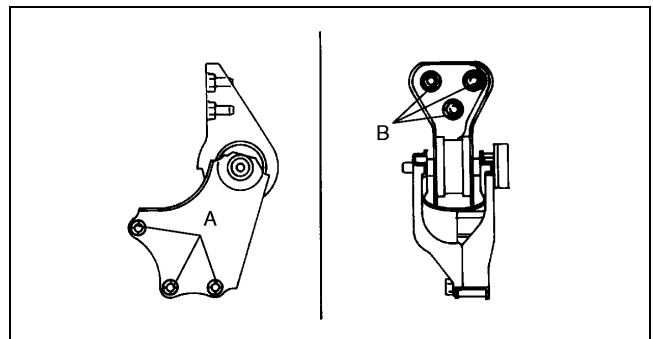

X3U110WBT

## MECHANICAL [ZM]

3. Loosen the No.2 engine mount bolt C.
4. Retighten the No.2 engine mount nut C.

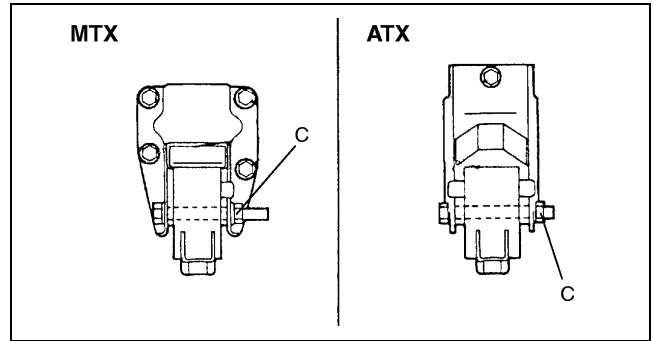

X3U110WBU

### ENGINE DISASSEMBLY/ASSEMBLY [ZM]

A3U011002000W07

1. Disconnect the engine and transaxle. (See 05-15A-4 MANUAL TRANSAXLE (MTX) REMOVAL/INSTALLATION [F25M-R].) (See 05-15A-4 MANUAL TRANSAXLE (MTX) REMOVAL/INSTALLATION [F25M-R].)
2. Remove the integrated stiffener. (See 01-11-8 Integrated Stiffener Installation Note.)
3. Remove the CKP sensor. (See 01-40A-34 CRANKSHAFT POSITION (CKP) SENSOR REMOVAL/INSTALLATION [ZM].)
4. Remove the oil pressure switch. (See 01-11-2 OIL PRESSURE INSPECTION.)
5. Remove the intake-air system. (See 01-13A-5 INTAKE-AIR SYSTEM REMOVAL/INSTALLATION [ZM].)
6. Remove the exhaust system. (See 01-15-1 EXHAUST SYSTEM REMOVAL/INSTALLATION.)
7. Remove the oil filter. (See 01-11-3 OIL FILTER REPLACEMENT.)
8. Remove the ignition coils.
9. Remove the generator.
10. Disassemble in the order indicated in the table.
11. Assemble in the reverse order of disassembly.
12. Inspect the air gap. (See 01-40A-32 Air Gap Inspection.)

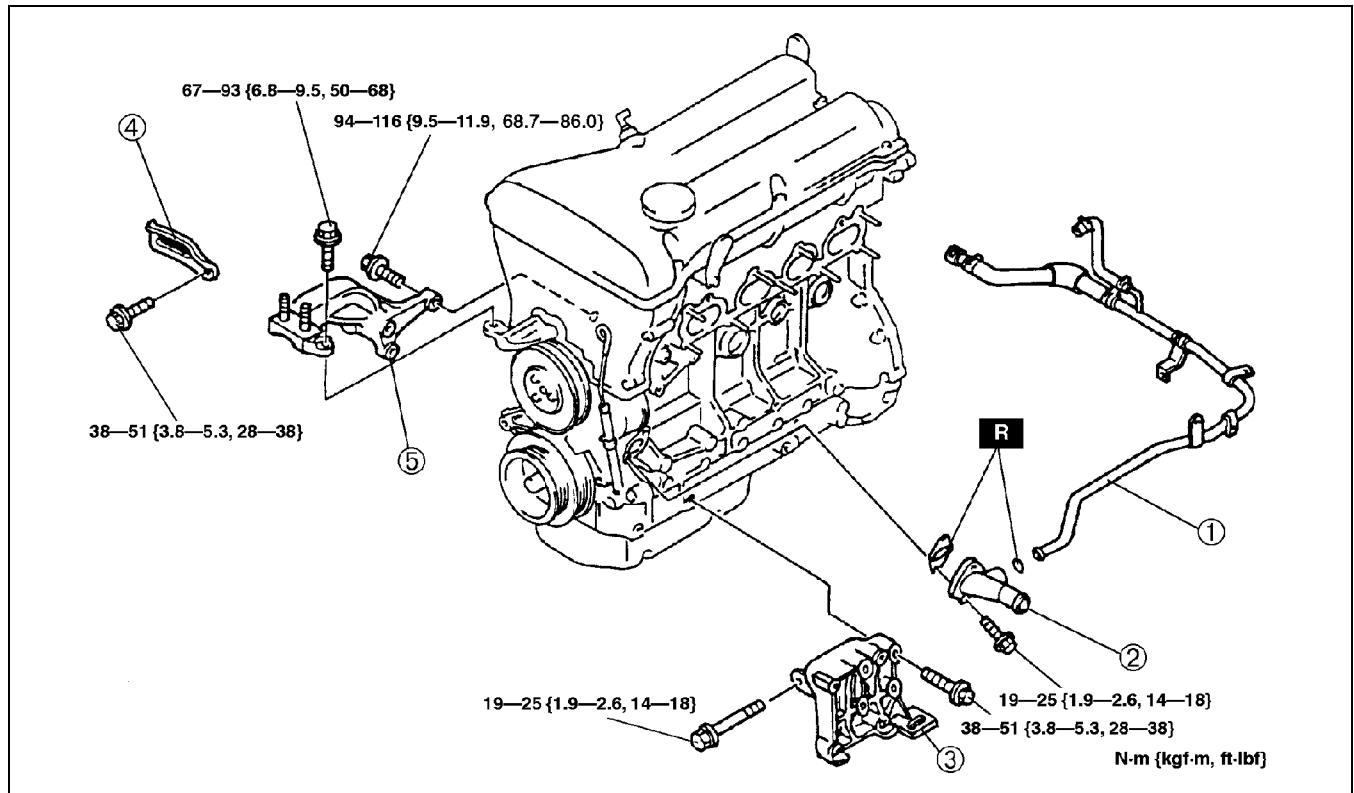

Y3U110WA4

1	Water bypass pipe
2	Water inlet pipe
3	A/C compressor bracket (with A/C compressor)

4	Generator strap
5	No.3 engine bracket

## ENGINE TUNE-UP [ZM]

A3U011002000W08

### Engine Tune-up Preparation

1. Warm up the engine to normal operating temperature.
2. Shift the transaxle into neutral.
3. Turn off all electrical loads.
  - Headlight switch
  - Fan switch
  - Rear window defroster switch
  - A/C switch
4. Verify that the steering wheel is at straight ahead position.
5. Connect the **SSTs** (WDS or equivalent) to the DLC-2.
6. Access RPM PID.
7. Wait until the electrical fan stops.

01-10A

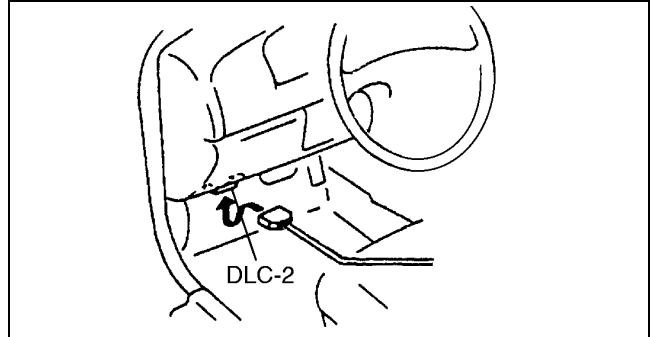

Z3U110WA5

### Ignition Timing Inspection

1. Perform "Engine Tune-up Preparation".
2. Verify that the RPM PID is within the specification.
  - If not as specified, adjust the idle speed. (See 01-10A-26 Idle Speed Adjustment.)

#### Specification

**650—750 (700±50) rpm**

3. Connect the timing light to the high-tension lead of the No.1 cylinder.
4. Verify that the timing mark (yellow) on the crankshaft pulley is within the specification.
  - If not as specified, inspect the following.
    - CMP sensor
    - CKP sensor
    - TP sensor
    - ECT sensor
    - Neutral switch (MTX)
    - Clutch switch (MTX)
    - TR switch (ATX)
  - If the devices are normal, replace the PCM. (See 01-40A-7 PCM REMOVAL/INSTALLATION [ZM].)

#### Ignition timing

**BTDC 9°—11° (10°±1°) (TIMING MARK [YELLOW])**

5. Connect the **SST** (System selector) to the DLC.
6. Set switch A to position 1.
7. Set the test switch to SELF TEST.

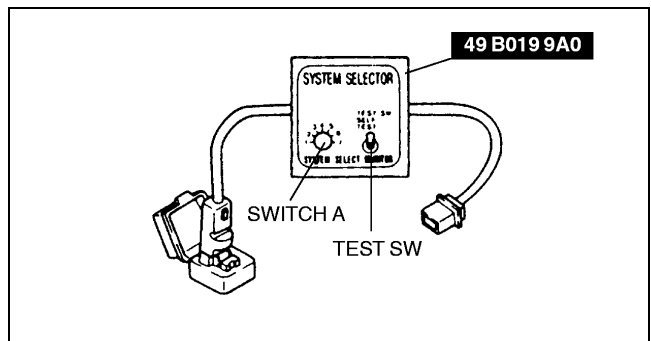

X3U110WC0

## MECHANICAL [ZM]

8. Verify that the timing mark (yellow) on the crankshaft pulley is within the specification.
  - If not as specified, inspect the following.
    - CMP sensor
    - CKP sensor
    - TP sensor
    - ECT sensor
    - Neutral switch (MTX)
    - Clutch switch (MTX)
    - TR switch (ATX)
  - If the devices are normal, replace the PCM. (See 01-40A-7 PCM REMOVAL/INSTALLATION [ZM].)

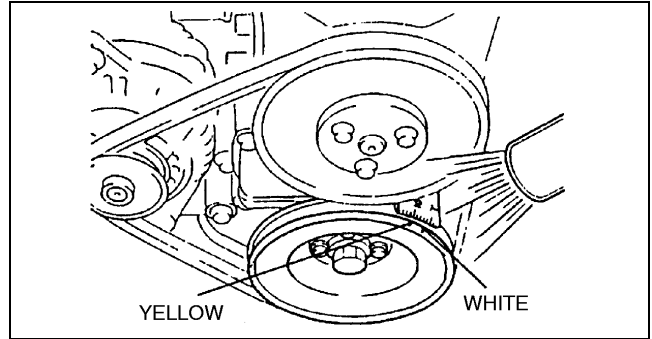

X3U110WBV

**Specification**  
BTDC 6°—18°

### Idle Speed Adjustment

1. Perform “Engine Tune-up Preparation”.
2. Verify that the RPM PID is within the specification.
  - If not as specified, adjust the idle speed by turning the AAS.

**Specification**  
650—750 (700±50) rpm

#### Caution

- The TAS is set at the factory and must not be adjusted. Any adjustment will negatively effect the engine performance.

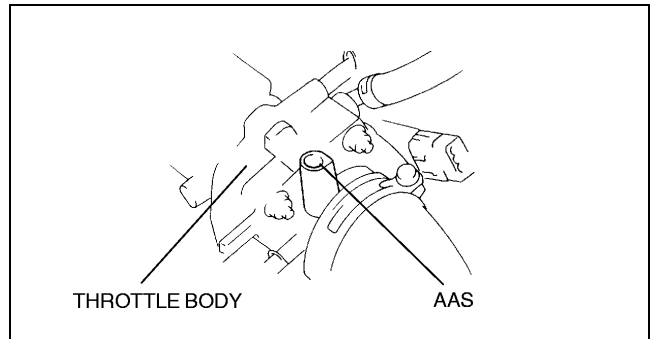

X3U110WBZ

3. Connect the **SST** (System selector) to the DLC.
4. Set switch A to position 1.
5. Set the test switch to SELF TEST.
6. Press **CLEAR** to clear previously selected items.
7. Disconnect the **SSTs**.

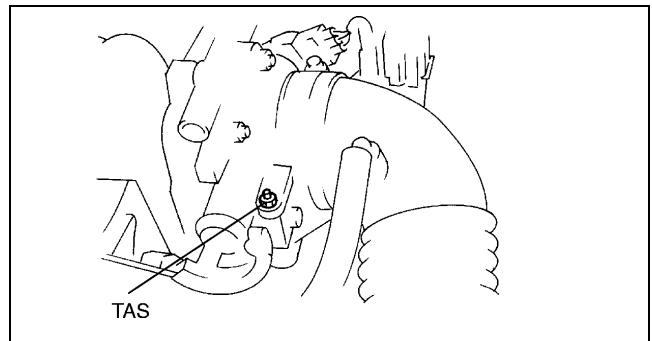

X3U110WC1

### Idle-up Speed Inspection

1. Perform “Engine Tune-up Preparation”.
2. Connect the **SST** (System selector) to the DLC.
3. Set switch A to position 1.
4. Set the test switch to SELF TEST.
5. Verify that the idle speed is normal. (See 01-10A-26 Idle Speed Adjustment.)
6. Verify that the RPM PID is within the specification.
  - If not as specified with all load conditions, inspect the IAC valve.
  - If not as specified with some load condition, inspect the related input switches, harnesses, and connectors.

#### Specification

Load condition	Idle-up speed (rpm)*1
E/L ON*2	650—750
P/S operating*3	700—800
A/C ON*4	700—800

\*1 : Excludes temporary idle speed drop just after the electrical loads (E/L) are turned on.



- \*2 : Headlight is on, Fan switch is above 1st, Cooling fan is operating, Rear window defroster is on.
- \*3 : Steering wheel is fully turned.
- \*4 : A/C switch and fan switch are on.

### Idle Mixture Inspection

1. Perform "Engine Tune-up Preparation".
2. Verify that the idle speed and ignition timing are within the specification. (See 01-10A-25 Ignition Timing Inspection.)(See 01-10A-26 Idle Speed Adjustment.)
3. Turn the test mode to OFF.
4. Warm up the engine by holding the engine speed at **2,500—3,000 rpm** for **approx. 3 min.**
5. Insert an exhaust gas analyzer to the tailpipe.
6. Verify that the CO and HC concentrations are within the regulation.
  - If not within the regulation, inspect the following:
    - On-board diagnostic system (See 01-02A-15 DTC TABLE [ZM].)
    - HO2S (See 01-40A-36 HEATED OXYGEN SENSOR (HO2S) INSPECTION [ZM].)
    - Intake manifold vacuum (See 01-03A-57 Intake Manifold Vacuum Inspection.)
    - Fuel line pressure (See 01-14-6 FUEL PRESSURE INSPECTION.)
    - Ignition timing control
      - If the systems and devices are normal, replace the TWC. (See 01-15-1 EXHAUST SYSTEM REMOVAL/INSTALLATION.)

## **01-10B MECHANICAL [FS]**

### **MECHANICAL LOCATION INDEX**

<b>[FS]</b> .....	<b>01-10B-2</b>	Camshaft Pulley Removal Note .....	<b>01-10B-15</b>
<b>DRIVE BELT INSPECTION [FS]</b> .....	<b>01-10B-3</b>	Camshaft Removal Note .....	<b>01-10B-16</b>
Drive Belt Deflection Inspection .....	<b>01-10B-3</b>	Cylinder Head Removal Note .....	<b>01-10B-16</b>
Drive Belt Tension Inspection .....	<b>01-10B-3</b>	Cylinder Head Installation Note .....	<b>01-10B-16</b>
<b>DRIVE BELT ADJUSTMENT [FS]</b> .....	<b>01-10B-4</b>	Camshaft Installation Note .....	<b>01-10B-17</b>
<b>VALVE CLEARANCE</b>		Camshaft Pulley Installation Note .....	<b>01-10B-18</b>
<b>INSPECTION [FS]</b> .....	<b>01-10B-5</b>	<b>FRONT OIL SEAL</b>	
<b>VALVE CLEARANCE</b>		<b>REPLACEMENT [FS]</b> .....	<b>01-10B-19</b>
<b>ADJUSTMENT [FS]</b> .....	<b>01-10B-6</b>	Front Oil Seal Removal Note .....	<b>01-10B-19</b>
<b>COMPRESSION INSPECTION [FS]</b> .....	<b>01-10B-8</b>	Front Oil Seal Installation Note .....	<b>01-10B-19</b>
Compression .....	<b>01-10B-8</b>	<b>REAR OIL SEAL</b>	
<b>TIMING BELT</b>		<b>REPLACEMENT [FS]</b> .....	<b>01-10B-20</b>
<b>REMOVAL/INSTALLATION [FS]</b> .....	<b>01-10B-8</b>	Rear Oil Seal Removal Note .....	<b>01-10B-20</b>
Crankshaft Pulley Removal Note .....	<b>01-10B-10</b>	Rear Oil Seal Installation Note .....	<b>01-10B-20</b>
Cylinder Head Cover Removal Note ..	<b>01-10B-10</b>	<b>ENGINE</b>	
No.3 Engine Mount Rubber		<b>REMOVAL/INSTALLATION [FS]</b> .....	<b>01-10B-21</b>
Removal Note .....	<b>01-10B-10</b>	Roll damper Installation Note .....	<b>01-10B-22</b>
Timing Belt Removal Note .....	<b>01-10B-10</b>	No.3, No.4 Engine Mount Installation	
Tensioner, Tensioner Spring		Note .....	<b>01-10B-23</b>
Installation Note .....	<b>01-10B-11</b>	<b>ENGINE</b>	
Timing Belt Installation Note .....	<b>01-10B-12</b>	<b>DISASSEMBLY/ASSEMBLY [FS]</b> .....	<b>01-10B-24</b>
Cylinder Head Cover		<b>ENGINE TUNE-UP [FS]</b> .....	<b>01-10B-25</b>
Installation Note .....	<b>01-10B-13</b>	Engine Tune-up Preparation .....	<b>01-10B-25</b>
Crankshaft Pulley Installation Note ...	<b>01-10B-14</b>	Ignition Timing Inspection .....	<b>01-10B-25</b>
Water Pump Pulley Installation Note ..	<b>01-10B-14</b>	Idle Speed Adjustment .....	<b>01-10B-26</b>
<b>CYLINDER HEAD GASKET</b>		Idle-up Speed Inspection .....	<b>01-10B-26</b>
<b>REPLACEMENT [FS]</b> .....	<b>01-10B-14</b>	Idle Mixture Inspection .....	<b>01-10B-26</b>

**01-10B**

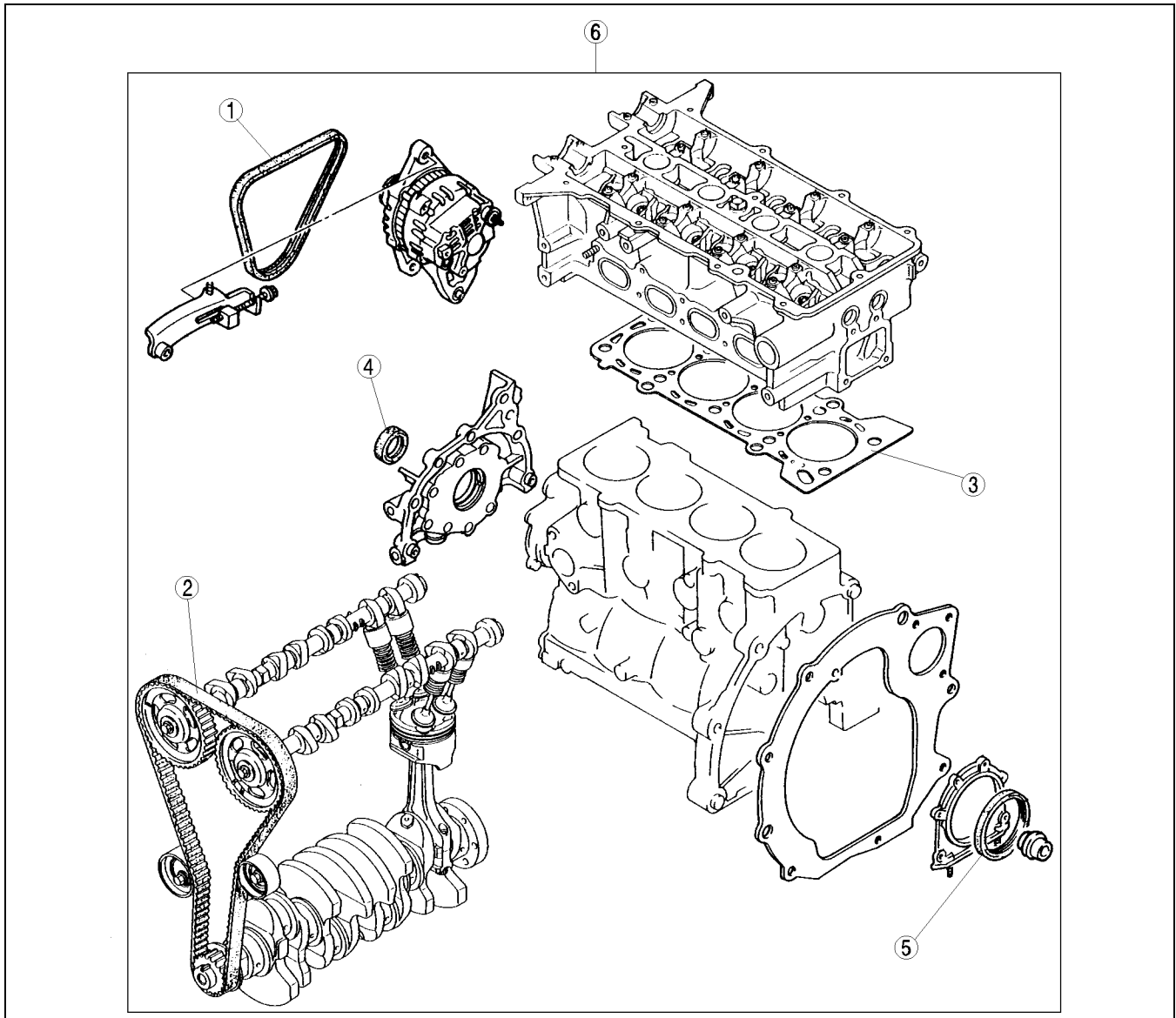

Z3U0110W100

1	Drive belt (See 01-10B-3 DRIVE BELT INSPECTION [FS]) (See 01-10B-4 DRIVE BELT ADJUSTMENT [FS])
2	Timing belt (See 01-10B-8 TIMING BELT REMOVAL/ INSTALLATION [FS])
3	Cylinder head gasket (See 01-10B-14 CYLINDER HEAD GASKET REPLACEMENT [FS])

4	Front oil seal (See 01-10B-19 FRONT OIL SEAL REPLACEMENT [FS])
5	Rear oil seal (See 01-10B-20 REAR OIL SEAL REPLACEMENT [FS])
6	Engine (See 01-10B-21 ENGINE REMOVAL/ INSTALLATION [FS]) (See 01-10B-24 ENGINE DISASSEMBLY/ ASSEMBLY [FS])

## DRIVE BELT INSPECTION [FS]

A3U011015800W01

Inspect the drive belt tension or deflection, as necessary.

### Drive Belt Deflection Inspection

**Note**

- Inspect the drive belt deflection when the engine is cold, or **at least 30 min** after the engine has stopped.

- Apply moderate pressure **98 N {10 kgf, 22 lbf}** midway between the specified pulleys.

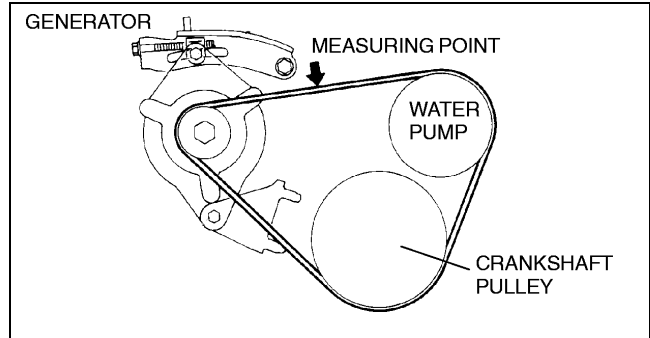

- If the deflection is not within the specification, adjust it. (See 01-10B-4 DRIVE BELT ADJUSTMENT [FS].)

**Deflection**

mm {in}

Drive belt	Limit
Generator	10.0 {0.39}
P/S, P/S+A/C	11.0 {0.43}

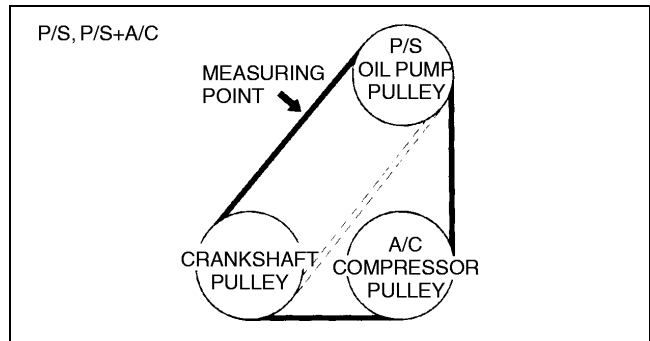

### Drive Belt Tension Inspection

**Note**

- Belt tension can be inspected in place of belt deflection. Inspect the drive belt tension when the engine is cold, or **at least 30 min** after the engine has been stopped.

- Using the **SST**, inspect the belt tension between any two pulleys.
  - If the tension is not within the specification, adjust it. (See 01-10B-4 DRIVE BELT ADJUSTMENT [FS].)

**Tension**

N {kgf, lbf}

Drive belt	Limit
Generator	390 {40, 88}
P/S, P/S+A/C	390 {40, 88}

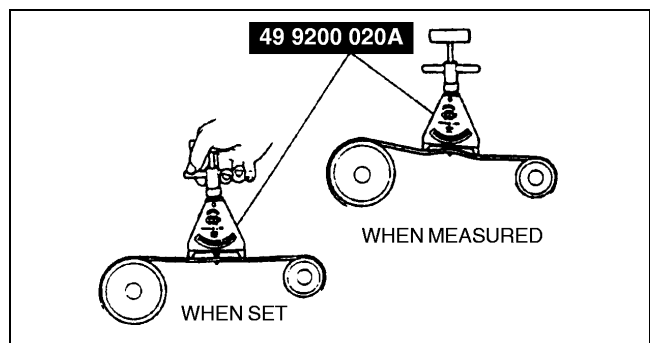

# MECHANICAL [FS]

## DRIVE BELT ADJUSTMENT [FS]

A3U011015800W02

1. Loosen mounting bolt A and B.

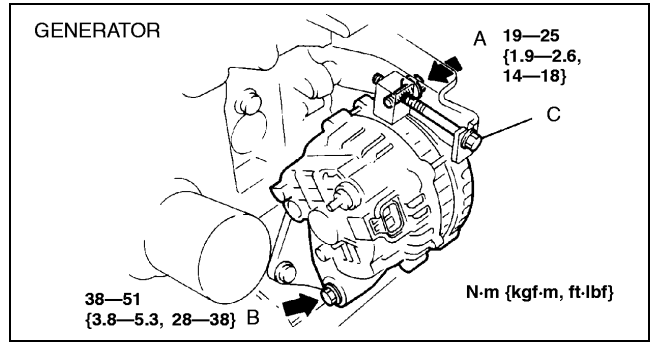

X3U110WF3

2. Adjust the belt deflection or tension by turning the adjusting bolt C.

### Caution

- If the belt is replaced with a new one or the belt has been on a running engine for less than 5 minutes, adjust deflection or tension to “New” specification.
- If the belt has been on a running engine for more than 5 minutes, adjust deflection or tension to “Used” specification.

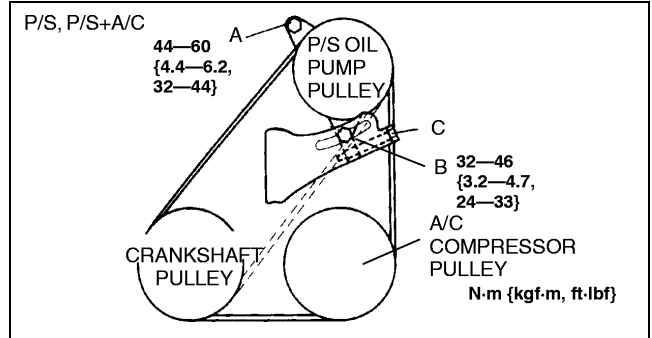

X3U110WF4

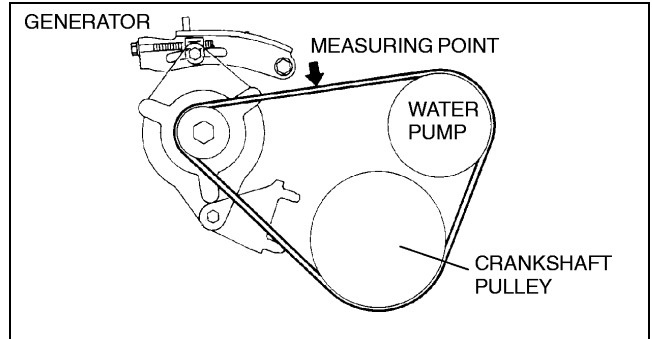

X3U110WF0

### Deflection

mm {in}

Drive belt	New	Used
Generator	6.5—7.5 {0.26—0.29}	7.0—9.0 {0.28—0.35}
P/S, P/S+A/C	7.5—9.0 {0.30—0.35}	8.0—9.5 {0.32—0.37}

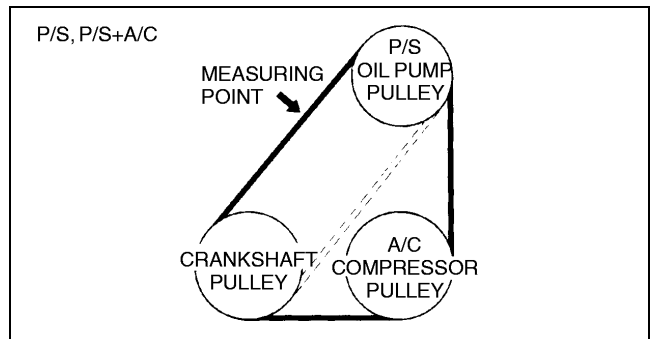

X3U110WF1

## MECHANICAL [FS]

### Tension

Drive belt	N {kgf, lbf}	
	New	Used
Generator	690—830 {70—85, 160—180}	500—680 {50—70, 110—150}
P/S, P/S+A/ C	590—780 {60—80, 140—170}	500—680 {50—70, 110—150}

3. Tighten mounting bolt A and B.
4. Inspect the belt deflection or tension.
  - If not as specified, repeat from Step 1.

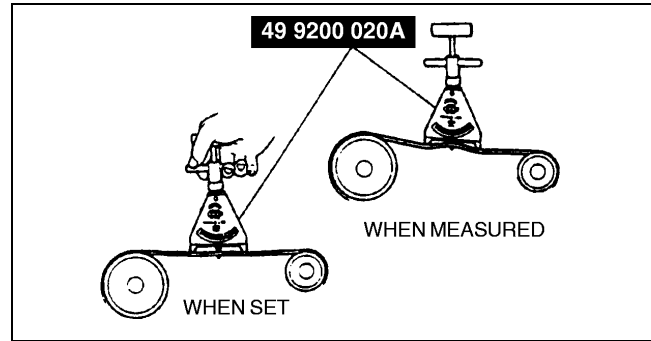

X3U110WF2

01-10B

### VALVE CLEARANCE INSPECTION [FS]

A3U011012010W01

1. Remove the cylinder head cover. (See 01-10B-10 Cylinder Head Cover Removal Note.)
2. Verify that the engine is in cold condition.
3. Measure the valve clearance.
  - (1) Turn the crankshaft clockwise so that the No.1 piston is at TDC of the compression stroke.

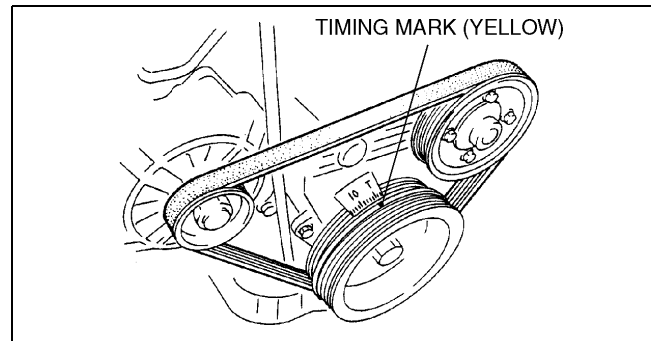

Y3U110WAC

- (2) Measure the valve clearance at A in the figure.

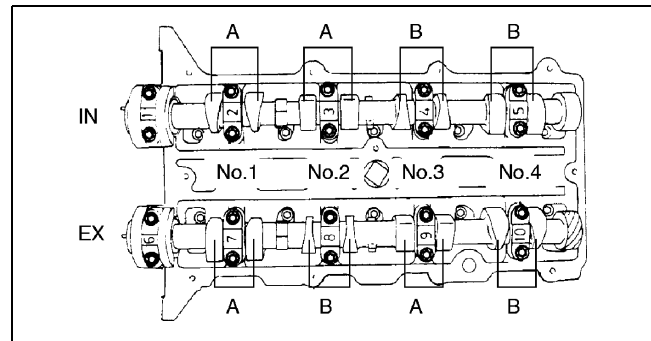

X3U110WF6

- If the valve clearance exceeds the standard, replace the adjustment shim. (See 01-10B-6 VALVE CLEARANCE ADJUSTMENT [FS].)

#### Standard [Engine cold]

**IN: 0.225—0.295 mm {0.0089—0.0116 in}**  
(0.26±0.035 mm {0.010±0.001 in})

**EX: 0.225—0.295 mm {0.0089—0.0116 in}**  
(0.26±0.035 mm {0.010±0.001 in})

- (3) Turn the crankshaft 360° clockwise so that the No.4 piston is at TDC of the compression stroke.

- (4) Measure the valve clearance at B in the figure.

- If the valve clearance exceeds the standard, replace the adjustment shim. (See 01-10B-6 VALVE CLEARANCE ADJUSTMENT [FS].)

#### Standard [Engine cold]

**IN: 0.225—0.295 mm {0.0089—0.0116 in} (0.26±0.035 mm {0.010±0.001 in})**  
**EX: 0.225—0.295 mm {0.0089—0.0116 in} (0.26±0.035 mm {0.010±0.001 in})**

4. Install the cylinder head cover. (See 01-10B-13 Cylinder Head Cover Installation Note.)

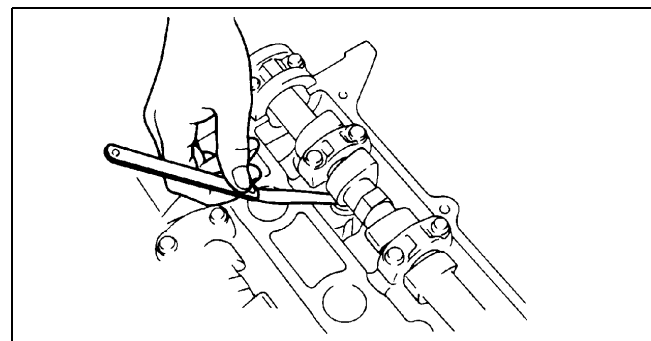

X3U110WF7

# MECHANICAL [FS]

A3U011012010W02

## VALVE CLEARANCE ADJUSTMENT [FS]

Perform this same procedure for all camshafts requiring valve clearance adjustment.

1. Turn the crankshaft clockwise so that the cams on the camshaft requiring valve clearance adjustment are positioned straight up.
2. Remove the camshaft cap bolts as necessary.

### Note

- Remove only one pair of cap bolts at a time.
- Reinstall the cap bolts before removing the next pair.
  - A: For EX side No.1, 2, 3 cylinder adjustment shim removal.
  - B: For IN side No.1, 2, 3 cylinder adjustment shim removal.
  - C: For EX side No.2, 3, 4 cylinder adjustment shim removal.
  - D: For IN side No.2, 3, 4 cylinder adjustment shim removal.

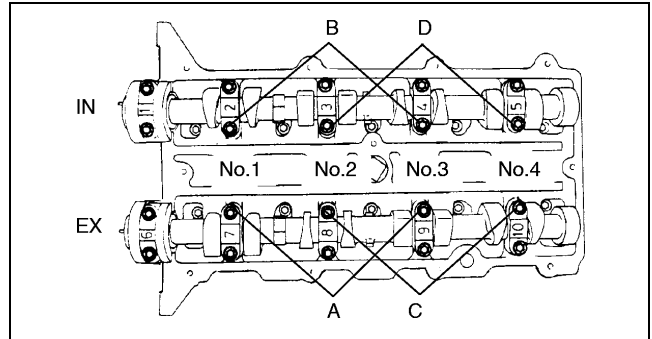

X3U110WF8

### Note

- For EX side No.2, 3 cylinder adjustment shim removal, remove bolts either A or C.
- For IN side No.2, 3 cylinder adjustment shim removal, remove bolts either B or D.

3. Install the **SSTs** on the camshaft using the camshaft cap bolt holes.

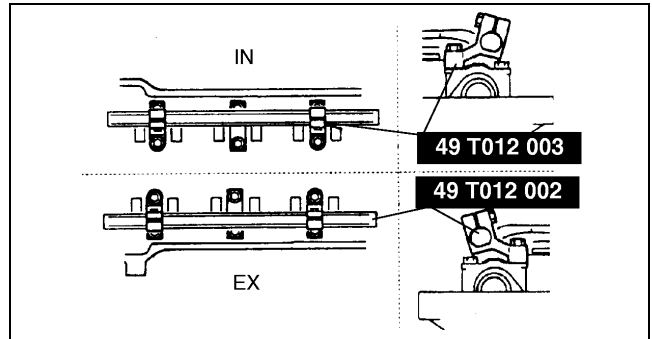

X3U110WF9

### Tightening torque

11.3—14.2 N·m {115—145 kgf·cm, 100—125 in·lbf}

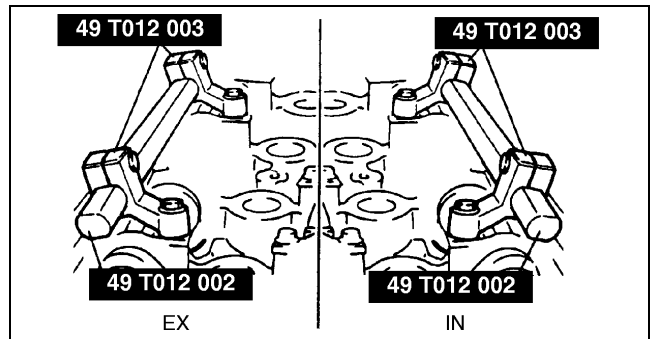

X3U110WFA

4. Align the marks on the **SSTs** (shaft and shaft clamp).
5. Tighten bolts A to secure the **SST** (shaft).

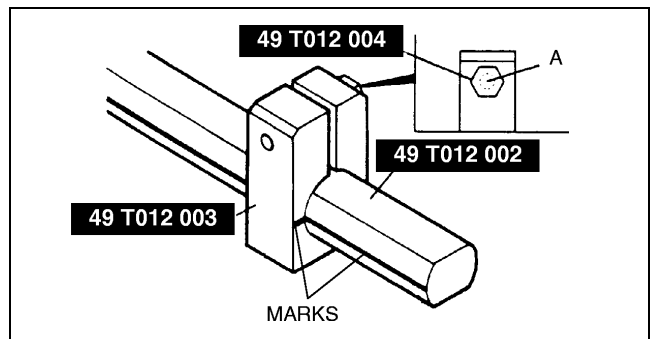

X3U110WFB

- Face the **SST** (body) outside of the cylinder head, and mount it on the **SST** (shaft) at the point of the adjustment shim to be replaced.

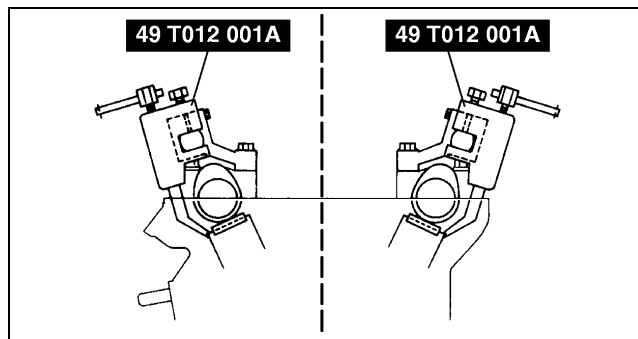

X3U110WFC

- Face the notch of the tappet so that a fine screwdriver can be inserted.
- Set the **SST** on the tappet by its notch.

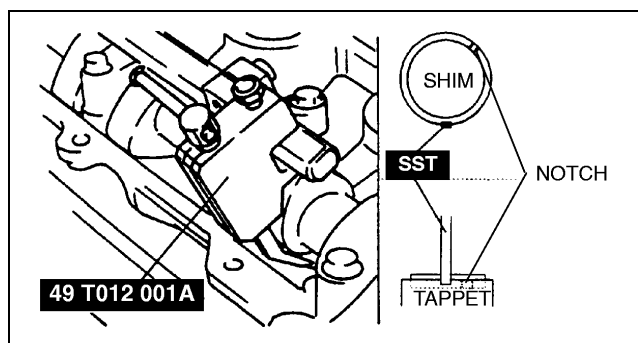

X3U110WFD

- Tighten bolt B to secure the **SST** (body).

### Caution

- Cylinder head can be damaged when the tappet is pressed down.

- Tighten bolt C, and press down the tappet.

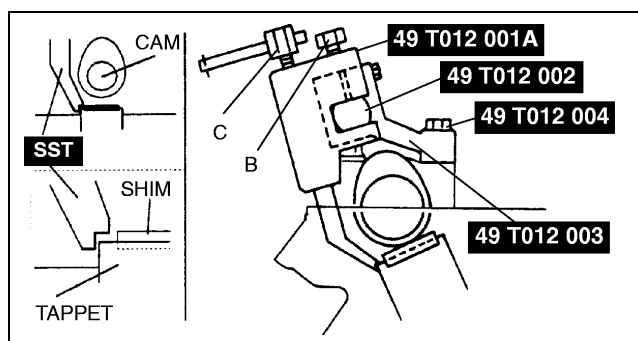

X3U110WFE

- Using a fine screwdriver, pry up the adjustment shim through the notch on the tappet. Remove the shim using a magnet.
- Select proper adjustment shim.

### New adjustment shim

$$\text{New adjustment shim} = \text{Removed shim thickness} + \text{Measured valve clearance} - \text{Standard valve clearance} \quad (0.26 \text{ mm } \{0.010 \text{ in}\})$$

- Push the selected shim into the tappet.
- Loosen bolt C to allow the tappet to move up.
- Loosen bolt B and remove the **SST** (body).
- Remove the **SSTs** and tighten the camshaft cap bolts.

### Tightening torque

$$11.3\text{--}14.2 \text{ N}\cdot\text{m} \{115\text{--}145 \text{ kgf}\cdot\text{cm}, 100\text{--}125 \text{ in}\cdot\text{lbf}\}$$

- Verify the valve clearance. (See 01-10B-5 VALVE CLEARANCE INSPECTION [FS].)

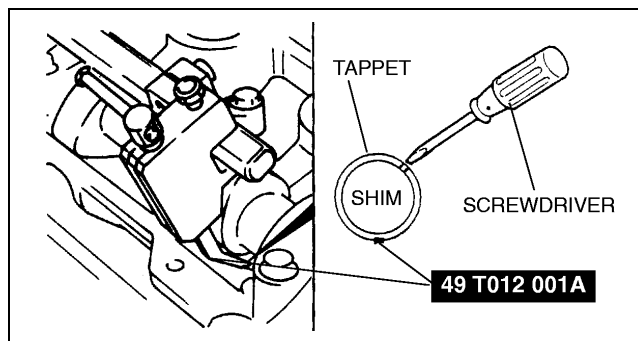

X3U110WFF



## COMPRESSION INSPECTION [FS]

A3U011002000W01

### Warning

- **Hot engines and oil can cause severe burns. Be careful not to burn yourself during removal/installation of each component.**

1. Verify that the battery is fully charged.
  - Recharge it if necessary. (See 01-17-1 BATTERY INSPECTION.)
2. Warm up the engine to the normal operating temperature.
3. Stop the engine and allow it to cool off for **about 10 min.**
4. Perform "Fuel Line Safety Procedures". Leave the fuel pump relay removed. (See 01-14-4 BEFORE REPAIR PROCEDURE.)
5. Remove the ignition coils. (See 01-18-1 IGNITION COIL REMOVAL/INSTALLATION.)
6. Remove the spark plugs.
7. Connect a compression gauge into the No.1 spark plug hole.
8. Fully depress the accelerator pedal and crank the engine.
9. Note the maximum gauge reading.
10. Inspect each cylinder as above.
  - If the compression in one or more cylinders is low or the compression difference between cylinders exceeds the maximum, pour a small amount of clean engine oil into the cylinder and recheck the compression.
    - If the compression increases, the piston, the piston rings, or cylinder wall may be worn and overhaul is required.
    - If the compression stays low, a valve may be stuck or improperly seated and overhaul is required.
    - If the compression in adjacent cylinders stays low, the cylinder head gasket may be damaged or the cylinder head distorted and overhaul is required.

### Compression

Item	kPa {kgf/cm <sup>2</sup> , psi} [rpm]
	Engine type
	FS
Standard	1,177 {12.0, 171} [300]
Minimum	824 {8.4, 119} [300]
Maximum difference between cylinders	196 {2.0, 28}

1. Disconnect the compression gauge.
2. Install the spark plugs.

### Tightening torque

**15—22 N·m {1.5—2.3 kgf·m, 11—16 ft·lbf}**

3. Connect the ignition coil connector.
4. Install the fuel pump relay.

## TIMING BELT REMOVAL/INSTALLATION [FS]

A3U011012040W01

1. Disconnect the negative battery cable.
2. Remove the CMP sensor and CKP sensor. (See 01-40B-34 CAMSHAFT POSITION (CMP) SENSOR REMOVAL/INSTALLATION [FS].) (See 01-40B-34 CRANKSHAFT POSITION (CKP) SENSOR REMOVAL/INSTALLATION [FS].)
3. Remove the ignition coils. (See 01-18-1 IGNITION COIL REMOVAL/INSTALLATION.)
4. Remove the spark plug.
5. Remove in the order indicated in the table.
6. Install in the reverse order of removal.
7. Inspect the air gap. (See 01-40B-32 Air Gap Inspection.)
8. Adjust the drive belt deflection/tension. (See 01-10B-4 DRIVE BELT ADJUSTMENT [FS].)
9. Start the engine and:
  - (1) Inspect the pulleys and drive belt for runout and contact.
  - (2) Inspect the ignition timing. (See 01-10B-25 Ignition Timing Inspection.)

# MECHANICAL [FS]

01-10B

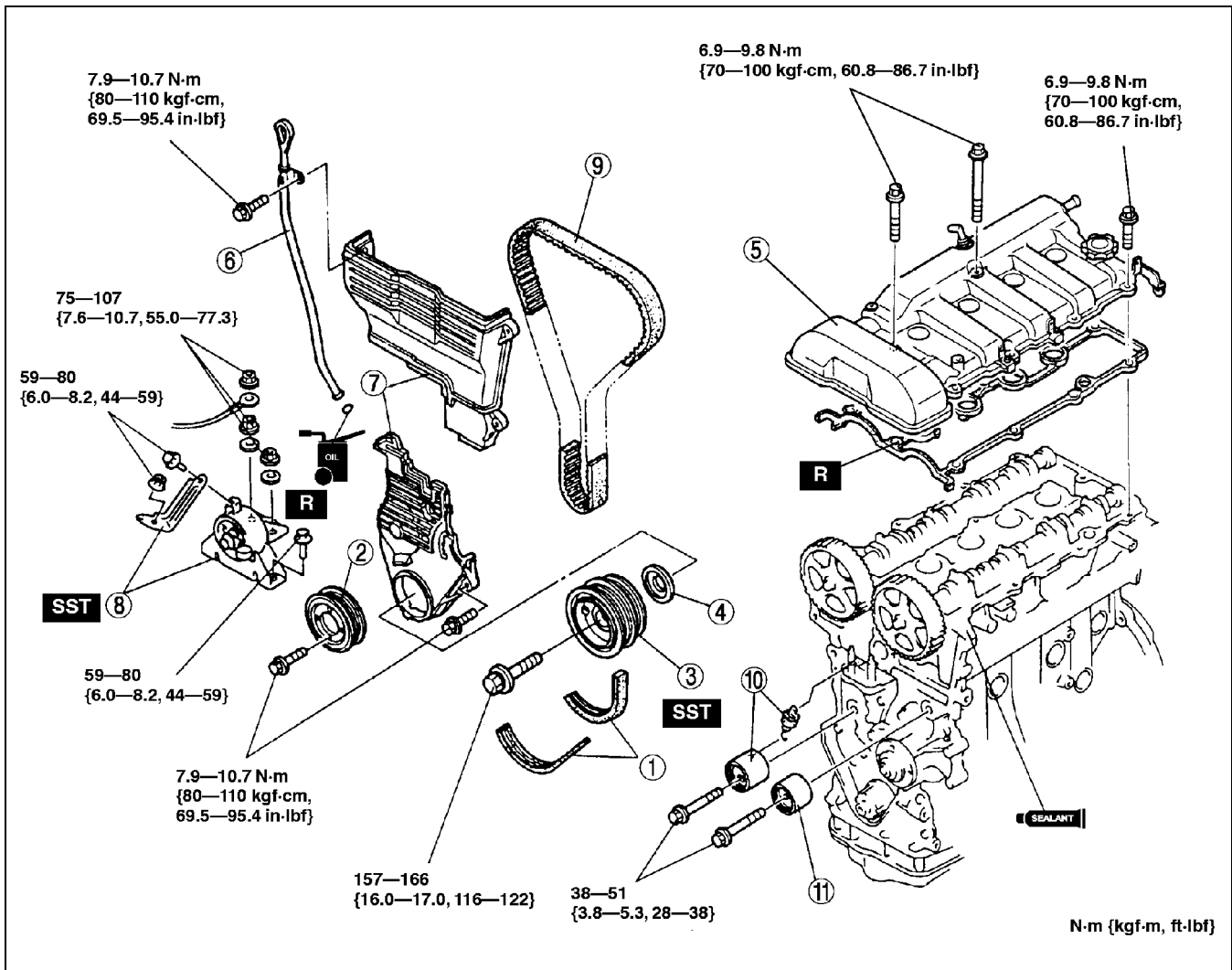

Y3U110WAD

1	Drive belt (See 01-10B-4 DRIVE BELT ADJUSTMENT [FS])
2	Water pump pulley (See 01-10B-14 Water Pump Pulley Installation Note)
3	Crankshaft pulley (See 01-10B-10 Crankshaft Pulley Removal Note) (See 01-10B-14 Crankshaft Pulley Installation Note)
4	Guide plate
5	Cylinder head cover (See 01-10B-10 Cylinder Head Cover Removal Note) (See 01-10B-13 Cylinder Head Cover Installation Note)
6	Dipstick and pipe

7	Timing belt cover
8	No.3 Engine mount rubber (See 01-10B-10 No.3 Engine Mount Rubber Removal Note)
9	Timing belt (See 01-10B-10 Timing Belt Removal Note) (See 01-10B-12 Timing Belt Installation Note)
10	Tensioner, tensioner spring (See 01-10B-11 Tensioner, Tensioner Spring Installation Note)
11	Idler

## MECHANICAL [FS]

### Crankshaft Pulley Removal Note

1. Remove the crankshaft using the SST.

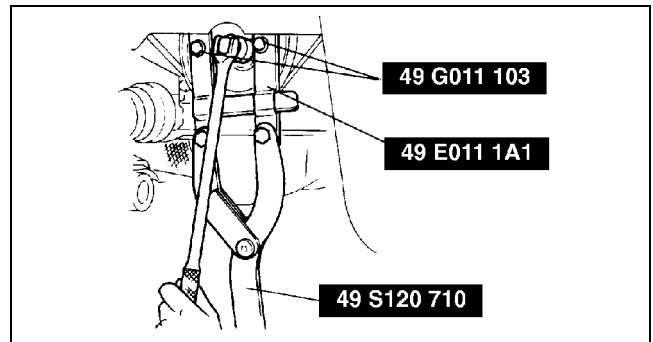

X3U110WFH

### Cylinder Head Cover Removal Note

1. Remove the cylinder head cover bolts a few turns in the order shown.

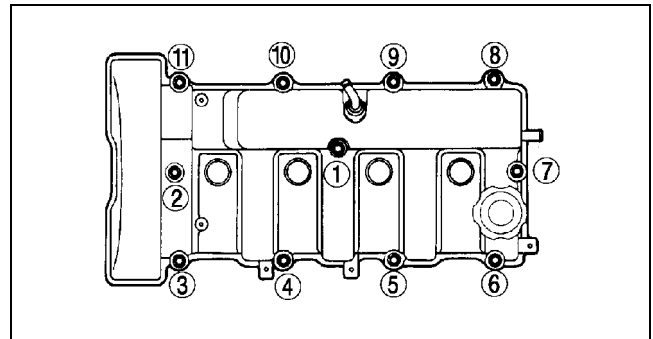

X3U110WFJ

### No.3 Engine Mount Rubber Removal Note

1. Suspend the engine using the SST.

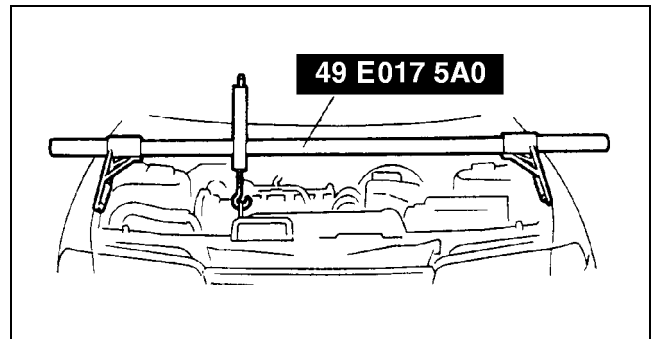

Z3U110WFK

### Timing Belt Removal Note

1. Install the pulley lock bolt.
2. Turn the crankshaft clockwise and align the timing marks.

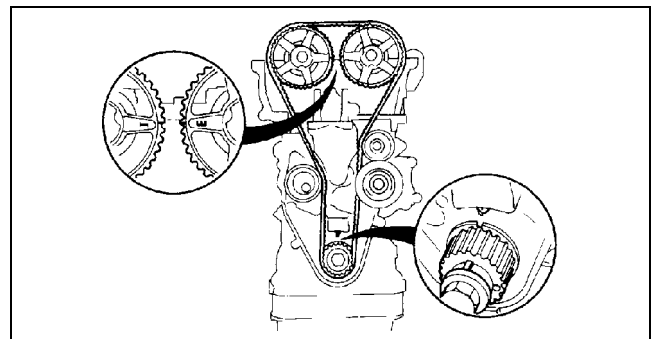

X3U110WFL

3. Turn the tensioner clockwise using an Allen wrench.
4. Disconnect the tensioner spring from the hook pin.

**Caution**

- Forcefully twisting the timing belt turning it inside out, or allowing oil or grease on it will damage the belt and shorten its life.

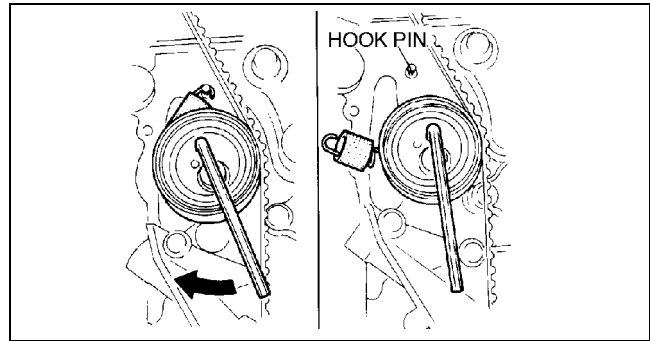

X3U110WFM

**Note**

- Mark the timing belt rotation on the belt for proper reinstallation.

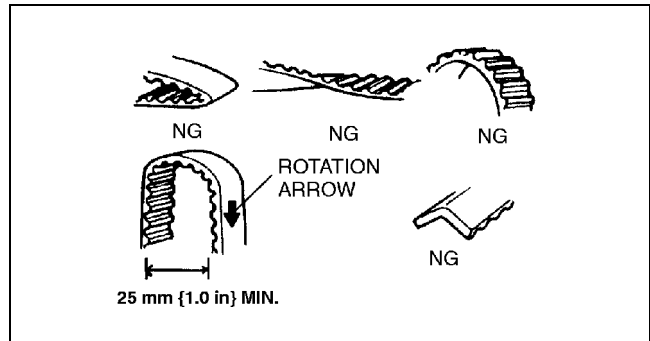

X3U110WFN

**Tensioner, Tensioner Spring Installation Note**

1. Measure the tensioner spring free length.
  - If not within the specification, replace the tensioner spring.

**Free length**  
**36.6 mm {1.44 in}**

2. Install the tensioner.

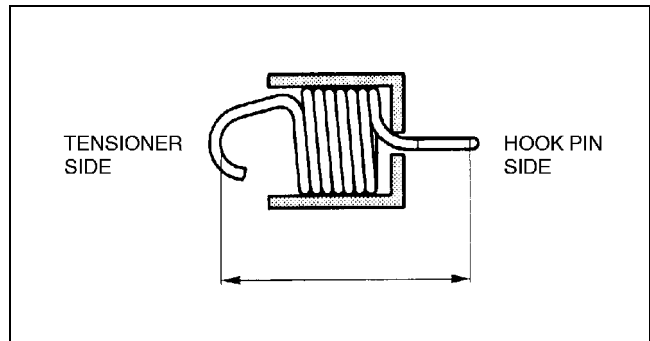

X3U110WFP

3. Rotate the tensioner.
  - If tensioner rotates with no resistance or does not rotate, replace the tensioner.

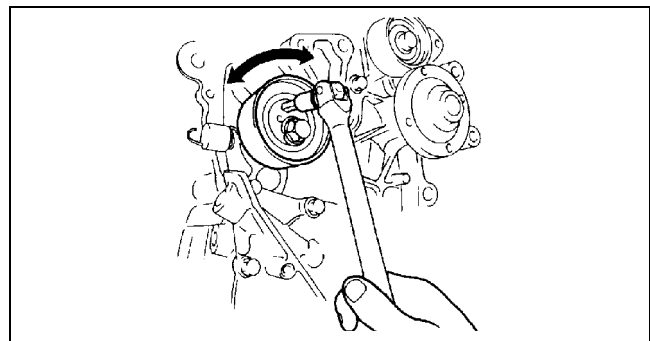

X3U110WFQ

## MECHANICAL [FS]

### Timing Belt Installation Note

1. Verify that the timing belt pulley mark and camshaft pulley marks are aligned with the timing marks as shown.

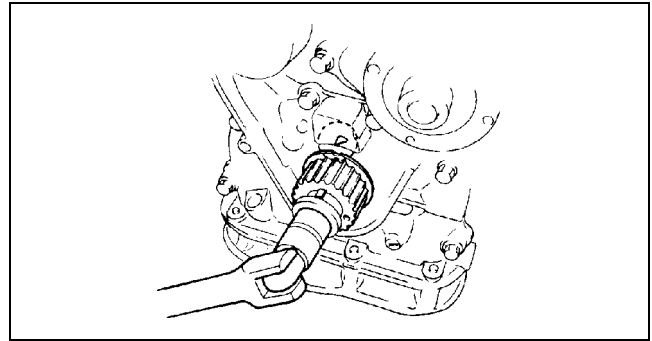

X3U110WFR

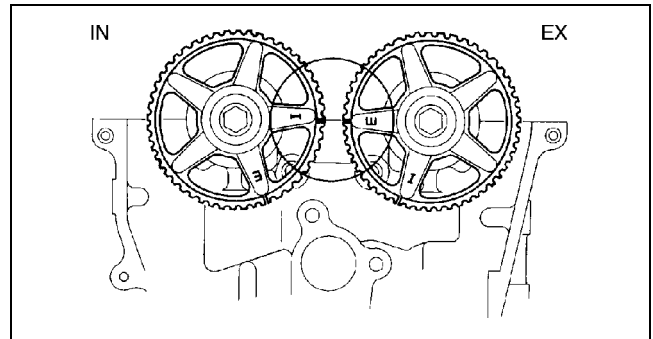

X3U110WFS

2. Install the timing belt so that there is no looseness at the idler side.

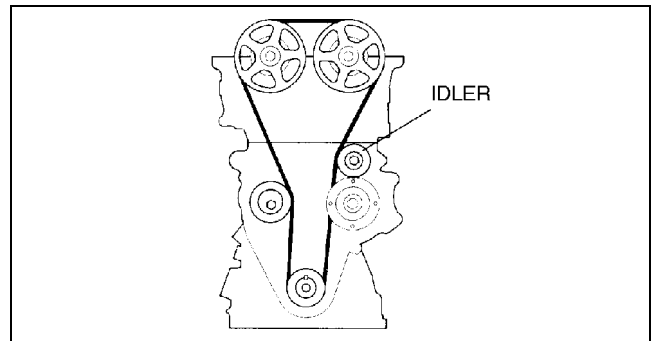

X3U110WFT

3. Turn the crankshaft clockwise twice, and align the timing marks.
4. Verify that all timing marks are correctly aligned.
  - If not aligned, remove the timing belt and repeat from Step 1.

### Caution

- Be sure not to apply tension other than that of the tensioner spring.

5. Turn the tensioner clockwise using an Allen wrench.

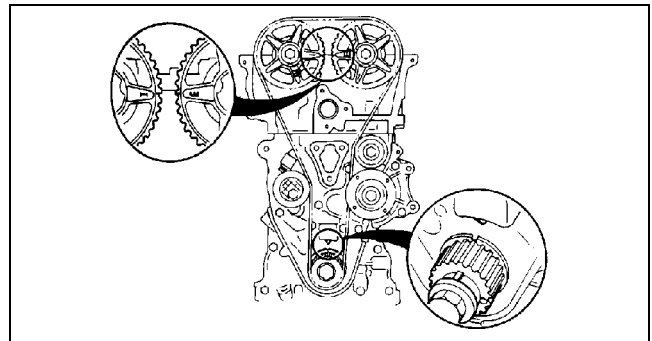

X3U110WFU

6. Connect the tensioner to the hook pin.

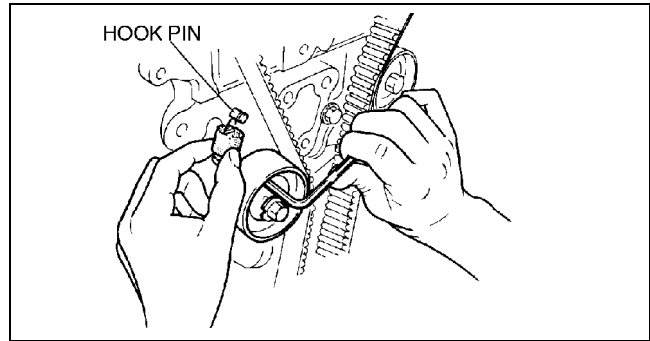

X3U110WFV

7. Turn the crankshaft clockwise twice, and verify that all timing marks are aligned.

- If not aligned, repeat from Step 1.

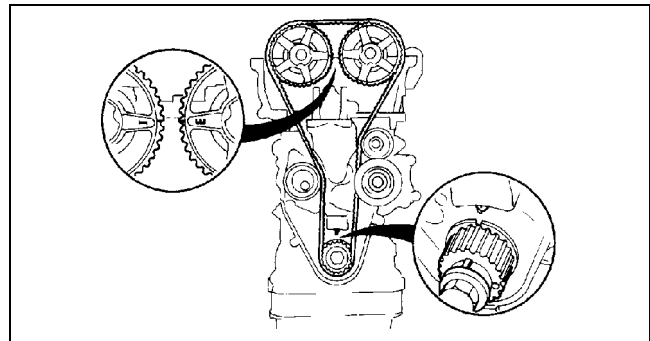

X3U110WFL

### Cylinder Head Cover Installation Note

1. Verify that the grooves on the cylinder head cover are free of oil, water and other foreign material.
2. Install the cylinder head cover gasket into the cylinder head cover.
3. Apply silicone sealant to the cylinder head as shown.

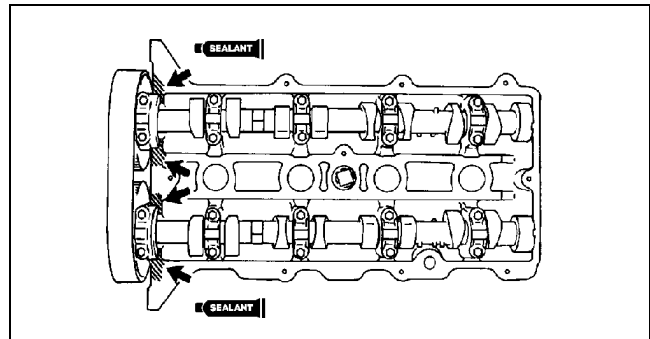

Z3U110WFW

4. Tighten the cylinder head cover bolts in the order shown.

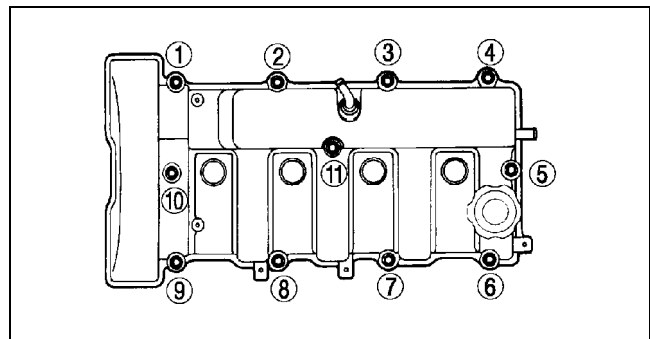

X3U110WFX

## MECHANICAL [FS]

### Crankshaft Pulley Installation Note

1. Install the crankshaft using the **SST**.

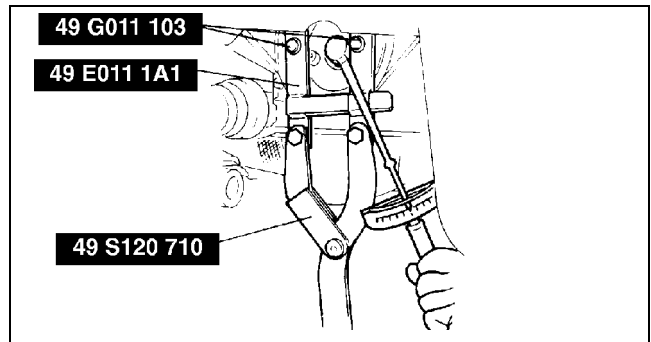

X3U110WFY

### Water Pump Pulley Installation Note

1. Install the water pump pulley by facing the “F” marks outward.

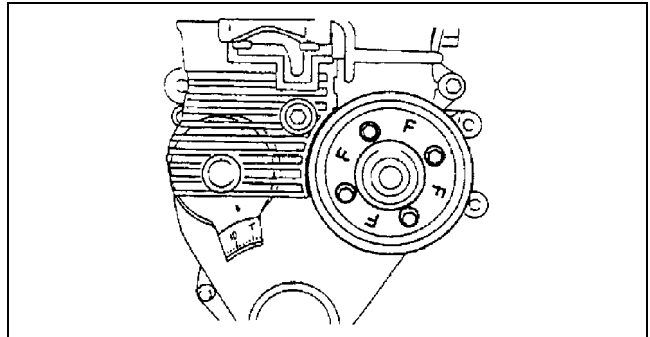

X3U110WGL

## CYLINDER HEAD GASKET REPLACEMENT [FS]

A3U011010271W01

### Warning

- Fuel vapor is hazardous. It can very easily ignite, causing serious injury and damage. Always keep sparks and flames away from fuel.
- Fuel line spills and leakage are dangerous. Fuel can ignite and cause serious injuries or death and damage. Fuel can also irritate skin and eyes. To prevent this, always complete the “Fuel Line Safety Procedures”. (See 01–14–4 BEFORE REPAIR PROCEDURE.)

1. Disconnect the negative battery cable.
2. Drain the engine coolant. (See 01–12–2 COOLING SYSTEM SERVICE WARNINGS.) (See 01–12–3 ENGINE COOLANT REPLACEMENT.)
3. Remove the timing belt. (See 01–10B–8 TIMING BELT REMOVAL/INSTALLATION [FS].)
4. Remove the front pipe. (See 01–15–1 EXHAUST SYSTEM REMOVAL/INSTALLATION.)
5. Remove the air cleaner.
6. Remove the P/S oil pump and bracket with the oil hose still connected.
7. Remove the accelerator cable. (See 01–13B–17 ACCELERATOR CABLE ADJUSTMENT [FS].)
8. Disconnect the fuel hose. (See 01–14–4 BEFORE REPAIR PROCEDURE.) (See 01–14–4 BEFORE REPAIR PROCEDURE.)
9. Remove in the order indicated in table.
10. Install in the reverse order of removal.
11. Inspect the engine oil level. (See 01–11–2 ENGINE OIL INSPECTION.)
12. Inspect for the engine oil, engine coolant, and fuel leakage.
13. Inspect the compression. (See 01–10B–8 COMPRESSION INSPECTION [FS].)
14. Start the engine and:
  - (1) Inspect the pulleys and the drive belt for runout and contact.
  - (2) Inspect the ignition timing. (See 01–10B–25 Ignition Timing Inspection.)
  - (3) Inspect the idle speed. (See 01–10B–26 Idle Speed Adjustment.)

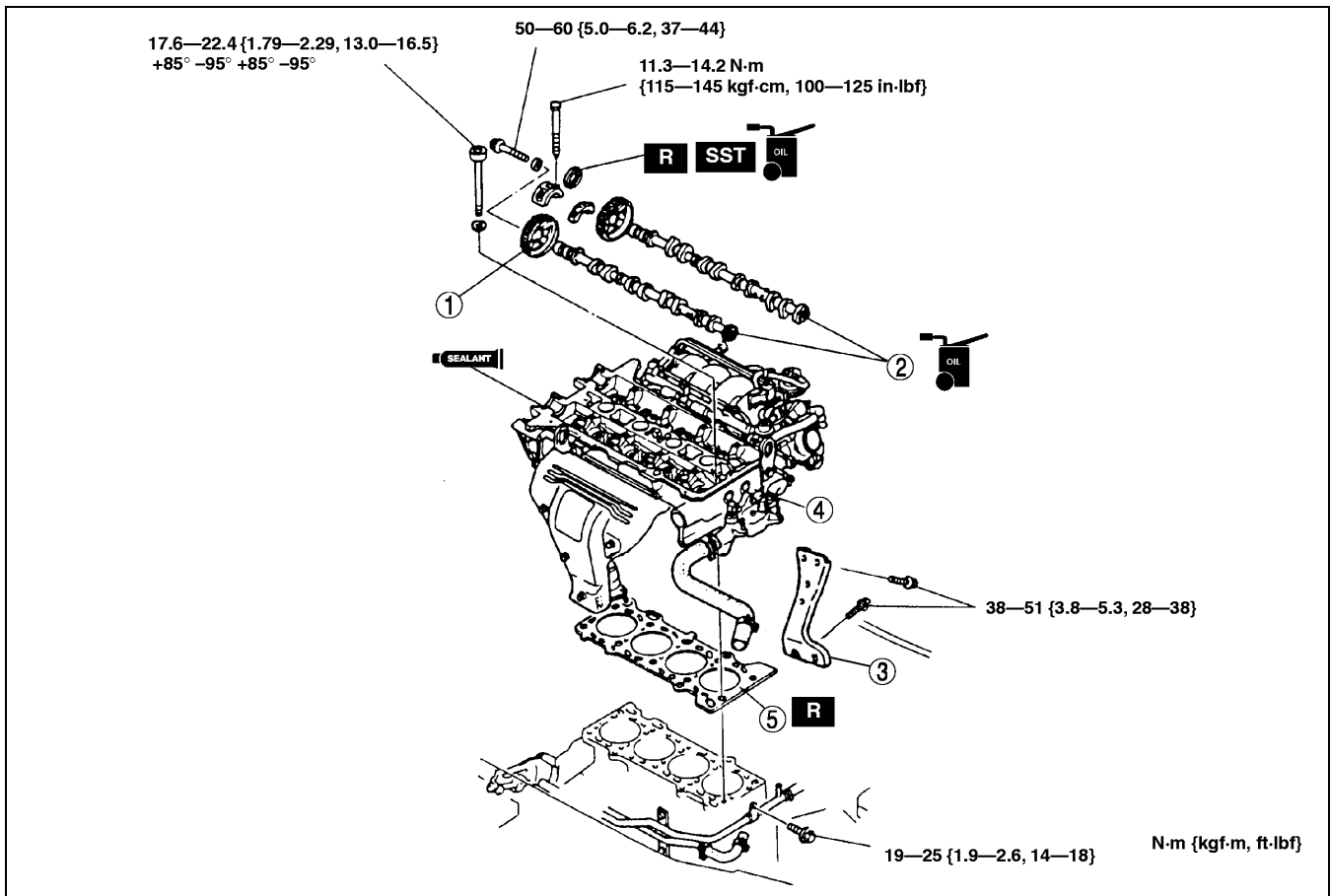

Y3U110WA6

1	Camshaft pulley (See 01-10B-15 Camshaft Pulley Removal Note) (See 01-10B-18 Camshaft Pulley Installation Note)
2	Camshaft (See 01-10B-16 Camshaft Removal Note) (See 01-10B-17 Camshaft Installation Note)
3	Intake manifold bracket

4	Cylinder head (See 01-10B-16 Cylinder Head Removal Note) (See 01-10B-16 Cylinder Head Installation Note)
5	Cylinder head gasket

### Camshaft Pulley Removal Note

1. Hold the camshaft using a wrench on the cast hexagon as shown.

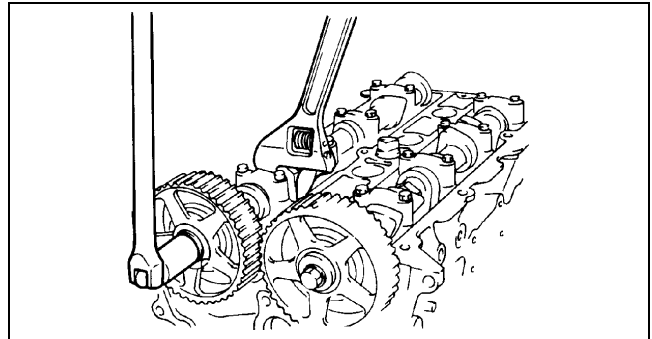

X3U110WG0



## Camshaft Removal Note

1. Loosen the camshaft cap bolts a few turns in the order shown.

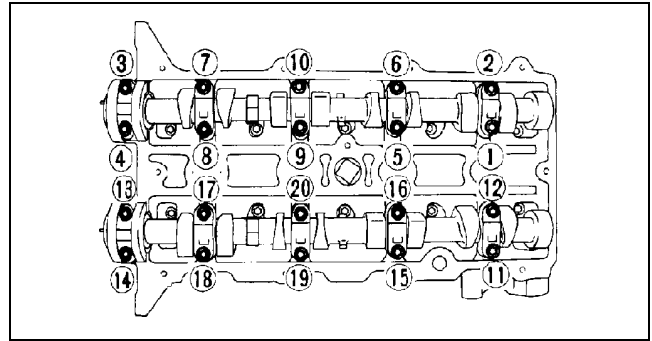

Z3U110WG1

## Cylinder Head Removal Note

1. Loosen the cylinder head bolts a few turns in the order shown.

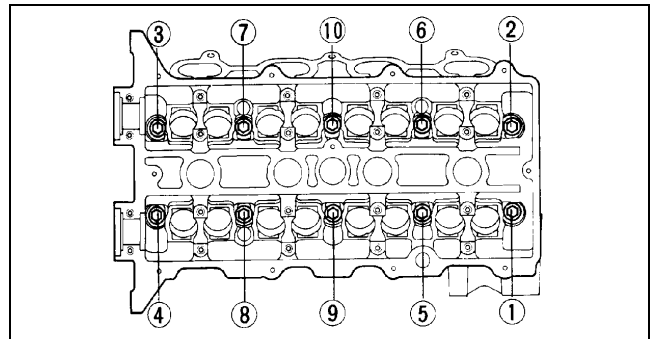

X3U110WG2

## Cylinder Head Installation Note

1. Measure the length of each bolt. Replace any that exceed the maximum length.

### Standard length

104.2—104.8 mm {4.103—4.125 in}

### Maximum length

105.5 mm {4.153 in}

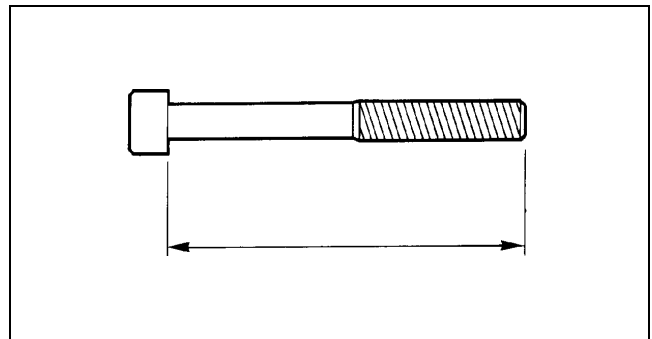

X3U110WG3

2. Tighten the cylinder head bolts a few turns in the order shown.

### Tightening torque

17.5—22.5 N·m {1.79—2.29 kgf·m, 13.0—16.5 ft·lbf}

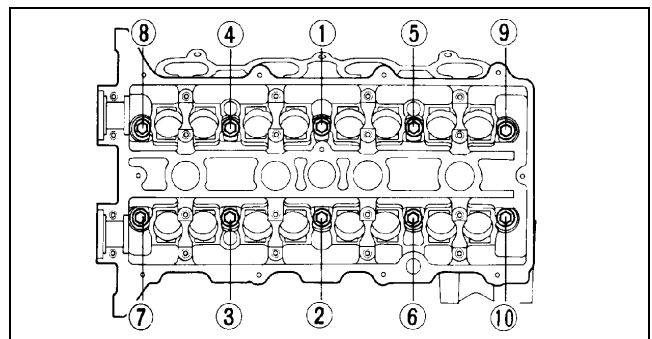

X3U110WG4

3. Put a paint mark on each bolt head.
4. Using the marks as a reference, tighten the bolts by turning each **85°—95°** in the sequence shown.
5. Further tighten each bolt by turning another **85°—95°** in the sequence shown.

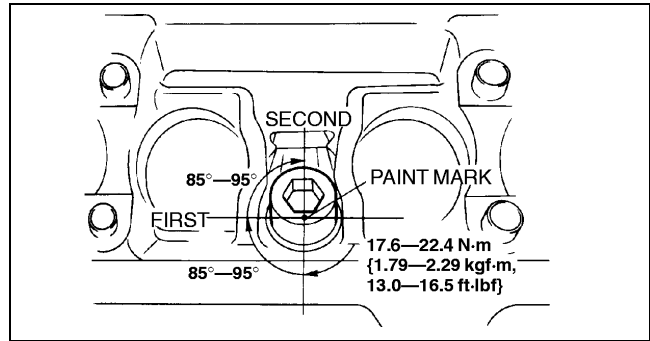

Y3U110WA7

01-10B

## Camshaft Installation Note

### Caution

- Because there is little camshaft thrust clearance, the camshaft must be held horizontally while it is installed. Otherwise, excessive force will be applied to the thrust area, causing burr on the thrust receiving area of the cylinder head journal. To avoid this, the following procedure must be observed.

1. Assemble camshaft onto the cylinder head, facing the cam noses at No.1 and No.3 cylinders as shown.

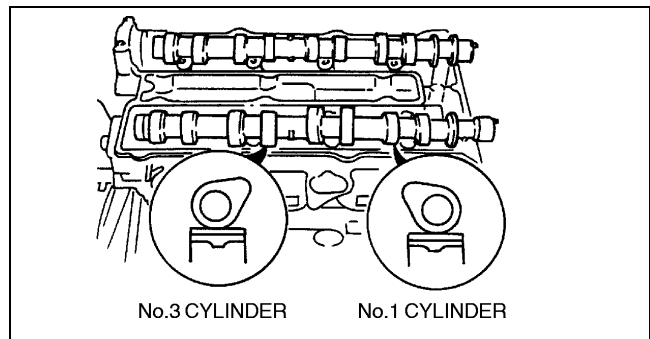

X3U110WG6

2. Apply silicone sealant to the areas shown.

### Note

- Keep the camshaft sliding surface free of sealant to prevent engine damage.

3. Apply engine oil to the camshaft and the cylinder head journals.
4. Install the camshaft caps to the positions from which they were removed.

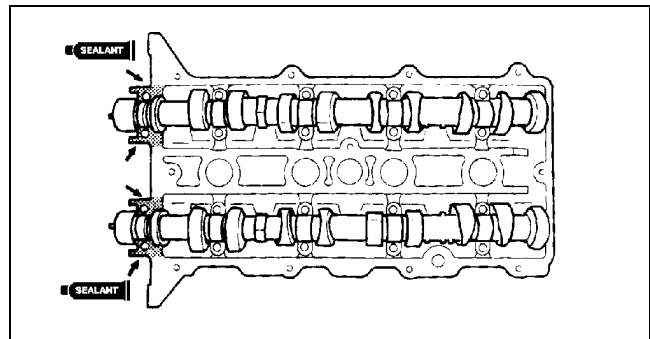

Z3U110WG7

5. Hand tighten the camshaft cap bolts marked 5, 7, 2, and 4.
6. Tighten the camshaft cap bolts a few turns in the order shown.
7. Verify that the camshaft settles horizontally when 2 bearing cap bolts at No.3 journal are tightened.
8. Apply clean engine oil to the camshaft oil seal.
9. Push the oil seal slightly in by hand.

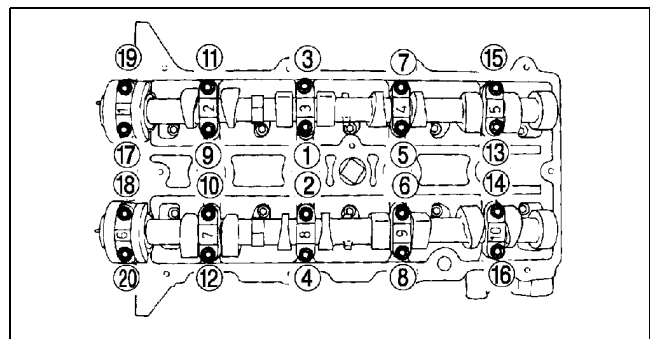

Z3U110WG8

## MECHANICAL [FS]

10. Tap the oil seals in evenly using the **SST** and a hammer.

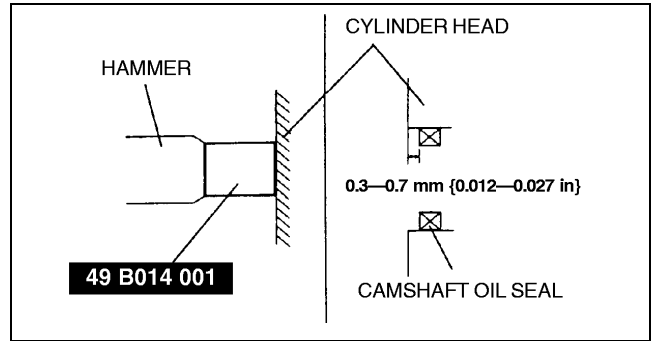

X3U110WG9

### Camshaft Pulley Installation Note

1. Install the camshaft pulleys, positioning the dowel pins as shown.

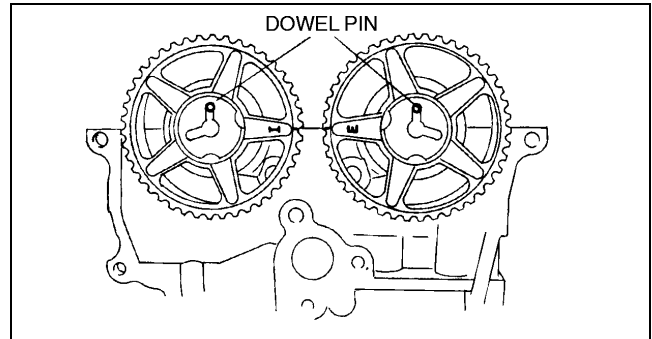

X3U110WGA

2. Hold the camshaft using a wrench on the cast hexagon as shown.

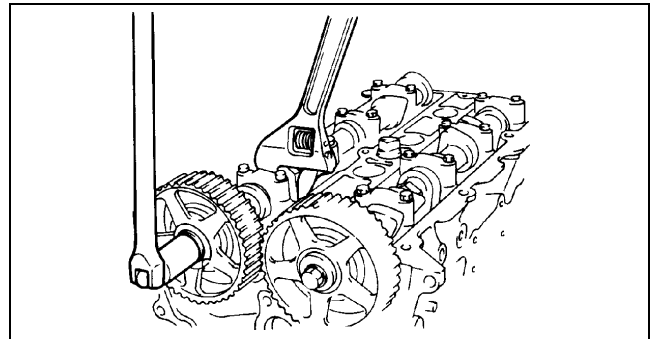

X3U110WG0

## FRONT OIL SEAL REPLACEMENT [FS]

A3U011010602W01

1. Disconnect the negative battery cable.
2. Remove the timing belt. (See 01-10B-8 TIMING BELT REMOVAL/INSTALLATION [FS].)
3. Remove in the order indicated in the table.

1	Timing belt pulley
2	Key
3	Front oil seal (See 01-10B-19 Front Oil Seal Removal Note) (See 01-10B-19 Front Oil Seal Installation Note)

4. Install in the reverse order of removal.

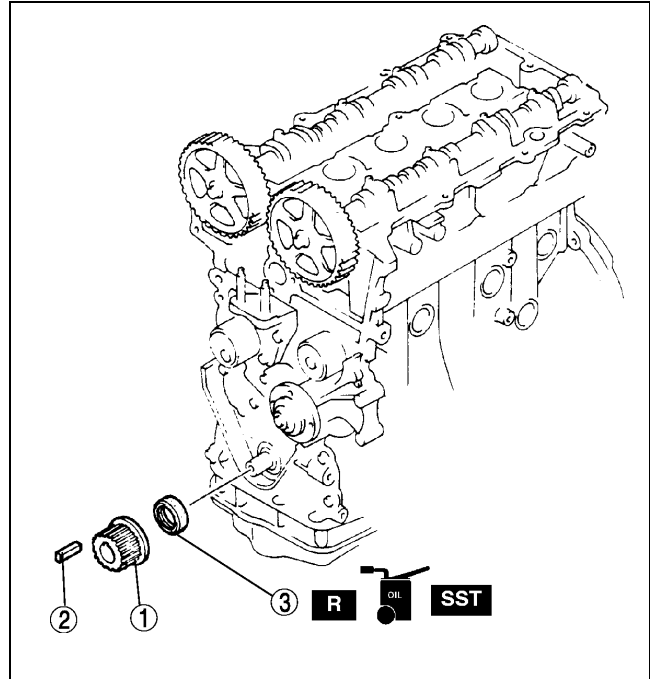

X3U110WGB

01-10B

### Front Oil Seal Removal Note

1. Cut the oil seal lip using a razor.
2. Remove the oil seal using a screwdriver protected with a rag.

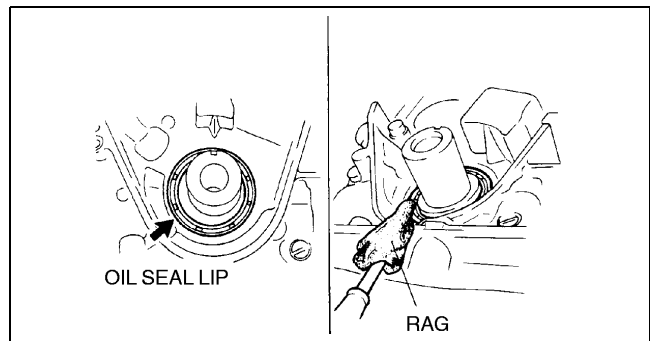

X3U110WGC

### Front Oil Seal Installation Note

1. Apply clean engine oil to the oil seal lip.
2. Push the oil seal slightly in by hand.
3. Tap the oil seal in evenly using the **SST** and a hammer.

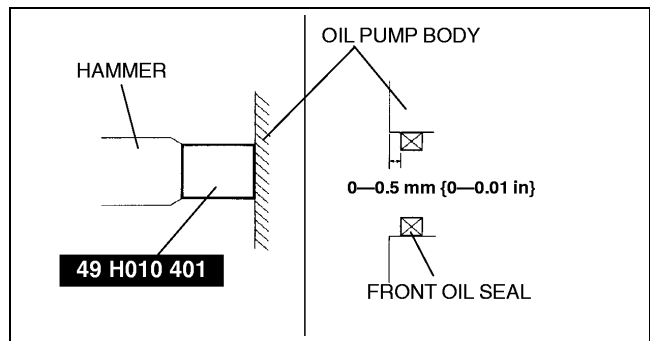

Y3U110WA8

# MECHANICAL [FS]

## REAR OIL SEAL REPLACEMENT [FS]

A3U011011399W01

1. Remove the flywheel. (MTX) (See 05-10-11 CLUTCH UNIT REMOVAL/INSTALLATION.)
2. Remove the drive plate. (ATX) (See 05-17-46 DRIVE PLATE REMOVAL/INSTALLATION.)
3. Remove in the order indicated in the table.

1	Rear oil seal (See 01-10B-20 Rear Oil Seal Removal Note) (See 01-10B-20 Rear Oil Seal Installation Note)
---	--

4. Install in the reverse order of removal.

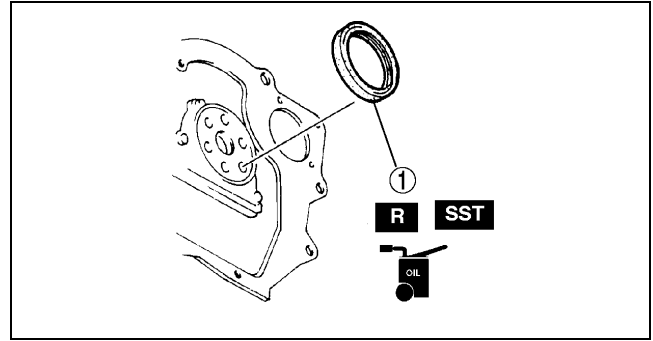

### Rear Oil Seal Removal Note

1. Cut the oil seal lip using a razor.
2. Remove the oil seal using a screwdriver protected with a rag.

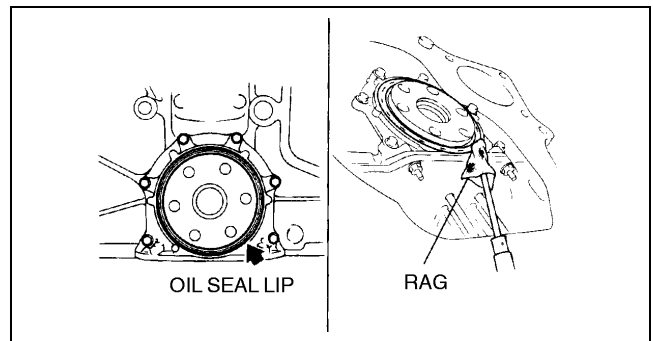

### Rear Oil Seal Installation Note

1. Apply clean engine oil to the new oil seal lip.
2. Push the oil seal slightly in by hand.
3. Tap the oil seal in evenly using the **SST** and a hammer.

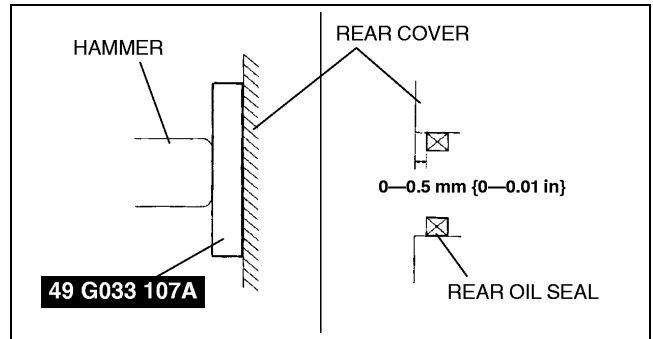

### Warning

- Fuel vapor is hazardous. It can very easily ignite, causing serious injury and damage. Always keep sparks and flames away from fuel.
- Fuel line spills and leaks are dangerous. Fuel can ignite and cause serious injuries or death and damage. Fuel can also irritate skin and eyes. To prevent this, always complete the “Fuel Line Safety Procedures”.

1. Disconnect the negative battery cable.
2. Drain the engine coolant. (See 01-12-2 COOLING SYSTEM SERVICE WARNINGS.) (See 01-12-3 ENGINE COOLANT REPLACEMENT.)
3. Remove the radiator. (See 01-12-4 RADIATOR REMOVAL/INSTALLATION.)
4. Remove the air cleaner.
5. Remove the accelerator cable. (See 01-13B-17 ACCELERATOR CABLE INSPECTION [FS].) (See 01-13B-17 ACCELERATOR CABLE ADJUSTMENT [FS].)
6. Disconnect the fuel hose. (See 01-14-4 BEFORE REPAIR PROCEDURE.) (See 01-14-5 AFTER REPAIR PROCEDURE.)
7. Remove the front pipe. (See 01-15-1 EXHAUST SYSTEM REMOVAL/INSTALLATION.)
8. Remove the rods, cables and pipes related to the transaxle.
9. Remove the battery.
10. Remove the fuse box.
11. Remove the P/S oil pump with the oil hose still connected. Position the P/S oil pump so that it is out of the way.
12. Remove the A/C compressor with the pipe still connected. position the A/C compressor so that it is out of the way.
13. Remove the drive shaft. (See 03-13-9 DRIVE SHAFT REMOVAL/INSTALLATION.)
14. Remove in the order indicated in the table.
15. Install in the reverse order of removal.
16. Start the engine and
  - (1) Inspect for the engine oil, engine coolant, transaxle oil and fuel leakage.
  - (2) Inspect the ignition timing, idle speed and idle mixture. (See 01-10B-25 Ignition Timing Inspection.) (See 01-10B-26 Idle Speed Adjustment.) (See 01-10B-26 Idle Mixture Inspection.)
17. Perform a road test.

# MECHANICAL [FS]

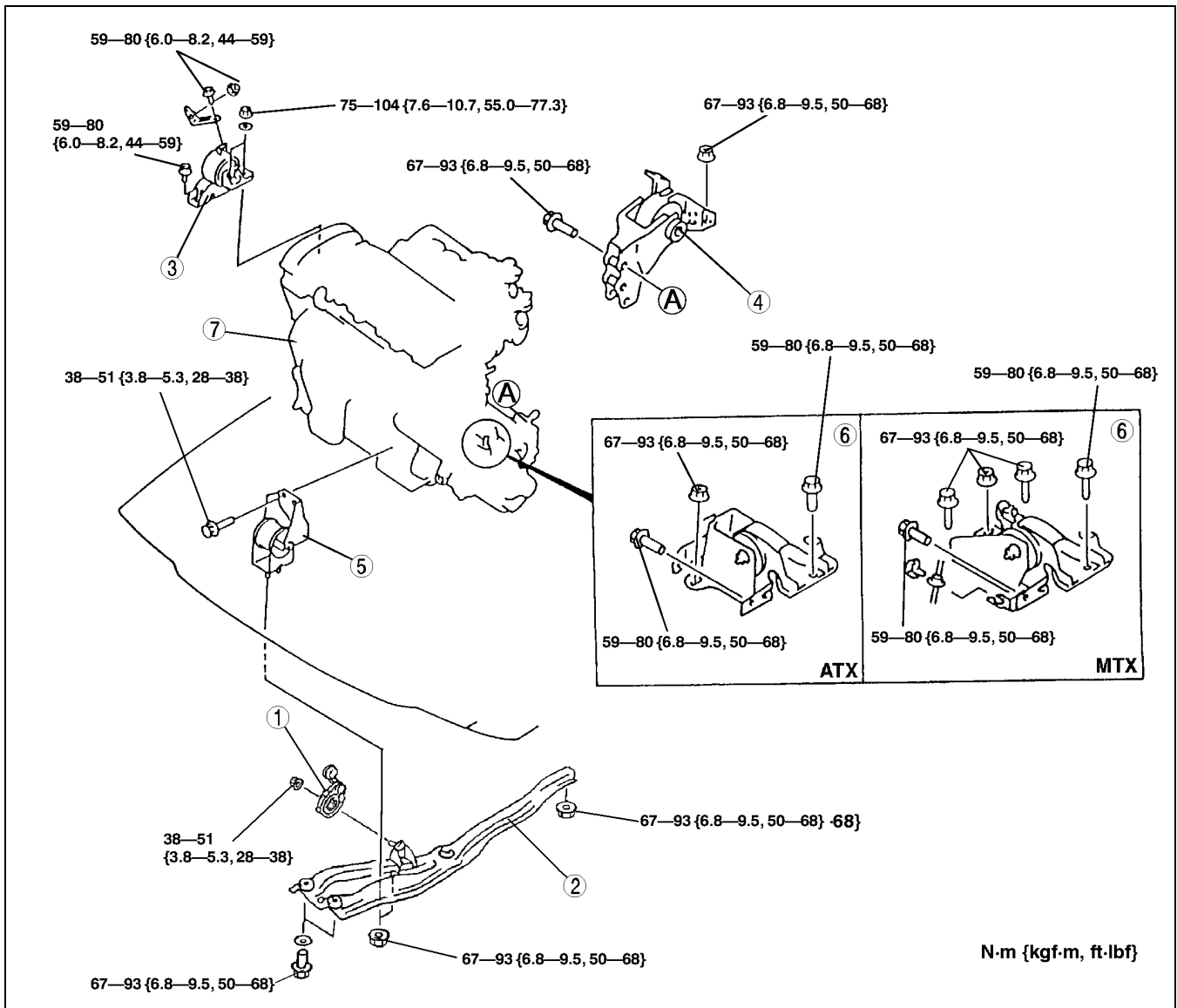

Z3U0110W997

1	Roll damper
2	Engine mount member
3	No.3 Engine mount (See 01-10B-23 No.3, No.4 Engine Mount Installation Note)
4	No.1 Engine mount

5	No.2 Engine mount
6	No.4 Engine mount (See 01-10B-23 No.3, No.4 Engine Mount Installation Note)
7	Engine, transaxle

## Roll damper Installation Note

1. Assemble the rod and roll damper as shown in the figure.

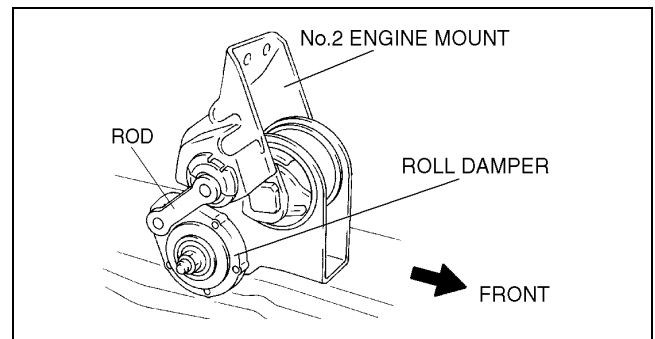

Z3U0110W991

## No.3, No.4 Engine Mount Installation Note

1. Hand tighten the No.3 and No.4 engine mount rubber bolts and nuts (A—M).
2. Tighten the No.4 engine mount rubber bolts and nuts (A—H).
3. Tighten the No.3 engine mount rubber bolts and nuts (I—N)
4. Measure the No.4 engine mount rubber clearance.
  - If not within the specification, repeat from step 1.

### Standard clearance

**3.0—4.0 mm {0.12—0.15 in}**

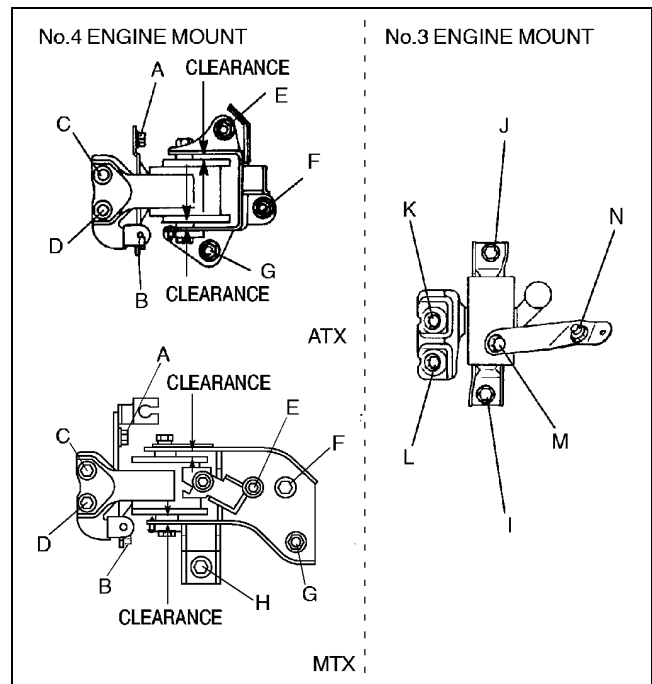

Z3U0110W996



# MECHANICAL [FS]

## ENGINE DISASSEMBLY/ASSEMBLY [FS]

A3U011002000W03

1. Disconnect the engine and transaxle. (See 05-15B-4 MANUAL TRANSAXLE (MTX) REMOVAL/INSTALLATION [G15M-R].) (See 05-17-31 AUTOMATIC TRANSAXLE (ATX) REMOVAL/INSTALLATION [FS].)
2. Remove the intake-air system. (See 01-13B-6 INTAKE-AIR SYSTEM REMOVAL/INSTALLATION [FS].)
3. Remove the exhaust system. (See 01-15-1 EXHAUST SYSTEM REMOVAL/INSTALLATION.)
4. Remove the oil filter. (See 01-11-3 OIL FILTER REPLACEMENT.)
5. Remove the thermostat. (See 01-12-5 THERMOSTAT REMOVAL/INSTALLATION.)
6. Remove the ignition coil.
7. Remove the generator.
8. Disassemble in the order indicated in the table.
9. Assemble in the reverse order of disassembly.

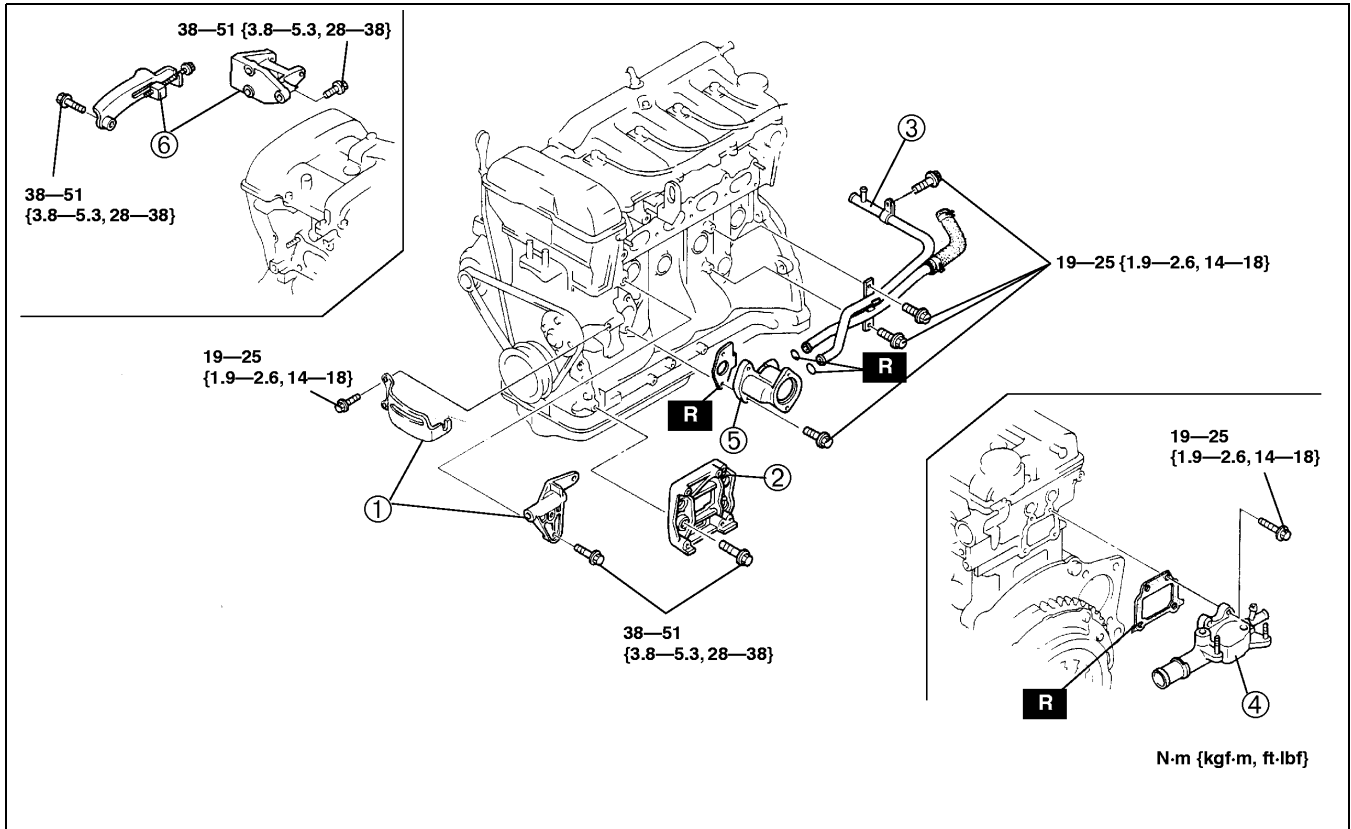

X3U110WGK

1	P/S oil pump bracket
2	A/C compressor bracket
3	Water bypass pipe

4	Water outlet
5	Thermostat housing
6	Generator bracket

## ENGINE TUNE-UP [FS]

A3U011002000W04

### Engine Tune-up Preparation

1. Warm up the engine to normal operating temperature.
2. Shift the transaxle into neutral.
3. Turn off all electrical loads.
  - Headlight switch
  - Fan switch
  - Rear window defroster switch
  - A/C switch
4. Verify that the steering wheel is at straight ahead position.
5. Connect the **SSTs** (WDS or equivalent) to the DLC-2.
6. Access RPM PID.
7. Wait until the electrical fan stops.

01-10B

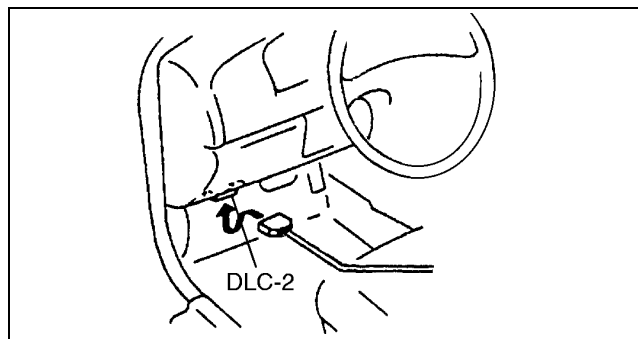

Z3U110WA5

### Ignition Timing Inspection

1. Perform "Engine Tune-up Preparation".
2. Verify that the RPM PID is within the specification.
  - If not as specified, adjust the idle speed. (See 01-10B-26 Idle Speed Adjustment.)

#### Specification

**650—750 (700±50) rpm**

3. Connect the timing light to the high-tension lead of the No.1 cylinder.
4. Verify that the timing mark (yellow) on the crankshaft pulley is within the specification.
  - If not as specified, inspect following.
    - CMP sensor
    - CKP sensor
    - TP sensor
    - ECT sensor
    - Neutral switch (MTX)
    - Clutch switch (MTX)
    - TR switch (ATX)
  - If the devices are normal, replace the PCM. (See 01-40B-7 PCM REMOVAL/INSTALLATION [FS].)

#### Ignition timing

**BTDC 9°—11° (10°±1°) (TIMING MARK [YELLOW])**

5. Connect the **SST** (System selector) to the DLC.
6. Set switch A to position 1.
7. Set the test switch to SELF TEST.

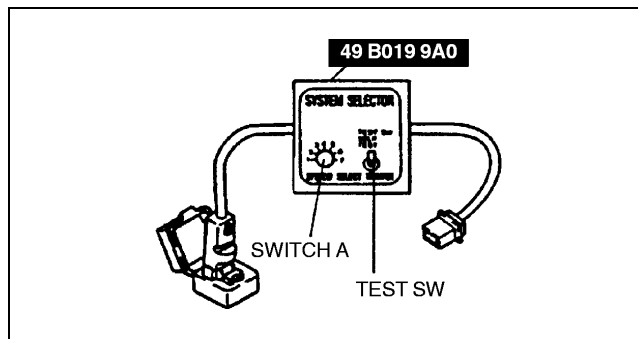

X3U110WGG

## MECHANICAL [FS]

8. Verify that the timing mark (yellow) on the crankshaft pulley is within the specification.
  - If not as specified, inspect the following.
    - CMP sensor
    - CKP sensor
    - TP sensor
    - ECT sensor
    - Neutral switch (MTX)
    - Clutch switch (MTX)
    - TR switch (ATX)
  - If the devices are normal, replace the PCM. (See 01-40B-7 PCM REMOVAL/INSTALLATION [FS].)

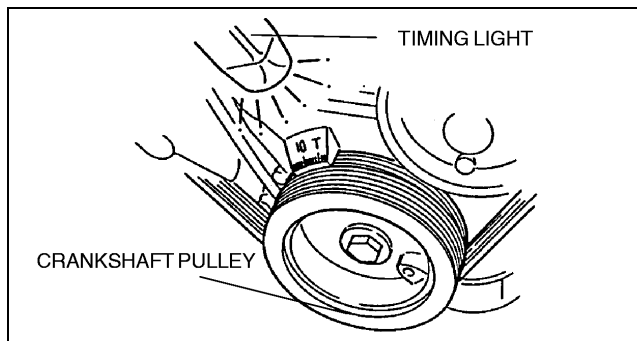

X3U110WGN

**Specification**  
BTDC 6°—18°

### Idle Speed Adjustment

1. Perform "Engine Tune-up Preparation".
2. Verify that the RPM PID is within the specification.
  - If not as specified, adjust the idle speed by turning the AAS.

**Specification**  
650—750 (700±50) rpm

### Caution

- The TAS is set at the factory and must not be adjusted. Any adjustment will negatively effect the engine performance.

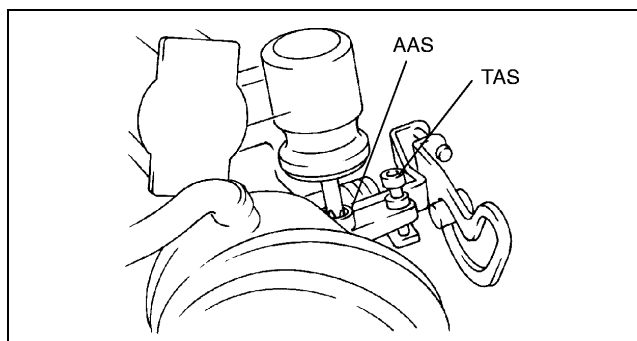

X3U110WGP

3. Connect the **SST** (System selector) to the DLC.
4. Set switch A to position 1.
5. Set the test switch to SELF TEST.
6. Press **CLEAR** to clear previously selected items.
7. Disconnect the **SSTs**.

### Idle-up Speed Inspection

1. Perform "Engine Tune-up Preparation".
2. Connect the **SST** (System selector) to the DLC.
3. Set switch A to position 1.
4. Set the test switch to SELF TEST.
5. Verify that the idle speed is normal. (See 01-10B-26 Idle Speed Adjustment.)
6. Verify that the RPM PID is within the specification.
  - If not as specified with all load conditions, inspect the IAC valve.
  - If not as specified with some load condition, inspect the related input switches, harnesses, and connectors.

### Specification

Load condition	Idle-up speed (rpm)*1
E/L ON*2	650—750
P/S operating*3	700—800
A/C ON*4	700—800

\*1 : Excludes temporary idle speed drop just after the electrical loads (E/L) are turned on.

\*2 : Headlight is on, Fan switch is above 1st, Cooling fan is operating, Rear window defroster is on.

\*3 : Steering wheel is fully turned.

\*4 : A/C switch and fan switch are on.

### Idle Mixture Inspection

1. Perform "Engine Tune-up Preparation".
2. Verify that the idle speed and ignition timing are within the specification. (See 01-10B-25 Ignition Timing Inspection.) (See 01-10B-26 Idle Speed Adjustment.)
3. Turn the test mode off.
4. Warm up the engine by holding the engine speed at **2,500—3,000 rpm** for **approx. 3 min.**
5. Insert an exhaust gas analyzer to the tailpipe.

## 01-10B-26

6. Verify that the CO and HC concentrations are within the specified limits.
  - If not within the specified limits, inspect the following:
    - On-board diagnostic system (See 01-02B-15 DTC TABLE [FS].)
    - HO2S (See 01-40B-37 HEATED OXYGEN SENSOR (HO2S) INSPECTION [FS].)
    - Intake manifold vacuum (See 01-03B-56 Intake Manifold Vacuum Inspection.)
    - Fuel line pressure (See 01-14-6 FUEL PRESSURE INSPECTION.)
    - Ignition timing control
      - If the systems and devices are normal, replace the TWC. (See 01-15-1 EXHAUST SYSTEM REMOVAL/INSTALLATION.)

# 01-11 LUBRICATION

**OIL PRESSURE INSPECTION** ..... 01-11-2  
**ENGINE OIL INSPECTION** ..... 01-11-2  
**ENGINE OIL REPLACEMENT** ..... 01-11-3  
**OIL FILTER REPLACEMENT** ..... 01-11-3  
**OIL PAN REMOVAL/INSTALLATION** .. 01-11-4  
 Oil Pan Removal Note ..... 01-11-5  
 MBSP (Main bearing support plate)  
 Removal Note ..... 01-11-6  
 MBSP (Main bearing support plate)  
 Installation Note ..... 01-11-6  
 Oil Strainer Installation Note ..... 01-11-7  
 Oil Pan Installation Note ..... 01-11-7  
 Integrated Stiffener Installation Note .. 01-11-8

**OIL PUMP REMOVAL/INSTALLATION** . 01-11-10  
 Oil Pan Upper Block Removal Note ... 01-11-11  
 Oil Pump Remova ..... 01-11-12  
 Oil Pump Installation Note ..... 01-11-12  
 Oil Pan Upper Block Installation Note . 01-11-13  
**OIL PUMP DISASSEMBLY/ASSEMBLY** . 01-11-14  
 Cotter Pin Assembly Note ..... 01-11-14  
 Inner Rotor, Outer Rotor Assembly  
 Note ..... 01-11-15  
**OIL PUMP INSPECTION** ..... 01-11-15  
 Rotor Clearance Inspection ..... 01-11-15  
 Pressure Spring Inspection ..... 01-11-16

01-11

## LUBRICATION LOCATION INDEX

A3U011101003W01

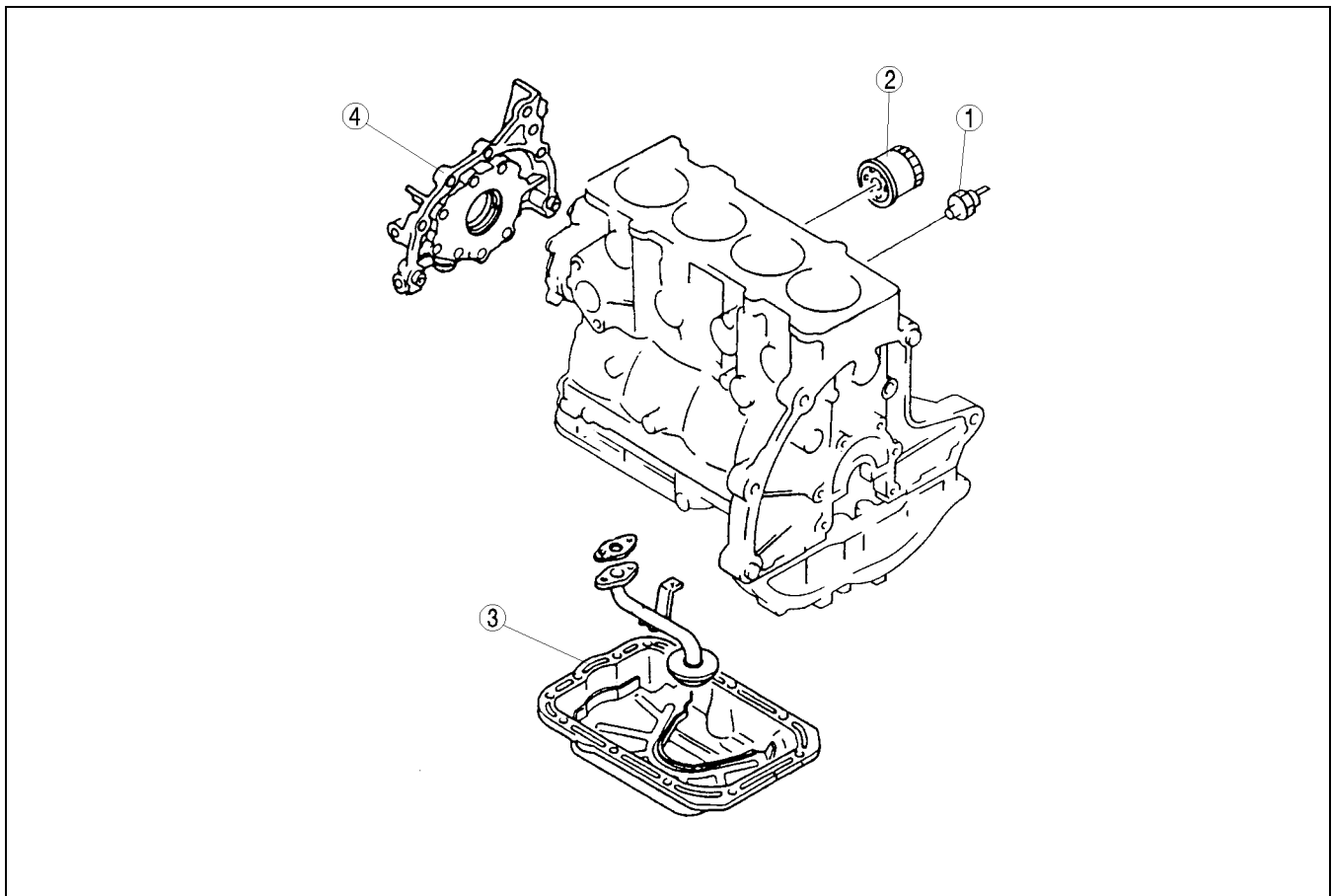

Z3U0111W100

1	Oil pressure switch (See 01-11-2 OIL PRESSURE INSPECTION)
2	Oil filter (See 01-11-3 OIL FILTER REPLACEMENT)
3	Oil pan (See 01-11-4 OIL PAN REMOVAL/ INSTALLATION)

4	Oil pump (See 01-11-10 OIL PUMP REMOVAL/ INSTALLATION) (See 01-11-14 OIL PUMP DISASSEMBLY/ ASSEMBLY) (See 01-11-15 OIL PUMP INSPECTION)
---	--

# LUBRICATION

## OIL PRESSURE INSPECTION

A3U01110200W01

### Warning

- Continuous exposure with USED engine oil has caused skin cancer in laboratory mice. Protect your skin by washing with soap and water immediately after this work.
- When the engine and the oil are hot, they can cause severe burns. Turn off the engine and wait until it and oil are cool.

1. Remove the intake manifold bracket. (FS model)
2. Remove the oil pressure switch. (ZM model)
3. Screw the **SST** into the oil pressure switch installation hole.
4. Warm up the engine to normal operating temperature.
5. Run the engine at the specified speed, and note the gauge readings.
  - If the pressure is not as specified, inspect for the cause and repair or replace as necessary.

### Note

- The oil pressure can vary with oil viscosity and temperature.

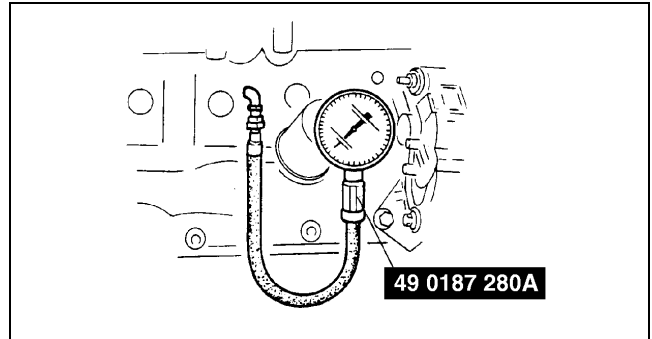

X3U111WA1

### Oil pressure

**ZM: 300—390 kPa {3.0—4.0 kgf/cm<sup>2</sup>, 43—56 psi} [3,000 rpm]**  
**FS: 400—490 kPa {4.0—5.0 kgf/cm<sup>2</sup>, 57—71 psi} [3,000 rpm]**

6. Stop the engine and wait until it is cool.
7. Remove the **SST**.
8. Apply silicone sealant to the oil pressure switch threads as shown.
9. Install the oil pressure switch.

### Tightening torque

**12—17 N·m {1.2—1.8 kgf·m, 9—13 ft·lbf}**

10. Install the intake manifold bracket. (FS model)
11. Start the engine and inspect for oil leakage.

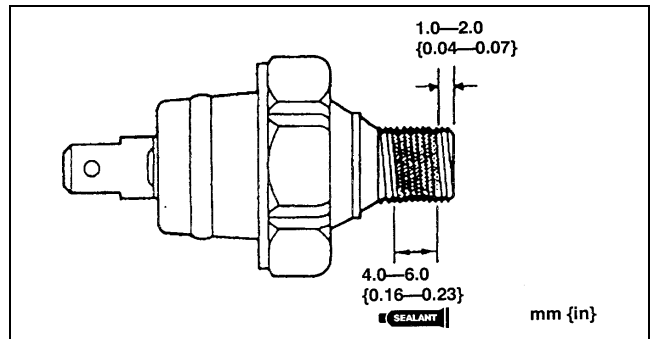

Y3U111WA0

## ENGINE OIL INSPECTION

A3U011114001W01

1. Position the vehicle on level ground.
2. Warm up the engine to normal operating temperature and stop it.
3. Wait for **5 min**.
4. Remove the dipstick and inspect for oil level and condition. Verify that the oil level is within the F and L marks on the dipstick.
  - Add or replace oil if necessary.
5. Verify that the dipstick O-ring is installed as shown, then reinstall the dipstick.

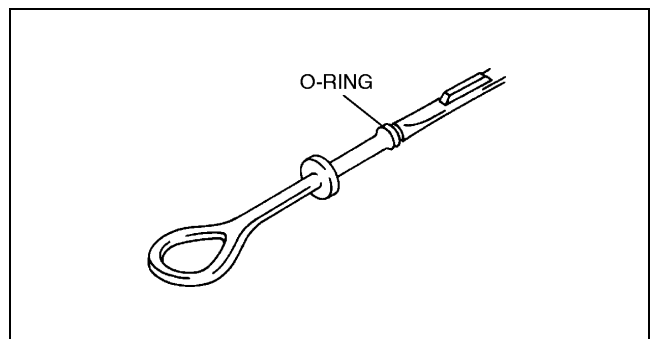

X3U111WA3

### Warning

- When the engine and the engine oil are hot, they can cause severe burns. Do not burn yourself with either.
- A vehicle that is lifted but not securely supported on safety stands is dangerous. It can slip or fall, causing death or serious injury. Never work around or under a lifted vehicle if it is not securely supported on safety stands.
- Continuous exposure with USED engine oil has caused skin cancer in laboratory mice. Protect your skin by washing with soap and water immediately after this work.

1. Position the vehicle on level ground.
2. Remove the oil filler cap and the oil pan drain plug.
3. Drain the oil into a container.
4. Install the drain plug with new washer.

### Tightening torque

**30—41 N·m {3.0—4.2 kgf·m, 22—30 ft·lbf}**

5. Refill the engine with the specified type and amount of engine oil.
6. Refit the oil filler cap.
7. Run the engine and inspect for oil leakage.
8. Inspect the oil level.
  - Add oil if necessary. (See 01-11-2 ENGINE OIL INSPECTION.)

### Note

- The actual oil level may vary from the specified capacity in some cases.

### Oil capacity

L {US qt, Imp qt}

Item	Engine	
	ZM	FS
Oil replacement*	3.0 {3.2, 2.6}	3.3 {3.5, 2.9}
Oil and oil filter replacement*	3.2 {3.4, 2.8}	3.5 {3.7, 3.1}
Total (dry engine)*	3.4 {3.6, 3.0}	3.7 {3.9, 3.3}

\* : Approximate quantity

### Engine oil grade

**API service SG (Energy Conserving II), SH (Energy Conserving II) or ILSAC (GF-I) SJ or ISLAC (GF-II)**

### Engine oil viscosity

**Above -25 °C {-13 °F}: SAE 10W-30**

**-30 °C—37 °C {-22 °F—98 °F}: SAE 5W-30**

## OIL FILTER REPLACEMENT

1. Remove the oil filter using the **SST**.
2. Use a clean rag to wipe off the mounting surface on the oil filter body.
3. Tighten the filter according to the installation direction on the side of it or packing box using the **SST**.
4. Start the engine and inspect for oil leakage.
5. Inspect the oil level.
  - Add oil if necessary. (See 01-11-2 ENGINE OIL INSPECTION.)

A3U011114300W01

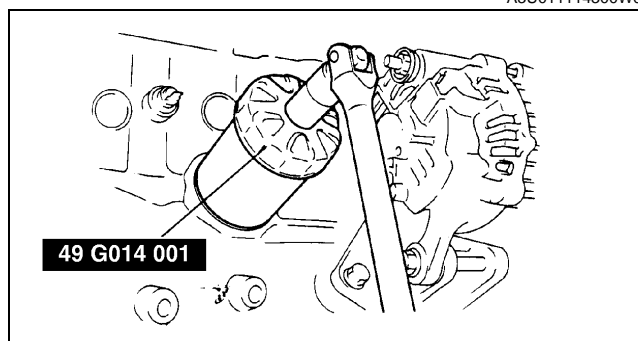

X3U111WA4

# LUBRICATION

A3U011110040W01

## OIL PAN REMOVAL/INSTALLATION

1. Disconnect the negative battery cable.
2. Drain the engine oil. (See 01-11-3 ENGINE OIL REPLACEMENT.)
3. Remove the front pipe.
4. Remove in the order indicated in the table.
5. Install in the reverse order of removal.
6. Start the engine and inspect for engine oil leakage.

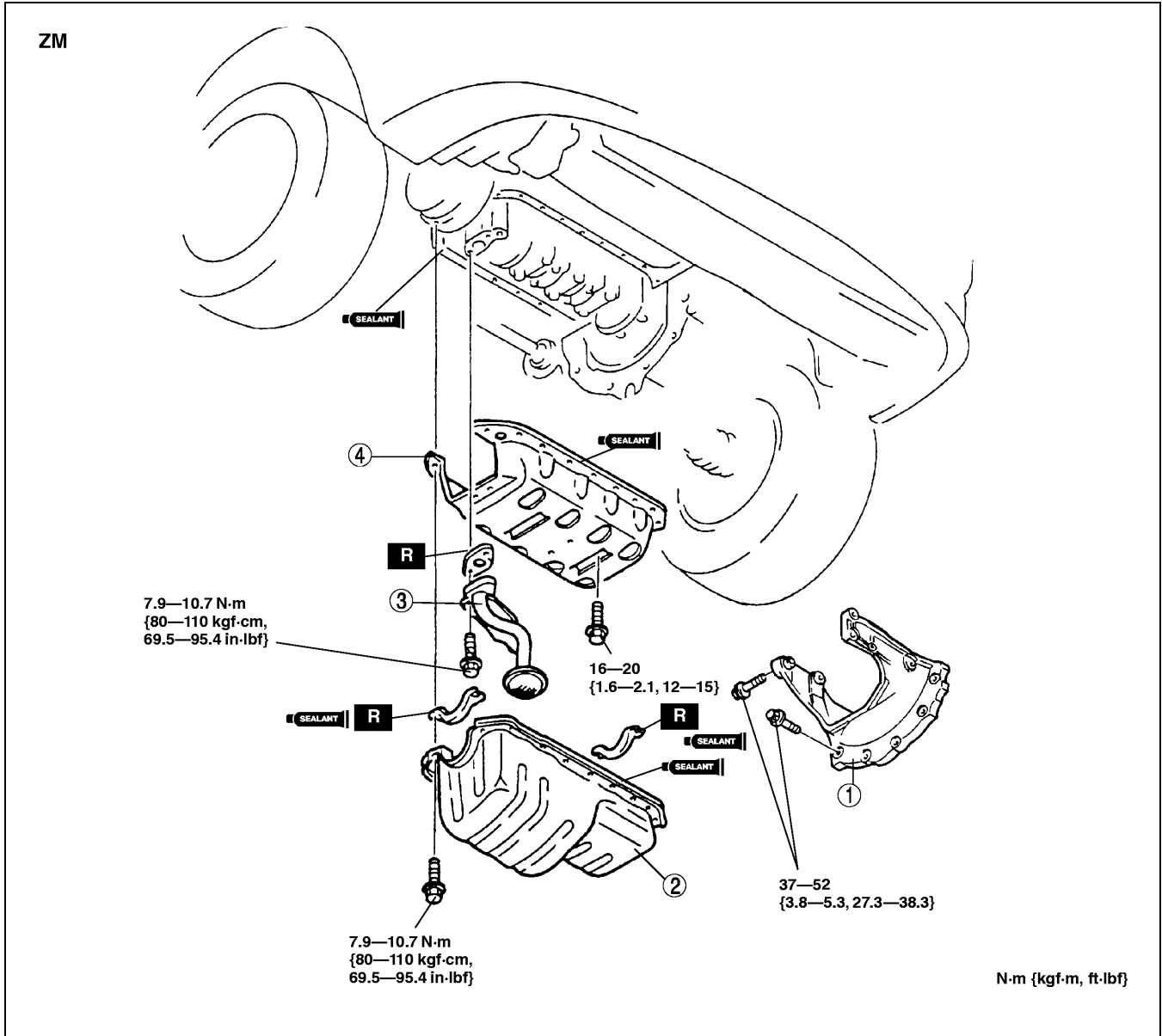

X3U111WA6

1	Integrated stiffener (See 01-11-8 Integrated Stiffener Installation Note)
2	Oil pan (See 01-11-5 Oil Pan Removal Note) (See 01-11-7 Oil Pan Installation Note)

3	Oil strainer
4	MBSP (Main bearing support plate) (See 01-11-6 MBSP (Main bearing support plate) Removal Note) (See 01-11-6 MBSP (Main bearing support plate) Installation Note)



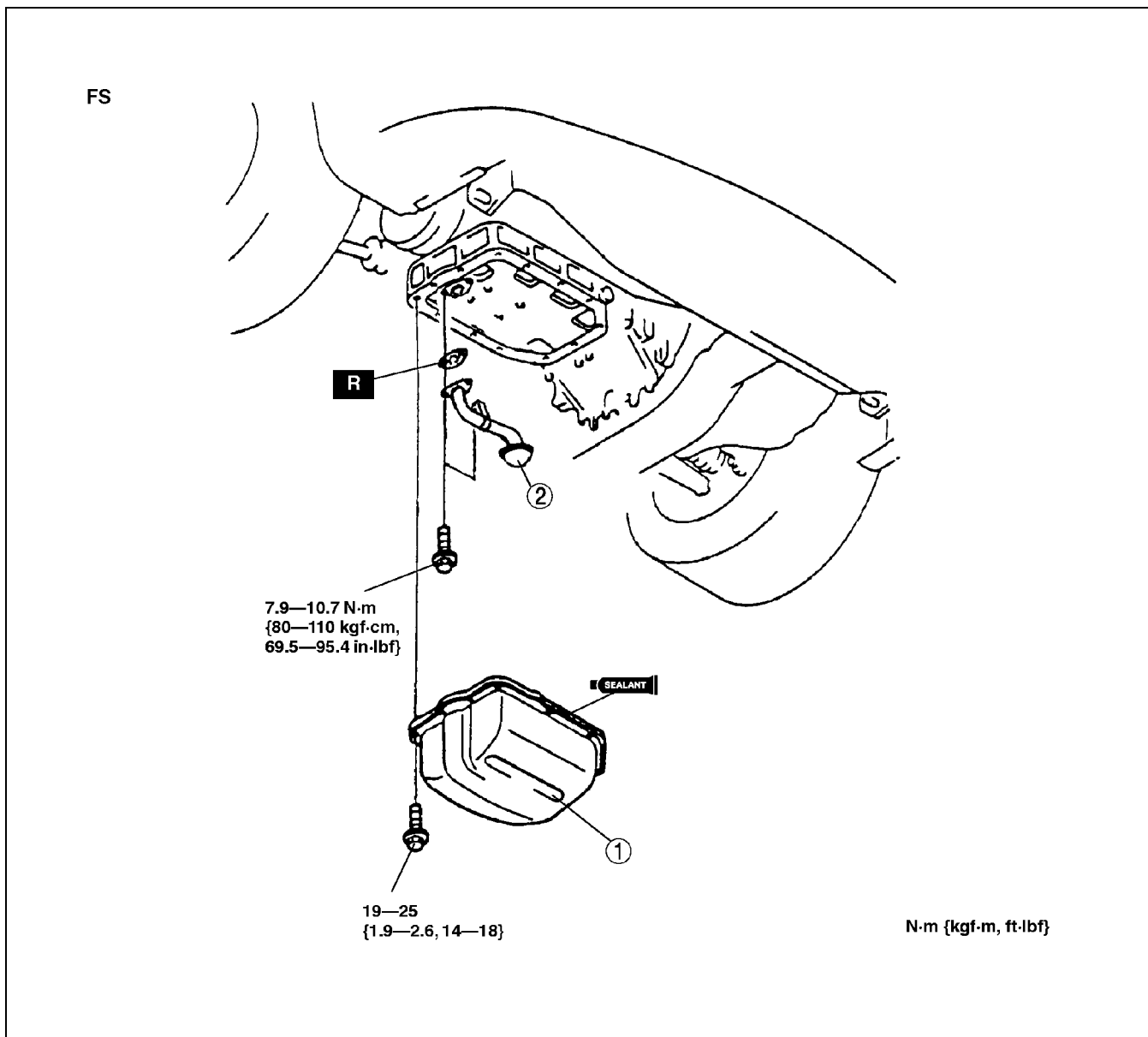

Z3U0111W0999

1	Oil pan (See 01-11-5 Oil Pan Removal Note) (See 01-11-7 Oil Pan Installation Note)
---	--

2	Oil strainer (See 01-11-7 Oil Strainer Installation Note)
---	--

### Oil Pan Removal Note

1. Remove the oil pan mounting bolts.
2. Screw in a oil pan bolt in a weld nut hole to make a small gap between the oil pan upper block and the oil pan. (FS model)

### Caution

- Pry tools can easily scratch the cylinder block and MBSP contact surfaces. Prying off the MBSP can also easily bend the MBSP flange. (ZM model)

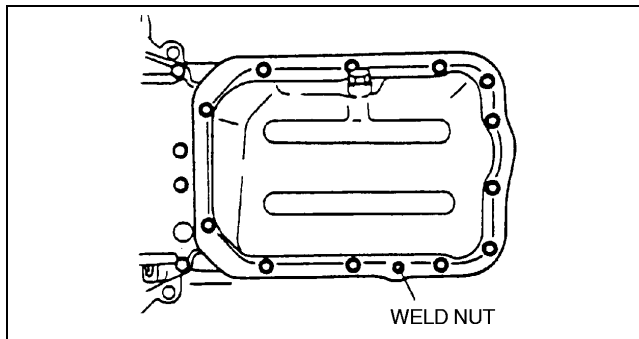

X3U111WA8

# LUBRICATION

3. Remove the oil pan using a separator tool.

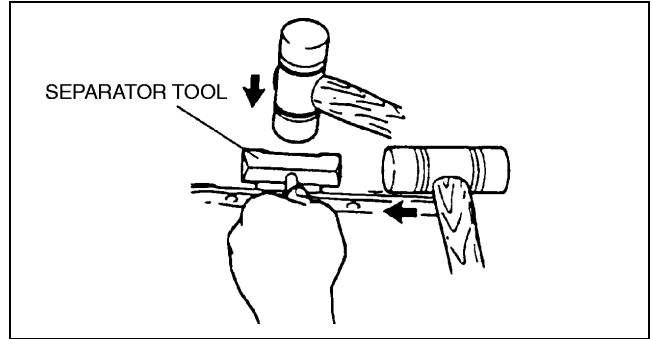

X3U111WAA

## MBSP (Main bearing support plate) Removal Note ZM

1. Using a separator tool, separate the MBSP.

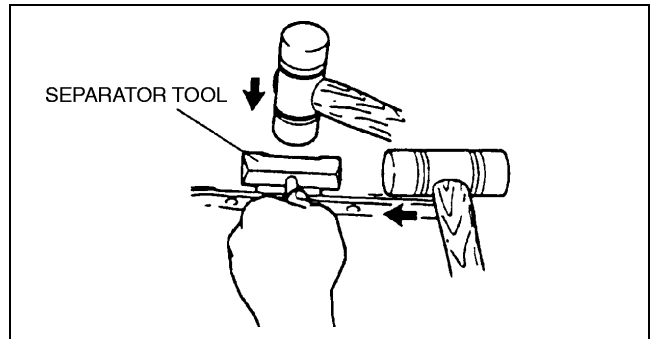

X3U111WAA

## MBSP (Main bearing support plate) Installation Note ZM

1. Apply silicon sealant to the shaded areas as shown.

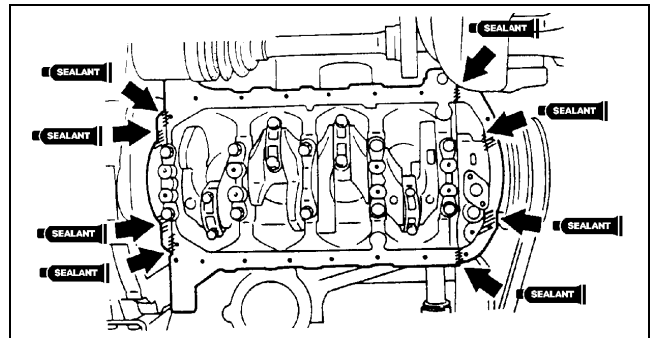

X3U111WAB

2. Apply silicone sealant to the MBSP along the inside of the bolt holes.

### Thickness

2.5—3.5 mm {0.099—0.137 in}

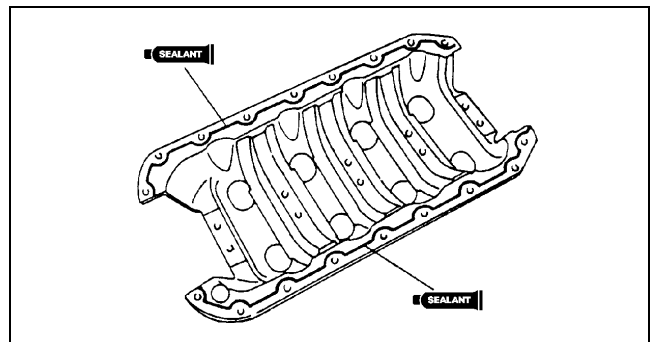

X3U111WAC

# LUBRICATION

## Oil Strainer Installation Note

FS

1. Install the oil strainer gasket as shown.

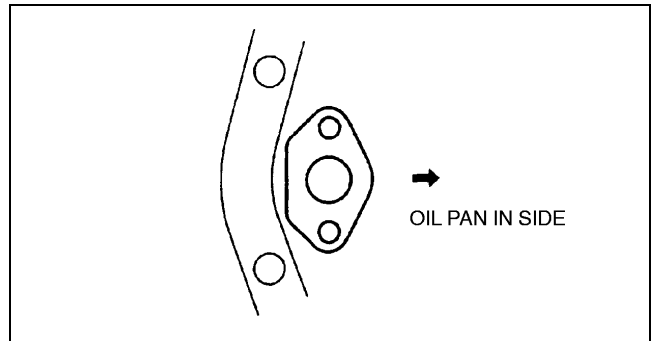

2. Tighten the bolts in the order shown.

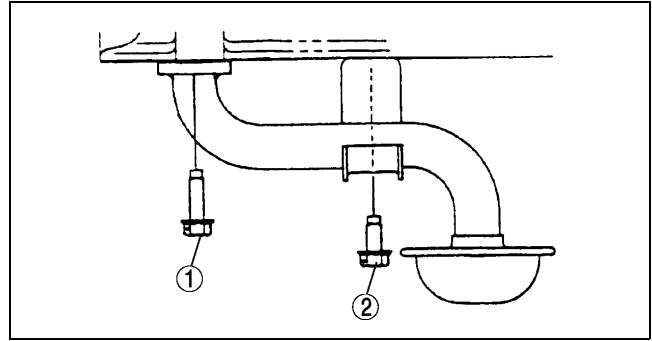

## Oil Pan Installation Note

### Caution

- If the bolts are reused, remove the old sealant from the bolt threads. Tightening a bolt that has old sealant on it can cause bolt hole damage.

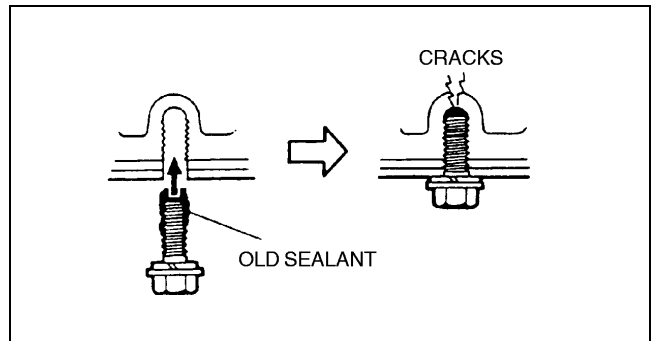

1. Apply silicone sealant to the contact surfaces of new oil pan gaskets as shown. (ZM model)

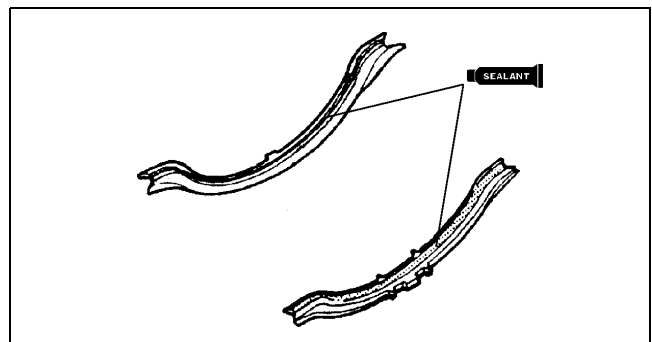

## LUBRICATION

2. Install the new gaskets onto the oil pump body and the rear cover with the projections in the notches as shown. (ZM model)

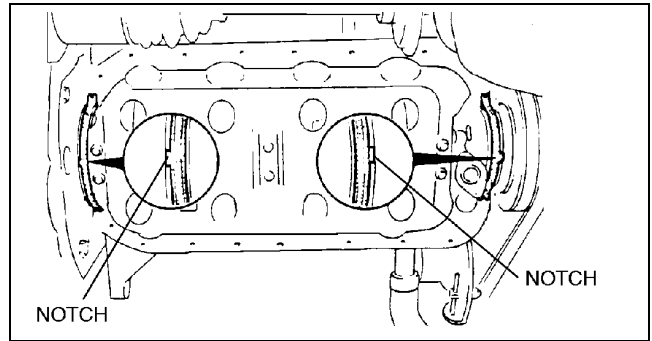

X3U111WAH

3. Apply silicone sealant onto the area of oil pan gasket indicated by A and B. (ZM model)

### Thickness

2.0 mm {0.079 in}

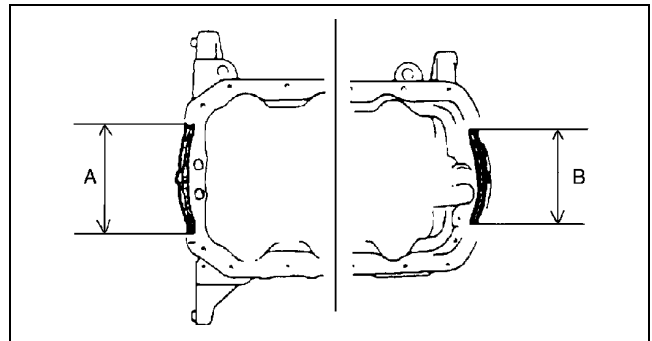

X3U111WAJ

4. Apply silicone sealant to the oil pan along the inside of the bolt holes and overlap the ends.

### Thickness

ZM: 2.5—3.5 mm {0.099—0.137 in}

FS: 2.0—3.0 mm {0.079—0.118 in}

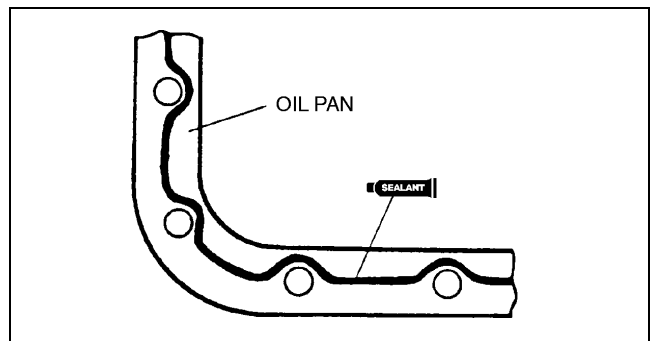

X3U111WAK

### Integrated Stiffener Installation Note

#### ZM

1. Hand-tighten the lock bolt A.

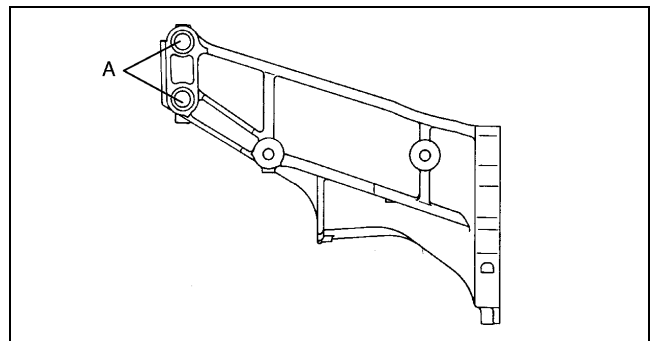

X3U111WAL

# LUBRICATION

2. Hand-tighten the lock bolt B.

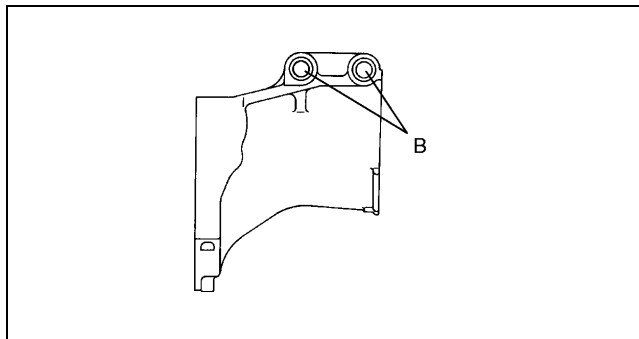

X3U111WAM

3. Tighten the lock bolt C.

**Tightening torque**

**37—52 N·m {3.8—5.3 kgf·m, 27.3—38.3 ft·lbf}**

4. Tighten the lock bolt D.

**Tightening torque**

**37—52 N·m {3.8—5.3 kgf·m, 27.3—38.3 ft·lbf}**

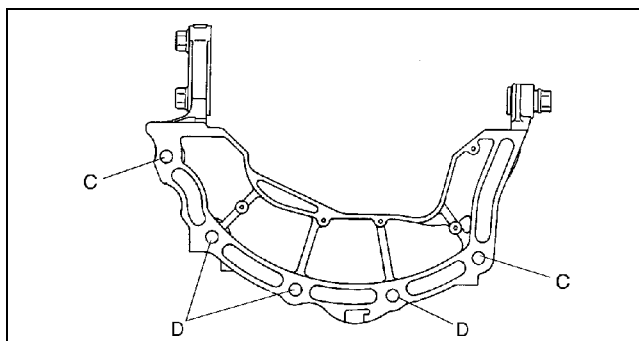

Y3A1111W001

5. Tighten the lock bolt A .

**Tightening torque**

**37—52 N·m {3.8—5.3 kgf·m, 27.3—38.3 ft·lbf}**

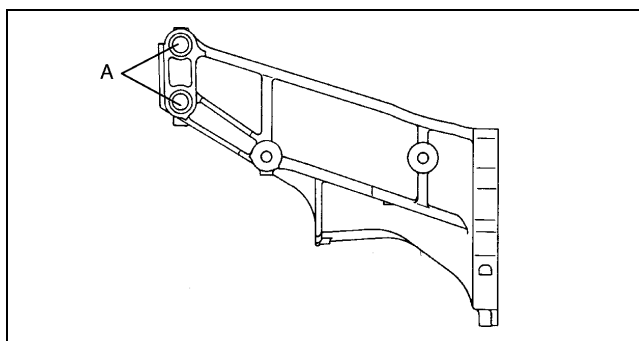

X3U111WAL

6. Tighten the lock bolt B.

**Tightening torque**

**37—52 N·m {3.8—5.3 kgf·m, 27.3—38.3 ft·lbf}**

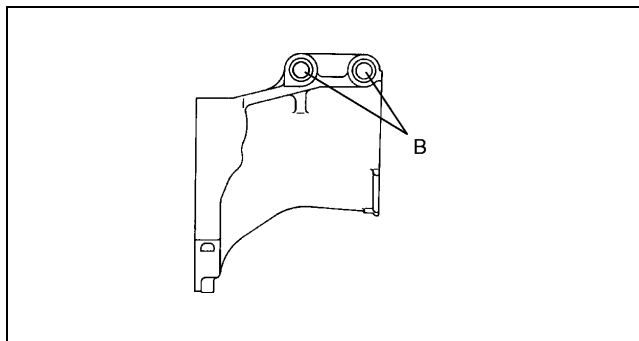

X3U111WAM

# LUBRICATION

## OIL PUMP REMOVAL/INSTALLATION

A3U011119220W01

1. Remove the timing belt. (See 01-10A-9 TIMING BELT REMOVAL/INSTALLATION [ZM].) (See 01-10B-8 TIMING BELT REMOVAL/INSTALLATION [FS].)
2. Remove the timing belt pulley.
3. Remove the oil pan. (See 01-11-4 OIL PAN REMOVAL/INSTALLATION.)
4. Remove the A/C compressor with the pipe still connected.
5. Remove the A/C compressor bracket.
6. Remove the generator. (ZM)
7. Remove the transaxle (FS) (See 05-15B-4 MANUAL TRANSAXLE (MTX) REMOVAL/INSTALLATION [G15M-R].) (See 05-17-31 AUTOMATIC TRANSAXLE (ATX) REMOVAL/INSTALLATION.)
8. Remove in the order indicated in the table.
9. Install in the reverse order of removal.

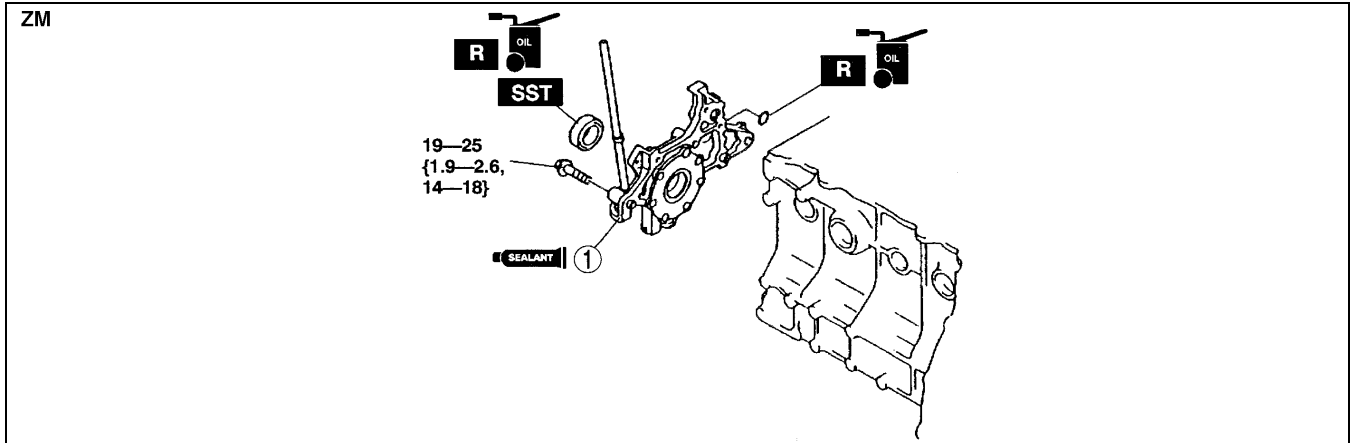

Y3U111WA1

1	Oil pump (See 01-11-12 Oil Pump Removal Note) (See 01-11-12 Oil Pump Installation Note)
---	---

# LUBRICATION

FS

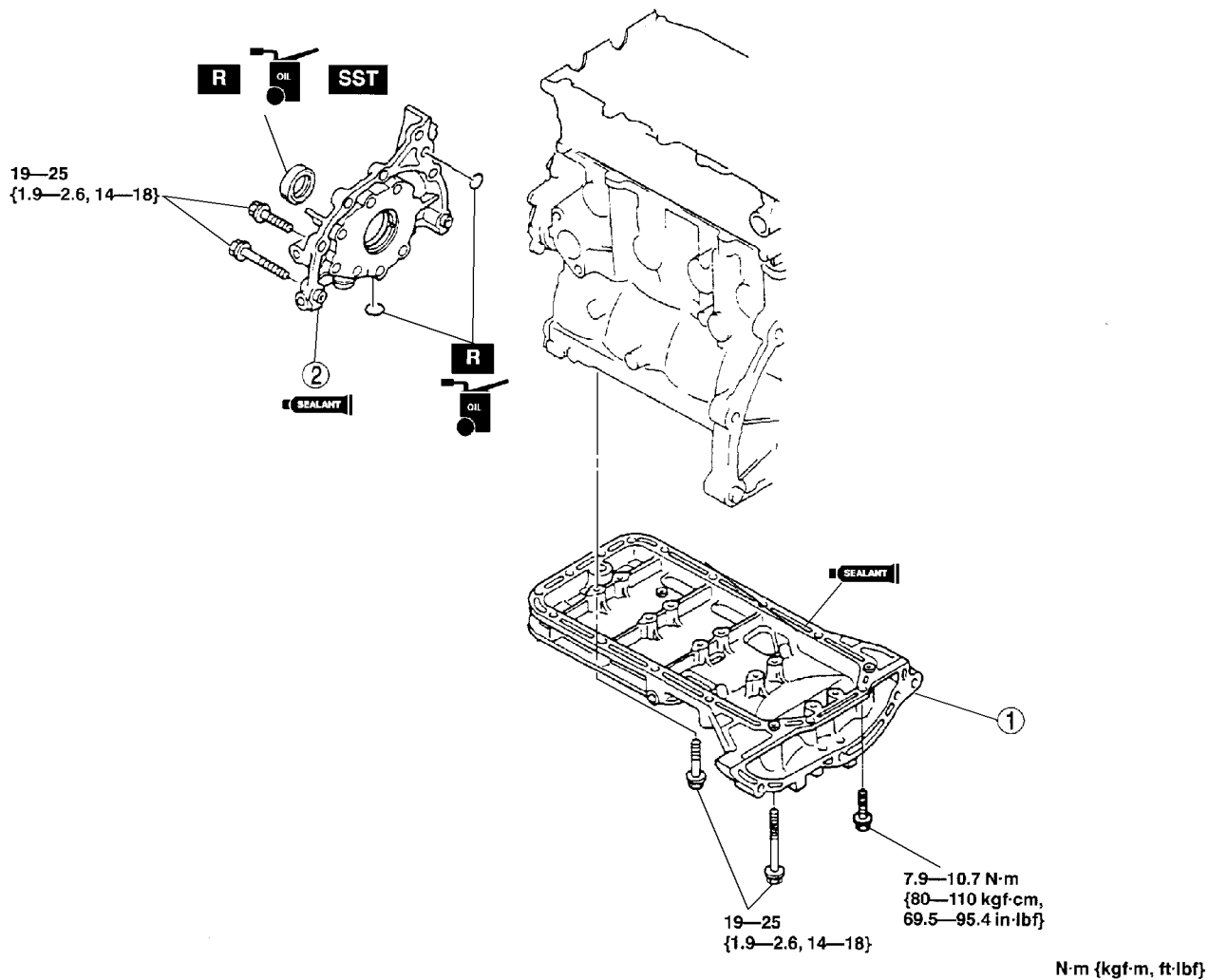

01-11

Z3U0111W998

1	Oil pan upper block (See 01-11-11 Oil Pan Upper Block Removal Note) (See 01-11-13 Oil Pan Upper Block Installation Note)
---	--

2	Oil pump (See 01-11-12 Oil Pump Removal Note) (See 01-11-12 Oil Pump Installation Note)
---	---

### Oil Pan Upper Block Removal Note

1. Remove the two bolts at the rear of the cylinder block.
2. Loosen the oil pan upper block bolts in 2 or 3 steps in the order shown.

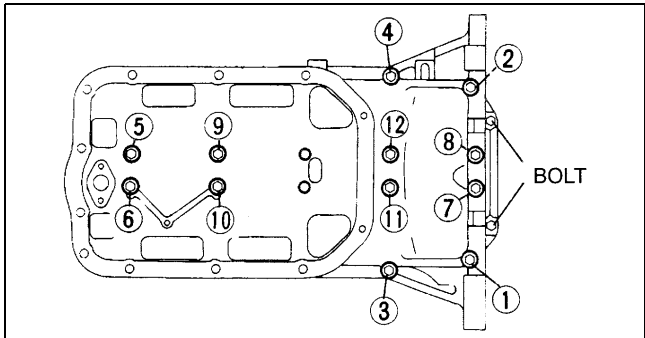

Y3U111WA3

# LUBRICATION

3. Remove the oil pan upper block using the separator tool.

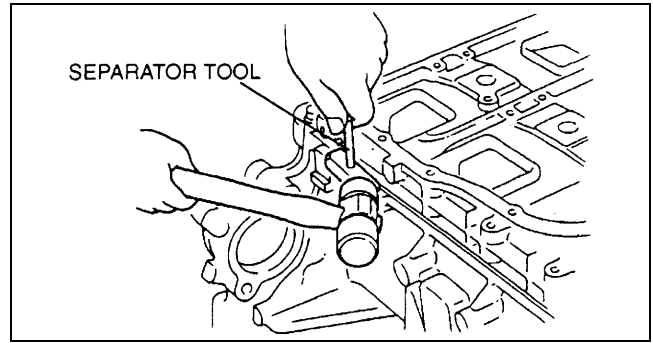

Y3U111WA4

## Oil Pump Removal Note

1. Remove the front oil seal using a screwdriver protected with a rag.

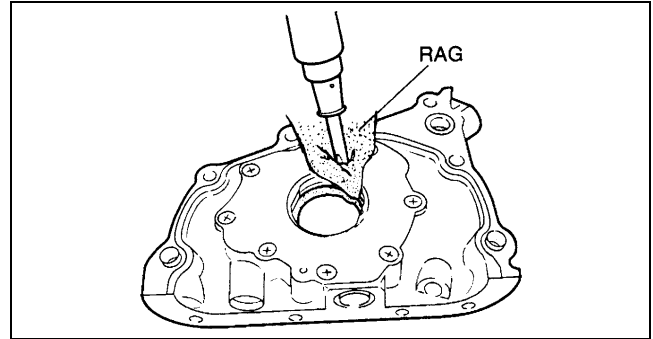

Y3U111WA5

## Oil Pump Installation Note

ZM

1. Apply clean engine oil to the oil seal.
2. Push the oil seal slightly in by hand.
3. Press the oil seal evenly using the **SST**.

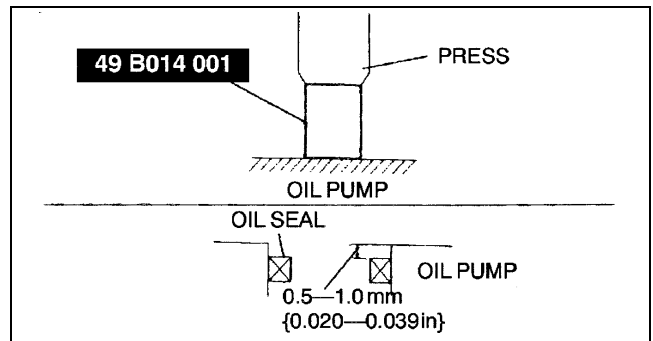

Y3U111WA6

4. Apply silicone sealant to the oil pump as shown.

### Thickness

1.0—2.0 mm {0.040—0.078 in}

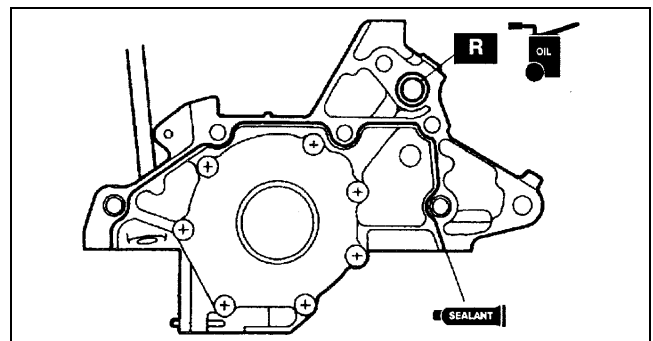

Y3U111WA7



# LUBRICATION

## FS

1. Apply clean engine oil to the oil seal.
2. Push the oil seal slightly in by hand.
3. Press the oil seal evenly using the **SST**.

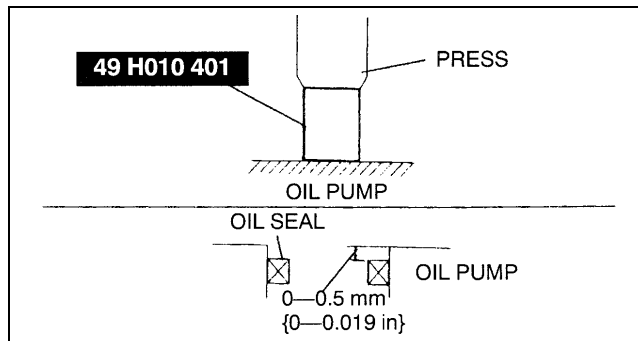

Y3U111WA8

4. Apply silicone sealant to the oil pump as shown.

### Thickness

1.0—2.0 mm {0.040—0.078 in}

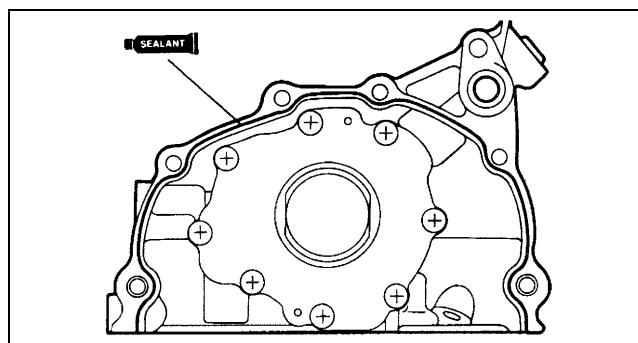

Y3U111WA9

### Oil Pan Upper Block Installation Note

1. Apply silicone sealant to the oil pan upper block as shown.

### Thickness

2.0—3.0 mm {0.08—0.11 in}

2. Tighten the bolts A.

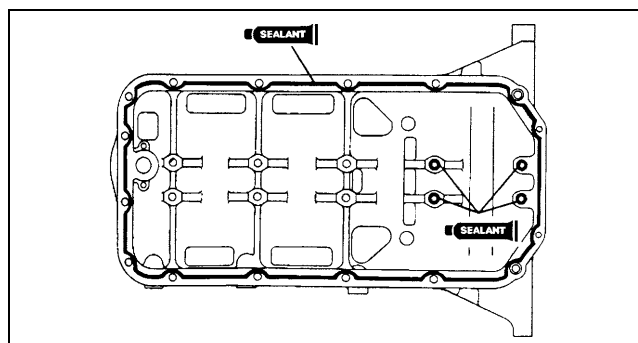

Y3U111WAA

3. Tighten the oil pan upper block bolts in 2 or 3 steps in the order shown.

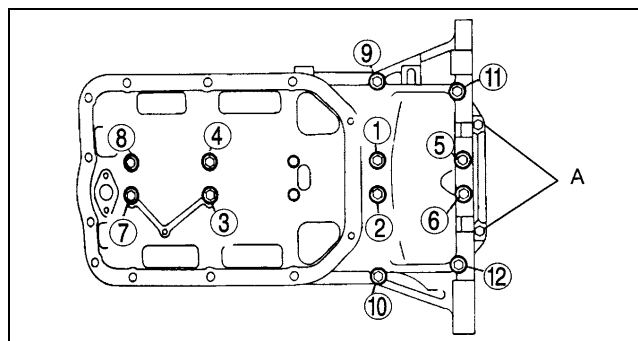

Y3U111WAB

01-11

# LUBRICATION

## OIL PUMP DISASSEMBLY/ASSEMBLY

A3U01119220W02

1. Remove the oil pump. (See 01-11-10 OIL PUMP REMOVAL/INSTALLATION.)
2. Disassemble in the order indicated in the table.
3. Assemble in the reverse order of disassembly.

1	Oil pump cover
2	Inner rotor, Outer rotor (See 01-11-15 Inner Rotor, Outer Rotor Assembly Note)
3	Cotter pin (See 01-11-14 Cotter Pin Assembly Note)
4	Plunger
5	Oil pump body

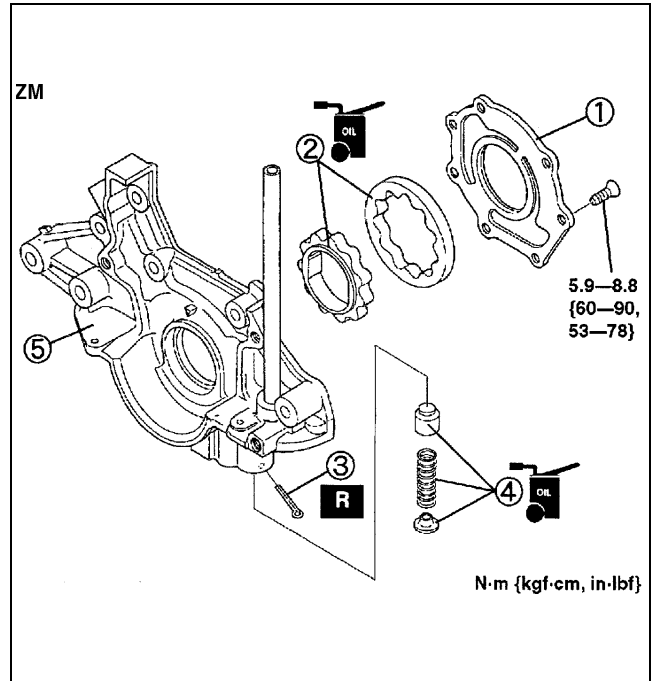

Y3U111WAC

1	Oil pump cover
2	Outer rotor
3	Inner rotor
4	Pressure spring
5	Control plunger
6	Oil pump body

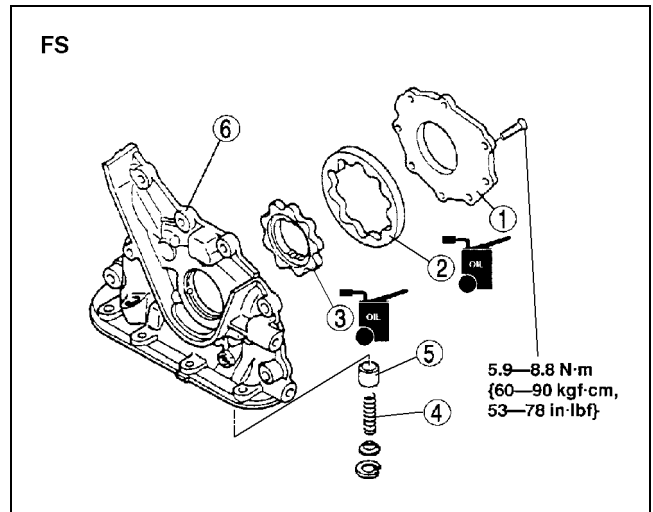

Z3U0111W997

### Cotter Pin Assembly Note

1. Bend the cotter pin so that its tip does not project from the oil pump cover mounting surface.

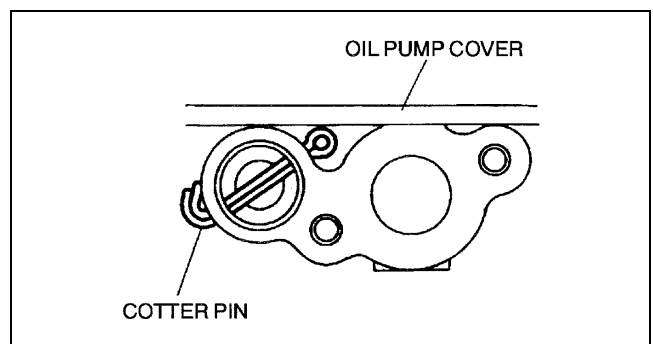

Y3U111WAE

## Inner Rotor, Outer Rotor Assembly Note

- Match the punch marks on the inner and outer rotor before installing the inner and outer rotor.

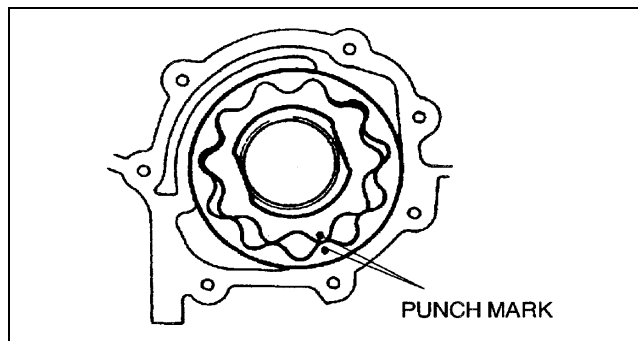

Y3U111WAF

A3U011119220W03

01-11

## OIL PUMP INSPECTION

### Rotor Clearance Inspection

- Measure the following clearance.
  - Replace the rotor and/or pump body if necessary.

ZM

Standard tip clearance  
0.02—0.18 mm {0.0008—0.0070 in}  
Maximum tip clearance  
0.22 mm {0.0087 in}

FS

Standard tip clearance  
0.130—0.206 mm {0.00512—0.00811 in}  
Maximum tip clearance  
0.30 mm {0.012 in}

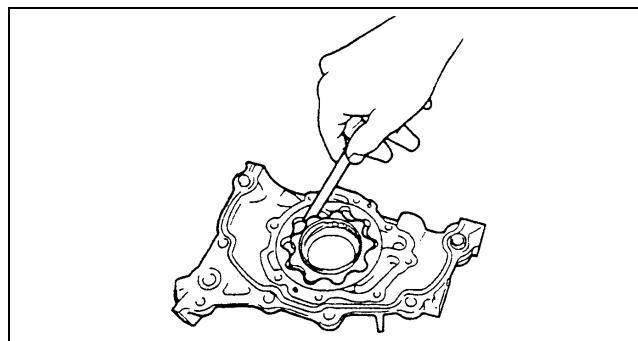

Y3U111WAG

ZM

Standard tip clearance  
0.09—0.18 mm {0.0036—0.0070 in}  
Maximum tip clearance  
0.22 mm {0.0087 in}

FS

Standard tip clearance  
0.113—0.186 mm {0.00445—0.00732 in}  
Maximum tip clearance  
0.22 mm {0.0087 in}

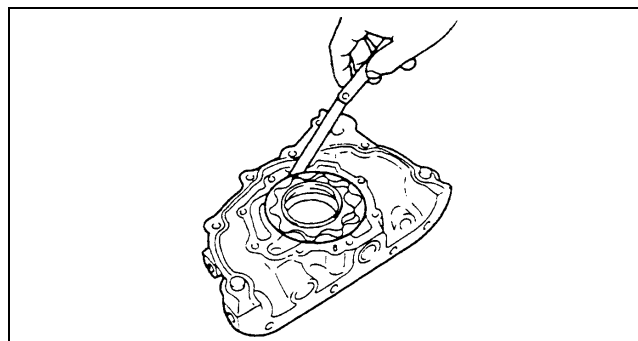

Y3U111WAH

ZM

Standard tip clearance  
0.03—0.11 mm {0.0012—0.0043 in}  
Maximum tip clearance  
0.14 mm {0.0055 in}

FS

Standard tip clearance  
0.035—0.095 mm {0.0014—0.0037 in}  
Maximum tip clearance  
0.14 mm {0.0055 in}

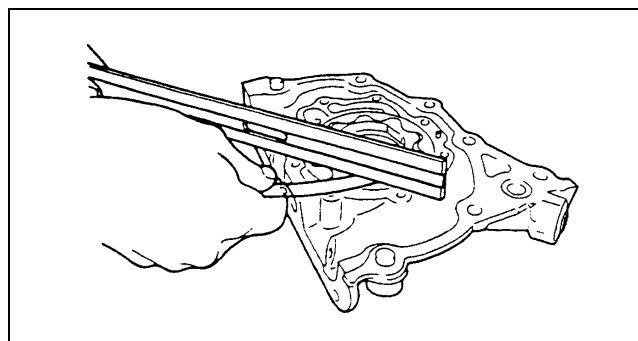

Y3U111WAJ

# LUBRICATION

## Pressure Spring Inspection

### ZM

1. Measure the free length of the pressure spring.
  - Replace the pressure spring if necessary.

#### Free length

45.94 mm {1.809 in}

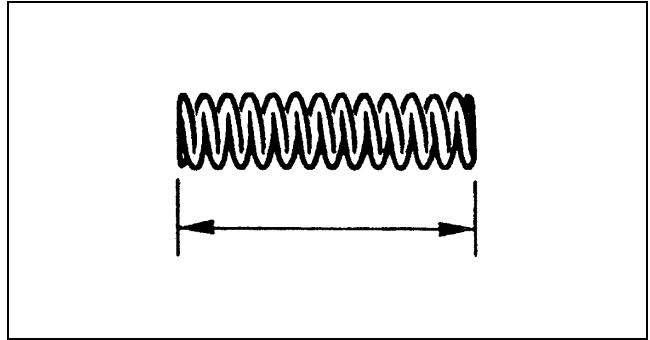

Y3U111WAK

### FS

1. Apply pressing force to the pressure spring and check the spring height.
  - Replace the plunger spring if necessary.

#### Pressing force

97.7—107.4 N {9.96—10.96 kgf, 21.92—24.11 lbf}

#### Standard height

33.50 mm {1.319 in}

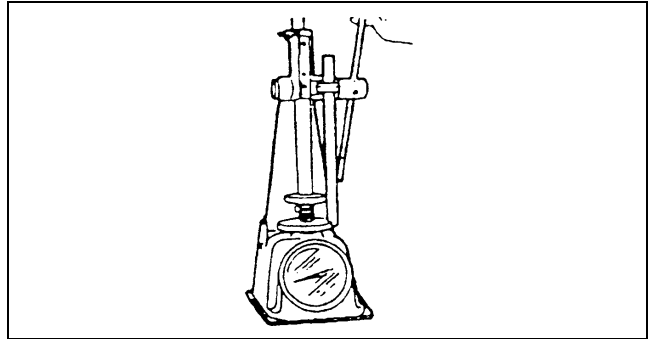

Y3U111WAL

# 01-12 COOLING SYSTEM

**COOLING SYSTEM LOCATION INDEX. 01-12-1**  
**COOLING SYSTEM SERVICE**  
 WARNINGS..... 01-12-2  
**ENGINE COOLANT LEVEL**  
 INSPECTION..... 01-12-2  
**ENGINE COOLANT PROTECTION**  
 INSPECTION..... 01-12-2  
**ENGINE COOLANT REPLACEMENT .. 01-12-3**  
**ENGINE COOLANT LEAKAGE**  
 INSPECTION..... 01-12-4  
**RADIATOR CAP INSPECTION..... 01-12-4**  
**RADIATOR REMOVAL/INSTALLATION 01-12-4**

**THERMOSTAT REMOVAL/**  
**INSTALLATION .....01-12-5**  
 Thermostat Installation Note.....01-12-6  
 Thermostat Cover Gasket Installation  
 Note.....01-12-7  
**THERMOSTAT INSPECTION .....01-12-7**  
**WATER PUMP REMOVAL/**  
**INSTALLATION .....01-12-8**  
 Water Pump Installation Note.....01-12-9  
**COOLING FAN MOTOR INSPECTION ..01-12-9**  
**COOLING FAN MOTOR REMOVAL/**  
**INSTALLATION .....01-12-9**

01-12

## COOLING SYSTEM LOCATION INDEX

A3U011201004W01

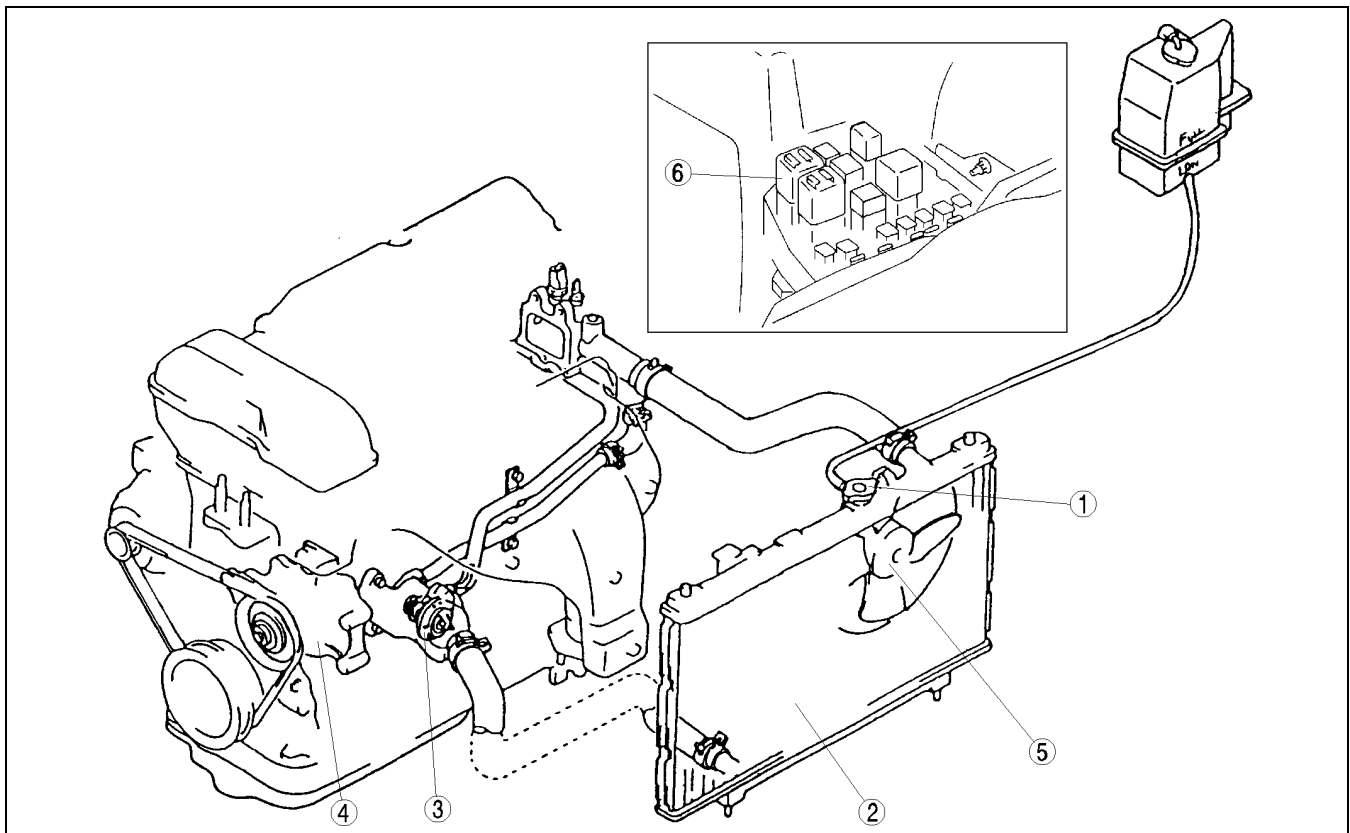

Z3U0112W100

1	Radiator cap (See 01-12-4 RADIATOR CAP INSPECTION)
2	Radiator (See 01-12-4 RADIATOR REMOVAL/ INSTALLATION)
3	Thermostat (See 01-12-5 THERMOSTAT REMOVAL/ INSTALLATION) (See 01-12-7 THERMOSTAT INSPECTION)

4	Water pump (See 01-12-8 WATER PUMP REMOVAL/ INSTALLATION)
5	Cooling fan motor (See 01-12-9 COOLING FAN MOTOR INSPECTION) (See 01-12-9 COOLING FAN MOTOR REMOVAL/ INSTALLATION)
6	Cooling fan relay (See 09-21-5 RELAY INSPECTION)

# COOLING SYSTEM

## COOLING SYSTEM SERVICE WARNINGS

A3U011201004W02

### Warning

- Never remove the radiator cap or the coolant filler cap. Do not loosen the radiator drain plug while the engine is running, or when the engine and radiator are hot. Scalding coolant and steam may shoot out and cause serious injury. It may also damage the engine and cooling system.
- Turn off the engine and wait until it is cool. Even then, be very careful when removing the cap. Wrap a thick cloth around it and slowly turn it counterclockwise to the first stop. Step back while the pressure escapes.
- When you are sure all the pressure is gone, press down on the cap while still using the cloth, turn it, and remove it.
- Hot engines and engine coolant can cause severe burns. Turn off the engine and wait until it and the coolant are cool before draining the engine coolant.

## ENGINE COOLANT LEVEL INSPECTION

A3U011215001W01

1. Remove the radiator cap.
2. Verify that the coolant level is near the radiator filler neck.
3. Verify that the coolant level in the coolant reservoir is between the FULL and LOW marks.
  - Add coolant if necessary.

## ENGINE COOLANT PROTECTION INSPECTION

A3U011215001W02

1. Measure the coolant temperature and specific gravity with a thermometer and a hydrometer.

### Caution

- The engine has aluminum parts that can be damaged by alcohol or methanol antifreeze. Do not use alcohol or methanol in the cooling system. Use only ethylene-glycol-based coolant.
- Use only soft (demineralized) water in the coolant mixture. Water that contains minerals will cut down on the coolant's effectiveness.

2. Determine the coolant protection by referring to the graph shown.
  - If the coolant protection is not correct, add water or coolant.

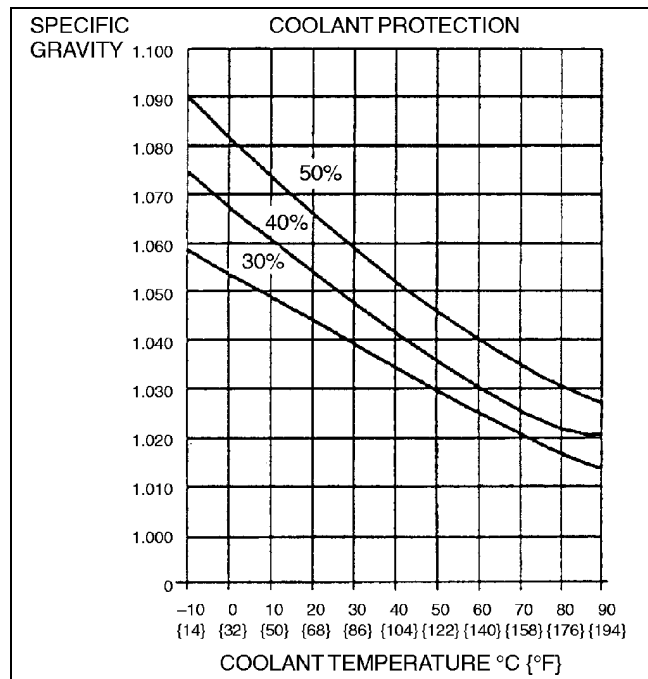

X3U112WA2

# COOLING SYSTEM

## ENGINE COOLANT REPLACEMENT

A3U011215001W03

1. Drain the coolant in the coolant reservoir.
2. Remove the radiator cap and loosen the radiator drain plug.
3. Drain the coolant into a container.
4. Flush the cooling system with water until all traces of color are gone.
5. Let the system drain completely.
6. Tighten the radiator drain plug.

### Caution

- The engine has aluminum parts that can be damaged by alcohol or methanol antifreeze. Do not use alcohol or methanol in the cooling system. Use only ethylene-glycol-based coolant.
- Use only soft (demineralized) water in the coolant mixture. Water that contains minerals will cut down on the coolant's effectiveness.
- Engine coolant will damage paint. Rinse it off quickly.

7. Referring to the following chart, select proper volume percentage of the water and coolant. Slowly pour the coolant into the radiator up to the coolant filler port.

### Filling pace

1.0 L {1.1 US qt, 0.9 Imp qt}/min. [max]

### Antifreeze solution mixture percentage

Coolant protection	Volume percentage		Gravity at 20 °C {68 °F}
	Water	Coolant	
Above -16 °C {4 °F}	65	35	1.054
Above -26 °C {-15 °F}	55	45	1.066
Above -40 °C {-40 °F}	45	55	1.078

8. Pour coolant into the reservoir up to the FULL mark on the coolant reservoir.
9. Fully install the radiator cap.

### Caution

- If the coolant temperature becomes too high, stop the engine to prevent it from overheating.

10. Start the engine and let it idle for **approx. 10 min.**
11. After engine warms up, perform the following steps:
  - (1) Run the engine at **2,500 rpm** for **5 min.**
  - (2) Run the engine at **3,000 rpm** for **5 s**; then return to idling. Repeat this several times.
12. Stop the engine and wait until it is cool.
13. Inspect the coolant level. If it is low, repeat Step 7—12.
14. Verify there is no leakage.

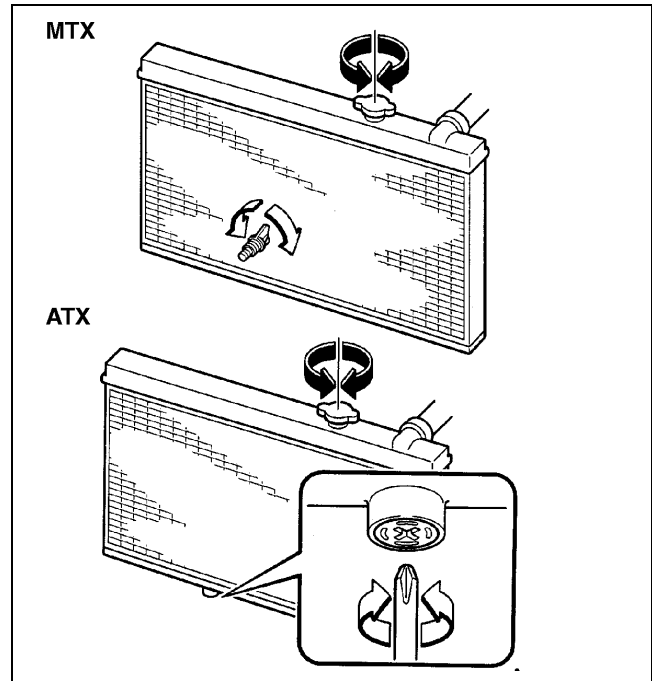

X3U112WA1

# COOLING SYSTEM

## ENGINE COOLANT LEAKAGE INSPECTION

A3U011215001W04

1. Inspect the coolant level.
2. Remove the radiator cap.
3. Connect a radiator cap tester and the **SST** to the radiator filler neck.

### Caution

- Applying more than 123 kPa {1.25 kgf/cm<sup>2</sup>, 17.8 psi} can damage the hoses, fittings, and other components, and cause leaks.

4. Apply pressure to the radiator.

### Pressure

123 kPa {1.25 kgf/cm<sup>2</sup>, 17.8 psi}

5. Verify that the pressure is held.
  - If not, inspect the system for coolant leakage.

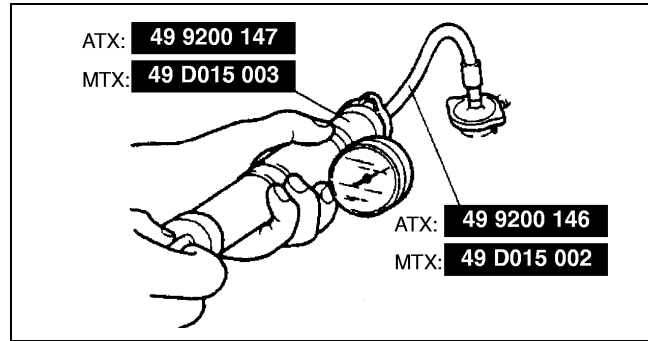

X3U112WA3

## RADIATOR CAP INSPECTION

A3U011215201W01

### Warning

- Never remove the radiator cap while the engine is running, or when the engine and radiator are hot. Scalding coolant and steam may shoot out and cause serious injury. It may also damage the engine and cooling system.
- Turn off the engine and wait until it is cool. Even then, be very careful when removing the cap. Wrap a thick cloth around it and slowly turn it counterclockwise to the first stop. Step back while the pressure escapes.
- When you're sure all the pressure is gone, press down on the cap while still using the cloth, turn it, and remove it.

1. Attach the radiator cap to a radiator cap tester with the **SST**. Apply pressure gradually.
2. Verify that the pressure becomes stable within the specification.
  - If the pressure is held for 10 s, the radiator cap is normal.

### Pressure

94—122 kPa {0.95—1.25 kgf/cm<sup>2</sup>, 13.5—17.7 psi}

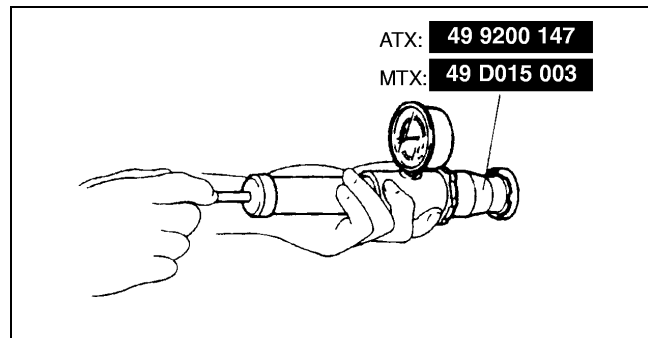

X3U112WA4

## RADIATOR REMOVAL/INSTALLATION

A3U011215200W01

1. Disconnect the negative battery cable.
2. Drain the engine coolant. (See 01-12-2 COOLING SYSTEM SERVICE WARNINGS.) (See 01-12-3 ENGINE COOLANT REPLACEMENT.)
3. Remove the fresh air duct.
4. Remove in the order indicated in the table.
5. Install in the reverse order of removal.



# COOLING SYSTEM

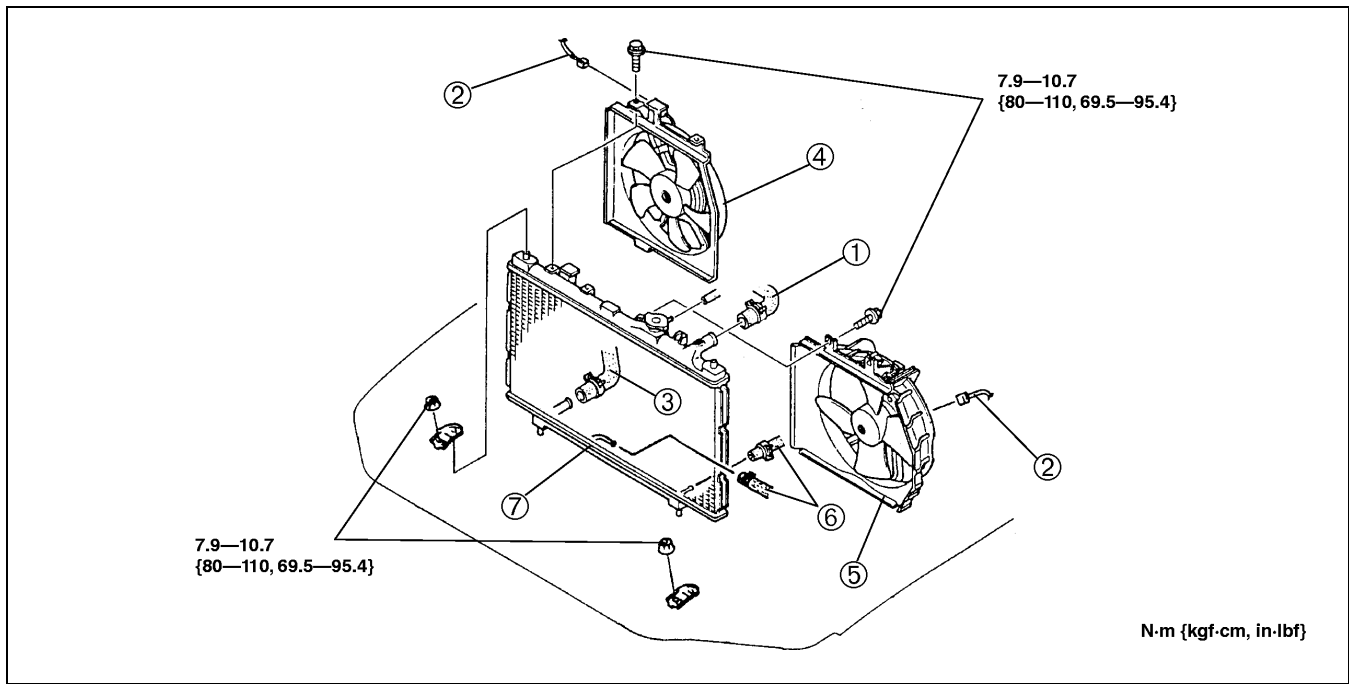

01-12

X3U112WA5

1	Upper radiator hose
2	Cooling fan motor connector, condenser fan motor connector
3	Lower radiator hose
4	Condenser fan

5	Cooling fan
6	Oil hose (ATX) (See 05-17-41 OIL COOLER REMOVAL/INSTALLATION)
7	Radiator

## THERMOSTAT REMOVAL/INSTALLATION

A3U011215171W01

1. Disconnect the negative battery cable.
2. Remove the fresh air duct.
3. Remove the air cleaner. (ZM model)
4. Drain the engine coolant. (See 01-12-2 COOLING SYSTEM SERVICE WARNINGS.) (See 01-12-3 ENGINE COOLANT REPLACEMENT.)
5. Remove in the order indicated in the table.

1	Thermostat cover
2	Thermostat cover gasket (See 01-12-7 Thermostat Cover Gasket Installation Note)
3	Thermostat (See 01-12-6 Thermostat Installation Note)

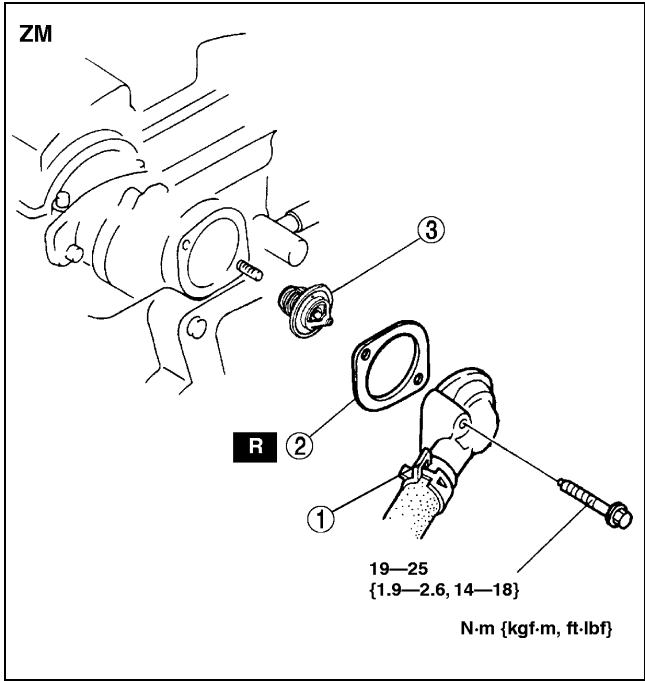

Y3U112WA1

# COOLING SYSTEM

1	Lower radiator hose
2	Thermostat cover
3	Thermostat (See 01-12-6 Thermostat Installation Note)

6. Install in the reverse order of removal.

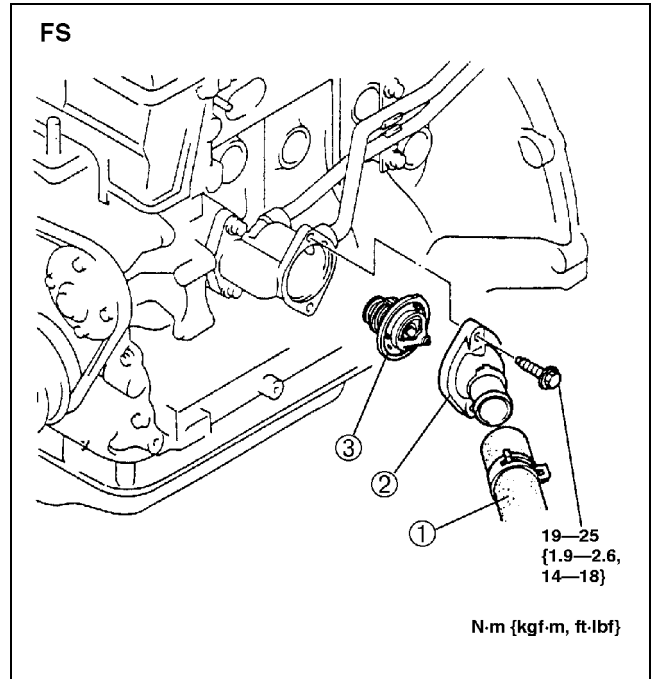

## Thermostat Installation Note

### ZM

1. Install the thermostat into the cylinder head with the jiggle pin at the top.

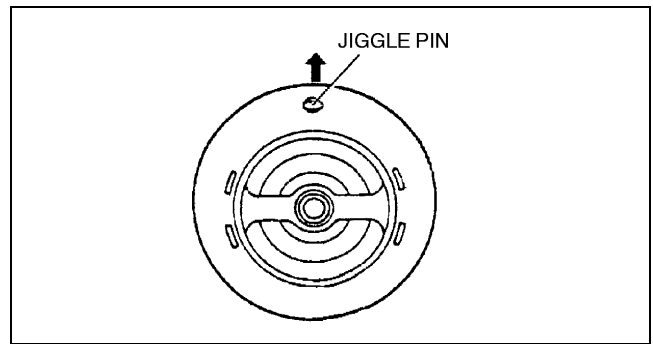

### FS

1. Install the thermostat into the thermostat case with the jiggle pin and projection at the top.
2. Install the thermostat into the thermostat case, aligning the projection on the gasket to the thermostat case.

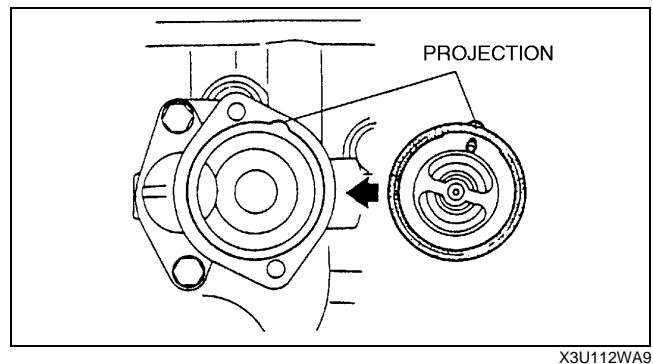

# COOLING SYSTEM

## Thermostat Cover Gasket Installation Note

ZM

1. Install a new gasket with the seal ring side facing the cylinder head.

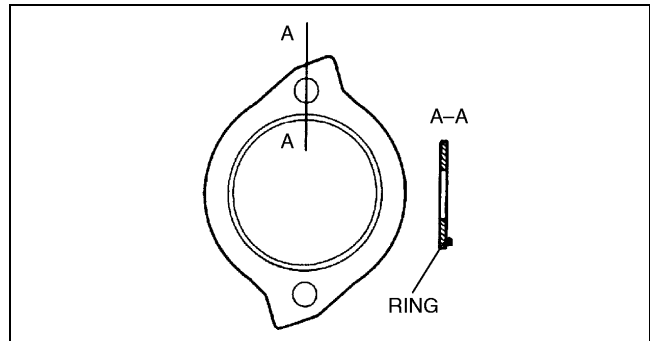

X3U112WAA

01-12

## THERMOSTAT INSPECTION

1. If the gasket of the thermostat is damaged, replace the thermostat assembly. (FS model)
2. Visually check that the thermostat valve is closed.
3. Place the thermostat and a thermometer in water.

### Warning

- During inspection, the thermostat and water are extremely hot and they can cause severe burns. Do not touch the thermostat and water directly.

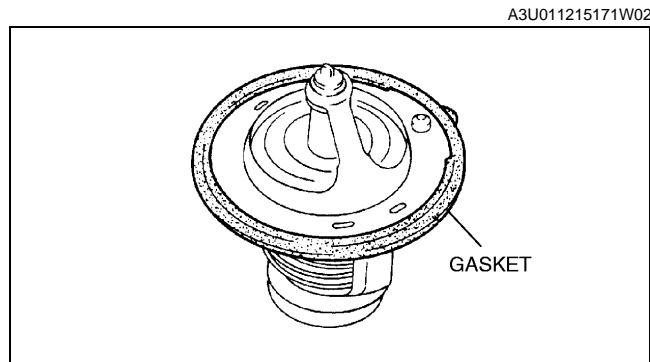

A3U011215171W02

X3U112WAK

4. Heat the water and check the following.
  - If not as specified, replace the thermostat.

Item	Engine	
	ZM	FS
Initial-opening temperature (°C {°F})	83.5—88.0 {183—190}	80—84 {176—183}
Full-open temperature (°C {°F})	100 {212}	95 {203}
Full-open lift (mm {in})	8.5 {0.33} min.	

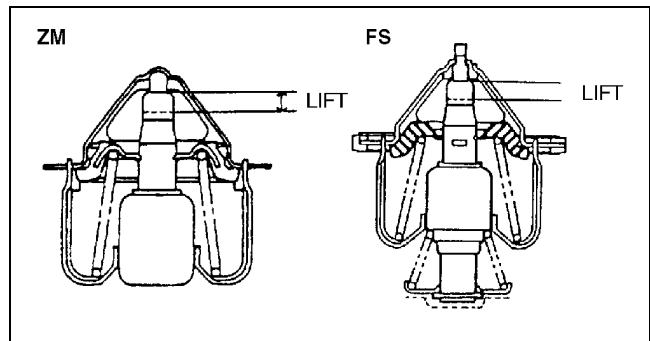

Z3U0112W998

# COOLING SYSTEM

## WATER PUMP REMOVAL/INSTALLATION

A3U011215010W01

1. Drain the engine coolant. (See 01-12-2 COOLING SYSTEM SERVICE WARNINGS.) (See 01-12-3 ENGINE COOLANT REPLACEMENT.)
2. Remove the fresh air duct and air cleaner. (ZM model)
3. Remove the exhaust manifold insulator. (ZM model)
4. Remove the timing belt. (See 01-10A-9 TIMING BELT REMOVAL/INSTALLATION [ZM].) (See 01-10B-8 TIMING BELT REMOVAL/INSTALLATION [FS].)
5. Remove the P/S oil pump with the oil hose still connected. Position the P/S oil pump so that it is out of the way. (ZM model)
6. Remove the A/C compressor and A/C compressor bracket with the pipe still connected. Position the A/C compressor so that it is out of the way. (ZM model)
7. Remove in the order indicated in the table.

1	Water inlet pipe
2	Water pump (See 01-12-9 Water Pump Installation Note)

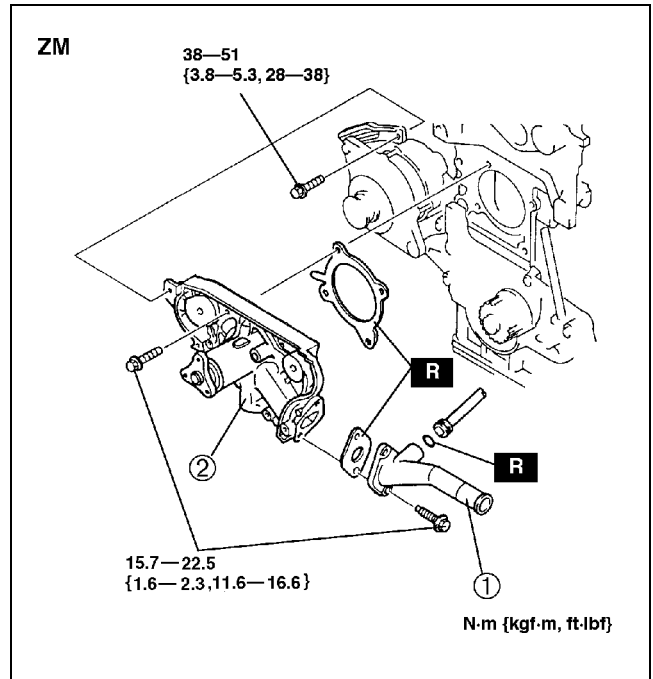

Z3U0112W997

1	P/S oil pump adjuster
2	Water pump

8. Install in the reverse order of removal.

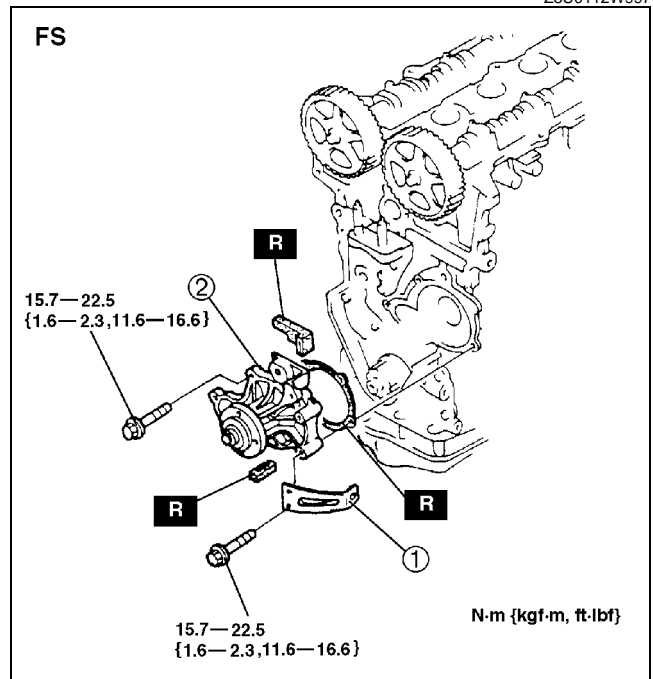

Z3U0112W996

# COOLING SYSTEM

## Water Pump Installation Note

ZM

1. Install a new gasket with the sealing ring facing the water pump.

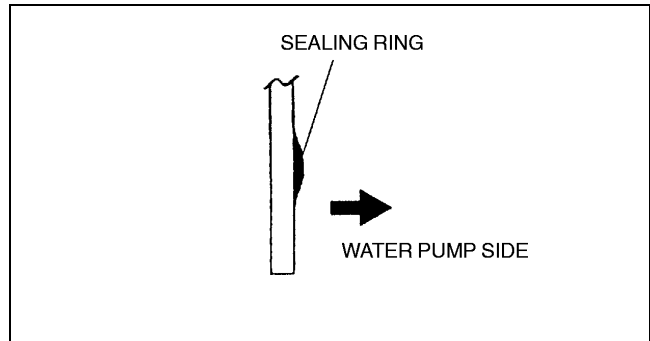

X3U112WAD

01-12

## COOLING FAN MOTOR INSPECTION

1. Verify that the battery is fully charged. (See 01-17-1 Battery.)
2. Connect B+ and an ammeter to the cooling fan motor connector.
3. Verify that the cooling fan motor operates smoothly at the standard current draw.
  - If not as specified, replace the cooling fan motor.

A3U011215025W01

Item		Transaxle	
		MTX	ATX
Current	(A)	2.4—4.4	5.2—7.2

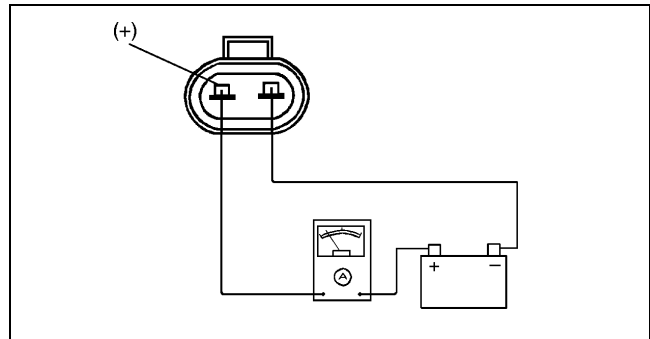

X3U112WAF

## COOLING FAN MOTOR REMOVAL/INSTALLATION

1. Remove the cooling fan. (See 01-12-4 RADIATOR REMOVAL/INSTALLATION.)
2. Remove in the order indicated in the table.

A3U011215025W02

1	Cooling fan blade
2	Cooling fan motor
3	Radiator cowling

3. Install in the reverse order of removal.

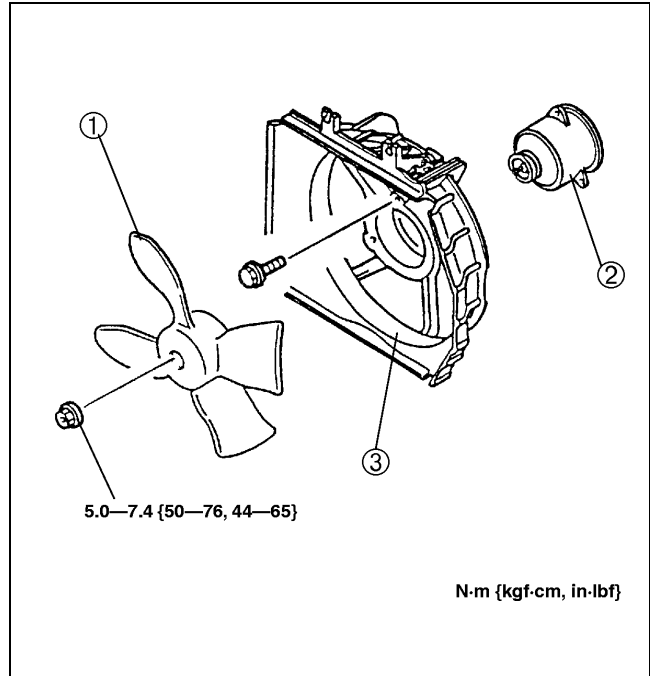

X3U112WAG

**01-13A INTAKE-AIR SYSTEM [ZM]**

<b>INTAKE-AIR SYSTEM LOCATION</b>		<b>(VTCS) CHECK VALVE (ONE-WAY)</b>	
<b>INDEX [ZM]</b> .....	01-13A-2	<b>INSPECTION [ZM]</b> .....	01-13A-9
<b>INTAKE-AIR SYSTEM FLOW</b>		<b>VARIABLE TUMBLE CONTROL SYSTEM</b>	
<b>DIAGRAM [ZM]</b> .....	01-13A-3	<b>(VTCS) SHUTTER VALVE ACTUATOR</b>	
<b>VACUUM HOSE ROUTING DIAGRAM</b>		<b>REMOVAL/INSTALLATION [ZM]</b> .....	01-13A-9
<b>[ZM]</b> .....	01-13A-3	<b>VARIABLE TUMBLE CONTROL SYSTEM</b>	
<b>INTAKE-AIR SYSTEM</b>		<b>(VTCS) SHUTTER VALVE ACTUATOR</b>	
<b>REMOVAL/INSTALLATION [ZM]</b> .....	01-13A-5	<b>INSPECTION [ZM]</b> .....	01-13A-10
Throttle Body Removal Note .....	01-13A-6	Operating Inspection .....	01-13A-10
Intake Manifold Removal Note .....	01-13A-6	<b>VARIABLE TUMBLE CONTROL SYSTEM</b>	
Intake Manifold Gasket Installation		<b>(VTCS) DELAY VALVE</b>	
Note .....	01-13A-6	<b>REMOVAL/INSTALLATION [ZM]</b> .....	01-13A-10
Throttle Body Installation Note .....	01-13A-6	<b>VARIABLE TUMBLE CONTROL SYSTEM</b>	
Accelerator Cable Installation Note ...	01-13A-6	<b>(VTCS) DELAY VALVE</b>	
<b>IDLE AIR CONTROL (IAC) VALVE</b>		<b>INSPECTION [ZM]</b> .....	01-13A-11
<b>REMOVAL/INSTALLATION [ZM]</b> .....	01-13A-6	<b>VARIABLE TUMBLE CONTROL SYSTEM</b>	
<b>IDLE AIR CONTROL (IAC) VALVE</b>		<b>(VTCS) SOLENOID VALVE</b>	
<b>INSPECTION [ZM]</b> .....	01-13A-7	<b>INSPECTION [ZM]</b> .....	01-13A-11
Resistance Inspection .....	01-13A-7	Simulation Test .....	01-13A-11
Circuit Open/Short Inspection .....	01-13A-7	Airflow Inspection .....	01-13A-11
<b>VARIABLE TUMBLE CONTROL SYSTEM</b>		Circuit Open/Short Inspection .....	01-13A-12
<b>(VTCS) DIAGRAM [ZM]</b> .....	01-13A-8	<b>ACCELERATOR CABLE</b>	
<b>VARIABLE TUMBLE CONTROL SYSTEM</b>		<b>REMOVAL/INSTALLATION [ZM]</b> .....	01-13A-12
<b>(VTCS) CHECK VALVE (ONE-WAY)</b>		Accelerator Pedal Installation Note ...	01-13A-13
<b>REMOVAL/INSTALLATION [ZM]</b> .....	01-13A-8	<b>ACCELERATOR CABLE</b>	
<b>VARIABLE TUMBLE CONTROL SYSTEM</b>		<b>INSPECTION/ADJUSTMENT [ZM]</b> .....	01-13A-13

---

**01-13A**

# INTAKE-AIR SYSTEM [ZM]

## INTAKE-AIR SYSTEM LOCATION INDEX [ZM]

A3U011301005W03

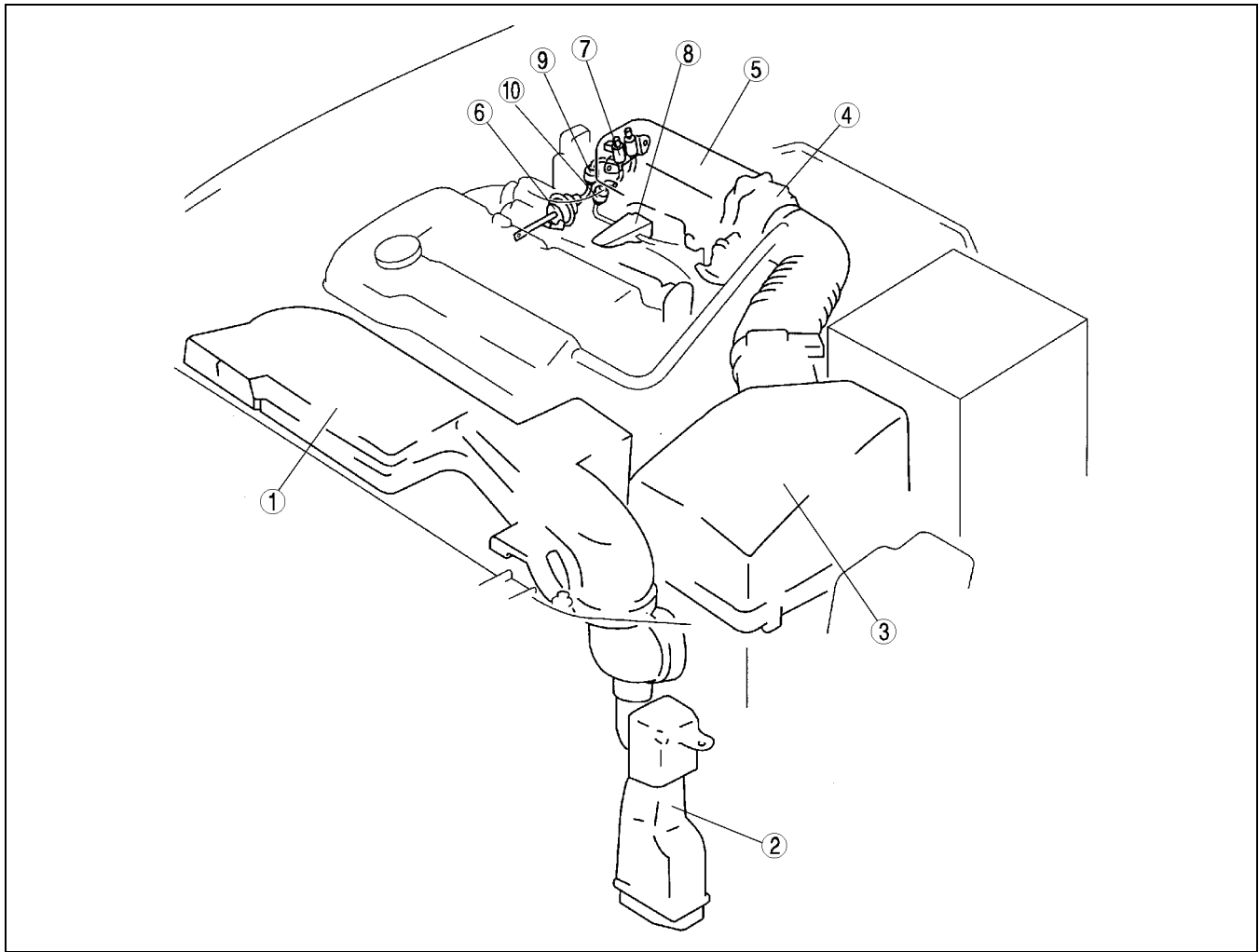

Z3U0113W001

1	Fresh-air duct (See 01-13A-5 INTAKE-AIR SYSTEM REMOVAL/INSTALLATION [ZM])
2	Resonance chamber (See 01-13A-5 INTAKE-AIR SYSTEM REMOVAL/INSTALLATION [ZM])
3	Air cleaner (See 01-13A-5 INTAKE-AIR SYSTEM REMOVAL/INSTALLATION [ZM])
4	Throttle body (See 01-13A-5 INTAKE-AIR SYSTEM REMOVAL/INSTALLATION [ZM])
5	Intake manifold (See 01-13A-5 INTAKE-AIR SYSTEM REMOVAL/INSTALLATION [ZM])
6	VTCS shutter valve actuator (See 01-13A-9 VARIABLE TUMBLE CONTROL SYSTEM (VTCS) SHUTTER VALVE ACTUATOR REMOVAL/INSTALLATION [ZM]) (See 01-13A-10 VARIABLE TUMBLE CONTROL SYSTEM (VTCS) SHUTTER VALVE ACTUATOR INSPECTION [ZM])

7	VTCS solenoid valve (See 01-13A-5 INTAKE-AIR SYSTEM REMOVAL/INSTALLATION [ZM]) (See 01-13A-11 VARIABLE TUMBLE CONTROL SYSTEM (VTCS) SOLENOID VALVE INSPECTION [ZM])
8	VTCS vacuum chamber
9	VTCS delay valve (See 01-13A-10 VARIABLE TUMBLE CONTROL SYSTEM (VTCS) DELAY VALVE REMOVAL/INSTALLATION [ZM]) (See 01-13A-11 VARIABLE TUMBLE CONTROL SYSTEM (VTCS) DELAY VALVE INSPECTION [ZM])
10	VTCS check valve (one-way) (See 01-13A-8 VARIABLE TUMBLE CONTROL SYSTEM (VTCS) CHECK VALVE (ONE-WAY) REMOVAL/INSTALLATION [ZM]) (See 01-13A-8 VARIABLE TUMBLE CONTROL SYSTEM (VTCS) CHECK VALVE (ONE-WAY) REMOVAL/INSTALLATION [ZM])

# INTAKE-AIR SYSTEM [ZM]

## INTAKE-AIR SYSTEM FLOW DIAGRAM [ZM]

A3U011301005W04

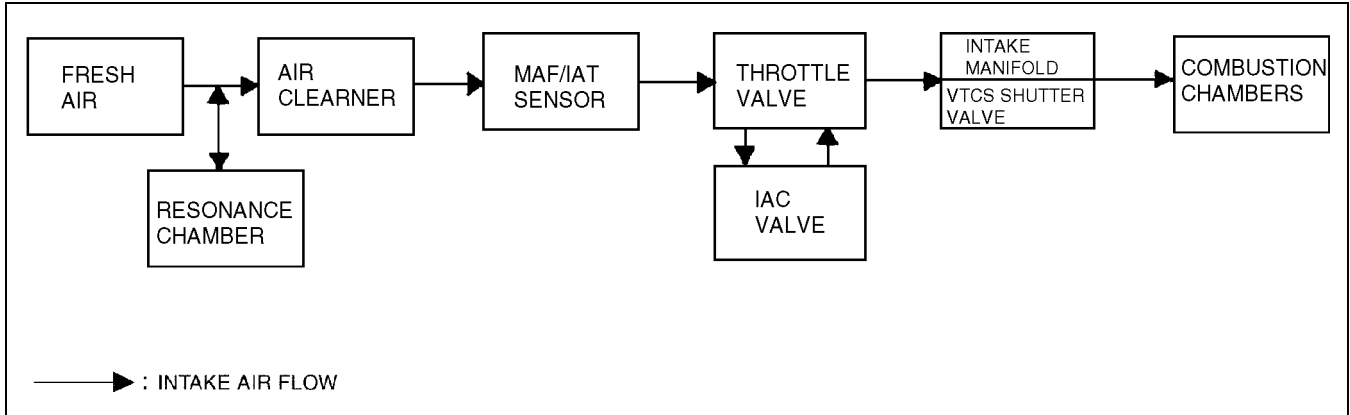

Z3U0113W002

01-13A

## VACUUM HOSE ROUTING DIAGRAM [ZM]

A3U011320030W02

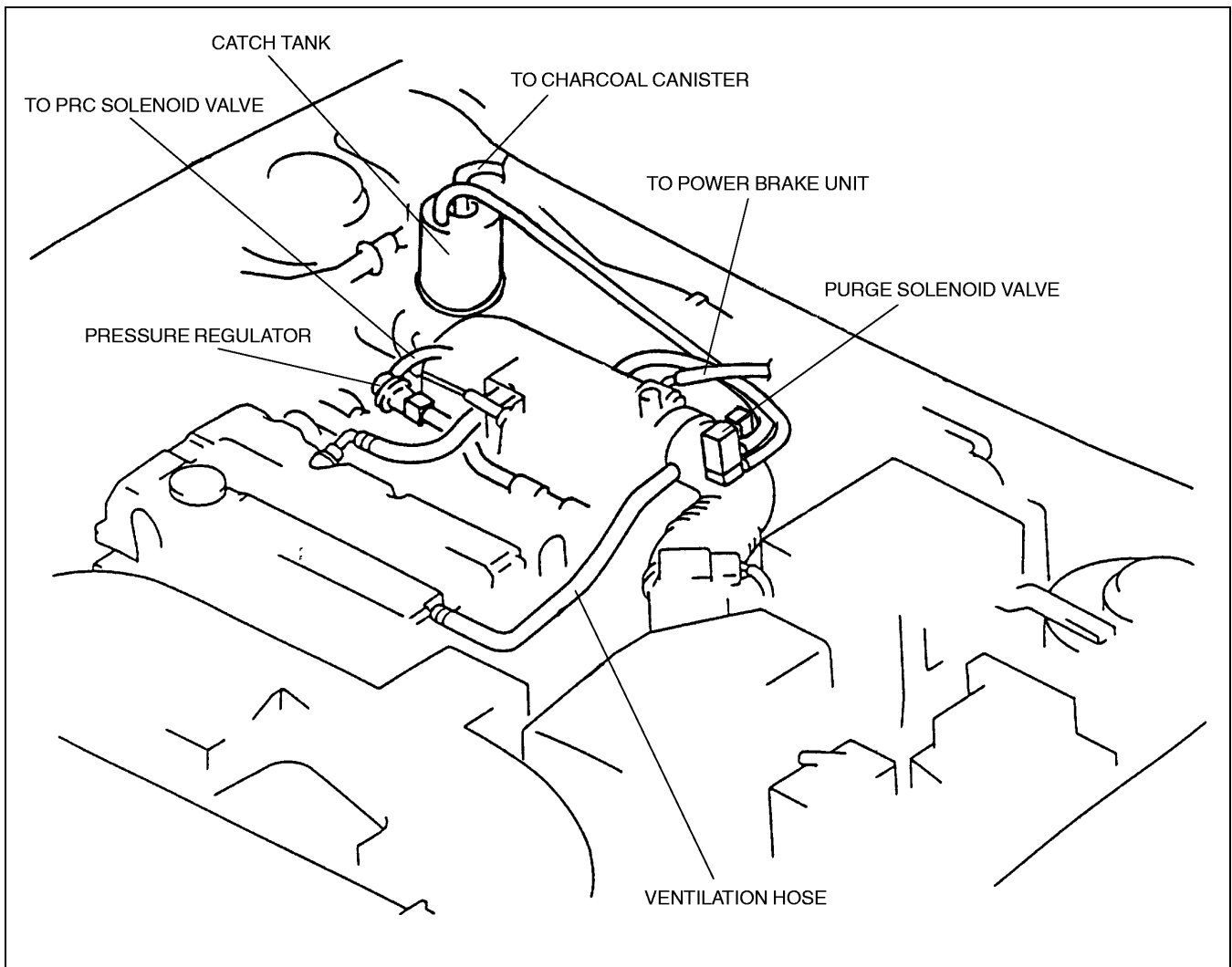

Y3U113WA5



# INTAKE-AIR SYSTEM [ZM]

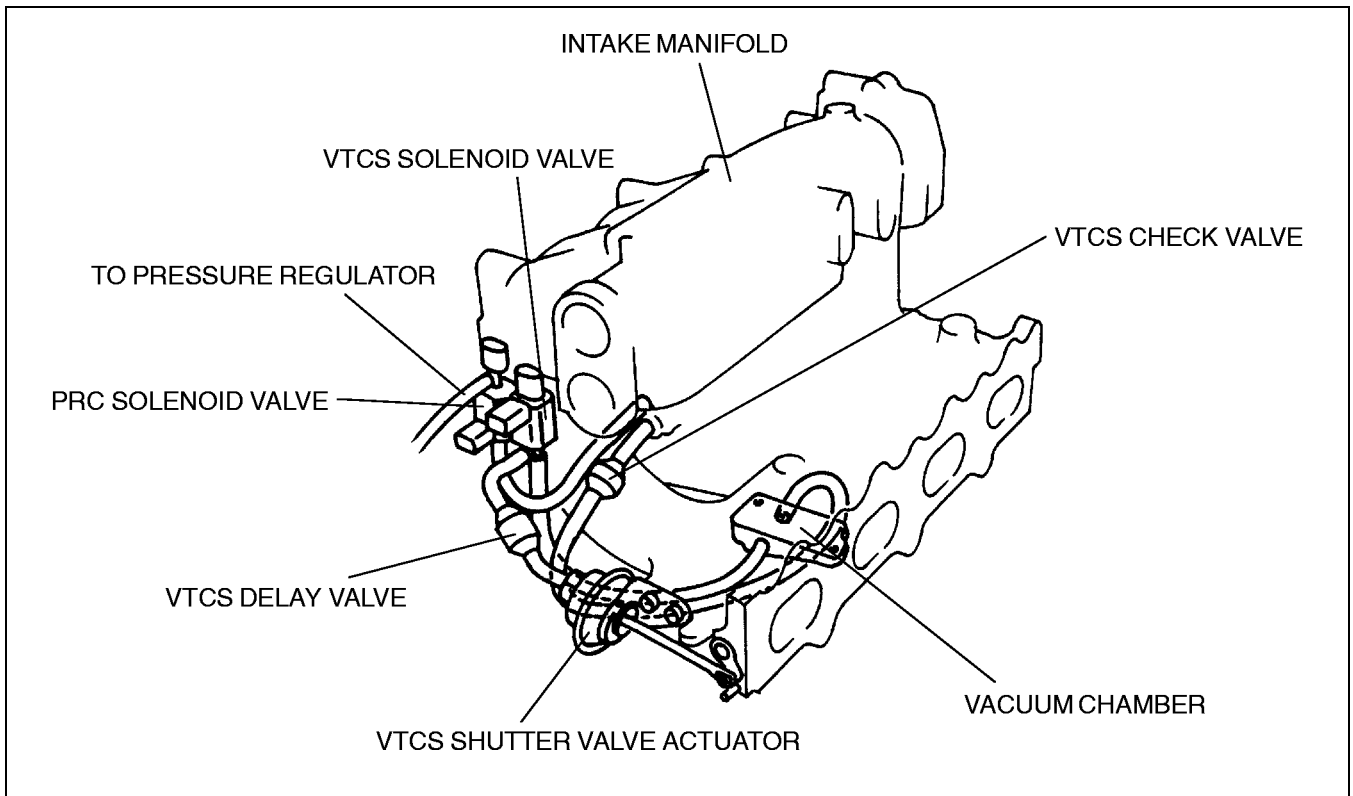

Z3U0113W015

# INTAKE-AIR SYSTEM [ZM]

## INTAKE-AIR SYSTEM REMOVAL/INSTALLATION [ZM]

A3U01131300W02

01-13A

### Warning

- When the engine and intake-air system are hot, they can badly burn. Turn off the engine and wait until they are cool before removing the intake-air system.
- Fuel vapor is hazardous. It can easily ignite, causing serious injury and damage. Always keep sparks and flames away from fuel.
- Fuel line spills and leakage are dangerous. Fuel can ignite and cause serious injuries or death and damage. Fuel can also irritate skin and eyes. To prevent this, always complete the "Fuel Line Safety Procedure". (See 01-14-4 BEFORE REPAIR PROCEDURE.)

1. Disconnect the negative battery cable.
2. Remove in the order indicated in the table.
3. Install in the reverse order of removal.

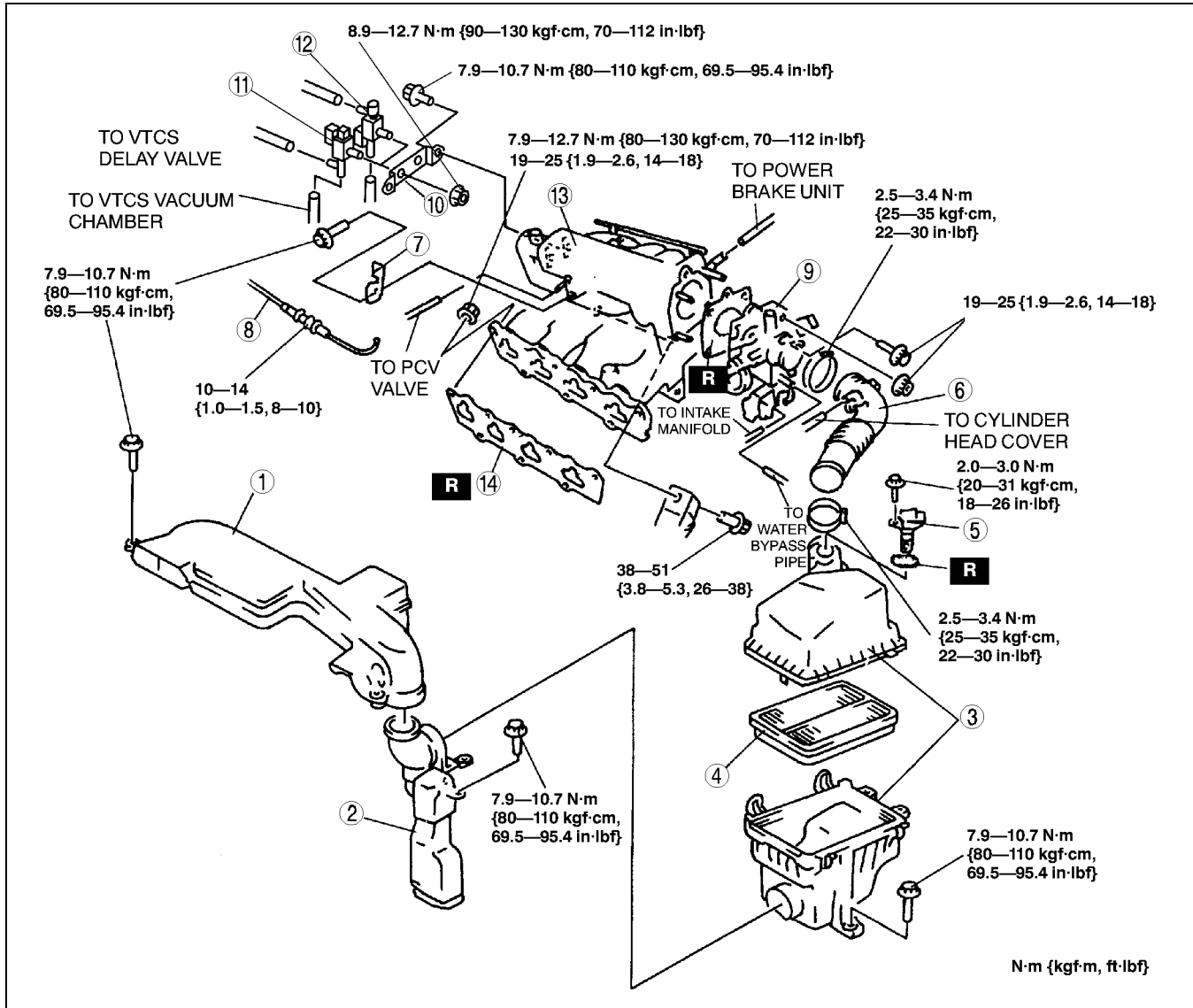

Z3U0113W003

1	Fresh-air duct
2	Resonance chamber
3	Air cleaner
4	Air cleaner element
5	MAF sensor (Integrated with IAT sensor)
6	Air hose
7	Accelerator cable bracket
8	Accelerator cable (See 01-13A-6 Accelerator Cable Installation Note)

9	Throttle body (See 01-13A-6 Throttle Body Removal Note) (See 01-13A-6 Throttle Body Installation Note)
10	VTCS solenoid valve bracket
11	VTCS solenoid valve
12	PRC solenoid valve
13	Intake manifold (See 01-13A-6 Intake Manifold Removal Note)

# INTAKE-AIR SYSTEM [ZM]

14	Intake manifold gasket (See 01-13A-6 Intake Manifold Gasket Installation Note)
----	---

## Throttle Body Removal Note

- Drain the engine coolant from the radiator. (See 01-12-3 ENGINE COOLANT REPLACEMENT.) (See 01-12-2 COOLING SYSTEM SERVICE WARNINGS.)

## Intake Manifold Removal Note

- Remove the fuel injector before removing the throttle body. (See 01-14-21 FUEL INJECTOR REMOVAL/INSTALLATION.)

## Intake Manifold Gasket Installation Note

- To install the intake manifold gasket, make sure that the convex side of the gasket is facing the intake manifold side.

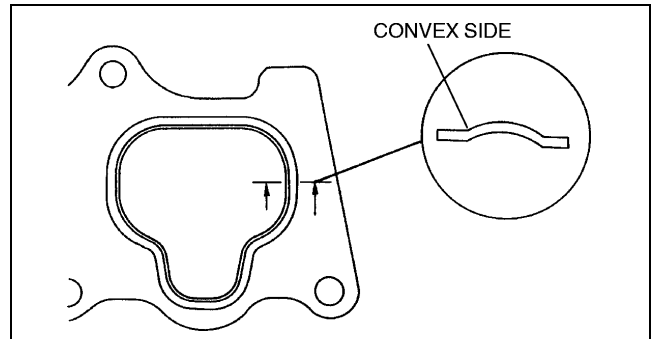

X3U113WA2

## Throttle Body Installation Note

- Refill the radiator with engine coolant after installing the throttle body. (See 01-12-3 ENGINE COOLANT REPLACEMENT.) (See 01-12-2 COOLING SYSTEM SERVICE WARNINGS.)

## Accelerator Cable Installation Note

- Carry out the "ACCELERATOR CABLE INSPECTION/ADJUSTMENT" procedure after installing the accelerator cable. (See 01-13A-13 ACCELERATOR CABLE INSPECTION/ADJUSTMENT [ZM].)

## IDLE AIR CONTROL (IAC) VALVE REMOVAL/INSTALLATION [ZM]

A3U011320661W03

1. Disconnect the negative battery cable.
2. Remove the air hose and throttle body. (See 01-13A-5 INTAKE-AIR SYSTEM REMOVAL/INSTALLATION [ZM].)
3. Disconnect the IAC valve connector.
4. Remove in the order indicated in the table.

1	Bolt
2	IAC valve

5. Install in the reverse order of removal.

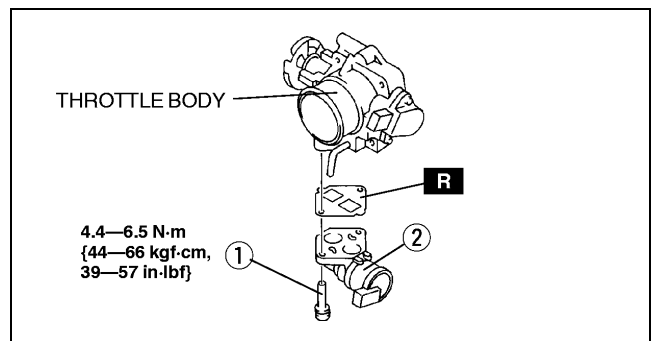

Y3U113WA2

## IDLE AIR CONTROL (IAC) VALVE INSPECTION [ZM]

A3U011320661W04

### Resistance Inspection

#### Note

- Perform the following test only as directed.

1. Carry out the "Idle Air Control (IAC) Inspection". (See 01-03A-57 Idle Air Control (IAC) Inspection.)
  - If not as specified, perform the further inspection for the IAC valve.
2. Disconnect the negative battery cable.
3. Disconnect the IAC valve connector.
4. Measure the resistance between the IAC valve terminals using an ohmmeter.
  - If not as specified, replace the IAC valve. (See 01-13A-6 IDLE AIR CONTROL (IAC) VALVE REMOVAL/INSTALLATION [ZM].)
  - If as specified, but PID value is failed, carry out the "Circuit Open/Short Inspection".
    - If there is an open or short circuit, repair or replace wiring harnesses.
    - If the above open or short circuit is okay, replace IAC valve.

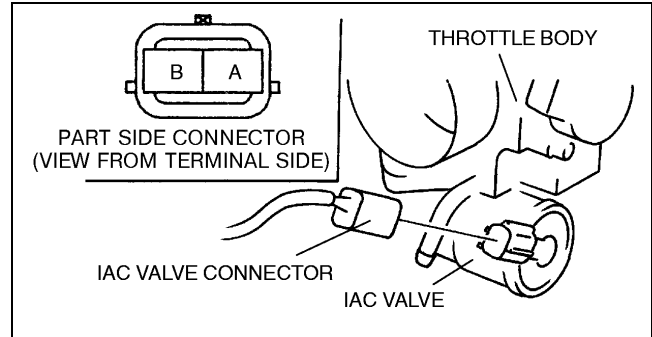

Y3U113WA3

### Resistance

**7.7—9.3 ohms [23 °C {73 °F}]**

### Circuit Open/Short Inspection

1. Remove the PCM. (See 01-40A-7 PCM REMOVAL/INSTALLATION [ZM].)
2. Connect the **SST** (104 Pin Breakout Box) to the PCM as shown.
3. Tighten the connector attaching screw.

### Tightening torque

**7.9—10.7 N·m {80—110 kgf·cm, 69.5—95.4 in·lbf}**

4. Inspect for an open or short circuit in the following wiring harnesses by probing the applicable sensor and **SST** (104 Pin Breakout Box) terminals with ohmmeter leads.

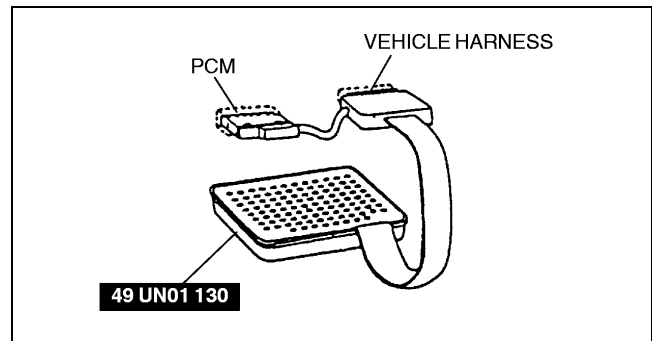

X3U113WAJ

### Open circuit

- Power circuit (IAC valve connector terminal A and PCM connector terminal 54)
- GND circuit (IAC valve connector terminal B and PCM connector terminal 83)

### Short circuit

- Power circuit (IAC valve connector terminal A and PCM connector terminal 54 to GND)
- GND circuit (IAC valve connector terminal B and PCM connector terminal 83 to GND)

5. Reconnect the IAC valve connector.
6. Reconnect the negative battery cable.

# INTAKE-AIR SYSTEM [ZM]

## VARIABLE TUMBLE CONTROL SYSTEM (VTCS) DIAGRAM [ZM]

A3U011313012W02

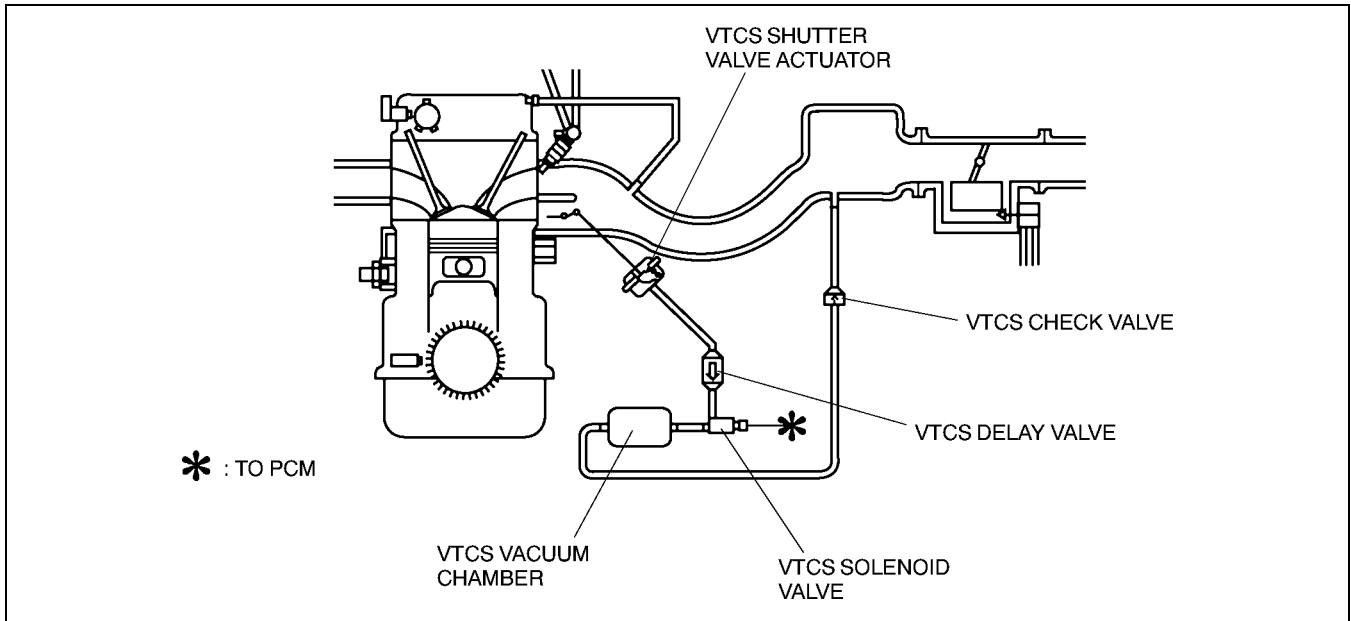

Z3U0113W004

## VARIABLE TUMBLE CONTROL SYSTEM (VTCS) CHECK VALVE (ONE-WAY) REMOVAL/INSTALLATION [ZM]

A3U011342913W01

1. Disconnect the negative battery cable.
2. Remove the air hose, throttle body and intake manifold. (See 01-13A-5 INTAKE-AIR SYSTEM REMOVAL/INSTALLATION [ZM].)
3. Remove in the order indicated in the table.

1	Vacuum hose
2	VTCS check valve (one-way)

4. Install in the reverse order of removal.

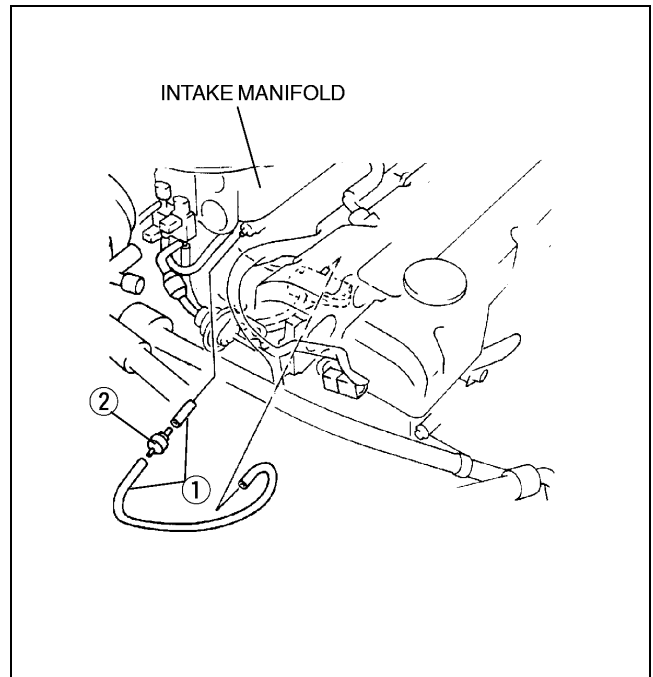

X3U113WA5

## INTAKE-AIR SYSTEM [ZM]

### VARIABLE TUMBLE CONTROL SYSTEM (VTCS) CHECK VALVE (ONE-WAY) INSPECTION [ZM]

A3U011342913W02

1. Remove the VTCS check valve (one-way). (See 01-13A-8 VARIABLE TUMBLE CONTROL SYSTEM (VTCS) CHECK VALVE (ONE-WAY) REMOVAL/INSTALLATION [ZM].)
2. Blow through port A and verify that the air flows from port B.
  - If not as specified, replace the VTCS check valve (one-way).
3. Blow through port B and verify that the air does not flow from port A.
  - If not as specified, replace the VTCS check valve (one-way).

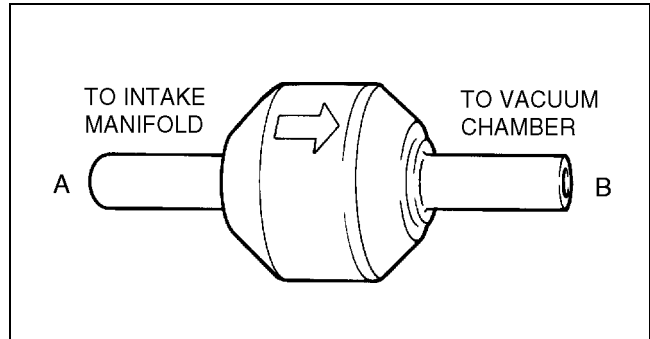

Z3U0113W999

01-13A

### VARIABLE TUMBLE CONTROL SYSTEM (VTCS) SHUTTER VALVE ACTUATOR REMOVAL/INSTALLATION [ZM]

A3U011320153W03

1. Disconnect the negative battery cable.
2. Remove the air hose, throttle body and intake manifold. (See 01-13A-5 INTAKE-AIR SYSTEM REMOVAL/INSTALLATION [ZM].)
3. Remove in the order indicated in the table.

1	E-ring
2	Bolt
3	VTCS shutter valve actuator

4. Install in the reverse order of removal.

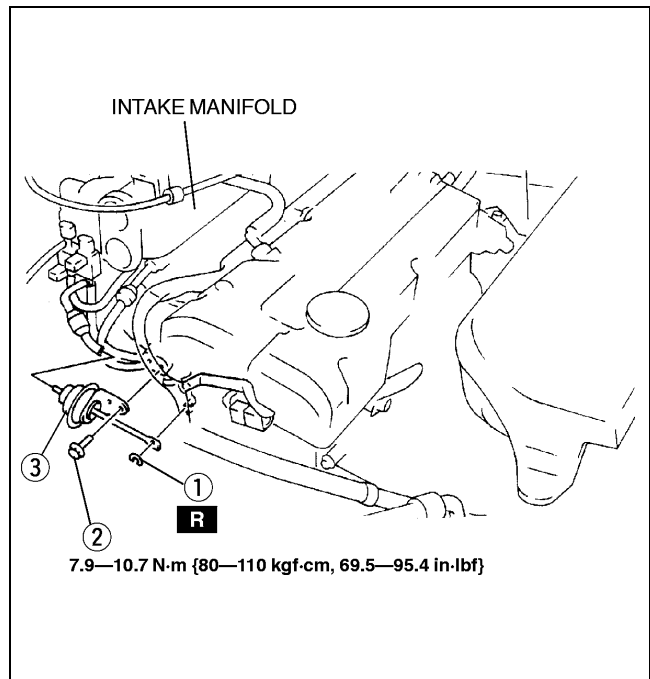

Y3U113WA6

# INTAKE-AIR SYSTEM [ZM]

## VARIABLE TUMBLE CONTROL SYSTEM (VTCS) SHUTTER VALVE ACTUATOR INSPECTION [ZM]

A3U011320153W04

### Operating Inspection

#### Note

- Perform the following test only as directed.

1. Carry out the "VTCS Operation Inspection". (See 01-03A-58 Variable Tumble Control System (VTCS) Inspection.)
  - If not as specified, perform the further inspection for the VTCS shutter valve actuator.
2. Disconnect the vacuum hose from the VTCS shutter valve actuator.
3. Connect a vacuum pump to the VTCS shutter valve actuator.
4. Apply pressure slowly and inspect the rod movement of the VTCS shutter valve actuator under the following condition.
  - If not as specified, replace the VTCS shutter valve actuator. (See 01-13A-9 VARIABLE TUMBLE CONTROL SYSTEM (VTCS) SHUTTER VALVE ACTUATOR REMOVAL/INSTALLATION [ZM].)
  - If as specified, but "VTCS Operation Inspection" is failed, inspect the vacuum hoses for improper routing, kinks or leakage, and inspect the following:

Pressure (kPa {mmHg, inHg})	Rod movement
Above -1.2 {-9.0, -0.35}	Not pulled
-3.6 -27.9 {-28 -209, -1.1 -8.2}	Start to move
Below -27.9 {-209, -8.2}	Fully pulled

5. Disconnect the vacuum pump to the VTCS shutter valve actuator.
6. Reconnect the vacuum hose from the VTCS shutter valve actuator.

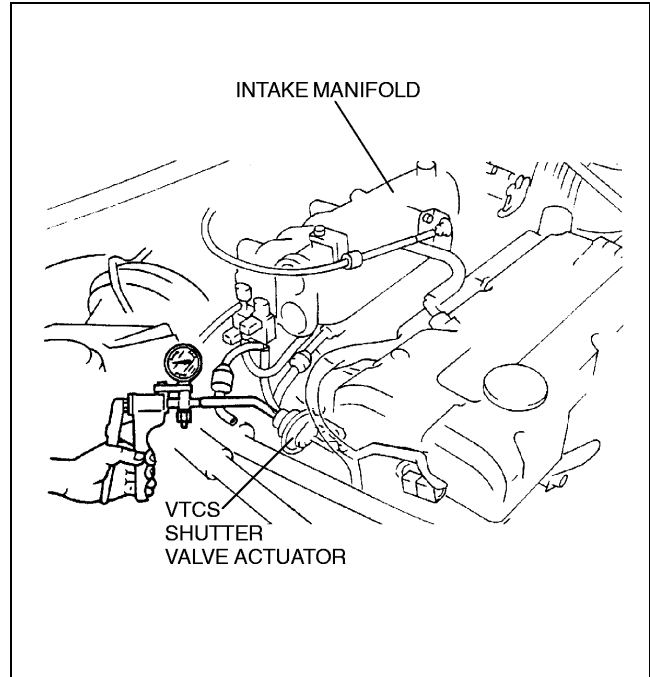

X3U113WA8

## VARIABLE TUMBLE CONTROL SYSTEM (VTCS) DELAY VALVE REMOVAL/INSTALLATION [ZM]

A3U011318800W03

1. Disconnect the negative battery cable.
2. Remove in the order indicated in the table.

1	Vacuum hose
2	VTCS delay valve

3. Install in the reverse order of removal.

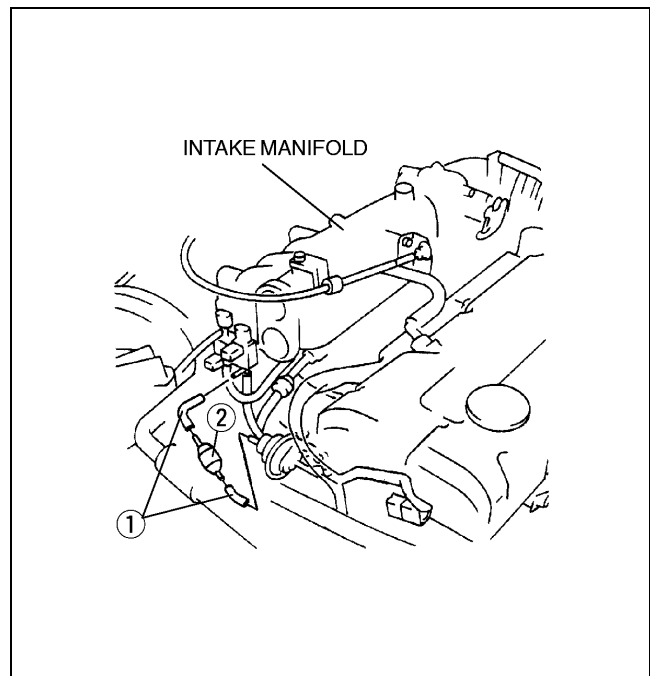

X3U113WA9

# INTAKE-AIR SYSTEM [ZM]

## VARIABLE TUMBLE CONTROL SYSTEM (VTCS) DELAY VALVE INSPECTION [ZM]

A3U011318800W04

1. Remove the VTCS delay valve. (See 01–13A–10 VARIABLE TUMBLE CONTROL SYSTEM (VTCS) DELAY VALVE REMOVAL/INSTALLATION [ZM].)
2. Blow through port A and verify that the air flows from port B.
  - If not as specified, replace the VTCS delay valve.
3. Blow through port B and verify that the air does not flow from port A.
  - If not as specified, replace the VTCS delay valve.

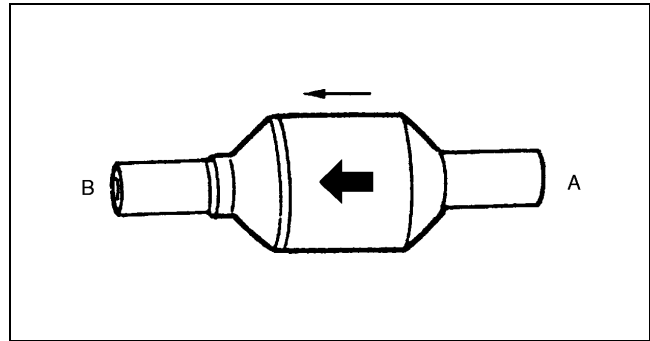

X3U113WAA

01-13A

## VARIABLE TUMBLE CONTROL SYSTEM (VTCS) SOLENOID VALVE INSPECTION [ZM]

A3U011318745W02

### Simulation Test

1. Carry out the “VTCS Operation Inspection”. (See 01–03A–58 Variable Tumble Control System (VTCS) Inspection.)
  - If not as specified, perform the further inspection for the VTCS solenoid valve.

### Airflow Inspection

#### Note

- Perform the following test only as directed.

1. Remove the VTCS solenoid valve.
2. Inspect airflow each port under the following condition.
  - If as specified, replace the VTCS solenoid valve.
  - If as specified but the “VTCS Operation Inspection” is failed, inspect evaporative hoses for improper routing, kinks or leakage, and “Circuit Open/Short Inspection”.
    - If there is an open or short circuit, repair or replace wiring harnesses.
    - If the above open or short circuit is okay, replace VTCS solenoid valve.

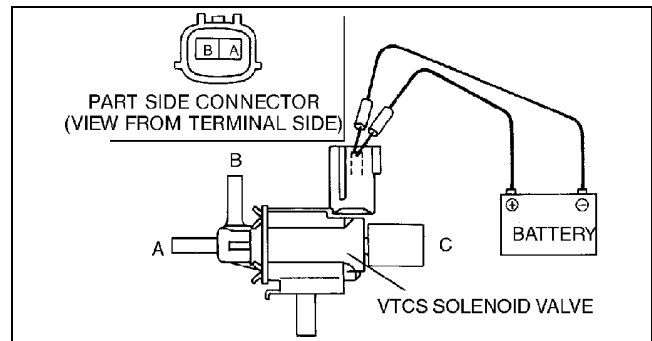

Y3U113WA4

○—○ : Continuity ○=○ : Airflow

Step	Terminal		Port		
	A	B	A	B	C
1	○—○	○—○		○=○	○=○
2	B+	GND	○—○	○=○	

X3U113WAI



## INTAKE-AIR SYSTEM [ZM]

### Circuit Open/Short Inspection

1. Remove the PCM. (See 01-40A-7 PCM REMOVAL/INSTALLATION [ZM].)
2. Connect the **SST** (104 Pin Breakout Box) to the PCM as shown.
3. Tighten the connector attaching screw.

#### Tightening torque

**7.9—10.7 N·m {80—110 kgf·cm, 69.5—95.4 in·lbf}**

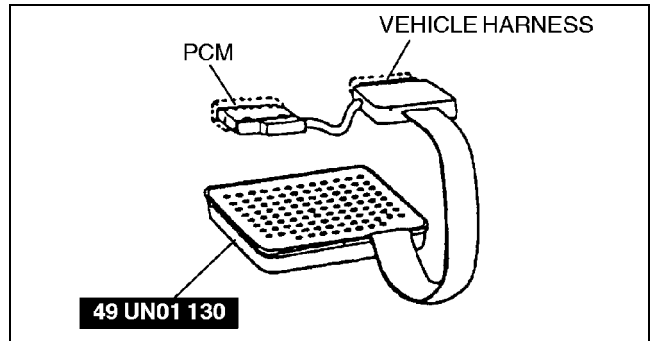

X3U113WAC

4. Inspect for an open or short circuit in the following wiring harnesses by probing the applicable sensor and **SST** (104 Pin Breakout Box) terminals with ohmmeter leads.

#### Open circuit

- Power circuit (VTCS solenoid valve connector terminal A and main relay connector terminal D through common connector)
- Control circuit (VTCS solenoid valve connector terminal B and PCM connector terminal 19)

#### Short circuit

- Power circuit (VTCS solenoid valve connector terminal A and main relay connector terminal D through common connector to GND)
- Control circuit (VTCS solenoid valve connector terminal B and PCM connector terminal 19 to GND)

5. Reconnect the VTCS solenoid valve connector.
6. Reconnect the negative battery cable.

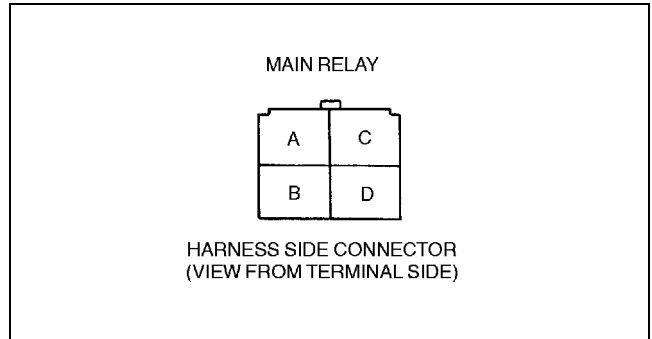

Z3U0113W998

## ACCELERATOR CABLE REMOVAL/INSTALLATION [ZM]

A3U011341660W04

#### Note

- Accelerator removal and installation on cruise control system-equipped vehicles is not possible.

1. Remove in the order indicated in the table.

1	Retainer
2	E-ring
3	Accelerator pedal (See 01-13A-13 Accelerator Pedal Installation Note)
4	Return spring

2. Install in the reverse order of removal.

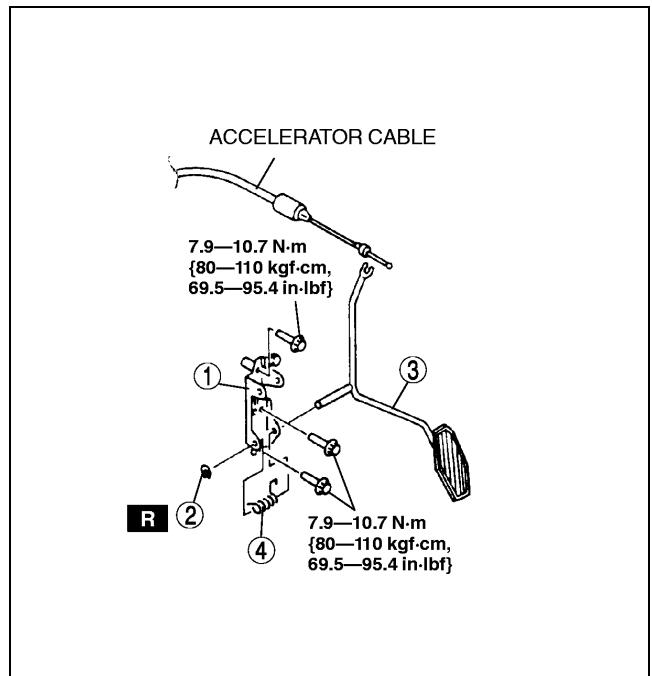

X3U113WAD

## INTAKE-AIR SYSTEM [ZM]

### Accelerator Pedal Installation Note

1. Set the accelerator pedal securely, taking care not to bend the accelerator cable.

### ACCELERATOR CABLE INSPECTION/ADJUSTMENT [ZM]

A3U011341660W05

1. Verify that the throttle valve is fully closed.
2. Pull the accelerator cable in A and B directions, and measure the free play.
  - If not as specified, adjust by turning locknuts C.

#### Free Play

1—3 mm {0.04—0.11 in}

#### Tightening torque

10—14 N·m {1.0—1.5 kgf·m, 8—10 ft·lbf}

01-13A

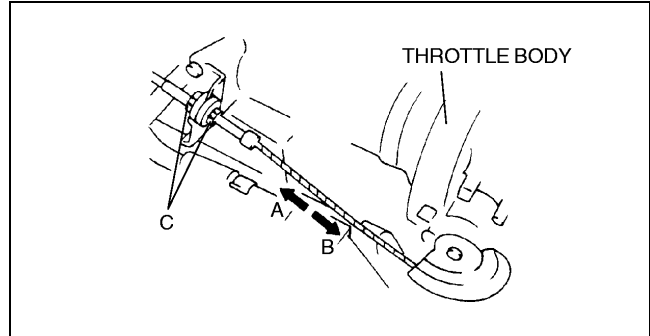

X3U113WAE

**01-13B INTAKE-AIR SYSTEM [FS]**

INTAKE-AIR SYSTEM LOCATION INDEX  
[FS] ..... 01-13B-2

INTAKE-AIR SYSTEM FLOW DIAGRAM  
[FS] ..... 01-13B-4

VACUUM HOSE ROUTING DIAGRAM  
[FS] ..... 01-13B-5

INTAKE-AIR SYSTEM REMOVAL/INSTALLATION  
[FS] ..... 01-13B-6

Throttle Body Removal Note ..... 01-13B-7

Intake Manifold Removal Note ..... 01-13B-7

Dynamic Chamber Gasket Installation Note  
..... 01-13B-7

Intake Manifold Gasket Installation Note 01-13B-7

Throttle Body Installation Note ..... 01-13B-7

Accelerator Cable Installation Note ... 01-13B-7

IDLE AIR CONTROL (IAC) VALVE REMOVAL/  
INSTALLATION [FS] ..... 01-13B-8

IDLE AIR CONTROL (IAC) VALVE  
INSPECTION [FS] ..... 01-13B-8

Resistance Inspection ..... 01-13B-8

Circuit Open/Short Inspection ..... 01-13B-9

VACUUM CHAMBER CHECK VALVE REMOVAL/  
INSTALLATION [FS] ..... 01-13B-9

VACUUM CHAMBER CHECK VALVE INSPECTION  
[FS] ..... 01-13B-9

VARIABLE INERTIA CHARGING SYSTEM (VICS)  
DIAGRAM [FS] ..... 01-13B-10

VARIABLE INERTIA CHARGING SYSTEM (VICS)  
CHECK VALVE (ONE-WAY) REMOVAL/  
INSTALLATION [FS] ..... 01-13B-10

VARIABLE INERTIA CHARGING SYSTEM (VICS)  
CHECK VALVE (ONE-WAY) INSPECTION  
[FS] ..... 01-13B-10

VARIABLE INERTIA CHARGING SYSTEM (VICS)  
SHUTTER VALVE ACTUATOR REMOVAL/  
INSTALLATION [FS] ..... 01-13B-11

VARIABLE INERTIA CHARGING SYSTEM (VICS)  
SHUTTER VALVE ACTUATOR INSPECTION  
[FS] ..... 01-13B-11

Operating Inspection ..... 01-13B-11

VARIABLE INERTIA CHARGING SYSTEM (VICS)  
SOLENOID VALVE INSPECTION [FS] . 01-13B-12

Airflow Inspection ..... 01-13B-12

Circuit Open/Short Inspection ..... 01-13B-12

VARIABLE TUMBLE CONTROL SYSTEM (VTCS)  
DIAGRAM [FS] ..... 01-13B-13

VARIABLE TUMBLE CONTROL SYSTEM (VTCS)  
SHUTTER VALVE ACTUATOR REMOVAL/  
INSTALLATION [FS] ..... 01-13B-13

VARIABLE TUMBLE CONTROL SYSTEM (VTCS)  
SHUTTER VALVE ACTUATOR INSPECTION  
[FS] ..... 01-13B-14

Operating Inspection ..... 01-13B-14

VARIABLE TUMBLE CONTROL SYSTEM (VTCS)  
DELAY VALVE REMOVAL/INSTALLATION  
[FS] ..... 01-13B-14

VARIABLE TUMBLE CONTROL SYSTEM (VTCS)  
DELAY VALVE INSPECTION [FS] .... 01-13B-15

VARIABLE TUMBLE CONTROL SYSTEM (VTCS)  
SOLENOID VALVE INSPECTION [FS] . 01-13B-15

Simulation Test ..... 01-13B-15

Airflow Inspection ..... 01-13B-15

Circuit Open/Short Inspection ..... 01-13B-16

ACCELERATOR CABLE REMOVAL/  
INSTALLATION [FS] ..... 01-13B-16

Accelerator Pedal Installation Note ... 01-13B-17

ACCELERATOR CABLE INSPECTION  
[FS] ..... 01-13B-17

ACCELERATOR CABLE ADJUSTMENT  
[FS] ..... 01-13B-17

01-13B

# INTAKE-AIR SYSTEM [FS]

## INTAKE-AIR SYSTEM LOCATION INDEX [FS]

A3U011301005W01

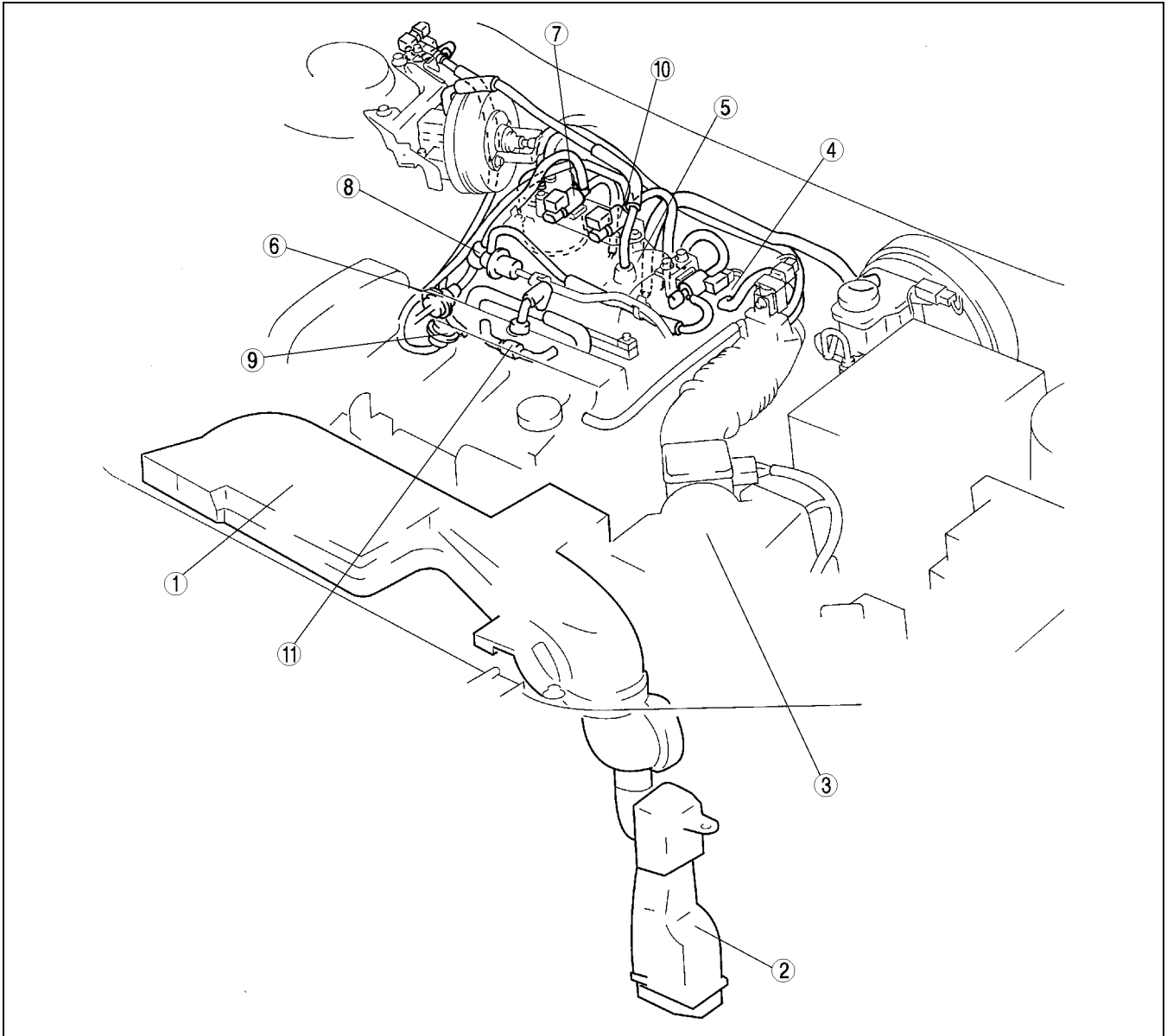

Z3U0113W005

1	Fresh-air duct (See 01-13B-6 INTAKE-AIR SYSTEM REMOVAL/ INSTALLATION [FS])
2	Resonance chamber (See 01-13B-6 INTAKE-AIR SYSTEM REMOVAL/ INSTALLATION [FS])
3	Air cleaner (See 01-13B-6 INTAKE-AIR SYSTEM REMOVAL/ INSTALLATION [FS])
4	Throttle body (See 01-13B-6 INTAKE-AIR SYSTEM REMOVAL/ INSTALLATION [FS])
5	Intake manifold (See 01-13B-6 INTAKE-AIR SYSTEM REMOVAL/ INSTALLATION [FS])

6	VTCS shutter valve actuator (See 01-13B-13 VARIABLE TUMBLE CONTROL SYSTEM (VTCS) SHUTTER VALVE ACTUATOR REMOVAL/INSTALLATION [FS]) (See 01-13B-14 VARIABLE TUMBLE CONTROL SYSTEM (VTCS) SHUTTER VALVE ACTUATOR INSPECTION [FS])
7	VTCS solenoid valve (See 01-13B-6 INTAKE-AIR SYSTEM REMOVAL/ INSTALLATION [FS]) (See 01-13B-15 VARIABLE TUMBLE CONTROL SYSTEM (VTCS) SOLENOID VALVE INSPECTION [FS])
8	VTCS delay valve (See 01-13B-14 VARIABLE TUMBLE CONTROL SYSTEM (VTCS) DELAY VALVE REMOVAL/ INSTALLATION [FS]) (See 01-13B-15 VARIABLE TUMBLE CONTROL SYSTEM (VTCS) DELAY VALVE INSPECTION [FS])

## INTAKE-AIR SYSTEM [FS]

9	VICS shutter valve actuator (See 01-13B-11 VARIABLE INERTIA CHARGING SYSTEM (VICS) SHUTTER VALVE ACTUATOR REMOVAL/INSTALLATION [FS]) (See 01-13B-11 VARIABLE INERTIA CHARGING SYSTEM (VICS) SHUTTER VALVE ACTUATOR INSPECTION [FS])
---	---

10	VICS solenoid valve (See 01-13B-6 INTAKE-AIR SYSTEM REMOVAL/INSTALLATION [FS]) (See 01-13B-12 VARIABLE INERTIA CHARGING SYSTEM (VICS) SOLENOID VALVE INSPECTION [FS])
11	Vacuum chamber check valve (See 01-13B-9 VACUUM CHAMBER CHECK VALVE REMOVAL/INSTALLATION [FS]) (See 01-13B-9 VACUUM CHAMBER CHECK VALVE INSPECTION [FS])

01-13B

# INTAKE-AIR SYSTEM [FS]

## INTAKE-AIR SYSTEM FLOW DIAGRAM [FS]

A3U011301005W02

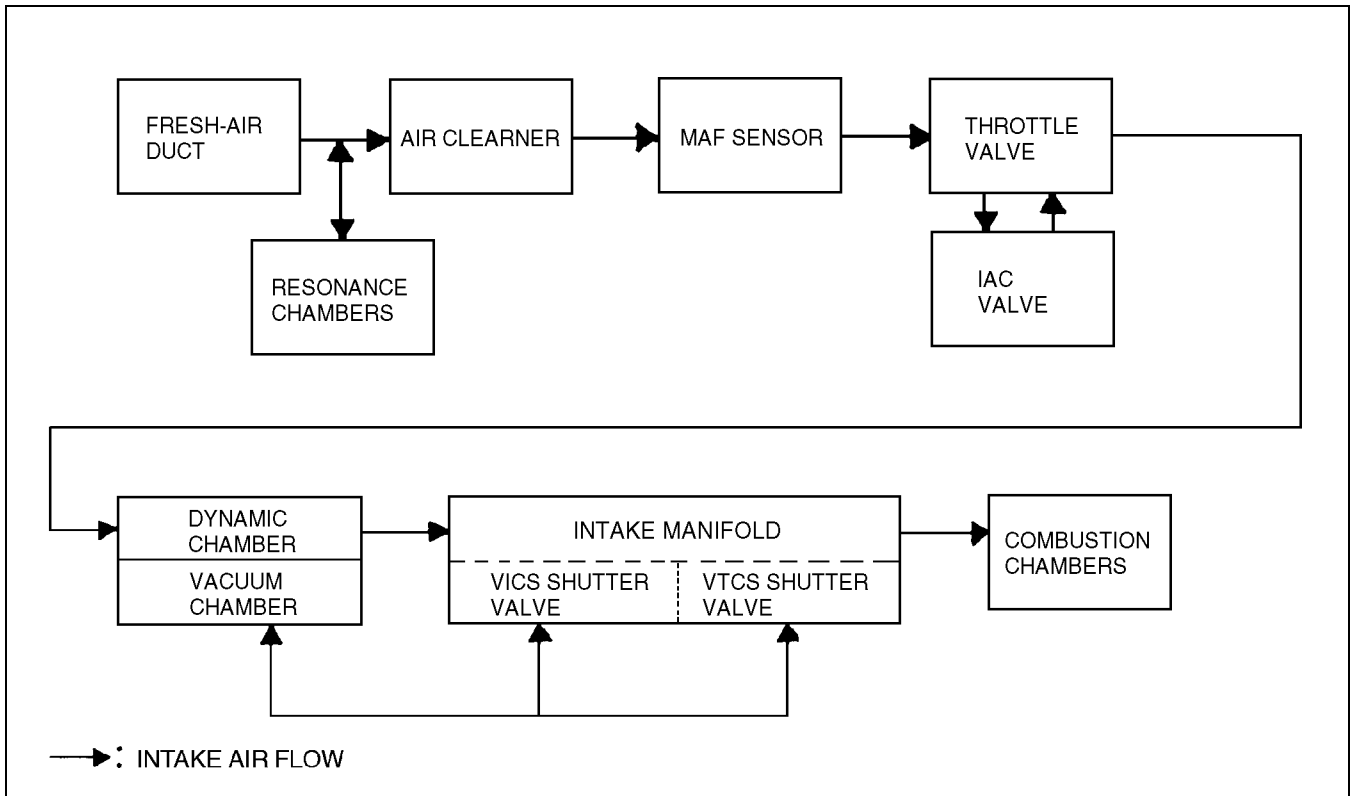

Z3U0113W006

# INTAKE-AIR SYSTEM [FS]

## VACUUM HOSE ROUTING DIAGRAM [FS]

A3U011320030W01

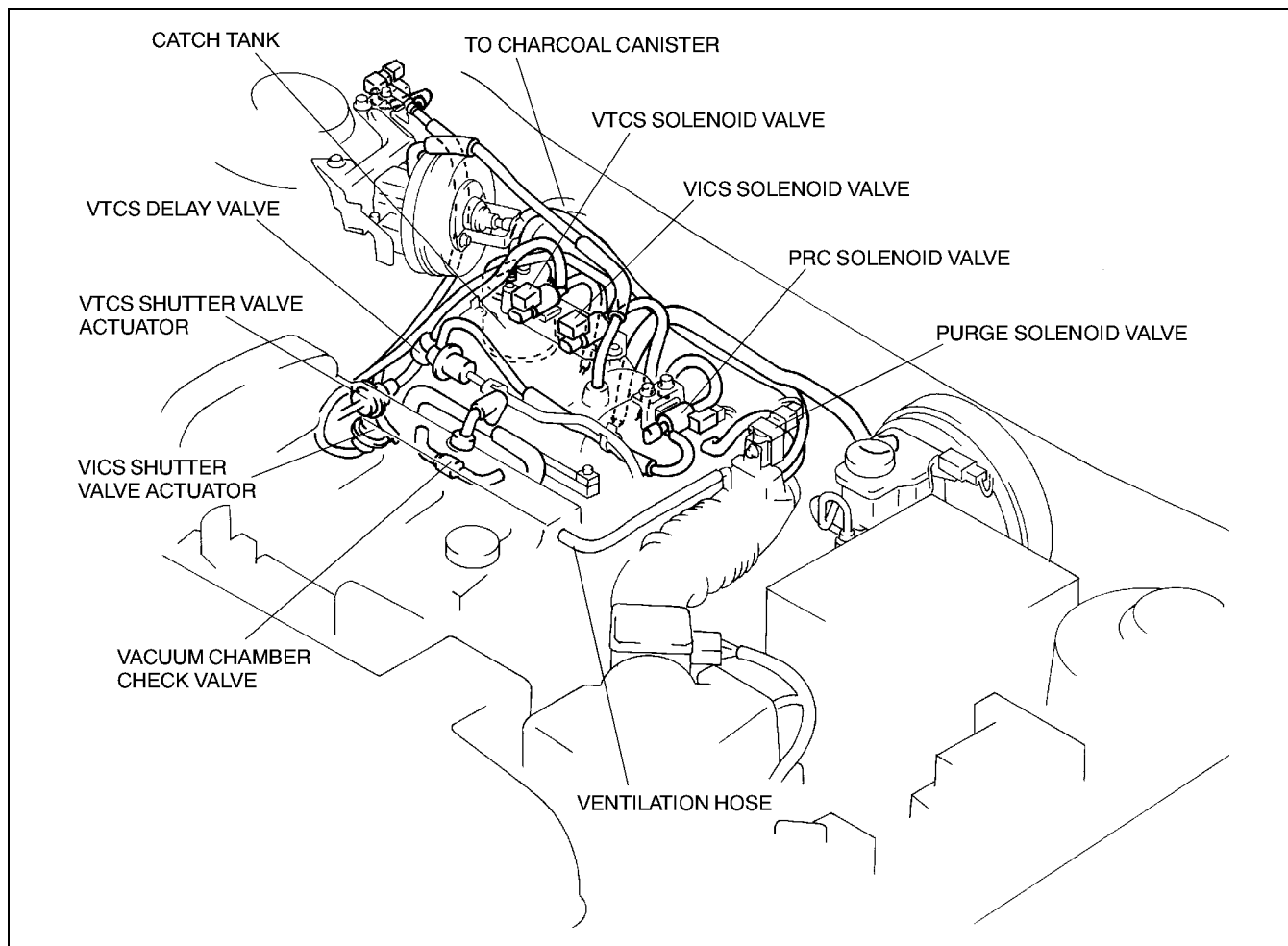

01-13B

Z3U0113W007

# INTAKE-AIR SYSTEM [FS]

## INTAKE-AIR SYSTEM REMOVAL/INSTALLATION [FS]

A3U011313000W01

### Warning

- When the engine and intake-air system are hot, they can badly burn. Turn off the engine and wait until they are cool before removing the intake-air system.
- Fuel vapor is hazardous. It can easily ignite, causing serious injury and damage. Always keep sparks and flames away from fuel.
- Fuel line spills and leakage are dangerous. Fuel can ignite and cause serious injuries or death and damage. Fuel can also irritate skin and eyes. To prevent this, always complete the "Fuel Line Safety Procedure". (See 01-14-4 BEFORE REPAIR PROCEDURE.)

1. Disconnect the battery negative cable.
2. Remove in the order indicated in the table.
3. Install in the reverse order of removal.

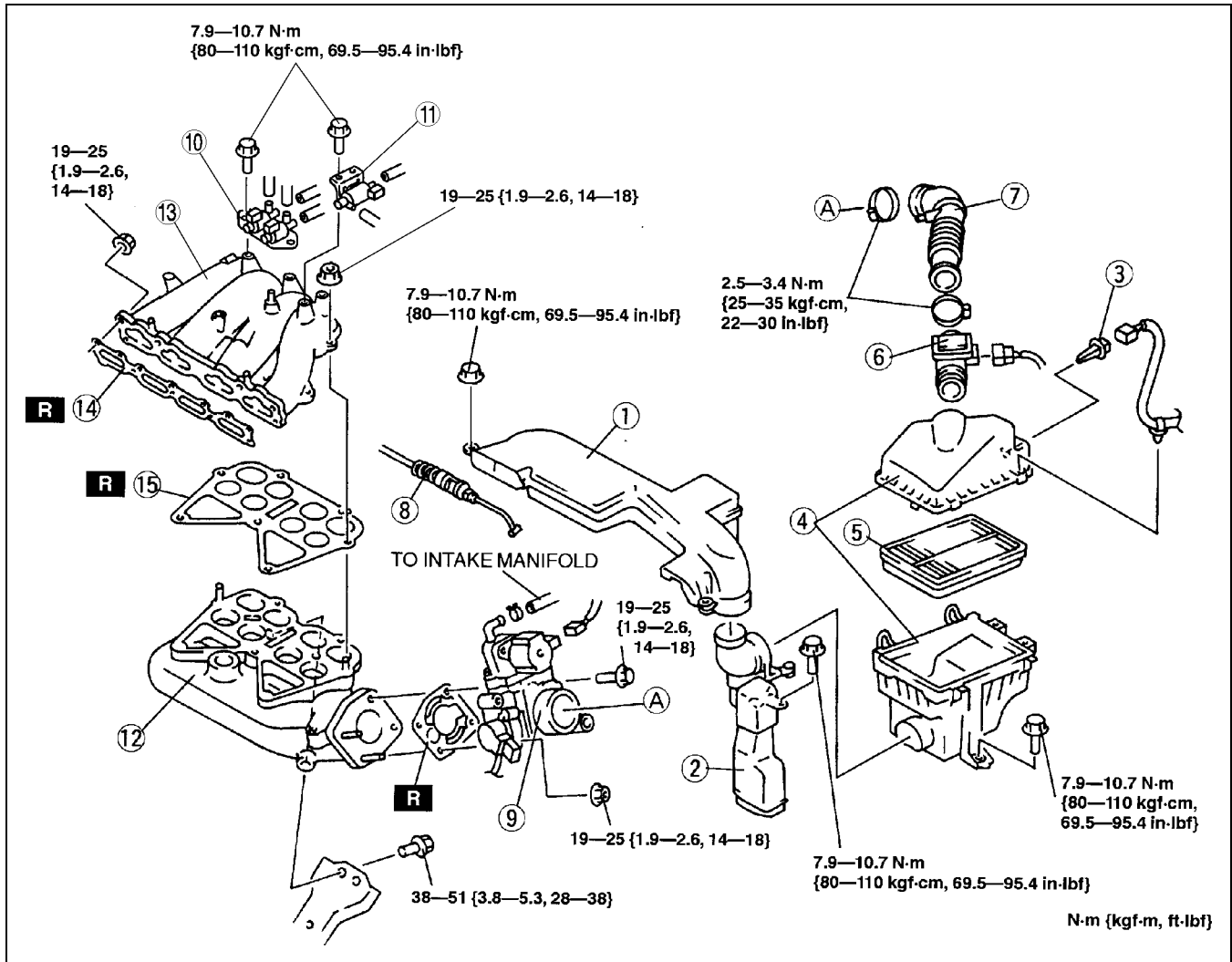

Z3U0113W008

1	Fresh-air duct
2	Resonance chamber
3	IAT sensor
4	Air cleaner
5	Air cleaner element
6	MAF sensor
7	Air hose
8	Accelerator cable (See 01-13B-7 Accelerator Cable Installation Note)
9	Throttle body (See 01-13B-7 Throttle Body Removal Note) (See 01-13B-7 Throttle Body Installation Note)

10	Solenoid valve bracket
11	PRC solenoid valve
12	Dynamic chamber
13	Intake manifold (See 01-13B-7 Intake Manifold Removal Note)
14	Intake manifold gasket (See 01-13B-7 Intake Manifold Gasket Installation Note)
15	Dynamic chamber gasket (See 01-13B-7 Dynamic Chamber Gasket Installation Note)



## INTAKE-AIR SYSTEM [FS]

### Throttle Body Removal Note

1. Drain the engine coolant from the radiator before removing the throttle body. (See 01-12-3 ENGINE COOLANT REPLACEMENT.) (See 01-12-2 COOLING SYSTEM SERVICE WARNINGS.)

### Intake Manifold Removal Note

1. Remove the fuel injector before removing the intake manifold. (See 01-14-21 FUEL INJECTOR REMOVAL/INSTALLATION.)

### Dynamic Chamber Gasket Installation Note

1. To install the dynamic chamber gasket, make sure that the convex side of the gasket is facing the intake manifold side.

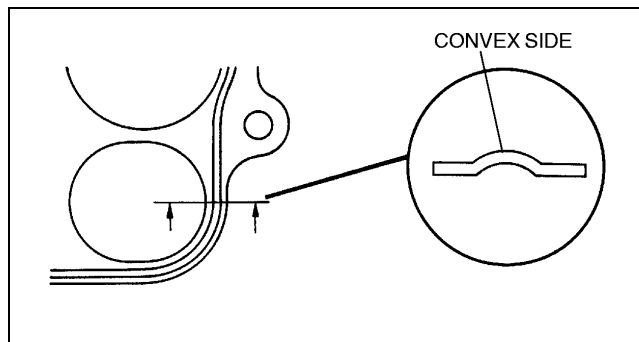

### Intake Manifold Gasket Installation Note

1. To install the intake manifold gasket, make sure that the convex side of the gasket is facing the intake manifold side.

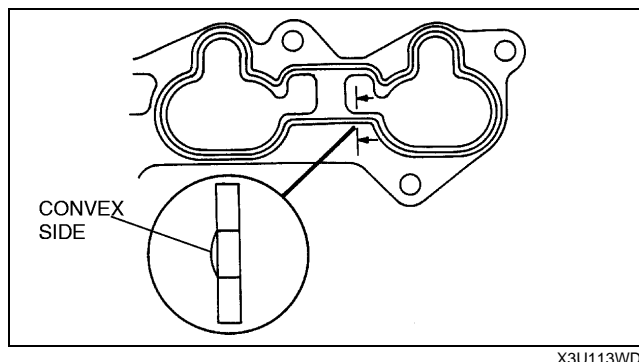

### Throttle Body Installation Note

1. Refill the radiator with engine coolant after installing the throttle body. (See 01-12-3 ENGINE COOLANT REPLACEMENT.) (See 01-12-2 COOLING SYSTEM SERVICE WARNINGS.)

### Accelerator Cable Installation Note

1. Carry out the "ACCELERATOR CABLE INSPECTION/ADJUSTMENT" procedure after installing the accelerator cable. (See 01-13B-17 ACCELERATOR CABLE INSPECTION [FS].) (See 01-13B-17 ACCELERATOR CABLE ADJUSTMENT [FS].)

01-13B

# INTAKE-AIR SYSTEM [FS]

## IDLE AIR CONTROL (IAC) VALVE REMOVAL/INSTALLATION [FS]

A3U011320661W01

1. Disconnect the battery negative cable.
2. Remove the air hose and throttle body. (See 01-13B-6 INTAKE-AIR SYSTEM REMOVAL/INSTALLATION [FS].)
3. Disconnect the IAC valve connector.
4. Remove in the order indicated in the table.

1	Bolt
2	IAC valve

5. Install in the reverse order of removal.

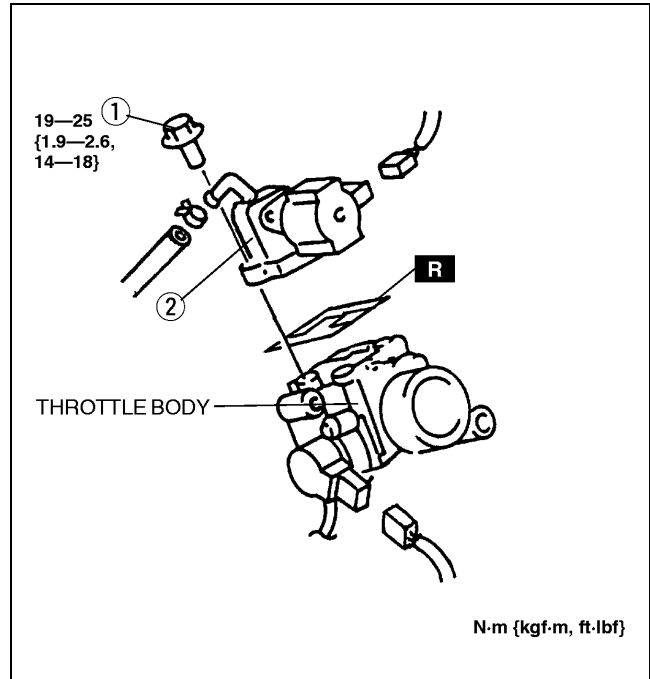

X3U113WD5

## IDLE AIR CONTROL (IAC) VALVE INSPECTION [FS]

A3U011320661W02

### Resistance Inspection

#### Note

- Perform the following test only as directed.

1. Carry out the “Idle Air Control (IAC) Inspection”. (See 01-03B-56 Idle Air Control (IAC) Inspection.)
  - If not as specified, perform the further inspection for the IAC valve.
2. Disconnect the battery negative cable.
3. Disconnect the IAC valve connector.
4. Measure the resistance between the IAC valve terminals using an ohmmeter.
  - If not as specified, replace the IAC valve. (See 01-13B-8 IDLE AIR CONTROL (IAC) VALVE REMOVAL/INSTALLATION [FS].)
  - If as specified, but PID value failed, carry out the “Circuit Open/Short inspection”.
    - If there is an open or short circuit, repair or replace wiring harnesses.
    - If there is no open or short circuit, replace IAC valve.

#### Resistance

7.7—9.3 ohms [23 °C {73 °F}]

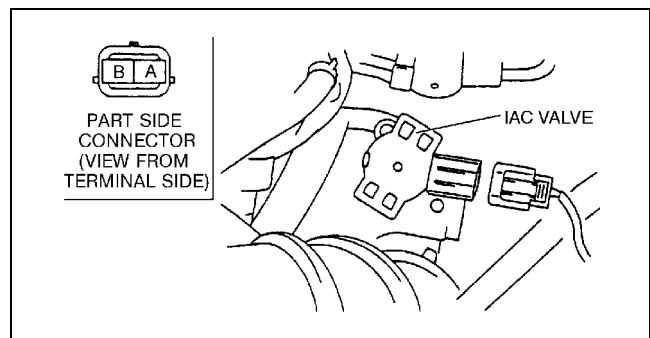

Z3U0113W997

## INTAKE-AIR SYSTEM [FS]

### Circuit Open/Short Inspection

1. Disconnect the PCM connector. (See 01-40B-7 PCM REMOVAL/INSTALLATION [FS].)
2. Connect the **SST** (104 Pin Breakout Box) to the PCM as shown.
3. Tighten the connector attaching screw.

#### Tightening torque

7.9—10.7 N·m

{80—110 kgf·cm, 69.5—95.4 in·lbf}

4. Inspect for an open or short circuit in the following wiring harnesses by probing the applicable sensor and **SST** (104 Pin Breakout Box) terminals with ohmmeter leads.

#### Open circuit

- Power circuit (IAC valve connector terminal A and PCM connector terminal 54)
- GND circuit (IAC valve connector terminal B and PCM connector terminal 83)

#### Short circuit

- Power circuit (IAC valve connector terminal A and PCM connector terminal 54 to GND)
- GND circuit (IAC valve connector terminal B and PCM connector terminal 83 to GND)

5. Reconnect the IAC valve connector.
6. Reconnect the battery negative cable.

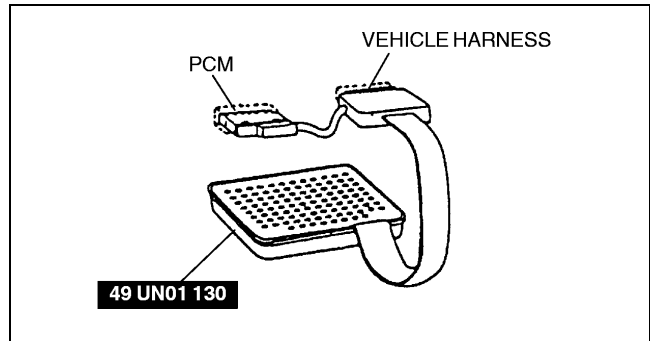

X3U113WDG

01-13B

### VACUUM CHAMBER CHECK VALVE REMOVAL/INSTALLATION [FS]

A3U011342910W01

1. Disconnect the battery negative cable.
2. Remove the air hose, throttle body and intake manifold. (See 01-13B-6 INTAKE-AIR SYSTEM REMOVAL/INSTALLATION [FS].)
3. Remove in the order indicated in the table.
4. Install in the reverse order of removal.

1	Vacuum hose
2	Vacuum chamber check valve

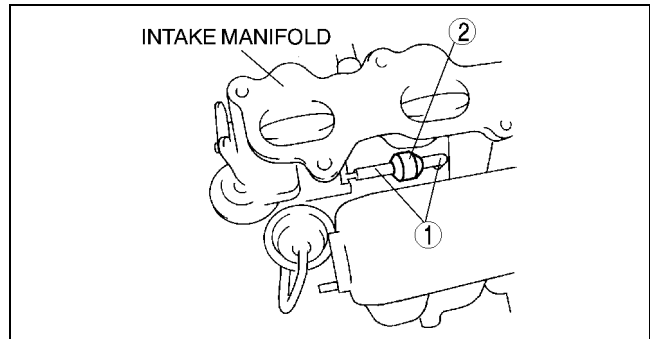

Z3U0113W009

### VACUUM CHAMBER CHECK VALVE INSPECTION [FS]

A3U011342910W02

1. Remove the vacuum chamber check valve. (See 01-13B-9 VACUUM CHAMBER CHECK VALVE REMOVAL/INSTALLATION [FS].)
2. Blow through port A and verify that the air flows from port B.
  - If not as specified, replace the vacuum chamber check valve.
3. Blow through port B and verify that the air does not flow from port A.
  - If not as specified, replace the vacuum chamber check valve.

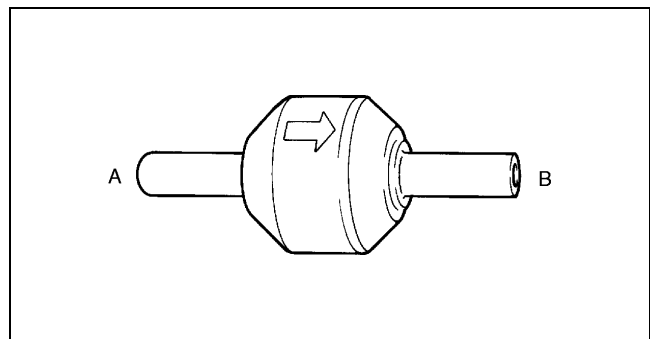

X3U113WD8

# INTAKE-AIR SYSTEM [FS]

## VARIABLE INERTIA CHARGING SYSTEM (VICS) DIAGRAM [FS]

A3U011313011W01

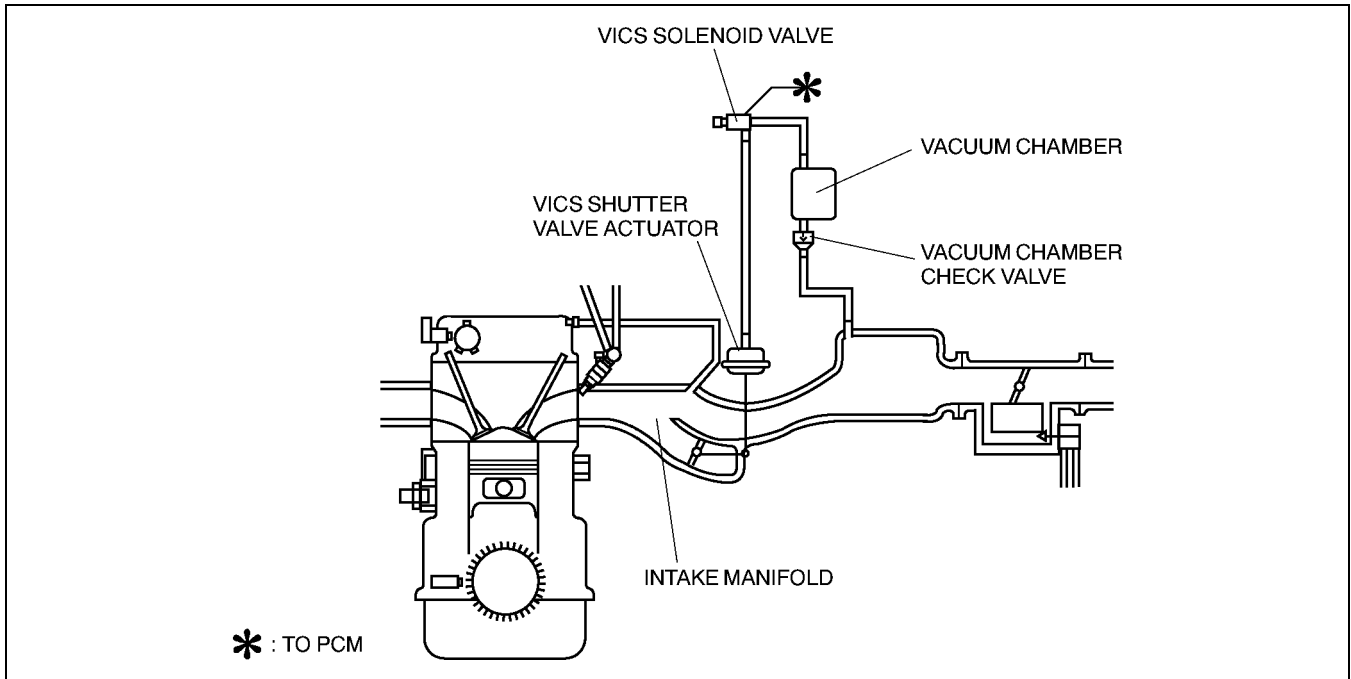

Z3U0113W010

## VARIABLE INERTIA CHARGING SYSTEM (VICS) CHECK VALVE (ONE-WAY) REMOVAL/INSTALLATION [FS]

A3U011313995W01

1. Disconnect the negative battery cable.
2. Remove the air hose, throttle body and intake manifold. (See 01-13B-6 INTAKE-AIR SYSTEM REMOVAL/INSTALLATION [FS].)
3. Remove in the order indicated in the table.

1	Vacuum hose
2	VICS check valve (one-way)

4. Install in the reverse order of removal.

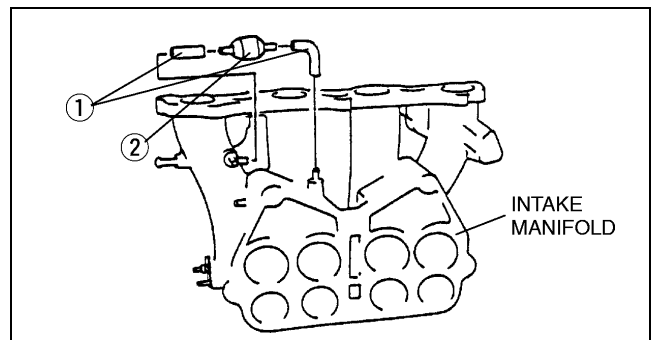

X3U113WD7

## VARIABLE INERTIA CHARGING SYSTEM (VICS) CHECK VALVE (ONE-WAY) INSPECTION [FS]

A3U011313995W02

1. Remove the VICS check valve (one-way). (See 01-13B-10 VARIABLE INERTIA CHARGING SYSTEM (VICS) CHECK VALVE (ONE-WAY) REMOVAL/INSTALLATION [FS].)
2. Blow through port A and verify that the air flows from port B.
  - If not as specified, replace the VICS check valve (one-way).
3. Blow through port B and verify that the air does not flow from port A.
  - If not as specified, replace the VICS check valve (one-way).

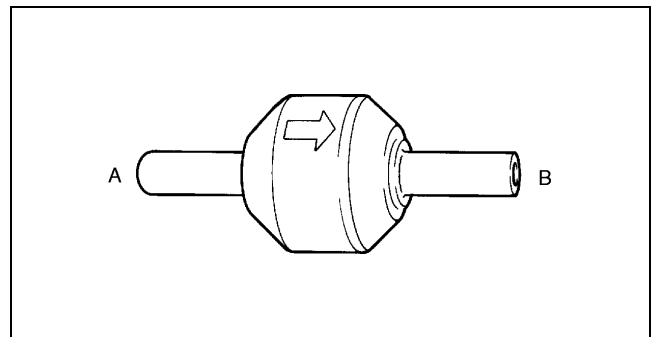

X3U113WD8

## INTAKE-AIR SYSTEM [FS]

### VARIABLE INERTIA CHARGING SYSTEM (VICS) SHUTTER VALVE ACTUATOR REMOVAL/INSTALLATION [FS]

A3U011320152W01

1. Disconnect the battery negative cable.
2. Remove in the order indicated in the table.

1	E ring
2	Bolt
3	VICS shutter valve actuator

3. Install in the reverse order of removal.

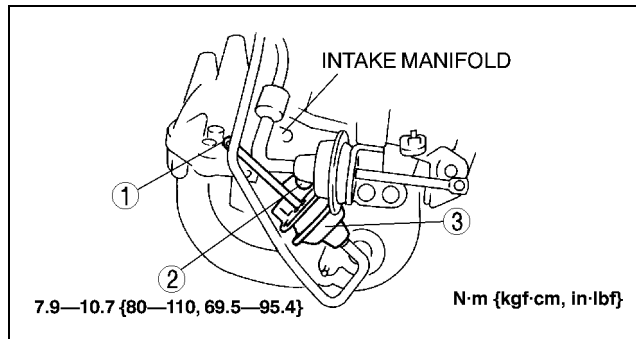

Z3U0113W011

01-13B

### VARIABLE INERTIA CHARGING SYSTEM (VICS) SHUTTER VALVE ACTUATOR INSPECTION [FS]

A3U011320152W02

#### Operating Inspection

##### Note

- Perform the following test only as directed.

1. Carry out the "VICS Operation Inspection". (See 01-03B-57 VICS Operation Inspection.)
  - If not as specified, perform the further inspection for the VICS shutter valve actuator.
2. Disconnect the vacuum hose from the VICS shutter valve actuator.
3. Connect a vacuum pump to the VICS shutter valve actuator.
4. Apply pressure slowly and inspect the rod movement of the VICS shutter valve actuator under the following condition.
  - If not as specified, replace the VICS shutter valve actuator. (See 01-13B-11 VARIABLE INERTIA CHARGING SYSTEM (VICS) SHUTTER VALVE ACTUATOR REMOVAL/INSTALLATION [FS].)
  - If as specified, but "VICS Operation Inspection" failed, inspect the vacuum hoses for proper routing, kinks or leakage.

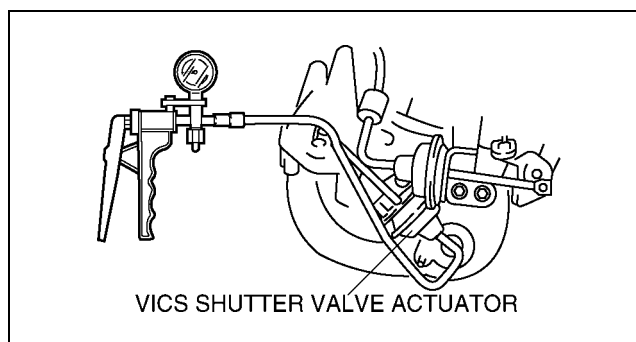

Z3U0113W017

Pressure (kPa {mmHg, inHg})	Rod movement
Above -2.7 {-20, -0.80}	Not pulled
-8.0—-35.3 {-61—-264, -2.4—-10.4}	Starts to move
Below -35.3 {-265, -10.4}	Fully pulled

5. Disconnect the vacuum pump from the VICS shutter valve actuator.
6. Reconnect the vacuum hose to the VICS shutter valve actuator.

# INTAKE-AIR SYSTEM [FS]

## VARIABLE INERTIA CHARGING SYSTEM (VICS) SOLENOID VALVE INSPECTION [FS]

A3U011318740W01

### Airflow Inspection

#### Note

- Perform the following test only as directed.

1. Carry out the "VICS Operation Inspection". (See 01-03B-57 VICS Operation Inspection.)
  - If not as specified, perform the further inspection for the VICS solenoid valve.
2. Disconnect the battery negative cable.
3. Remove the VICS solenoid valve.
4. Inspect for airflow between each port under the following condition.
  - If not as specified, replace the VICS solenoid valve.
  - If as specified but the "VICS Operation Inspection" failed, carry out the "Circuit Open/Short Inspection".
    - If there is an open or short circuit, repair or replace wiring harnesses.
    - If there is no open or short circuit, replace VICS solenoid valve.

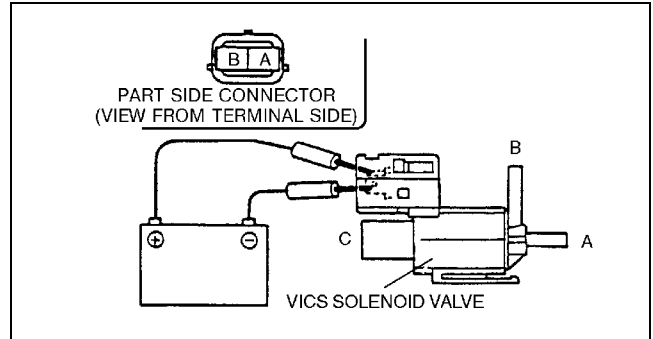

Y3U113WAB

○—○ : Continuity ○=○ : Airflow

Step	Terminal		Port		
	A	B	A	B	C
1	○—○	○—○	○—○	○=○	○=○
2	B+	GND	○=○	○=○	

X3U113WDF

### Circuit Open/Short Inspection

1. Disconnect the PCM connector. (See 01-40B-7 PCM REMOVAL/INSTALLATION [FS].)
2. Connect the **SST** (104 Pin Breakout Box) to the PCM as shown.
3. Tighten the connector attaching screw.

#### Tightening torque

7.9—10.7 N·m {80—110 kgf·cm, 69.5—95.4 in·lbf}

4. Inspect for an open or short circuit in the following wiring harnesses by probing the applicable sensor and **SST** (104 Pin Breakout Box) terminals with ohmmeter leads.

#### Open circuit

- Power circuit (VICS solenoid valve connector terminal A and main relay connector terminal D)
- Control circuit (VICS solenoid valve connector terminal B and PCM connector terminal 19)

#### Short circuit

- Power circuit (VICS solenoid valve connector terminal A and main relay connector terminal D to GND)
- Control circuit (VICS solenoid valve connector terminal B and PCM connector terminal 19 to GND)

5. Reconnect the VICS solenoid valve connector.
6. Reconnect the battery negative cable.

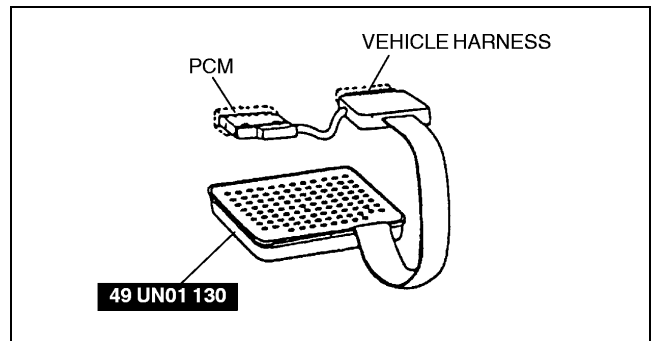

X3U113WDG

# INTAKE-AIR SYSTEM [FS]

## VARIABLE TUMBLE CONTROL SYSTEM (VTCS) DIAGRAM [FS]

A3U011313012W01

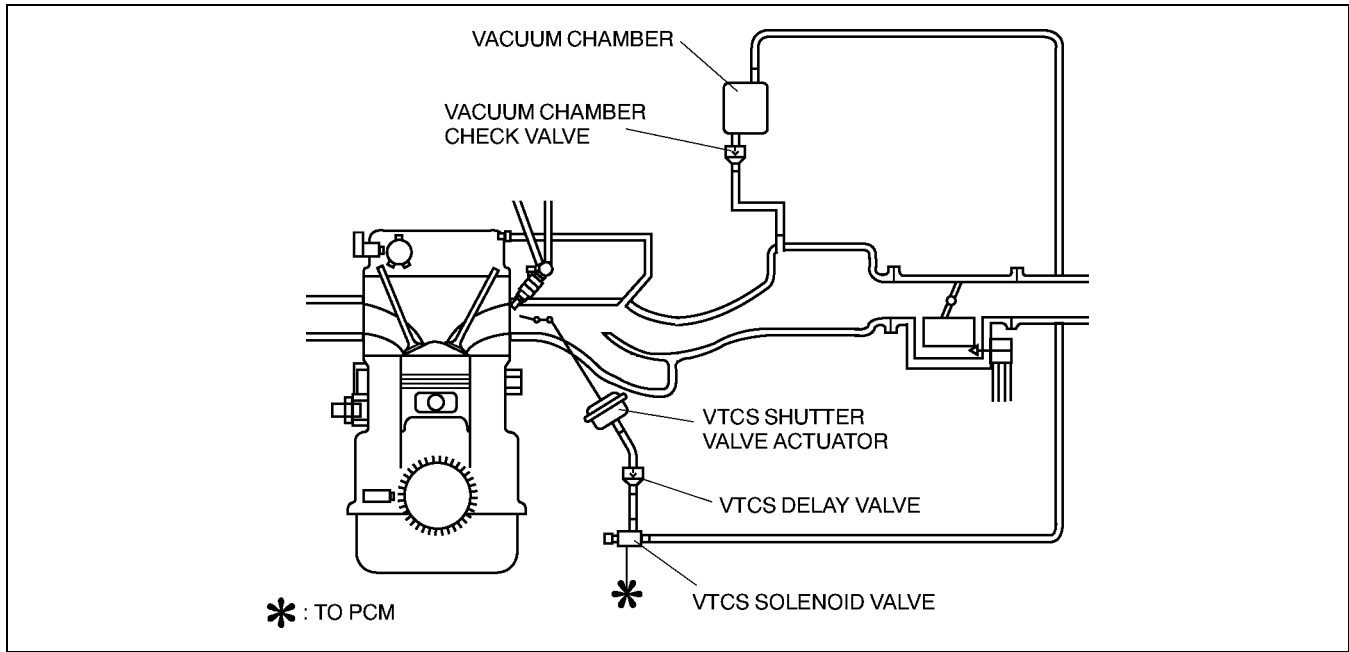

01-13B

Z3U0113W012

## VARIABLE TUMBLE CONTROL SYSTEM (VTCS) SHUTTER VALVE ACTUATOR REMOVAL/INSTALLATION [FS]

A3U011320153W01

1. Disconnect the battery negative cable.
2. Remove the air hose, throttle body and intake manifold. (See 01-13B-6 INTAKE-AIR SYSTEM REMOVAL/INSTALLATION [FS].)
3. Remove in the order indicated in the table.

1	E-ring
2	Bolts
3	VTCS shutter valve actuator

4. Install in the reverse order of removal.

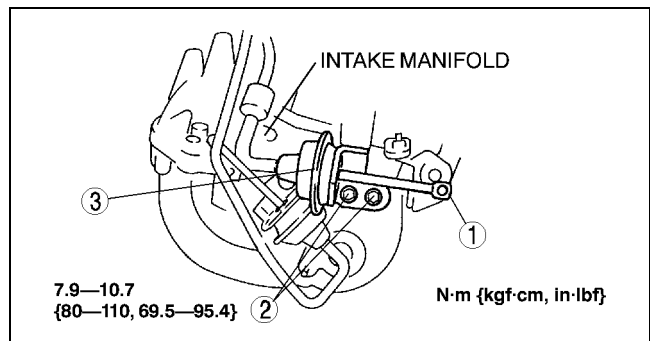

Z3U0113W013

# INTAKE-AIR SYSTEM [FS]

## VARIABLE TUMBLE CONTROL SYSTEM (VTCS) SHUTTER VALVE ACTUATOR INSPECTION [FS]

A3U011320153W02

### Operating Inspection

#### Note

- Perform the following test only as directed.

1. Carry out the "VTCS Operation Inspection". (See 01-03B-57 Variable Tumble Control System (VTCS) Inspection.)
  - If not as specified, perform the further inspection for the VTCS shutter valve actuator inspection.
2. Disconnect the vacuum hose from the VTCS shutter valve actuator.
3. Connect a vacuum pump to the VTCS shutter valve actuator.
4. Apply pressure slowly and inspect the rod movement of the VTCS shutter valve actuator under the following condition.
  - If not as specified, replace the VTCS shutter valve actuator. (See 01-13B-13 VARIABLE TUMBLE CONTROL SYSTEM (VTCS) SHUTTER VALVE ACTUATOR REMOVAL/INSTALLATION [FS].)
  - If as specified, but "VTCS Operation Inspection" is failed, inspect the vacuum hoses for improper routing, kinks or leakage.

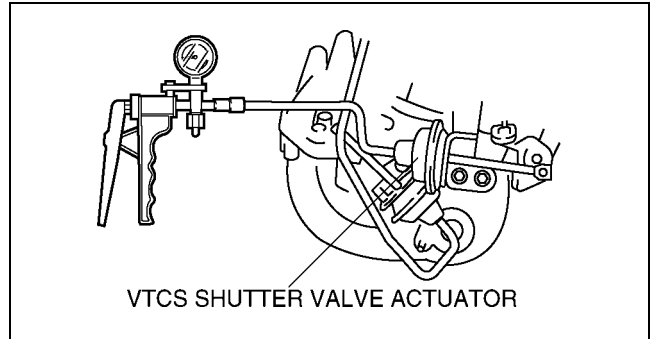

Z3U0113W014

Pressure (kPa {mmHg, inHg})	Rod movement
Above -2.7 {-2.0, -0.80}	Not pulled
-8.0— -35.3 {-61— -264, -2.4— -10.4}	Starts to move
Below -35.3 {-26.5, -10.4}	Fully pulled

5. Disconnect the vacuum pump from the VTCS shutter valve actuator.
6. Reconnect the vacuum hose to the VTCS shutter valve actuator.

## VARIABLE TUMBLE CONTROL SYSTEM (VTCS) DELAY VALVE REMOVAL/INSTALLATION [FS]

A3U011318800W01

1. Disconnect the battery negative cable.
2. Remove in the order indicated in the table.

1	Vacuum hose
2	VTCS delay valve

3. Install in the reverse order of removal.

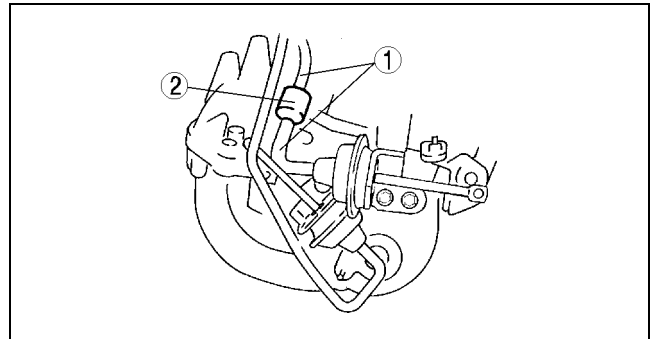

Z3U0113W016



# INTAKE-AIR SYSTEM [FS]

## VARIABLE TUMBLE CONTROL SYSTEM (VTCS) DELAY VALVE INSPECTION [FS]

A3U011318800W02

1. Remove the VTCS delay valve. (See 01–13B–14 VARIABLE TUMBLE CONTROL SYSTEM (VTCS) DELAY VALVE REMOVAL/INSTALLATION [FS].)
2. Blow through port A and verify that the air flows from port B.
  - If not as specified, replace the VTCS delay valve.
3. Blow through port B and verify that the air does not flow from port A.
  - If not as specified, replace the VTCS delay valve.

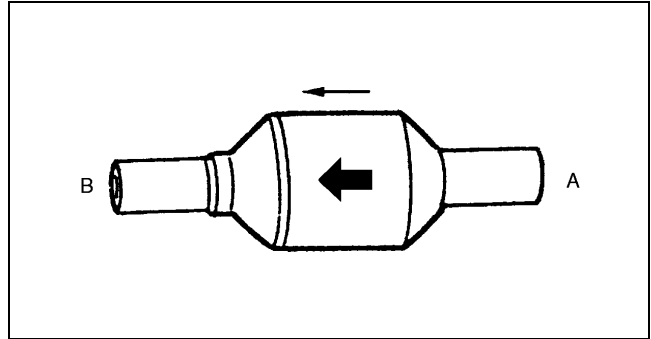

X3U113WAA

01–13B

## VARIABLE TUMBLE CONTROL SYSTEM (VTCS) SOLENOID VALVE INSPECTION [FS]

A3U011318745W01

### Simulation Test

1. Carry out the “VTCS Operation Inspection”. (See 01–03B–57 Variable Tumble Control System (VTCS) Inspection.)
  - If not as specified, perform the further inspection for the VTCS solenoid valve.

### Airflow Inspection

#### Note

- Perform the following test only as directed.

1. Remove the VTCS solenoid valve.
2. Inspect for airflow each port under the following condition.
  - If as specified, replace the VTCS solenoid valve.
  - If as specified but the “VTCS Operation Inspection” is failed, inspect evaporative hoses for improper routing, kinks or leakage, and inspect “Circuit Open/Short Inspection”.
    - If there is an open or short circuit, repair or replace wiring harnesses.
    - If the above open or short circuit is okay, replace VTCS solenoid valve.

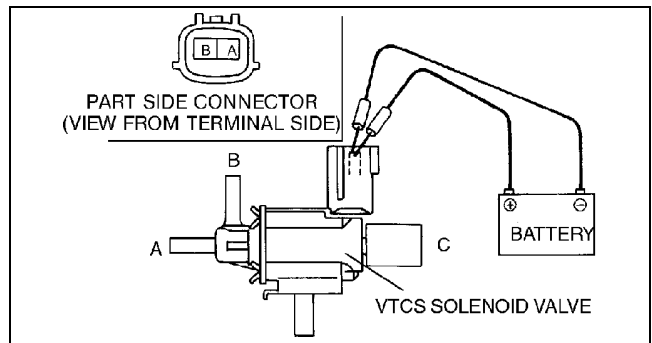

Y3U113WA4

○—○ : Continuity ○=○ : Airflow

Step	Terminal		Port		
	A	B	A	B	C
1	○—○	○—○		○=○	○=○
2	B+	GND	○—○	○=○	

X3U113WAI

## INTAKE-AIR SYSTEM [FS]

### Circuit Open/Short Inspection

1. Disconnect the PCM connector.
2. Connect the **SST** (104 Pin Breakout Box) to the PCM as shown.
3. Tighten the connector attaching screw.

#### Tightening torque

**7.9—10.7 N·m {80—110 kgf·cm, 69.5—95.4 in·lbf}**

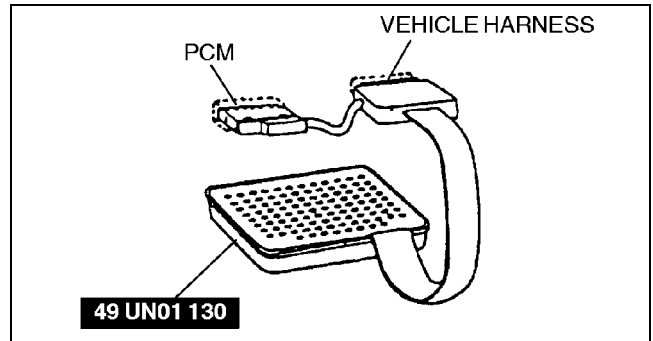

X3U113WAC

4. Inspect for an open or short circuit in the following wiring harnesses by probing the applicable sensor and **SST** (104 Pin Breakout Box) terminals with ohmmeter leads.

#### Open circuit

- Power circuit (VTCS solenoid valve connector terminal A and main relay connector terminal D)
- Control circuit (VTCS solenoid valve connector terminal B and PCM connector terminal 19)

#### Short circuit

- Power circuit (VTCS solenoid valve connector terminal A and main relay connector terminal D to GND)
- Control circuit (VTCS solenoid valve connector terminal B and PCM connector terminal 19 to GND)

5. Reconnect the VTCS solenoid valve connector.
6. Reconnect the battery negative cable.

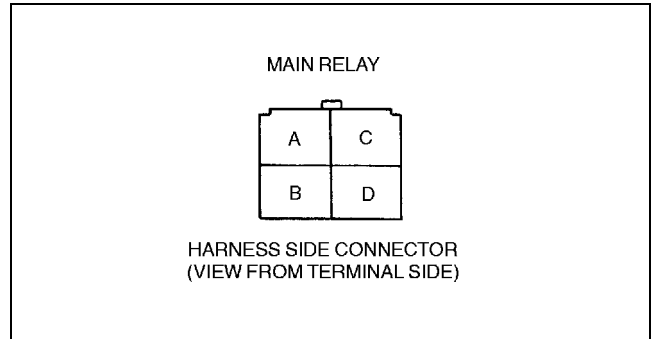

Z3U0113W998

## ACCELERATOR CABLE REMOVAL/INSTALLATION [FS]

A3U011341660W01

#### Note

- Accelerator removal and installation on cruise control system-equipped vehicles is not possible.

1. Remove in the order indicated in the table.

1	Retainer
2	E ring
3	Accelerator pedal (See 01-13B-17 Accelerator Pedal Installation Note)
4	Return spring

2. Install in the reverse order of removal.

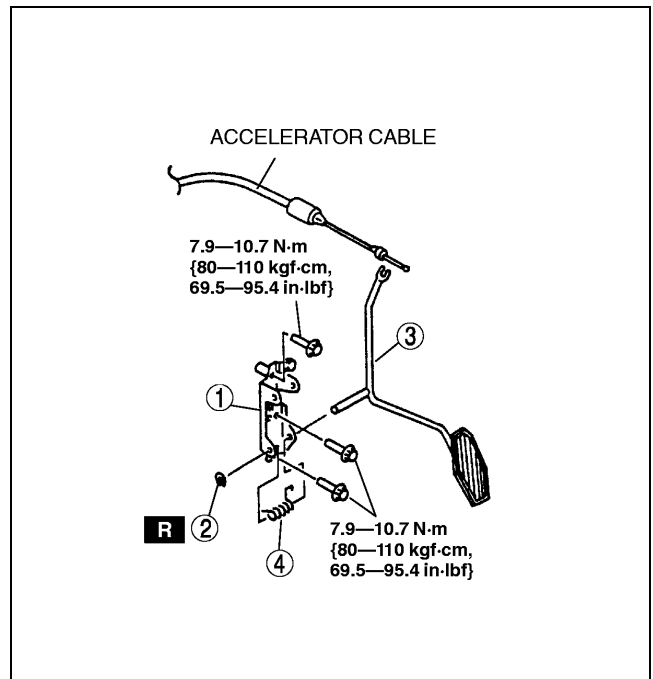

X3U113WDC

## INTAKE-AIR SYSTEM [FS]

### Accelerator Pedal Installation Note

1. Set the accelerator pedal securely, be sure not to bend the accelerator cable.

### ACCELERATOR CABLE INSPECTION [FS]

A3U011341660W02

1. Verify that the throttle valve is fully closed.

#### Note

- To measure cable free play, push the cable into the housing and put a white mark on the cable at the end of the housing, then pull it out and measure distance from the white mark to the end of the cable housing.
2. Measure the free play of accelerator cable.
    - If not as specified, adjust the accelerator cable. (See 01-13B-17 ACCELERATOR CABLE ADJUSTMENT [FS].)

#### Free Play

1—3 mm {0.04—0.11 in}

### ACCELERATOR CABLE ADJUSTMENT [FS]

A3U011341660W03

1. Move the white locking tab A to the unlock position.
2. Turn stopper B to the unlock position.

#### Note

- If the stopper B will not be unlocked, it may be necessary to carefully bend the tab C out using a suitable tool.
3. To adjust the free play, push or pull the accelerator cable housing directly behind the spring.
  4. Turn the stopper B to the lock position.

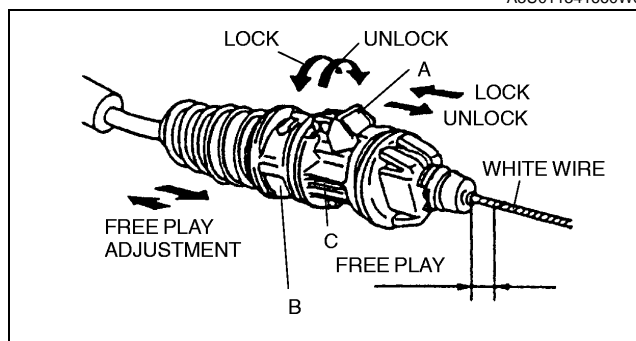

X3U113WDD

#### Free Play

1—3 mm {0.04—0.11 in}

5. Measure the throttle cable free play, making sure that it is within the specification.
6. Move the white locking tab A to the lock position.
7. Verify correct accelerator operation.

## **01-14 FUEL SYSTEM**

<b>FUEL SYSTEM LOCATION INDEX</b> . . . .	<b>01-14-2</b>
Engine Room Side . . . . .	01-14-2
<b>FUEL SYSTEM DIAGRAM</b> . . . . .	<b>01-14-4</b>
<b>BEFORE REPAIR PROCEDURE</b> . . . . .	<b>01-14-4</b>
Fuel Line Safety Procedure . . . . .	01-14-4
<b>AFTER REPAIR PROCEDURE</b> . . . . .	<b>01-14-5</b>
Fuel Leakage Inspection . . . . .	01-14-5
<b>FUEL PRESSURE INSPECTION</b> . . . . .	<b>01-14-6</b>
<b>FUEL TANK</b>	
<b>REMOVAL/INSTALLATION</b> . . . . .	<b>01-14-9</b>
Plastic Fuel Hose Removal Note . . . . .	01-14-11
Nonreturn Valve Installation Note . . . . .	01-14-11
Joint Hose Installation Note . . . . .	01-14-12
Evaporative Hose Installation Note . . . . .	01-14-12
Plastic Fuel Hose Installation Note . . . . .	01-14-12
<b>FUEL TANK INSPECTION</b> . . . . .	<b>01-14-13</b>
<b>FUEL SHUT-OFF VALVE</b>	
<b>INSPECTION</b> . . . . .	<b>01-14-14</b>
<b>NONRETURN VALVE INSPECTION</b> . . . . .	<b>01-14-14</b>
<b>FUEL PUMP UNIT</b>	
<b>REMOVAL/INSTALLATION</b> . . . . .	<b>01-14-14</b>
<b>FUEL PUMP UNIT</b>	
<b>DISASSEMBLY/ASSEMBLY</b> . . . . .	<b>01-14-15</b>
<b>FUEL PUMP UNIT INSPECTION</b> . . . . .	<b>01-14-15</b>
Continuity Inspection . . . . .	01-14-15
Circuit Open/Short Inspection . . . . .	01-14-16
Fuel Pump Maximum Pressure	
Inspection . . . . .	01-14-17
Fuel Pump Hold Pressure	
Inspection . . . . .	01-14-19

<b>FUEL FILTER (HIGH-PRESSURE)</b>	
<b>REMOVAL/INSTALLATION</b> . . . . .	<b>01-14-21</b>
<b>FUEL INJECTOR</b>	
<b>REMOVAL/INSTALLATION</b> . . . . .	<b>01-14-21</b>
Plastic Fuel Hose Removal Note . . . . .	01-14-23
Fuel Injector Installation Note	
(FS only) . . . . .	01-14-23
<b>FUEL INJECTOR INSPECTION</b> . . . . .	<b>01-14-24</b>
Simulation Test . . . . .	01-14-24
Resistance Inspection . . . . .	01-14-24
Circuit Open/Short Inspection . . . . .	01-14-24
Fuel Leakage Test . . . . .	01-14-25
Volume Test . . . . .	01-14-26
Using the SST . . . . .	01-14-26
Using a Fuel Injector Tester . . . . .	01-14-27
<b>PRESSURE REGULATOR</b>	
<b>REMOVAL/INSTALLATION</b> . . . . .	<b>01-14-27</b>
<b>PRESSURE REGULATOR</b>	
<b>INSPECTION</b> . . . . .	<b>01-14-28</b>
Simulation Test . . . . .	01-14-28
Operation Inspection . . . . .	01-14-28
<b>PULSATION DAMPER</b>	
<b>REMOVAL/INSTALLATION</b> . . . . .	<b>01-14-30</b>
<b>PULSATION DAMPER INSPECTION</b> . . . . .	<b>01-14-31</b>
<b>PRC SOLENOID VALVE</b>	
<b>REMOVAL/INSTALLATION</b> . . . . .	<b>01-14-31</b>
<b>PRC SOLENOID VALVE INSPECTION</b> . . . . .	<b>01-14-31</b>
Airflow Inspection . . . . .	01-14-31
Circuit Open/Short Inspection . . . . .	01-14-32

# FUEL SYSTEM

## FUEL SYSTEM LOCATION INDEX

A3U011401006W01

### Engine Room Side

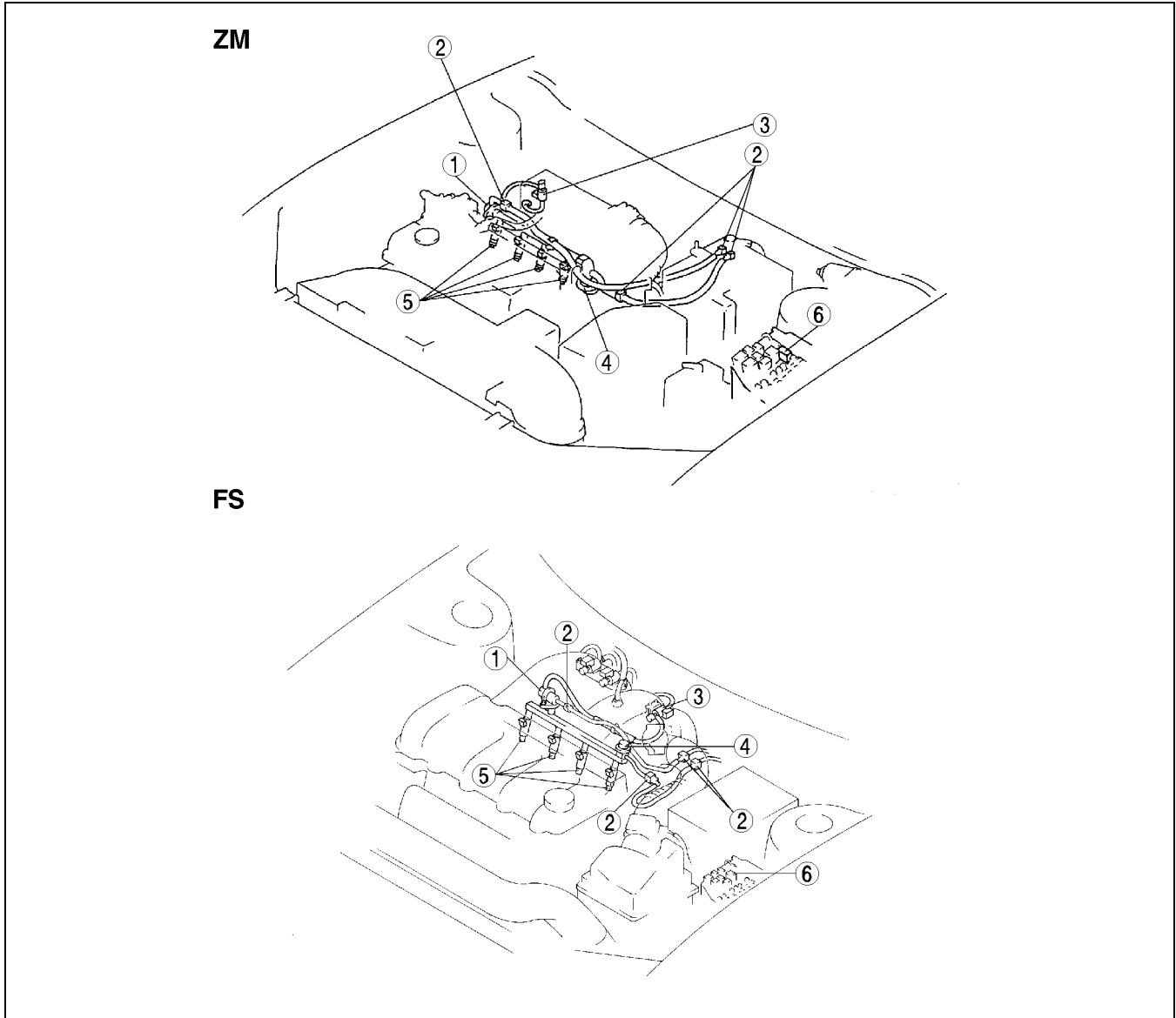

Z3U0114W985

1	Pressure regulator (See 01-14-27 PRESSURE REGULATOR REMOVAL/INSTALLATION) (See 01-14-28 PRESSURE REGULATOR INSPECTION)
2	Quick release connector (See 01-14-22 Plastic Fuel Hose Removal Note) (See 01-14-23 Plastic Fuel Hose Installation Note)
3	PRC solenoid valve (See 01-14-31 PRC SOLENOID VALVE REMOVAL/INSTALLATION) (See 01-14-31 PRC SOLENOID VALVE INSPECTION)

4	Pulsation damper (See 01-14-30 PULSATION DAMPER REMOVAL/INSTALLATION) (See 01-14-31 PULSATION DAMPER INSPECTION)
5	Fuel injector (See 01-14-21 FUEL INJECTOR REMOVAL/INSTALLATION) (See 01-14-24 FUEL INJECTOR INSPECTION)
6	Fuel pump relay (See 09-21-5 RELAY INSPECTION)

# FUEL SYSTEM

01-14

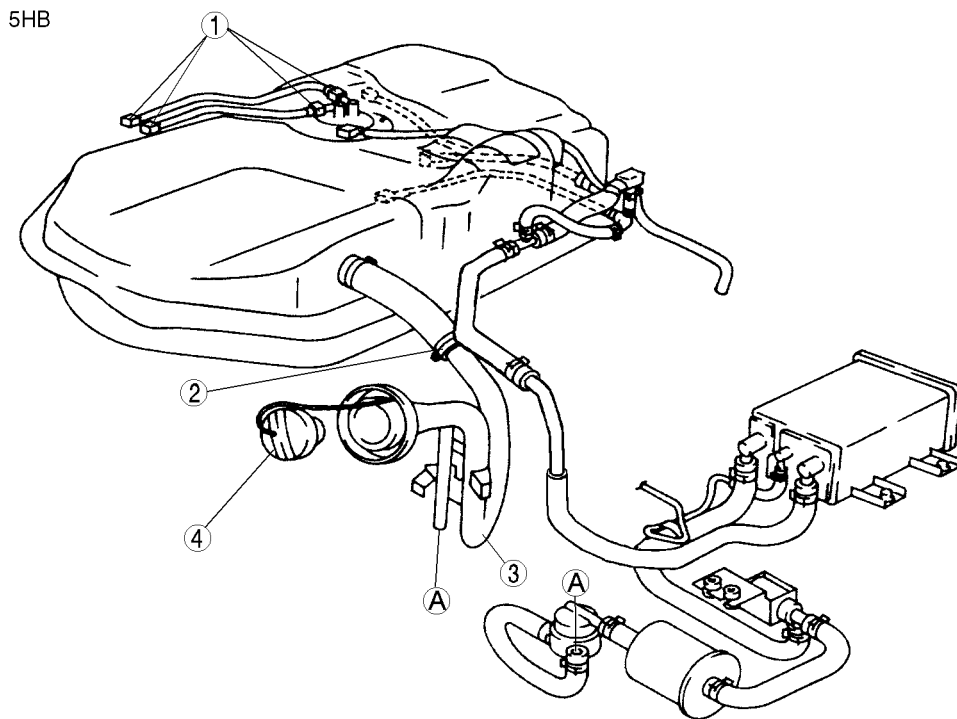
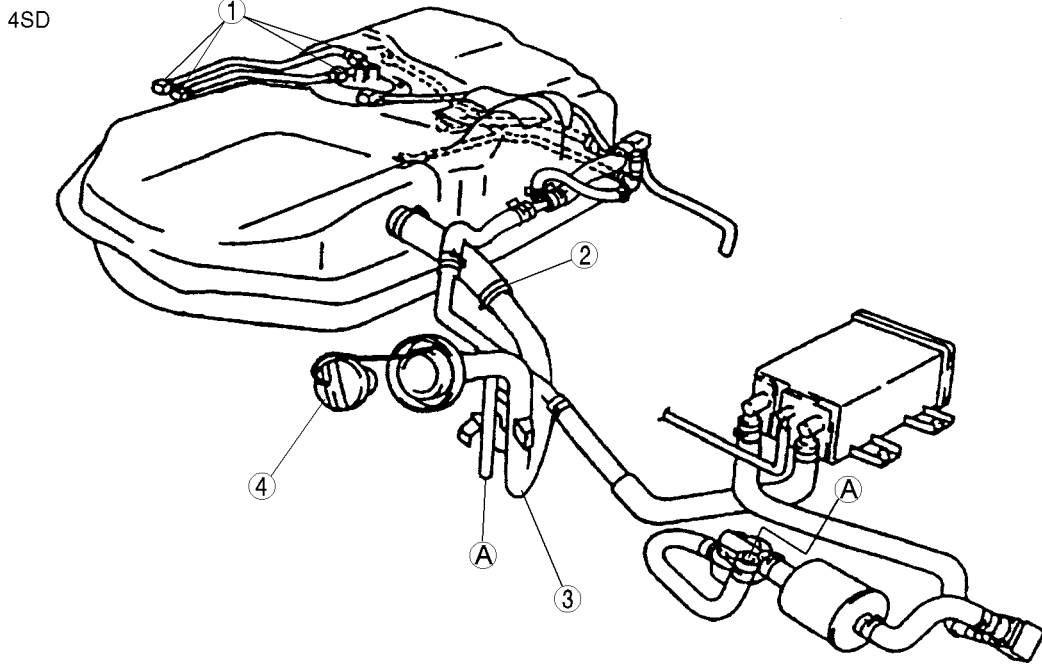

A3U0114W003

1	Quick release connector (See 01-14-22 Plastic Fuel Hose Removal Note) (See 01-14-23 Plastic Fuel Hose Installation Note)
2	Nonreturn valve (See 01-14-11 Nonreturn Valve Installation Note)

3	Fuel-filler pipe
4	Fuel-filler cap (See 01-16-13 FUEL-FILLER CAP INSPECTION)

# FUEL SYSTEM

## FUEL SYSTEM DIAGRAM

A3U011401006W02

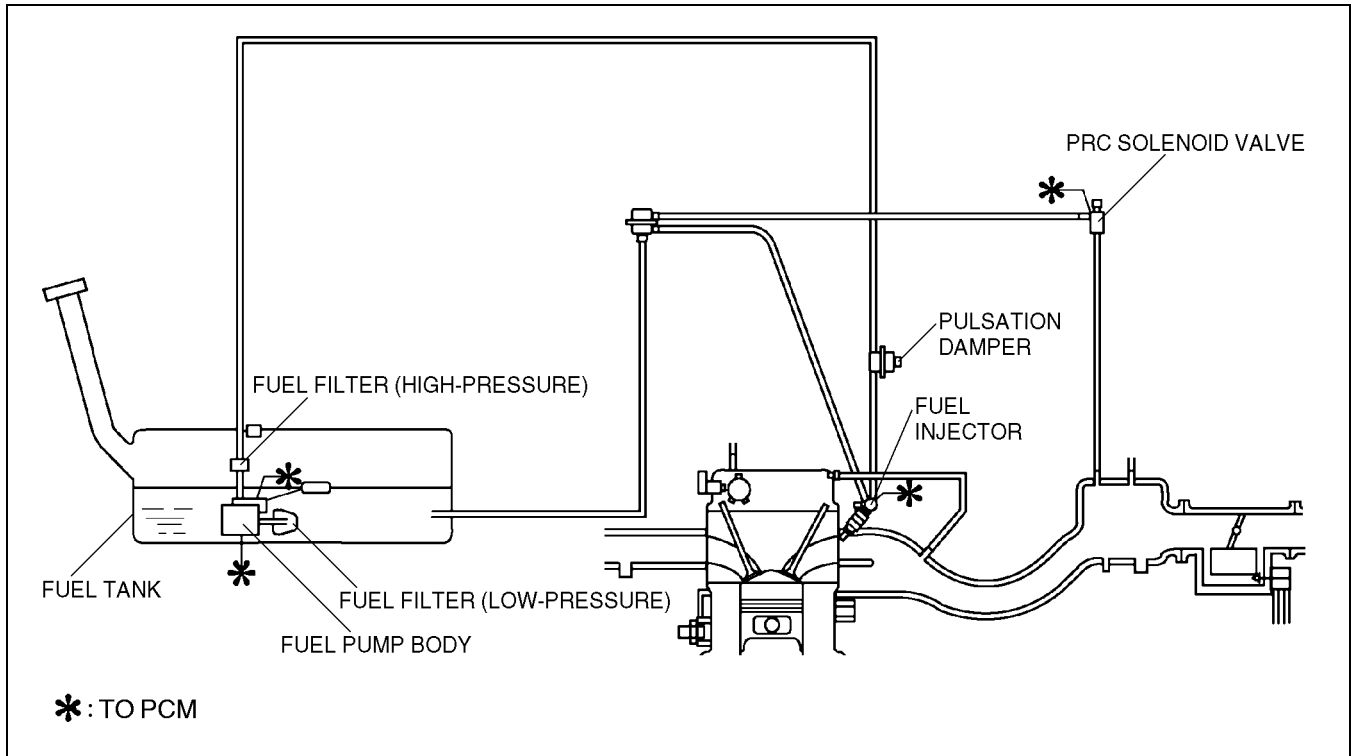

Z3U0114W997

## BEFORE REPAIR PROCEDURE

A3U011401006W03

### Warning

- Fuel vapor is hazardous. It can easily ignite, causing serious injury and damage. Always keep sparks and flames away from fuel.
- Fuel line spills and leakage are dangerous. Fuel can ignite and cause serious injuries or death and damage. Fuel can also irritate skin and eyes. To prevent this, always complete the following "Fuel Line Safety Procedure".

### Fuel Line Safety Procedure

#### Note

- Fuel in the fuel system is under high pressure even when the engine is not running.

1. Remove the fuel-filler cap and release the pressure in the fuel tank.
2. Remove the fuel pump relay.
3. Start the engine.
4. After the engine stalls, crank the engine several times.
5. Turn the ignition switch off.
6. Install the fuel pump relay.

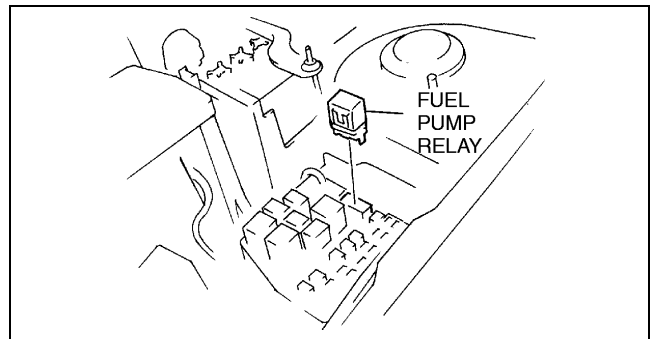

X3U114WA0

# FUEL SYSTEM

## AFTER REPAIR PROCEDURE

A3U011401006W04

### Warning

- Fuel line spills and leakage are dangerous. Fuel can ignite and cause serious injuries or death and damage. When installing the fuel hose, observe "Fuel Leakage Inspection" described below.

### Fuel Leakage Inspection

#### Warning

- Fuel line spills and leakage are dangerous. Fuel can ignite and cause serious injuries or death and damage. Always carry out the following procedure with the engine stopped.

#### Caution

- Connecting the wrong DLC terminal may possibly cause a malfunction. Carefully connect the specified terminal only.

1. Short the DLC terminal F/P to the body GND using a jumper wire.
2. Turn the ignition switch to ON to operate the fuel pump.
3. Pressurize the system this way for **at least 5 min** to be sure of no leakage.
  - If there is fuel leakage, inspect the fuel hoses, hose clamps, and fuel pipe sealing surface and replace if necessary.
4. After repairing, assemble the system and repeat Steps 1 to 3.

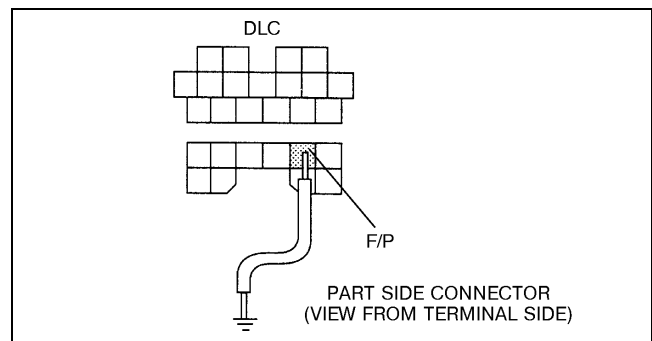

X3U114WA1

01-14



# FUEL SYSTEM

## FUEL PRESSURE INSPECTION

A3U011401006W05

### Warning

- Fuel line spills and leaks are dangerous. Fuel can ignite and cause serious injuries or death. Fuel can also irritate skin and eyes. To prevent this, always complete the “BEFORE REPAIR PROCEDURE”. (See 01–14–4 BEFORE REPAIR PROCEDURE.)

### Caution

- Disconnecting/connecting the quick release connector without cleaning it may possibly cause damage to the fuel pipe and quick release connector. Always clean the quick release connector joint area before disconnecting/connecting, and make sure that it is free of foreign materials.

1. Disconnect the battery negative cable.
2. Disconnect the quick release connector from the pulsation damper as follows:
  - (1) Push apart the lock clip and unlock it.

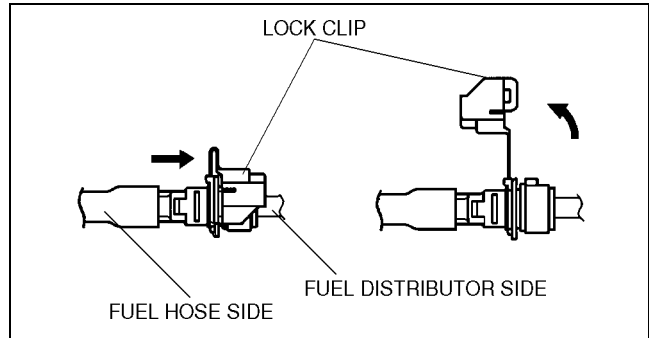

Y3E3912W201

- (2) Lift the tab on the blue locking coupler until the fuel line can be released.
- (3) Pull the fuel hose straight back.

### Note

- The blue stopper may be removed from the quick connector. Be sure not to lose it. Reinstall it to the quick release connector before reconnecting the fuel line.

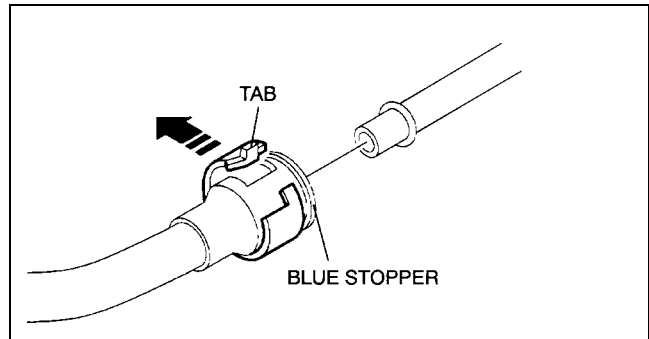

Z3U0114W986

- The orange locking coupler has two internal locking tabs which restrain the pulsation damper pipe. Be sure that the tab on the locking coupler is rotated until it stops to release two internal locking tabs.

3. Push the **SST** quick release connector into the fuel distributor and fuel main hose into the **SST** until a click is heard.

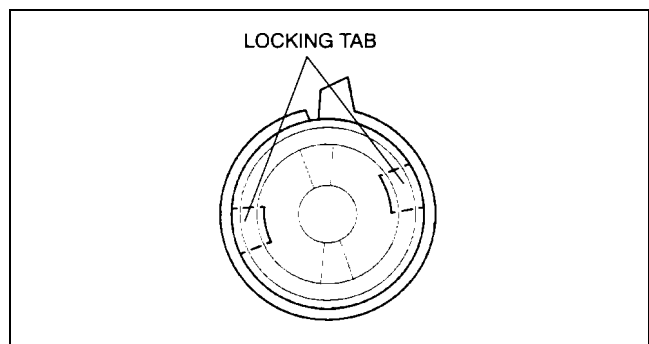

Z3U0114W993

## FUEL SYSTEM

- Turn the lever on the **SST** as shown.

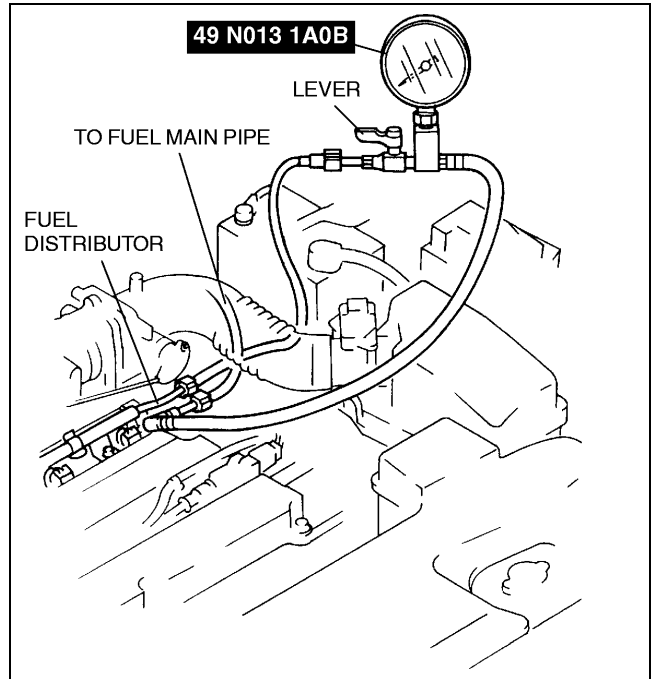

Y3U114WB2

- Connect the battery negative cable.

### Caution

- Connecting to the wrong DLC terminal may possibly cause a malfunction. Carefully connect to the specified terminal only.

- Short the DLC terminal F/P to the body GND using a jumper wire.
- Turn the ignition switch to ON and measure the fuel line pressure.
  - If the pressure is higher than specified, inspect the fuel pump maximum pressure. If specified, inspect fuel return hose or the pressure regulator is clogged.
  - If the pressure is lower than specified, proceed to Step (1).

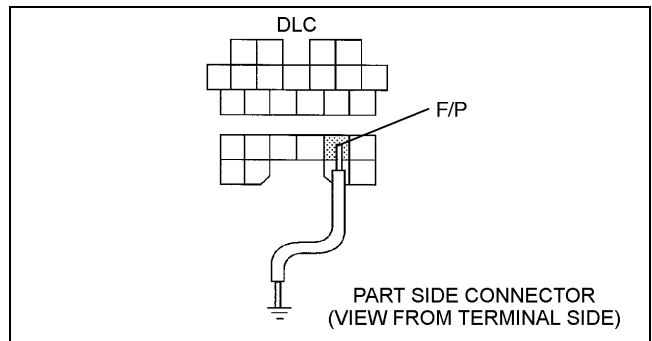

Y3U114WA1

### Fuel line pressure

270—310 kPa {2.7—3.2 kgf/cm<sup>2</sup>, 39—45 psi}

- Inspect change in the fuel line pressure while turning the lever as shown.
  - If the fuel line pressure quickly increases, inspect the pressure regulator.
  - If fuel line pressure gradually increases, inspect the fuel pump maximum pressure.
  - If the fuel pump maximum pressure is normal, inspect for clogging between the fuel pump and the pressure regulator.

## FUEL SYSTEM

8. Turn off the ignition switch and disconnect the jumper wire
9. Observe the fuel pressure **after 5 min.**
  - If the fuel hold pressure is lower than specified, proceed to step (1).

### Fuel hold pressure

**More than 150 kPa {1.5 kgf/cm<sup>2</sup>, 22 psi}**

- (1) Inspect changes in the fuel line pressure while turning the lever as shown.
  - If the fuel line pressure holds, replace the pressure regulator. (See 01-14-21 FUEL INJECTOR REMOVAL/INSTALLATION.)
  - If the fuel line pressure does not hold, inspect the fuel leaks from the fuel line and the fuel injector.

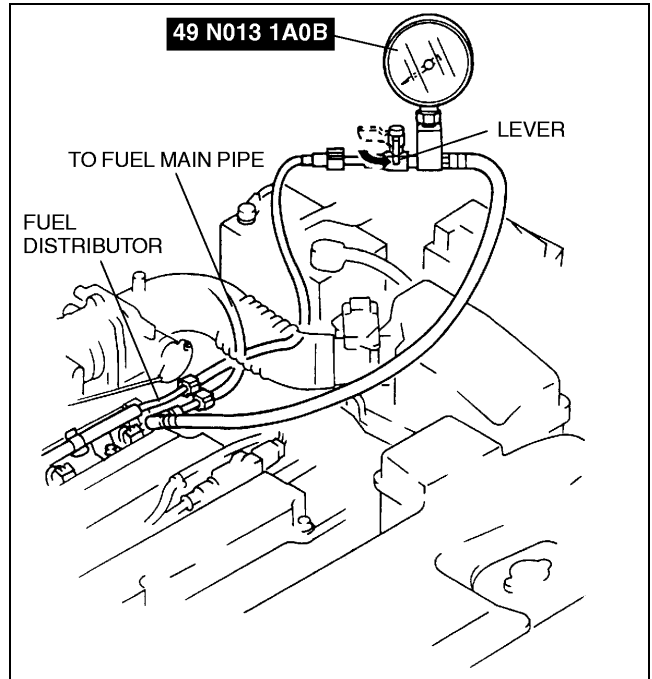

Y3U114WB3

10. Disconnect the **SST**.

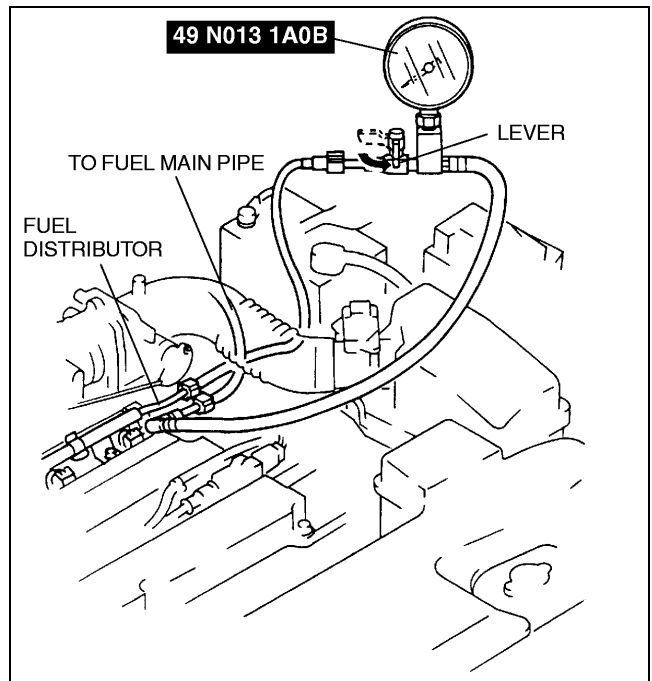

Y3U114WB3

## FUEL SYSTEM

### Note

- A checker tab is integrated with the quick release connector for new plastic fuel hoses. The checker tab will be released from the quick release connector after it is completely engaged with the fuel pipe.

11. Inspect the plastic fuel hose and fuel pipe sealing surface for damage and deformation, and replace if necessary.
  - If the quick release connector O-ring is damaged or has slipped, replace the plastic fuel hose.
12. Reconnect the fuel main hose to the fuel distributor until a click is heard.
13. Pull the quick release connector by hand and verify that it is installed securely.
14. Attach the lock clip to the quick release connector in the direction of the fuel distributor and lock it, as shown in the figure.

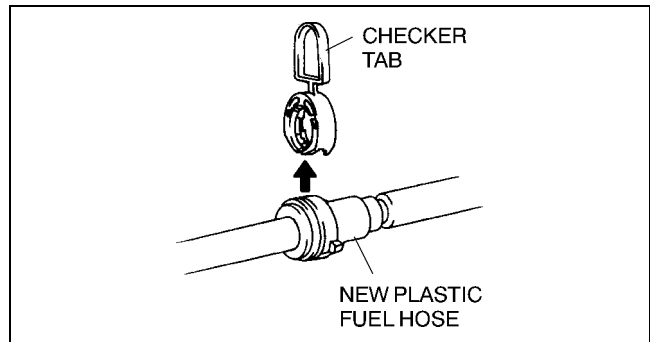

YMU114WA8

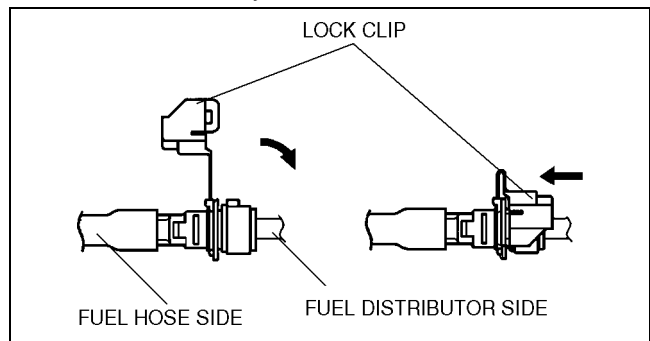

Y3E3912W202

## FUEL TANK REMOVAL/INSTALLATION

A3U011442110W01

### Warning

- **Repairing a fuel tank that has not been properly steam cleaned can be dangerous. Explosion or fire may cause death or serious injury. Always properly steam clean a fuel tank before repairing it.**
- **Fuel line spills and leakage are dangerous. Fuel can ignite and cause serious injuries or death and damage. Fuel can also irritate skin and eyes. To prevent this, do not damage the sealing surface of the fuel pump unit when removing or installing.**

### Caution

- **Disconnecting/connecting the quick release connector without cleaning it may possibly cause damage to the fuel pipe and quick release connector. Always clean the quick release connector joint area before disconnecting/connecting, and make sure that it is free of foreign material.**

1. Level the vehicle.
2. Complete the "BEFORE REPAIR PROCEDURE". (See 01-14-4 BEFORE REPAIR PROCEDURE.)
3. Disconnect the negative battery cable.
4. Remove the rear seat cushion. (See 09-13-5 REAR SEAT REMOVAL/INSTALLATION.)
5. Remove the service hole cover.
6. Remove the fuel pump unit.
7. Siphon the fuel from the fuel tank.
8. Remove the presilencer. (See 01-15-1 EXHAUST SYSTEM REMOVAL/INSTALLATION.)
9. Remove in the order indicated in the table.
10. Install in the reverse order of removal.

# FUEL SYSTEM

11. Complete the "AFTER REPAIR PROCEDURE". (See 01-14-5 AFTER REPAIR PROCEDURE.)

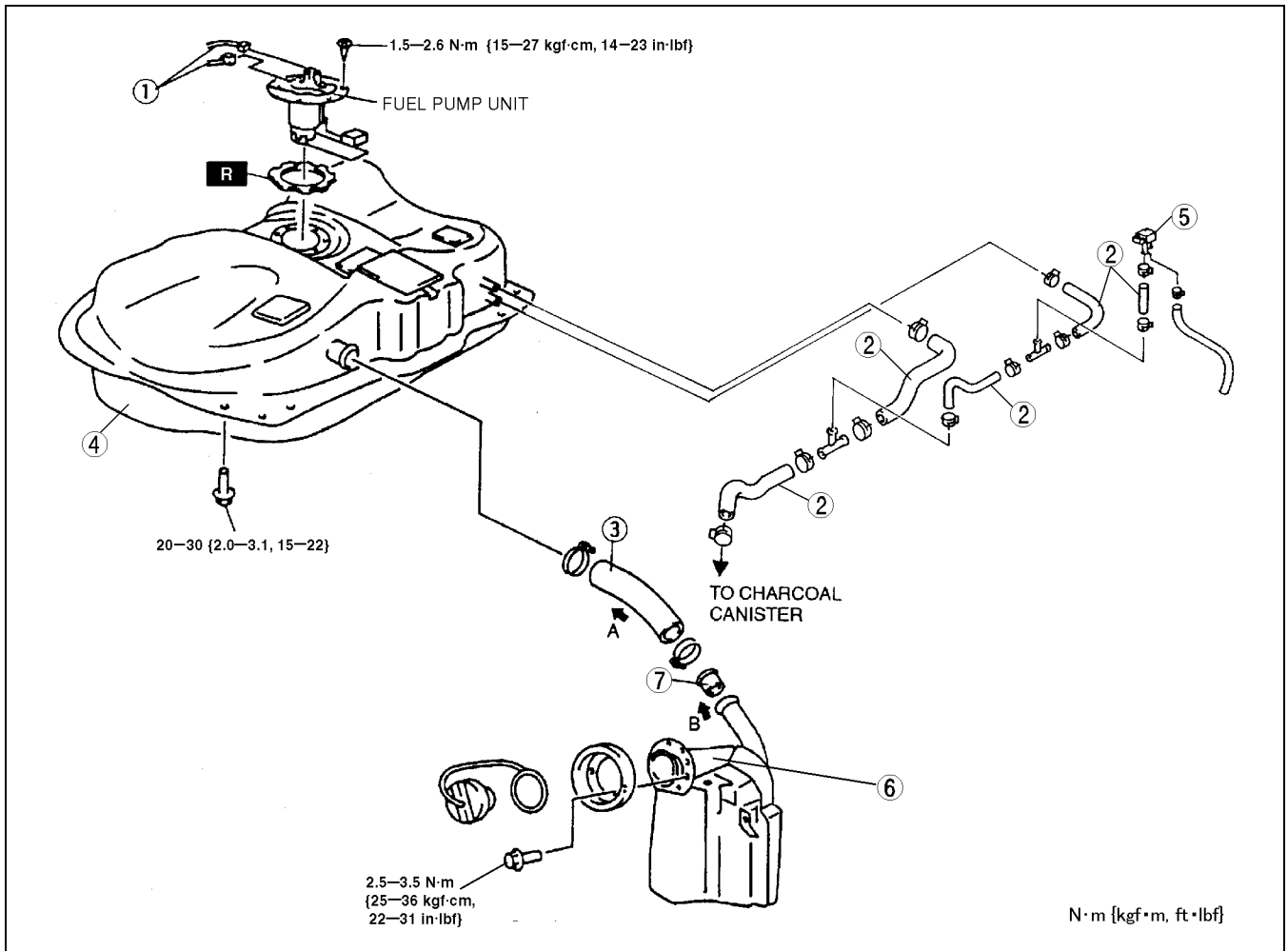

A3U0114W002

1	Plastic fuel hose (See 01-14-11 Plastic Fuel Hose Removal Note.) (See 01-14-12 Plastic Fuel Hose Installation Note.)
2	Evaporative hose (See 01-14-12 Evaporative Hose Installation Note.)
3	Joint hose (See 01-14-12 Joint Hose Installation Note.)

4	Fuel tank
5	Fuel tank pressure sensor
6	Fuel-filler pipe
7	Nonreturn valve (See 01-14-11 Nonreturn Valve Installation Note.)

# FUEL SYSTEM

## Plastic Fuel Hose Removal Note

### Caution

- The retainer must be replaced if removed from the fuel pipe without using the SST. Otherwise, effectiveness of the retainer will be reduced.

1. Inspect that the quick release connector joint area is free of foreign material.
2. Clean as necessary.
3. Set the **SST** as shown and push into the quick release connector to disconnect the plastic fuel hose.

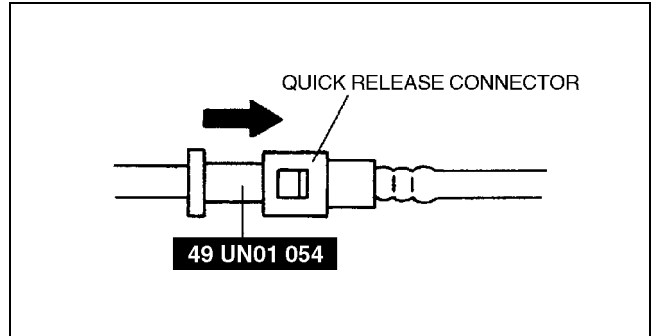

4. Cover the disconnected quick release connector and fuel pipe to prevent them from being scratched or contaminated with foreign material.

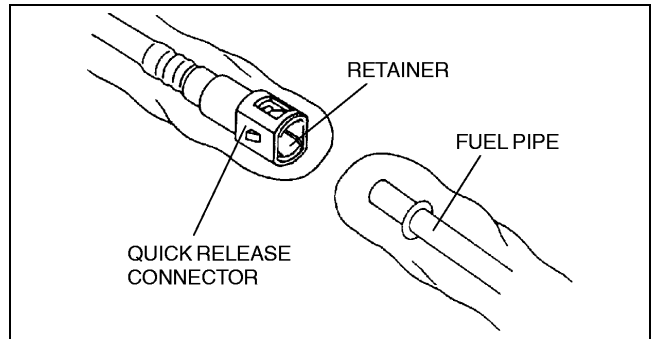

## Nonreturn Valve Installation Note

1. Align the nonreturn valve with the notch in the fuel-filler pipe as shown, then install.

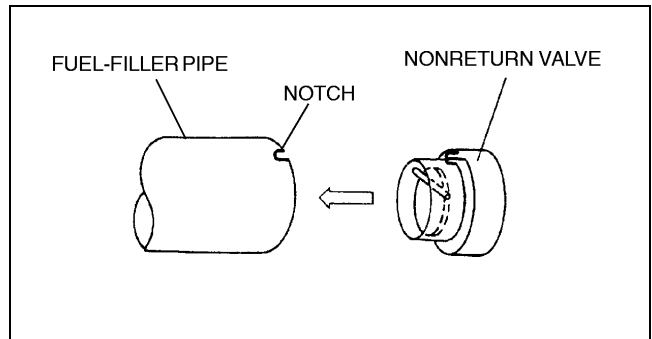

# FUEL SYSTEM

## Joint Hose Installation Note

1. Fit the joint hose onto the respective fittings within the specification, and install clamps as shown.

### Specification

35—40 mm {1.4—1.5 in}

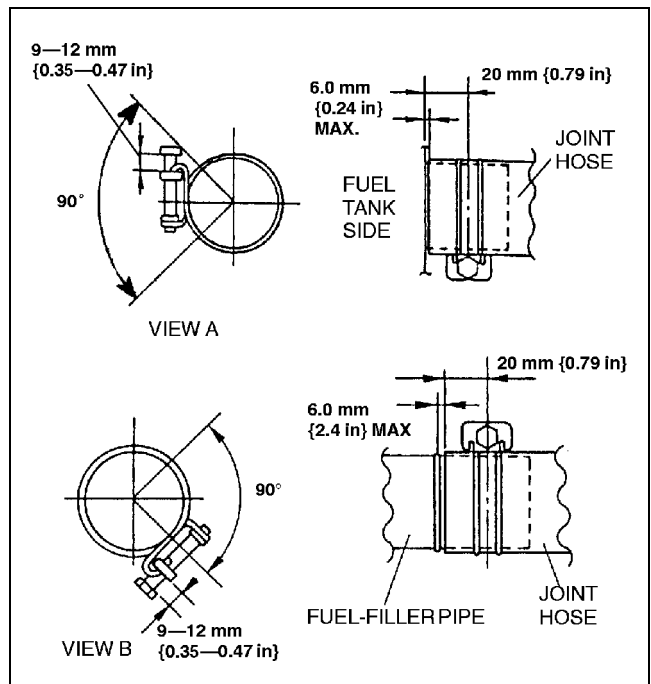

A3U0114W001

## Evaporative Hose Installation Note

1. Fit evaporative hose onto the respective fittings within the specification, and install clamps as shown.

### Specification

10 mm {0.39 in}

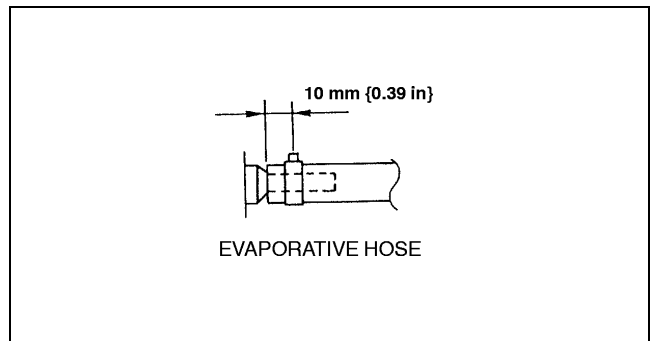

X3U114WA5

## Plastic Fuel Hose Installation Note

### Note

- A checker tab is integrated with quick release connector for new plastic fuel hoses. The checker tab will be released from the quick release connector after it is completely engaged with the fuel pipe.

1. When the retainer is not removed, perform the following procedure.
  - (1) Inspect the fuel pump unit sealing surface for damage and deformation, and replace if necessary.
    - If the quick release connector O-ring is damaged, replace the plastic fuel hose.
  - (2) Apply a small amount of clean engine oil to the sealing surface of the fuel pump unit.

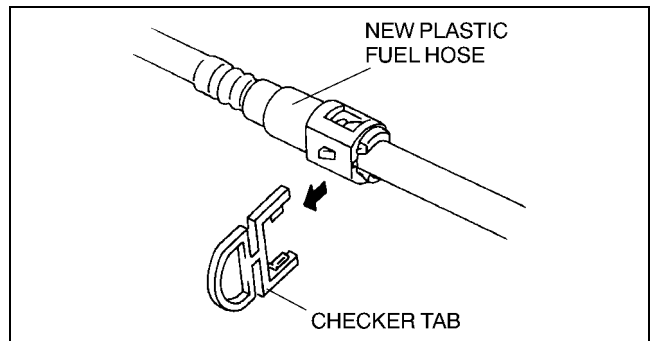

YMU114WF0

## FUEL SYSTEM

- (3) Align the fuel pipe on the fuel pump unit and quick release connector so that the tabs of the retainer are correctly fitted into the quick release connector. Push the quick release connector straight into the retainer until a click is heard.
- (4) Lightly pull and push the quick release connector a few times by hand and verify that it can move **2.0—3.0 mm {0.08—0.11 in}** and it is connected securely.
  - If quick release connector does not move at all, verify that O-ring is not damaged and slipped, and reconnect the quick release connector.

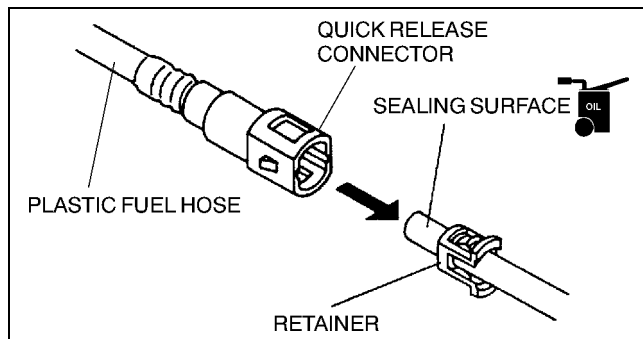

01-14

2. When the retainer is removed, perform the following procedure.

### Note

- Use the designated genuine retainer only.
- (1) Inspect the plastic fuel hose and fuel pump unit sealing surface for damage and deformation, and replace if necessary.
    - If the quick release connector O-ring is damaged or has slipped, replace the plastic fuel hose.
  - (2) Install a new retainer onto the quick release connector. Visually inspect that the tabs of the retainer are securely fitted into the quick release connector.
  - (3) Slightly apply clean engine oil to the sealing surface of the fuel pump unit.
  - (4) Push the quick release connector straight into the fuel pump unit until a click is heard.
  - (5) Lightly pull and push the quick release connector a few times by hand and verify that it can move **2.0—3.0 mm {0.08—0.11 in}** and it is connected securely.
    - If quick release connector does not move at all, verify that O-ring is not damaged and slipped, and reconnect the quick release connector.

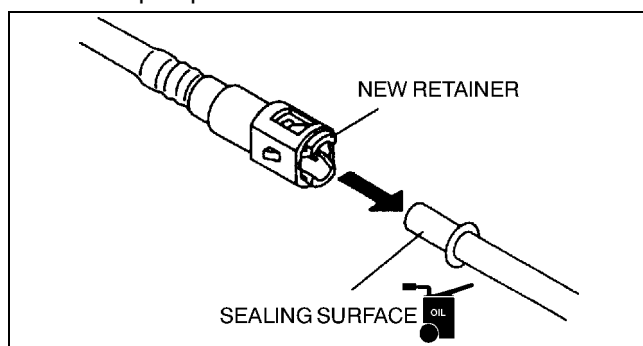

## FUEL TANK INSPECTION

A3U011442110W02

### Note

- This inspection is for the 2 rollover valves integrated in the fuel tank. The evaporative gas check valve (two-way) is integrated with each rollover valve.

1. Remove the fuel tank. (See 01-14-9 FUEL TANK REMOVAL/INSTALLATION.)
2. Connect the **SST** to an air compressor.
3. Plug the fuel main pipe and fuel return pipe of the fuel pump unit.
4. Connect the **SST** to port B and plug port A.
5. Level the fuel tank.
6. Apply pressure of **+5.9 kPa {+44 mmHg, +1.7 inHg}** to port B and verify that there is airflow from port C.
  - If there is no airflow, replace the fuel tank.
  - If there is airflow, connect the **SST** to port C with port A plugged.
7. Apply pressure of **+2.0 kPa {+15 mmHg, +0.59 inHg}** to port C and verify that there is airflow from port B.
  - If there is no airflow, replace the fuel tank.
  - If there is airflow, connect the **SST** to port B and turn the fuel tank upside-down.

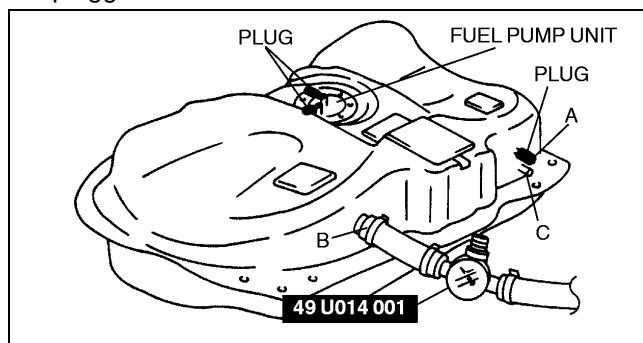



## FUEL SYSTEM

- Apply pressure of **+0.99 kPa {+7.4 mmHg, 0.29 inHg}** to port B and verify that there is no airflow from port C.
  - If there is airflow, replace the fuel tank.

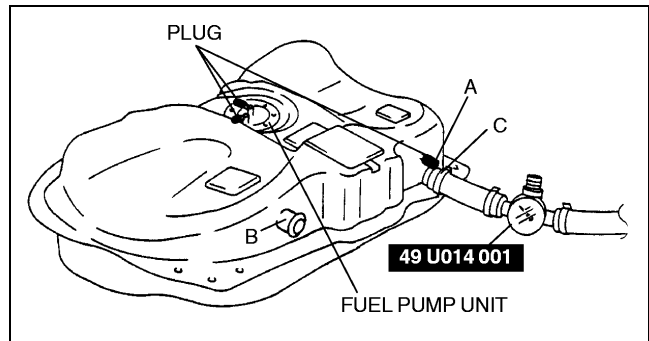

X3U114WA9

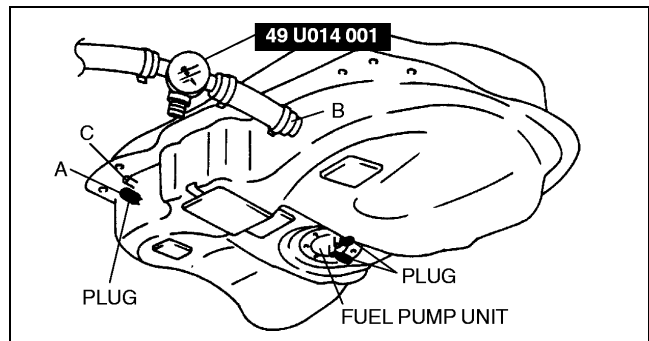

X3U114WB0

### FUEL SHUT-OFF VALVE INSPECTION

A3U011442990W01

#### Note

- The fuel shut-off valve is located in the fuel tank.
- Carry out the "FUEL TANK INSPECTION". (See 01-14-13 FUEL TANK INSPECTION.)

### NONRETURN VALVE INSPECTION

A3U011442270W01

- Remove the nonreturn valve. (See 01-14-9 FUEL TANK REMOVAL/INSTALLATION.)
- Verify that the nonreturn valve opens up to **90°** when it is pushed from the fuel-filler pipe side, and it returns to the normal position by the spring force.
  - If the nonreturn valve does not open up to **90°** or does not return to the normal position, replace the nonreturn valve.

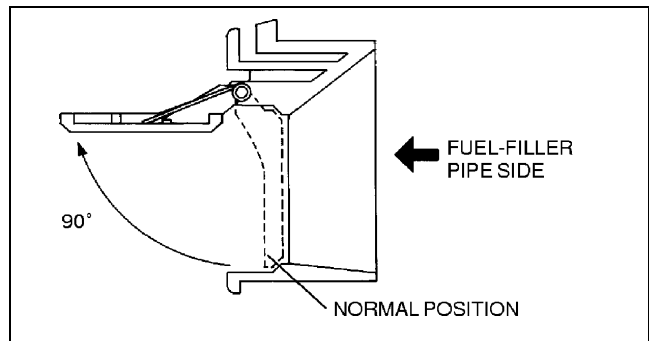

X3U114WP1

### FUEL PUMP UNIT REMOVAL/INSTALLATION

A3U011413350W01

- Remove and install the fuel pump unit. (See 01-14-9 FUEL TANK REMOVAL/INSTALLATION.)

# FUEL SYSTEM

## FUEL PUMP UNIT DISASSEMBLY/ASSEMBLY

A3U011413350W02

### Warning

- Fuel line spills and leakage are dangerous. Fuel can ignite and cause serious injuries or death and damage. Fuel can also irritate skin and eyes. To prevent this, do not damage the sealing surface of the fuel pump unit when removing or installing.

1. Disassemble in the order indicated in the table.

1	Fuel pump unit cover
2	Fuel filter (high-pressure)
3	Spacer
4	Rubber mount
5	Fuel filter (low-pressure)
6	Fuel pump body
7	Fuel gauge sender unit

2. Assemble in the reverse order of disassembly.

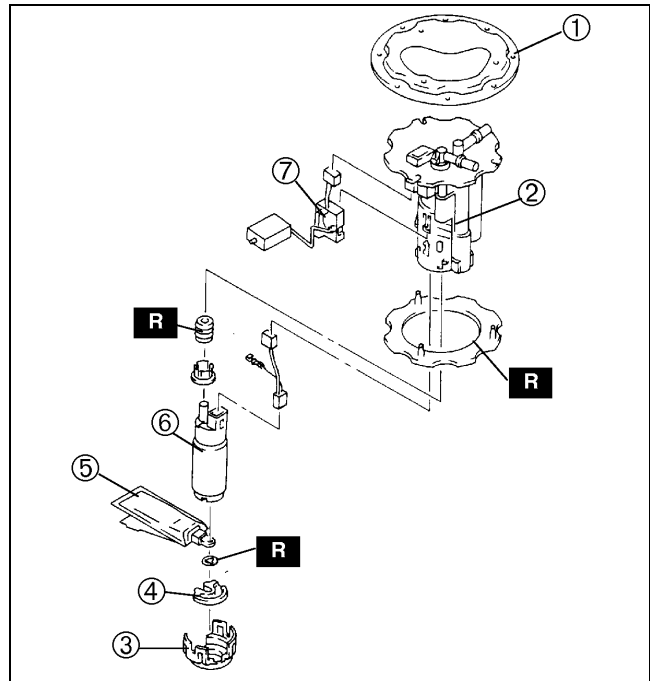

X3U114WB3

## FUEL PUMP UNIT INSPECTION

### Continuity Inspection

A3U011413350W03

### Note

- Perform the following test only when directed.

- Disconnect the negative battery cable.
- Remove the rear seat cushion. (See 09-13-5 REAR SEAT REMOVAL/INSTALLATION.)
- Remove the service hole cover.
- Disconnect the fuel pump unit connector.
- Inspect for continuity between fuel pump unit connector terminals B and D.
  - If there is no continuity, replace the fuel pump body.
  - If as specified, carry out the "Circuit Open/Short Inspection".

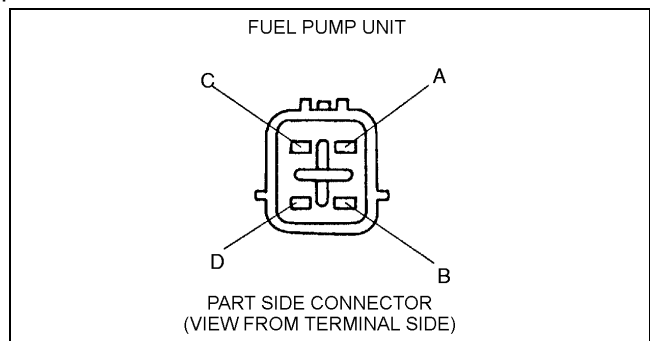

Y3U114WA6

01-14

# FUEL SYSTEM

## Circuit Open/Short Inspection

1. Remove the PCM.
2. Connect the **SST** (104 Pin Breakout Box) to the PCM as shown.
3. Tighten the connector attaching screw.

### Tightening torque

7.9—10.7 N·m {80—110 kgf·cm, 69.5—95.4 in·lbf}

4. Inspect for an open or short circuit in the following wiring harnesses by probing the applicable sensor and **SST** (104 Pin Breakout Box) terminals with ohmmeter leads.

### Open circuit

- GND circuit (Fuel pump unit connector terminal D and body GND)
- Power circuit (Fuel pump relay connector terminal C and fuel pump unit connector terminal B through common connector)

### Short circuit

- Fuel pump relay connector terminal C and fuel pump unit connector terminal B through common connector to GND

5. Repair or replace faulty areas.
6. Reconnect the fuel pump unit connector.
7. Install the service hole cover.
8. Install the rear seat cushion.
9. Reconnect the negative battery cable.

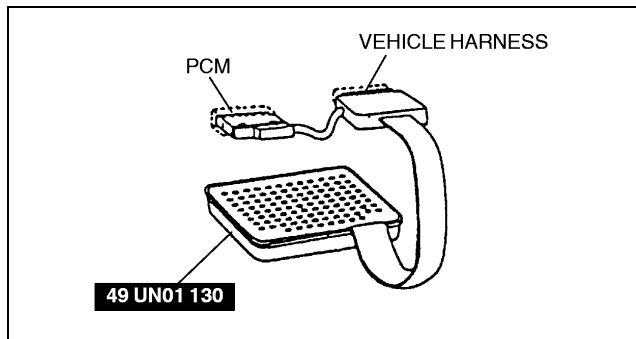

Y3U114WB7

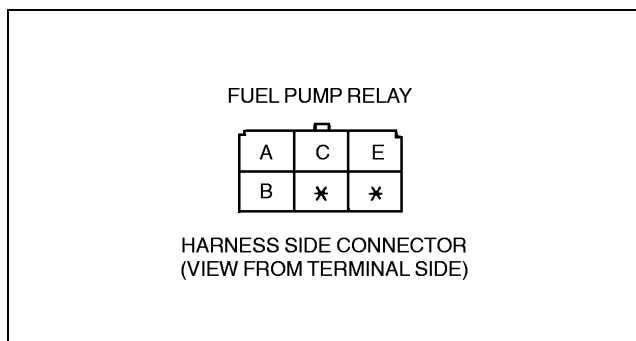

X3U114WB5

# FUEL SYSTEM

## Fuel Pump Maximum Pressure Inspection

### Warning

- Fuel line spills and leakage are dangerous. Fuel can ignite and cause serious injuries or death and damage. Always carry out the following procedure with the engine stopped.

### Caution

- Disconnecting/connecting the quick release connector without cleaning it may possibly cause damage to the fuel pipe and quick release connector. Always clean the quick release connector joint area before disconnecting/connecting, and make sure that it is free of foreign material.

01-14

### Note

- Perform the following test only when directed.

1. Complete the "BEFORE REPAIR PROCEDURE". (See 01-14-4 BEFORE REPAIR PROCEDURE.)
2. Disconnect the negative battery cable.
3. Disconnect the quick release connector from the pulsation damper as follows:
  - (1) Push the tab on the orange locking coupler 90° until it stops.
  - (2) Pull the fuel hose straight back.

### Note

- The blue stopper may be removed from the quick connector. Take care not to lose it. Reinstall it to the quick release connector before reconnecting the fuel line.

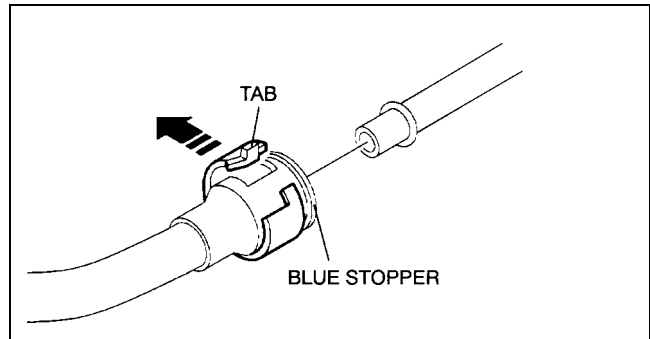

Z3U0114W986

- The orange locking coupler has two internal locking tabs which restrain the pulsation damper pipe. Be sure that the tab on the locking coupler is rotated until it stops to release two internal locking tabs.

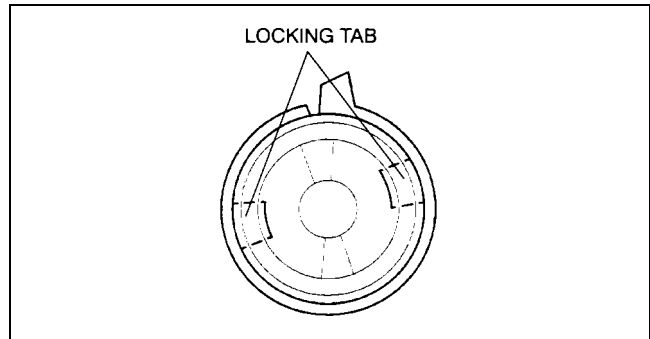

Z3U0114W993

## FUEL SYSTEM

- Turn the lever to plug the **SST** outlet.
- Push the **SST** quick release connector into the fuel main pipe until a click is heard.
- Set the fuel hose into a container to avoid fuel spills.

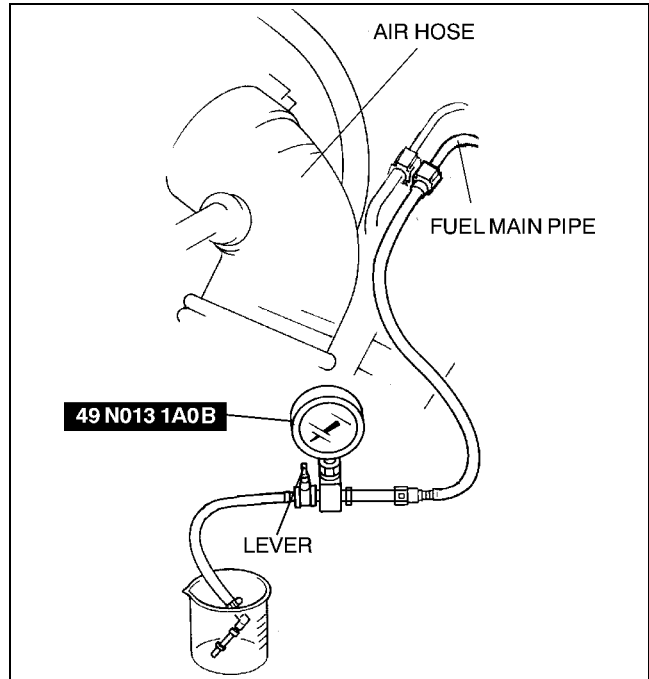

Z3U0114W001

- Connect the negative battery cable.

### Caution

- Connecting to the wrong DLC terminal may possibly cause a malfunction. Carefully connect to the specified terminal only.

- Short the DLC terminal F/P to the body GND using a jumper wire.
- Turn the ignition switch to ON to operate the fuel pump body.
- Measure the fuel pump maximum pressure.
  - If not as specified, inspect the following:
    - Fuel pump relay
    - Fuel filters (low-pressure, high-pressure) for clogging
    - Fuel line for clogging or leakage

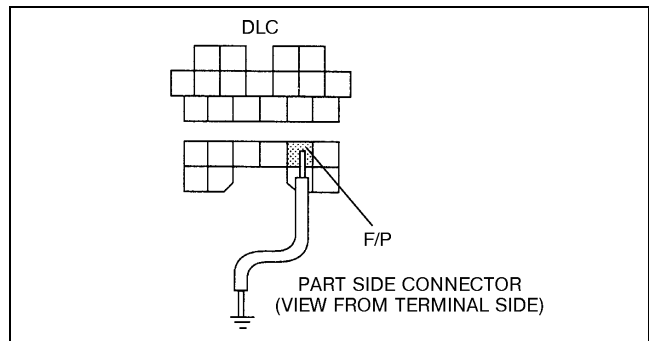

Y3U114WA7

### Fuel pump maximum pressure

450—630 kPa {4.5—6.5 kgf/cm<sup>2</sup>, 64—92 psi}

- Turn the ignition switch off and disconnect the jumper wire.
- Disconnect the **SST**.

### Note

- A checker tab is integrated with the quick release connector for new plastic fuel hoses. The checker tab will be released from the quick release connector after it is completely engaged with the fuel pipe.

- Inspect the plastic fuel hose and fuel pipe sealing surface for damage and deformation, and replace if necessary.

- If the quick release connector O-ring is damaged or has slipped, replace the plastic fuel hose.

- Reconnect the fuel main hose to the fuel main pipe until a click is heard.

- Pull the quick release connector by hand and verify that it is installed securely.

- Complete the "AFTER REPAIR PROCEDURE". (See 01-14-5 AFTER REPAIR PROCEDURE.)

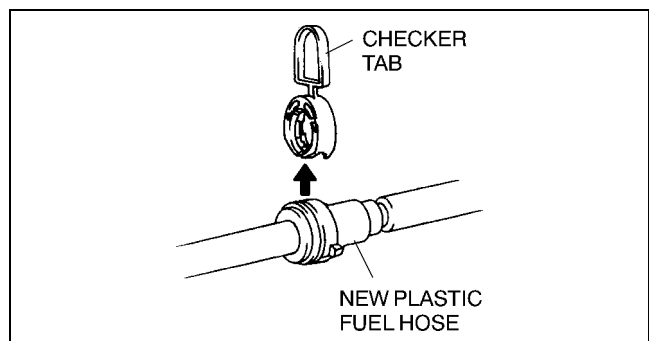

YMU114WA8

# FUEL SYSTEM

## Fuel Pump Hold Pressure Inspection

### Warning

- Fuel line spills and leakage are dangerous. Fuel can ignite and cause serious injuries or death and damage. Always carry out the following procedure with the engine stopped.

### Caution

- Disconnecting/connecting the quick release connector without cleaning it may possibly cause damage to the fuel pipe and quick release connector. Always clean the quick release connector joint area before disconnecting/connecting, and make sure that it is free of foreign material.

01-14

### Note

- Perform the following test only when directed.

1. Complete the "BEFORE REPAIR PROCEDURE". (See 01-14-4 BEFORE REPAIR PROCEDURE.)
2. Disconnect the negative battery cable.
3. Disconnect the quick release connector from the pulsation damper as follows:
  - (1) Push the tab on the orange locking coupler 90° until it stops.
  - (2) Pull the fuel hose straight back.

### Note

- The blue stopper may be removed from the quick connector. Take care not to lose it. Reinstall it to the quick release connector before reconnecting the fuel line.

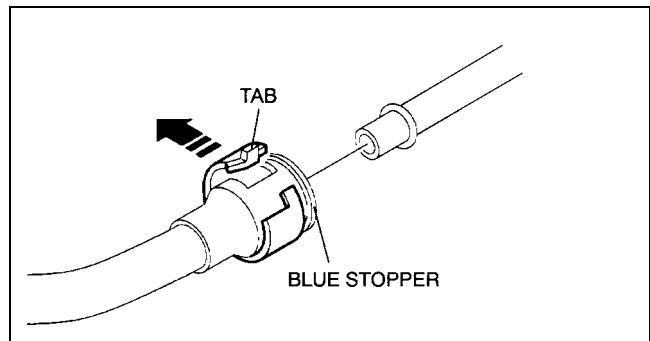

Z3U0114W986

- The orange locking coupler has two internal locking tabs which restrain the pulsation damper pipe. Be sure that the tab on the locking coupler is rotated until it stops to release two internal locking tabs.

4. Turn the lever as shown to plug the **SST** outlet.
5. Push the **SST** quick release connector into the fuel main pipe until a click is heard.

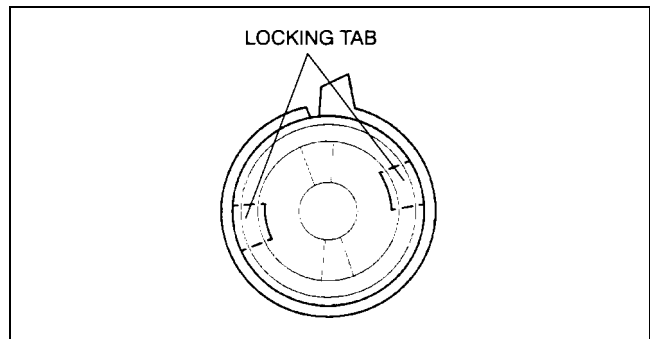

Z3U0114W993

## FUEL SYSTEM

- Set the fuel hose into a container to avoid fuel spills.

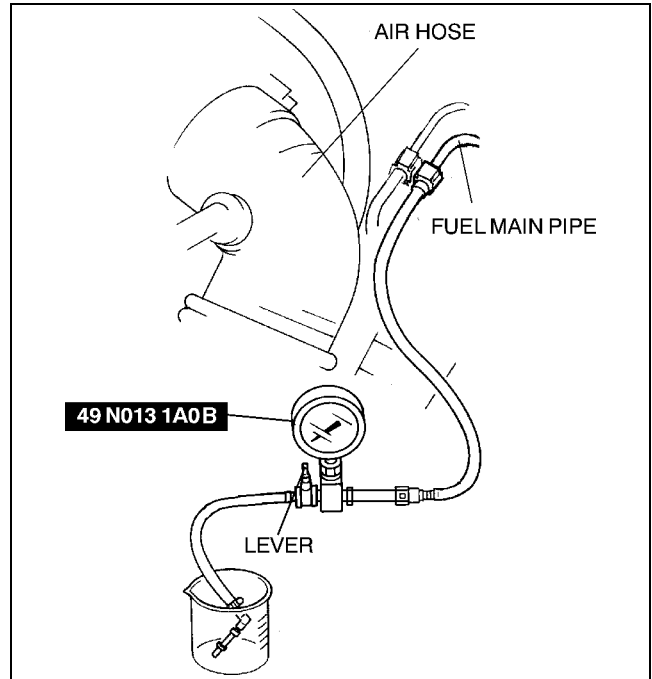

Z3U0114W001

- Connect the negative battery cable.

### Caution

- Connecting to the wrong DLC terminal may possibly cause a malfunction. Carefully connect to the specified terminal only.

- Short the DLC terminal F/P to the body GND using a jumper wire.
- Turn the ignition switch to ON for **10 s** to operate the fuel pump body.
- Turn the ignition switch off.
- Measure the fuel pump hold pressure **after 5 min.**

- If not as specified, carry out the "PRESSURE REGULATOR INSPECTION", "FUEL INJECTOR INSPECTION". (See 01-14-28 PRESSURE REGULATOR INSPECTION.) (See 01-14-24 FUEL INJECTOR INSPECTION.) Verify that there is no fuel leakage from the quick release connector joint areas.
- If all items above are okay, replace the fuel pump body. (See 01-14-15 FUEL PUMP UNIT DISASSEMBLY/ASSEMBLY.)

### Fuel pump hold pressure

**More than 340 kPa {3.5 kgf/cm<sup>2</sup>, 50 psi}**

- Disconnect the jumper wire.
- Disconnect the **SST**.

### Note

- A checker tab is integrated with the quick release connector for new plastic fuel hoses. The checker tab will be released from the quick release connector after it is completely engaged with the fuel pipe.

- Inspect the plastic fuel hose and fuel pipe sealing surface for damage and deformation, and replace if necessary.
  - If the quick release connector O-ring is damaged or has slipped, replace the plastic fuel hose.

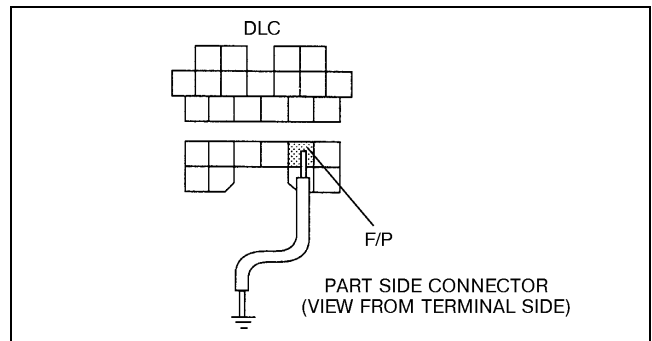

Y3U114WA8

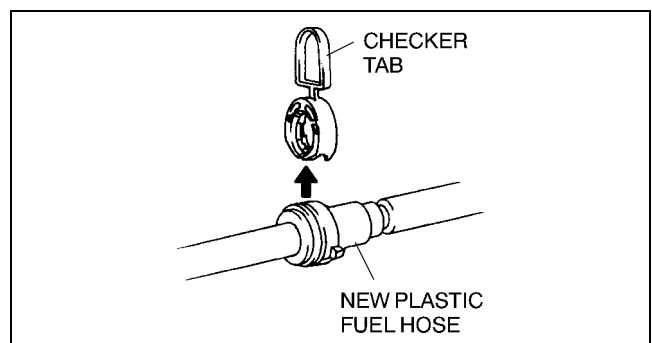

YMU114WA8

# FUEL SYSTEM

15. Reconnect the fuel main hose to the fuel main pipe until a click is heard.
16. Pull the quick release connector by hand and verify that it is installed securely.
17. Complete the "AFTER REPAIR PROCEDURE". (See 01-14-5 AFTER REPAIR PROCEDURE.)

## FUEL FILTER (HIGH-PRESSURE) REMOVAL/INSTALLATION

A3U011434801W01

1. Remove and install the fuel filter (high-pressure). (See 01-14-15 FUEL PUMP UNIT DISASSEMBLY/ASSEMBLY.)

## FUEL INJECTOR REMOVAL/INSTALLATION

A3U011413250W01

### Caution

- **Disconnecting/connecting the quick release connector without cleaning it may possibly cause damage to the fuel pipe and quick release connector. Always clean the quick release connector joint area before disconnecting/connecting, and make sure that it is free of foreign material.**

1. Complete the "BEFORE REPAIR PROCEDURE". (See 01-14-4 BEFORE REPAIR PROCEDURE.)
2. Disconnect the battery negative cable.
3. Remove the accelerator cable bracket. (See 01-13A-5 INTAKE-AIR SYSTEM REMOVAL/INSTALLATION [ZM].) (See 01-13B-6 INTAKE-AIR SYSTEM REMOVAL/INSTALLATION [FS].)
4. Disconnect the fuel injector connectors and remove the harness from the fuel distributor.
5. Remove in the order indicated in the table.
6. Install in the reverse order of removal.
7. Complete the "AFTER REPAIR PROCEDURE". (See 01-14-5 AFTER REPAIR PROCEDURE.)

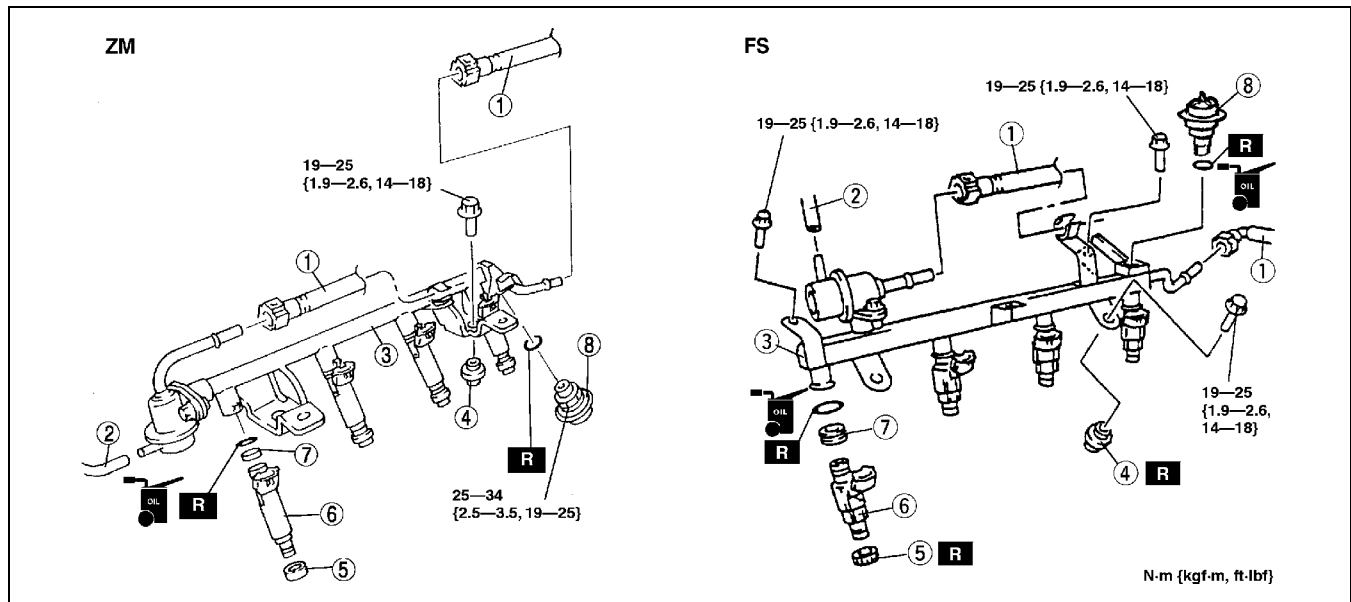

Z3U0114W995

1	Plastic fuel hose (See 01-14-22 Plastic Fuel Hose Removal Note) (See 01-14-23 Plastic Fuel Hose Installation Note)
2	Vacuum hose
3	Fuel distributor
4	Fuel distributor insulator

5	Fuel injector insulator
6	Fuel injector (See 01-14-23 Fuel Injector Installation Note (FS only))
7	Grommet
8	Pulsation damper



# FUEL SYSTEM

## Plastic Fuel Hose Removal Note

### Caution

- The quick release connector may be damaged when the tab is bent excessively. Do not expand the tab over the stopper.

1. Disconnect the quick release connector from the pulsation damper as follows:

(1) Push apart the lock clip and unlock it.

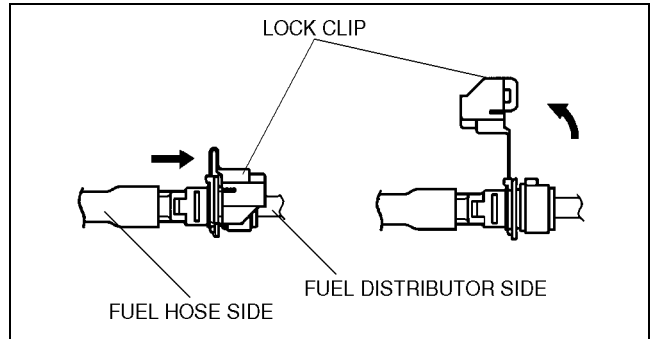

(2) Lift the tab on the blue locking coupler until the fuel line can be released.

(3) Pull the fuel hose straight back.

### Note

- The blue stopper may be removed from the quick connector. Take care not to lose it. Reinstall it to the quick release connector before reconnecting the fuel line.

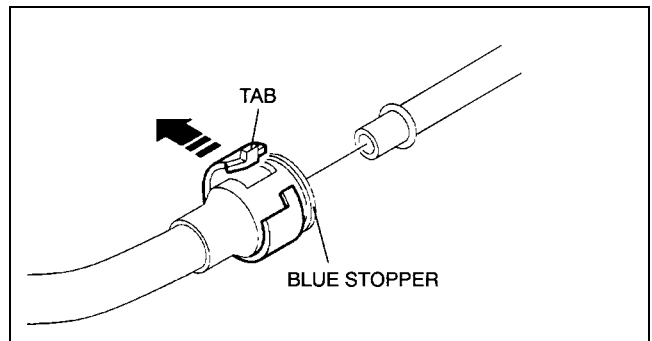

- The orange locking coupler has two internal locking tabs which restrain the pulsation damper pipe. Be sure that the tab on the locking coupler is rotated until it stops to release two internal locking tabs.

2. Cover the disconnected quick release connector and pulsation damper with vinyl sheet or the like to prevent it from being scratched or contaminated with foreign materials.

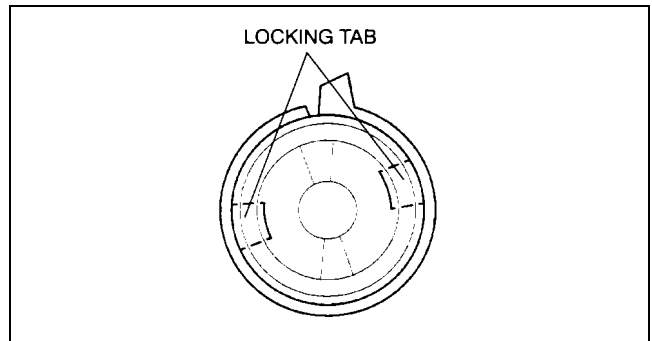

## Plastic Fuel Hose Installation Note

### Note

- A checker tab is integrated with the quick release connector for new plastic fuel hoses. The checker tab will be released from the quick release connector after it is completely engaged with the pulsation damper.

1. Inspect the plastic fuel hose and pulsation damper sealing surface for damage and deformation, and replace if necessary.
  - If the quick release connector O-ring is damaged or has slipped, replace the plastic fuel hose.
2. Apply a small amount of clean engine oil to the sealing surface of the pulsation damper.
3. Push the quick release connector straight into the pulsation damper until a click is heard.
4. Lightly pull and push the quick release connector a few times by hand and verify that it can move **2.0—3.0 mm {0.08—0.11 in}** and it is connected securely.
  - If quick release connector does not move at all, verify that O-ring is not damaged and slipped, and reconnect the quick release connector.
5. Attach the lock clip to the quick release connector in the direction of the fuel distributor and lock it, as shown in the figure.

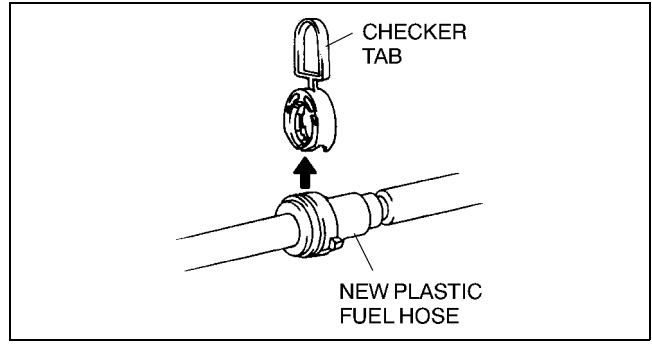

YMU114WA8

01-14

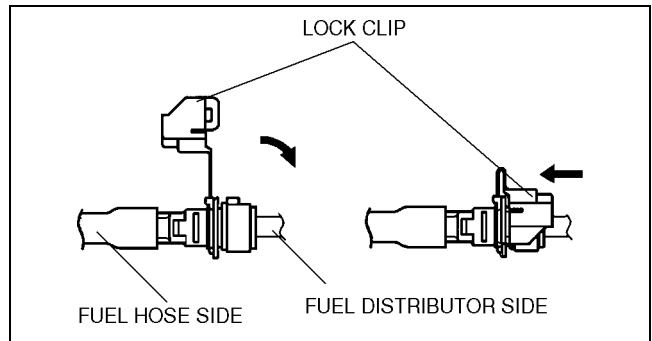

Y3E3912W202

## Fuel Injector Installation Note (FS only)

1. Install each fuel injector as indicated in the table.

Cylinder number	Fuel injector body color
No.1, No.2 cylinder	Green
No.3, No.4 cylinder	Purple

2. Use new fuel injector O-rings.
3. Apply a small amount of engine oil to the O-rings and install them on the fuel distributor.
4. Verify that the O-rings and the fuel injector sealing surfaces are free of foreign material. Clean with gasoline if necessary.
5. Align the fuel injector notch with the fuel distributor and install the fuel injectors on the fuel distributor with a light twisting motion so that the O-rings will not be folded.

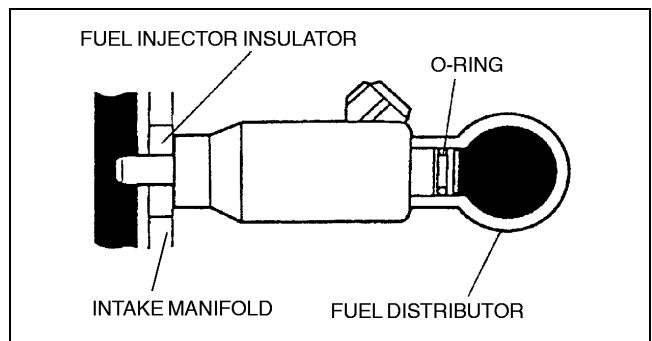

X3U114WC6

# FUEL SYSTEM

## FUEL INJECTOR INSPECTION

A3U011413250W02

### Simulation Test

1. Carry out the "Fuel Injector Operation Inspection". (See 01-03A-60 Fuel Injector Operation Inspection.) (See 01-03B-59 Fuel Injector Operation Inspection.)
  - If not as specified, perform the further inspection for the fuel injectors.

### Resistance Inspection

#### Note

- Perform the following test only when directed.

1. Turn the ignition switch off.
2. Disconnect the battery negative cable.
3. Disconnect the fuel injector connectors.
4. Measure the resistance of the fuel injector using an ohmmeter.
  - If not as specified, replace the fuel injector. (See 01-14-21 FUEL INJECTOR REMOVAL/INSTALLATION.)
  - If as specified but "Simulation Test" is failed, carry out the "Circuit Open/Short Inspection".

#### Resistance [20 °C {68 °F}]

ZM: Approx.13.8 ohms

FS: 14.2—14.8 ohms

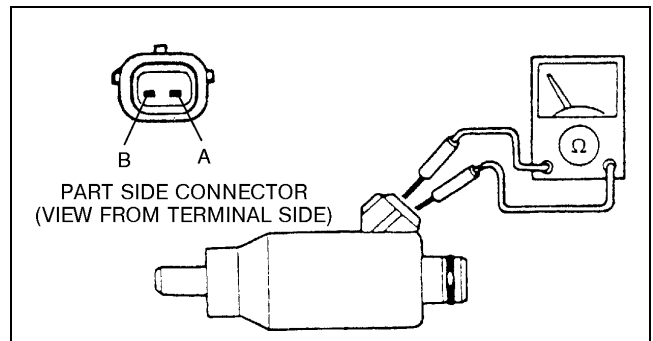

Y3U114WA9

### Circuit Open/Short Inspection

1. Disconnect the PCM connector.
2. Connect the **SST** (104 Pin Breakout Box) to the PCM as shown.
3. Tighten the connector attaching screw.

#### Tightening torque

7.9—10.7 N·m {80—110 kgf·cm, 69.5—95.4 in·lbf}

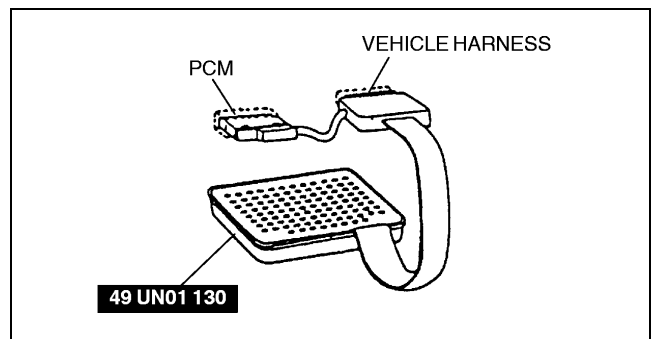

Y3U114WB8

4. Inspect for an open or short circuit in the following wiring harnesses by probing the applicable sensor and **SST** (104 Pin Breakout Box) terminals with ohmmeter leads.

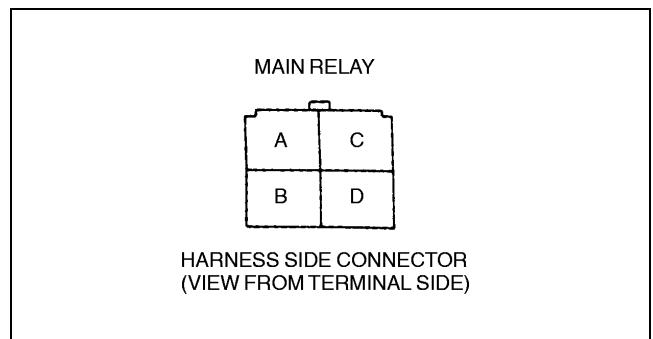

X3U114WC8

## Open circuit

- GND circuit (No.1 cylinder fuel injector connector terminal B and PCM connector terminal 75)
- GND circuit (No.2 cylinder fuel injector connector terminal B and PCM connector terminal 101)
- GND circuit (No.3 cylinder fuel injector connector terminal B and PCM connector terminal 74)
- GND circuit (No.4 cylinder fuel injector connector terminal B and PCM connector terminal 100)
- Power circuit (No.1 cylinder fuel injector connector terminal A and main relay connector terminal D through common connector)
- Power circuit (No.2 cylinder fuel injector connector terminal A and main relay connector terminal D through common connector)
- Power circuit (No.3 cylinder fuel injector connector terminal A and main relay connector terminal D through common connector)
- Power circuit (No.4 cylinder fuel injector connector terminal A and main relay connector terminal D through common connector)

## Short circuit

- No.1 cylinder fuel injector connector terminal B and PCM connector terminal 75 to GND
- No.2 cylinder fuel injector connector terminal B and PCM connector terminal 101 to GND
- No.3 cylinder fuel injector connector terminal B and PCM connector terminal 74 to GND
- No.4 cylinder fuel injector connector terminal B and PCM connector terminal 100 to GND

5. Repair or replace faulty areas.
6. Reconnect the fuel injector connectors.
7. Reconnect the battery negative cable.

## Fuel Leakage Test

### Warning

- **Fuel line spills and leakage are dangerous. Fuel can ignite and cause serious injuries or death and damage. Always carry out the following procedure with the engine stopped.**

### Note

- Perform the following test only when directed.

1. Complete the "BEFORE REPAIR PROCEDURE". (See 01-14-4 BEFORE REPAIR PROCEDURE.)
2. Disconnect the battery negative cable.
3. Remove the fuel injectors together with the fuel distributor. (See 01-14-21 FUEL INJECTOR REMOVAL/INSTALLATION.)
4. Fasten the fuel injectors firmly to the fuel distributor with wires.

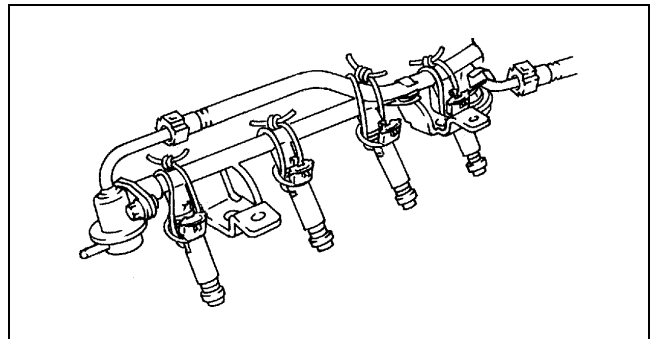

X3U114WC9

5. Connect the battery negative cable.

### Caution

- **Connecting to the wrong DLC terminal may possibly cause a malfunction. Carefully connect to the specified terminal only.**

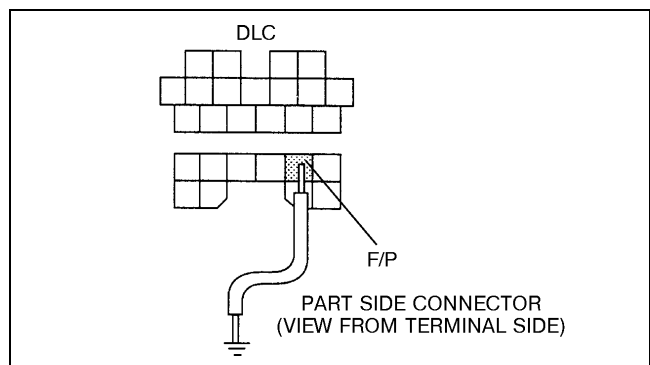

Y3U114WAA

## FUEL SYSTEM

- Short the DLC terminal F/P to the body GND using a jumper wire.
- Turn the ignition switch to ON to operate the fuel pump body.
- Tilt the fuel injectors **approx. 60 degrees** and verify that fuel leakage from the fuel injector nozzles is within the specification.
  - If not as specified, replace the fuel injector.

### Fuel leakage

Less than 1 drop/2 min

- Turn the ignition switch off and remove the jumper wire.
- Complete the "AFTER REPAIR PROCEDURE". (See 01-14-5 AFTER REPAIR PROCEDURE.)

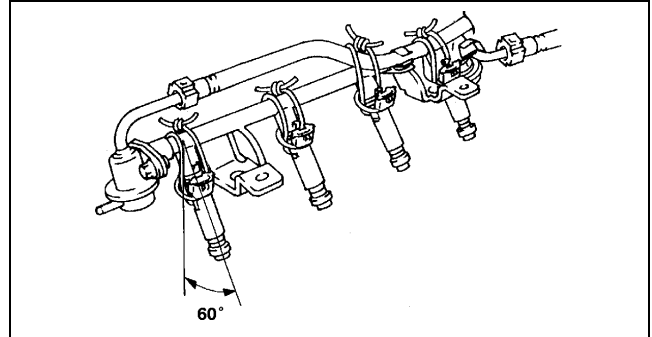

X3U114WD0

### Volume Test

#### Warning

- Fuel line spills and leakage are dangerous. Fuel can ignite and cause serious injuries or death and damage. Always carry out the following procedure with the engine stopped.

#### Note

- Perform the following test only when directed.
- If you have an after market fuel injector tester or **SST** (49 L018 901), perform this inspection.
- If there is no an after market fuel injector tester available, perform "Simulation Test", "Resistance Inspection", and "Fuel Leakage Inspection" to verify whether the fuel injector is okay or not.

- Complete the "BEFORE REPAIR PROCEDURE". (See 01-14-4 BEFORE REPAIR PROCEDURE.)
- Disconnect the battery negative cable.

### Using the SST

- Remove the fuel injectors together with the fuel distributor with connected to fuel hose. (See 01-14-21 FUEL INJECTOR REMOVAL/INSTALLATION.)
- Fasten the fuel injectors firmly to the fuel distributor with wires.
- Connect the fuel injector to the **SST** or the fuel injector tester as shown in the figure.

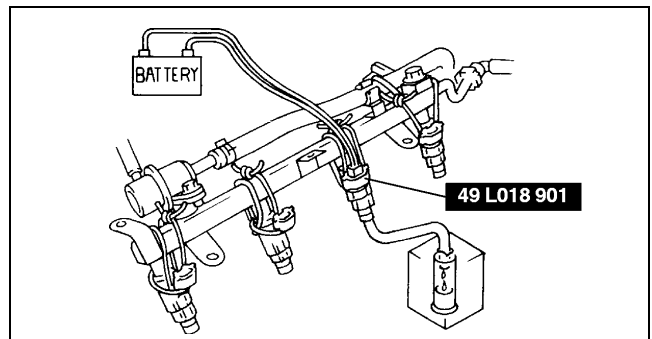

X3U114WJ4

## FUEL SYSTEM

4. Connect the battery negative cable.

### Caution

- **Connecting to the wrong DLC terminal may possibly cause a malfunction. Carefully connect to the specified terminal only.**

5. Short the DLC terminal F/P to body GND using a jumper wire.
6. Turn the ignition switch to ON.
7. Measure the injection volume of each fuel injector using a graduated container.
  - If not as specified, replace the fuel injector.

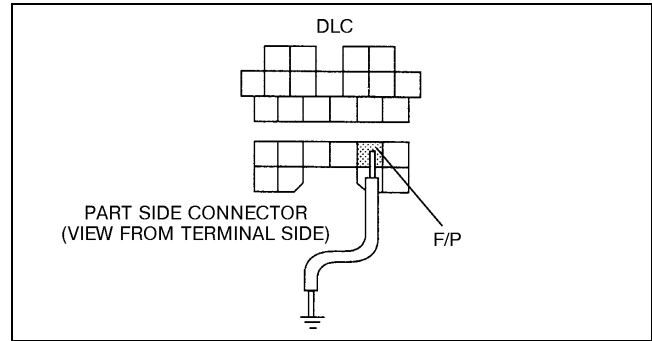

Y3U114WAW

01-14

### Injection volume

**ZM: 38.1—40.4 ml {38.1—40.4 cc, 1.29—1.36 fl oz}/15 s**

**FS: 68—75 ml {68—75 cc, 2.30—2.53 fl oz}/15 s**

8. Turn the ignition switch to LOCK.
9. Disconnect the battery negative cable.
10. Disconnect the **SST** or the fuel injector tester from the fuel injector.
11. Disconnect the jumper wire.
12. Complete the "AFTER REPAIR PROCEDURE". (See 01-14-5 AFTER REPAIR PROCEDURE.)

### Using a Fuel Injector Tester

1. Remove the fuel injectors. (See 01-14-21 FUEL INJECTOR REMOVAL/INSTALLATION.)
2. Connect the fuel injector to a fuel injector tester.
3. Measure the injection volume of each fuel injector.
  - If not as specified, replace the fuel injector.

### Injection volume

**ZM: 38.1—40.4 ml {38.1—40.4 cc, 1.29—1.36 fl oz}/15 s**

**FS: 68—75 ml {68—75 cc, 2.3—2.5 fl oz}/15 s**

4. Complete the "AFTER REPAIR PROCEDURE". (See 01-14-5 AFTER REPAIR PROCEDURE.)

## PRESSURE REGULATOR REMOVAL/INSTALLATION

A3U011413280W01

### Caution

- **Disconnecting/connecting the quick release connector without cleaning it may possibly cause damage to the fuel pipe and quick release connector. Always clean the quick release connector joint area before disconnecting/connecting, and make sure that it is free of foreign material.**

1. Complete the "BEFORE REPAIR PROCEDURE". (See 01-14-4 BEFORE REPAIR PROCEDURE.)
2. Disconnect the battery negative cable.

# FUEL SYSTEM

3. Remove in the order indicated in the table.

1	Vacuum hose
2	Plastic fuel hose (See 01-14-22 Plastic Fuel Hose Removal Note) (See 01-14-23 Plastic Fuel Hose Installation Note)
3	Pressure regulator

4. Install in the reverse order of removal.
5. Complete the "AFTER REPAIR PROCEDURE".  
(See 01-14-5 AFTER REPAIR PROCEDURE.)

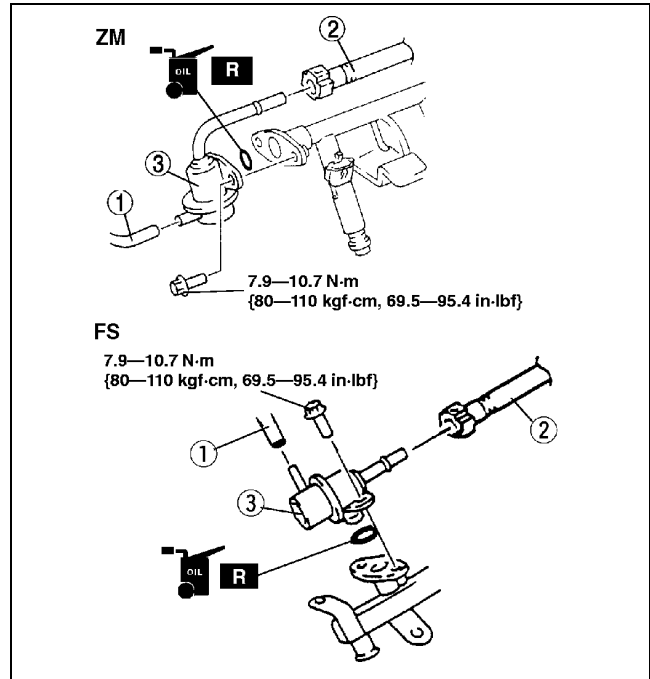

Z3U0114W992

## PRESSURE REGULATOR INSPECTION

A3U011413280W02

### Caution

- Disconnecting/connecting the quick release connector without cleaning it may possibly cause damage to the fuel pipe and quick release connector. Always clean the quick release connector joint area before disconnecting/connecting, and make sure that it is free of foreign material.

### Simulation Test

1. Carry out the "FUEL PRESSURE INSPECTION". (See 01-14-6 FUEL PRESSURE INSPECTION.)
  - If not as specified, perform the further inspection for the pressure regulator.

### Operation Inspection

#### Note

- Perform the following test only when directed.

1. Complete the "BEFORE REPAIR PROCEDURE". (See 01-14-4 BEFORE REPAIR PROCEDURE.)
2. Disconnect the battery negative cable.
3. Disconnect the quick release connector from the pulsation damper as follows:
  - (1) Push apart the lock clip and unlock it.

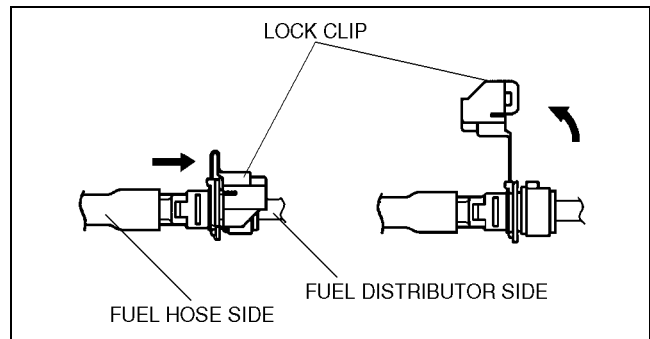

Y3E3912W201

## FUEL SYSTEM

- (2) Lift the tab on the blue locking coupler until the fuel line can be released.
- (3) Pull the fuel hose straight back.

### Note

- The blue stopper may be removed from the quick connector. Take care not to lose it. Reinstall it to the quick release connector before reconnecting the fuel line.

- The orange locking coupler has two internal locking tabs which retain the pulsation damper pipe. Be sure that the tab on the locking coupler is rotated until it stops to release two internal locking tabs.

4. Push the **SST** quick release connector into the fuel distributor and fuel main hose into the **SST** until a click is heard.

5. Turn the lever on the **SST** as shown.
6. Connect the battery negative cable.
7. Start the engine and let it idle.
8. Measure the fuel line pressure **after approx. 2 min.**

### Fuel line pressure

210—250 kPa {2.1—2.6 kgf/cm<sup>2</sup>, 30—36 psi}

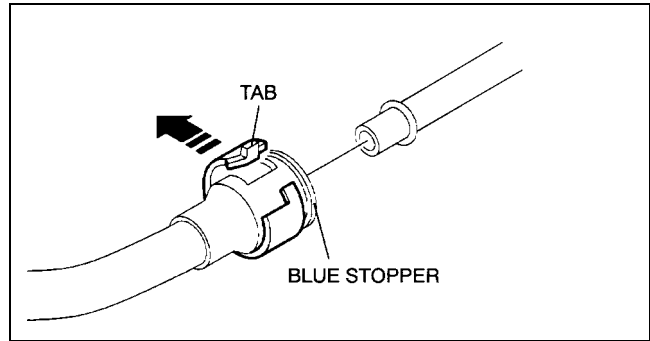

Z3U0114W986

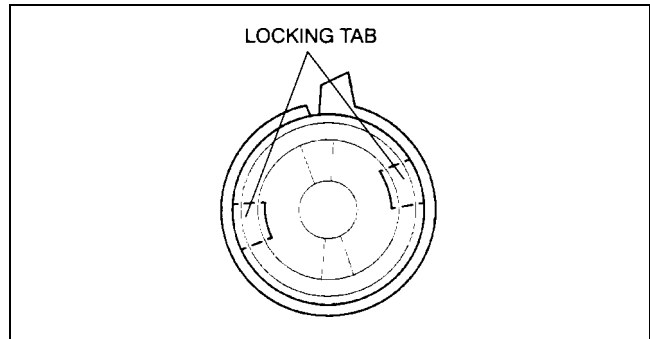

Z3U0114W993

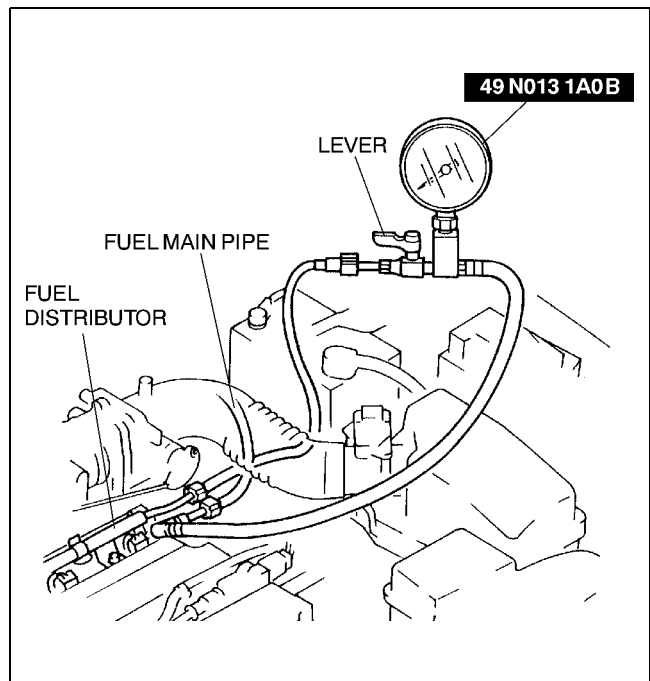

Y3U114WB4



## FUEL SYSTEM

- Disconnect the vacuum hose from the pressure regulator and measure the fuel line pressure.

### Fuel line pressure

270—310 kPa {2.7—3.2 kgf/cm<sup>2</sup>, 39—45 psi}

- Turn the ignition switch off.

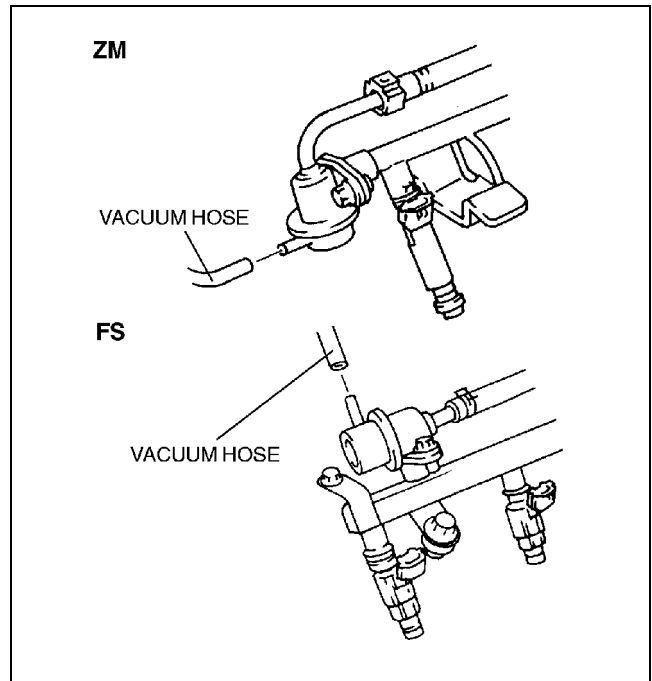

Z3U0114W989

- Disconnect the **SST**.

### Note

- A checker tab is integrated with the quick release connector for new plastic fuel hoses. The checker tab will be released from the quick release connector after it is completely engaged with the fuel pipe.

- Inspect the plastic fuel hose and pulsation damper sealing surface for damage and deformation, and replace if necessary.

- If the quick release connector O-ring is damaged or has slipped, replace the plastic fuel hose.

- Apply a small amount of clean engine oil to the sealing surface of the pulsation damper.

- Reconnect the plastic fuel hose straight to the pulsation damper until a click is heard.

- Lightly pull and push the quick release connector a few times by hand and verify that it can move **2.0—3.0 mm {0.08—0.11 in}** and it is connected securely.

- If quick release connector does not move at all, verify that O-ring is not damaged and slipped, and reconnect the quick release connector.

- Attach the lock clip to the quick release connector in the direction of the fuel distributor and lock it, as shown in the figure.

- Complete the "AFTER REPAIR PROCEDURE". (See 01-14-5 AFTER REPAIR PROCEDURE.)

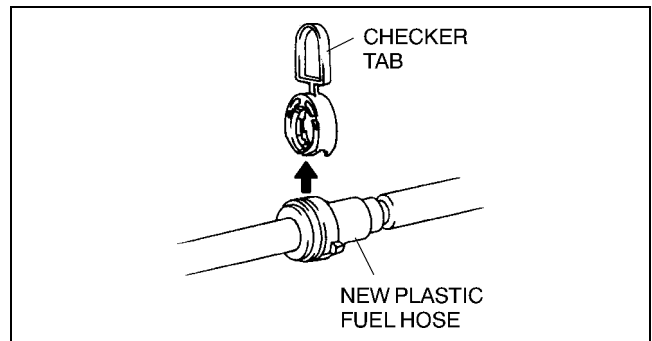

YMU114WA8

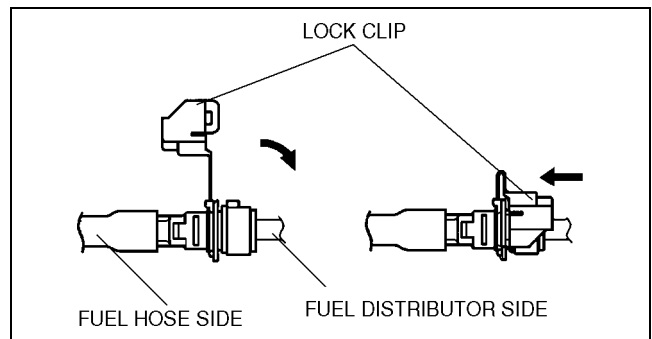

Y3E3912W202

## PULSATION DAMPER REMOVAL/INSTALLATION

A3U011420180W01

- Remove and install the pulsation damper. (See 01-14-21 FUEL INJECTOR REMOVAL/INSTALLATION.)

## PULSATION DAMPER INSPECTION

A3U011420180W02

1. Remove the pulsation damper. (See 01-14-21 FUEL INJECTOR REMOVAL/INSTALLATION.)
2. Visually inspect the pulsation damper for damage and cracks. Also inspect that there is no extreme rust which will cause fuel leakage.
  - If either is observed, replace the pulsation damper.

## PRC SOLENOID VALVE REMOVAL/INSTALLATION

A3U011418740W01

1. Remove and install the PRC solenoid valve.
  - Remove the PRC solenoid valve from the intake manifold. (See 01-13A-5 INTAKE-AIR SYSTEM REMOVAL/INSTALLATION [ZM].)

## PRC SOLENOID VALVE INSPECTION

A3U011418740W02

### Airflow Inspection

#### Note

- Perform the following test only as directed.
1. Carry out the "Pressure Regulator Control Inspection". (See 01-03A-59 Pressure Regulator Control Inspection.) (See 01-03B-58 Pressure Regulator Control Inspection.)
    - If not as specified, perform the further inspection for the PRC solenoid valve.
  2. Disconnect the negative battery cable.
  3. Remove the PRC solenoid valve.
  4. Inspect airflow between each port under the following conditions.
    - If not as specified, replace the PRC solenoid valve.
    - If as specified but the "Pressure Regulator Control Inspection" failed, carry out the "Circuit Open/Short Inspection".
      - If there is an open or short circuit, repair or replace wiring harnesses.
      - If there is no open or short circuit, replace PRC solenoid valve.

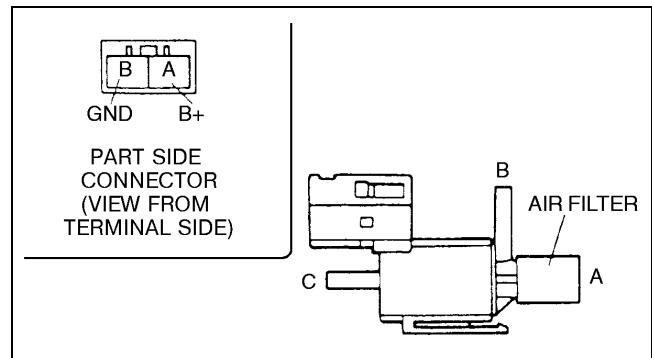

Y3U114WAC

○—○ : Continuity    ○=○ : Airflow

Step	Terminal		Port		
	A	B	A	B	C
1	○—○	○—○		○=○	○=○
2	B+	GND	○—○	○—○	

X3U114WE8

## FUEL SYSTEM

### Circuit Open/Short Inspection

1. Remove the PCM.
2. Connect the **SST** (104 Pin Breakout Box) to the PCM as shown.
3. Tighten the connector attaching screw.

#### Tightening torque

**7.9—10.7 N·m {80—110 kgf·cm, 69.5—95.4 in·lbf}**

4. Inspect for an open or short circuit in the following wiring harnesses by probing the applicable sensor and **SST** (104 Pin Breakout Box) terminals with ohmmeter leads.

#### Open circuit

- Power circuit (PRC solenoid valve connector terminal A and main relay connector terminal D through common connector)
- GND circuit (PRC solenoid valve connector terminal B and PCM connector terminal 95)

#### Short circuit

- Power circuit (PRC solenoid valve connector terminal A and main relay connector terminal D through common connector to GND)
- GND circuit (PRC solenoid valve connector terminal B and PCM connector terminal 95 to GND)

5. Reconnect the PRC solenoid valve connector.
6. Reconnect the negative battery cable.

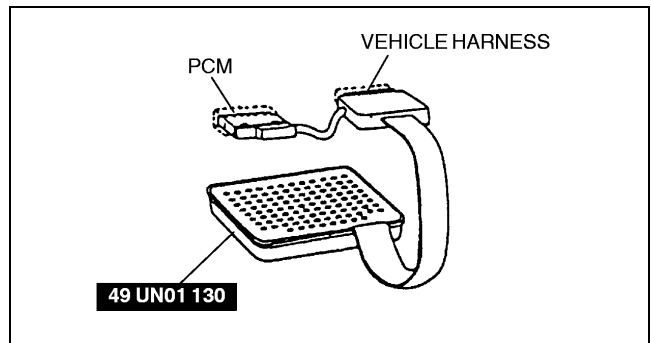

Y3U114W/B9

# 01-15 EXHAUST SYSTEM

EXHAUST SYSTEM INSPECTION ..... 01-15-1  
 EXHAUST SYSTEM  
 REMOVAL/INSTALLATION ..... 01-15-1  
 ZM ..... 01-15-1

FS ..... 01-15-2  
 Exhaust Manifold Removal Note ..... 01-15-2  
 Exhaust Manifold Gasket  
 Installation Note ..... 01-15-3

## EXHAUST SYSTEM INSPECTION

A3U01154000W01

1. Start the engine and inspect each exhaust system component for exhaust gas leakage.
  - If leakage is found, repair or replace if necessary.

## EXHAUST SYSTEM REMOVAL/INSTALLATION

A3U01154000W02

### Warning

- Hot engine and exhaust system can cause serious burn. Turn off the engine and wait until it and the exhaust system are cool before removing the exhaust system.

1. Disconnect the battery negative cable.
2. Remove in the order indicated in the table.
3. Install in the reverse order of removal.

### ZM

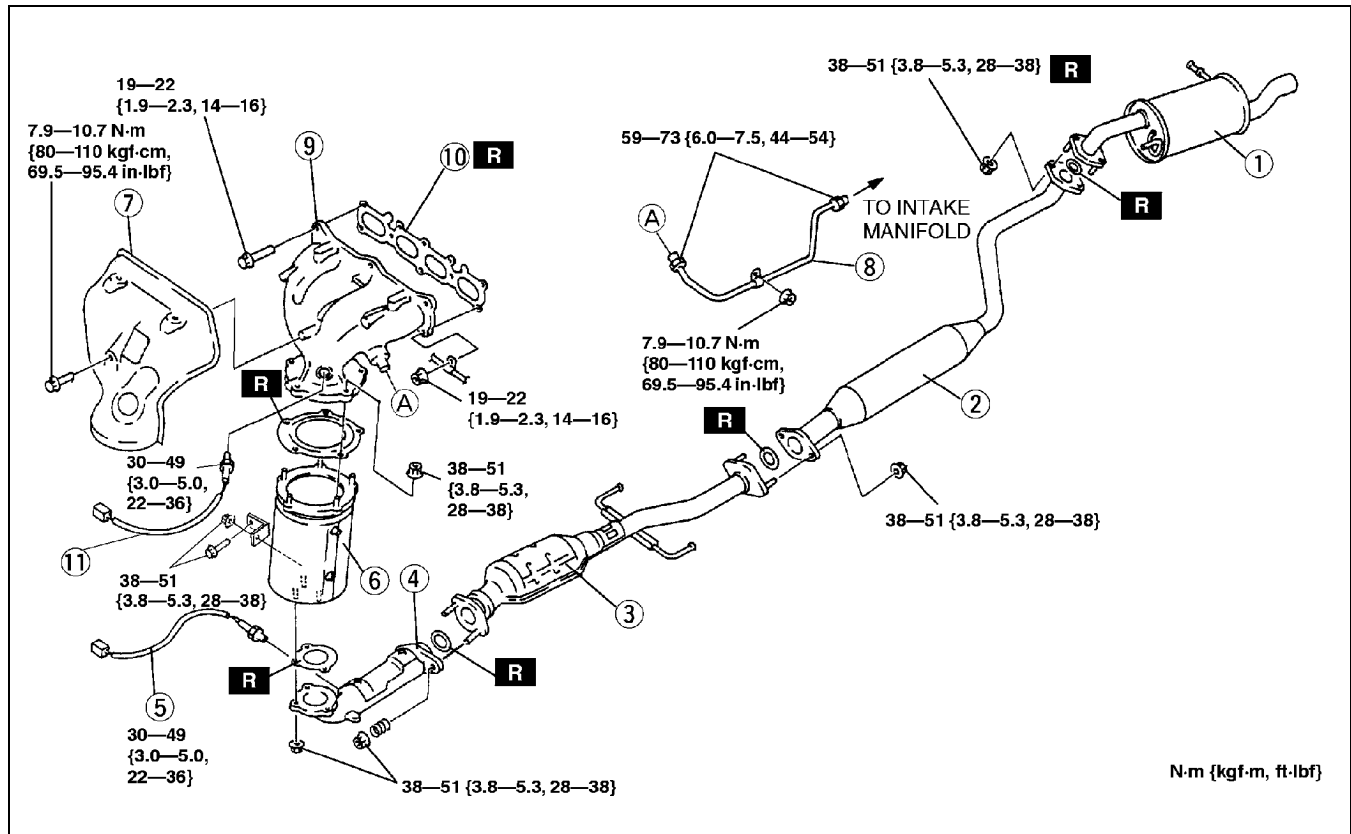

A3U0115W002

# EXHAUST SYSTEM

FS

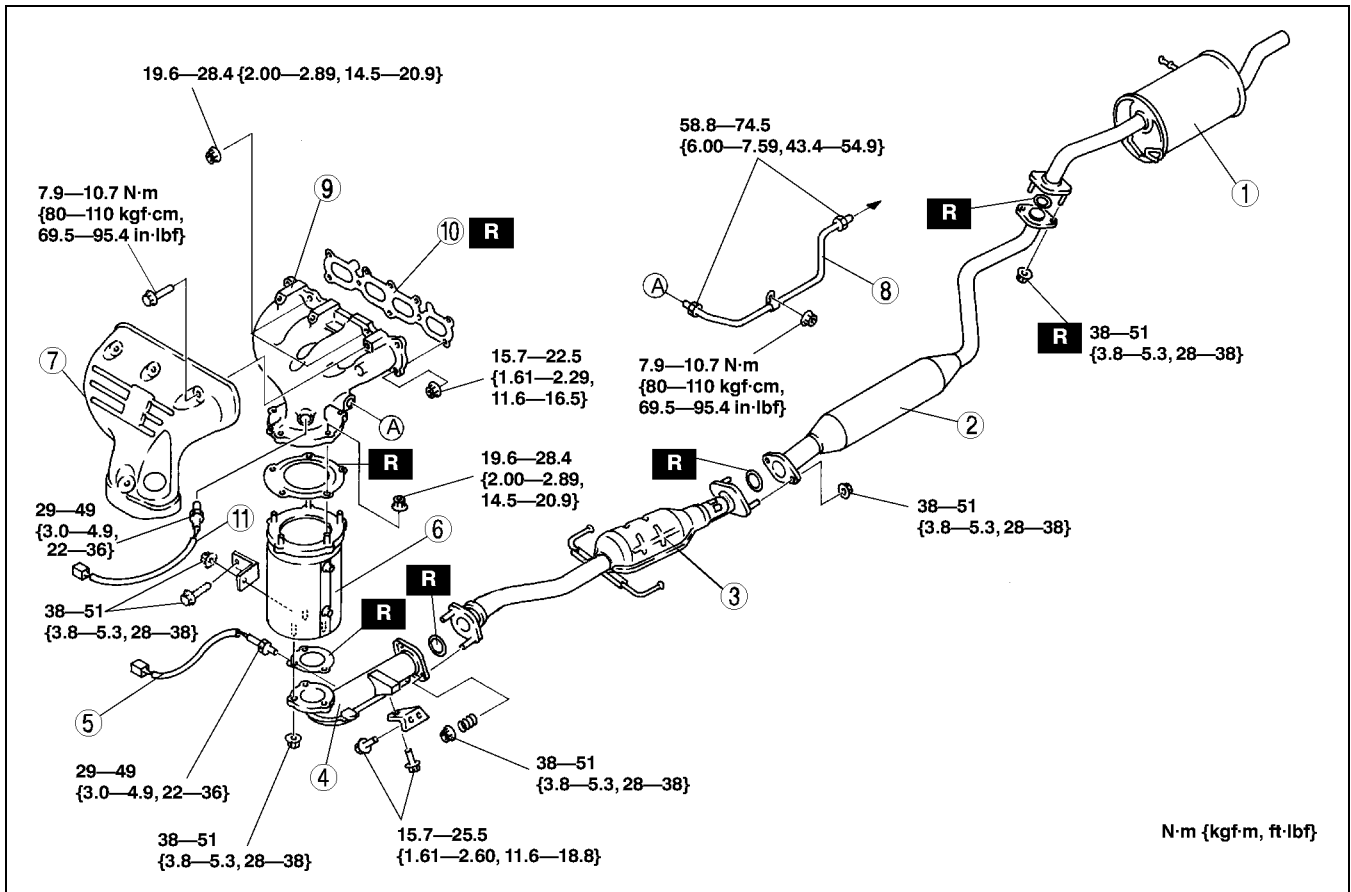

A3U0115W001

1	Main silencer
2	Presilencer
3	TWC
4	Front pipe
5	HO2S (rear)
6	WU-TWC
7	Exhaust manifold insulator

8	EGR pipe
9	Exhaust manifold (See 01-15-2 Exhaust Manifold Removal Note)
10	Exhaust manifold gasket (See 01-15-3 Exhaust Manifold Gasket Installation Note)
11	HO2S (Front)

## Exhaust Manifold Removal Note

1. Remove the air cleaner and air hose.
2. Remove bolt A on the water bypass pipe before removing the exhaust manifold.

## Tightening torque

64—89 N·m {6.5—9.1 kgf·m, 48—65 ft·lbf}

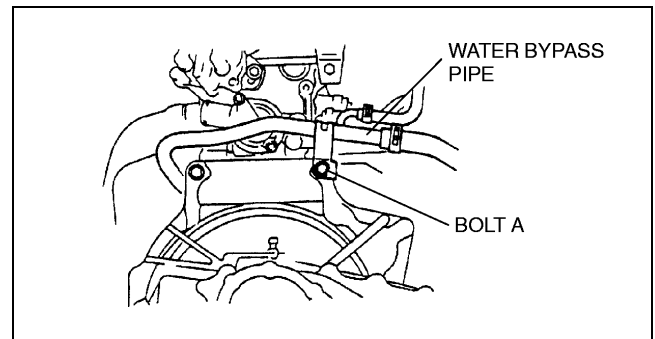

X3U115WA2

## EXHAUST SYSTEM

### Exhaust Manifold Gasket Installation Note

1. To install the exhaust manifold gasket, make sure that the bead side of the gasket is facing the exhaust manifold side.

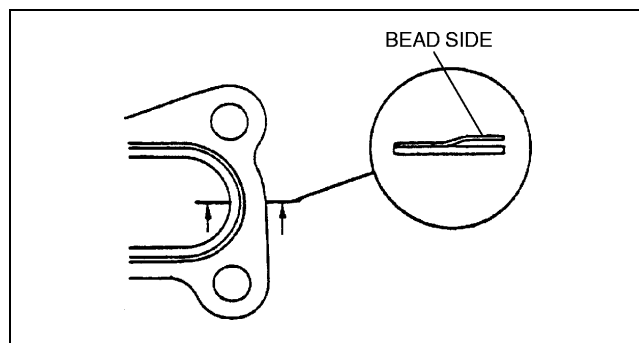

X3U115WA3

01-15

# 01-16 EMISSION SYSTEM

**EMISSION SYSTEM LOCATION**

**INDEX** ..... 01-16-2  
 Evaporative Emission (EVAP) Control System ..... 01-16-2  
 EGR System ..... 01-16-4  
 Positive Crankcase Ventilation (PCV) System ..... 01-16-5  
**EVAPORATIVE EMISSION (EVAP) CONTROL SYSTEM DIAGRAM** ..... 01-16-6  
**EVAPORATIVE EMISSION (EVAP) CONTROL SYSTEM (FUEL TANK SIDE) COMPONENT REMOVAL/INSTALLATION** ..... 01-16-7  
**EVAPORATIVE GAS CHECK VALVE (TWO-WAY) INSPECTION** ..... 01-16-8  
**AIR FILTER INSPECTION** ..... 01-16-9  
**CHARCOAL CANISTER INSPECTION** . 01-16-9  
**CANISTER DRAIN CUT VALVE (CDCV) REMOVAL/INSTALLATION** ..... 01-16-9  
 Evaporative Hose Installation Note ... 01-16-9  
**CANISTER DRAIN CUT VALVE (CDCV) INSPECTION** ..... 01-16-10  
 Simulation Test ..... 01-16-10  
 Airflow Inspection ..... 01-16-10  
 Circuit Open/Short Inspection ..... 01-16-10  
**CATCH TANK INSPECTION** ..... 01-16-11

**PURGE SOLENOID VALVE**

**REMOVAL/INSTALLATION** ..... 01-16-11  
 Vacuum Hose Installation Note ..... 01-16-11  
 Evaporative Hose Installation Note ... 01-16-11  
**PURGE SOLENOID VALVE INSPECTION** ..... 01-16-12  
 Airflow Inspection ..... 01-16-12  
 Circuit Open/Short Inspection ..... 01-16-12  
**FUEL-FILLER CAP INSPECTION** ..... 01-16-13  
 leakage inspection ..... 01-16-13  
**EGR SYSTEM DIAGRAM** ..... 01-16-14  
**EGR VALVE REMOVAL/INSTALLATION** ..... 01-16-15  
**EGR VALVE INSPECTION** ..... 01-16-15  
 Resistance Inspection ..... 01-16-15  
 Circuit Open/Short Inspection ..... 01-16-16  
**EGR BOOST SENSOR SOLENOID VALVE INSPECTION** ..... 01-16-17  
 Airflow Inspection ..... 01-16-17  
 Circuit Open/Short Inspection ..... 01-16-17  
**POSITIVE CRANKCASE VENTILATION (PCV) SYSTEM FLOW DIAGRAM** ..... 01-16-18  
**POSITIVE CRANKCASE VENTILATION (PCV) VALVE INSPECTION** ..... 01-16-18  
**WARM UP THREE-WAY CATALYTIC CONVERTER (WU-TWC) INSPECTION** ..... 01-16-19

**01-16**

# EMISSION SYSTEM

## EMISSION SYSTEM LOCATION INDEX

A3U011601074W01

### Evaporative Emission (EVAP) Control System Engine room side

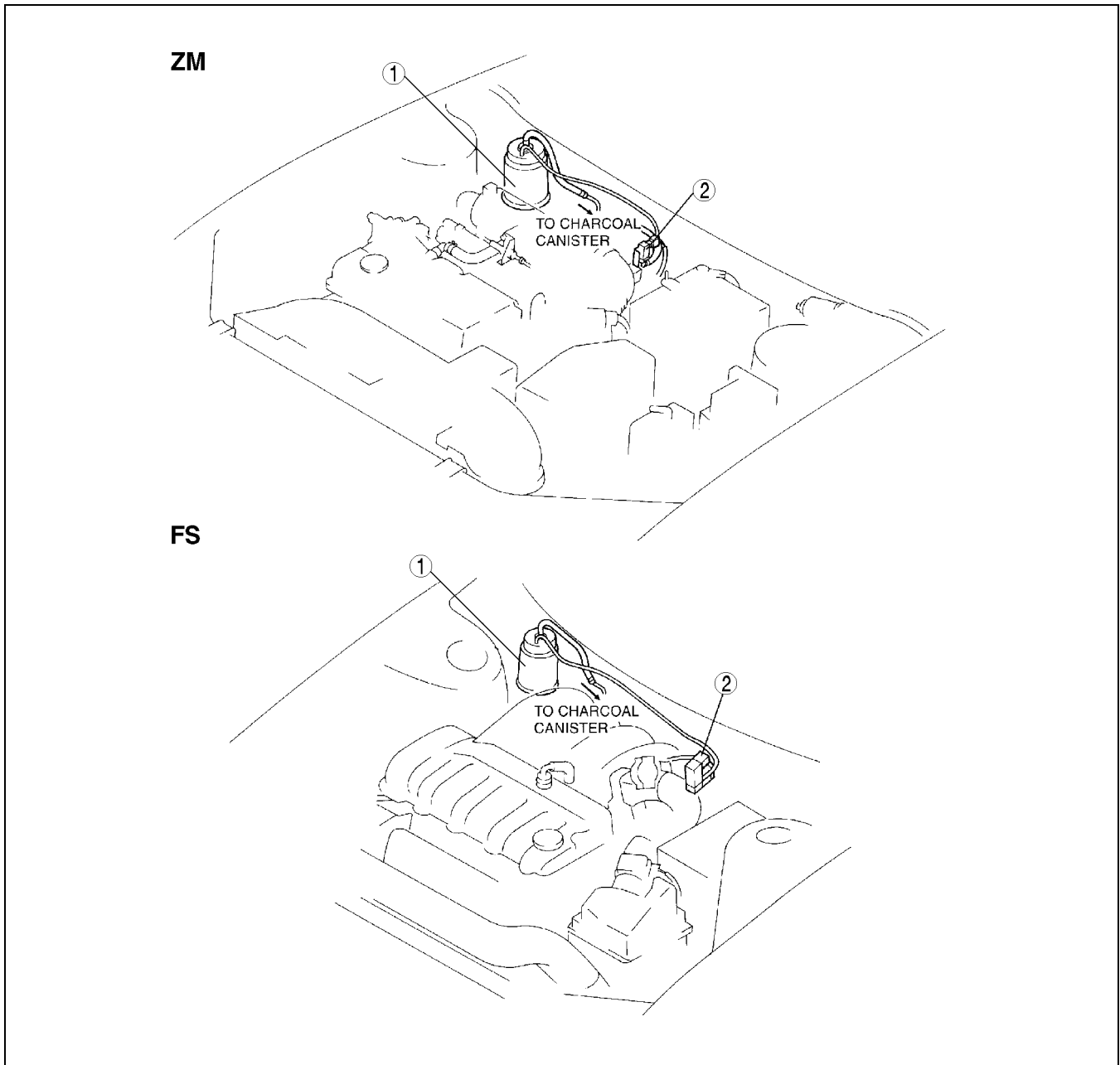

Z3U0116W996

1	Catch tank (See 01-16-11 CATCH TANK INSPECTION)
---	--

2	Purge solenoid valve (See 01-16-11 PURGE SOLENOID VALVE REMOVAL/INSTALLATION) (See 01-16-12 PURGE SOLENOID VALVE INSPECTION)
---	--



# EMISSION SYSTEM

## Fuel tank

01-16

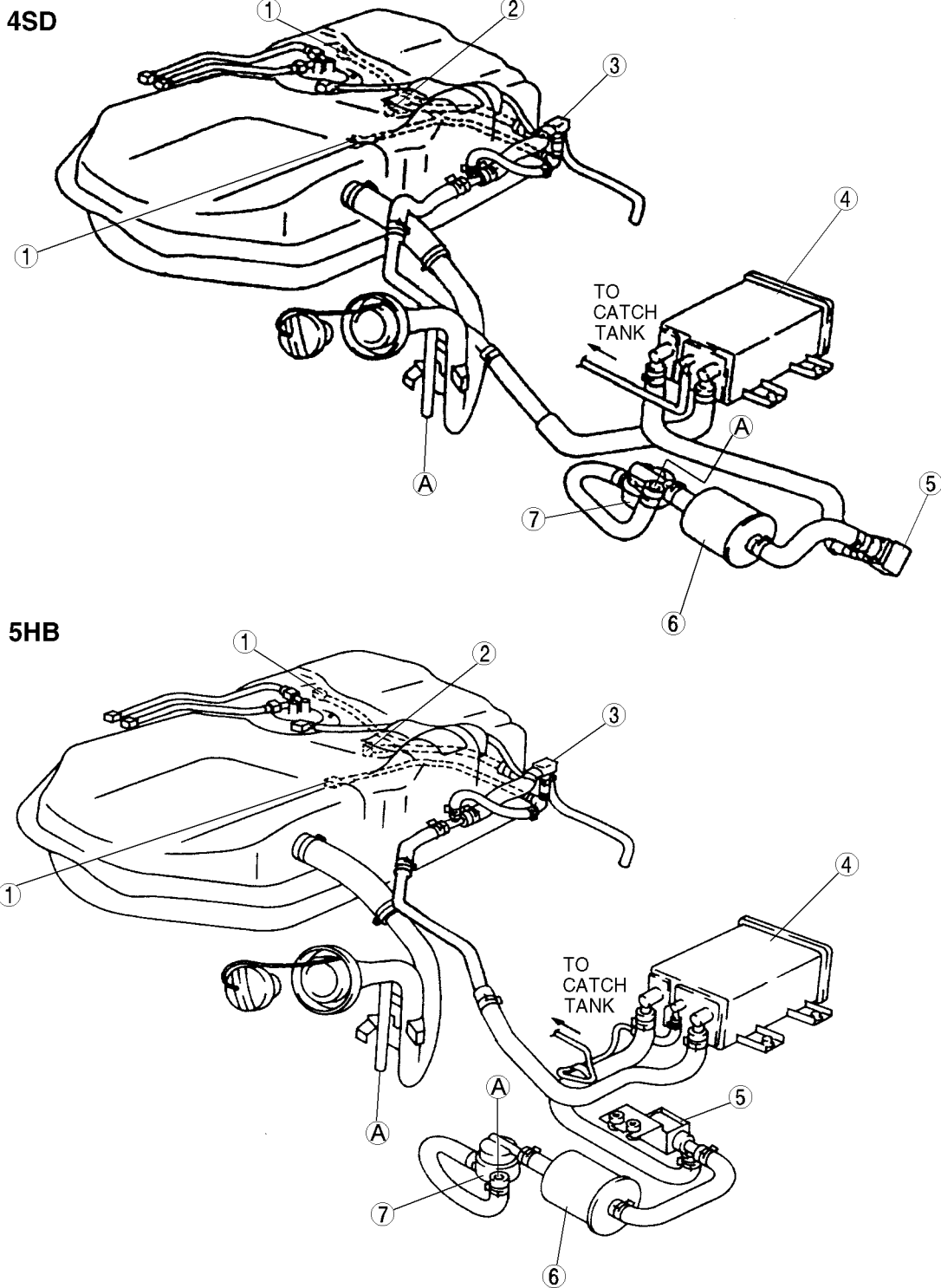

A3U0116W001

1	Rollover valve (See 01-14-13 FUEL TANK INSPECTION)
2	Fuel shut-off valve (See 01-14-13 FUEL TANK INSPECTION)
3	Fuel tank pressure sensor (See 01-40A-40 FUEL TANK PRESSURE SENSOR INSPECTION [ZM]) (See 01-40B-40 FUEL TANK PRESSURE SENSOR INSPECTION [FS])

4	Charcoal canister (See 01-16-9 CHARCOAL CANISTER INSPECTION)
5	Canister drain cut valve (CDCV) (See 01-16-10 CANISTER DRAIN CUT VALVE (CDCV) INSPECTION)
6	Air filter (See 01-16-9 AIR FILTER INSPECTION)

# EMISSION SYSTEM

7	Evaporative gas check valve (two-way) (See 01-16-8 EVAPORATIVE GAS CHECK VALVE (TWO-WAY) INSPECTION)
---	---

## EGR System

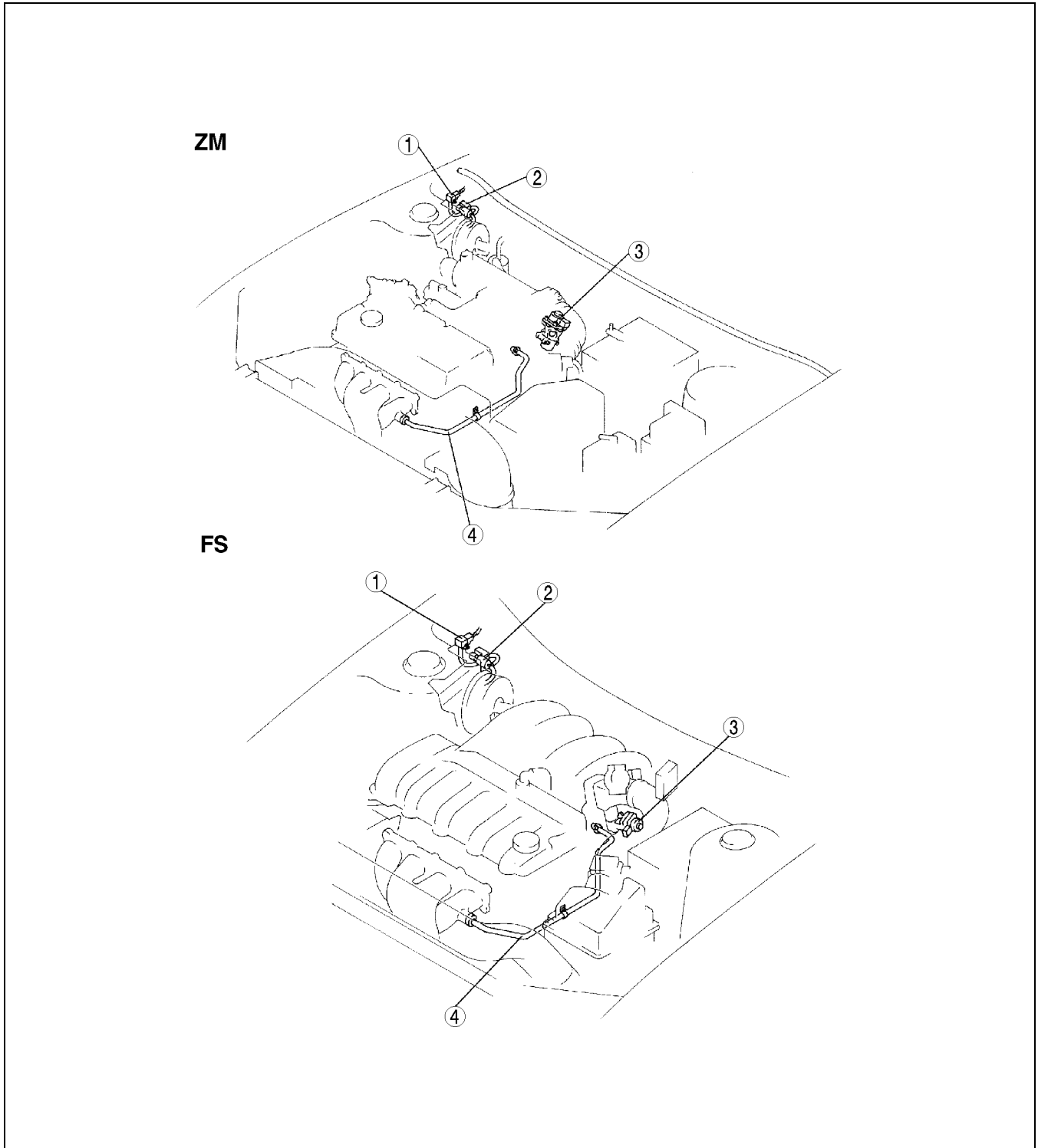

Z3U0116W995

1	EGR boost sensor (See 01-40A-38 EGR BOOST SENSOR INSPECTION [ZM]) (See 01-40B-39 EGR BOOST SENSOR INSPECTION [FS])
---	--

2	EGR boost sensor solenoid valve (See 01-16-17 EGR BOOST SENSOR SOLENOID VALVE INSPECTION)
3	EGR valve (See 01-16-15 EGR VALVE REMOVAL/ INSTALLATION) (See 01-16-15 EGR VALVE INSPECTION)

# EMISSION SYSTEM

4	EGR pipe
---	----------

## Positive Crankcase Ventilation (PCV) System

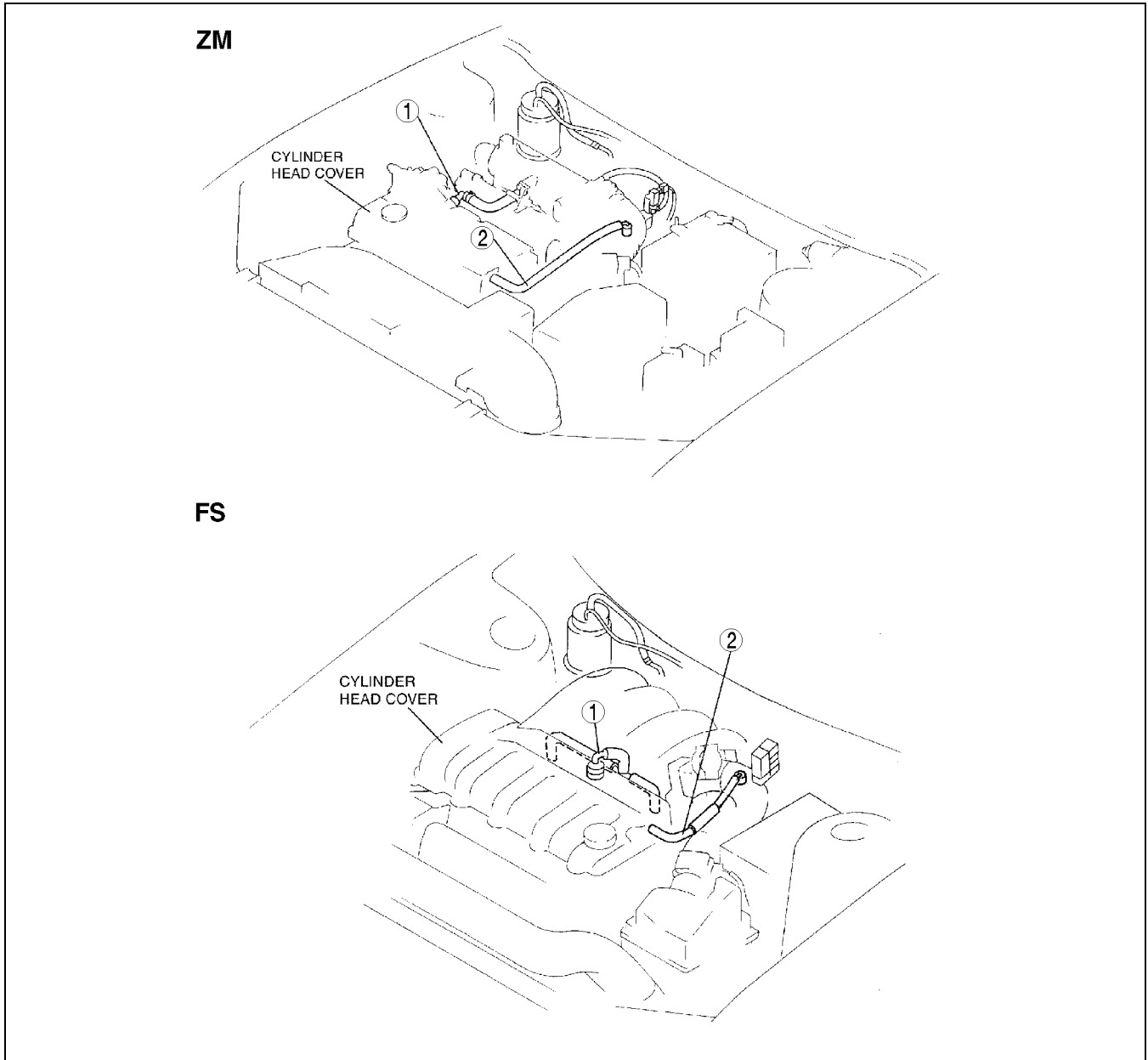

01-16

Z3U0116W994

1	PCV valve (See 01-16-18 POSITIVE CRANKCASE VENTILATION (PCV) VALVE INSPECTION)
---	---

2	Ventilation hose
---	------------------

# EMISSION SYSTEM

## EVAPORATIVE EMISSION (EVAP) CONTROL SYSTEM DIAGRAM

A3U011601074W02

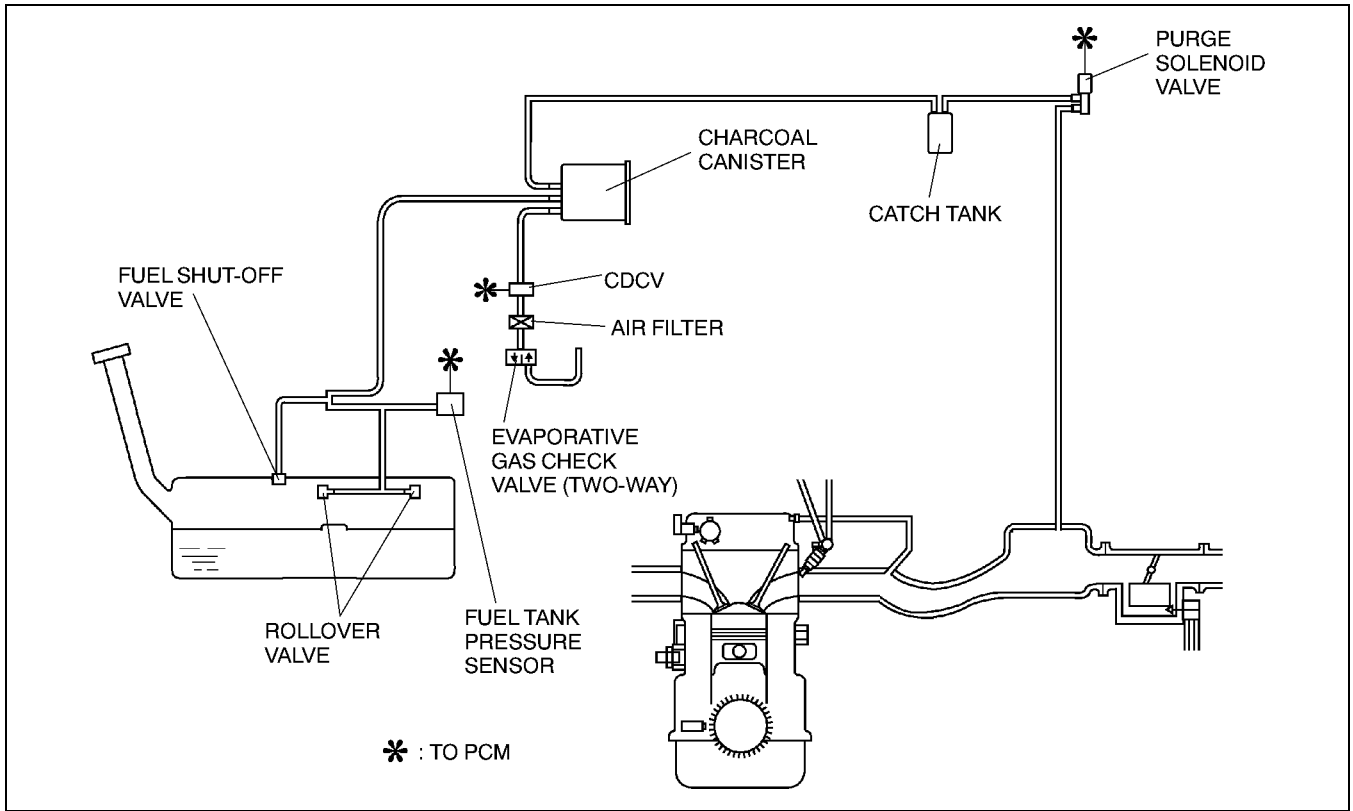

Z3U0116W002

# EMISSION SYSTEM

## EVAPORATIVE EMISSION (EVAP) CONTROL SYSTEM (FUEL TANK SIDE) COMPONENT REMOVAL/INSTALLATION

A3U011601074W03

1. Raise the rear of the vehicle and support it with safety stands.
2. Remove in the order indicated in the table.
3. Install in the reverse order of removal.

4SD

01-16

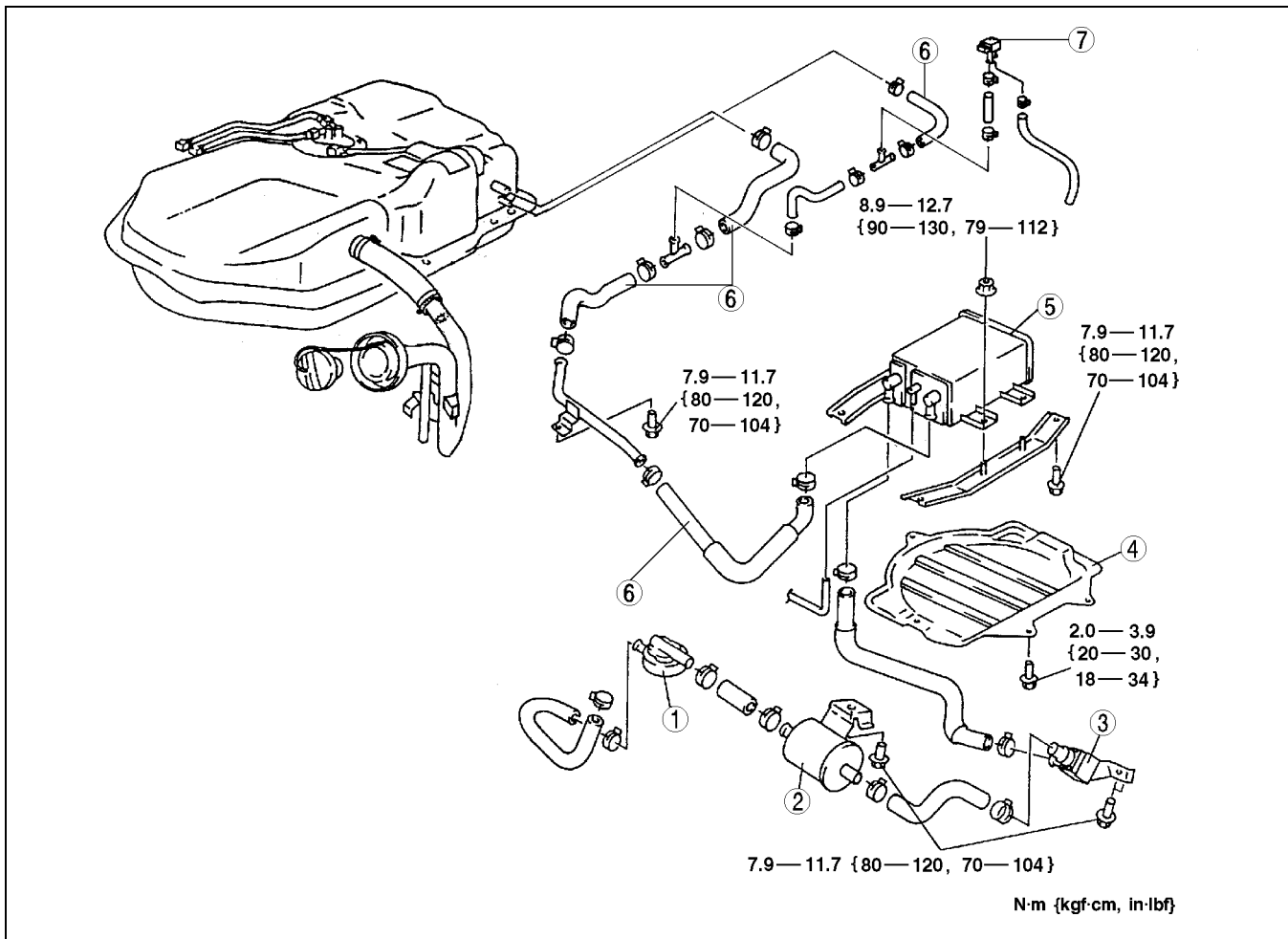

A3U0116W003

1	Evaporative gas check valve (two-way)
2	Air filter
3	CDCV
4	Charcoal canister insulator

5	Charcoal canister
6	Evaporative hose
7	Fuel tank pressure sensor

# EMISSION SYSTEM

5HB

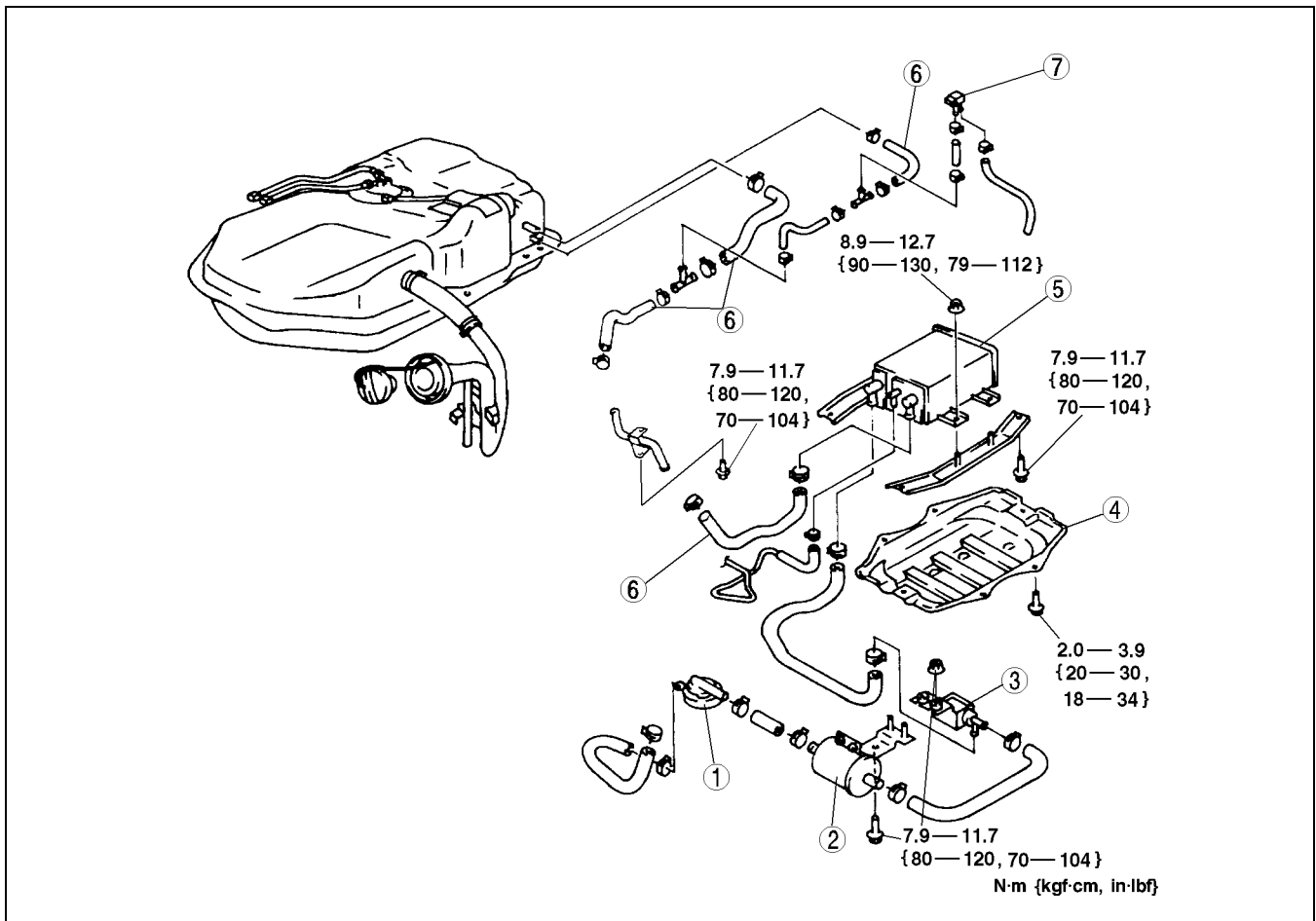

A3U0116W002

1	Evaporative gas check valve (two-way)
2	Air filter
3	CDCV
4	Charcoal canister insulator

5	Charcoal canister
6	Evaporative hose
7	Fuel tank pressure sensor

## EVAPORATIVE GAS CHECK VALVE (TWO-WAY) INSPECTION

A3U011642914W01

- Remove the check valve (two-way).
- Attach an air hose to the **SST**.
- Set the **SST** to port A as shown in the figure.
- Verify that there is airflow from port B when pressure of **+0.99 kPa {+7.4 mmHg, +0.29 inHg}** is applied to port A.
  - If there is no airflow, replace the evaporative gas check valve (two-way).
- Verify that there is airflow from port A when pressure of **+0.99 kPa {+7.4 mmHg, +0.29 inHg}** is applied to port C.
  - If there is no airflow, replace the evaporative gas check valve (two-way).

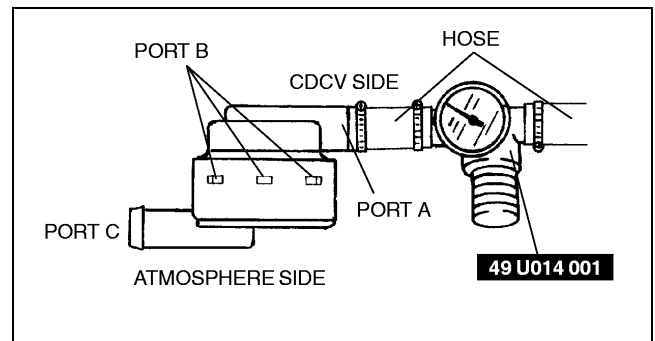

X3U116WB9

# EMISSION SYSTEM

## AIR FILTER INSPECTION

A3U011613988W01

1. Remove the air filter.
2. Blow from port A and verify that there is airflow from port B.
  - If not as specified, replace the air filter.
3. Blow from port B and verify that there is airflow from port A.
  - If not as specified, replace the air filter.

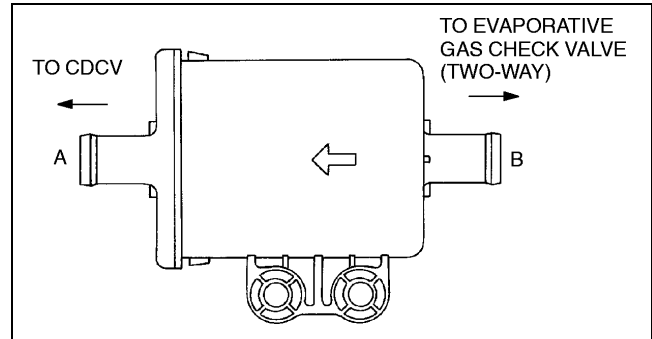

X3U116WA1

01-16

## CHARCOAL CANISTER INSPECTION

A3U011613970W01

### Caution

- Do not apply the pressure more than 20 kPa {0.2 kgf/cm<sup>2</sup>, 2.8 psi} to the charcoal canister, or the charcoal canister will be damaged.

1. Remove the charcoal canister. (See 01-16-7 EVAPORATIVE EMISSION (EVAP) CONTROL SYSTEM (FUEL TANK SIDE) COMPONENT REMOVAL/INSTALLATION.)
2. Plug ports A and C, then blow air into port B.
3. Verify that there is no air leakage from the case.
  - If not as specified, replace the charcoal canister.

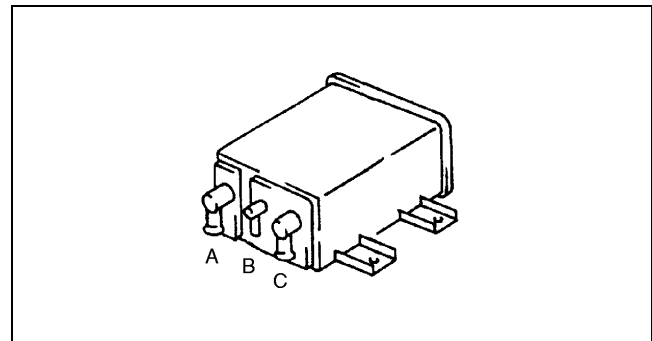

X3U116WA6

## CANISTER DRAIN CUT VALVE (CDCV) REMOVAL/INSTALLATION

A3U011618743W01

1. Disconnect the negative battery cable.
2. Raise the rear of the vehicle and support it with safety stands.
3. Remove in the order indicated in the table.

1	Clamp
2	Evaporative hose (See 01-16-9 Evaporative Hose Installation Note)
3	CDCV

4. Install in the reverse order of removal.

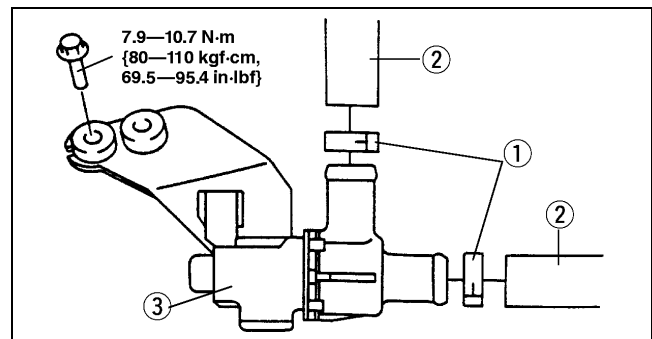

Y3U116WA0

### Evaporative Hose Installation Note

1. Install the evaporative hose until it contacts the stopper.

# EMISSION SYSTEM

## CANISTER DRAIN CUT VALVE (CDCV) INSPECTION

A3U011618743W02

### Simulation Test

- Carry out the "Evaporative Emission Control System Inspection". (See 01-03A-56 Evaporative System Leak Inspection Using Vacuum Pump.) (See 01-03B-55 Evaporative System Leak Inspection Using Vacuum Pump.)
  - If not as specified, perform the following inspection for the CDCV.

### Airflow Inspection

#### Note

- Perform the following test only when directed.
- Disconnect the negative battery cable.
  - Remove the CDCV. (See 01-16-9 CANISTER DRAIN CUT VALVE (CDCV) REMOVAL/INSTALLATION.)
  - Inspect airflow between the ports under the following conditions.
    - If not as specified, replace the CDCV.
    - If as specified but the "Simulation Test" is failed, inspect evaporative hoses for improper routing, kinks or leakage, and carry out the "Circuit Open/Short Inspection" and repair or replace the parts if necessary.

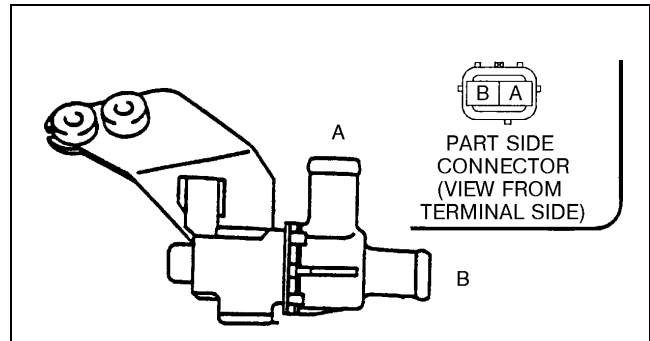

Y3U116WA1

○—○ : Continuity ○—○ : Airflow

Step	Terminal		Port	
	A	B	A	B
1	○—○	○—○	○—○	○—○
2	B+	GND		

X3U116WCA

### Circuit Open/Short Inspection

- Remove the PCM.
- Connect the **SST** (104 Pin Breakout Box) to the PCM as shown.
- Tighten the connector attaching screw.

#### Tightening torque

7.9—10.7 N·m {80—110 kgf·cm, 69.5—95.4 in·lbf}

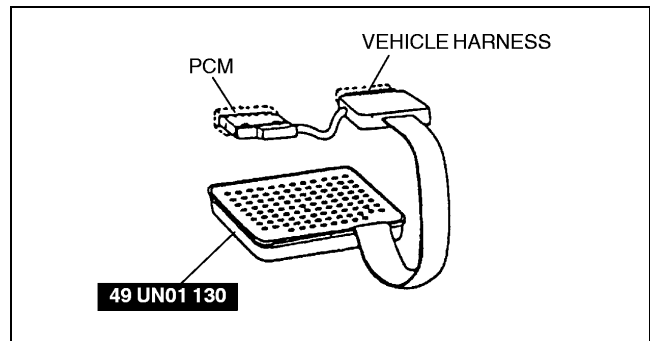

Y3U116WAG



# EMISSION SYSTEM

- Inspect for an open or short circuit in the following wiring harnesses by probing the applicable sensor and **SST** (104 Pin Breakout Box) terminals with ohmmeter leads.

### Open circuit

- GND circuit (CDCV connector terminal B and PCM connector terminal 18 through common connector)
- Power circuit (CDCV connector terminal A and main relay connector terminal D)

### Short circuit

- GND circuit (CDCV connector terminal B and PCM connector terminal 18 through common connector to GND)
- Power circuit (CDCV connector terminal A and main relay connector terminal D to GND)

- Install the CDCV.

- Connect the negative battery cable.

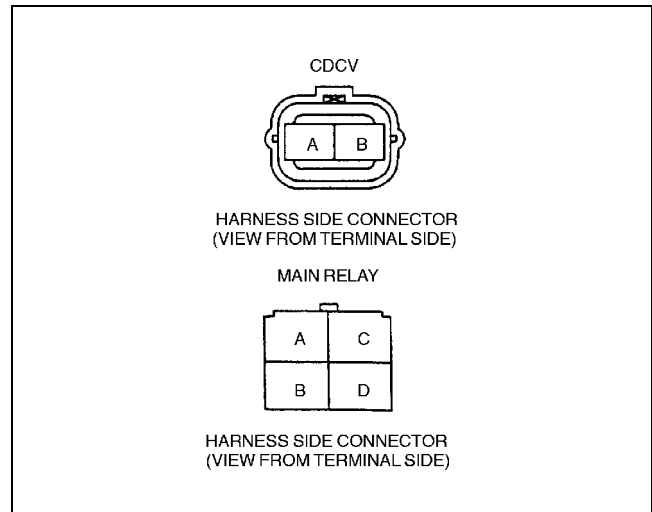

Z3U0116W997

01-16

## CATCH TANK INSPECTION

- Remove the catch tank.
- Plug the purge solenoid valve side port of the catch tank.
- Blow from the charcoal canister side port and verify that there is no air leakage from the case.
  - If not as specified, replace the catch tank.

A3U011613978W01

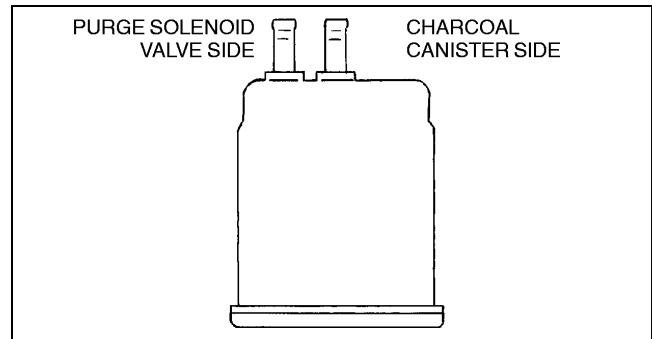

X3U116WB0

## PURGE SOLENOID VALVE REMOVAL/INSTALLATION

- Disconnect the negative battery cable.
- Remove in the order indicated in the table.

1	Evaporative hose (See 01-16-11 Evaporative Hose Installation Note)
2	Vacuum hose (See 01-16-11 Vacuum Hose Installation Note)
3	Purge solenoid valve

A3U011618740W01

- Install in the reverse order of removal.

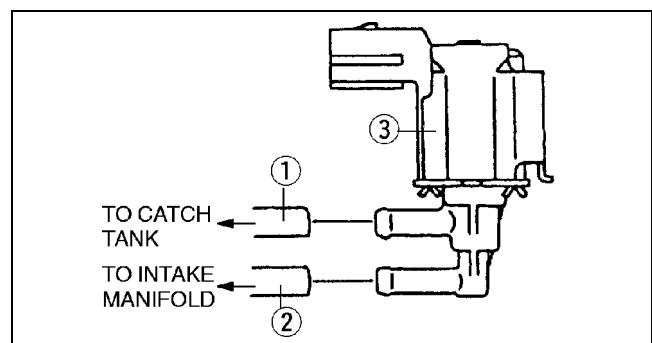

Z3U0116W993

### Vacuum Hose Installation Note

- Install the vacuum hose until it contacts the stopper.

### Evaporative Hose Installation Note

- Attach the evaporative hose until it contacts the stopper.

# EMISSION SYSTEM

## PURGE SOLENOID VALVE INSPECTION

A3U011618740W02

### Airflow Inspection

#### Note

- Perform the following test only when directed.

1. Remove the purge solenoid valve. (See 01-16-11 PURGE SOLENOID VALVE REMOVAL/INSTALLATION.)
2. Inspect airflow between the ports under the following conditions.
  - If not as specified, replace the purge solenoid valve.
  - If as specified, inspect the vacuum hoses for improper routing, kinks or leakage, and carry out the "Circuit Open/Short Inspection" and repair or replace the parts if necessary.

○—○ : Continuity    ○—○ : Airflow

Step	Terminal		Port	
	A	B	A	B
1	○—○	○—○		
2	B+	GND	○—○	○—○

X3U116WC1

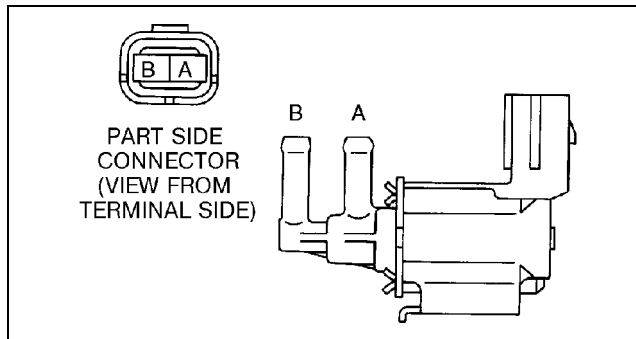

Z3U0116W992

### Circuit Open/Short Inspection

1. Remove the PCM.
2. Connect the **SST** (104 Pin Breakout Box) to the PCM as shown.
3. Tighten the connector attaching screw.

#### Tightening torque

7.9—10.7 N·m {80—110 kgf·cm, 69.5—95.4 in·lbf}

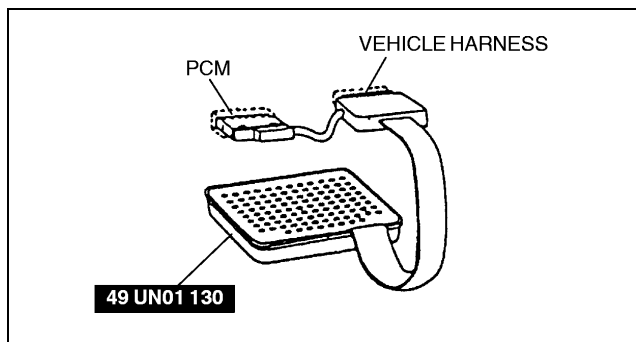

Y3U116WAJ

4. Inspect for an open or short circuit in the following wiring harnesses by probing the applicable sensor and **SST** (104 Pin Breakout Box) terminals with ohmmeter leads.

#### Open circuit

- Power circuit (purge solenoid valve connector terminal A and main relay connector terminal D through common connector)
- Control circuit (purge solenoid valve connector terminal B and PCM connector terminal 67 through common connector)

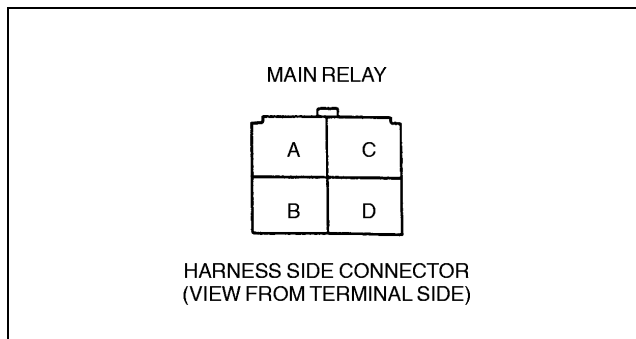

X3U116WC0

## Short circuit

- Power circuit (purge solenoid valve connector terminal A and main relay connector terminal D through common connector to GND)
  - Control circuit (purge solenoid valve connector terminal B and PCM connector terminal 67 through common connector to GND)
5. Install the purge solenoid valve.
  6. Connect the negative battery cable.

## FUEL-FILLER CAP INSPECTION

A3U011642250W01

01-16

### leakage inspection

1. Perform the following **SST** (Evaporative Emission System Tester MZ254AT3641) self-test.

#### Note

- If the tester does not work correctly during self-test, see the tester operators manual for more detailed procedures.

- (1) Verify the gas cylinder valve is closed and the control valve located on the tester is in the TEST position. All tester display should be off at this time.
- (2) Connect the long hose (part of **SST**) to the tester.
- (3) Connect the manifold assembly (part of **SST**) to the long hose as shown.
- (4) Open the gas cylinder valve and verify the gas cylinder regulator left gauge reads **10 to 12 psi** (preset at factory).
  - If not, see the tester operators manual to contact tester manufacturer.
- (5) Press the ON/OFF switch to turn on the **SST** and make sure the left display reads 0.0.
- (6) Turn the control valve on the tester to the FILL position.
- (7) Verify the left display reading is **within 13.9 to 14.0 inches** of water.
  - If not, adjust the pressure using the regulator knob located on the right side of the tester.
- (8) Turn the control valve to TEST position and press the START switch.
- (9) After the **2-minute** countdown (left display) is completed, the right display shows the total pressure loss for that period. A **0.5 inch** of water loss is acceptable on the self-test.
  - If the loss is **more than 0.5 inch** of water, perform one or more self-test. If the failed test repeats, check for leak using the ultrasonic leak detector (part of **SST**).

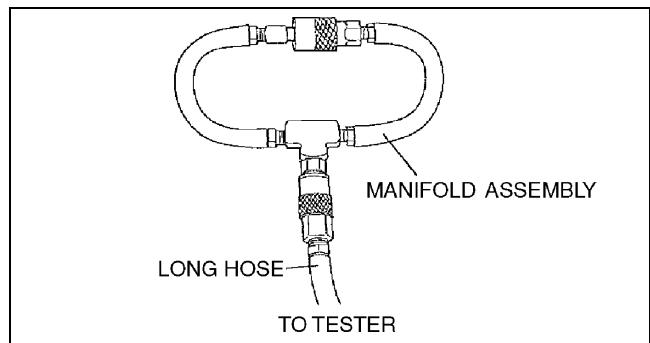

YMU116WZ1

2. Press the RESET switch to set the left display reading to 0.0.
3. Connect the fuel cap receiver assembly (part of **SST**) to the manifold assembly and fuel-filler cap from the vehicle.

- If the fuel-filler cap is not a genuine part, replace it.

4. Turn the control valve to the FILL position.
5. Wait (**maximum 20 s**) until the left display reads **13.9 to 14 inches** of water.
  - If the reading is slightly below, adjust it using the regulator knob.
  - If the reading is far below, the fuel-filler cap has leak. Replace it.
6. Turn the control valve to the TEST position and press the START switch.
7. After the **2-minute** countdown (left display) is completed, check the test result (the failed/ passed light on the tester).

- If the green light turns on, the fuel-filler cap is OK.
- If the red light turns on, the fuel-filler cap has leakage. Replace it.

8. Close the gas cylinder valve.
9. Turn the control valve to the FILL position.
10. Press the ON/OFF switch to turn off the tester.

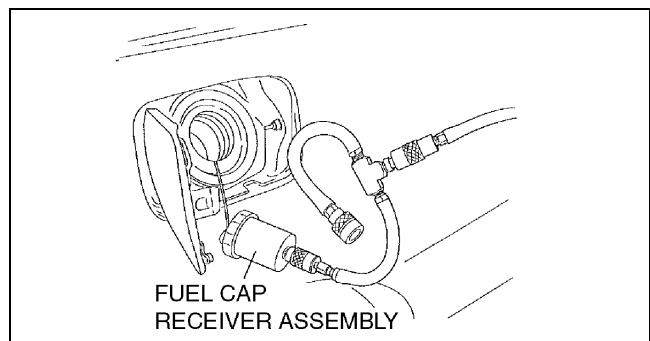

YMU116WZ2

# EMISSION SYSTEM

## EGR SYSTEM DIAGRAM

A3U01162000W01

ZM

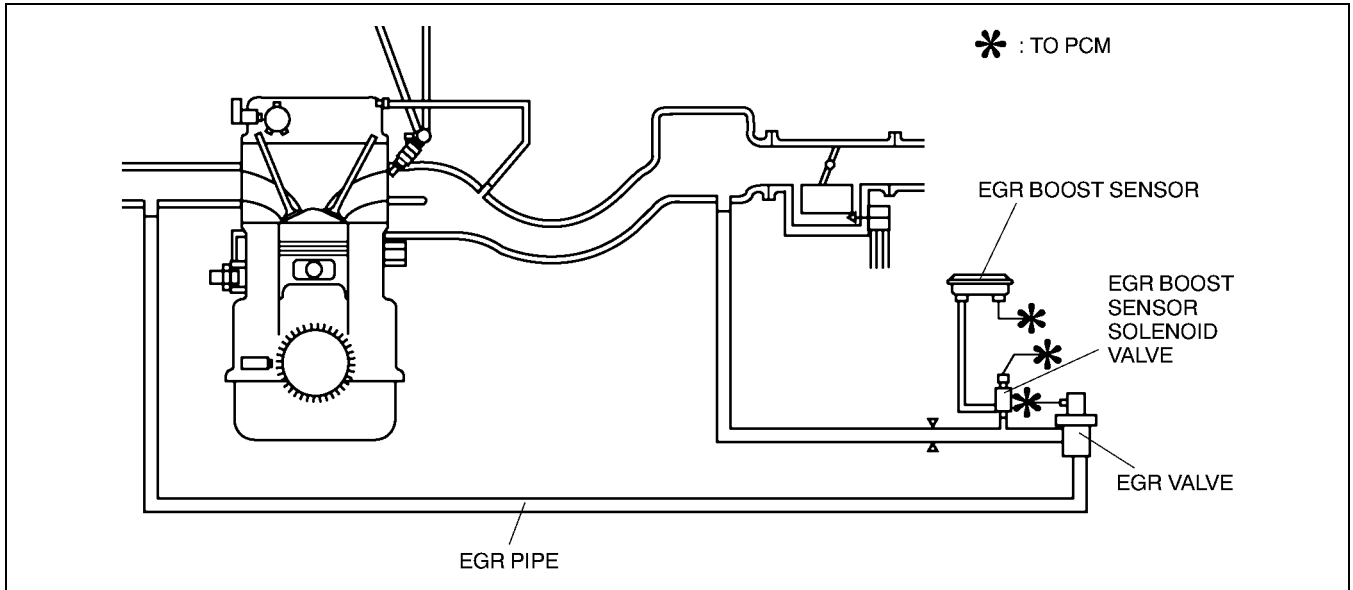

Z3U0116W004

FS

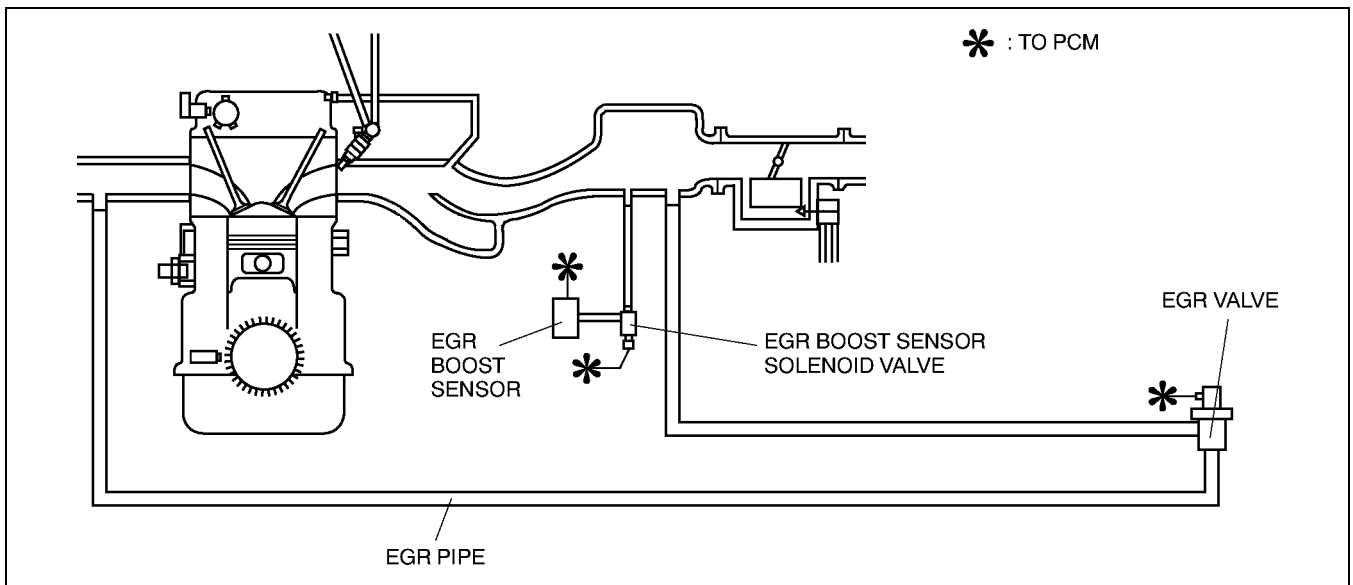

Z3U0116W005

# EMISSION SYSTEM

## EGR VALVE REMOVAL/INSTALLATION

A3U011620300W01

1. Disconnect the negative battery cable.
2. Remove in the order indicated in the table.
3. Install in the reverse order of removal.

1	EGR valve connector
2	EGR valve

4. Connect the negative battery cable.

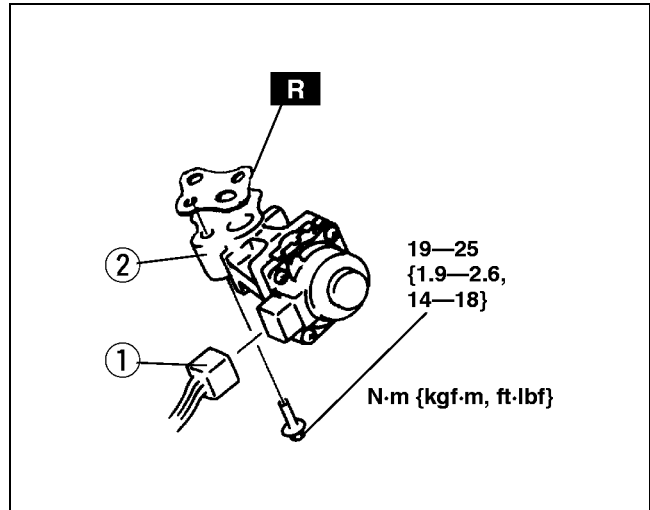

Z3U0116W007

01-16

## EGR VALVE INSPECTION

### Resistance Inspection

A3U011620300W02

#### Note

- Perform the following test only when directed.

1. Disconnect the negative battery cable.
2. Inspect resistance of the EGR valve coils.
  - If not as specified, replace the EGR valve.
  - If as specified, inspect the vacuum hoses for improper routing, kinks or leakage, and carry out the "Circuit Open/Short Inspection" and repair or replace the parts if necessary.

Terminals	Resistance (ohm)
C—E	20—24
C—A	
D—B	
D—F	

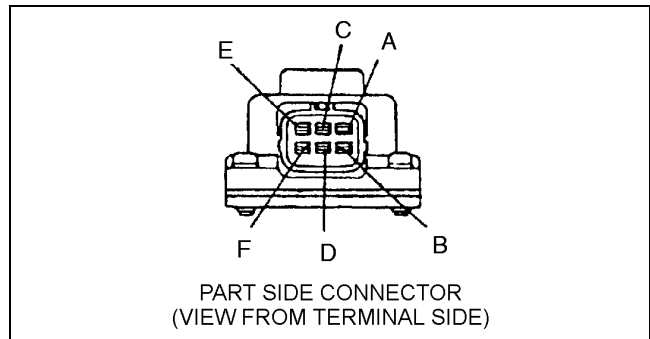

Y3U116WA8

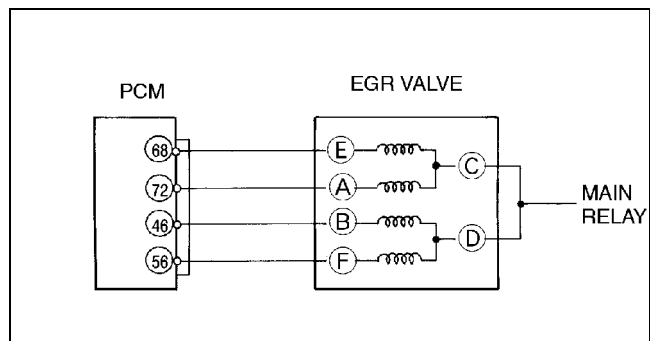

X3U116WB4

# EMISSION SYSTEM

## Circuit Open/Short Inspection

1. Remove the PCM.
2. Connect the **SST** (104 Pin Breakout Box) to the PCM as shown.
3. Tighten the connector attaching screw.

### Tightening torque

7.9—10.7 N·m {80—110 kgf·cm, 69.5—95.4 in·lbf}

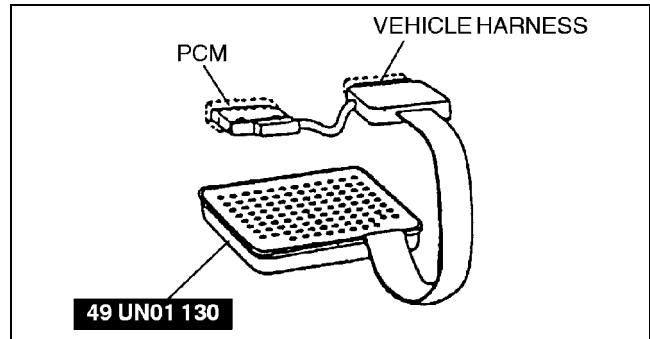

Y3U116WAK

4. Inspect for an open or short circuit in the following wiring harnesses by probing the applicable sensor and **SST** (104 Pin Breakout Box) terminals with ohmmeter leads.

### Open circuit

- Control circuit (EGR valve connector terminal E and PCM connector terminal 68)
- Control circuit (EGR valve connector terminal A and PCM connector terminal 72)
- Control circuit (EGR valve connector terminal B and PCM connector terminal 46)
- Control circuit (EGR valve connector terminal F and PCM connector terminal 56)
- Power circuit (EGR valve connector terminal C or D and main relay connector terminal D through common connector)

### Short circuit

- Control circuit (EGR valve connector terminal E and PCM connector terminal 68 to GND)
- Control circuit (EGR valve connector terminal A and PCM connector terminal 72 to GND)
- Control circuit (EGR valve connector terminal B and PCM connector terminal 46 to GND)
- Control circuit (EGR valve connector terminal F and PCM connector terminal 56 to GND)
- Power circuit (EGR valve connector terminal C or D and main relay connector terminal D through common connector to GND)

5. Remove the EGR valve, and inspect for any damage or clogging. Replace the EGR valve if not as specified.
6. Connect the negative battery cable.

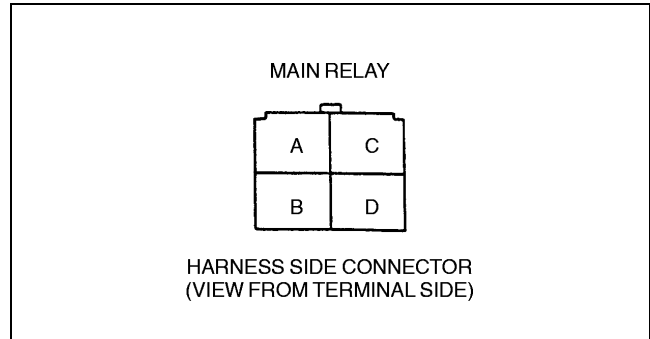

X3U116WB5

## EGR BOOST SENSOR SOLENOID VALVE INSPECTION

A3U011618744W01

### Airflow Inspection

#### Note

- Perform the following test only when directed.

- Disconnect the negative battery cable.
- Remove the EGR boost sensor solenoid valve.
- Inspect airflow between each port under the following conditions.
  - If not as specified, replace the EGR boost sensor solenoid valve.
  - If as specified, inspect the vacuum hoses for improper routing, kinks or leakage, and carry out the "Circuit Open/Short Inspection" and repair or replace the parts if necessary.

○—○ : Continuity    ○=○ : Airflow

Step	Terminal		Port		
	A	B	A	B	C
1	○—○	○—○		○=○	○=○
2	B+	GND	○=○		

X3U116WCB

- Connect the negative battery cable.

### Circuit Open/Short Inspection

- Remove the PCM.
- Connect the **SST** (104 Pin Breakout Box) to the PCM as shown.
- Tighten the connector attaching screw.

#### Tightening torque

**7.9—10.7 N·m {80—110 kgf·cm, 69.5—95.4 in·lbf}**

- Inspect for an open or short circuit in the following wiring harnesses by probing the applicable sensor and **SST** (104 Pin Breakout Box) terminals with ohmmeter leads.

#### Open circuit

- Power circuit (EGR boost sensor solenoid valve connector terminal A and main relay connector terminal D through common connector)
- Control circuit (EGR boost sensor solenoid valve connector terminal B and PCM connector terminal 98)

#### Short circuit

- Power circuit (EGR boost sensor solenoid valve connector terminal A and main relay connector terminal D through common connector to GND)
- Control circuit (EGR boost sensor solenoid valve connector terminal B and PCM connector terminal 98 to GND)

- Install the EGR boost sensor solenoid valve.
- Connect the negative battery cable.

01-16

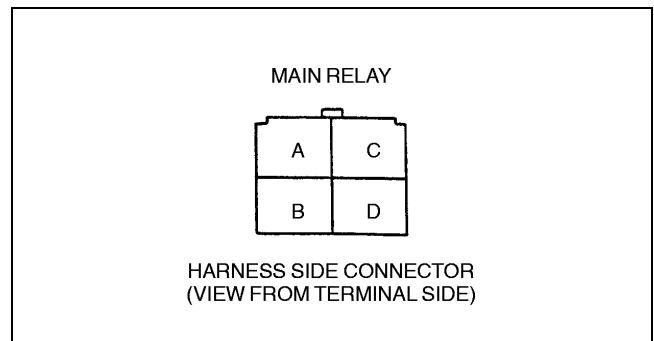
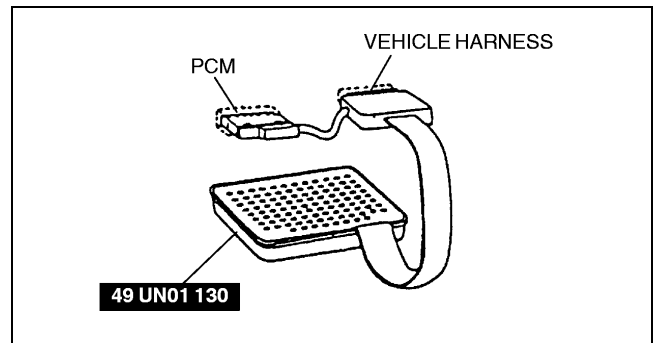
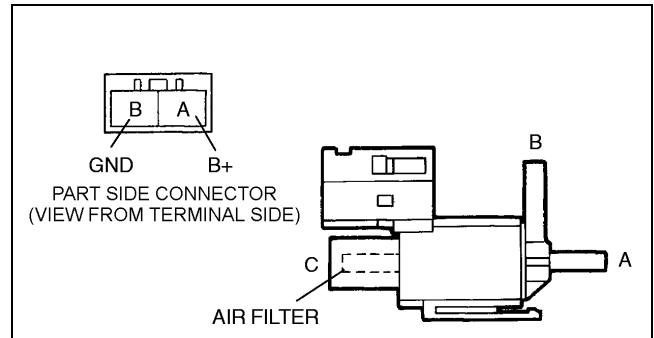

# EMISSION SYSTEM

## POSITIVE CRANKCASE VENTILATION (PCV) SYSTEM FLOW DIAGRAM

A3U011613890W01

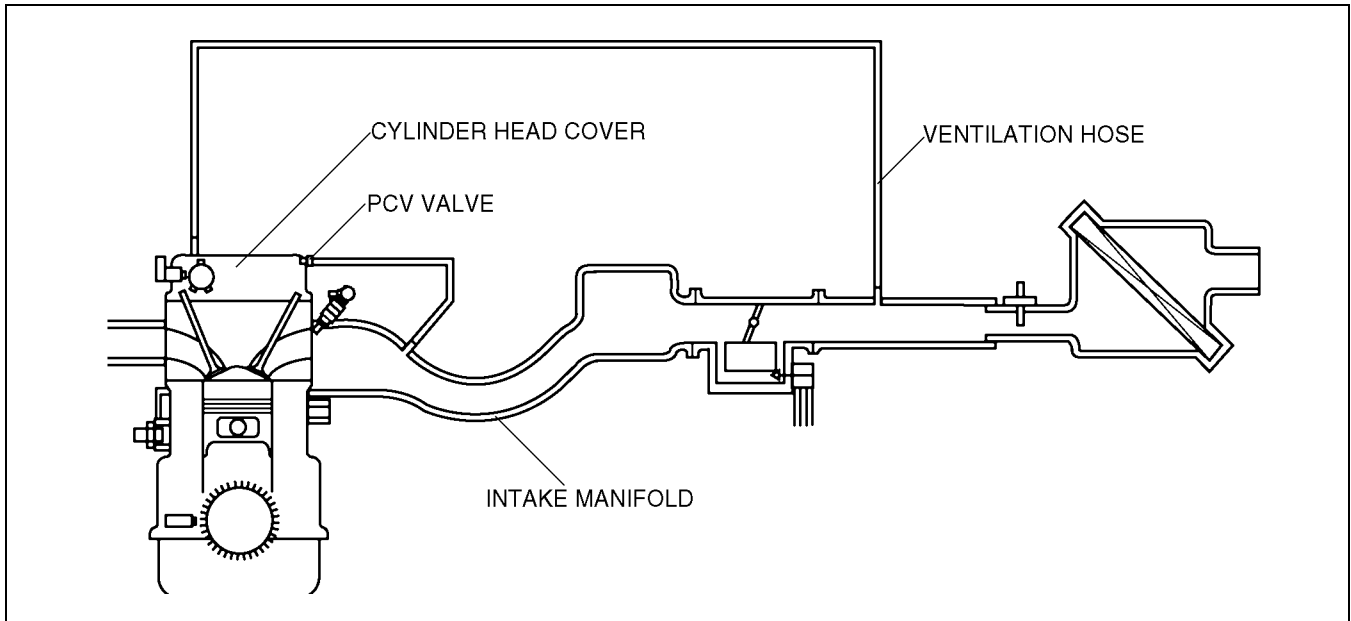

Z3U0116W006

## POSITIVE CRANKCASE VENTILATION (PCV) VALVE INSPECTION

A3U011613890W02

1. Remove the PCV valve.
2. Blow through the valve and verify that air flows as specified.
  - If not as specified, replace the PCV valve.

### Specification

Condition	Airflow
Air applied from port A	Yes
Air applied from port B	No

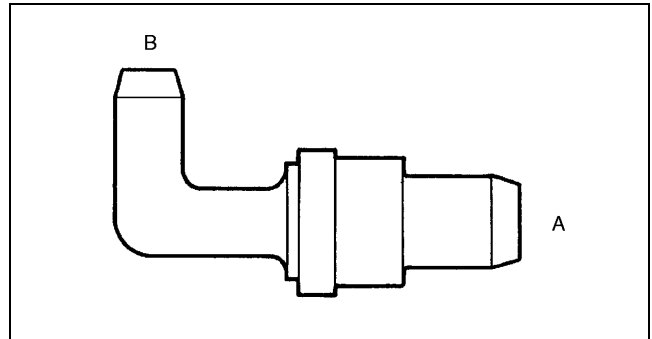

X3U116WB8



# EMISSION SYSTEM

## WARM UP THREE-WAY CATALYTIC CONVERTER (WU-TWC) INSPECTION

A3U011620505W01

### Note

- Make sure that no HO2S DTC has been detected. If detected, this inspection cannot be used for WU-TWC inspection.

1. Connect the WDS or equivalent and monitor PIDs as following.
  - Monitor the WU-TWC using O2S11 PID for upstream HO2S and O2S12 PID for downstream HO2S.
2. Begin to monitor the appropriate PIDs.
3. Drive the vehicle for **10 min** at **65—96 km/h {40—60 mph}** to ensure the WU-TWC reaches operating temperature.
4. Stop the vehicle and leave in a safe place.
5. Let the engine at idle.
6. Record PIDs for **1 min**.
7. Select the appropriate PIDs and read the graph.
8. Count the number of times (inversions) that the upstream HO2S graph line actually crosses the **0.5 V** line.
9. Count the number of times (inversions) that the downstream HO2S graph line actually crosses the **0.5 V** line.

01-16

### Note

- Do not count the number of peaks. Refer to the illustration.

10. Using the following equation, calculate the value of ratio.

### Equation

$$\text{RATIO} = \text{Upstream HO2S inversion} + \text{downstream HO2S inversion}$$

- If the ratio is **2** or more or no downstream HO2S inversion, the WU-TWC is functioning properly.
- If the ratio is less than **2**, the WU-TWC is not functioning properly. Replace the WU-TWC.

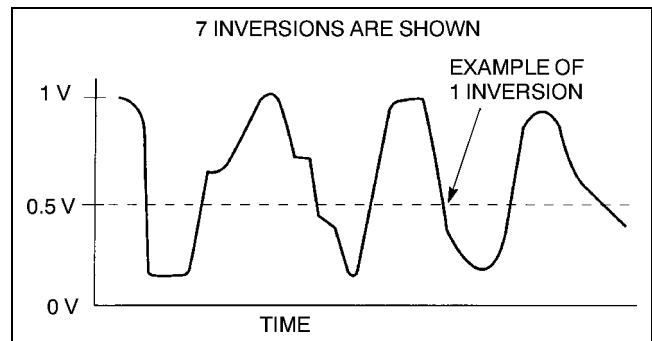

Z3U0116W011

### Upstream HO2S graphline example

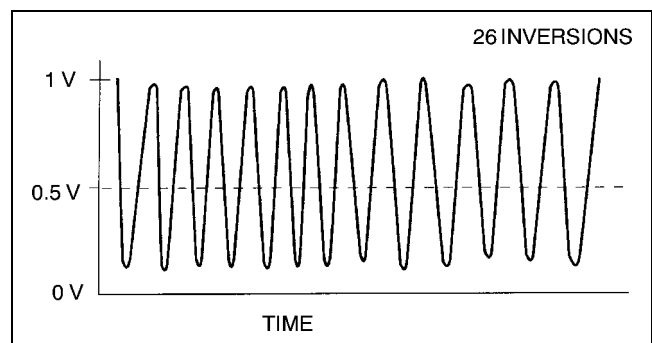

Y3U116WAA

# EMISSION SYSTEM

## Downstream HO2S graphline example 1

### Equation

$\text{RATIO} = 26 \text{ inversions (upstream HO2S inversions)} + 7 \text{ inversions (downstream HO2S inversions)} = 3.7 \text{ (good WU-TWC)}$

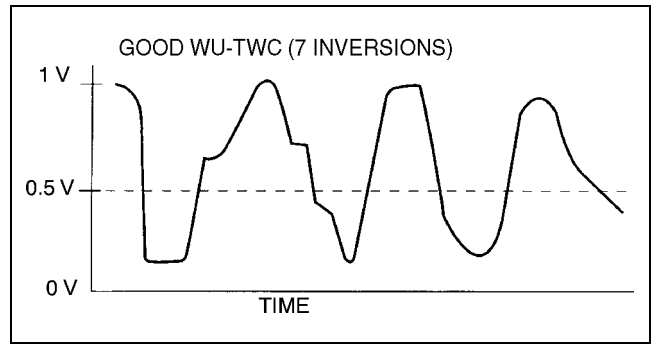

## Downstream HO2S graphline example 2

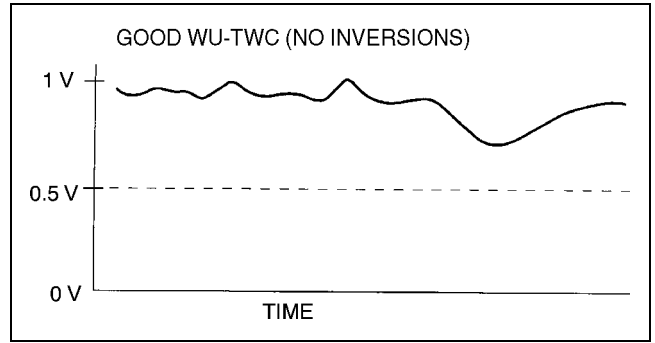

## Downstream HO2S graphline example 3

### Equation

$\text{RATIO} = 26 \text{ inversions (upper stream HO2S inversions)} \div 19 \text{ inversions (downstream HO2S inversions)} = 1.4 \text{ (deteriorated WU-TWC)}$

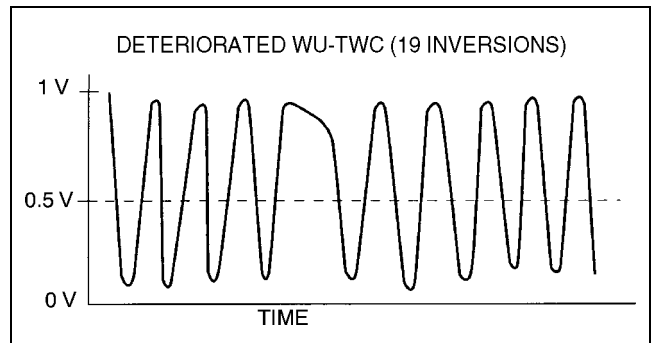

# 01-17 CHARGING SYSTEM

**BATTERY REMOVAL/INSTALLATION . 01-17-1**  
**BATTERY INSPECTION . . . . . 01-17-1**  
 Battery . . . . . 01-17-1  
 Back-up Current. . . . . 01-17-2  
**BATTERY RECHARGING. . . . . 01-17-2**

**GENERATOR**  
**REMOVAL/INSTALLATION. . . . . 01-17-3**  
 Drive Belt Installation Note . . . . . 01-17-3  
**GENERATOR INSPECTION . . . . . 01-17-3**  
 Generator Warning Light. . . . . 01-17-3  
 Generator . . . . . 01-17-4  
 Current . . . . . 01-17-4

## BATTERY REMOVAL/INSTALLATION

1. Remove in the order indicated in the table.

1	Negative battery cable
2	Positive battery cable
3	Battery clamp
4	Battery box
5	Battery
6	Battery tray

2. Install in the reverse order of removal.

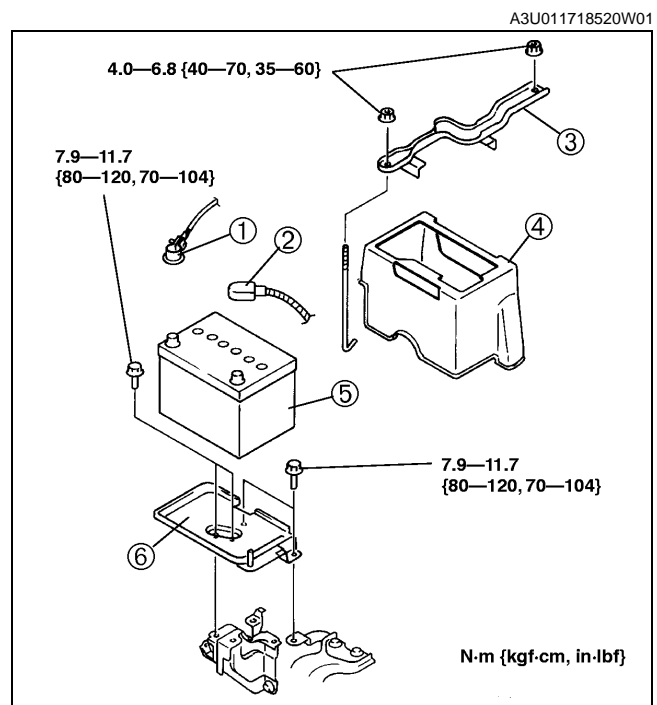

## BATTERY INSPECTION

### Battery

- Inspect the battery in the following procedure.

Step	Inspection		Action
1	Measure open circuit voltage of battery.	Above 12.4 V	Go to step 3.
		Below 12.4 V	Go to next step.
2	Quick charge for <b>30 minutes</b> and recheck voltage.	Above 12.4 V	Go to next step.
		Below 12.4 V	Replace battery.
3	Apply load test (see load test chart) to battery using a battery load tester and record battery voltage after <b>15 seconds</b> . Is voltage more than specification?	Yes	Battery is okay.
		No	Replace battery.

A3U011718520W02

# CHARGING SYSTEM

## Load test chart

Battery	Load (A)
50D20L	150
75D23L	195

## Battery positive voltage with load

Approximate battery temp.	Minimum voltage (V)
21 °C {70 °F}	9.6
15 °C {60 °F}	9.5
10 °C {50 °F}	9.4
4 °C {40 °F}	9.3
-1 °C {30 °F}	9.1
-7 °C {20 °F}	8.9
-12 °C {10 °F}	8.7
-18 °C {0 °F}	8.5

## Back-up Current

1. Verify that the ignition switch is off and that the ignition key has been removed.
2. Disconnect the negative battery cable.

### Caution

- Operating electrical loads while measuring the back-up current can damage the circuit tester.

3. Measure the back-up current between the negative battery terminal and the negative battery cable.
  - (1) If the current exceeds the maximum, remove the fuse in the main fuse block and the fuse block one by one while measuring the back-up current.
  - (2) Inspect and repair harnesses and connectors of the fuse at which the current reduces.

**Back-up current**  
20 mA max.

## BATTERY RECHARGING

### Warning

- Hydrogen gas is produced during normal battery operation. A battery-related explosion can cause serious injury. Keep all flames (including cigarettes), heat, and sparks away from the top and surrounding area of open battery cells.

### Caution

- When disconnecting the battery, remove the negative cable first and install it last to prevent damage to electrical components or the battery.
- To prevent damage to electrical components or the battery, turn all accessories off and stop the engine before performing maintenance or recharging the battery.
- Do not quick charge for over 30 minutes. It will damage the battery.

1. Place a battery in a pan of water to prevent it from overheating. The water level should come up about halfway on the battery. Keep water off the top of the battery.
2. Connect a battery charger to the battery.
3. Adjust the charging current as follows.

Battery type (5-hour rate)	Slow charge (A)	Quick charge (A)/(30 min.)
50D20L (40)	4.0—5.0	25
75D23L (52)	5.5—6.5	35

4. After the battery has been recharged, measure the battery positive voltage and verify that the battery keeps specified voltage for **more than 1 hour**.
  - If not as specified, replace the battery.

### Specification

Above 12.4 V

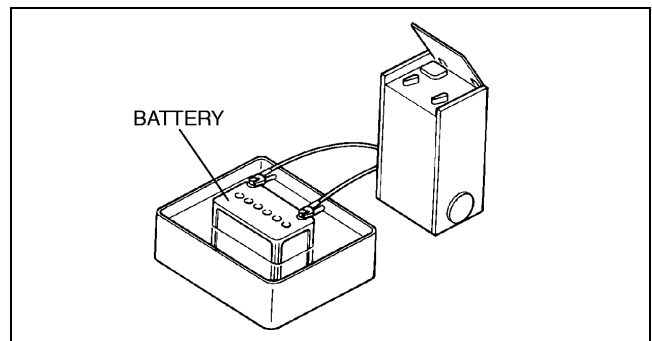

X3U117WA1

# CHARGING SYSTEM

## GENERATOR REMOVAL/INSTALLATION

A3U011718300W01

### Warning

- When the battery cables are connected, touching the vehicle body with generator terminal B will generate sparks. This can cause personal injury, fire, and damage to the electrical components. Always disconnect the battery before performing the following operation.

1. Disconnect the negative battery cable.
2. Remove in the order indicated in the table.
3. Install in the reverse order of removal.

01-17

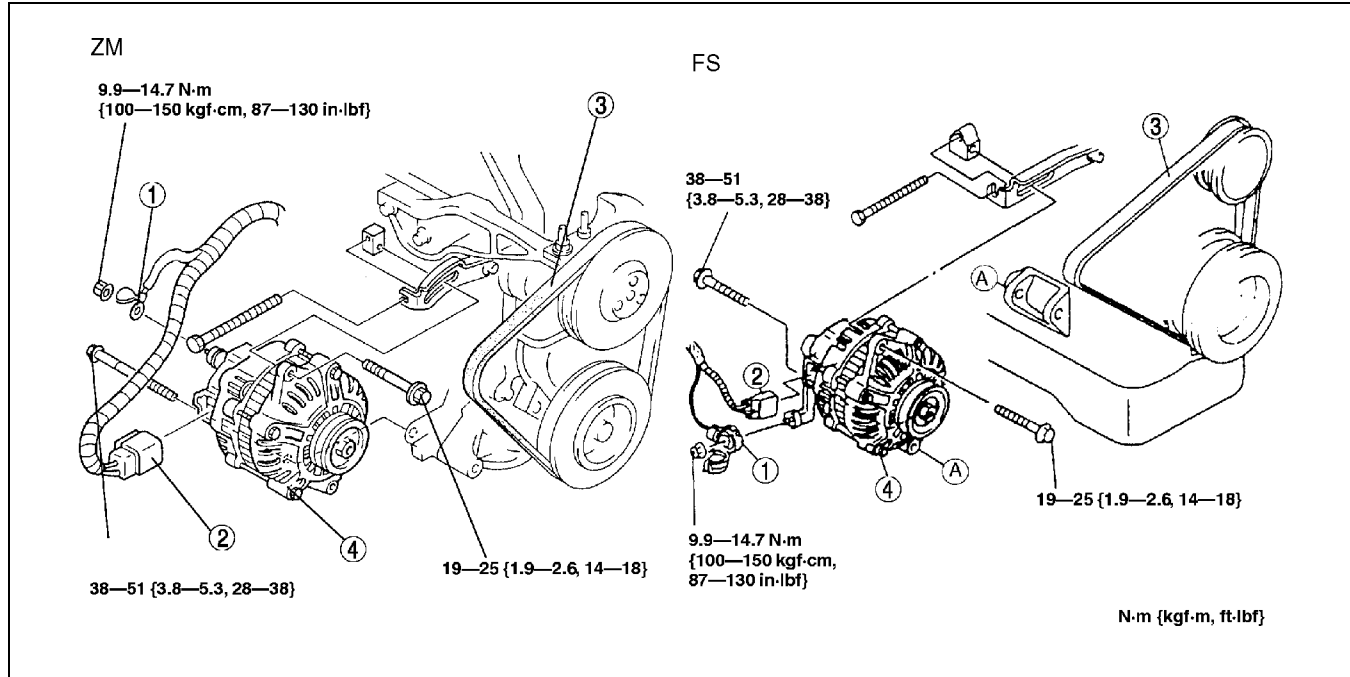

Z3U0117W001

1	Terminal B wire
2	Connector
3	Drive belt (generator) (See 01-17-3 Drive Belt Installation Note)
4	Generator

### Drive Belt Installation Note

- Install the drive belt and adjust the drive belt deflection or tension. (See 01-10A-4 DRIVE BELT ADJUSTMENT [ZM].) (See 01-10B-4 DRIVE BELT ADJUSTMENT [FS].)

## GENERATOR INSPECTION

A3U011718300W02

### Generator Warning Light

1. Verify that the battery is fully charged.
  - Charge if necessary.
2. Verify that the drive belt deflection/tension is within the specification. (See 01-10A-3 DRIVE BELT INSPECTION [ZM].) (See 01-10B-3 DRIVE BELT INSPECTION [FS].)
  - Adjust if necessary.
3. Turn the ignition switch to ON and verify that the generator warning light comes on.
  - If not, inspect generator warning light, wiring harnesses between the battery, generator warning light, and PCM terminal 42. When the generator warning light and the wiring harnesses are okay, replace the PCM.
4. Verify that the generator warning light goes out after the engine is started.
  - If not, inspect if any of the following DTCs are displayed: P0112, P0113, P1631, P1632, P1633, P1634. (See 01-02A-8 ON-BOARD DIAGNOSTIC TEST [ZM].) (See 01-02B-7 ON-BOARD DIAGNOSTIC TEST [FS].)

# CHARGING SYSTEM

## Generator

### Voltage

- Verify that the battery is fully charged.
  - Charge if necessary.
- Verify that the drive belt deflection/tension is within the specification. (See 01-10A-3 DRIVE BELT INSPECTION [ZM].) (See 01-10B-3 DRIVE BELT INSPECTION [FS].)
  - Adjust if necessary.
- Turn off all electrical loads.
- Turn the ignition switch to start the engine and verify that the generator turns smoothly without any noise while the engine is running.
- Measure the voltage at the terminals indicated in the table.
  - If not as specified, repair or replace the generator as necessary.

### Standard voltage

Terminal	Ignition switch ON(V)		Idle (V)[20 °C {68 °F}]	
	ZM	FS	ZM	FS
B	B+		13—15	
P	Approx. 1		Approx.3—8	
D	Approx.0		*	

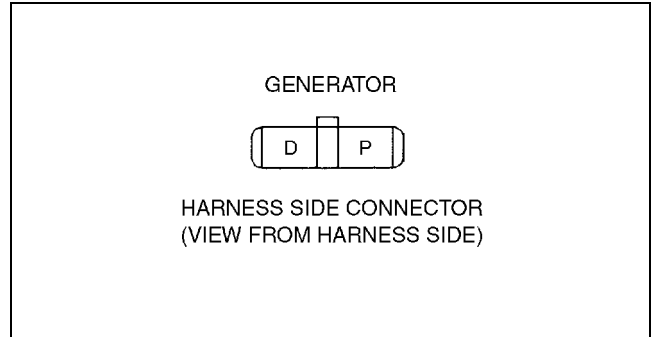

Y3U117WA2

\* : Turn the following electrical loads on and verify that the voltage reading increases.

- Headlights
- Blower motor
- Rear window defroster

### Current

- Verify that the battery is fully charged.
  - Charge if necessary.
- Verify that the drive belt deflection/tension is within the specification. (See 01-10A-3 DRIVE BELT INSPECTION [ZM].) (See 01-10B-3 DRIVE BELT INSPECTION [FS].)
  - Adjust if necessary.
- Disconnect the negative battery cable.
- Connect ammeter, capable of reading **120 A** or above, between generator terminal B and the wiring harness.
- Connect the negative battery cable.
- Turn off all electrical loads.
- Start the engine and increase the engine speed to **2,000—2,500 rpm**.
- Turn the following electrical loads on and verify that the current reading increases.
  - Headlights
  - Blower motor
  - Rear window defroster
    - If generator terminal B current will not increase, repair or replace the generator as necessary.

### Note

- Current required for generating power varies with electrical loads applied.

### Standard current (Reference)

#### Measuring conditions

Room temperature: 20 °C {68 °F}

Voltage: 13.5 V

Engine hot

Engine speed (rpm)	Terminal B current (A)	
	ZM	FS
1,000	0—60*	0—59*
2,000	0—68*	0—77*

\* : Must not be **0 A**.

# 01-18 IGNITION SYSTEM

**IGNITION COIL REMOVAL/INSTALLATION**..... 01-18-1  
**IGNITION COIL INSPECTION**..... 01-18-2  
 Igniter..... 01-18-2  
 Ignition Coil Operation Inspection .... 01-18-2

Secondary Coil Winding .....01-18-2  
 Insulation Resistance of Case.....01-18-2  
**HIGH-TENSION LEAD REMOVAL/INSTALLATION** .....01-18-3  
**HIGH-TENSION LEAD INSPECTION** ...01-18-3

## IGNITION COIL REMOVAL/INSTALLATION

A3U011818100W01

**Caution**

- Disconnecting the ignition coil and plug cap can tear the plug cap off and cause damage to the connecting part. Disconnect the ignition coil and plug cap only when each component needs to be replaced, and be careful not to tear and damage them.

1. Disconnect the negative battery cable.
2. Remove in the order indicated in the table.
3. Install in the reverse order of removal.

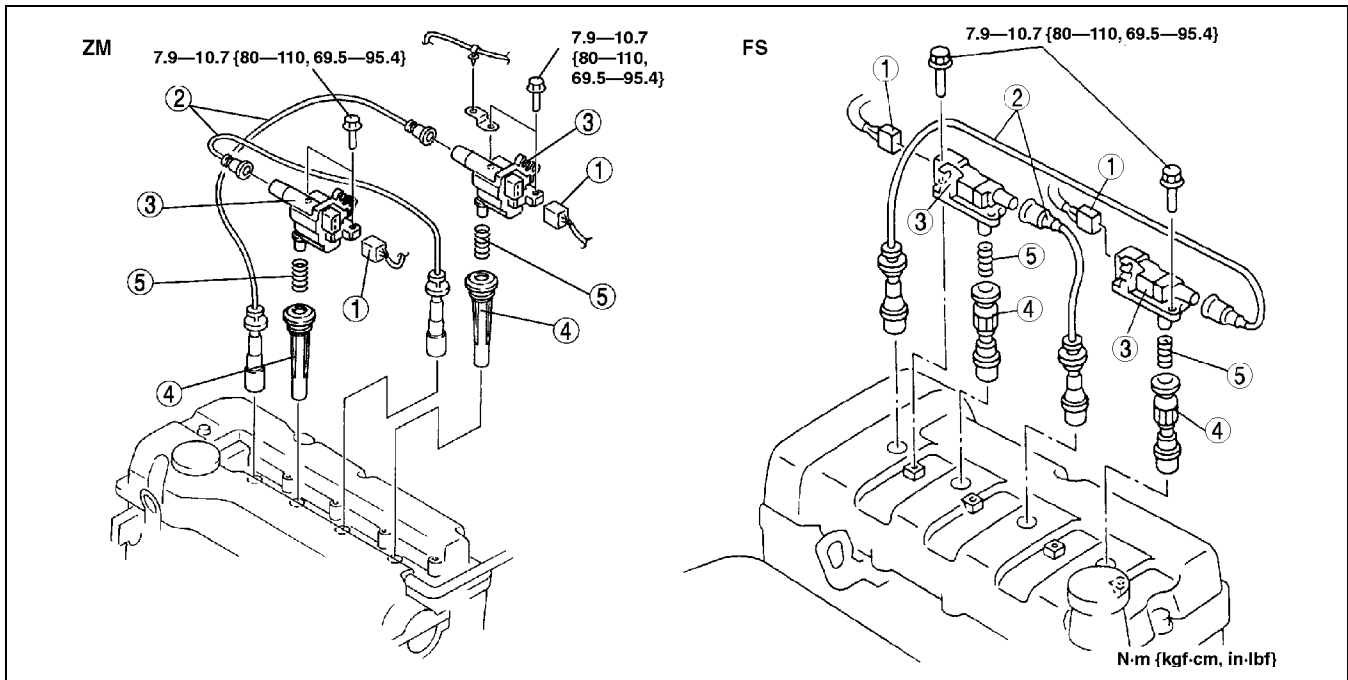

Z3U0118W001

1	Connector
2	High-tension lead (See 01-18-3 HIGH-TENSION LEAD REMOVAL/INSTALLATION)
3	Ignition coil

4	Plug cap
5	Spring

# IGNITION SYSTEM

A3U011818100W02

## IGNITION COIL INSPECTION

### Igniter

- Carry out spark test. (See 01-03A-60 Spark Test.) (See 01-03B-59 Spark Test.)

### Ignition Coil Operation Inspection

1. Remove ignition coils, high-tension leads, and spark plugs.
2. Connect the ignition coil, high-tension lead, spark plug, and the battery as shown in the figure.

#### Caution

- When connecting the ignition coil, be sure to attach as a female terminal to each terminal. Otherwise, coil terminals may come into contact and the ignition coil could be damaged.

#### Note

- Use the high-tension lead and spark plug that function properly.

3. Verify that the spark plug produces a strong, pale spark when change the switch off to on.

#### Warning

- Do not hold the spark plug, high-tension lead, or ignition coil while inspecting the ignition coil. You may be subjected to a strong shock.

#### Note

- No.1 and No.4 cylinders and No.2 and No.3 cylinder are ignited simultaneously.

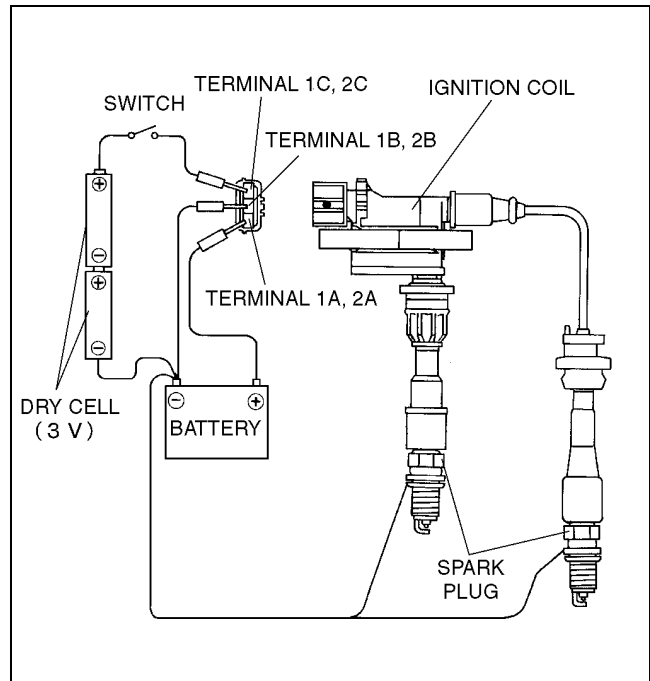

Z3U0118W003

## Secondary Coil Winding

1. Remove the ignition coil.
2. Measure the resistance from lead hole 1 to 4, and lead hole 2 to 3 using an ohmmeter.
  - If not as specified, replace the ignition coil.

### Specification

ZM 8.0—12.0 kilohms

FS 7.2—10.8 kilohms

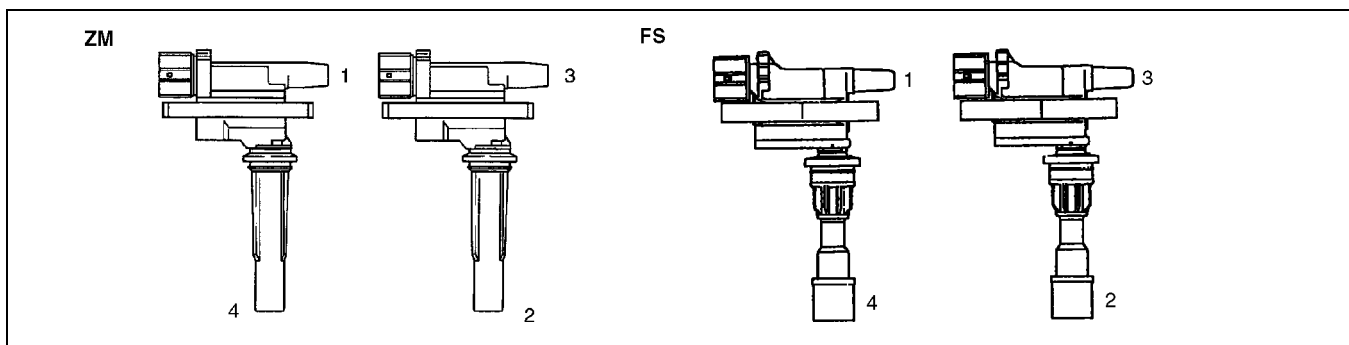

Z3U0118W004

## Insulation Resistance of Case

1. Disconnect the high-tension lead. (See 01-18-3 HIGH-TENSION LEAD REMOVAL/INSTALLATION.)
2. Disconnect the ignition coil connector.
3. Measure the insulation resistance from terminal 1A to ignition coil case, and terminal 2A to ignition coil case using an ohmmeter.
  - If not as specified, replace the ignition coil.



# IGNITION SYSTEM

**Specification**  
Above 10 megohms

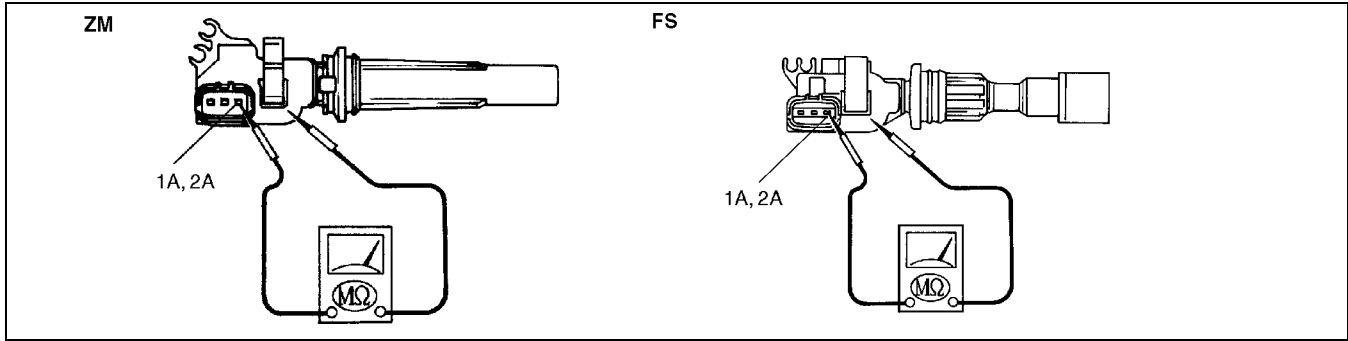

Z3U0118W006

01-18

## HIGH-TENSION LEAD REMOVAL/INSTALLATION

A3U011818140W01

### Caution

- The high-tension leads must be reinstalled to their original positions. Incorrect installation can damage the leads and cause power loss, and negatively affect the electronic components.

## HIGH-TENSION LEAD INSPECTION

- Measure the resistance of the high-tension leads using an ohmmeter.
  - If not as specified, replace the high-tension leads.

A3U011818140W02

### Specification

(kilohm)

High-tension lead	Engine type	
	ZM	FS
No.1 lead	3.3—7.8	5.6—12.1
No.3 lead	2.9—6.9	1.9—4.0

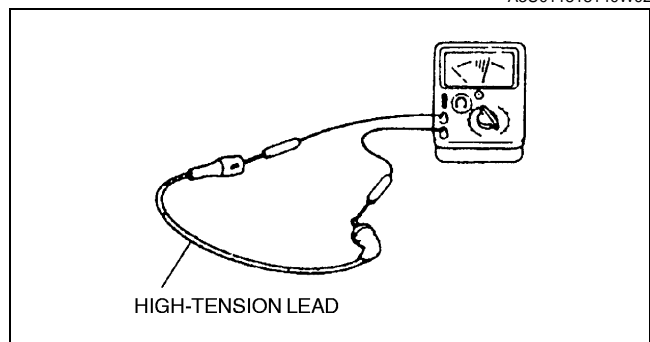

X3U118WA8

# 01-19 STARTING SYSTEM

STARTER REMOVAL/INSTALLATION . 01-19-1  
 STARTER INSPECTION . . . . . 01-19-2  
 On-Vehicle Inspection . . . . . 01-19-2  
 No Load Test . . . . . 01-19-2

STARTER INTERLOCK SWITCH INSPECTION  
 (MTX) . . . . . 01-19-2  
 On-vehicle Inspection . . . . . 01-19-2  
 Continuity Inspection . . . . . 01-19-2

01-19

## STARTER REMOVAL/INSTALLATION

A3U011918400W01

### Warning

- When the battery cables are connected, touching the vehicle body with starter terminal B will generate sparks. This can cause personal injury, fire, and damage to the electrical components. Always disconnect the battery before performing the following operation.

1. Disconnect the negative battery cable.
2. Remove the battery.
3. Remove the intake manifold bracket.
4. Remove in the order indicated in the table.
5. Install in the reverse order of removal.

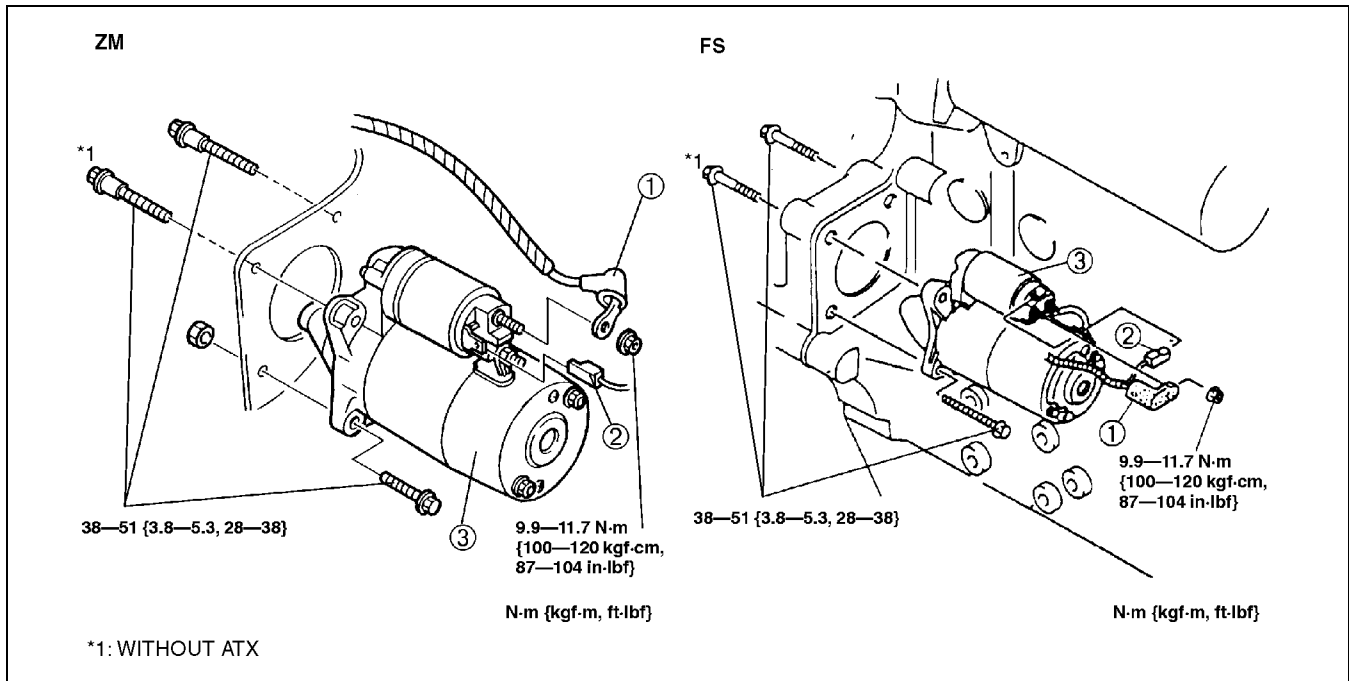

Z3U0119W001

1	Terminal B wire
2	Terminal S wire

3	Starter
---	---------

# STARTING SYSTEM

## STARTER INSPECTION

A3U011918400W02

### On-Vehicle Inspection

1. Verify that the battery is fully charged.
2. Crank the engine and verify that the starter rotates smoothly without any noise.
3. Measure the voltage at terminals S and B when the ignition switch is at START position.
  - If the voltage is within the specification, remove the starter and inspect the magnetic switch and the starter.
  - If the voltage is not as specified, inspect the wiring harness, ignition switch, starter interlock switch (MTX), and transaxle range switch (ATX).

**Specification**  
Above 8 V

### No Load Test

1. Verify that the battery is fully charged.
2. Connect the starter, battery, voltmeter and ammeter as shown.
3. Operate the starter and verify that it rotates smoothly.
4. Measure the voltage and current while the starter is operating.
  - If not as specified, repair or replace the starter as necessary.

**Specification**  
Voltage: 11 V  
Current: below 90 A

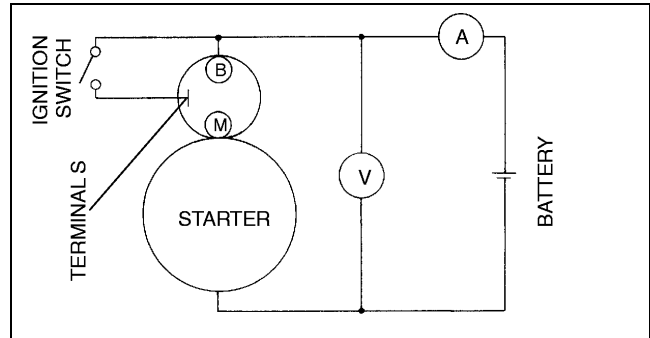

X3U119WA2

## STARTER INTERLOCK SWITCH INSPECTION (MTX)

A3U011943440W01

### On-vehicle Inspection

1. With the clutch pedal not depressed, verify that the engine does not start.
2. With the clutch pedal fully depressed, verify that the engine starts.
  - If the above cannot be verified, carry out continuity inspection.

### Continuity Inspection

1. Disconnect the starter interlock switch connector.
2. Inspect for continuity between terminals of the starter interlock switch using an ohmmeter.
  - If not as specified, replace the starter interlock switch.

○—○ : Continuity

Condition	Terminal	
	A	B
Clutch pedal not depressed		
Clutch pedal depressed	○—○	○—○

X3U119WA3

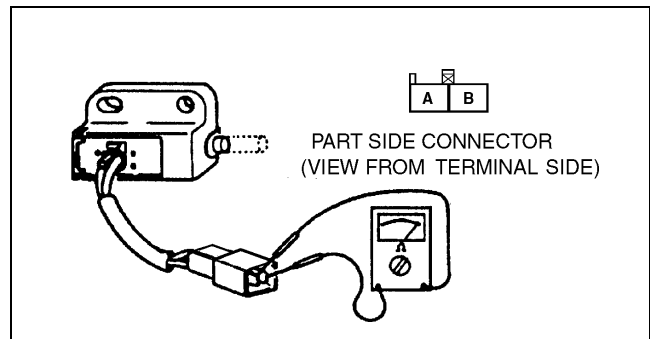

Y3U119WA0

# 01-20 CRUISE CONTROL SYSTEM

LOCATION INDEX ..... 01-20-1  
 CRUISE CONTROL MODULE  
 REMOVAL/INSTALLATION ..... 01-20-2  
 CRUISE CONTROL MODULE  
 INSPECTION ..... 01-20-2  
 Terminal Voltage List (Reference) .... 01-20-2  
 CRUISE ACTUATOR  
 REMOVAL/INSTALLATION ..... 01-20-4

CRUISE ACTUATOR INSPECTION.....01-20-4  
 ACTUATOR CABLE REMOVAL .....01-20-5  
 ACTUATOR CABLE INSTALLATION...01-20-5  
 CRUISE CONTROL SWITCH  
 REMOVAL/INSTALLATION.....01-20-7  
 CRUISE CONTROL SWITCH  
 INSPECTION .....01-20-8

01-20

## LOCATION INDEX

A3U012001011W01

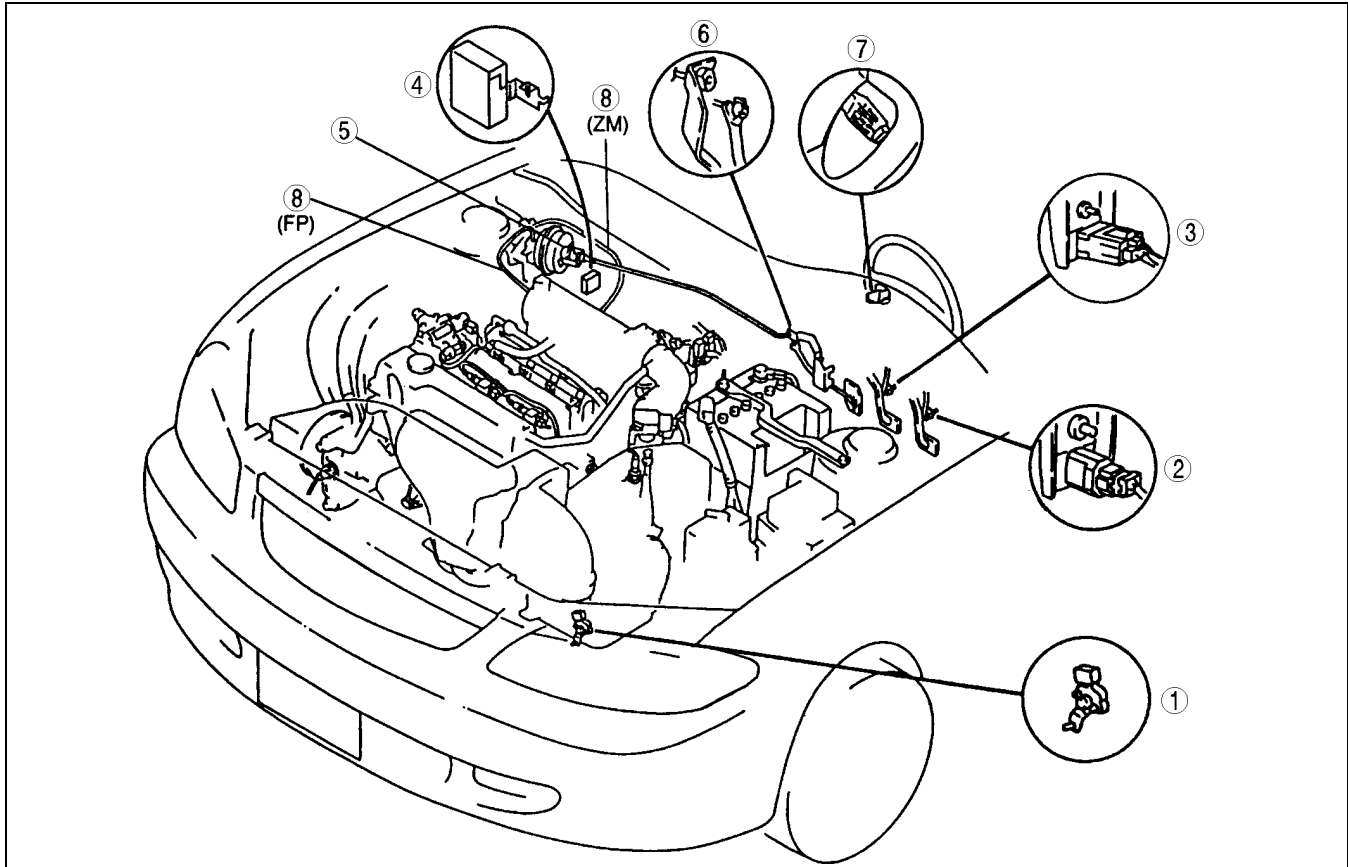

Z3U0120W001

1	Transmission range (TR) switch (ATX) (See 05-17-20 TRANSAXLE RANGE (TR) SWITCH INSPECTION) (See 05-17-20 TRANSAXLE RANGE (TR) SWITCH REMOVAL/INSTALLATION) (See 05-17-23 TRANSAXLE RANGE (TR) SWITCH ADJUSTMENT)
2	Clutch switch (MTX) (See 01-40B-42 CLUTCH SWITCH INSPECTION [FS]) (See 01-40A-41 CLUTCH SWITCH INSPECTION [ZM])
3	Brake switch (See 04-11-5 BRAKE SWITCH INSPECTION)
4	Cruise control module (See 01-20-2 CRUISE CONTROL MODULE REMOVAL/INSTALLATION) (See 01-20-2 CRUISE CONTROL MODULE INSPECTION)

5	Cruise actuator (See 01-20-4 CRUISE ACTUATOR REMOVAL/INSTALLATION) (See 01-20-4 CRUISE ACTUATOR INSPECTION)
6	Actuator cable (See 01-20-5 ACTUATOR CABLE REMOVAL) (See 01-20-5 ACTUATOR CABLE INSTALLATION)
7	Cruise control switch (See 01-20-7 CRUISE CONTROL SWITCH REMOVAL/INSTALLATION) (See 01-20-8 CRUISE CONTROL SWITCH INSPECTION)
8	Vacuum hose

# CRUISE CONTROL SYSTEM

## CRUISE CONTROL MODULE REMOVAL/INSTALLATION

A3U012066320W01

1. Disconnect the negative battery cable.
2. Remove the passenger-side front side trim. (See 09-17-13 FRONT SIDE TRIM REMOVAL/INSTALLATION.)
3. Remove in the order indicated in the table.

1	Connector
2	Bolt
3	Cruise control module

4. Install in the reverse order of removal.

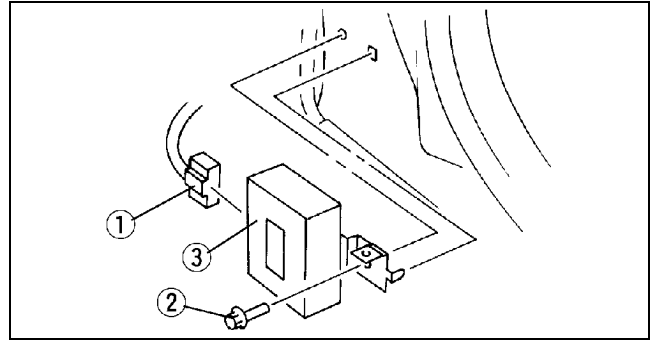

X3U120WA0

## CRUISE CONTROL MODULE INSPECTION

A3U012066320W02

1. Remove the passenger-side front side trim. (See 09-17-13 FRONT SIDE TRIM REMOVAL/INSTALLATION.)
2. Remove the cruise control module without disconnecting the connector.
3. Measure the voltage at the cruise control module terminals as indicated below.
4. Disconnect the cruise control module connector before inspecting for continuity at terminal P.
  - If not as specified, inspect the parts listed under "Action."
  - If the parts and wiring harnesses are okay but the system still does not work properly, replace the cruise control module.

### Terminal Voltage List (Reference)

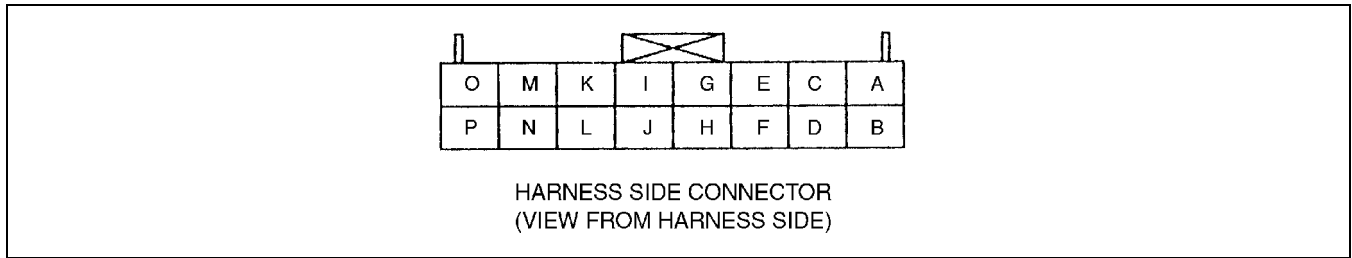

Y3U120WA0

Terminal	Signal	Connected to	Test condition		Voltage (V) /Continuity	Action
A	Cruise actuator control	Cruise actuator (Vent 1)	Ignition switch at ON position	Cruise control main switch at ON position	B+	<ul style="list-style-type: none"> <li>• Inspect brake switch (See 04-11-5 BRAKE SWITCH INSPECTION)</li> <li>• Inspect cruise actuator (See 01-20-4 CRUISE ACTUATOR INSPECTION)</li> <li>• Inspect related harness</li> </ul>
				Other	Below 1.0	
B	Cruise actuator control	Cruise actuator (Vacuum)	Ignition switch at ON position	Cruise control main switch at ON position	B+	<ul style="list-style-type: none"> <li>• Inspect brake switch (See 04-11-5 BRAKE SWITCH INSPECTION)</li> <li>• Inspect cruise actuator (See 01-20-4 CRUISE ACTUATOR INSPECTION)</li> <li>• Inspect related harness</li> </ul>
				Other	Below 1.0	
C	Cruise actuator control	Cruise actuator (Vent 2)	Ignition switch at ON position	Cruise control main switch at ON position	B+	<ul style="list-style-type: none"> <li>• Inspect brake switch (See 04-11-5 BRAKE SWITCH INSPECTION)</li> <li>• Inspect cruise actuator (See 01-20-4 CRUISE ACTUATOR INSPECTION)</li> <li>• Inspect related harness</li> </ul>
				Other	Below 1.0	
D	Cruise set indicator light output	Cruise set indicator light	Ignition switch at ON position	B+	Below 1.0	<ul style="list-style-type: none"> <li>• Inspect METER 10 A fuse</li> <li>• Inspect instrument cluster (See 09-22-4 INSTRUMENT CLUSTER INSPECTION)</li> <li>• Inspect related harness</li> </ul>
			Ignition switch at LOCK or ACC position			

## CRUISE CONTROL SYSTEM

Terminal	Signal	Connected to	Test condition		Voltage (V) /Continuity	Action	
E	IG1	METER 10 A fuse	Ignition switch at ON position		B+	<ul style="list-style-type: none"> <li>Inspect METER 10 A fuse</li> <li>Inspect related harness</li> </ul>	
			Ignition switch at LOCK or ACC position		Below 1.0		
F	—	—	—		—	—	
G	O/D off	PCM	Ignition switch at ON position		B+	<ul style="list-style-type: none"> <li>Inspect PCM (See 01-40A-7 PCM INSPECTION [ZM]) (See 01-40B-7 PCM INSPECTION [FS])</li> <li>Inspect related harness</li> </ul>	
			Ignition switch at LOCK or ACC position		Below 1.0		
H	Cruise actuator power supply	Brake switch	Ignition switch at ON position	Cruise control main switch at ON position	B+	—	
				Cruise control main switch at OFF position	Below 1.0		
I	Test	Data link connector	—		—	—	
J	ATX	Selector lever position	Transaxle range switch	Ignition switch at ON position and cruise control main switch at ON position	Selector lever at N or P range	Below 1.0	<ul style="list-style-type: none"> <li>Inspect transaxle range switch (See 05-17-20 TRANSAXLE RANGE (TR) SWITCH INSPECTION)</li> <li>Inspect related harness</li> </ul>
					Other	B+	
	MTX	Clutch switch on/off	Clutch switch	Ignition switch at ON position and cruise control main switch at ON position	Depress clutch pedal	Below 1.0	
					Other	B+	
K	Brake switch on/off	Brake switch	Depress brake pedal		B+	<ul style="list-style-type: none"> <li>Inspect brake switch (See 04-11-5 BRAKE SWITCH INSPECTION)</li> <li>Inspect related harness</li> </ul>	
			Other		Below 1.0		
L	Cruise control switch position	Cruise control switch	Ignition switch at ON position and cruise control main switch at ON position	SET/COAST switch hold at on	Approx. 1.5	<ul style="list-style-type: none"> <li>Inspect cruise control switch (See 01-20-8 CRUISE CONTROL SWITCH INSPECTION)</li> <li>Inspect related harness</li> </ul>	
				RESUME/ACCEL switch hold at on	Approx. 0.5		
				CANCEL switch hold at on	Approx. 3		
				Other	Approx. 5		
M	Brake switch on/off	Brake switch	Ignition switch at ON position and cruise control main switch at ON position	Depress brake pedal	Below 1.0	<ul style="list-style-type: none"> <li>Inspect brake switch (See 04-11-5 BRAKE SWITCH INSPECTION)</li> <li>Inspect related harness</li> </ul>	
				Other	B+		
N	Vehicle speed	Vehicle speed sensor	Ignition switch at ON position and cruise control main switch at ON position	Rear tires rotating	Alternates below 1.0 and 5	<ul style="list-style-type: none"> <li>Inspect METER 10 A fuse</li> <li>Inspect instrument cluster (See 09-22-4 INSTRUMENT CLUSTER INSPECTION)</li> <li>Inspect related harness</li> </ul>	
				Other	Below 1.0 or 5		
O	Cruise control main switch input	Cruise control switch	Ignition switch at ON position	Cruise control main switch at ON position	Below 1.0	<ul style="list-style-type: none"> <li>Inspect cruise control switch (See 01-20-8 CRUISE CONTROL SWITCH INSPECTION)</li> <li>Inspect related harness</li> </ul>	
				Other	B+		
P	Cruise control module ground	GND	Constant: inspect for continuity to ground		Yes	<ul style="list-style-type: none"> <li>Inspect related harness</li> </ul>	

# CRUISE CONTROL SYSTEM

## CRUISE ACTUATOR REMOVAL/INSTALLATION

A3U012066310W01

1. Disconnect the negative battery cable.
2. Remove in the order indicated in the table.
3. Install in the reverse order of removal.

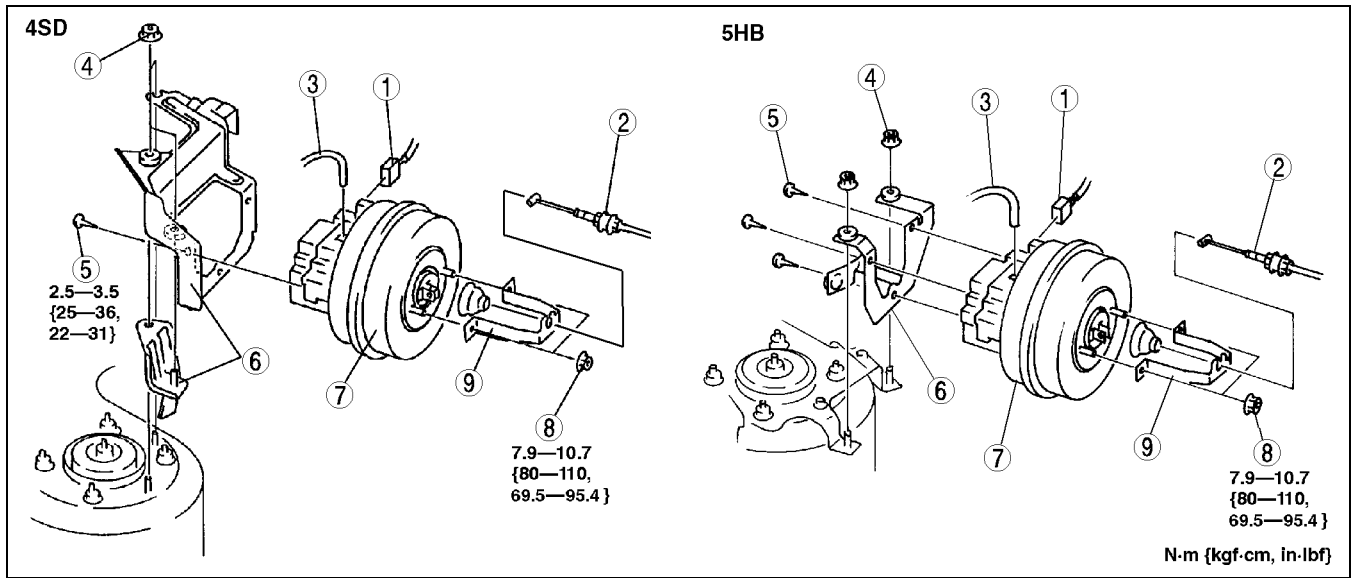

A3U0120W101

1	Cruise actuator connector
2	Actuator cable (See 01-20-5 ACTUATOR CABLE REMOVAL) (See 01-20-5 ACTUATOR CABLE INSTALLATION)
3	Vacuum hose

4	Nut
5	Screw
6	Bracket
7	Cruise actuator
8	Nut
9	Bracket

## CRUISE ACTUATOR INSPECTION

A3U012066310W02

1. Disconnect the negative battery cable.
2. Disconnect the cruise actuator connector.
3. Measure the resistance between the cruise actuator terminals using an ohmmeter.

○—○ : Resistance

Step	Terminal				
	A	B	C	D	
1	○—○				R <sub>1</sub>
2		○—○			R <sub>2</sub>
3			○—○	○	R <sub>3</sub>

R<sub>1</sub>: Approx. 55 ohms R<sub>2</sub>: Approx. 21 ohms  
R<sub>3</sub>: Approx. 55 ohms

Z3U0120W003

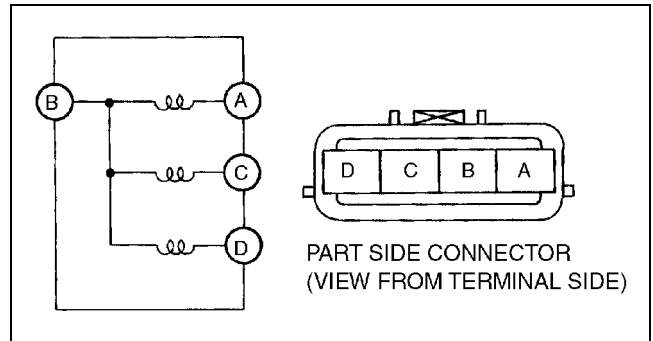

Y3U120WA2

4. Disconnect the actuator cable from the accelerator pedal.
5. Allow the engine to idle.
6. Connect B+ and a ground to the terminals as shown and confirm the operation of the actuator cable.
  - If not as specified, replace the cruise actuator.

Step	Terminal connection				Operation of actuator cable
	A	B	C	D	
1	Ground	B+	Ground	Ground	Pull
2	Ground	B+	—	Ground	Hold
3	—	B+	—	Ground	Extend
4	—	—	—	—	Released

# CRUISE CONTROL SYSTEM

## ACTUATOR CABLE REMOVAL

1. Loosen the nut, and remove the actuator cable.

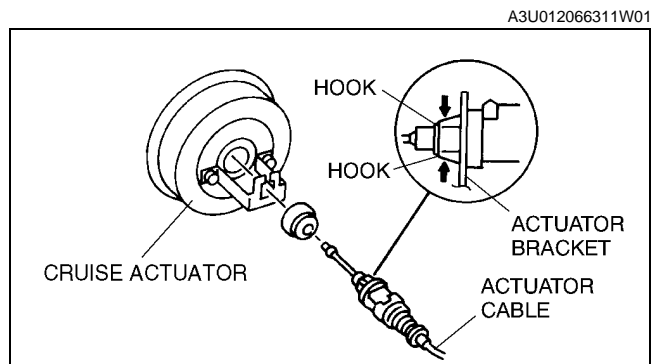

2. Press the tabs of the bush, and remove it from the accelerator pedal.

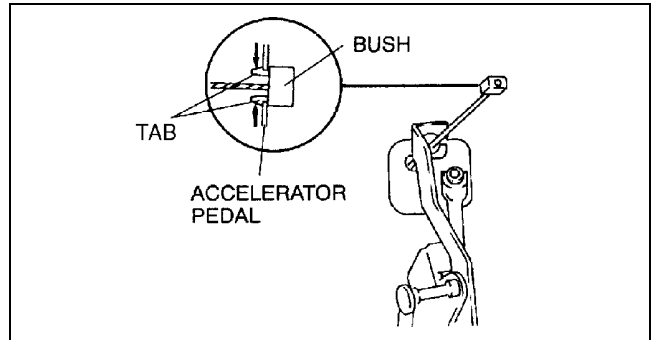

3. Press the tabs of the grommet, and remove it from the dash lower panel.
4. Push the actuator cable through the dash lower panel to remove it.

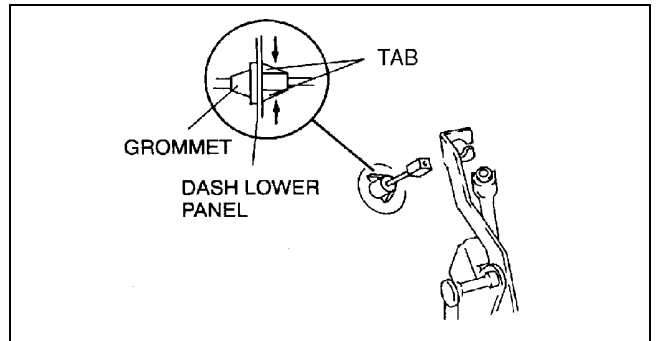

## ACTUATOR CABLE INSTALLATION

1. Install the grommet to the dash lower panel.

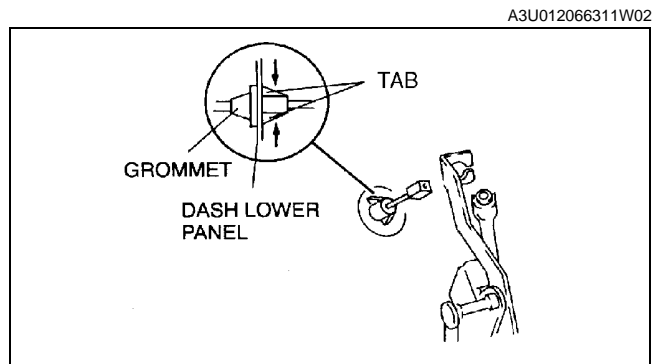

Y3U120WA6



## CRUISE CONTROL SYSTEM

2. Install the actuator cable to the accelerator pedal.

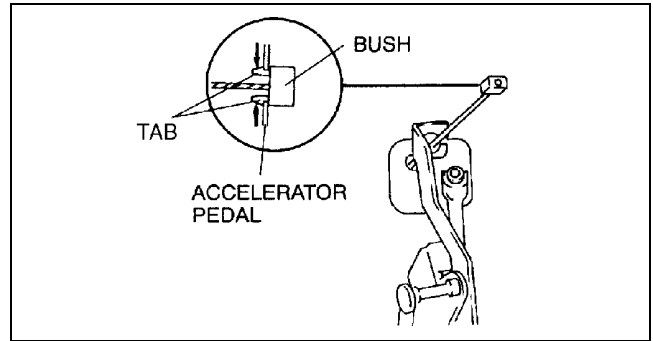

Y3U120WA5

3. Slide the lock lever in the direction shown by the arrow to unlock the adjuster.

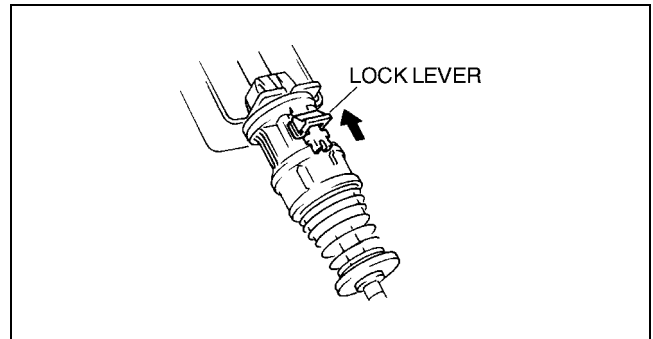

YMU120WAA

4. Turn the ratchet ring to release lock in the direction shown by the arrow.

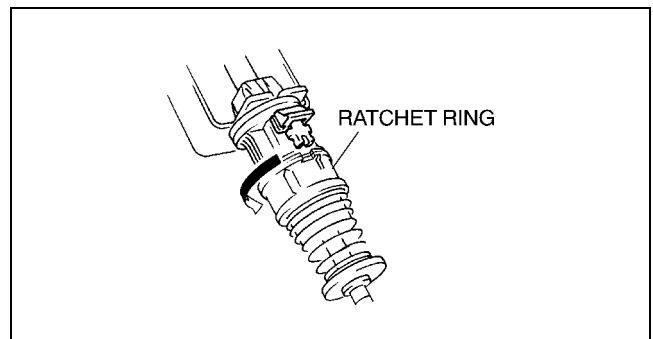

YMU120WAB

5. Insert the grommet into the actuator bracket.

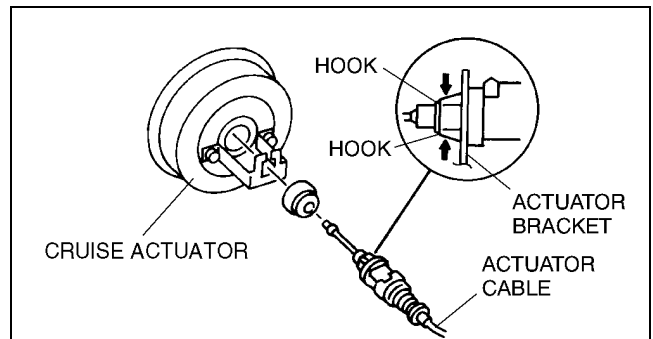

Z3U0120W004

6. To adjust the free play, push or pull the actuator cable directly behind the spring **two times**.

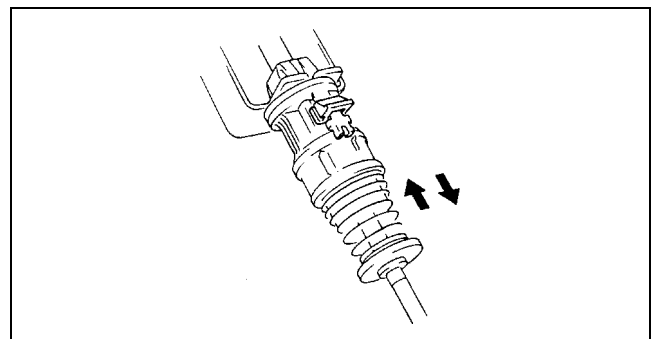

YMU120WAJ

# CRUISE CONTROL SYSTEM

- Turn the ratchet ring in the direction shown by the arrow to lock it.

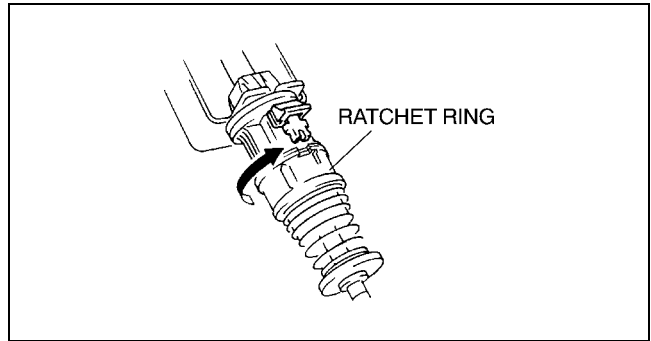

YMU120WAC

- Slide the lock lever in the direction shown by the arrow to lock the adjuster.

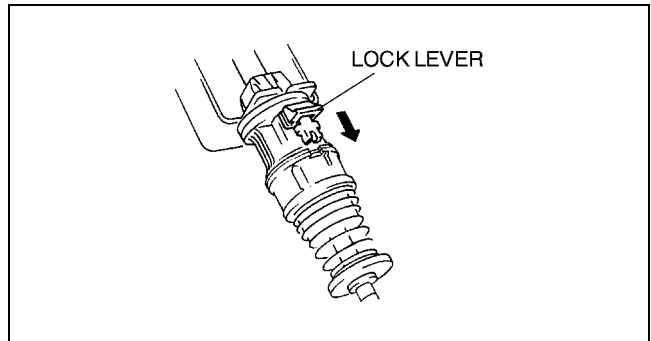

YMU120WAD

01-20

## CRUISE CONTROL SWITCH REMOVAL/INSTALLATION

A3U012066341W01

- Disconnect the negative battery cable.
- Remove the driver-side air bag module. (See 08-10-5 DRIVER-SIDE AIR BAG MODULE REMOVAL/INSTALLATION.)
- Disconnect the cruise control switch connector.
- Remove in the order indicated in the table.

1	Screw (4SD)
2	Horn button contact (4SD)
3	Screw
4	Cruise control switch

- Install in the reverse order of removal.

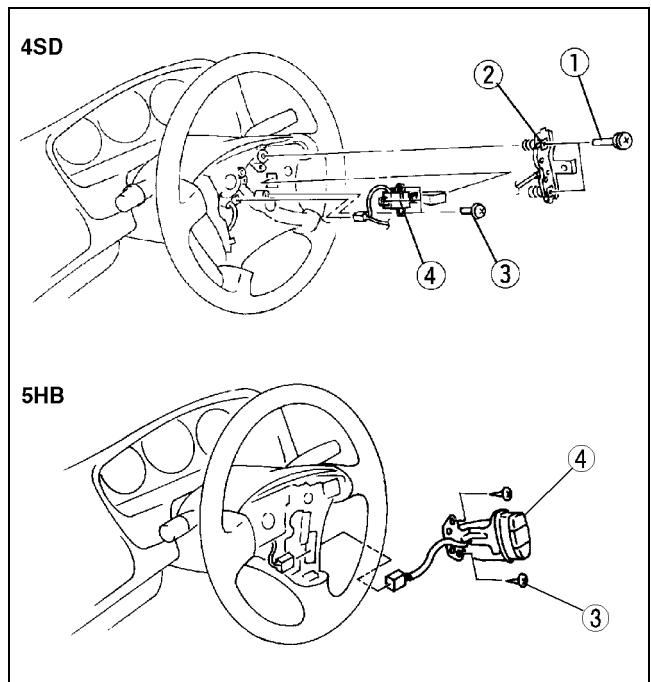

A3U0120W102

# CRUISE CONTROL SYSTEM

A3U012066341W02

## CRUISE CONTROL SWITCH INSPECTION

1. Disconnect the negative battery cable.
2. Remove the driver-side air bag module. (See 08-10-5 DRIVER-SIDE AIR BAG MODULE REMOVAL/INSTALLATION.)
3. Disconnect the cruise control switch connector.
4. Measure the resistance and inspect for continuity between the cruise control switch terminals using an ohmmeter.

○—○ : Continuity    ○○ : Resistance

Switch position	Terminal		
	A	B	C
Cruise control main switch at ON position	○—○		
RESUME/ACCEL switch hold at on	○—		○ R <sub>1</sub>
SET/COAST switch hold at on	○—		○ R <sub>2</sub>
CANCEL switch hold at on	○—		○ R <sub>3</sub>
Other			

R<sub>1</sub> : Approx. 68 ohms    R<sub>2</sub>: Approx. 198 ohms  
R<sub>3</sub>: Approx. 418 ohms

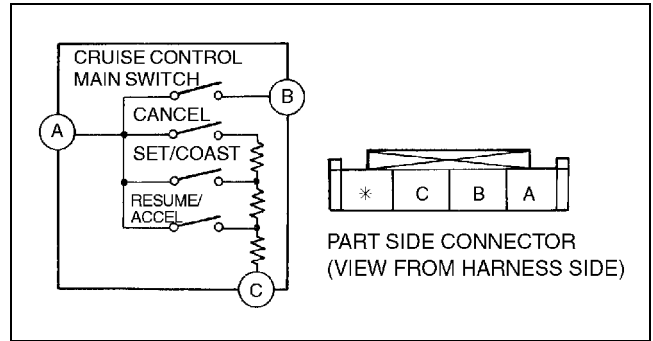

Y3U120WA4

**01-40A CONTROL SYSTEM [ZM]**

<b>CONTROL SYSTEM COMPONENT</b>		<b>CRANKSHAFT POSITION (CKP) SENSOR</b>	
LOCATION INDEX [ZM] . . . . .	01-40A-2	INSPECTION [ZM] . . . . .	01-40A-32
<b>CONTROL SYSTEM DIAGRAM [ZM]</b> . . .	01-40A-4	Air Gap Inspection . . . . .	01-40A-32
<b>CONTROL SYSTEM WIRING</b>		Resistance Inspection . . . . .	01-40A-33
<b>DIAGRAM [ZM]</b> . . . . .	01-40A-5	Circuit Open/Short Inspection . . . . .	01-40A-33
<b>PCM REMOVAL/INSTALLATION [ZM]</b> . . .	01-40A-7	<b>CRANKSHAFT POSITION (CKP) SENSOR</b>	
<b>PCM INSPECTION [ZM]</b> . . . . .	01-40A-7	<b>ADJUSTMENT [ZM]</b> . . . . .	01-40A-34
PCM Inspection Using the SST		<b>CRANKSHAFT POSITION (CKP) SENSOR</b>	
(WDS or equivalent) . . . . .	01-40A-7	<b>REMOVAL/INSTALLATION [ZM]</b> . . . . .	01-40A-34
PCM Inspection Using the SST		<b>PLATE REMOVAL/INSTALLATION</b>	
(104 Pin Breakout Box) . . . . .	01-40A-12	<b>[ZM]</b> . . . . .	01-40A-34
Inspection Using An Oscilloscope		<b>CAMSHAFT POSITION (CMP) SENSOR</b>	
(Reference) . . . . .	01-40A-21	<b>REMOVAL/INSTALLATION [ZM]</b> . . . . .	01-40A-35
<b>INSPECTION USING AN</b>		<b>CAMSHAFT POSITION (CMP) SENSOR</b>	
<b>OSCILLOSCOPE (REFERENCE) [ZM]</b> . . . . .	01-40A-25	<b>INSPECTION [ZM]</b> . . . . .	01-40A-35
Purpose . . . . .	01-40A-25	Visual Inspection . . . . .	01-40A-35
<b>MASS AIR FLOW (MAF)/INTAKE AIR</b>		Wave profile Inspection . . . . .	01-40A-35
<b>TEMPERATURE (IAT) SENSOR</b>		Circuit Open/Short Inspection . . . . .	01-40A-36
<b>INSPECTION [ZM]</b> . . . . .	01-40A-26	<b>HEATED OXYGEN SENSOR (HO2S)</b>	
MAF Sensor Inspection . . . . .	01-40A-26	<b>INSPECTION [ZM]</b> . . . . .	01-40A-36
Circuit Open/Short Inspection . . . . .	01-40A-26	HO2S (Front and Rear) Voltage	
IAT Sensor Resistance Inspection . . . . .	01-40A-27	Inspection . . . . .	01-40A-36
Circuit Open/Short Inspection . . . . .	01-40A-28	HO2S Heater (Front and Rear)	
<b>THROTTLE POSITION (TP) SENSOR</b>		Resistance Inspection . . . . .	01-40A-37
<b>INSPECTION [ZM]</b> . . . . .	01-40A-28	<b>EGR BOOST SENSOR INSPECTION</b>	
Resistance Inspection . . . . .	01-40A-28	<b>[ZM]</b> . . . . .	01-40A-38
Circuit Open/Short Inspection . . . . .	01-40A-29	Circuit Open/Short Inspection . . . . .	01-40A-39
<b>THROTTLE POSITION (TP) SENSOR</b>		<b>FUEL TANK PRESSURE SENSOR</b>	
<b>REMOVAL/INSTALLATION [ZM]</b> . . . . .	01-40A-30	<b>INSPECTION [ZM]</b> . . . . .	01-40A-40
<b>ENGINE COOLANT TEMPERATURE</b>		Circuit Open/Short Inspection . . . . .	01-40A-41
<b>(ECT) SENSOR</b>		<b>CLUTCH SWITCH INSPECTION [ZM]</b> . . . . .	01-40A-41
<b>REMOVAL/INSTALLATION [ZM]</b> . . . . .	01-40A-30	Circuit Open/Short Inspection . . . . .	01-40A-42
<b>ENGINE COOLANT TEMPERATURE</b>		<b>NEUTRAL SWITCH INSPECTION [ZM]</b> . . . . .	01-40A-42
<b>(ECT) SENSOR INSPECTION [ZM]</b> . . . . .	01-40A-31	Circuit Open/Short Inspection . . . . .	01-40A-43
ECT Sensor Resistance Inspection . . . . .	01-40A-31	<b>POWER STEERING PRESSURE (PSP)</b>	
Circuit Open/Short Inspection . . . . .	01-40A-32	<b>SWITCH INSPECTION [ZM]</b> . . . . .	01-40A-43
		Continuity Inspection . . . . .	01-40A-43
		Circuit Open/Short Inspection . . . . .	01-40A-44

# CONTROL SYSTEM [ZM]

## CONTROL SYSTEM COMPONENT LOCATION INDEX [ZM]

A3U014018881W05

### Engine compartment side

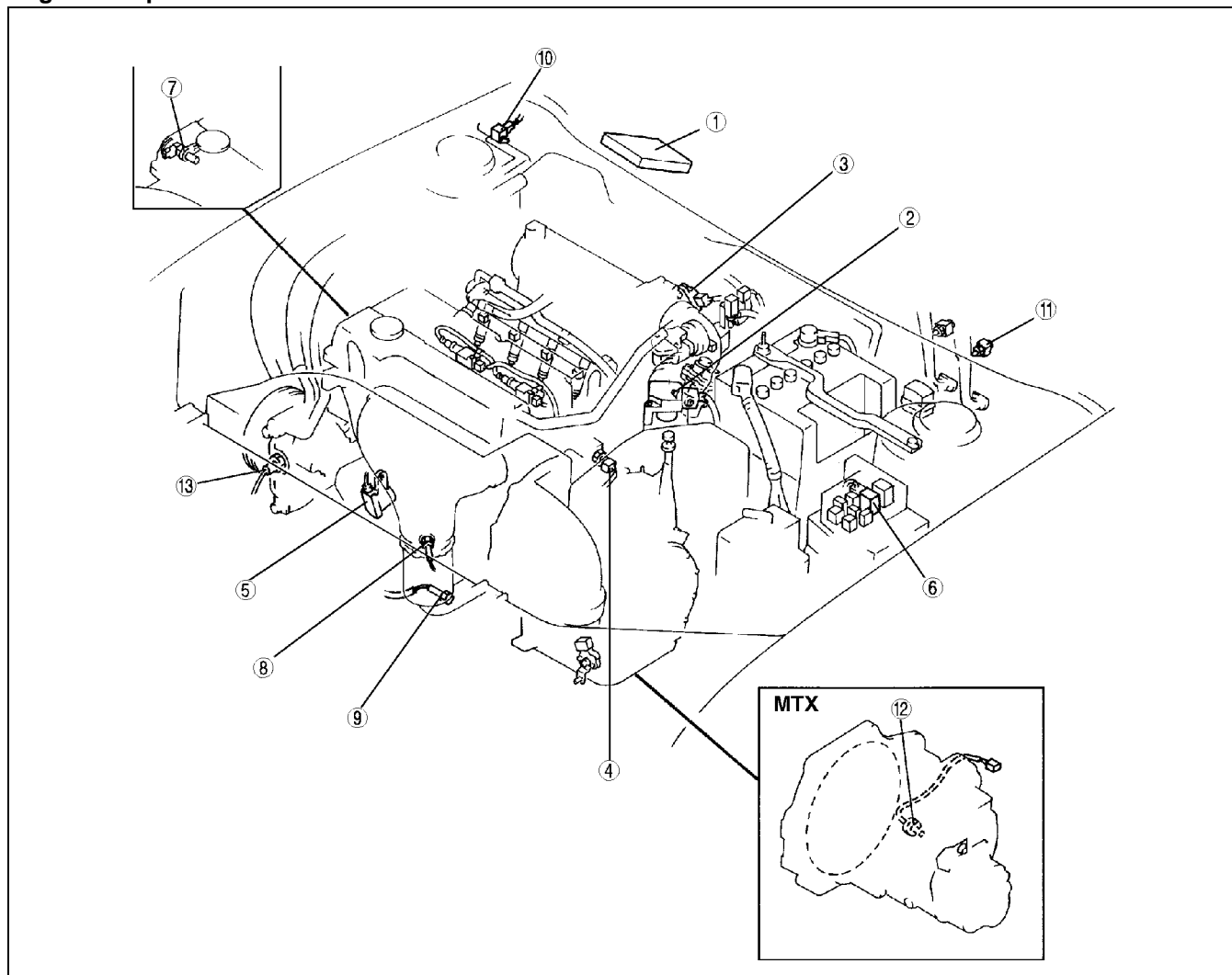

Z3U0140W001

1	PCM (See 01-40A-7 PCM REMOVAL/INSTALLATION [ZM]) (See 01-40A-7 PCM INSPECTION [ZM])
2	Mass air flow (MAF)/intake air temperature (IAT) sensor (See 01-40A-26 MASS AIR FLOW (MAF)/INTAKE AIR TEMPERATURE (IAT) SENSOR INSPECTION [ZM])
3	Throttle position (TP) sensor (See 01-40A-28 THROTTLE POSITION (TP) SENSOR INSPECTION [ZM]) (See 01-40A-30 THROTTLE POSITION (TP) SENSOR REMOVAL/INSTALLATION [ZM])
4	Engine coolant temperature (ECT) sensor (See 01-40A-30 ENGINE COOLANT TEMPERATURE (ECT) SENSOR REMOVAL/INSTALLATION [ZM]) (See 01-40A-31 ENGINE COOLANT TEMPERATURE (ECT) SENSOR INSPECTION [ZM])

5	Crankshaft position (CKP) sensor (See 01-40A-32 CRANKSHAFT POSITION (CKP) SENSOR INSPECTION [ZM]) (See 01-40A-34 CRANKSHAFT POSITION (CKP) SENSOR ADJUSTMENT [ZM]) (See 01-40A-34 CRANKSHAFT POSITION (CKP) SENSOR REMOVAL/INSTALLATION [ZM])
6	Main relay (See 09-21-5 RELAY INSPECTION)
7	Camshaft position (CMP) sensor (See 01-40A-35 CAMSHAFT POSITION (CMP) SENSOR REMOVAL/INSTALLATION [ZM]) (See 01-40A-35 CAMSHAFT POSITION (CMP) SENSOR INSPECTION [ZM])
8	Heated oxygen sensor (front) (See 01-40A-36 HEATED OXYGEN SENSOR (HO2S) INSPECTION [ZM])
9	Heated oxygen sensor (rear) (See 01-40A-36 HEATED OXYGEN SENSOR (HO2S) INSPECTION [ZM])
10	EGR boost sensor (See 01-40A-38 EGR BOOST SENSOR INSPECTION [ZM])
11	Clutch switch (See 01-40A-41 CLUTCH SWITCH INSPECTION [ZM])

## CONTROL SYSTEM [ZM]

12	Neutral switch (See 01-40A-42 NEUTRAL SWITCH INSPECTION [ZM])
----	--

13	Power steering pressure (PSP) switch (See 01-40A-43 POWER STEERING PRESSURE (PSP) SWITCH INSPECTION [ZM])
----	--

### Fuel tank side

01-40A

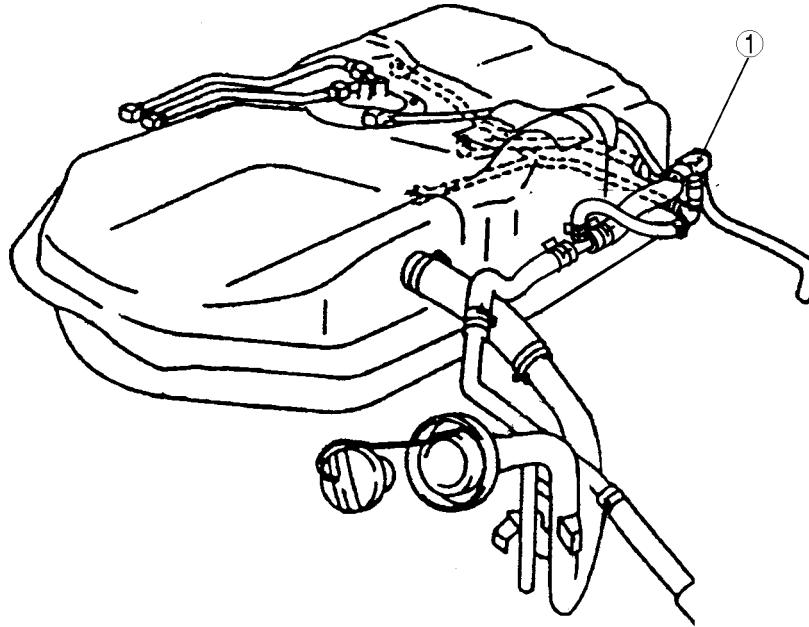

Z3U0140W002

1	Fuel tank pressure sensor (See 01-40A-40 FUEL TANK PRESSURE SENSOR INSPECTION [ZM])
---	--

# CONTROL SYSTEM [ZM]

## CONTROL SYSTEM DIAGRAM [ZM]

A3U014018881W06

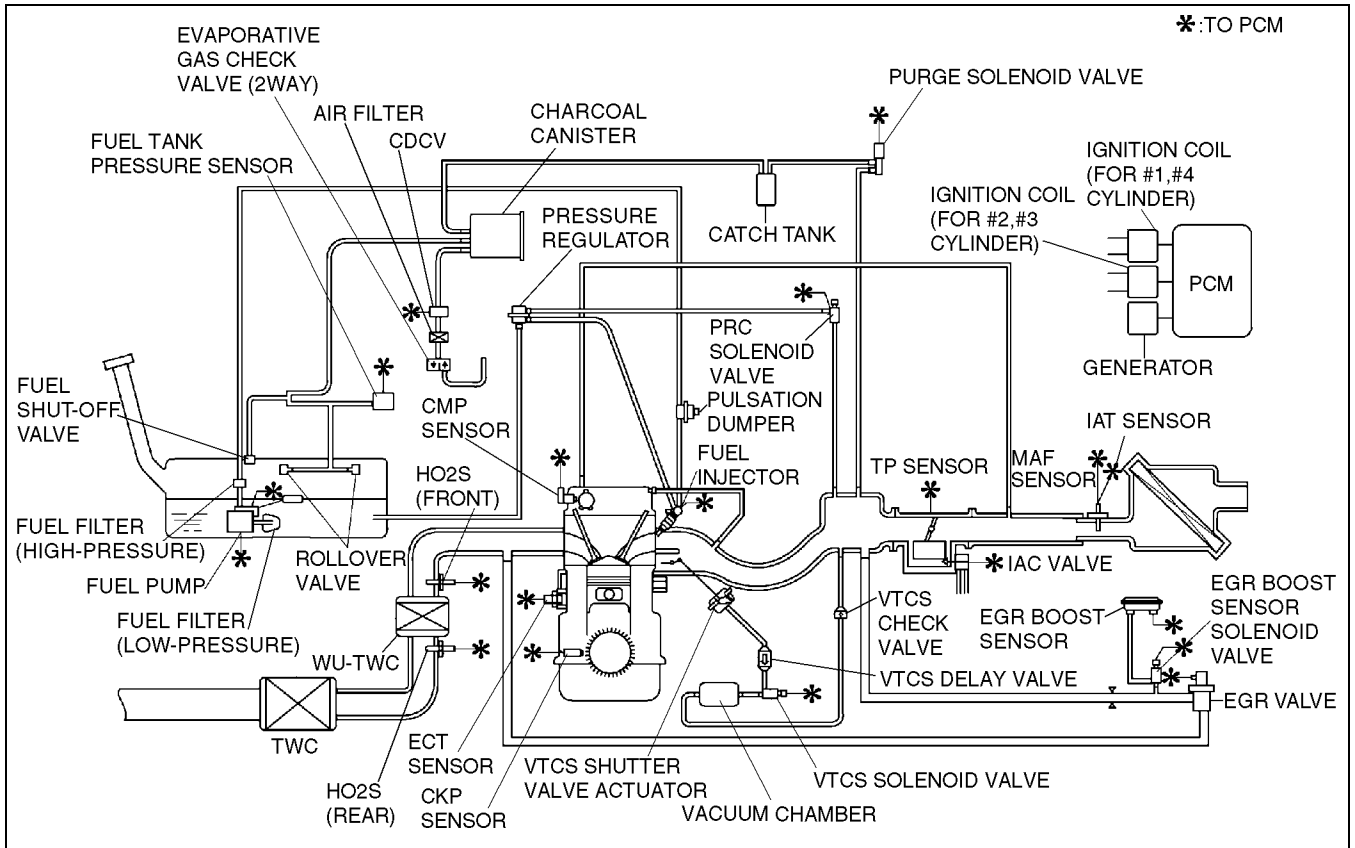

Z3U0140W003

# CONTROL SYSTEM [ZM]

## CONTROL SYSTEM WIRING DIAGRAM [ZM]

A3U014018881W07

01-40A

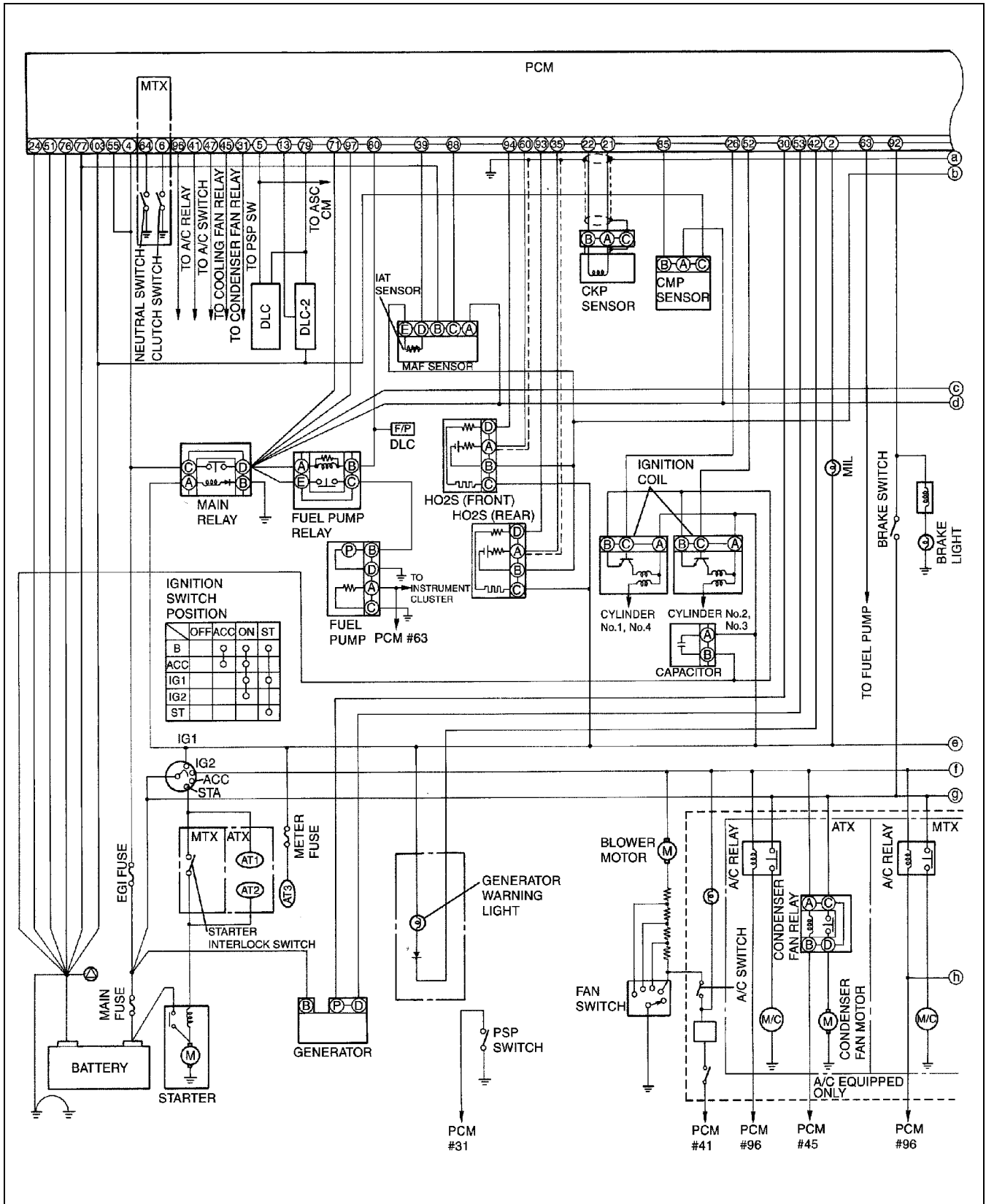

A3U0140W005



# CONTROL SYSTEM [ZM]

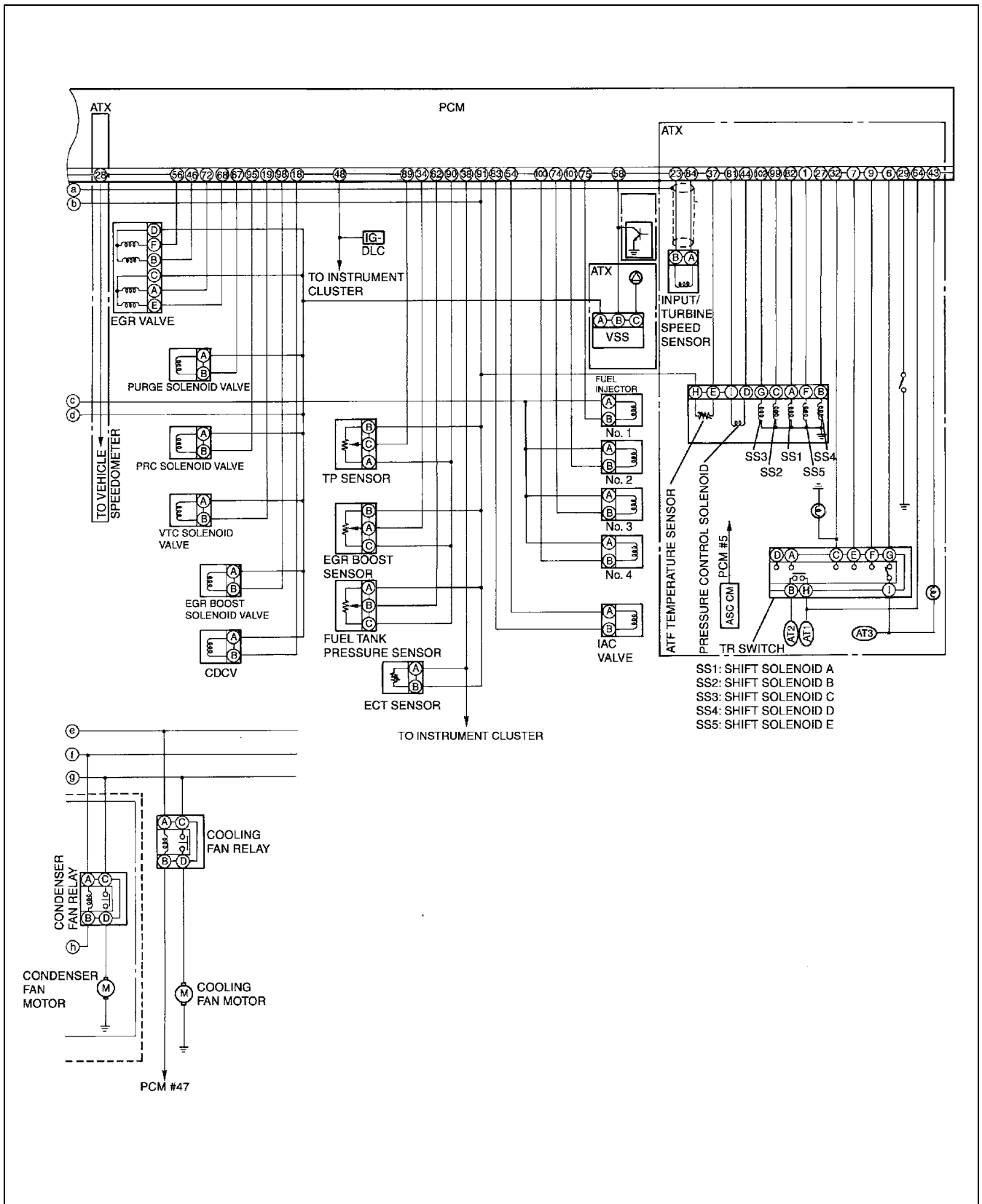

Z3U0140W005

## PCM REMOVAL/INSTALLATION [ZM]

A3U014018880W03

1. Disconnect the negative battery cable.
2. Remove the front passenger side scuff plate.
3. Remove the front passenger side trims.
4. Partially peel off the floor covering from the front of the passenger's side.

### Warning

- The edge of the PCM plate is sharp. Be careful not to cut yourself when handling the PCM plate.

5. Remove in the order indicated in the table.
6. Install in the reverse order of removal.

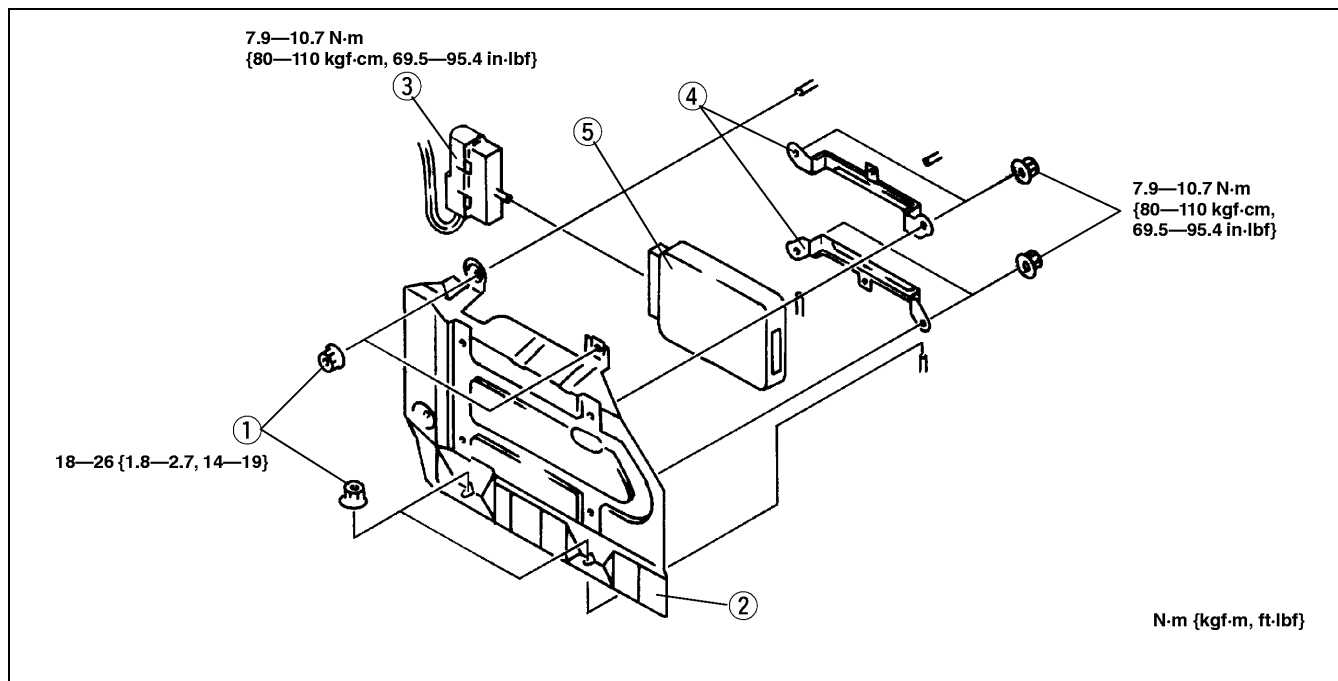

X3U140WA1

1	Nut
2	PCM panel
3	PCM connector

4	Bracket
5	PCM

## PCM INSPECTION [ZM]

A3U014018880W04

### Caution

- The PCM terminal voltages vary with change in measuring conditions and vehicle conditions. Always complete the inspection of the input systems, output systems, and PCM to determine the cause of trouble. Otherwise, a wrong diagnosis will fail.

### PCM Inspection Using the SST (WDS or equivalent)

#### Note

- PIDs for the following parts are not available on this model. Go to the appropriate part inspection page.
  - CMP sensor (See 01-40A-35 CAMSHAFT POSITION (CMP) SENSOR INSPECTION [ZM].)
  - Main relay (See 09-21-5 RELAY INSPECTION.)

1. Connect the WDS or equivalent to the DLC-2. (See 01-02A-8 ON-BOARD DIAGNOSTIC TEST [ZM].)
2. Turn the ignition switch to ON.
3. Measure the value.
  - If the value is not within the specification, follow the instruction in action column.

## CONTROL SYSTEM [ZM]

**PID/DATA MONITOR table (Reference)**

Monitor item (Definition)	Unit/ Condition		Condition/Specification (Reference)	Action	PCM terminal
ACCS (A/C relay)	ON/OFF		A/C operating: ON Ignition switch ON: OFF	Inspect following PIDs: RPM, TP, ECT, ACSW Inspect A/C relay (See 09-21-5 RELAY INSPECTION)	96
ACSW (A/C switch)	ON/OFF		A/C switch and fan switch ON: ON A/C switch OFF: OFF	Inspect A/C switch (See 07-40-11 CLIMATE CONTROL UNIT INSPECTION)	41
ALTF (Generator field coil control duty value)	%		Ignition switch ON: 0% Idle: 0—100% Generator operating → E/L ON: Duty value rise	Inspect following PIDs: IAT, RPM, VPWR, B+2, ALTT V Inspect generator (See 01-17-3 GENERATOR INSPECTION)	53
ALTT V (Generator output voltage)	V		Ignition switch ON: 0 V Idle: 14—16 V	Inspect following PIDs: IAT, RPM, VPWR, B+2, ALTF Inspect generator (See 01-17-3 GENERATOR INSPECTION)	30
ARPMDES (Target engine speed)	rpm		Idle (No load): 650—750 rpm	Perform "On-Board Diagnostic Test" (See 01-02A-8 ON-BOARD DIAGNOSTIC TEST [ZM])	—
BARO (Barometric pressure)	kPa	inHg	Below 400 m {0.25 mile} above sea level: 99—103 kPa {29—30 inHg}	Inspect EGR boost sensor (See 01-40A-38 EGR BOOST SENSOR INSPECTION [ZM])	34
	V		Below 400 m {0.25 mile} above sea level: 4.1—4.3 V	Inspect EGR boost sensor (See 01-40A-38 EGR BOOST SENSOR INSPECTION [ZM])	34
BOO (Brake switch)	ON/OFF		Brake pedal depressed: ON Brake pedal released: OFF	Inspect brake switch (See 04-11-5 BRAKE SWITCH INSPECTION)	92
B+2 (PCM back-up positive voltage)	V		Constant: B+	Inspect battery (See 01-17-1 BATTERY INSPECTION)	4
CDCV (Canister drain cut valve)	ON/OFF		Ignition switch ON: OFF Idle: OFF	Inspect CDCV (See 01-16-10 CANISTER DRAIN CUT VALVE (CDCV) INSPECTION)	18
CHRGLP (Generator warning light)	ON/OFF		Ignition switch ON: ON Idle: OFF	Inspect generator warning light	42
CPP*2 (Clutch switch)	ON/OFF		Clutch pedal depressed: ON Clutch pedal released: OFF	Inspect clutch switch (See 01-40A-41 CLUTCH SWITCH INSPECTION [ZM])	6
ECT (Engine coolant temperature)	°C	°F	ECT 20 °C {68 °F}: 20 °C {68 °F} ECT 60 °C {140 °F}: 60 °C {140 °F}	Inspect ECT sensor (See 01-40A-31 ENGINE COOLANT TEMPERATURE (ECT) SENSOR INSPECTION [ZM])	38
	V		ECT 20 °C {68 °F}: 2.9—3.1 V After warm up: 0.2—1.0 V	Inspect ECT sensor (See 01-40A-31 ENGINE COOLANT TEMPERATURE (ECT) SENSOR INSPECTION [ZM])	38
EGRCHK (EGR boost sensor solenoid valve)	ON/OFF		Ignition switch ON: OFF Idle: OFF	Inspect EGR boost sensor solenoid valve (See 01-16-17 EGR BOOST SENSOR SOLENOID VALVE INSPECTION)	98
EVAPCP (Purge solenoid valve duty value)	%		Ignition switch ON: 0% Idle: 0%	Inspect following PIDs: IAT, RPM, ECT, MAF, TP, BARO, O2S11, VPWR Inspect purge solenoid valve (See 01-16-12 PURGE SOLENOID VALVE INSPECTION)	67
FAN2 (Condenser fan control)	ON/OFF		A/C operated: ON Others: OFF	Inspect following PIDs: RPM, TP, ECT, ACSW, TEST Inspect condenser fan relay (See 09-21-5 RELAY INSPECTION)	45

## CONTROL SYSTEM [ZM]

Monitor item (Definition)	Unit/ Condition	Condition/Specification (Reference)	Action	PCM terminal
FAN3 (Cooling fan control)	ON/OFF	Cooling fan operating (ECT above 97 °C {207 °F}) or terminal TEN grounded and throttle valve open or A/C relay on: ON Others: OFF	Inspect following PIDs: RPM, TP, ECT, ACSW, TEST Inspect cooling fan relay (See 09-21-5 RELAY INSPECTION)	47
FP (Fuel pump relay)	ON/OFF	Ignition switch ON: OFF Idle: ON Cranking: ON	Inspect following PID: RPM Inspect fuel pump relay (See 09-21-5 RELAY INSPECTION)	80
FPRC (PRC solenoid valve)	ON/OFF	Ignition switch ON: OFF Idle: OFF After hot start: ON	Inspect PRC solenoid valve (See 01-14-31 PRC SOLENOID VALVE INSPECTION)	95
FTL V (Fuel tank level signal voltage)	V	Idle condition <ul style="list-style-type: none"> <li>Fuel tank full: 1.0—1.5 V</li> <li>Fuel tank empty: 4.4—4.8 V</li> <li>Fuel tank half: 2.8—3.4 V</li> </ul> <b>Note</b> <ul style="list-style-type: none"> <li>The voltages above will be measured when the battery positive voltage is between 12V and 14 V.</li> </ul>	Inspect fuel gauge sender unit (See 09-22-4 Fuel Gauge)	63
FTP (Fuel tank pressure)	kPa	Ignition switch ON: 0—1.0 kPa {0—0.3 inHg} Idle: 0—1.0 kPa {0—0.3 inHg}	Inspect fuel tank pressure sensor (See 01-40A-40 FUEL TANK PRESSURE SENSOR INSPECTION [ZM])	62
	inHg	<b>Note</b> <ul style="list-style-type: none"> <li>The pressure and output voltage varies according to the fuel temperature.</li> </ul>		
	V	Ignition switch ON: 2.5—2.8 V Idle: 2.5—2.8 V Fuel tank pressure 0 kPa {0 mmHg, 0 inHg}: 2.5 V Fuel tank pressure 1 kPa {7.5 mmHg, 0.3 inHg}: 2.8 V	Inspect fuel tank pressure sensor (See 01-40A-40 FUEL TANK PRESSURE SENSOR INSPECTION [ZM])	62
FTP1SV	kPa	Perform "DTC INSPECTION". (See 01-02A-15 DTC TABLE [ZM])		—
FTP2SV	kPa			
FUELPW1 (Fuel injection duration)	ms	Ignition switch ON: 0 msec Idle: 2.5—4.0 msec	Inspect following PIDs: MAF, IAT, RPM, TP, ECT, PNP, CPP, O2S11, PSP, BOO, ACSW, VPWR Inspect CMP sensor (See 01-40A-35 CAMSHAFT POSITION (CMP) SENSOR INSPECTION [ZM])	74, 75, 100, 101
GEAR (Gear position)	1/2/3/4	1GR: 1 2GR: 2 3GR: 3 4GR: 4	Inspect following PIDs: SSA/SS1, SSB/SS2, SSC/SS3, SSD/SS4, SSE/SS5	1, 27, 82, 99, 102
HTR11 (HO2S heater (Front))	ON/OFF	Ignition switch ON (engine stopped): OFF Approx. 15 seconds after engine start with ECT 20—30 °C {68—86°F}: ON Others: ON ⇔ OFF	Inspect following PIDs: ECT, MAF Inspect HO2S heater (See 01-40A-37 HO2S Heater (Front and Rear) Resistance Inspection)	94
HTR12 (HO2S heater (Rear))	ON/OFF	ECT above 70 °C {158 °F}: ON HO2S (Rear) heater is malfunctioning: OFF	Inspect following PIDs: ECT, MAF Inspect HO2S heater (See 01-40A-37 HO2S Heater (Front and Rear) Resistance Inspection)	93

01-40A

## CONTROL SYSTEM [ZM]

Monitor item (Definition)	Unit/ Condition		Condition/Specification (Reference)	Action	PCM terminal
IAC (IAC valve)	%		Ignition switch ON: 0% Idle: 25—35%	Inspect following PIDs: IAT, RPM, ECT, MAF, TP, PNP, CPP, PSP, ACSW, TEST Inspect IAC valve (See 01-13A-7 IDLE AIR CONTROL (IAC) VALVE INSPECTION [ZM])	54, 83
IAT (Intake air temperature)	°C	°F	IAT 20 °C {68 °F}: 20 °C {68 °F}	Inspect IAT sensor (See 01-40A-26 MASS AIR FLOW (MAF)/INTAKE AIR TEMPERATURE (IAT) SENSOR INSPECTION [ZM])	39
	V		IAT 20 °C {68 °F}: 2.3—2.4 V IAT 30 °C {86 °F}: 1.7—1.9 V	Inspect IAT sensor (See 01-40A-26 MASS AIR FLOW (MAF)/INTAKE AIR TEMPERATURE (IAT) SENSOR INSPECTION [ZM])	39
IMRC (VTCS solenoid valve)	ON/OFF		ECT above 65 °C {149 °F} while idling: OFF ECT below 65 °C {149 °F} and engine speed at 1,500 rpm: ON	Inspect following PIDs: ECT, RPM, TP Inspect VTCS solenoid valve (See 01-13A-11 VARIABLE TUMBLE CONTROL SYSTEM (VTCS) SOLENOID VALVE INSPECTION [ZM])	19
LOAD (Load)	%		Idle: 13—20% (MTX), 14—22% (ATX) Engine speed at 2,500 rpm: 11— 17% (MTX), 13—19% (ATX)	Perform "On-Board Diagnostic Test" (See 01-02A-8 ON-BOARD DIAGNOSTIC TEST [ZM])	—
LONGFT1 (Long fuel trim)	%		Idle: -5—5%	Perform "On-Board Diagnostic Test" (See 01-02A-8 ON-BOARD DIAGNOSTIC TEST [ZM])	—
LPS*1 (Pressure control solenoid)	A		Change current value according to throttle opening angle	Inspect pressure control solenoid (See 05-17-28 SOLENOID VALVES INSPECTION)	44, 81
MAF (Intake MAF)	g/s		Idle: 1.6—2.2 g/s (MTX), 1.6— 2.4 g/s (ATX) Engine speed at 2,500 rpm: 5.1— 6.5 g/s (MTX), 5.6—7.2 g/s (ATX)	Inspect MAF sensor (See 01-40A-26 MAF Sensor Inspection)	88
	V		Ignition switch ON: 0.6—2.0 V Idle: 0.8—2.2 V	Inspect MAF sensor (See 01-40A-26 MASS AIR FLOW (MAF)/INTAKE AIR TEMPERATURE (IAT) SENSOR INSPECTION [ZM])	88
MIL (Malfunction indicator light)	ON/OFF		Ignition switch ON: ON DTC output: ON No DTC output: OFF	Inspect MIL	2
MODE1 (Readiness Function Code)	ON/OFF		RFC exists: ON No RFC: OFF	—	—
O2S11 (HO2S (Front))	V		Ignition switch ON: 0—1.0 V After warm up: 0—1.0 V Acceleration: 0.5—1.0 V Deceleration: 0—0.5 V	Inspect HO2S (See 01-40A-36 HO2S (Front and Rear) Voltage Inspection)	60
O2S12 (HO2S (Rear))	V		Ignition switch ON: 0—1.0 V Idle (After warm up): 0—1.0 V Idle (Engine cold): 0—0.5 V Accelerate: 0.5—1.0 V Decelerate: 0—0.5 V	Inspect HO2S (See 01-40A-36 HO2S (Front and Rear) Voltage Inspection)	35
PNP*1 (TR switch)	ON/OFF		P or N range: ON Others: OFF	Inspect TR switch (See 05-17-20 TRANSAXLE RANGE (TR) SWITCH INSPECTION)	64
PNP*2 (Neutral switch)	ON/OFF		Shift position at neutral: ON Others: OFF	Inspect neutral switch (See 01-40A-42 NEUTRAL SWITCH INSPECTION [ZM])	64
PSP (PSP switch)	ON/OFF		Steering wheel is at straight ahead position: OFF Steering wheel is fully turned: ON	Inspect PSP switch (See 01-40A-43 POWER STEERING PRESSURE (PSP) SWITCH INSPECTION [ZM])	31

## CONTROL SYSTEM [ZM]

Monitor item (Definition)	Unit/ Condition	Condition/Specification (Reference)	Action	PCM terminal
RPM (Engine speed)	rpm	Idle: 650—750 rpm	Inspect CKP sensor (See 01-40A-32 CRANKSHAFT POSITION (CKP) SENSOR INSPECTION [ZM])	21, 22
SEGRP (EGR valve (stepping motor) position)	step	Ignition switch ON: 0 step Idle: 0 step Cranking: 0—60 steps	Inspect following PIDs: ECT, TP Inspect EGR valve (See 01-16-15 EGR VALVE INSPECTION)	46, 56, 68, 72
SHRTFT1 (Short fuel trim)	%	Idle: -10—10%	Perform "On-Board Diagnostic Test" (See 01-02A-8 ON-BOARD DIAGNOSTIC TEST [ZM])	—
SPARKADV (Ignition timing)	BTDC	Idle: BTDC 6—18° Idle (Terminal TEN ground): BTDC 9—11°	Inspect following PIDs: MAF, IAT, RPM, TP, ECT, PSP, PNP, CPP, ACSW, TEST Perform Engine tune-up. (See 01-10A-25 ENGINE TUNE-UP [ZM])	26, 52
SSA/SS1*1 (Shift solenoid A)	%	Fourth gear: 100% Others: 0%	Inspect shift solenoid A (See 05-17-28 SOLENOID VALVES INSPECTION)	82
SSB/SS2*1 (Shift solenoid B)	%	First gear: 100% Others: 0%	Inspect shift solenoid B (See 05-17-28 SOLENOID VALVES INSPECTION)	99
SSC/SS3*1 (Shift solenoid C)	%	First gear: 100% Second gear: 100% N position: ON Others: 0%	Inspect shift solenoid C (See 05-17-28 SOLENOID VALVES INSPECTION)	102
SSD/SS4*1 (Shift solenoid D)	ON/OFF	P or N position: ON 1 range: ON Others: OFF	Inspect shift solenoid D (See 05-17-28 SOLENOID VALVES INSPECTION)	27
SSE/SS5*1 (Shift solenoid E)	ON/OFF	TCC operating: ON 1 range: ON Others: OFF	Inspect shift solenoid E (See 05-17-28 SOLENOID VALVES INSPECTION)	1
TCIL (O/D OFF indicator light)	ON/OFF	O/D OFF mode: ON Others: OFF	Inspect O/D OFF indicator light	43
TCS (O/D OFF switch)	ON/OFF	O/D OFF switch pressed: ON Others: OFF	Inspect O/D OFF switch (See 05-17-19 O/D OFF SWITCH INSPECTION)	29
TEST (TEN terminal (DLC))	ON/OFF	Open terminal TEN: OFF Short terminal TEN: ON	Inspect DLC TEN terminal and PCM connector terminal 5	5
TFT*1 (Transaxle fluid temperature)	°C    °F	TFT 20 °C {68 °F}: 20 °C {68 °F} TFT 130 °C {266 °F}: 130 °C {266 °F}	Inspect TFT sensor (See 05-17-25 TRANSAXLE FLUID TEMPERATURE (TFT) SENSOR INSPECTION)	37
TFTV*1 (TFT sensor signal voltage)	V	TFT 20 °C {68 °F}: 3.4—3.6 V TFT 130 °C {266 °F}: 0.4—0.5 V	Inspect TFT sensor (See 05-17-25 TRANSAXLE FLUID TEMPERATURE (TFT) SENSOR INSPECTION)	37
TPOD*1 (TP)	%	CTP: 0% WOT: 100%	Inspect TP sensor (See 01-40A-28 THROTTLE POSITION (TP) SENSOR INSPECTION [ZM])	89
TP (TP sensor signal voltage)	V	CTP: 0.1—1.1 V WOT: 3.0—4.6 V	Inspect TP sensor (See 01-40A-28 THROTTLE POSITION (TP) SENSOR INSPECTION [ZM])	89
TRL <sup>1</sup> (TR switch [1range])	ON/OFF	1 range: ON Others: OFF	Inspect TR switch (See 05-17-20 TRANSAXLE RANGE (TR) SWITCH INSPECTION)	7
TROD*1 (TR switch [D range])	ON/OFF	D range: ON Others: OFF	Inspect TR switch (See 05-17-20 TRANSAXLE RANGE (TR) SWITCH INSPECTION)	6

01-40A

## CONTROL SYSTEM [ZM]

Monitor item (Definition)	Unit/ Condition	Condition/Specification (Reference)	Action	PCM terminal
TRR* <sup>1</sup> (TR switch [R position])	ON/OFF	R position: ON Others: OFF	Inspect TR switch (See 05-17-20 TRANSAXLE RANGE (TR) SWITCH INSPECTION)	32
TRD* <sup>1</sup> (TR switch [2range])	ON/OFF	2 range: ON Others: OFF	Inspect TR switch (See 05-17-20 TRANSAXLE RANGE (TR) SWITCH INSPECTION)	9
TSS* <sup>1</sup> (Input/turbine speed signal)	rpm	Ignition switch ON: 0 rpm Idle: 650—750 rpm	Inspect input/turbine speed sensor (See 05-17-20 TRANSAXLE RANGE (TR) SWITCH INSPECTION)	23, 84
VPWR (Battery positive voltage)	V	Ignition switch ON: B+	Inspect main relay (See 09-21-5 RELAY INSPECTION Inspect battery) (See 01-17-1 BATTERY INSPECTION)	71, 97
VSS (Vehicle speed)	km/h    mph	Vehicle speed 20 km/h {12.5 mph}; 20 km/h {12.5 mph} Vehicle speed 40 km/h {25 mph}; 40km/h {25 mph}	Inspect VSS MTX: (See 09-22-4 Speedometer) ATX: (See 05-17-27 VEHICLE SPEEDOMETER SENSOR (VSS) INSPECTION [ATX])	58

\*1 : ATX only

\*2 : MTX only

### PCM Inspection Using the SST (104 Pin Breakout Box)

1. Disconnect the negative battery cable.
2. Disconnect the PCM connector.
3. Connect the **SST** (104 Pin Breakout Box) to the PCM as shown.
4. Tighten the connector bolt.

#### Tightening torque

**7.9—10.7 N·m**

**{80—110 kgf·m, 69.5—95.4 in·lbf}**

5. Connect the negative battery cable.
6. Measure the voltage at each terminal.
  - If any incorrect voltage is detected, inspect the related system(s), wiring harnesses and connector(s) referring to the action column in the terminal voltage table.

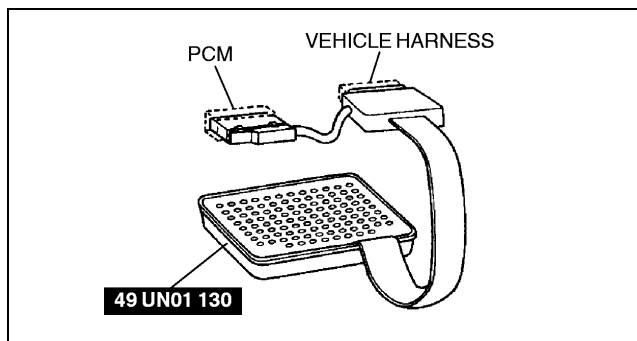

X3U140WA2

### Terminal voltage table (Reference)

Terminal	Signal	Connected to	Test condition	Voltage (V)	Action
1* <sup>1</sup>	Shift solenoid E control	Shift solenoid E	Idle (P position)	Below 1.0	<ul style="list-style-type: none"> <li>• Inspect shift solenoid E (See 05-17-28 SOLENOID VALVES INSPECTION)</li> <li>• Inspect related harness</li> </ul>
			1 range (1GR)	B+	
2	MIL control	MIL (in instrument cluster)	Ignition switch ON	Below 1.0	<ul style="list-style-type: none"> <li>• Inspect MIL</li> <li>• Inspect related harness</li> </ul>
			Idle	B+	
3	—	—	—	—	—
4	B+ monitor	Battery	Under any condition	B+	<ul style="list-style-type: none"> <li>• Inspect battery (See 01-17-1 BATTERY INSPECTION)</li> <li>• Inspect EGI fuse</li> <li>• Inspect related harness</li> </ul>

## CONTROL SYSTEM [ZM]

Terminal	Signal	Connected to	Test condition		Voltage (V)	Action
5	Diagnostic test mode	DLC terminal TEN	Ignition switch ON	Open terminal TEN	B+	<ul style="list-style-type: none"> <li>Inspect related harness</li> </ul>
				Short to ground terminal TEN	Below 1.0	
6	Clutch operation (MTX)	Clutch switch	Clutch pedal depressed		Below 1.0	<ul style="list-style-type: none"> <li>Inspect clutch switch (See 01-40A-41 CLUTCH SWITCH INSPECTION [ZM])</li> <li>Inspect related harness</li> </ul>
			Clutch pedal released		B+	
	D range (ATX)	TR switch (terminal G)	Ignition switch ON	Selector lever is at D range	B+	<ul style="list-style-type: none"> <li>Inspect TR switch (See 05-17-20 TRANSAXLE RANGE (TR) SWITCH INSPECTION)</li> <li>Inspect related harness</li> </ul>
				Selector lever is at other than D range	Below 1.0	
7*1	1 range	TR switch (terminal E)	Ignition switch ON	Selector lever is at 1 range	B+	<ul style="list-style-type: none"> <li>Inspect TR switch (See 05-17-20 TRANSAXLE RANGE (TR) SWITCH INSPECTION)</li> <li>Inspect related harness</li> </ul>
				Selector lever is at other than 1 range	Below 1.0	
8	—	—	—		—	—
9*1	2 range	TR switch (terminal F)	Ignition switch ON	Selector lever is at 2 range	B+	<ul style="list-style-type: none"> <li>Inspect TR switch (See 05-17-20 TRANSAXLE RANGE (TR) SWITCH INSPECTION)</li> <li>Inspect related harness</li> </ul>
				Selector lever is at other than 2 range	Below 1.0	
10	—	—	—		—	—
11	—	—	—		—	—
12	—	—	—		—	—
13	EPROM flashing	DLC-2 terminal FEPS	Because this terminal is for serial communication, good/no good judgment by terminal voltage is not possible.			<ul style="list-style-type: none"> <li>Inspect related harness</li> </ul>
14	—	—	—		—	—
15	—	—	—		—	—
16	—	—	—		—	—
17	—	—	—		—	—
18	CDCV control	CDCV	Ignition switch ON		B+	<ul style="list-style-type: none"> <li>Inspect CDCV (See 01-16-10 CANISTER DRAIN CUT VALVE (CDCV) INSPECTION)</li> <li>Inspect related harness</li> </ul>
			Diagnosis executed (while on-board device control is carrying out)		Below 1.0	
19	VTCS control	VTCS solenoid valve	ECT above 65 °C {149 °F} while idling		B+	<ul style="list-style-type: none"> <li>Inspect VTCS solenoid valve (See 01-13A-11 VARIABLE TUMBLE CONTROL SYSTEM (VTCS) SOLENOID VALVE INSPECTION [ZM])</li> <li>Inspect related harness</li> </ul>
			ECT below 65 °C {149 °F} and engine speed at 1,500 rpm		Below 1.0	
20	—	—	—		—	—

01-40A



## CONTROL SYSTEM [ZM]

Terminal	Signal	Connected to	Test condition		Voltage (V)	Action
21	NE (+)	CKP sensor	<ul style="list-style-type: none"> <li>Inspect using the wave profile. (See 01-40A-21 Inspection Using An Oscilloscope (Reference))</li> </ul>			<ul style="list-style-type: none"> <li>Inspect CKP sensor (See 01-40A-32 CRANKSHAFT POSITION (CKP) SENSOR INSPECTION [ZM])</li> <li>Inspect related harness</li> </ul>
22	NE (-)	CKP sensor	<ul style="list-style-type: none"> <li>Inspect using the wave profile. (See 01-40A-21 Inspection Using An Oscilloscope (Reference))</li> </ul>			<ul style="list-style-type: none"> <li>Inspect CKP sensor (See 01-40A-32 CRANKSHAFT POSITION (CKP) SENSOR INSPECTION [ZM])</li> <li>Inspect related harness</li> </ul>
23*1	Input/turbine speed (-)	Input/turbine speed sensor	<ul style="list-style-type: none"> <li>Inspect using the wave profile. (See 01-40A-21 Inspection Using An Oscilloscope (Reference))</li> </ul>			<ul style="list-style-type: none"> <li>Inspect input/turbine speed sensor (See 05-17-26 INPUT/TURBINE SPEED SENSOR INSPECTION)</li> <li>Inspect related harness</li> </ul>
24	GND	GND	Under any condition		Below 1.0	<ul style="list-style-type: none"> <li>Inspect related harness</li> </ul>
25	—	—	—		—	—
26	IGT1	Ignition coil (No. 1, 4 cylinders)	<ul style="list-style-type: none"> <li>Inspect using the wave profile. (See 01-40A-21 Inspection Using An Oscilloscope (Reference))</li> </ul>			<ul style="list-style-type: none"> <li>Inspect ignition coil (See 01-18-2 IGNITION COIL INSPECTION)</li> <li>Inspect related harness</li> </ul>
27*1	Shift solenoid D control	Shift solenoid D	Idle	Selector lever is at P, N position and 1 range	B+	<ul style="list-style-type: none"> <li>Inspect shift solenoid D (See 05-17-28 SOLENOID VALVES INSPECTION)</li> <li>Inspect related harness</li> </ul>
				Others	Below 1.0	
28*1	Vehicle speed output	Speedometer (in instrument cluster)	<ul style="list-style-type: none"> <li>Inspect using the wave profile. (See 01-40A-21 Inspection Using An Oscilloscope (Reference))</li> </ul>			<ul style="list-style-type: none"> <li>Inspect speedometer (See 09-22-4 Speedometer)</li> <li>Inspect related harness</li> </ul>
29*1	O/D OFF signal	O/D OFF switch	Ignition switch ON	O/D OFF switch pushed	Below 1.0	<ul style="list-style-type: none"> <li>Inspect O/D OFF switch (See 05-17-19 O/D OFF SWITCH INSPECTION)</li> <li>Inspect related harness</li> </ul>
				O/D OFF switch released	B+	
30	Generator output voltage	Generator (terminal P)	<ul style="list-style-type: none"> <li>Inspect using the wave profile. (See 01-40A-21 Inspection Using An Oscilloscope (Reference))</li> </ul>			<ul style="list-style-type: none"> <li>Inspect generator (See 01-17-3 GENERATOR INSPECTION)</li> <li>Inspect related harness</li> </ul>

## CONTROL SYSTEM [ZM]

Terminal	Signal	Connected to	Test condition	Voltage (V)	Action	
31	PSP	PSP switch	Ignition switch ON	B+	<ul style="list-style-type: none"> <li>Inspect PSP switch (See 01-40A-43 POWER STEERING PRESSURE (PSP) SWITCH INSPECTION [ZM])</li> <li>Inspect power steering system</li> <li>Inspect related harness</li> </ul>	
			Idle	Steering wheel at straight ahead position		B+
				While turning steering wheel		Below 1.0
32*1	R position	TR switch (terminal C)	Ignition switch ON	B+	<ul style="list-style-type: none"> <li>Inspect TR switch (See 05-17-20 TRANSAXLE RANGE (TR) SWITCH INSPECTION)</li> <li>Inspect related harness</li> </ul>	
			Selector lever is at other then R position	Below 1.0		
33	—	—	—	—	—	
34	BARO/EGR boost	EGR boost sensor	Ignition switch ON (Barometric pressure at 102 kPa {765 mmHg, 30 inHg})	Approx. 4.0	<ul style="list-style-type: none"> <li>Inspect EGR boost sensor (See 01-40A-38 EGR BOOST SENSOR INSPECTION [ZM])</li> <li>Inspect related harness</li> </ul>	
35	Catalytic converter efficiency	HO2S (Rear)	Ignition switch ON	Below 1.0	<ul style="list-style-type: none"> <li>Inspect HO2S (Rear) (See 01-40A-36 HO2S (Front and Rear) Voltage Inspection)</li> <li>Inspect related harness</li> </ul>	
			Idle	Engine cold		Approx. 0
				After warm up		0.1—0.9
36	—	—	—	—	—	
37*1	TFT	TFT sensor	Ignition switch ON	TFT 20 °C {68 °F}	3—4	<ul style="list-style-type: none"> <li>Inspect TFT sensor (See 05-17-25 TRANSAXLE FLUID TEMPERATURE (TFT) SENSOR INSPECTION)</li> <li>Inspect related harness</li> </ul>
			TFT 130 °C {266 °F}	0.2—0.7		
38	ECT	ECT sensor	Ignition switch ON	ECT 20 °C {68 °F}	2.9—3.1	<ul style="list-style-type: none"> <li>Inspect ECT sensor (See 01-40A-31 ENGINE COOLANT TEMPERATURE (ECT) SENSOR INSPECTION [ZM])</li> <li>Inspect related harness</li> </ul>
			After warm up	0.2—1.0		
39	IAT	IAT sensor (integrated with MAF sensor)	Ignition switch ON	IAT 20 °C {68 °F}	2.3—2.4	<ul style="list-style-type: none"> <li>Inspect IAT sensor (See 01-40A-27 IAT Sensor Resistance Inspection)</li> <li>Inspect related harness</li> </ul>
			IAT 30 °C {86 °F}	1.7—1.9		
40	—	—	—	—	—	
41	A/C on signal	Refrigerant pressure switch	Idle	A/C switch and fan switch on	Below 1.0	<ul style="list-style-type: none"> <li>Inspect A/C switch (See 07-40-9 REFRIGERANT PRESSURE SWITCH INSPECTION)</li> <li>Inspect related harness</li> </ul>
			A/C switch off	B+		

01-40A

## CONTROL SYSTEM [ZM]

Terminal	Signal	Connected to	Test condition	Voltage (V)	Action	
42	Generator warning light control	Generator warning light (in instrument cluster)	Ignition switch ON	Below 1.0	<ul style="list-style-type: none"> <li>Inspect generator warning light</li> <li>Inspect related harness</li> </ul>	
			Idle	B+		
43*1	O/D OFF indicator light signal	O/D OFF indicator light	Ignition switch ON	O/D OFF indicator light illuminates	Below 1.0	<ul style="list-style-type: none"> <li>Inspect O/D OFF indicator light</li> <li>Inspect related harness</li> </ul>
				O/D OFF indicator light does not illuminate	B+	
44*1	Pressure control solenoid control (+)	Pressure control solenoid	<ul style="list-style-type: none"> <li>Inspect using the wave profile. (See 01-40A-21 Inspection Using An Oscilloscope (Reference))</li> </ul>		<ul style="list-style-type: none"> <li>Inspect pressure control solenoid (See 05-17-28 SOLENOID VALVES INSPECTION)</li> <li>Inspect related harness</li> </ul>	
45	Condenser fan control	Condenser fan relay	Ignition switch ON		B+	<ul style="list-style-type: none"> <li>Inspect condenser fan relay (See 09-21-5 RELAY INSPECTION)</li> <li>Inspect related harness</li> </ul>
			Idle	Condenser fan operating	Below 1.0	
				Others	B+	
46	EGR valve #3 coil control	EGR valve (terminal B)	Ignition switch ON		B+	<ul style="list-style-type: none"> <li>Inspect EGR valve (See 01-16-15 EGR VALVE INSPECTION)</li> <li>Inspect related harness</li> </ul>
			Idle		B+	
47	Cooling fan control	Cooling fan relay	Ignition switch ON		B+	<ul style="list-style-type: none"> <li>Inspect cooling fan relay (See 09-21-5 RELAY INSPECTION)</li> <li>Inspect related harness</li> </ul>
			Idle	Cooling fan operating	Below 1.0	
				Others	B+	
48	Engine speed	Tachometer (in instrument cluster), DLC terminal IG-	<ul style="list-style-type: none"> <li>Inspect using the wave profile. (See 01-40A-21 Inspection Using An Oscilloscope (Reference))</li> </ul>		<ul style="list-style-type: none"> <li>Inspect tachometer (See 09-22-4 Tachometer)</li> <li>Inspect related harness</li> </ul>	
49	—	—	—	—	—	
50	—	—	—	—	—	
51	GND	GND	Under any condition	Below 1.0	<ul style="list-style-type: none"> <li>Inspect related harness</li> </ul>	
52	IGT2	Ignition coil (No. 2, 3 cylinders)	<ul style="list-style-type: none"> <li>Inspect using the wave profile. (See 01-40A-21 Inspection Using An Oscilloscope (Reference))</li> </ul>		<ul style="list-style-type: none"> <li>Inspect ignition coil (See 01-18-2 IGNITION COIL INSPECTION)</li> <li>Inspect related harness</li> </ul>	
53	Generator field coil control	Generator (terminal D)	<ul style="list-style-type: none"> <li>Inspect using the wave profile. (See 01-40A-21 Inspection Using An Oscilloscope (Reference))</li> </ul>		<ul style="list-style-type: none"> <li>Inspect generator (See 01-17-3 GENERATOR INSPECTION)</li> <li>Inspect related harness</li> </ul>	
54	IAC (+)	IAC valve	Ignition switch ON		B+	<ul style="list-style-type: none"> <li>Inspect IAC valve (See 01-13A-7 IDLE AIR CONTROL (IAC) VALVE INSPECTION [ZM])</li> <li>Inspect related harness</li> </ul>
			Idle (After warm up and E/L off)		B+	

## CONTROL SYSTEM [ZM]

Terminal	Signal	Connected to	Test condition	Voltage (V)	Action
55	Back-up power supply	Battery (positive terminal)	Under any condition	B+	<ul style="list-style-type: none"> <li>Inspect battery (See 01-17-1 BATTERY INSPECTION)</li> <li>Inspect EGI fuse</li> <li>Inspect related harness</li> </ul>
56	EGR valve #4 coil control	EGR valve (terminal F)	Ignition switch ON	Below 1.0	<ul style="list-style-type: none"> <li>Inspect EGR valve (See 01-16-15 EGR VALVE INSPECTION)</li> <li>Inspect related harness</li> </ul>
			Idle	Below 1.0	
57	—	—	—	—	—
58	Vehicle speed	Speedometer (MTX)	<ul style="list-style-type: none"> <li>Inspect using the wave profile. (See 01-40A-21 Inspection Using An Oscilloscope (Reference))</li> </ul>		<ul style="list-style-type: none"> <li>Inspect VSS (See 09-22-4 Speedometer)</li> <li>Inspect related harness</li> </ul>
		VSS (ATX)			<ul style="list-style-type: none"> <li>Inspect VSS (See 05-17-27 VEHICLE SPEEDOMETER SENSOR (VSS) INSPECTION [ATX])</li> <li>Inspect related harness</li> </ul>
59	—	—	—	—	—
60	HO2S (Front)	HO2S (Front)	Ignition switch ON	0—1.0	<ul style="list-style-type: none"> <li>Inspect HO2S (Front) (See 01-40A-36 HO2S (Front and Rear) Voltage Inspection)</li> <li>Inspect related harness</li> </ul>
			Idle	0—1.0	
			Acceleration	0.5—1.0	
			Deceleration	0—0.5	

01-40A

## CONTROL SYSTEM [ZM]

Terminal	Signal	Connected to	Test condition	Voltage (V)	Action
67	Purge control	Purge solenoid valve	<ul style="list-style-type: none"> <li>Inspect using the wave profile. (See 01-40A-21 Inspection Using An Oscilloscope (Reference))</li> </ul>		<ul style="list-style-type: none"> <li>Inspect purge solenoid valve (See 01-16-12 PURGE SOLENOID VALVE INSPECTION)</li> <li>Inspect related harness</li> </ul>
68	EGR valve #1 coil control	EGR valve (terminal E)	Ignition switch ON	Below 1.0	<ul style="list-style-type: none"> <li>Inspect EGR valve (See 01-16-15 EGR VALVE INSPECTION)</li> <li>Inspect related harness</li> </ul>
			Idle	Below 1.0	
69	—	—	—	—	—
70	—	—	—	—	—
71	Power supply	Main relay	Ignition switch ON	B+	<ul style="list-style-type: none"> <li>Inspect main relay (See 09-21-5 RELAY INSPECTION)</li> <li>Inspect EGI fuse</li> <li>Inspect related harness</li> </ul>
			Ignition switch off	Below 1.0	
72	EGR valve #2 coil control	EGR valve (terminal A)	Ignition switch ON	B+	<ul style="list-style-type: none"> <li>Inspect EGR valve (See 01-16-15 EGR VALVE INSPECTION)</li> <li>Inspect related harness</li> </ul>
			Idle	B+	
73	—	—	—	—	—
74	Fuel injection (#3)	Fuel injector No.3	<ul style="list-style-type: none"> <li>Inspect using the wave profile. (See 01-40A-21 Inspection Using An Oscilloscope (Reference))</li> </ul>		<ul style="list-style-type: none"> <li>Inspect fuel injector No.3 (See 01-14-24 FUEL INJECTOR INSPECTION)</li> <li>Inspect related harness</li> </ul>
75	Fuel injection (#1)	Fuel injector No.1	<ul style="list-style-type: none"> <li>Inspect using the wave profile. (See 01-40A-21 Inspection Using An Oscilloscope (Reference))</li> </ul>		<ul style="list-style-type: none"> <li>Inspect fuel injector No.1 (See 01-14-24 FUEL INJECTOR INSPECTION)</li> <li>Inspect related harness</li> </ul>
76	GND	GND	Under any condition	Below 1.0	<ul style="list-style-type: none"> <li>Inspect related harness</li> </ul>
77	GND	GND	Under any condition	Below 1.0	<ul style="list-style-type: none"> <li>Inspect related harness</li> </ul>
78	—	—	—	—	—
79	K-LINE (serial communication)	DLC terminal KLN	Because this terminal is for serial communication, good/no good judgment by terminal voltage is not possible.		<ul style="list-style-type: none"> <li>Inspect related harness</li> </ul>
80	Fuel pump control	Fuel pump relay	Ignition switch ON	B+	<ul style="list-style-type: none"> <li>Inspect fuel pump relay (See 09-21-5 RELAY INSPECTION)</li> <li>Inspect related harness</li> </ul>
			Cranking	Below 1.0	
			Idle	Below 1.0	
81*1	Pressure control solenoid (-) control	Pressure control solenoid	<ul style="list-style-type: none"> <li>Inspect using the wave profile. (See 01-40A-21 Inspection Using An Oscilloscope (Reference))</li> </ul>		<ul style="list-style-type: none"> <li>Inspect pressure control solenoid (See 05-17-28 SOLENOID VALVES INSPECTION)</li> <li>Inspect related harness</li> </ul>

## CONTROL SYSTEM [ZM]

Terminal	Signal	Connected to	Test condition	Voltage (V)	Action	
82*1	Shift solenoid A control	Shift solenoid A	<ul style="list-style-type: none"> <li>Inspect using the wave profile. (See 01-40A-21 Inspection Using An Oscilloscope (Reference))</li> </ul>		<ul style="list-style-type: none"> <li>Inspect shift solenoid A (See 05-17-28 SOLENOID VALVES INSPECTION)</li> <li>Inspect related harness</li> </ul>	
83	IAC (-)	IAC valve	<ul style="list-style-type: none"> <li>Inspect using the wave profile. (See 01-40A-21 Inspection Using An Oscilloscope (Reference))</li> </ul>		<ul style="list-style-type: none"> <li>Inspect IAC valve (See 01-13A-7 IDLE AIR CONTROL (IAC) VALVE INSPECTION [ZM])</li> <li>Inspect related harness</li> </ul>	
84*1	Input/turbine speed (+)	Input/turbine speed sensor	<ul style="list-style-type: none"> <li>Inspect using the wave profile. (See 01-40A-21 Inspection Using An Oscilloscope (Reference))</li> </ul>		<ul style="list-style-type: none"> <li>Inspect input/turbine speed sensor (See 05-17-26 INPUT/TURBINE SPEED SENSOR INSPECTION)</li> <li>Inspect related harness</li> </ul>	
85	SGC	CMP sensor	<ul style="list-style-type: none"> <li>Inspect using the wave profile. (See 01-40A-21 Inspection Using An Oscilloscope (Reference))</li> </ul>		<ul style="list-style-type: none"> <li>Inspect CMP sensor (See 01-40A-35 CAMSHAFT POSITION (CMP) SENSOR INSPECTION [ZM])</li> <li>Inspect related harness</li> </ul>	
86	—	—	—	—	—	
87	—	—	—	—	—	
88	MAF	MAF sensor	Ignition switch ON	0.9—2.0	<ul style="list-style-type: none"> <li>Inspect MAF sensor (See 01-40A-26 MASS AIR FLOW (MAF)/INTAKE AIR TEMPERATURE (IAT) SENSOR INSPECTION [ZM])</li> <li>Inspect related harness</li> </ul>	
			Idle	1.7—2.4		
89	Throttle position	TP sensor	Ignition switch ON	CTP	0.1—1.1	<ul style="list-style-type: none"> <li>Inspect TP sensor (See 01-40A-28 THROTTLE POSITION (TP) SENSOR INSPECTION [ZM])</li> <li>Inspect related harness</li> </ul>
				WOT	3.0—4.6	
90	Constant voltage (Vref)	TP sensor, EGR boost sensor, Fuel tank pressure sensor	Ignition switch ON	Approx. 5.0	<ul style="list-style-type: none"> <li>Inspect related harness</li> </ul>	
91	Sensor GND	ECT sensor, IAT sensor, EGR boost sensor, Fuel tank pressure sensor, TP sensor, HO2S (Front, Rear), TFT sensor	Under any condition	Below 1.0	<ul style="list-style-type: none"> <li>Inspect related harness</li> </ul>	
92	Brake	Brake switch	Brake pedal depressed	B+	<ul style="list-style-type: none"> <li>Inspect brake switch (See 04-11-5 BRAKE SWITCH INSPECTION)</li> <li>Inspect related harness</li> </ul>	
			Brake pedal released	Below 1.0		

01-40A

## CONTROL SYSTEM [ZM]

Terminal	Signal	Connected to	Test condition		Voltage (V)	Action
93	HO2S (Rear) heater control	HO2S (Rear)	Idle	ECT above 70°C {158 °F}	Below 1.0	<ul style="list-style-type: none"> <li>Inspect HO2S (Rear) (See 01-40A-37 HO2S Heater (Front and Rear) Resistance Inspection)</li> <li>Inspect related harness</li> </ul>
				HO2S (Rear) is malfunctioning	B+	
94	HO2S (Front) heater control	HO2S (Front)	Ignition switch ON (engine stopped)		B+	<ul style="list-style-type: none"> <li>Inspect HO2S (Front) heater. (See 01-40A-37 HO2S Heater (Front and Rear) Resistance Inspection)</li> <li>Inspect related harness</li> </ul>
			Approx. 15 seconds after engine start with ECT 20—30°C {68—86 °F}		Below 1.0	
			Others		Below 1.0 ↔ B+	
95	PRC	PRC solenoid valve	Ignition switch ON		B+	<ul style="list-style-type: none"> <li>Inspect PRC solenoid valve (See 01-14-31 PRC SOLENOID VALVE INSPECTION)</li> <li>Inspect related harness</li> </ul>
			After hot start		Below 1.0	
96	A/C control	A/C relay	Idle	A/C switch and fan switch on	Below 1.0	<ul style="list-style-type: none"> <li>Inspect A/C relay (See 09-21-5 RELAY INSPECTION)</li> <li>Inspect related harness</li> </ul>
				A/C switch off	B+	
97	Power supply	Main relay	Ignition switch ON		B+	<ul style="list-style-type: none"> <li>Inspect main relay (See 09-21-5 RELAY INSPECTION)</li> <li>Inspect related harness</li> </ul>
			Ignition switch off		Below 1.0	
98	EGR boost sensor switching control	EGR boost solenoid valve	Ignition switch ON		B+	<ul style="list-style-type: none"> <li>Inspect EGR boost solenoid valve (See 01-16-17 EGR BOOST SENSOR SOLENOID VALVE INSPECTION)</li> <li>Inspect related harness</li> </ul>
			Idle		B+	
99*1	Shift solenoid B control	Shift solenoid B	<ul style="list-style-type: none"> <li>Inspect using the wave profile. (See 01-40A-21 Inspection Using An Oscilloscope (Reference))</li> </ul>			<ul style="list-style-type: none"> <li>Inspect shift solenoid B (See 05-17-28 SOLENOID VALVES INSPECTION)</li> <li>Inspect related harness</li> </ul>
100	Fuel injection (#4)	Fuel injector No.4	<ul style="list-style-type: none"> <li>Inspect using the wave profile. (See 01-40A-21 Inspection Using An Oscilloscope (Reference))</li> </ul>			<ul style="list-style-type: none"> <li>Inspect fuel injector No.4 (See 01-14-24 FUEL INJECTOR INSPECTION)</li> <li>Inspect related harness</li> </ul>
101	Fuel injection (#2)	Fuel injector No.2	<ul style="list-style-type: none"> <li>Inspect using the wave profile. (See 01-40A-21 Inspection Using An Oscilloscope (Reference))</li> </ul>			<ul style="list-style-type: none"> <li>Inspect fuel injector No.2 (See 01-14-24 FUEL INJECTOR INSPECTION)</li> <li>Inspect related harness</li> </ul>

# CONTROL SYSTEM [ZM]

Terminal	Signal	Connected to	Test condition	Voltage (V)	Action
102*1	Shift solenoid C Control	Shift solenoid C	<ul style="list-style-type: none"> <li>Inspect using the wave profile. (See 01-40A-21 Inspection Using An Oscilloscope (Reference))</li> </ul>		<ul style="list-style-type: none"> <li>Inspect shift solenoid C (See 05-17-28 SOLENOID VALVES INSPECTION)</li> <li>Inspect related harness</li> </ul>
103	GND	GND	Under any condition	Below 1.0	<ul style="list-style-type: none"> <li>Inspect related harness</li> </ul>
104	—	—	—	—	—

01-40A

\*1 : ATX only

### Inspection Using An Oscilloscope (Reference)

#### Ne signal

- PCM terminal: 21(+)-22(-)
- Oscilloscope setting: 2 V/DIV(Y), 2ms/DIV(X), AC range
- Vehicle condition: idle after warm up

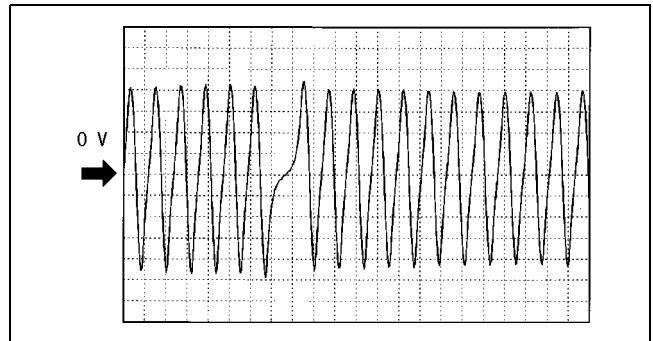

Z3U0140W006

#### IGT signal

- PCM terminal:
  - IGT1: 26(+)-103(-)
  - IGT2: 52(+)-103(-)
- Oscilloscope setting: 1 V/DIV(Y), 10ms/DIV(X), DC range
- Vehicle condition: idle after warm up

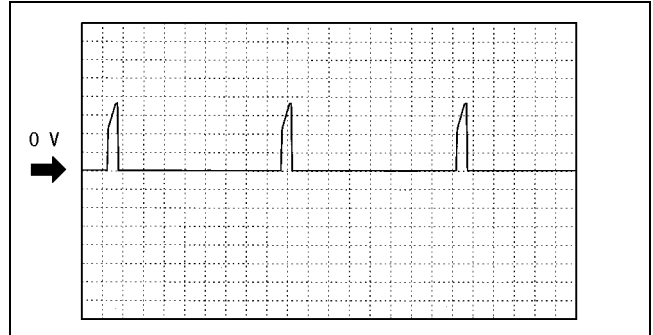

Z3U0140W007

#### Input/turbine speed signal

- PCM terminal: 84(+)-23(-)
- Oscilloscope setting: 0.4 V/DIV(Y), 2.5 ms/DIV(X), DC range
- Vehicle condition: idle after warm up

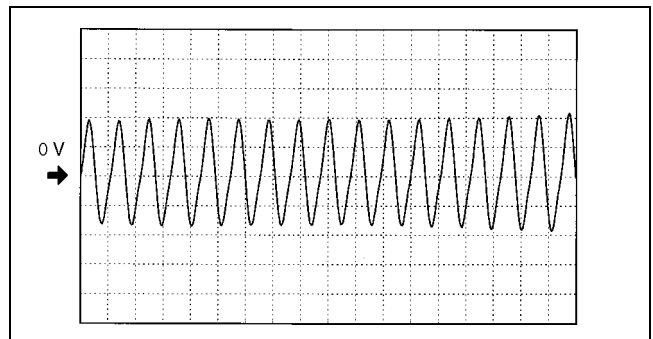

Z3U0140W008



# CONTROL SYSTEM [ZM]

## Generator output voltage signal

- PCM terminal: 30(+)-103(-)
- Oscilloscope setting: 2 V/DIV(Y), 5 ms/DIV(X), DC range
- Vehicle condition: idle after warm up

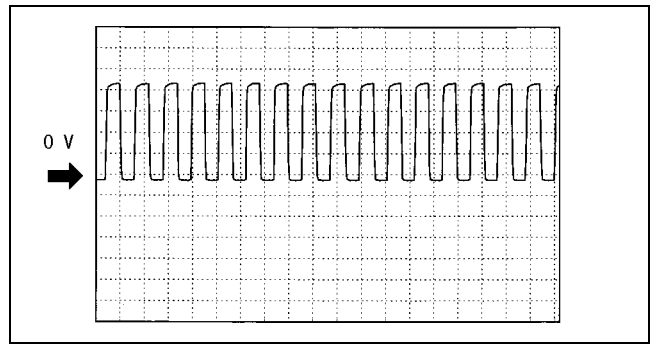

Z3U0140W009

## Pressure control solenoid control signal CTP

- PCM terminal: 80(+)-103(-)
- Oscilloscope setting: 0.5 V/DIV(Y), 0.1 ms/DIV(X), DC range
- Vehicle condition: ignition key at ON (Engine OFF) and closed throttle position.

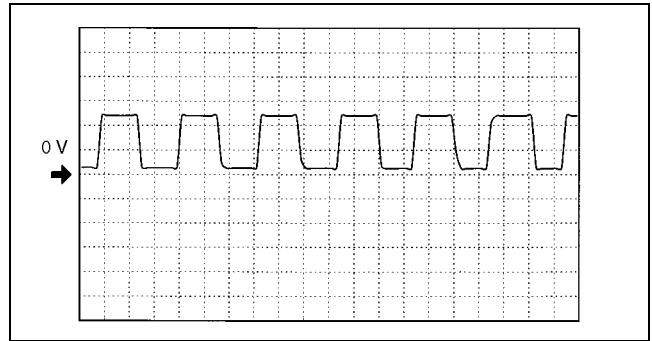

Z3U0140W010

## WOT

- PCM terminal: 81(+)-103(-)
- Oscilloscope setting: 0.5 V/DIV(Y), 0.1 ms/DIV(X), DC range
- Vehicle condition: ignition key at ON (Engine OFF) and wide open throttle

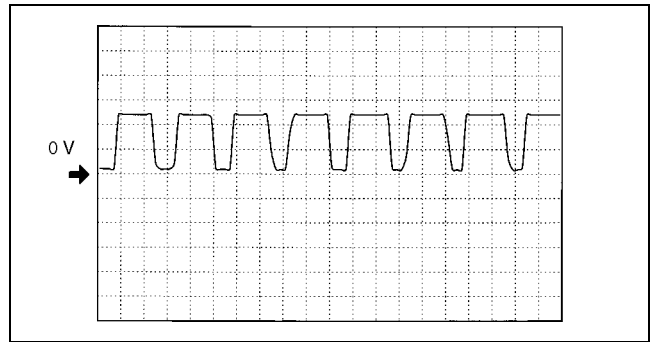

Z3U0140W019

## Engine speed signal

- PCM terminal: 48(+)-103(-)
- Oscilloscope setting: 2 V/DIV(Y), 20 ms/DIV(X), DC range
- Vehicle condition: idle after warm up

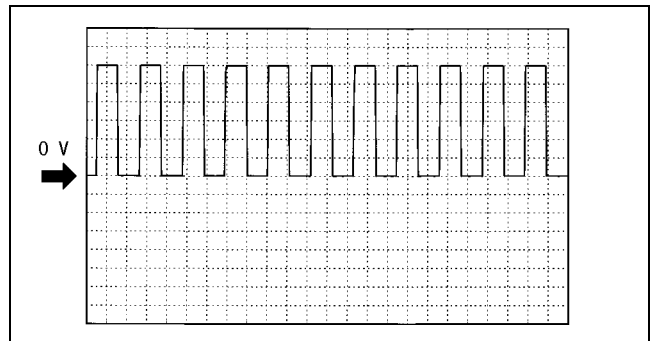

Z3U0140W011

## Generator field coil control signal

- PCM terminal: 53(+)-103(-)
- Oscilloscope setting: 0.2 V/DIV(Y), 2ms/DIV(X), DC range
- Vehicle condition: idle after warm up

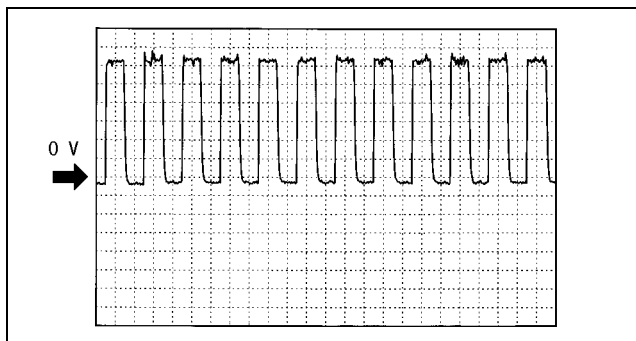

Z3U0140W012

01-40A

## Vehicle speed signal

- PCM terminal: 58(+)-103(-)
- Oscilloscope setting: 1 V/DIV(Y), 2.5 ms/DIV(X), DC range
- Vehicle condition: drive the vehicle with 32 km/h [20 mph]

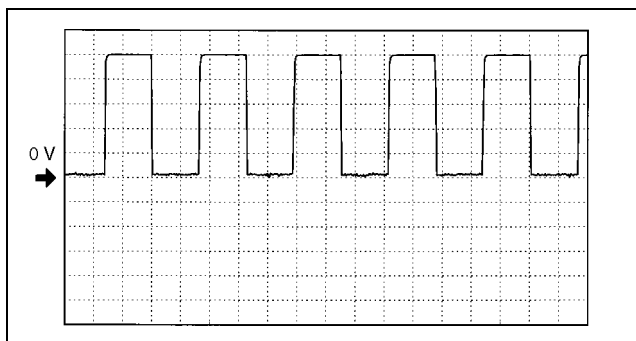

Z3U0140W013

## Purge control signal

- PCM terminal: 67(+)-103(-)
- Oscilloscope setting: 4 V/DIV(Y), 20 ms/DIV(X), DC range
- Vehicle condition: idle after warm up

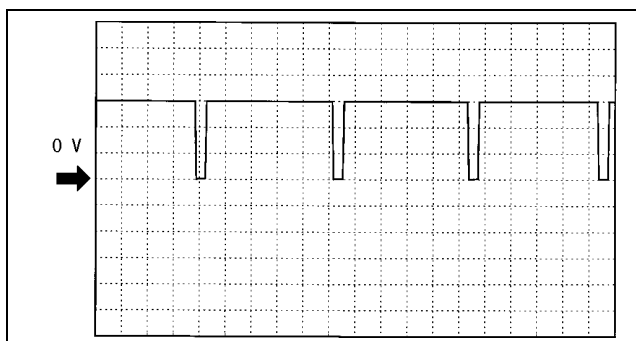

Z3U0140W014

## Fuel injection signal

- PCM terminal
  - No.1:75(+)-103(-)
  - No.2:101(+)-103(-)
  - No.3:74(+)-103(-)
  - No.4:100(+)-103(-)
- Oscilloscope setting: 2 V/DIV(Y), 5 ms/DIV(X), DC range
- Vehicle condition: idle after warm up

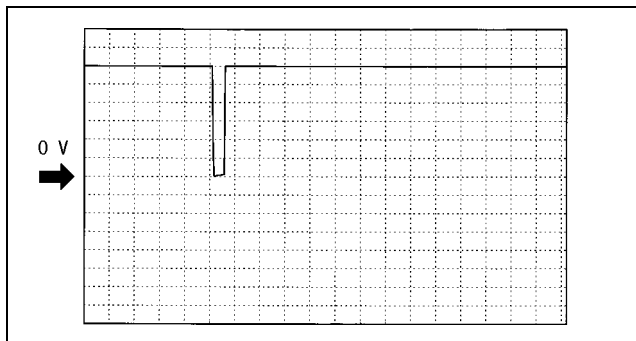

Z3U0140W015

# CONTROL SYSTEM [ZM]

## Shift solenoid A control

- PCM terminal: 82(+)-103(-)
- Oscilloscope setting: 5 V/DIV(Y), 5 ms/DIV(X), DC range
- Vehicle condition: drive in the 4th gear

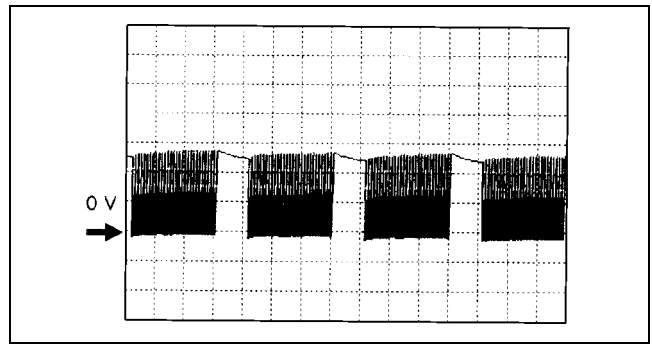

Z3U0140W016

## IAC signal

- PCM terminal: 83(+)-103(-)
- Oscilloscope setting: 2 V/DIV(Y), 0.5 ms/DIV(X), DC range
- Vehicle condition: idle after warm up

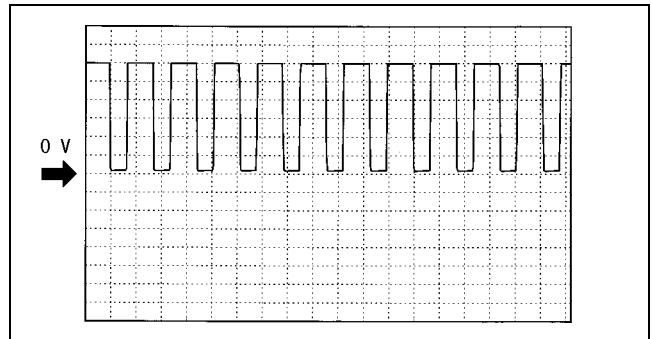

Z3U0140W017

## SGC signal

- PCM terminal: 85(+)-103(-)
- Oscilloscope setting: 2 V/DIV(Y), 20 ms/DIV(X), DC range
- Vehicle condition: idle after warm up

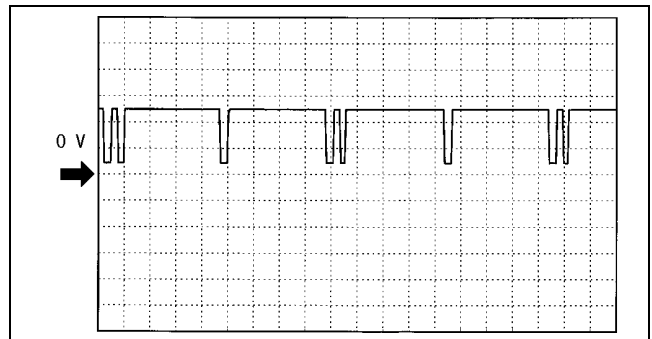

Z3U0140W018

## Shift solenoid B control signal

- PCM terminal: 99(+)-103(-)
- Oscilloscope setting: 5 V/DIV(Y), 5ms/DIV(X), DC range
- Vehicle condition: Drive in D range, 1st gear

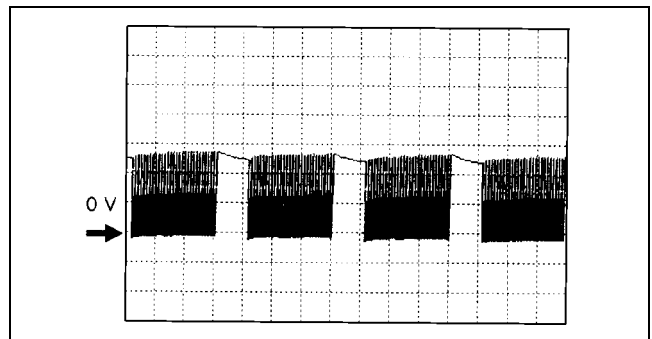

Z3U0140W016

## Shift solenoid C control signal

- PCM terminal: 102(+)-103(-)
- Oscilloscope setting: 5 V/DIV(Y), 5 ms/DIV(X), DC range
- Vehicle condition: Drive in 1st or 2nd gear

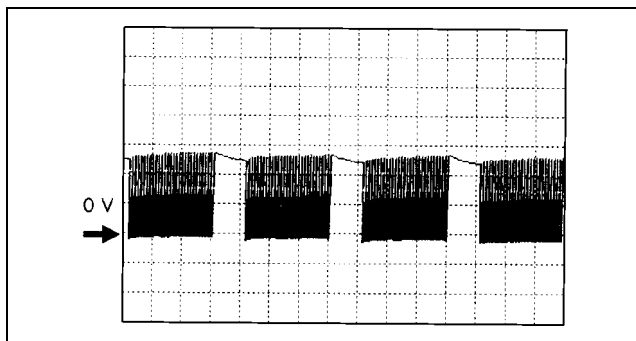

Z3U0140W016

01-40A

## INSPECTION USING AN OSCILLOSCOPE (REFERENCE) [ZM]

A3U014018881W08

### Note

- “INSPECTION USING AN OSCILLOSCOPE (REFERENCE)” is a general inspection for the following output devices.
  - Fuel injector
  - Purge solenoid valve
  - PRC solenoid valve
  - VTCS solenoid valve
  - EGR boost sensor solenoid valve

### Purpose

1. The use of oscilloscope makes the inspection of a part such as a stuck solenoid valve possible without actually removing parts.

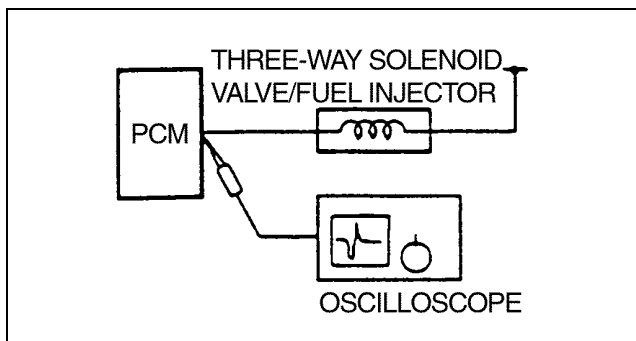

YLU140WBT

### When normal

1. Counter electromotive voltage A, generated when the three-way solenoid valve or the fuel injector is turned off from on, shows irregular convergence because induced electromotive voltage B, generated by the plunger return operation, is added to it.

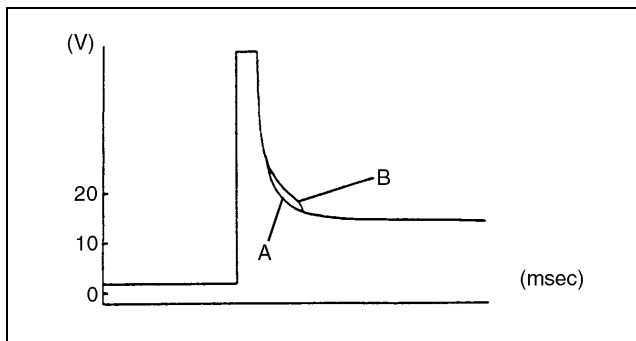

Y3U140WAA

# CONTROL SYSTEM [ZM]

## When plunger stuck

1. When the plunger is stuck, pulse convergence is smooth because no induced electromotive voltage B is generated.

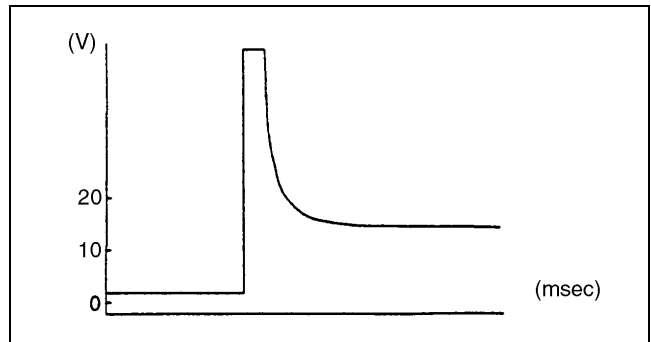

YLU140WBV

## MASS AIR FLOW (MAF)/INTAKE AIR TEMPERATURE (IAT) SENSOR INSPECTION [ZM]

A3U014013200W01

### Note

- Perform the following test only when directed.

### MAF Sensor Inspection

1. Visually inspect for damage, cracks, terminal bends and terminal rust on the MAF sensor.
  - If any of the above are found, replace the MAF sensor.
  - If the MAF sensor PID value or PCM terminal 88 voltage are out of specification, carry out the "Circuit Open/Short Inspection".

### Circuit Open/Short Inspection

1. Disconnect the PCM connector. (See 01-40A-7 PCM REMOVAL/INSTALLATION [ZM].)
2. Connect the **SST** (104 Pin Breakout Box) to the PCM as shown.
3. Tighten the connector attaching screw.

### Tightening torque

7.9—10.7 N·m

{80—110 kgf·cm, 69.5—95.4 in·lbf}

4. Inspect for an open or short circuit in the following wiring harnesses by probing the applicable sensor and **SST** (104 Pin Breakout Box) terminals with ohmmeter leads.
  - If there is an open or short circuit, repair or replace wiring harnesses.
  - If there is no open or short circuit, replace the MAF sensor.

### Open circuit

- MAF signal circuit (MAF sensor connector terminal C and PCM connector terminal 88)
- Power circuit (MAF sensor connector terminal A and main relay terminal D through common connector)
- GND circuit (MAF sensor connector terminal B and PCM connector terminal 77 through common connector)

### Short circuit

- MAF signal circuit (MAF sensor connector terminal C and PCM connector terminal 88 to GND)
- Power circuit (MAF sensor connector terminal A and main relay terminal D through common connector to GND)

5. Reconnect the MAF sensor connector.

### Note

- The scan tool shows the MAF rate and load value.

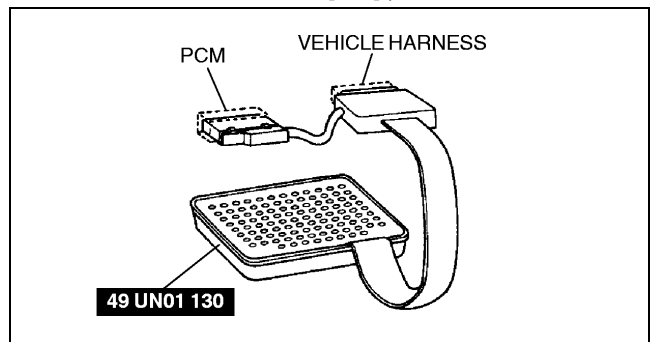

X3U140WBN

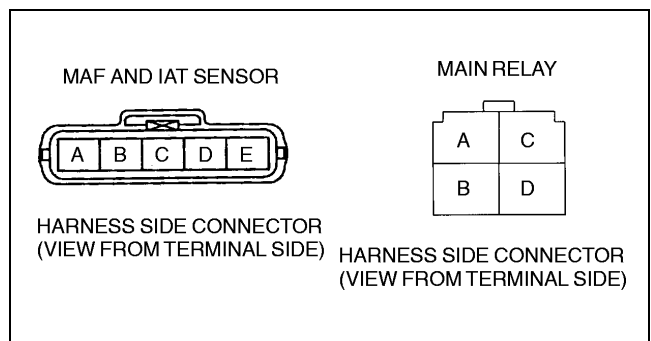

X3U140WA3

## Specification

	Intake MAF (g/s)		Engine load calculated value (%)	
	MTX	ATX	MTX	ATX
Idle*1	1.6—2.2	1.6—2.4	13.0— 20.0	14.0— 22.0
Engine speed 2,500 rpm*2	5.1—6.5	5.6—7.2	11.0— 17.0	13.0— 19.0

\*1 : 650—750 rpm

\*2 : No load, neutral or P position

## IAT Sensor Resistance Inspection

1. Disconnect the MAF sensor connector.
2. Measure the resistance between MAF sensor terminals D and E using an ohmmeter.
  - If not as specified, replace the MAF sensor.
  - If IAT sensor is okay, but PID value or PCM terminal 39 voltage are out of specification, carry out the "Circuit Open/Short Inspection".

## Specification

Ambient temperature (°C {°F})	Resistance (kilohm)
10 {50}	3.1—4.4
20 {68}	2.2—2.7
30 {86}	1.4—1.9

## IAT sensor signal characteristic (reference)

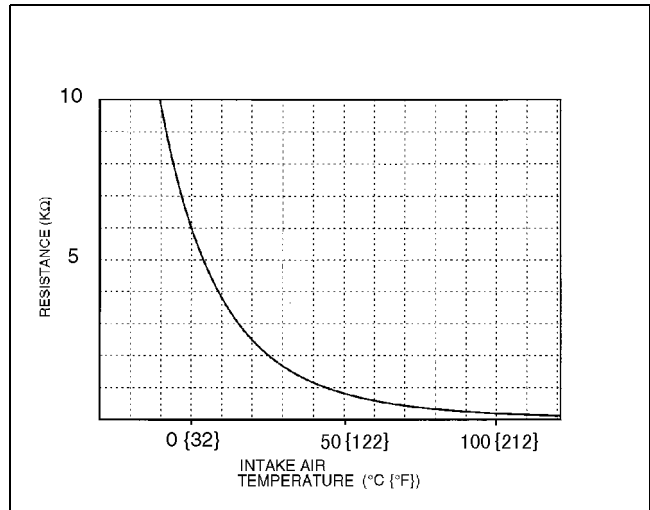

Z3U0140W021

## CONTROL SYSTEM [ZM]

### Circuit Open/Short Inspection

1. Remove the PCM. (See 01–40A–7 PCM REMOVAL/INSTALLATION [ZM].)
2. Connect the **SST** (104 Pin Breakout Box) to the PCM as shown.
3. Tighten the connector attaching screw.

#### Tightening torque

7.9–10.7 N·m

{80–110 kgf·cm, 69.5–95.4 in·lbf}

4. Inspect for an open or short circuit in the following wiring harnesses by probing the applicable sensor and **SST** (104 Pin Breakout Box) terminals with ohmmeter leads.

- If there is an open or short circuit, repair or replace wiring harnesses.
- If there is no open or short circuit, replace the MAF sensor.

#### Open circuit

- IAT signal circuit (MAF sensor connector terminal D and PCM connector terminal 39)
- GND circuit (MAF sensor connector terminal E and PCM connector terminal 91 through common connector)

#### Short circuit

- IAT signal circuit (MAF sensor connector terminal D and PCM connector terminal 39 to GND)

5. Reconnect the sensor connector.

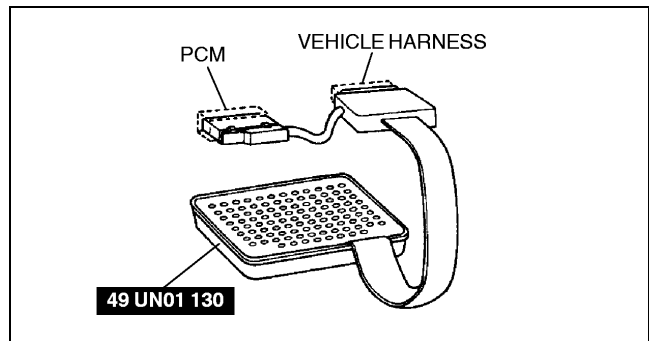

X3U140WBN

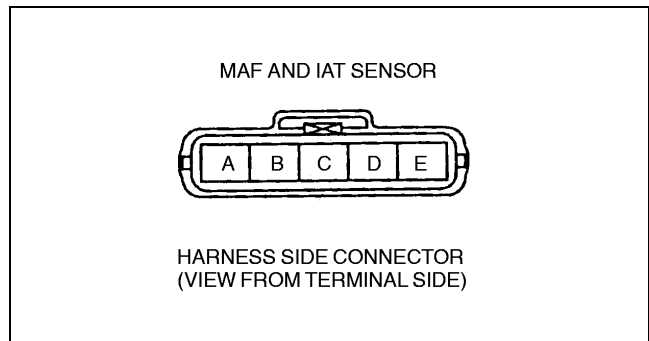

X3U140WA4

### THROTTLE POSITION (TP) SENSOR INSPECTION [ZM]

A3U014018910W02

#### Note

- The TP sensor on this type of vehicle is a maintenance-free type.
- Perform the following test only when directed.

### Resistance Inspection

1. Verify that the throttle valve is at CTP.
2. Inspect accelerator cable free play. (See 01–13A–13 ACCELERATOR CABLE INSPECTION/ADJUSTMENT [ZM].)
3. Measure the resistance between TP sensor terminals A and C using an ohmmeter.
  - If not as specified, replace the TP sensor.
  - If as specified, but PID value or PCM terminal 89 voltage is out of specification, carry out the “Circuit Open/Short Inspection”.

#### Specification

2.5–6 kilohms

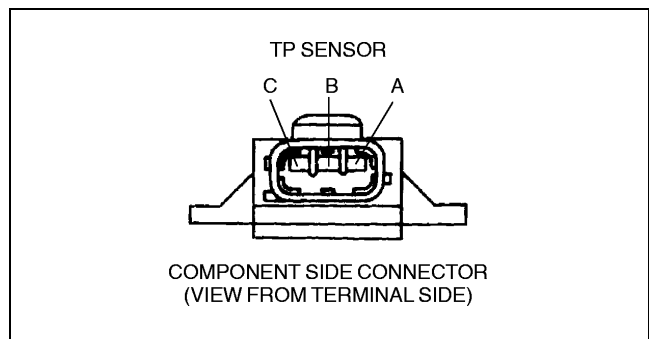

X3U140WA5

## Circuit Open/Short Inspection

1. Remove the PCM. (See 01-40A-7 PCM REMOVAL/INSTALLATION [ZM].)
2. Connect the **SST** (104 Pin Breakout Box) to the PCM as shown.
3. Tighten the connector attaching screw.

### Tightening torque

7.9—10.7 N·m

{80—110 kgf·cm, 69.5—95.4 in·lbf}

4. Inspect for an open or short circuit in the following wiring harnesses by probing the applicable sensor and **SST** (104 Pin Breakout Box) terminals with ohmmeter leads.
  - If there is an open or short circuit, repair or replace wiring harnesses.
  - If there is no open or short circuit, replace the TP sensor.

### Open circuit

- Constant voltage circuit (TP sensor connector terminal A and PCM connector terminal 90)
- TP signal circuit (TP sensor connector terminal C and PCM connector terminal 89)
- GND circuit (TP sensor connector terminal B and PCM connector terminal 91)

### Short circuit

- Constant voltage circuit (TP sensor connector terminal A and PCM connector terminal 90 to GND)
- TP signal circuit (TP sensor connector terminal C and PCM connector terminal 89 to GND)

5. Reconnect the TP sensor connector.

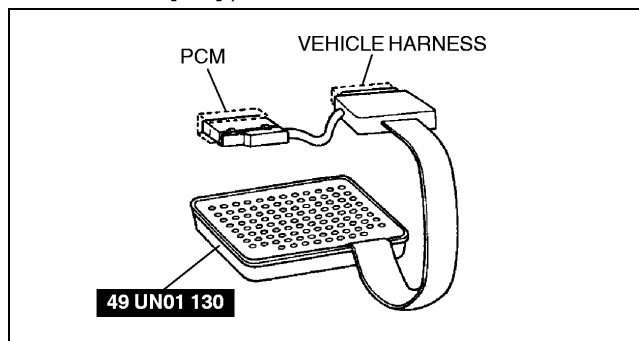

X3U140WBN

01-40A

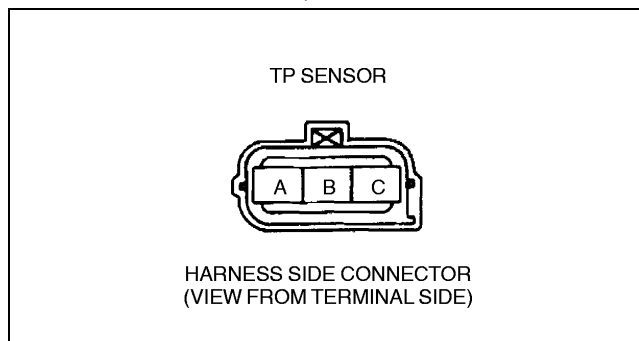

X3U140WA6



## CONTROL SYSTEM [ZM]

### THROTTLE POSITION (TP) SENSOR REMOVAL/INSTALLATION [ZM]

A3U014018910W03

1. Disconnect the TP sensor connector.
2. Remove the TP sensor screws.
3. Remove the TP sensor from the throttle body.
4. Verify that the throttle valve is fully closed.
5. Install the TP sensor to the throttle body.
6. Tighten the TP sensor screws.

#### Tightening torque

1.6—2.3 N·m {16—24 kgf·cm, 14—20 in·lbf}

7. Verify that the throttle valve moves smoothly.
8. Reconnect the TP sensor connector.

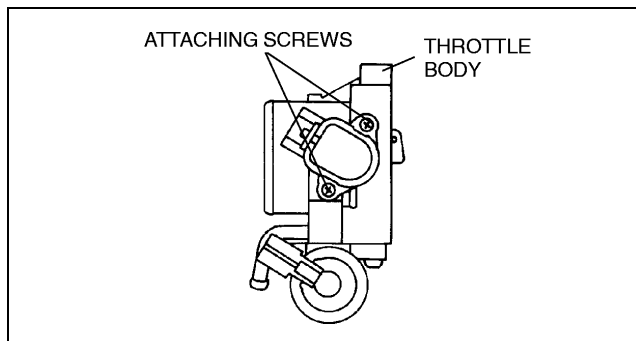

X3U140WA7

### ENGINE COOLANT TEMPERATURE (ECT) SENSOR REMOVAL/INSTALLATION [ZM]

A3U014018840W03

#### Warning

- When the engine is hot, it can badly burn. Turn off the engine and wait until it is cool before removing or installing the ECT sensor.

1. Drain the engine coolant. (See 01-12-2 COOLING SYSTEM SERVICE WARNINGS.) (See 01-12-3 ENGINE COOLANT REPLACEMENT.)
2. Disconnect the ECT sensor connector.
3. Remove the ECT sensor.
4. Replace the gasket.
5. Install in the reverse order of removal.
6. Refill the engine coolant. (See 01-12-2 COOLING SYSTEM SERVICE WARNINGS.) (See 01-12-3 ENGINE COOLANT REPLACEMENT.)

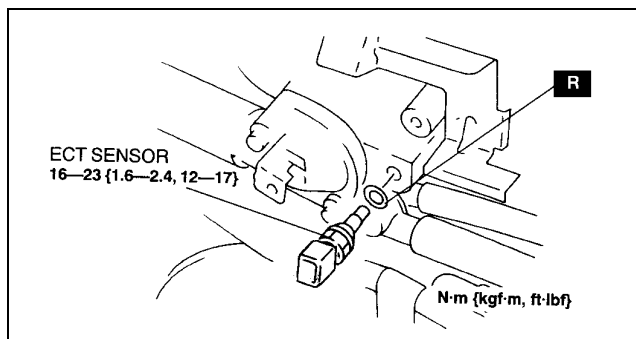

Y3U140WA1

**Note**

- Perform the following test only when directed.

**ECT Sensor Resistance Inspection**

1. Drain the engine coolant. (See 01-12-2 COOLING SYSTEM SERVICE WARNINGS.) (See 01-12-3 ENGINE COOLANT REPLACEMENT.)
2. Remove the ECT sensor.
3. Place the ECT sensor in water with a thermometer, and heat the water gradually.
4. Measure the resistance between the ECT sensor terminals A and B using an ohmmeter.
  - If not as specified, replace the ECT sensor.
  - If the ECT sensor is okay, but PID value or PCM terminal 38 voltage are out of specification, carry out the "Circuit Open/Short Inspection".

**Specification**

Water temperature (°C {°F})	Resistance (kilohm)
20 {68}	2.2—2.6
80 {176}	0.29—0.34

01-40A

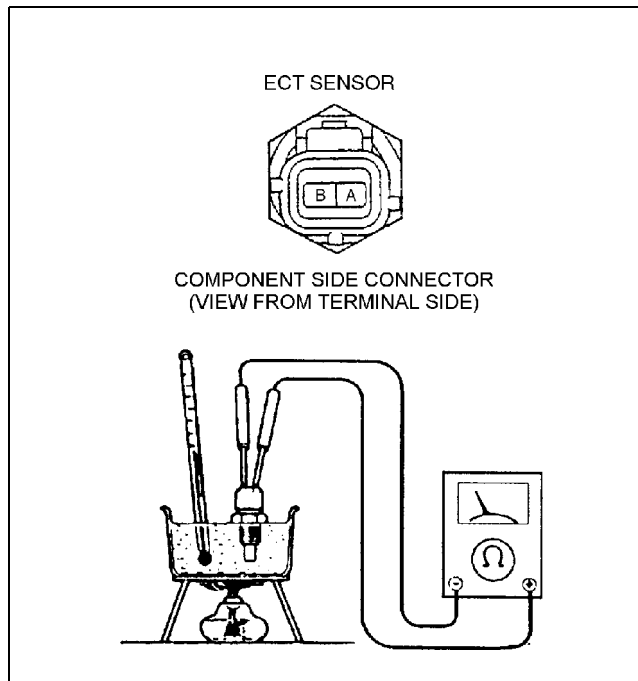

Z3U0140W025

**ECT sensor signal characteristic (reference)**

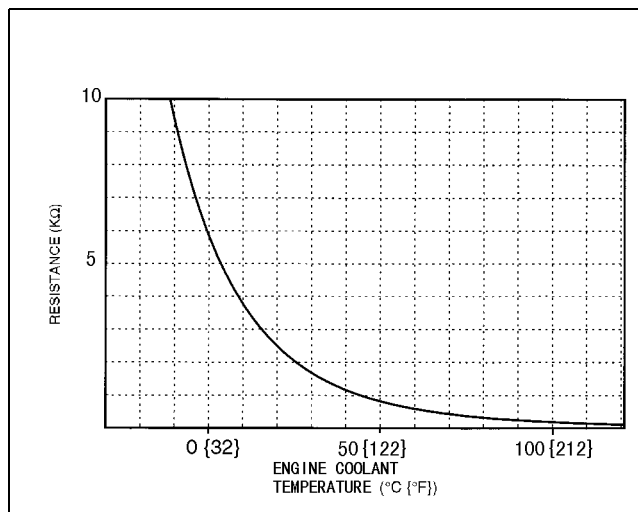

Z3U0140W022

## CONTROL SYSTEM [ZM]

### Circuit Open/Short Inspection

1. Remove the PCM. (See 01-40A-7 PCM REMOVAL/INSTALLATION [ZM].)
2. Connect the **SST** (104 Pin Breakout Box) to the PCM as shown.
3. Tighten the connector attaching screw.

#### Tightening torque

16—23 N·m

{1.6—2.4 kgf·m, 12—17 ft·lbf}

4. Inspect for an open or short circuit in the following wiring harnesses by probing the applicable sensor and **SST** (104 Pin Breakout Box) terminals with ohmmeter leads.

- If there is an open or short circuit, repair or replace wiring harnesses.
- If there is no open or short circuit, replace the ECT sensor.

#### Open circuit

- ECT signal circuit (ECT sensor connector terminal A and PCM connector terminal 38 through common connector)
- GND circuit (ECT sensor connector terminal B and PCM connector terminal 91)

#### Short circuit

- ECT signal circuit (ECT sensor connector terminal A and PCM connector terminal 38 to GND)
- GND circuit (ECT sensor connector terminal B and PCM connector terminal 91 to GND)

5. Install the ECT sensor.

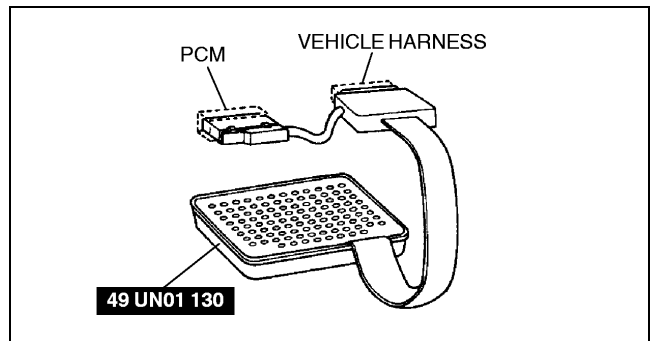

X3U140WBN

#### ECT SENSOR

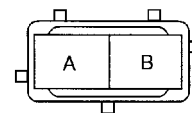

HARNESS SIDE CONNECTOR  
(VIEW FROM TERMINAL SIDE)

Z3U0140W026

### CRANKSHAFT POSITION (CKP) SENSOR INSPECTION [ZM]

A3U014018230W03

#### Air Gap Inspection

##### Note

- Perform the following test only when directed.

1. Verify that the CKP sensor is installed properly.
2. Measure the air gap between the plate teeth and the CKP sensor using a feeler gauge.
  - If not as specified, adjust the CKP sensor or inspect the plate teeth for being twisted and/or chipped.
  - If any of the plate teeth is twisted and/or chipped, replace the plate. (See 01-40A-34 PLATE REMOVAL/INSTALLATION [ZM].)

#### Specification

0.5—1.5 mm {0.020—0.059 in}

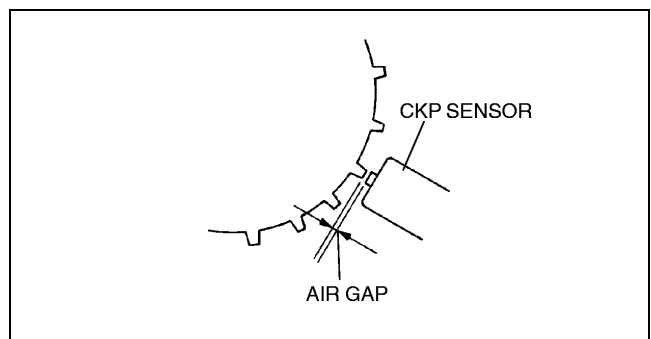

X3U140WAB

## Resistance Inspection

1. Disconnect the CKP sensor connector.
2. Measure the resistance between CKP sensor terminals A and B using an ohmmeter.
  - If not as specified, replace the CKP sensor.
  - If CKP sensor resistance is okay, but PID value or PCM terminal 21 and 22 voltage are out of specification, carry out the "Circuit Open/Short Inspection".

### Specification

**Approx. 550 ohms**

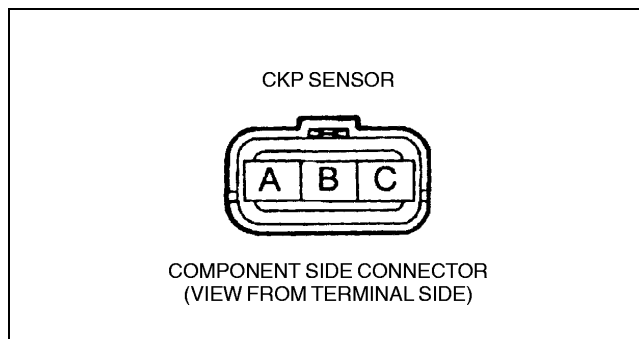

X3U140WBT

01-40A

## Circuit Open/Short Inspection

1. Remove the PCM. (See 01-40A-7 PCM REMOVAL/INSTALLATION [ZM].)
2. Connect the **SST** (104 Pin Breakout Box) to the PCM as shown.
3. Tighten the connector attaching screw.

### Tightening torque

**7.9—10.7 N·m**

**{80—110 kgf·cm, 69.5—95.4 in·lbf}**

4. Inspect for an open or short circuit in the following wiring harnesses by probing the applicable sensor and **SST** (104 Pin Breakout Box) terminals with ohmmeter leads.
  - If there is an open or short circuit, repair or replace wiring harnesses.
  - If there is no open or short circuit, replace the CKP sensor.

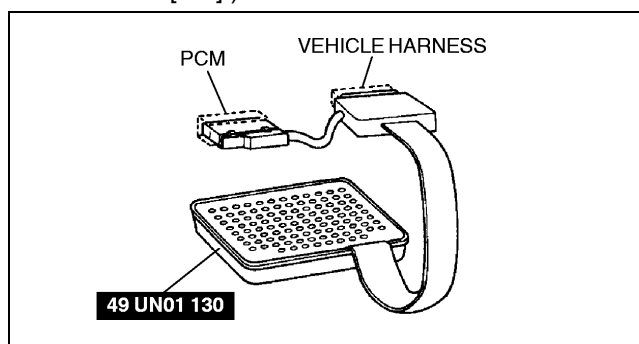

X3U140WBN

### Open circuit

- CKP signal (+) circuit (CKP sensor connector terminal A and PCM connector terminal 21)
- CKP signal (-) circuit (CKP sensor connector terminal B and PCM connector terminal 22)

### Short circuit

- CKP signal (+) circuit (CKP sensor connector terminal A and PCM connector 21 to GND)
- CKP signal (-) circuit (CKP sensor connector terminal B and PCM connector terminal 22)

5. Reconnect the CKP sensor connector.

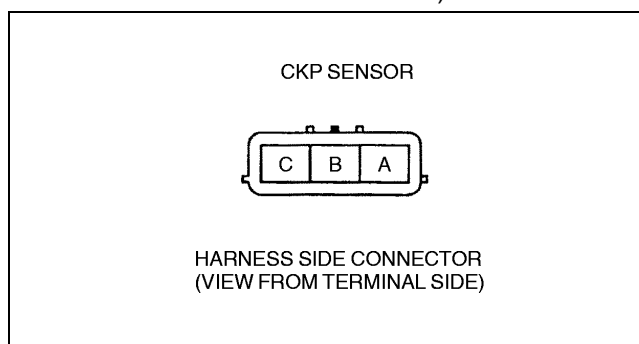

Y3U140WAF

# CONTROL SYSTEM [ZM]

## CRANKSHAFT POSITION (CKP) SENSOR ADJUSTMENT [ZM]

A3U014018230W04

1. Loosen the CKP sensor installation bolt.
2. While moving the CKP sensor, adjust the air gap between the CKP sensor and the plate teeth on the plate using a feeler gauge.
  - If not adjusted within specification, replace the plate behind the crankshaft pulley or CKP sensor. (See 01-40A-34 PLATE REMOVAL/INSTALLATION [ZM].) (See 01-40A-34 CRANKSHAFT POSITION (CKP) SENSOR REMOVAL/INSTALLATION [ZM].)

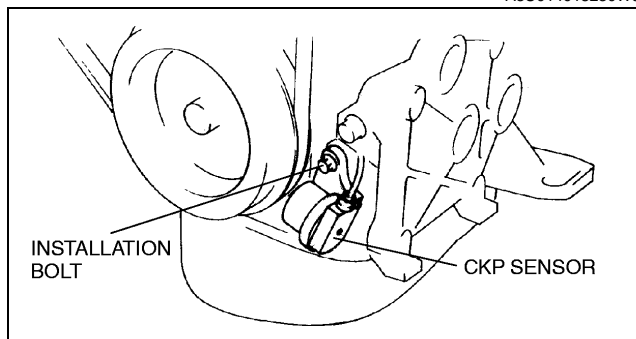

X3U140WAD

### Specification

0.5—1.5 mm {0.020—0.059 in}

3. Tighten the CKP sensor installation bolt.

### Tightening torque

7.9—10.7 N·m  
{80—110 kgf·cm, 69.5—95.4 in·lbf}

## CRANKSHAFT POSITION (CKP) SENSOR REMOVAL/INSTALLATION [ZM]

A3U014018230W05

### Caution

- When foreign material such as an iron chip is on the CKP sensor, it can cause abnormal output from the sensor because of flux turbulence and adversely affect the engine control. Be sure there is no foreign material on the CKP sensor when replacing.

1. Disconnect the CKP sensor connector.
2. Remove the undercover.
3. Remove the CKP sensor installation bolt.
4. Install in the reverse order of removal.

### Tightening torque

7.9—10.7 N·m  
{80—110 kgf·cm, 69.5—95.4 in·lbf}

5. Reconnect the CKP sensor connector.

### Caution

- Do not forcefully pull the wiring harness of the CKP sensor, or harness will be damaged.

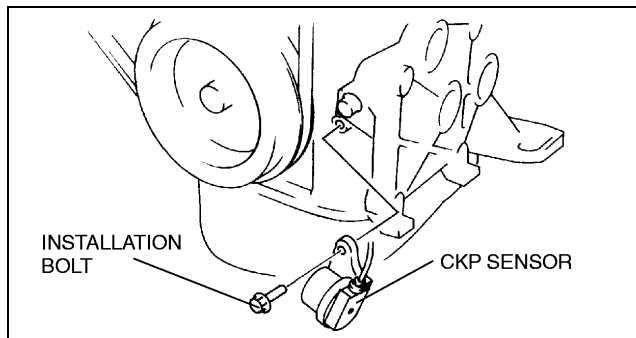

X3U140WAE

6. Adjust the air gap. (See 01-40A-34 CRANKSHAFT POSITION (CKP) SENSOR ADJUSTMENT [ZM].)

## PLATE REMOVAL/INSTALLATION [ZM]

A3U014011408W01

1. Remove the crankshaft pulley. (See 01-10A-9 TIMING BELT REMOVAL/INSTALLATION [ZM].)
2. Remove the plate.

### Note

- Adjust the drive belt when installing the drive belt. (See 01-10A-4 DRIVE BELT ADJUSTMENT [ZM].)

3. Install in the reverse order of removal.

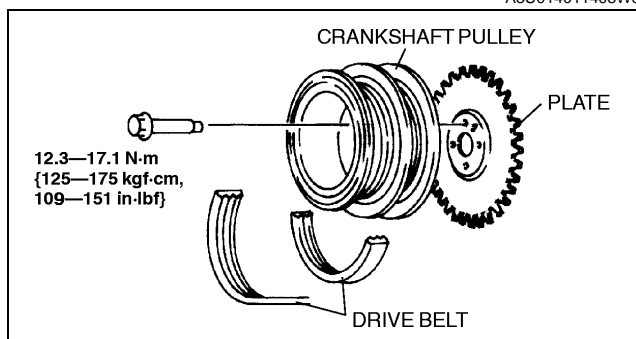

Y3U140WA4

## CAMSHAFT POSITION (CMP) SENSOR REMOVAL/INSTALLATION [ZM]

A3U014018200W03

### Caution

- When foreign material such as an iron chip is on the CMP sensor, it can cause abnormal output from the sensor because of flux turbulence and adversely affect the engine control. Be sure there is no foreign material on the CMP sensor when replacing.

1. Disconnect the negative battery cable.
2. Disconnect the CMP sensor connector.
3. Remove the CMP sensor installation bolt.
4. Remove the CMP sensor.
5. Make sure that the CMP sensor is free of any metallic shavings or particles.
  - If metallic shavings or particles are found on the sensor, clean them off.
6. Install in the reverse order of removal.

### Tightening torque

**7.9—10.7 N·m**  
**{80—110 kgf·cm, 69.5—95.4 in·lbf}**

01-40A

## CAMSHAFT POSITION (CMP) SENSOR INSPECTION [ZM]

A3U014018200W04

### Visual Inspection

1. Remove the CMP sensor. (See 01-40A-35 CAMSHAFT POSITION (CMP) SENSOR REMOVAL/INSTALLATION [ZM].)

### Note

- Make sure that the CMP sensor is free of any metallic shavings or particles.
- If metallic shavings or particles are found on the sensor, clean them off.

2. Install the CMP sensor. (See 01-40A-35 CAMSHAFT POSITION (CMP) SENSOR REMOVAL/INSTALLATION [ZM].)

### Wave profile Inspection

1. Remove the PCM. (See 01-40A-7 PCM REMOVAL/INSTALLATION [ZM].)
2. Connect the **SST** (104 Pin Breakout Box) to the PCM as shown.
3. Tighten the connector attaching screw.

### Tightening torque

**7.9—10.7 N·m**  
**{80—110 kgf·cm, 69.5—95.4 in·lbf}**

4. Connect the oscilloscope testleads to the following PCM connector terminals.
  - (+) lead: PCM terminal 85
  - (-) lead: PCM terminal 103
5. Start the engine.
6. Monitor RPM PID.
7. Inspect wave profile at idle.
  - If wave profile or voltage are out of specifications, carry out the "Circuit Open/Short Inspection".
    - PCM terminal: 85(+) ↔ 103(-)
    - Oscilloscope setting: 2 V/DIV(Y), 20 ms/DIV(X), DC range
    - Vehicle condition: Idle after warm up

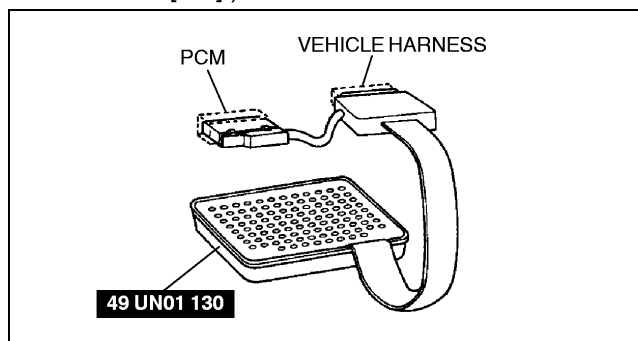

X3U140WBN

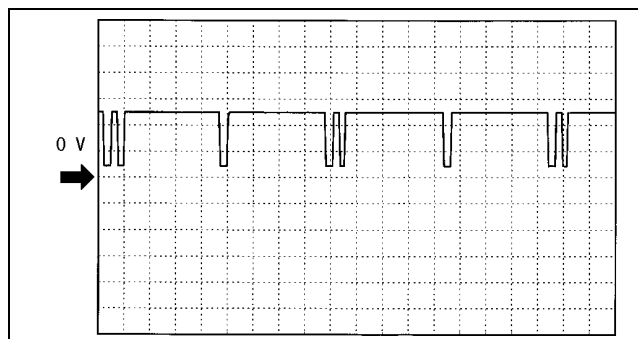

Z3U0140W018

## CONTROL SYSTEM [ZM]

### Circuit Open/Short Inspection

1. Remove the PCM. (See 01-40A-7 PCM REMOVAL/INSTALLATION [ZM].)
2. Connect the **SST** (104 Pin Breakout Box) to the PCM as shown.
3. Tighten the connector attaching screw.

#### Tightening torque

7.9—10.7 N·m

{80—110 kgf·cm, 69.5—95.4 in·lbf}

4. Inspect for an open or short circuit in the following wiring harnesses by probing the applicable sensor and **SST** (104 Pin Breakout Box) terminals with ohmmeter leads.

- If there is an open or short circuit, repair or replace wiring harnesses.
- If there is no open or short circuit, replace the CMP sensor.

#### Open circuit

- CMP signal circuit (CMP sensor connector terminal B and PCM connector terminal 85)
- Power circuit (CMP sensor connector terminal A and main relay terminal D through common connector)
- GND circuit (CMP sensor connector terminal C and PCM connector terminal 103)

#### Short circuit

- CMP signal circuit (CMP sensor connector terminal B and PCM connector terminal 85 to GND)
- Power circuit (CMP sensor connector terminal A and main relay terminal D through common connector to GND)

5. Reconnect the CMP sensor connector.
6. Inspect the camshaft pulley (exhaust side) for damage and cracks.

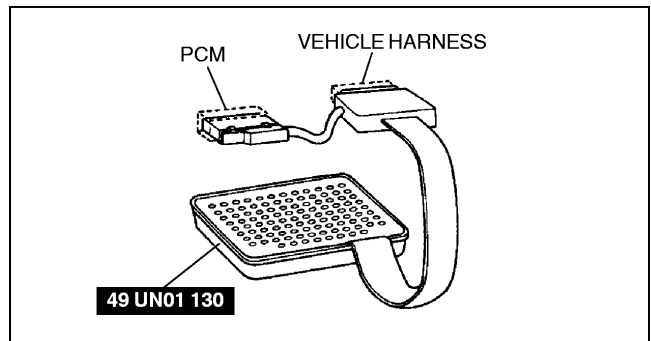

X3U140WBN

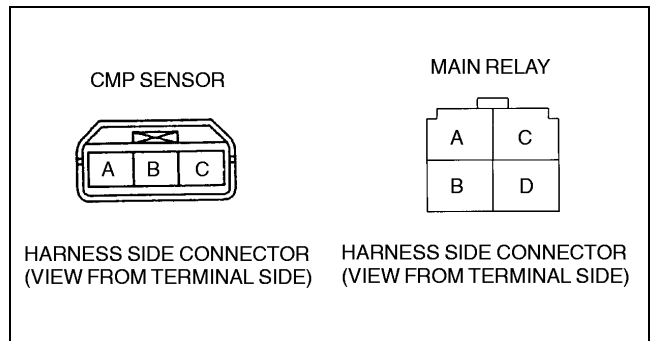

X3U140WAT

## HEATED OXYGEN SENSOR (HO2S) INSPECTION [ZM]

### HO2S (Front and Rear) Voltage Inspection

A3U014018861W02

#### Note

- Perform the following test only when directed.

1. Warm up the engine and run it at idle.
2. Disconnect the HO2S (Front or Rear) connector.
3. Connect the voltmeter test leads to the following HO2S terminals:
  - (+) lead—HO2S terminal A
  - (-) lead—HO2S terminal B
4. Run the engine at **3,000 rpm** until the voltmeter indicates **approx. 0—1.0 V**.
5. Verify that the voltmeter needle moves when the engine speed increases and decreases suddenly several times.
  - If not as specified, replace the HO2S.
  - If the HO2S is okay, but PID value or PCM terminal 60 (Front), 35 (Rear) voltage is out of specification, carry out the "Circuit Open/Short Inspection".

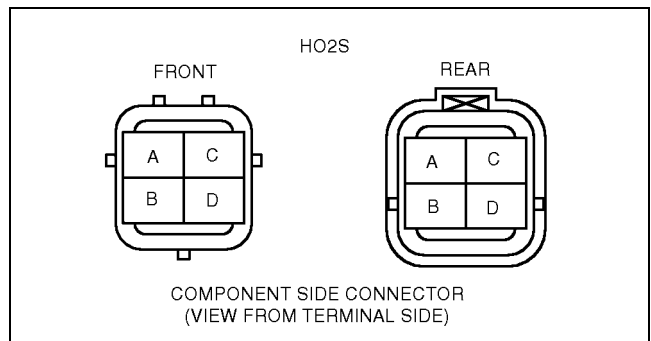

Z3U0140W023

#### Specification

Engine speed	Voltage (V)
Increase	0.5—1.0
Decrease	0—0.5

## Circuit Open/Short Inspection

1. Remove the PCM. (See 01-40A-7 PCM REMOVAL/INSTALLATION [ZM].)
2. Connect the **SST** (104 Pin Breakout Box) to the PCM as shown.
3. Tighten the connector attaching screw.

### Tightening torque

**7.9—10.7 N·m**

**{80—110 kgf·cm, 69.5—95.4 in·lbf}**

4. Inspect for an open or short circuit in the following wiring harnesses by probing the applicable sensor and **SST** (104 Pin Breakout Box) terminals with ohmmeter leads.
  - If there is an open or short circuit, repair or replace wiring harnesses.
  - If there is no open or short circuit, replace the HO2S.

### Open circuit

- HO2S signal circuit (HO2S connector terminal A and PCM connector terminal 60 (Front), 35 (Rear))
- GND circuit (HO2S connector terminal B and PCM connector terminal 91)

### Short circuit

- HO2S signal circuit (HO2S terminal A and PCM connector terminal 60 (Front), 35 (Rear) to GND)

5. Reconnect the HO2S connector.

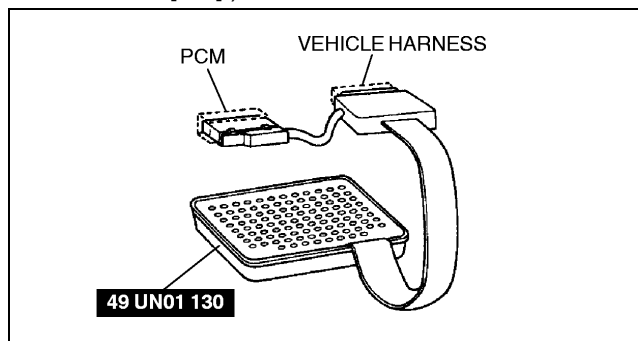

X3U140WBN

01-40A

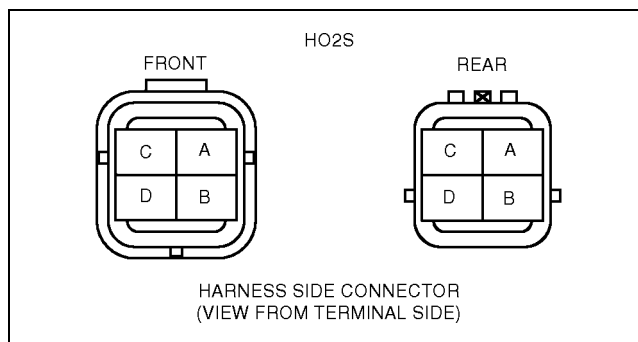

Z3U0140W024

## HO2S Heater (Front and Rear) Resistance Inspection

1. Disconnect the HO2S (Front or Rear) connector.
2. Measure the resistance between HO2S terminals C and D using an ohmmeter.
  - If not as specified, replace the HO2S.
  - If the HO2S heater is okay, but PID value or PCM terminal 94 (Front), 93 (Rear) voltage are out of specification, carry out the "Circuit Open/Short Inspection".

### Specification

**Front: Approx. 5.6 ohms**

**Rear: Approx. 15.7 ohms**

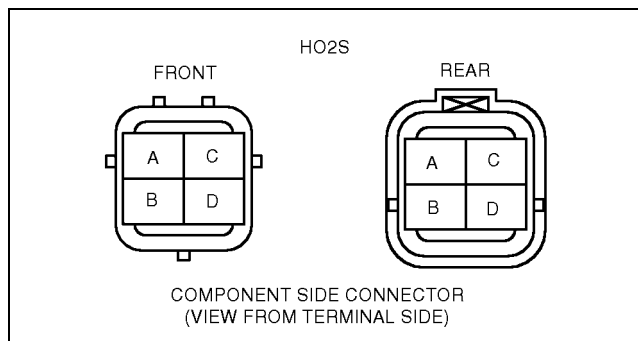

Z3U0140W023



## CONTROL SYSTEM [ZM]

### Circuit Open/Short Inspection

1. Remove the PCM. (See 01–40A–7 PCM REMOVAL/INSTALLATION [ZM].)
2. Connect the **SST** (104 Pin Breakout Box) to the PCM as shown.
3. Tighten the connector attaching screw.

#### Tightening torque

7.9—10.7 N·m

{80—110 kgf·cm, 69.5—95.4 in·lbf}

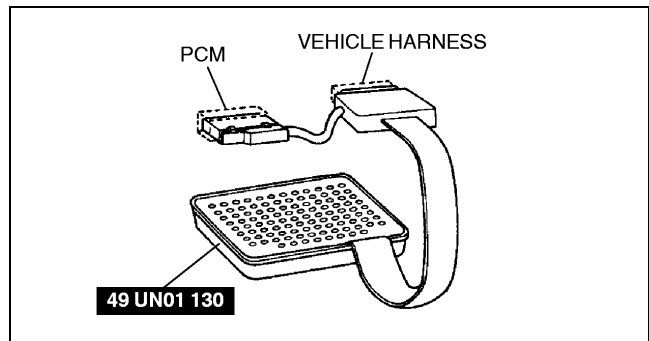

X3U140WBN

4. Inspect for an open or short circuit in the following wiring harnesses by probing the applicable sensor and **SST** (104 Pin Breakout Box) terminals with ohmmeter leads.

- If there is an open or short circuit, repair or replace wiring harnesses.
- If there is no open or short circuit, replace the HO2S.

#### Open circuit

- Control circuit (HO2S connector terminal C and ignition switch (IG1) circuit through common connector)
- GND circuit (HO2S connector terminal D and PCM connector terminal 94 (Front), 93 (Rear))

#### Short circuit

- Control circuit (HO2S connector terminal C and ignition switch (IG1) circuit through common connector to GND)
- GND circuit (HO2S connector terminal D and PCM connector terminal 94 (Front), 93 (Rear) to GND)

5. Reconnect the HO2S connector.

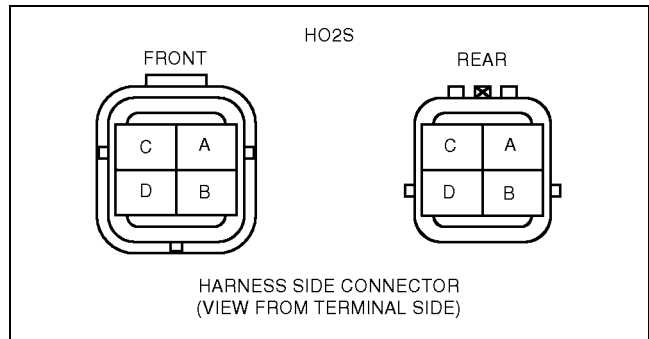

Z3U0140W024

### EGR BOOST SENSOR INSPECTION [ZM]

A3U014018211W02

#### Note

- Perform the following test only when directed.
- The following vacuum values are indicated by relative pressure from barometric pressure.

1. Remove the PCM. (See 01–40A–7 PCM REMOVAL/INSTALLATION [ZM].)
2. Connect the **SST** (104 Pin Breakout Box) to the PCM as shown.
3. Tighten the connector bolt.

#### Tightening torque

7.9—10.7 N·m

{80—110 kgf·cm, 69.5—95.4 in·lbf}

#### Caution

- Do not apply vacuum outside of the specified limits, or EGR boost sensor will be damaged.

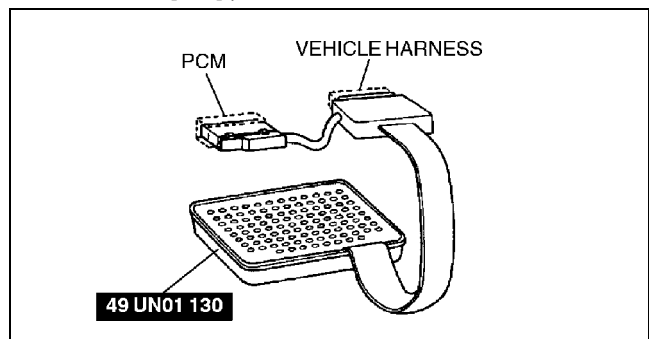

X3U140WAX

4. Turn the ignition switch to ON.

- Disconnect the vacuum hose between the EGR boost sensor and intake manifold.

**Note**

- The output voltage varies with the measuring condition.

- Verify that the PCM terminal 34 voltage is within specification.

**Measuring condition:**

**Input voltage:** 4.5—5.5 V

**Ambient temperature:** 10—50 °C {50—122 °F}

**Sea level:** -20—3,000 m {-656—9,840 ft}

**Specification**

**BARO V variation:** 2.3—4.7 V

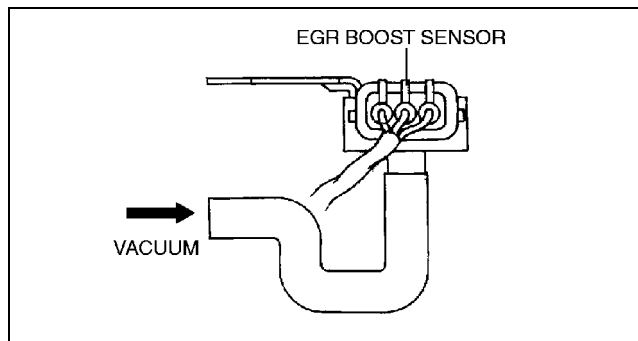

X3U140WAY

01-40A

- Apply vacuum of **-26.6 kPa {-200 mmHg, -7.85 inHg}** to EGR boost sensor and verify that PCM 34 terminal voltage from Step 6 is within specification.
  - If not as specified, carry out the "Circuit Open/Short Inspection".

**Specification**

**BARO V variation:** 0.8—1.3 V

**Circuit Open/Short Inspection**

- Remove the PCM. (See 01-40A-7 PCM REMOVAL/INSTALLATION [ZM].)
- Connect the **SST** (104 Pin Breakout Box) to the PCM as shown.
- Tighten the connector attaching screw.

**Tightening torque**

**7.9—10.7 N·m**

**{80—110 kgf·cm, 69.5—95.4 in·lbf}**

- Inspect for an open or short circuit in the following wiring harnesses by probing the applicable sensor and **SST** (104 Pin Breakout Box) terminals with ohmmeter leads.

- If there is an open or short circuit, repair or replace wiring harnesses.
- If there is no open or short circuit, replace the EGR boost sensor.

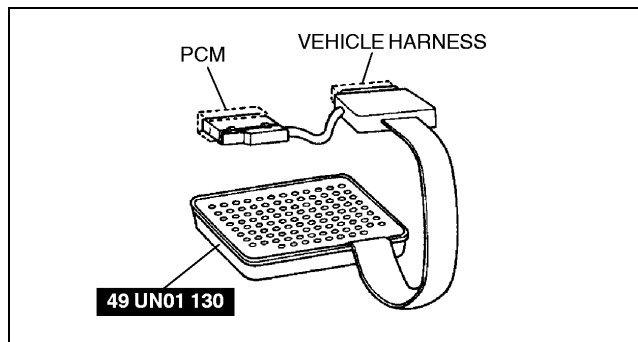

X3U140WBN

**Open circuit**

- EGR boost (Barometric pressure) signal circuit (EGR boost sensor connector terminal A and PCM connector terminal 34)
- Constant voltage circuit (EGR boost sensor connector terminal C and PCM connector terminal 90)
- GND circuit (EGR boost sensor connector terminal B and PCM connector terminal 91)

**Short circuit**

- EGR boost (Barometric pressure) signal circuit (EGR boost sensor connector terminal A and PCM connector terminal 34)
- Constant voltage circuit (EGR boost sensor connector terminal C and PCM connector terminal 90)

- Reconnect the EGR boost sensor connector.

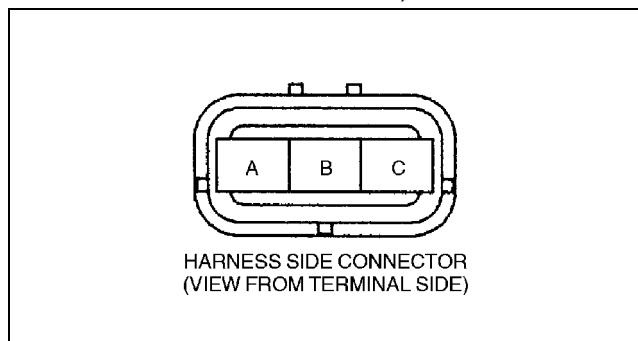

HARNESS SIDE CONNECTOR  
(VIEW FROM TERMINAL SIDE)

Y3U140WA7

# CONTROL SYSTEM [ZM]

## FUEL TANK PRESSURE SENSOR INSPECTION [ZM]

A3U014018212W02

### Note

- Perform the following test only when directed.
- The following vacuum values are indicated by relative pressure from barometric pressure.

1. Remove the PCM. (See 01-40A-7 PCM REMOVAL/INSTALLATION [ZM].)
2. Connect the **SST** (104 Pin Breakout Box) to the PCM as shown.
3. Tighten the connector bolt.

### Tightening torque

**7.9—10.7 N·m**  
**{80—110 kgf·cm, 69.5—95.4 in·lbf}**

### Caution

- **Do not apply vacuum outside of the specified limits, or the fuel tank pressure sensor will be damaged.**

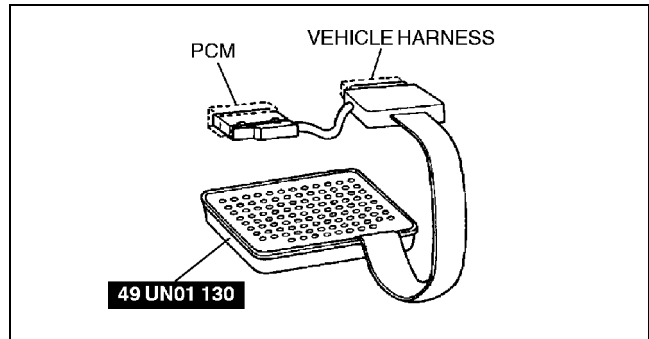

X3U140WB3

4. Turn the ignition switch to ON.
5. Apply pressure then vacuum to the fuel tank pressure sensor according to the following procedure.

### Note

- The output voltage varies with the measuring condition.

6. Decrease the applied pressure from **+6.66 kPa {+50 mmHg, +1.97 inHg}** to **-6.66 kPa {-50 mmHg, -1.97 inHg}** and verify that the PCM terminal 62 voltage decreases accordingly as specified.

- If not as specified, replace the fuel tank pressure sensor.
- If fuel tank pressure sensor is okay, but PCM terminal 62 voltage is out of specification, carry out the "Circuit Open/Short Inspection".

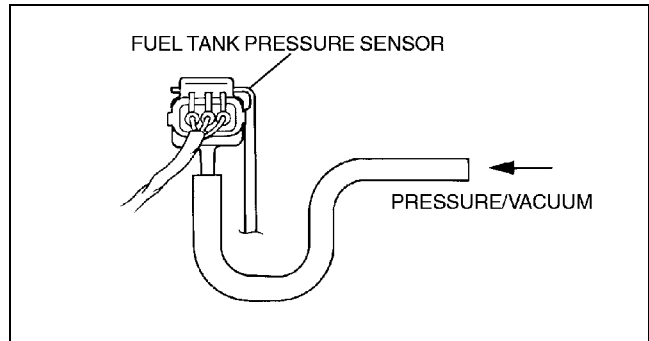

X3U140WB4

### Specification

Applied vacuum	Output voltage (V)*
-6.66 kPa {-50 mmHg, -1.97 inHg}	0.45—0.55
0 kPa {0 mmHg, 0 inHg}	2.25—2.75
+6.66 kPa {+50 mmHg, +1.97 inHg}	4.05—4.95

\* : Measuring condition is as follows.

**Input voltage: 5.0 V**

**Barometric pressure: 101.3 kPa {760 mmHg, 29.9 inHg} (Absolute pressure)**

**Barometric temperature: 30—100 °C {0—182 °F}**

# CONTROL SYSTEM [ZM]

## Circuit Open/Short Inspection

1. Remove the PCM. (See 01-40A-7 PCM REMOVAL/INSTALLATION [ZM].)
2. Connect the **SST** (104 Pin Breakout Box) to the PCM as shown.
3. Tighten the connector attaching screw.

### Tightening torque

7.9—10.7 N·m

{80—110 kgf·cm, 69.5—95.4 in·lbf}

4. Inspect for an open or short circuit in the following wiring harnesses by probing the applicable sensor and **SST** (104 Pin Breakout Box) terminals with ohmmeter leads.
  - If there is an open or short circuit, repair or replace wiring harnesses.
  - If there is no open or short circuit, replace the fuel tank pressure sensor.

### Open circuit

- Fuel tank pressure signal circuit (Fuel tank pressure sensor connector terminal B and PCM connector terminal 62)
- Constant voltage circuit (Fuel tank pressure sensor connector terminal C and PCM connector terminal 90)
- GND circuit (Fuel tank pressure sensor connector terminal A and PCM connector terminal 91)

### Short circuit

- Fuel tank pressure signal circuit (Fuel tank pressure sensor connector terminal B and PCM connector terminal 62)
  - Constant voltage circuit (Fuel tank pressure sensor connector terminal C and PCM connector terminal 90)
5. Reconnect the fuel tank pressure sensor connector.

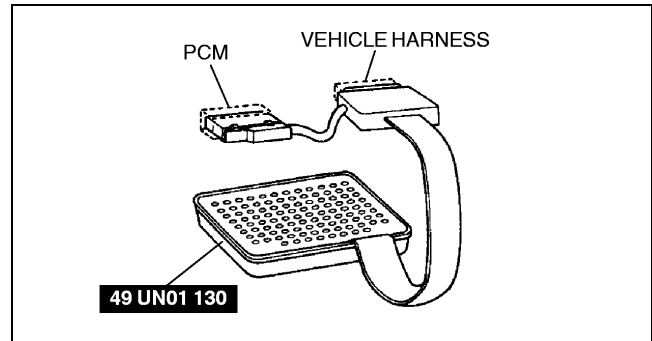

X3U140WBN

01-40A

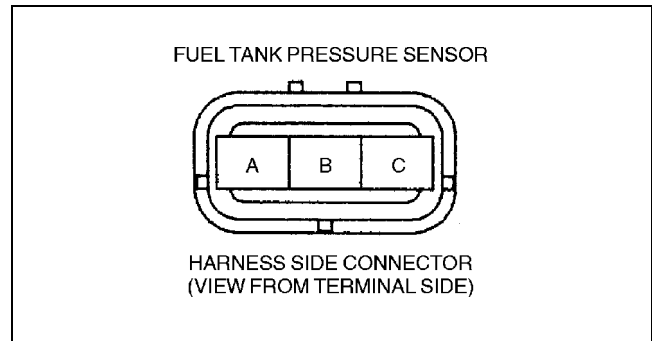

X3U140WB5

A3U014018660W02

## CLUTCH SWITCH INSPECTION [ZM]

### Note

- Perform the following test only when directed.

1. Verify that the clutch switch is installed properly.
2. Disconnect the negative battery cable.
3. Remove the clutch switch. (See 05-10-5 CLUTCH PEDAL REMOVAL/INSTALLATION.)
4. Inspect continuity between the clutch switch terminals A and B using an ohmmeter.
  - If not as specified, replace the clutch switch.
  - If the clutch switch is okay, but PID value or PCM terminal 6 voltage is out of specification, carry out the "Circuit Open/Short Inspection".

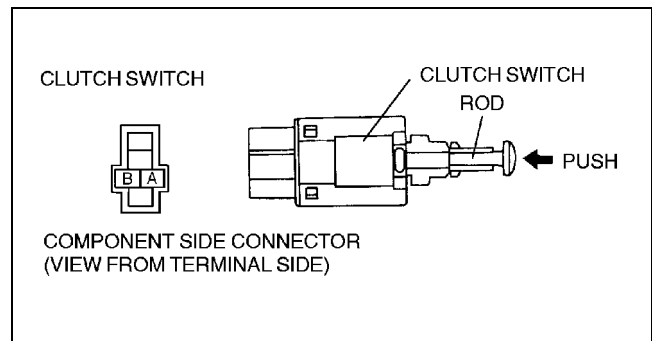

Z3U0140W029

○—○ : Continuity

Condition	Terminal	
	A	B
The rod is pushed		
Except above	○—○	○—○

Z3U0140W030

# CONTROL SYSTEM [ZM]

## Circuit Open/Short Inspection

1. Remove the PCM. (See 01-40A-7 PCM REMOVAL/INSTALLATION [ZM].)
2. Connect the **SST** (104 Pin Breakout Box) to the PCM as shown.
3. Tighten the connector attaching screw.

### Tightening torque

7.9—10.7 N·m

{80—110 kgf·cm, 69.5—95.4 in·lbf}

4. Inspect for an open or short circuit in the following wiring harnesses by probing the applicable sensor and **SST** (104 Pin Breakout Box) terminals with ohmmeter leads.
  - If there is an open or short circuit, repair or replace wiring harnesses.
  - If there is no open or short circuit, replace the clutch switch.

### Open circuit

- Signal circuit (Clutch switch connector terminal B and PCM connector terminal 6 through common connector)
- GND circuit (Clutch switch connector terminal A and GND)

### Short circuit

- Signal circuit (Clutch switch connector terminal B and PCM connector terminal 6 through common connector to GND)

5. Install the clutch switch.

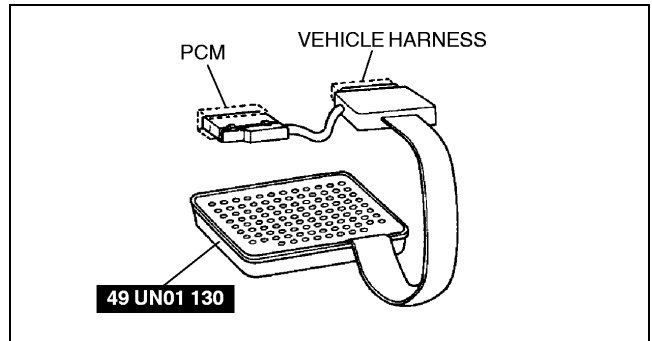

X3U140WBN

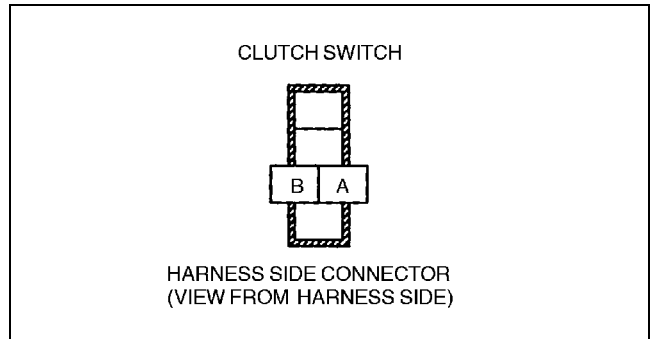

Z3U0140W031

## NEUTRAL SWITCH INSPECTION [ZM]

A3U014017640W02

### Note

- Perform the following test only when directed.

1. Disconnect the negative battery cable.
2. Remove the neutral switch.
3. Inspect for continuity between the neutral switch terminals A and B using an ohmmeter.
  - If not as specified, replace the neutral switch.
  - If the neutral switch is okay, but PID value or PCM terminal 64 voltage is out of specification, carry out the "Circuit Open/Short Inspection".

Condition	Terminal	
	A	B
The rod is pushed	○—○	○—○
Except above		

○—○ : Continuity

X3U140WBD

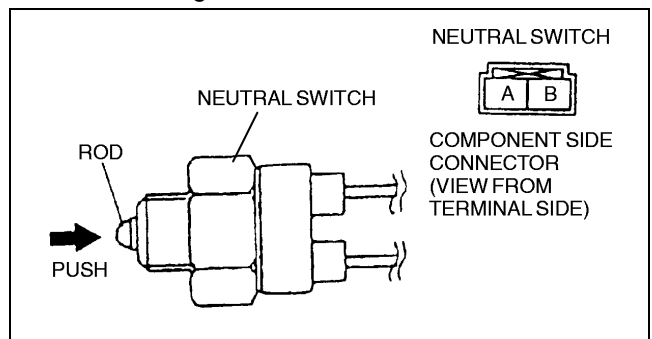

X3U140WBC

# CONTROL SYSTEM [ZM]

## Circuit Open/Short Inspection

1. Remove the PCM. (See 01-40A-7 PCM REMOVAL/INSTALLATION [ZM].)
2. Connect the **SST** (104 Pin Breakout Box) to the PCM as shown.
3. Tighten the connector attaching screw.

### Tightening torque

7.9—10.7 N·m

{80—110 kgf·cm, 69.5—95.4 in·lbf}

4. Inspect for an open or short circuit in the following wiring harnesses by probing the applicable sensor and **SST** (104 Pin Breakout Box) terminals with ohmmeter leads.
  - If there is an open or short circuit, repair or replace wiring harnesses.
  - If there is no open or short circuit, replace the neutral switch.

### Open circuit

- Signal circuit (Neutral switch connector terminal A and PCM connector terminal 64 through common connector)
- GND circuit (Neutral switch connector terminal B and GND through common connector)

### Short circuit

- Signal circuit (Neutral switch connector terminal A and PCM terminal 64 through common connector to GND)

5. Install the neutral switch.

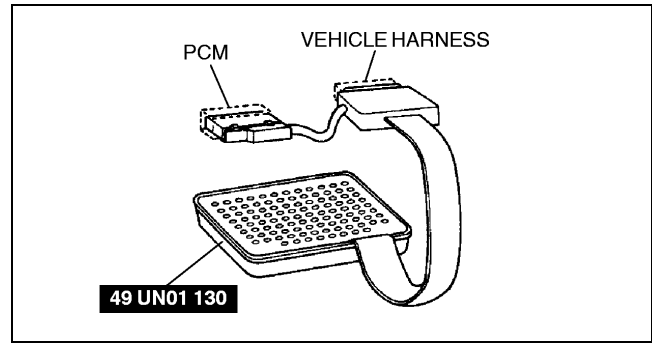

X3U140WBN

01-40A

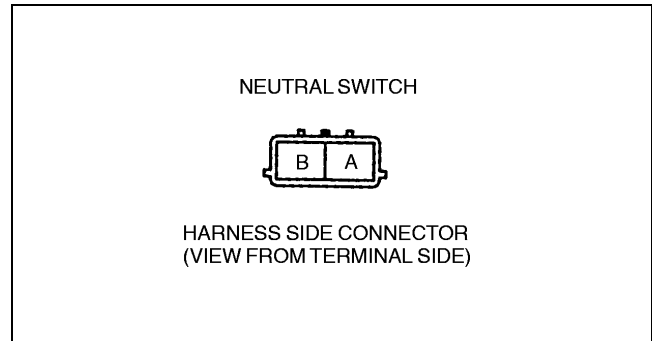

X3U140WBE

## POWER STEERING PRESSURE (PSP) SWITCH INSPECTION [ZM]

A3U014032230W02

### Continuity Inspection

#### Note

- Perform the following test only when directed.

1. Inspect the following if the power steering is inoperative. (See 06-12-3 POWER STEERING FLUID INSPECTION.)
  - Power steering fluid level
  - Power steering fluid leakage
  - Power steering fluid pressure
2. Disconnect the PSP switch connector.
3. Start the engine.
4. Inspect for continuity between the PSP switch terminal and GND using an ohmmeter.
  - If not as specified, replace the PSP switch.
  - If the PSP switch is okay, but PID value or PCM terminal 31 voltage is out of specification, carry out the "Circuit Open/Short Inspection".

○—○ : Continuity

Condition	Terminal	GND
Steering wheel is in straight ahead position		
Steering wheel is fully turned	○—○	○—○

X3U140WBF

## CONTROL SYSTEM [ZM]

### Circuit Open/Short Inspection

1. Remove the PCM. (See 01–40A–7 PCM REMOVAL/INSTALLATION [ZM].)
2. Connect the **SST** (104 Pin Breakout Box) to the PCM as shown.
3. Tighten the connector attaching screw.

#### Tightening torque

7.9—10.7 N·m

{80—110 kgf·cm, 69.5—95.4 in·lbf}

4. Inspect for an open or short circuit in the following wiring harnesses by probing the applicable sensor and **SST** (104 Pin Breakout Box) terminals with ohmmeter leads.

#### Open circuit

- PSP signal circuit (PSP switch connector terminal and PCM connector terminal 31 through common connector)
- GND circuit (PSP switch body and GND)
- If there is an open or short circuit, repair or replace wiring harnesses.
- If there is no open or short circuit, replace the PSP switch.

#### Short circuit

- PSP signal circuit (PSP switch connector terminal and PCM connector terminal 31 through common connector to GND)
5. Reconnect the PSP switch connector.

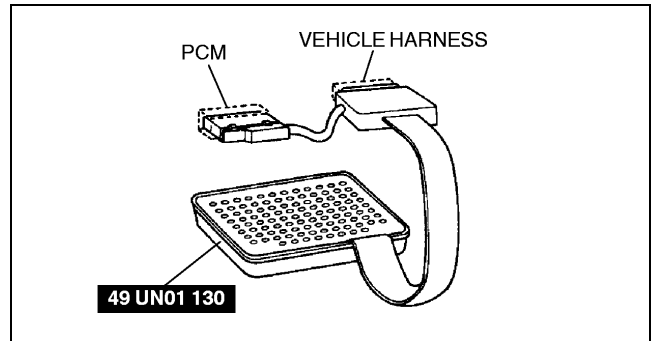

X3U140WBN

**01-40B CONTROL SYSTEM [FS]**

<b>CONTROL SYSTEM COMPONENT</b>		<b>CRANKSHAFT POSITION (CKP) SENSOR</b>	
LOCATION INDEX [FS] . . . . .	01-40B-2	INSPECTION [FS] . . . . .	01-40B-32
<b>CONTROL SYSTEM DIAGRAM [FS] . . .</b>	<b>01-40B-4</b>	Air Gap Inspection . . . . .	01-40B-32
<b>CONTROL SYSTEM WIRING</b>		Resistance Inspection . . . . .	01-40B-33
DIAGRAM [FS] . . . . .	01-40B-5	Circuit Open/Short Inspection . . . . .	01-40B-33
<b>PCM REMOVAL/INSTALLATION [FS] . .</b>	<b>01-40B-7</b>	<b>CRANKSHAFT POSITION (CKP) SENSOR</b>	
<b>PCM INSPECTION [FS] . . . . .</b>	<b>01-40B-7</b>	REMOVAL/INSTALLATION [FS] . . . . .	01-40B-34
PCM Inspection Using the SST		<b>CAMSHAFT POSITION (CMP) SENSOR</b>	
(WDS or equivalent) . . . . .	01-40B-7	REMOVAL/INSTALLATION [FS] . . . . .	01-40B-34
PCM Inspection Using the SST		<b>CAMSHAFT POSITION (CMP) SENSOR</b>	
(104 Pin Breakout Box) . . . . .	01-40B-12	INSPECTION [FS] . . . . .	01-40B-35
Inspection Using An Oscilloscope		Resistance Inspection . . . . .	01-40B-35
(Reference) . . . . .	01-40B-22	Circuit Open/Short Inspection . . . . .	01-40B-35
<b>INSPECTION USING AN OSCILLOSCOPE</b>		<b>KNOCK SENSOR INSPECTION [FS] . . .</b>	<b>01-40B-36</b>
<b>(REFERENCE) [FS] . . . . .</b>	<b>01-40B-26</b>	Resistance Inspection . . . . .	01-40B-36
Purpose . . . . .	01-40B-26	Circuit Open/Short Inspection . . . . .	01-40B-36
When Normal . . . . .	01-40B-26	<b>KNOCK SENSOR</b>	
When Plunger Stuck . . . . .	01-40B-26	REMOVAL/INSTALLATION [FS] . . . . .	01-40B-37
<b>INTAKE AIR TEMPERATURE (IAT)</b>		<b>HEATED OXYGEN SENSOR (HO2S)</b>	
<b>SENSOR INSPECTION [FS] . . . . .</b>	<b>01-40B-27</b>	INSPECTION [FS] . . . . .	01-40B-37
Resistance Inspection . . . . .	01-40B-27	HO2S (Front and Rear) Voltage	
Circuit Open/Short Inspection . . . . .	01-40B-27	Inspection . . . . .	01-40B-37
<b>MASS AIR FLOW (MAF) SENSOR</b>		HO2S Heater (Front and Rear)	
<b>INSPECTION [FS] . . . . .</b>	<b>01-40B-28</b>	Resistance Inspection . . . . .	01-40B-38
Circuit Open/Short Inspection . . . . .	01-40B-28	<b>EGR BOOST SENSOR</b>	
<b>THROTTLE POSITION (TP) SENSOR</b>		<b>INSPECTION [FS] . . . . .</b>	<b>01-40B-39</b>
<b>INSPECTION [FS] . . . . .</b>	<b>01-40B-29</b>	Circuit Open/Short Inspection . . . . .	01-40B-40
Resistance Inspection . . . . .	01-40B-29	<b>FUEL TANK PRESSURE SENSOR</b>	
Circuit Open/Short Inspection . . . . .	01-40B-30	<b>INSPECTION [FS] . . . . .</b>	<b>01-40B-40</b>
<b>ENGINE COOLANT TEMPERATURE (ECT)</b>		Circuit Open/Short Inspection . . . . .	01-40B-41
<b>SENSOR REMOVAL/INSTALLATION</b>		<b>CLUTCH SWITCH INSPECTION [FS] . . .</b>	<b>01-40B-42</b>
<b>[FS] . . . . .</b>	<b>01-40B-30</b>	Circuit Open/Short Inspection . . . . .	01-40B-42
<b>ENGINE COOLANT TEMPERATURE (ECT)</b>		<b>NEUTRAL SWITCH INSPECTION [FS] . .</b>	<b>01-40B-43</b>
<b>SENSOR INSPECTION [FS] . . . . .</b>	<b>01-40B-31</b>	Circuit Open/Short Inspection . . . . .	01-40B-43
ECT Sensor Resistance Inspection . . .	01-40B-31	<b>POWER STEERING PRESSURE (PSP)</b>	
Circuit Open/Short Inspection . . . . .	01-40B-32	<b>SWITCH INSPECTION [FS] . . . . .</b>	<b>01-40B-44</b>
		Continuity Inspection . . . . .	01-40B-44
		Circuit Open/Short Inspection . . . . .	01-40B-44



# CONTROL SYSTEM [FS]

## CONTROL SYSTEM COMPONENT LOCATION INDEX [FS]

A3U014018881W01

### Engine compartment side

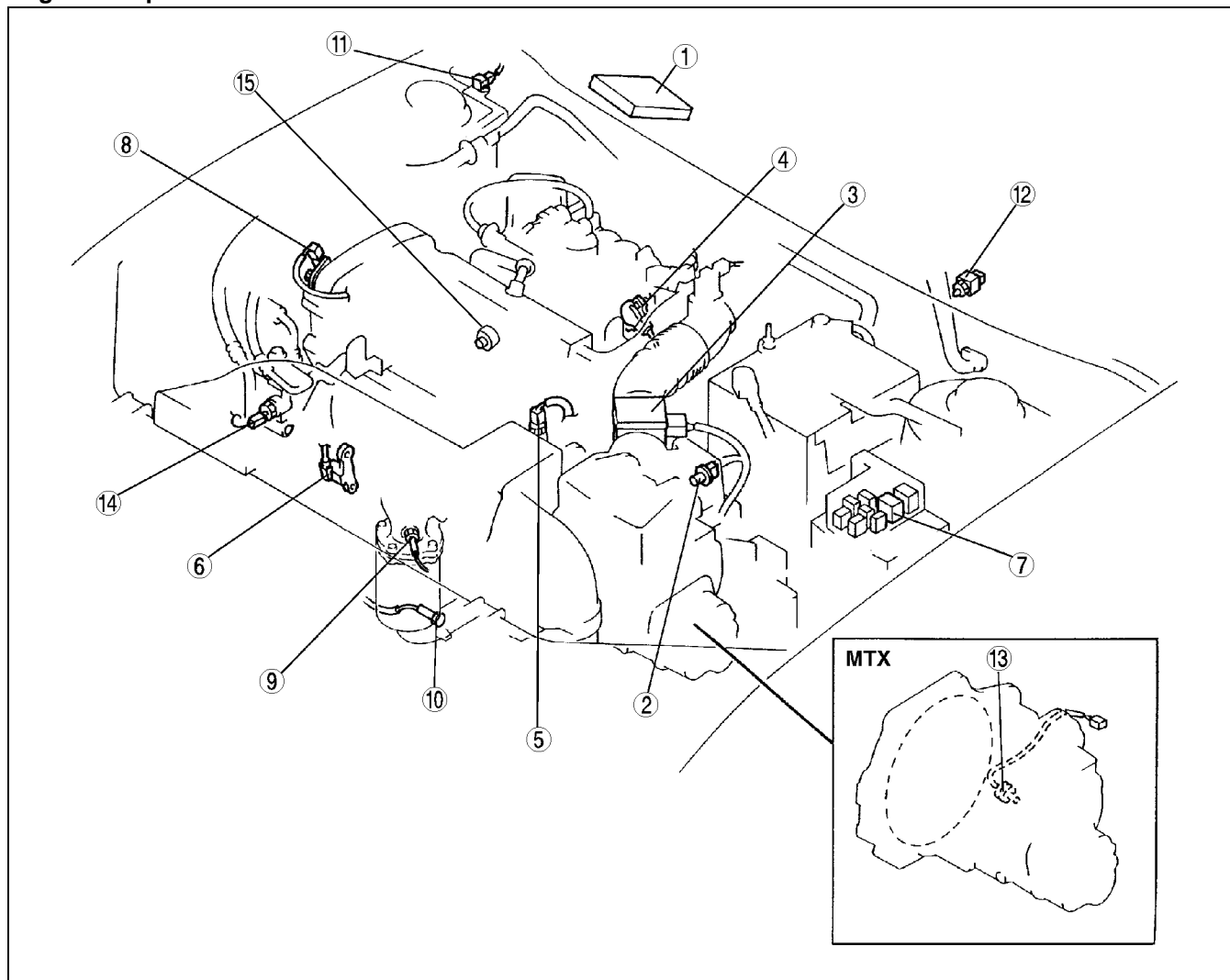

Z3U0140W101

1	PCM (See 01-40B-7 PCM REMOVAL/INSTALLATION [FS].) (See 01-40B-7 PCM INSPECTION [FS])
2	Intake air temperature (IAT) sensor (See 01-40B-27 INTAKE AIR TEMPERATURE (IAT) SENSOR INSPECTION [FS])
3	Mass air flow (MAF) sensor (See 01-40B-28 MASS AIR FLOW (MAF) SENSOR INSPECTION [FS])
4	Throttle position (TP) sensor (See 01-40B-29 THROTTLE POSITION (TP) SENSOR INSPECTION [FS])
5	Engine coolant temperature (ECT) sensor (See 01-40B-30 ENGINE COOLANT TEMPERATURE (ECT) SENSOR REMOVAL/INSTALLATION [FS]) (See 01-40B-31 ENGINE COOLANT TEMPERATURE (ECT) SENSOR INSPECTION [FS])
6	Crankshaft position (CKP) sensor (See 01-40B-32 CRANKSHAFT POSITION (CKP) SENSOR INSPECTION [FS]) (See 01-40B-34 CRANKSHAFT POSITION (CKP) SENSOR REMOVAL/INSTALLATION [FS])

7	Main relay (See 09-21-5 RELAY INSPECTION)
8	Camshaft position (CMP) sensor (See 01-40B-34 CAMSHAFT POSITION (CMP) SENSOR REMOVAL/INSTALLATION [FS]) (See 01-40B-35 CAMSHAFT POSITION (CMP) SENSOR INSPECTION [FS])
9	Heated oxygen sensor (front) (See 01-40B-37 HEATED OXYGEN SENSOR (HO2S) INSPECTION [FS])
10	Heated oxygen sensor (rear) (See 01-40B-37 HEATED OXYGEN SENSOR (HO2S) INSPECTION [FS])
11	EGR boost sensor (See 01-40B-39 EGR BOOST SENSOR INSPECTION [FS])
12	Clutch switch (See 01-40B-42 CLUTCH SWITCH INSPECTION [FS])
13	Neutral switch (See 01-40B-43 NEUTRAL SWITCH INSPECTION [FS])
14	Power steering pressure (PSP) switch (See 01-40B-44 POWER STEERING PRESSURE (PSP) SWITCH INSPECTION [FS])

## CONTROL SYSTEM [FS]

- |    |  |
|----|--|
| 15 | Knock sensor<br>(See 01-40B-36 KNOCK SENSOR INSPECTION [FS]) |
|----|--|

### Fuel tank side

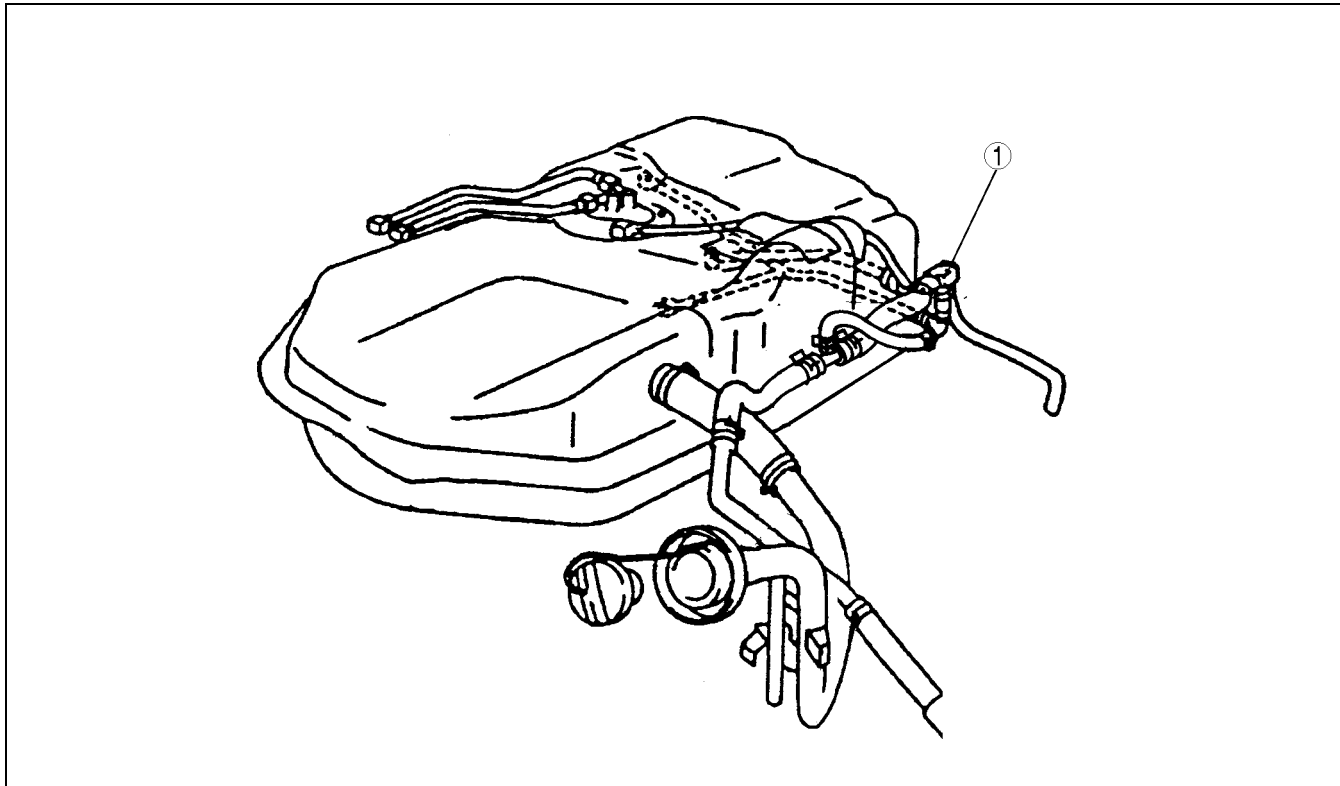

01-40B

- |   |  |
|---|--|
| 1 | Fuel tank pressure sensor<br>(See 01-40B-40 FUEL TANK PRESSURE SENSOR INSPECTION [FS]) |
|---|--|

Z3U0140W002

# CONTROL SYSTEM [FS]

## CONTROL SYSTEM DIAGRAM [FS]

A3U014018881W02

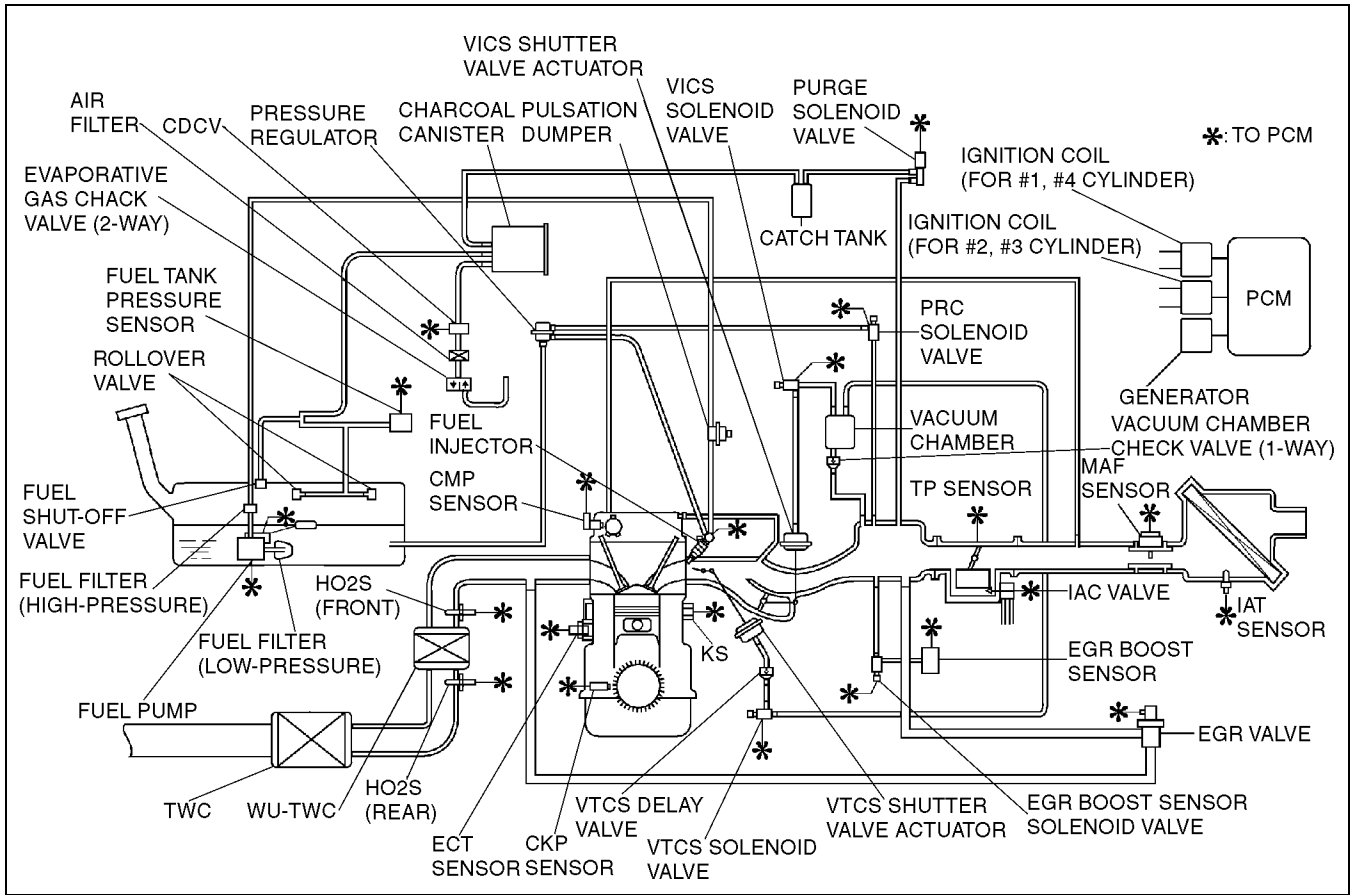

Z3U0140W102

# CONTROL SYSTEM [FS]

## CONTROL SYSTEM WIRING DIAGRAM [FS]

A3U014018881W03

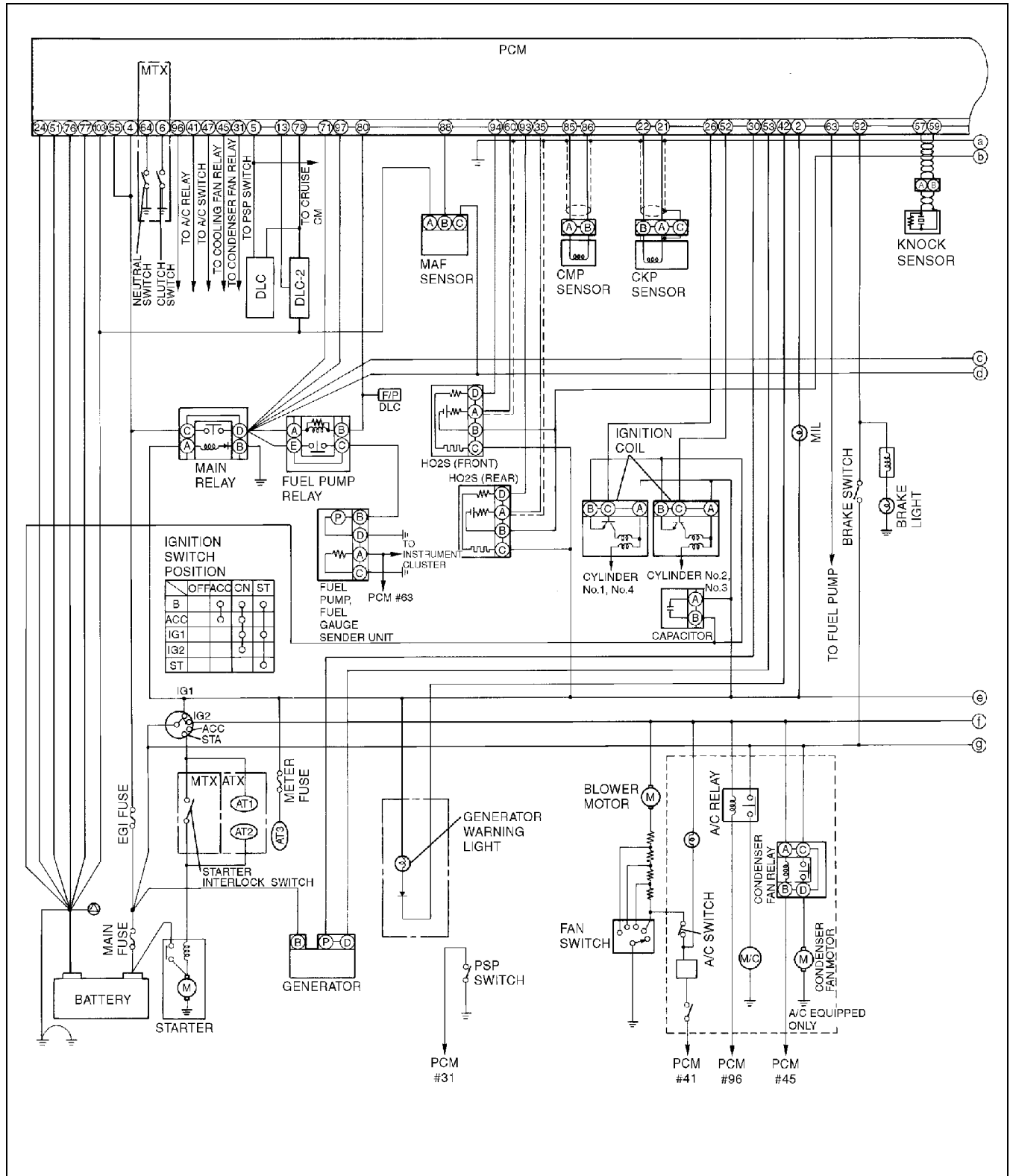

01-40B

A3U0140W001

# CONTROL SYSTEM [FS]

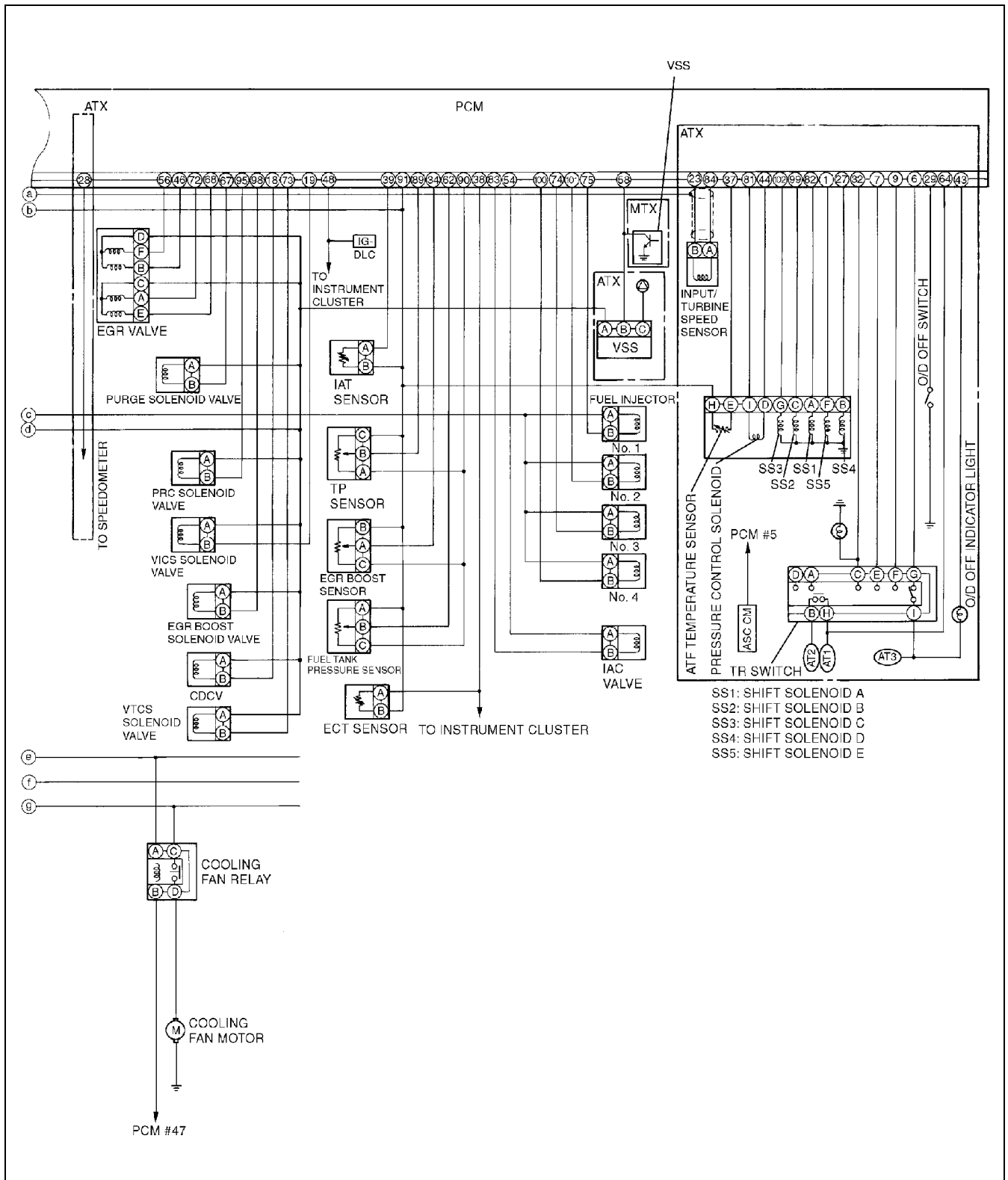

Z3U0140W104

# CONTROL SYSTEM [FS]

## PCM REMOVAL/INSTALLATION [FS]

A3U014018880W01

1. Disconnect the negative battery cable.
2. Remove the front passenger side scuff plate.
3. Remove the front passenger side trim.
4. Partially peel off the floor covering from the front of the passenger's side.

### Warning

- The edge of the PCM plate is sharp. Be careful not to cut yourself when handling the PCM plate.

01-40B

5. Remove in the order indicated in the table.
6. Install in the reverse order of removal.

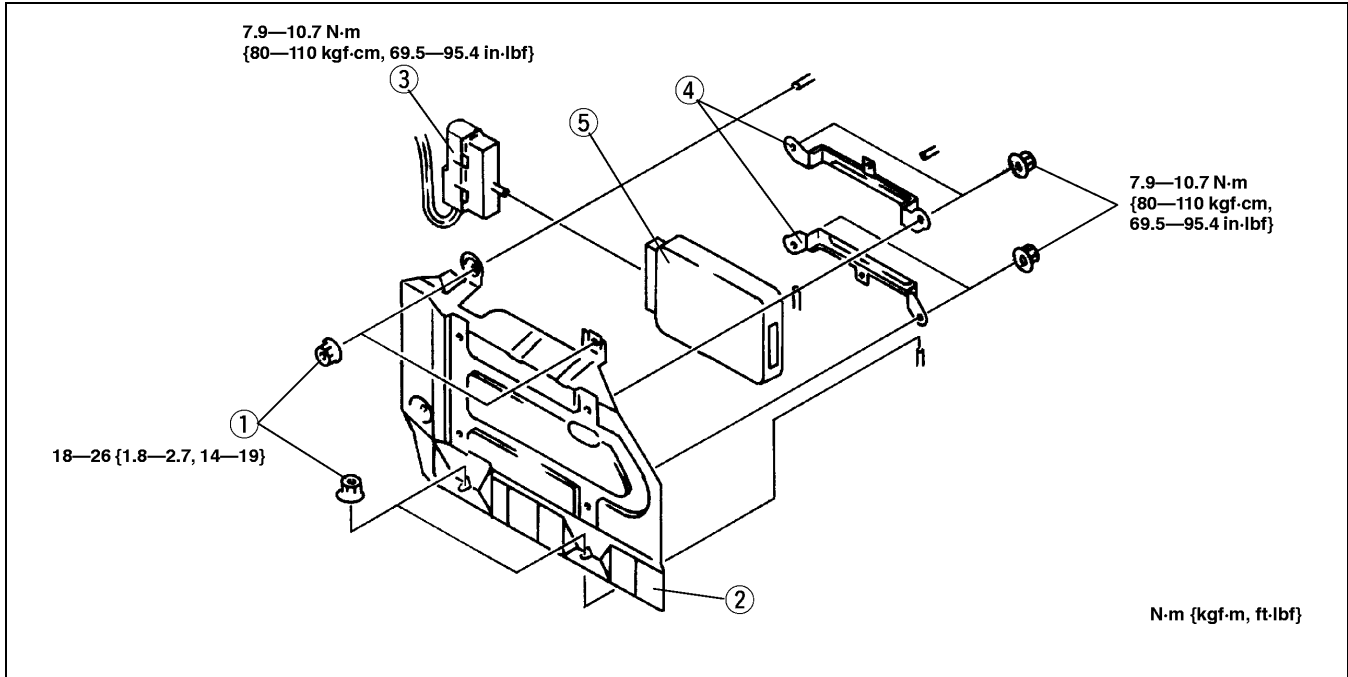

X3U140WD1

1	Nut
2	PCM panel
3	PCM connector

4	Bracket
5	PCM

## PCM INSPECTION [FS]

A3U014018880W02

### Caution

- The PCM terminal voltages vary with change in measuring conditions and vehicle conditions. Always complete the inspection of the input systems, output systems, and PCM to determine the cause of trouble. Otherwise, diagnosis will fail.

### PCM Inspection Using the SST (WDS or equivalent)

#### Note

- PIDs for the following parts are not available on this model. Go to the appropriate part inspection page.
  - CMP sensor (See 01-40B-35 CAMSHAFT POSITION (CMP) SENSOR INSPECTION [FS].)
  - Main relay (See 09-21-5 RELAY INSPECTION.)

1. Connect the WDS or equivalent to the DLC-2. (See 01-02B-7 ON-BOARD DIAGNOSTIC TEST [FS].)
2. Turn the ignition switch on.
3. Measure the value.
  - If the value is not within the specification, follow the instruction in Action column.

## CONTROL SYSTEM [FS]

**PID/DATA MONITOR table (Reference)**

Monitor item (Definition)	Unit/ Condition		Condition/Specification (Reference)	Action	PCM terminal
ACCS (A/C relay)	ON/OFF		A/C operating: ON Ignition switch ON: OFF	Inspect following PIDs: RPM, TP, ECT, ACSW Inspect A/C relay (See 09-21-5 RELAY INSPECTION)	96
ACSW (A/C switch)	ON/OFF		A/C switch and fan switch ON: ON A/C switch OFF: OFF	Inspect A/C switch (See 07-40-11 CLIMATE CONTROL UNIT INSPECTION)	41
ALTF (Generator field coil control duty value)	%		Ignition switch ON: 0% Idle: 0—100% Generator operating → E/L ON: Duty value rise	Inspect following PIDs: IAT, RPM, VPWR, B+2, ALTT V Inspect generator (See 01-17-3 GENERATOR INSPECTION)	53
ALTT V (Generator output voltage)	V		Ignition switch ON: 0 V Idle: 14—16 V	Inspect following PIDs: IAT, RPM, VPWR, B+2, ALTF Inspect generator (See 01-17-3 GENERATOR INSPECTION)	30
ARPMDES (Target engine speed)	rpm		Idle (No load): 650—750 rpm	Perform "On-Board Diagnostic Test" (See 01-02B-7 ON-BOARD DIAGNOSTIC TEST [FS])	—
BARO (Barometric pressure)	kPa	Hg	Below 400 m {0.25 mile} above sea level: 99—103 kPa {29—30 inHg}	Inspect EGR boost sensor (See 01-40B-39 EGR BOOST SENSOR INSPECTION [FS])	34
	V		Below 400 m {0.25 mile} above sea level: 4.1—4.3 V	Inspect EGR boost sensor (See 01-40B-39 EGR BOOST SENSOR INSPECTION [FS])	34
BOO (Brake switch)	ON/OFF		Brake pedal depressed: ON Brake pedal released: OFF	Inspect brake switch (See 04-11-5 BRAKE SWITCH INSPECTION)	92
B+2 (PCM back-up positive voltage)	V		Constant: B+	Inspect battery (See 01-17-1 BATTERY INSPECTION)	4
CDCV (Canister drain cut valve)	ON/OFF		Ignition switch ON: OFF Idle: OFF	Inspect CDCV (See 01-16-10 CANISTER DRAIN CUT VALVE (CDCV) INSPECTION)	18
CHRGLP (Generator warning light)	ON/OFF		Ignition switch ON: ON Idle: OFF	Inspect generator warning light	42
CPP*2 (Clutch switch)	ON/OFF		Clutch pedal depressed: ON Clutch pedal released: OFF	Inspect clutch switch (See 01-40B-42 CLUTCH SWITCH INSPECTION [FS])	6
ECT (Engine coolant temperature)	°C	°F	ECT 20 °C {68 °F}: 20 °C {68 °F} ECT 60 °C {140 °F}: 60 °C {140 °F}	Inspect ECT sensor (See 01-40B-31 ENGINE COOLANT TEMPERATURE (ECT) SENSOR INSPECTION [FS])	38
	V		ECT 20 °C {68 °F}: 2.9—3.1 V After warm up: 0.2—1.0 V	Inspect ECT sensor (See 01-40B-31 ENGINE COOLANT TEMPERATURE (ECT) SENSOR INSPECTION [FS])	38
EGRCHK (EGR boost sensor solenoid valve)	ON/OFF		Ignition switch ON: OFF Idle: OFF	Inspect EGR boost sensor solenoid valve (See 01-16-17 EGR BOOST SENSOR SOLENOID VALVE INSPECTION)	98
EVAPCP (Purge solenoid valve duty value)	%		Ignition switch ON: 0% Idle: 0%	Inspect following PIDs: IAT, RPM, ECT, MAF, TP, BARO, O2S11, VPWR Inspect purge solenoid valve (See 01-16-12 PURGE SOLENOID VALVE INSPECTION)	67
FAN2 (Condenser fan control)	ON/OFF		A/C operated: ON Others: OFF	Inspect following PIDs: RPM, TP, ECT, ACSW, TEST Inspect condenser fan relay (See 09-21-5 RELAY INSPECTION)	45

## CONTROL SYSTEM [FS]

Monitor item (Definition)	Unit/ Condition	Condition/Specification (Reference)	Action	PCM terminal
FAN3 (Cooling fan control)	ON/OFF	Cooling fan operating (ECT above 97 °C {207 °F}) or terminal TEN grounded and throttle valve open or A/C relay on: ON Others: OFF	Inspect following PIDs: RPM, TP, ECT, ACSW, TEST Inspect cooling fan relay (See 09-21-5 RELAY INSPECTION)	47
FP (Fuel pump relay)	ON/OFF	Ignition switch ON: OFF Idle: ON Cranking: ON	Inspect following PID: RPM Inspect fuel pump relay (See 09-21-5 RELAY INSPECTION)	80
FPRC (PRC solenoid valve)	ON/OFF	Ignition switch ON: OFF Idle: OFF After hot start: ON	Inspect PRC solenoid valve (See 01-14-31 PRC SOLENOID VALVE INSPECTION)	95
FTL V (Fuel tank level signal voltage)	V	Idle condition <ul style="list-style-type: none"> <li>Fuel tank full: 1.0—1.5 V</li> <li>Fuel tank empty: 4.4—4.8 V</li> <li>Fuel tank half: 2.8—3.4 V</li> </ul> <b>Note</b> <ul style="list-style-type: none"> <li>The voltages above will be measured when the battery positive voltage is between 12V and 14 V.</li> </ul>	Inspect fuel gauge sender unit (See 09-22-4 Fuel Gauge)	63
FTP (Fuel tank pressure)	kPa Hg	Ignition switch ON: 0—1.0 kPa {0—0.3 inHg} Idle: 0—1.0 kPa {0—0.3 inHg}  <b>Note</b> <ul style="list-style-type: none"> <li>The pressure and output voltage varies according to the fuel temperature.</li> </ul>	Inspect fuel tank pressure sensor (See 01-40B-40 FUEL TANK PRESSURE SENSOR INSPECTION [FS])	62
	V	Ignition switch ON: 2.5—2.8 V Idle: 2.5—2.8 V Fuel tank pressure 0 kPa {0 mmHg, 0 inHg}: 2.5 V Fuel tank pressure 1 kPa {7.5 mmHg, 0.3 inHg}: 2.8 V  <b>Note</b> <ul style="list-style-type: none"> <li>The pressure and output voltage vary according to the fuel temperature.</li> </ul>	Inspect fuel tank pressure sensor (See 01-40B-40 FUEL TANK PRESSURE SENSOR INSPECTION [FS])	62
FTP1SV	kPa	Perform "DTC INSPECTION". (See 01-02B-15 DTC TABLE [FS])		—
FTP2SV	kPa			
FUELPW1 (Fuel injection duration)	ms	Ignition switch ON: 0 msec Idle: 2.5—4.0 msec	Inspect following PIDs: MAF, IAT, RPM, TP, ECT, PNP, CPP, O2S11, PSP, BOO, ACSW, VPWR Inspect CMP sensor (See 01-40B-35 CAMSHAFT POSITION (CMP) SENSOR INSPECTION [FS])	74, 75, 100, 101
GEAR (Gear position)	1/2/3/4	1GR: 1 2GR: 2 3GR: 3 4GR: 4	Inspect following PIDs: SSA/SS1, SSB/SS2, SSC/SS3, SSD/SS4, SSE/SS5	1, 27, 82, 99, 102
HTR11 (HO2S heater (Front))	ON/OFF	Ignition switch ON (engine stopped): OFF Approx. 15 seconds after engine start with ECT 20—30 °C {68—86°F}* : ON Others: ON ⇔ OFF	Inspect following PIDs: ECT V, MAF V. Inspect HO2S heater (See 01-40B-38 HO2S Heater (Front and Rear) Resistance Inspection)	94
HTR12 (HO2S heater (Rear))	ON/OFF	ECT above 70 °C {158 °F}: ON HO2S (Rear) heater is malfunctioning: OFF	Inspect following PIDs: ECT V, MAF V Inspect HO2S heater (See 01-40B-38 HO2S Heater (Front and Rear) Resistance Inspection)	93

01-40B



## CONTROL SYSTEM [FS]

Monitor item (Definition)	Unit/ Condition		Condition/Specification (Reference)	Action	PCM terminal
IAC (IAC valve)	%		Ignition switch ON: 0% Idle: 25—35%	Inspect following PIDs: IAT V, RPM, ECT V, MAF V, TP V, NL SW, CLT SW, PSP SW, A/C SW, TEN Inspect IAC valve (See 01-13B-8 IDLE AIR CONTROL (IAC) VALVE INSPECTION [FS])	54, 83
IAT (Intake air temperature)	°C	°F	IAT 20 °C {68 °F}: 20 °C {68 °F}	Inspect IAT sensor (See 01-40B-27 INTAKE AIR TEMPERATURE (IAT) SENSOR INSPECTION [FS])	39
	V		IAT 20 °C {68 °F}: 2.3—2.4 V IAT 30 °C {86 °F}: 1.7—1.9 V	Inspect IAT sensor (See 01-40B-27 INTAKE AIR TEMPERATURE (IAT) SENSOR INSPECTION [FS])	39
IMRC (VTCS solenoid valve)	ON/OFF		ECT above 65 °C {149 °F} while idling: OFF ECT below 65 °C {149 °F} and engine speed at 1,500 rpm: ON	Inspect VTCS solenoid valve (See 01-13B-15 VARIABLE TUMBLE CONTROL SYSTEM (VTCS) SOLENOID VALVE INSPECTION [FS])	19
IVC (VICS solenoid valve)	ON/OFF		Engine speed above 4,750 rpm: OFF Engine speed below 4,750 rpm: ON	Inspect VICS solenoid valve (See 01-13B-12 VARIABLE INERTIA CHARGING SYSTEM (VICS) SOLENOID VALVE INSPECTION [FS])	—
LOAD (Load)	%		Idle: 13—20% (MTX), 14—22% (ATX) Engine speed at 2,500 rpm: 11—17% (MTX), 13—19% (ATX)	Perform "On-Board Diagnostic Test" (See 01-02B-7 ON-BOARD DIAGNOSTIC TEST [FS])	—
LONGFT1 (Long fuel trim)	%		Idle: -5—5%	Perform "On-Board Diagnostic Test" (See 01-02B-7 ON-BOARD DIAGNOSTIC TEST [FS])	—
LPS*1 (Pressure control solenoid)	A		Change current value according to throttle opening angle	Inspect pressure control solenoid (See 05-17-28 SOLENOID VALVES INSPECTION)	44, 81
MAF (Intake MAF)	gm/s		Idle: 1.6—2.2 g/s (MTX), 1.6—2.4 g/s (ATX) Engine speed at 2,500 rpm: 5.1—6.5 g/s (MTX), 5.6—7.2 g/s (ATX)	Inspect MAF sensor (See 01-40B-28 MASS AIR FLOW (MAF) SENSOR INSPECTION [FS])	88
	V		Ignition switch ON: 0.6—2.0 V Idle: 0.8—2.2 V	Inspect MAF sensor (See 01-40B-28 MASS AIR FLOW (MAF) SENSOR INSPECTION [FS])	88
MIL (Malfunction indicator light)	ON/OFF		Ignition switch ON: ON DTC output: ON No DTC output: OFF	Inspect MIL	2
MODE1 (Readiness Function Code)	ON/OFF		RFC exists: ON No RFC: OFF	—	—
O2S11 (HO2S (Front))	V		Ignition switch ON: 0—1.0 V After warm up: 0—1.0 V Acceleration: 0.5—1.0 V Deceleration: 0—0.5 V	Inspect HO2S (See 01-40B-37 HO2S (Front and Rear) Voltage Inspection)	60
O2S12 (HO2S (Rear))	V		Ignition switch ON: 0—1.0 V Idle (After warm up): 0—1.0 V Idle (Engine cold): 0—0.5 V Accelerate: 0.5—1.0 V Decelerate: 0—0.5 V	Inspect HO2S (See 01-40B-37 HO2S (Front and Rear) Voltage Inspection)	35
PNP*1 (TR switch)	ON/OFF		P or N range: ON Others: OFF	Inspect TR switch (See 05-17-20 TRANSAXLE RANGE (TR) SWITCH INSPECTION)	64
PNP*2 (Neutral switch)	ON/OFF		Shift position at neutral: ON Others: OFF	Inspect neutral switch (See 01-40B-43 NEUTRAL SWITCH INSPECTION [FS])	64
PSP (PSP switch)	ON/OFF		Steering wheel is at straight ahead position: OFF Steering wheel is fully turned: ON	Inspect PSP switch (See 01-40B-44 POWER STEERING PRESSURE (PSP) SWITCH INSPECTION [FS])	31

## CONTROL SYSTEM [FS]

Monitor item (Definition)	Unit/ Condition	Condition/Specification (Reference)	Action	PCM terminal
RPM (Engine speed)	rpm	Idle: 650—750 rpm	Inspect CKP sensor (See 01-40B-32 CRANKSHAFT POSITION (CKP) SENSOR INSPECTION [FS])	21, 22
SEGRP (EGR valve (stepping motor) position)	step	Ignition switch ON: 0 step Idle: 0 step Cranking: 0—60 steps	Inspect following PIDs: ECT V, TP V. Inspect EGR valve (See 01-16-15 EGR VALVE INSPECTION)	46, 56, 68, 72
SHRTFT1 (Short fuel trim)	%	Idle: -10—10%	Perform "On-Board Diagnostic Test" (See 01-02B-7 ON-BOARD DIAGNOSTIC TEST [FS])	—
SPARKADV (Ignition timing)	BTDC	Idle: BTDC 6—18° Idle (Terminal TEN ground): BTDC 9—11°	Inspect following PIDs: MAF, IAT, RPM, TP, ECT, PSP, PNP, CPP, ACSW, TEST Perform Engine tune-up. (See 01-10B-25 ENGINE TUNE-UP [FS])	26, 52
SSA/SS1*1 (Shift solenoid A)	%	Fourth gear: 100% Others: 0%	Inspect shift solenoid A (See 05-17-28 SOLENOID VALVES INSPECTION)	82
SSB/SS2*1 (Shift solenoid B)	%	First gear: 100% Others: 0%	Inspect shift solenoid B (See 05-17-28 SOLENOID VALVES INSPECTION)	99
SSC/SS3*1 (Shift solenoid C)	%	First gear: 100% Second gear: 100% N position: ON Others: 0%	Inspect shift solenoid C (See 05-17-28 SOLENOID VALVES INSPECTION)	102
SSD/SS4*1 (Shift solenoid D)	ON/OFF	P or N position: ON 1 range: ON Others: OFF	Inspect shift solenoid D (See 05-17-28 SOLENOID VALVES INSPECTION)	27
SSE/SS5*1 (Shift solenoid E)	ON/OFF	TCC operating: ON 1 range: ON Others: OFF	Inspect shift solenoid E (See 05-17-28 SOLENOID VALVES INSPECTION)	1
TCIL (O/D OFF indicator light)	ON/OFF	O/D OFF mode: ON Others: OFF	Inspect O/D OFF indicator light	43
TCS (O/D OFF switch)	ON/OFF	O/D OFF switch pressed: ON Others: OFF	Inspect O/D OFF switch (See 05-17-19 O/D OFF SWITCH INSPECTION)	29
TEST (TEN terminal (DLC))	ON/OFF	Open terminal TEN: OFF Short terminal TEN: ON	Inspect DLC TEN terminal and PCM connector terminal 5	5
TFT*1 (Transaxle fluid temperature)	°C    °F	TFT 20 °C {68 °F}: 20 °C {68 °F} TFT 130 °C {266 °F}: 130 °C {266 °F}	Inspect TFT sensor (See 05-17-25 TRANSAXLE FLUID TEMPERATURE (TFT) SENSOR INSPECTION)	37
TFTV*1 (TFT sensor signal voltage)	V	TFT 20 °C {68 °F}: 3.4—3.6 V TFT 130 °C {266 °F}: 0.4—0.5 V	Inspect TFT sensor (See 05-17-25 TRANSAXLE FLUID TEMPERATURE (TFT) SENSOR INSPECTION)	37
TPOD*1 (TP)	%	CTP: 0% WOT: 100%	Inspect TP sensor (See 01-40B-29 THROTTLE POSITION (TP) SENSOR INSPECTION [FS])	89
TP (TP sensor signal voltage)	V	CTP: 0.1—1.1 V WOT: 3.0—4.6 V	Inspect TP sensor (See 01-40B-29 THROTTLE POSITION (TP) SENSOR INSPECTION [FS])	89
TRL*1 (TR switch [1 range])	ON/OFF	1 range: ON Others: OFF	Inspect TR switch (See 05-17-20 TRANSAXLE RANGE (TR) SWITCH INSPECTION)	7
TROD*1 (TR switch [D range])	ON/OFF	D range: ON Others: OFF	Inspect TR switch (See 05-17-20 TRANSAXLE RANGE (TR) SWITCH INSPECTION)	6

01-40B

## CONTROL SYSTEM [FS]

Monitor item (Definition)	Unit/ Condition		Condition/Specification (Reference)	Action	PCM terminal
TRR* <sup>1</sup> (TR switch [R position])	ON/OFF		R position: ON Others: OFF	Inspect TR switch (See 05-17-20 TRANSAXLE RANGE (TR) SWITCH INSPECTION)	32
TRD* <sup>1</sup> (TR switch [2range])	ON/OFF		2 range: ON Others: OFF	Inspect TR switch (See 05-17-20 TRANSAXLE RANGE (TR) SWITCH INSPECTION)	9
TSS* <sup>1</sup> (Input/turbine speed signal)	rpm		Ignition switch ON: 0 rpm Idle: 650—750 rpm	Inspect input/turbine speed sensor (See 05-17-26 INPUT/TURBINE SPEED SENSOR INSPECTION)	23, 84
VPWR (Battery positive voltage)	V		Ignition switch ON: B+	Inspect main relay (See 09-21-5 RELAY INSPECTION) Inspect battery (See 01-17-1 BATTERY INSPECTION)	71, 97
VSS (Vehicle speed)	km/h	mph	Vehicle speed 20 km/h {12.5 mph}; 20 km/h {12.5 mph} Vehicle speed 40 km/h {25 mph}; 40km/h {25 mph}	Inspect VSS MTX: (See 09-22-4 Speedometer) ATX: (See 05-17-27 VEHICLE SPEEDOMETER SENSOR (VSS) INSPECTION [ATX])	58

\*1 : ATX only

\*2 : MTX only

### PCM Inspection Using the SST (104 Pin Breakout Box)

1. Disconnect the negative battery cable.
2. Disconnect the PCM connector.
3. Connect the **SST** (104 Pin Breakout Box) to the PCM as shown.
4. Tighten the connector bolt.

#### Tightening torque

**7.9—10.7 N·m**

**{80—110 kgf·m, 69.5—95.4 in·lbf}**

5. Connect the negative battery cable.
6. Measure the voltage at each terminal.
  - If any incorrect voltage is detected, inspect the related system(s), wiring harnesses and connector(s) referring to the action column in the terminal voltage table.

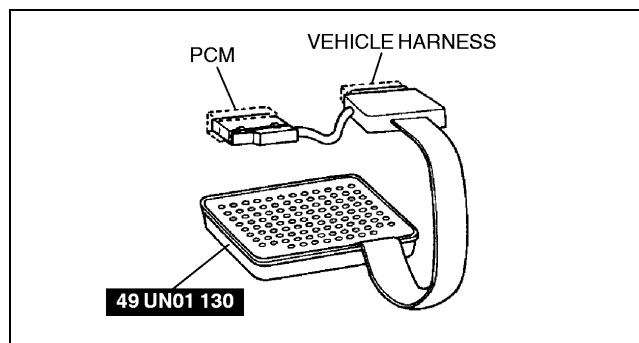

X3U140WA2

# CONTROL SYSTEM [FS]

**Terminal voltage table (Reference)**

Terminal	Signal	Connected to	Test condition		Voltage (V)	Action
1*1	Shift solenoid E control	Shift solenoid E	Idle (P position)		Below 1.0	<ul style="list-style-type: none"> <li>Inspect shift solenoid E (See 05-17-28 SOLENOID VALVES INSPECTION)</li> <li>Inspect related harness</li> </ul>
			1 range (1GR)		B+	
2	MIL control	MIL (in instrument cluster)	Ignition switch ON		Below 1.0	<ul style="list-style-type: none"> <li>Inspect MIL</li> <li>Inspect related harness</li> </ul>
			Idle		B+	
3	—	—	—		—	—
4	B+ monitor	Battery	Under any condition		B+	<ul style="list-style-type: none"> <li>Inspect battery (See 01-17-1 BATTERY INSPECTION)</li> <li>Inspect EGI fuse</li> <li>Inspect related harness</li> </ul>
5	Diagnostic test mode	DLC terminal TEN	Ignition switch ON	Open terminal TEN	B+	<ul style="list-style-type: none"> <li>Inspect related harness</li> </ul>
				Short to ground terminal TEN	Below 1.0	
6	Clutch operation (MTX)	Clutch switch	Clutch pedal depressed		Below 1.0	<ul style="list-style-type: none"> <li>Inspect clutch switch (See 01-40B-42 CLUTCH SWITCH INSPECTION [FS])</li> <li>Inspect related harness</li> </ul>
			Clutch pedal released		B+	
	D range (ATX)	TR switch (terminal G)	Ignition switch ON	Selector lever is at D range	B+	<ul style="list-style-type: none"> <li>Inspect TR switch (See 05-17-20 TRANSAXLE RANGE (TR) SWITCH INSPECTION)</li> <li>Inspect related harness</li> </ul>
		Selector lever is at other than D range		Below 1.0		
7*1	1 range	TR switch (terminal E)	Ignition switch ON	Selector lever is at 1 range	B+	<ul style="list-style-type: none"> <li>Inspect TR switch (See 05-17-20 TRANSAXLE RANGE (TR) SWITCH INSPECTION)</li> <li>Inspect related harness</li> </ul>
				Selector lever is at other than 1 range	Below 1.0	
8	—	—	—		—	—
9*1	2 range	TR switch (terminal F)	Ignition switch ON	Selector lever is at 2 range	B+	<ul style="list-style-type: none"> <li>Inspect TR switch (See 05-17-20 TRANSAXLE RANGE (TR) SWITCH INSPECTION)</li> <li>Inspect related harness</li> </ul>
				Selector lever is at other than 2 range	Below 1.0	
10	—	—	—		—	—
11	—	—	—		—	—
12	—	—	—		—	—
13	EPROM flashing	DLC-2 terminal FEPS	Because this terminal is for serial communication, good/no good judgment by terminal voltage is not possible.			<ul style="list-style-type: none"> <li>Inspect related harness</li> </ul>
14	—	—	—		—	—
15	—	—	—		—	—
16	—	—	—		—	—
17	—	—	—		—	—

01-40B

## CONTROL SYSTEM [FS]

Terminal	Signal	Connected to	Test condition		Voltage (V)	Action
18	CDCV control	CDCV	Ignition switch ON		B+	<ul style="list-style-type: none"> <li>Inspect CDCV (See 01-16-10 CANISTER DRAIN CUT VALVE (CDCV) INSPECTION)</li> <li>Inspect related harness</li> </ul>
			Diagnosis executed (while on-board device control is carried out)		Below 1.0	
19	VICS control	VICS solenoid valve	Engine speed: above 4,750 rpm		B+	<ul style="list-style-type: none"> <li>Inspect VICS solenoid valve (See 01-13B-12 VARIABLE INERTIA CHARGING SYSTEM (VICS) SOLENOID VALVE INSPECTION [FS])</li> <li>Inspect related harness</li> </ul>
			Engine speed: below 4,750 rpm		Below 1.0	
20	—	—	—		—	—
21	NE (+)	CKP sensor	<ul style="list-style-type: none"> <li>Inspect using the wave profile. (See 01-40B-22 Inspection Using An Oscilloscope (Reference))</li> </ul>			<ul style="list-style-type: none"> <li>Inspect CKP sensor (See 01-40B-32 CRANKSHAFT POSITION (CKP) SENSOR INSPECTION [FS])</li> <li>Inspect related harness</li> </ul>
22	NE (-)	CKP sensor	<ul style="list-style-type: none"> <li>Inspect using the wave profile. (See 01-40B-22 Inspection Using An Oscilloscope (Reference))</li> </ul>			<ul style="list-style-type: none"> <li>Inspect CKP sensor (See 01-40B-32 CRANKSHAFT POSITION (CKP) SENSOR INSPECTION [FS])</li> <li>Inspect related harness</li> </ul>
23*1	Input/turbine speed (-)	Input/turbine speed sensor	<ul style="list-style-type: none"> <li>Inspect using the wave profile. (See 01-40B-22 Inspection Using An Oscilloscope (Reference))</li> </ul>			<ul style="list-style-type: none"> <li>Inspect input/turbine speed sensor (See 05-17-26 INPUT/TURBINE SPEED SENSOR INSPECTION)</li> <li>Inspect related harness</li> </ul>
24	GND	GND	Under any condition		Below 1.0	<ul style="list-style-type: none"> <li>Inspect related harness</li> </ul>
25	—	—	—		—	—
26	IGT1	Ignition coil (No. 1, 4 cylinders)	<ul style="list-style-type: none"> <li>Inspect using the wave profile. (See 01-40B-22 Inspection Using An Oscilloscope (Reference))</li> </ul>			<ul style="list-style-type: none"> <li>Inspect ignition coil (See 01-18-2 IGNITION COIL INSPECTION)</li> <li>Inspect related harness</li> </ul>
27*1	Shift solenoid D control	Shift solenoid D	Idle	Selector lever is at P, N position and 1 range	B+	<ul style="list-style-type: none"> <li>Inspect shift solenoid D (See 05-17-28 SOLENOID VALVES INSPECTION)</li> <li>Inspect related harness</li> </ul>
				Others	Below 1.0	
28*1	Vehicle speed output	Speedometer (in instrument cluster)	<ul style="list-style-type: none"> <li>Inspect using the wave profile. (See 01-40B-22 Inspection Using An Oscilloscope (Reference))</li> </ul>			<ul style="list-style-type: none"> <li>Inspect speedometer (See 09-22-4 Speedometer)</li> <li>Inspect related harness</li> </ul>

## CONTROL SYSTEM [FS]

Terminal	Signal	Connected to	Test condition		Voltage (V)	Action
29*1	O/D OFF signal	O/D OFF switch	Ignition switch ON	O/D OFF switch pushed	Below 1.0	<ul style="list-style-type: none"> <li>Inspect O/D OFF switch (See 05-17-19 O/D OFF SWITCH INSPECTION)</li> <li>Inspect related harness</li> </ul>
				O/D OFF switch released	B+	
30	Generator output voltage	Generator (terminal P)	<ul style="list-style-type: none"> <li>Inspect using the wave profile. (See 01-40B-22 Inspection Using An Oscilloscope (Reference))</li> </ul>			<ul style="list-style-type: none"> <li>Inspect generator (See 01-17-3 GENERATOR INSPECTION)</li> <li>Inspect related harness</li> </ul>
31	PSP	PSP switch	Ignition switch ON		B+	<ul style="list-style-type: none"> <li>Inspect PSP switch (See 01-40B-44 POWER STEERING PRESSURE (PSP) SWITCH INSPECTION [FS])</li> <li>Inspect power steering system</li> <li>Inspect related harness</li> </ul>
			Idle	Steering wheel at straight ahead position	B+	
				While turning steering wheel	Below 1.0	
32*1	R position	TR switch (terminal C)	Ignition switch ON	Selector lever is at R position	B+	<ul style="list-style-type: none"> <li>Inspect TR switch (See 05-17-20 TRANSAXLE RANGE (TR) SWITCH INSPECTION)</li> <li>Inspect related harness</li> </ul>
				Selector lever is at other than R position	Below 1.0	
33	—	—	—		—	—
34	BARO/EGR boost	EGR boost sensor	Ignition switch ON (Barometric pressure at 102 kPa {765 mmHg, 30 inHg})		Approx. 4.0	<ul style="list-style-type: none"> <li>Inspect EGR boost sensor (See 01-40B-39 EGR BOOST SENSOR INSPECTION [FS])</li> <li>Inspect related harness</li> </ul>
35	Catalytic converter efficiency	HO2S (Rear)	Ignition switch ON		Below 1.0	<ul style="list-style-type: none"> <li>Inspect HO2S (Rear) (See 01-40B-37 HO2S (Front and Rear) Voltage Inspection)</li> <li>Inspect related harness</li> </ul>
			Idle	Engine cold	Approx. 0	
				After warm up	0.1—0.9	
36	—	—	—		—	—
37*1	TFT	TFT sensor	Ignition switch ON	TFT 20 °C {68 °F}	3—4	<ul style="list-style-type: none"> <li>Inspect TFT sensor (See 05-17-25 TRANSAXLE FLUID TEMPERATURE (TFT) SENSOR INSPECTION)</li> <li>Inspect related harness</li> </ul>
				TFT 130 °C {266 °F}	0.2—0.7	
38	ECT	ECT sensor	Ignition switch ON	ECT 20 °C {68 °F}	2.9—3.1	<ul style="list-style-type: none"> <li>Inspect ECT sensor (See 01-40B-31 ENGINE COOLANT TEMPERATURE (ECT) SENSOR INSPECTION [FS])</li> <li>Inspect related harness</li> </ul>
				After warm up	0.2—1.0	

01-40B

## CONTROL SYSTEM [FS]

Terminal	Signal	Connected to	Test condition		Voltage (V)	Action
39	IAT	IAT sensor (integrated with MAF sensor)	Ignition switch ON	IAT 20 °C {68 °F}	2.3—2.4	<ul style="list-style-type: none"> <li>Inspect IAT sensor (See 01-40B-27 INTAKE AIR TEMPERATURE (IAT) SENSOR INSPECTION [FS])</li> <li>Inspect related harness</li> </ul>
				IAT 30 °C {86 °F}	1.7—1.9	
40	—	—	—		—	—
41	A/C on signal	Refrigerant pressure switch	Idle	A/C switch and fan switch on	Below 1.0	<ul style="list-style-type: none"> <li>Inspect A/C switch (See 07-40-9 REFRIGERANT PRESSURE SWITCH INSPECTION)</li> <li>Inspect related harness</li> </ul>
				A/C switch off	B+	
42	Generator warning light control	Generator warning light (in instrument cluster)	Ignition switch ON		Below 1.0	<ul style="list-style-type: none"> <li>Inspect generator warning light</li> <li>Inspect related harness</li> </ul>
			Idle		B+	
43*1	O/D OFF indicator light signal	O/D OFF indicator light	Ignition switch ON	O/D OFF indicator light illuminates	Below 1.0	<ul style="list-style-type: none"> <li>Inspect O/D OFF indicator light</li> <li>Inspect related harness</li> </ul>
				O/D OFF indicator light does not illuminate	B+	
44*1	Pressure control solenoid control (+)	Pressure control solenoid	<ul style="list-style-type: none"> <li>Inspect using the wave profile. (See 01-40B-22 Inspection Using An Oscilloscope (Reference))</li> </ul>			<ul style="list-style-type: none"> <li>Inspect pressure control solenoid (See 05-17-28 SOLENOID VALVES INSPECTION)</li> <li>Inspect related harness</li> </ul>
45	Condenser fan control	Condenser fan relay	Ignition switch ON		B+	<ul style="list-style-type: none"> <li>Inspect condenser fan relay (See 09-21-5 RELAY INSPECTION)</li> <li>Inspect related harness</li> </ul>
			Idle	Condenser fan operating	Below 1.0	
				Others	B+	
46	EGR valve #3 coil control	EGR valve (terminal B)	Ignition switch ON		B+	<ul style="list-style-type: none"> <li>Inspect EGR valve (See 01-16-15 EGR VALVE INSPECTION)</li> <li>Inspect related harness</li> </ul>
			Idle		B+	
47	Cooling fan control	Cooling fan relay	Ignition switch ON		B+	<ul style="list-style-type: none"> <li>Inspect cooling fan relay (See 09-21-5 RELAY INSPECTION)</li> <li>Inspect related harness</li> </ul>
			Idle	Cooling fan operating	Below 1.0	
				Others	B+	
48	Engine speed	Tachometer (in instrument cluster), DLC terminal IG-	<ul style="list-style-type: none"> <li>Inspect using the wave profile. (See 01-40B-22 Inspection Using An Oscilloscope (Reference))</li> </ul>			<ul style="list-style-type: none"> <li>Inspect tachometer (See 09-22-4 Tachometer)</li> <li>Inspect related harness</li> </ul>
49	—	—	—		—	—
50	—	—	—		—	—
51	GND	GND	Under any condition		Below 1.0	<ul style="list-style-type: none"> <li>Inspect related harness</li> </ul>

## CONTROL SYSTEM [FS]

Terminal	Signal	Connected to	Test condition	Voltage (V)	Action
52	IGT2	Ignition coil (No. 2, 3 cylinders)	<ul style="list-style-type: none"> <li>Inspect using the wave profile. (See 01-40B-22 Inspection Using An Oscilloscope (Reference))</li> </ul>		<ul style="list-style-type: none"> <li>Inspect ignition coil (See 01-18-2 IGNITION COIL INSPECTION)</li> <li>Inspect related harness</li> </ul>
53	Generator field coil control	Generator (terminal D)	<ul style="list-style-type: none"> <li>Inspect using the wave profile. (See 01-40B-22 Inspection Using An Oscilloscope (Reference))</li> </ul>		<ul style="list-style-type: none"> <li>Inspect generator (See 01-17-3 GENERATOR INSPECTION)</li> <li>Inspect related harness</li> </ul>
54	IAC (+)	IAC valve	Ignition switch ON	B+	<ul style="list-style-type: none"> <li>Inspect IAC valve (See 01-13B-8 IDLE AIR CONTROL (IAC) VALVE INSPECTION [FS])</li> <li>Inspect related harness</li> </ul>
			Idle (After warm up and E/L off)	B+	
55	Back-up power supply	Battery (positive terminal)	Under any condition	B+	<ul style="list-style-type: none"> <li>Inspect battery (See 01-17-1 BATTERY INSPECTION)</li> <li>Inspect EGI fuse</li> <li>Inspect related harness</li> </ul>
56	EGR valve #4 coil control	EGR valve (terminal F)	Ignition switch ON	Below 1.0	<ul style="list-style-type: none"> <li>Inspect EGR valve (See 01-16-15 EGR VALVE INSPECTION)</li> <li>Inspect related harness</li> </ul>
			Idle	Below 1.0	
57	Knocking	Knock sensor (+)	Ignition switch ON (Use digital type voltmeter, because measurement voltage will be detected less than true voltage when using analog type voltmeter)	Below 1.0	<ul style="list-style-type: none"> <li>Inspect knock sensor (See 01-40B-36 KNOCK SENSOR INSPECTION [FS])</li> <li>Inspect related harness</li> </ul>
58	Vehicle speed	Speedometer (MTX)	<ul style="list-style-type: none"> <li>Inspect using the wave profile. (See 01-40B-22 Inspection Using An Oscilloscope (Reference))</li> </ul>		<ul style="list-style-type: none"> <li>Inspect VSS (See 09-22-4 Speedometer)</li> <li>Inspect related harness</li> </ul>
		VSS (ATX)			<ul style="list-style-type: none"> <li>Inspect VSS (See 05-17-27 VEHICLE SPEEDOMETER SENSOR (VSS) INSPECTION [ATX])</li> <li>Inspect related harness</li> </ul>
59	Knocking	Knock sensor (-)	Ignition switch ON (Use digital type voltmeter, because measurement voltage will be detected less than true voltage when using analog type voltmeter)	Below 1.0	<ul style="list-style-type: none"> <li>Inspect knock sensor (See 01-40B-36 KNOCK SENSOR INSPECTION [FS])</li> <li>Inspect related harness</li> </ul>
60	HO2S (Front)	HO2S (Front)	Ignition switch ON	0—1.0	<ul style="list-style-type: none"> <li>Inspect HO2S (Front) (See 01-40B-37 HO2S (Front and Rear) Voltage Inspection)</li> <li>Inspect related harness</li> </ul>
			Idle	0—1.0	
			Acceleration	0.5—1.0	
			Deceleration	0—0.5	
61	—	—	—	—	—

01-40B



## CONTROL SYSTEM [FS]

Terminal	Signal	Connected to	Test condition		Voltage (V)	Action	
62	Fuel tank pressure	Fuel tank pressure sensor	Ignition switch ON	Fuel tank pressure 0 kPa {0 mmHg, 0 inHg}	Approx. 2.5	<ul style="list-style-type: none"> <li>Inspect fuel tank pressure sensor (See 01-40B-40 FUEL TANK PRESSURE SENSOR INSPECTION [FS])</li> <li>Inspect related harness</li> </ul>	
				Fuel tank pressure 1 kPa {7.5 mmHg, 0.3 inHg}	Approx. 2.8		
63	Fuel tank level	Fuel gauge sender unit	Full fuel		0.2—0.5	<ul style="list-style-type: none"> <li>Inspect fuel gauge sender unit (See 09-22-4 Fuel Gauge)</li> <li>Inspect related harness</li> </ul>	
			Half fuel		2.0—2.8		
			Empty fuel		3.4—4.4		
64	Neutral position (MTX)	Neutral switch	Shift lever is at neutral position		Below 1.0	<ul style="list-style-type: none"> <li>Inspect neutral switch (See 01-40B-43 NEUTRAL SWITCH INSPECTION [FS])</li> <li>Inspect related harness</li> </ul>	
			Shift lever is not at neutral position		B+		
	Load/no load signal (ATX)	TR switch (terminal H)	Ignition switch ON	Selector lever is at P or N position		Below 1.0	<ul style="list-style-type: none"> <li>Inspect TR switch (See 05-17-20 TRANSAXLE RANGE (TR) SWITCH INSPECTION)</li> <li>Inspect related harness</li> </ul>
				Others		B+	
65	—	—	—	—	—	—	
66	—	—	—	—	—	—	
67	Purge control	Purge solenoid valve	<ul style="list-style-type: none"> <li>Inspect using the wave profile. (See 01-40B-22 Inspection Using An Oscilloscope (Reference))</li> </ul>			<ul style="list-style-type: none"> <li>Inspect purge solenoid valve (See 01-16-12 PURGE SOLENOID VALVE INSPECTION)</li> <li>Inspect related harness</li> </ul>	
68	EGR valve #1 coil control	EGR valve (terminal E)	Ignition switch ON		Below 1.0	<ul style="list-style-type: none"> <li>Inspect EGR valve (See 01-16-15 EGR VALVE INSPECTION)</li> <li>Inspect related harness</li> </ul>	
			Idle		Below 1.0		
69	—	—	—	—	—	—	
70	—	—	—	—	—	—	
71	Power supply	Main relay	Ignition switch ON		B+	<ul style="list-style-type: none"> <li>Inspect main relay (See 09-21-5 RELAY INSPECTION)</li> <li>Inspect EGI fuse</li> <li>Inspect related harness</li> </ul>	
			Ignition switch OFF		Below 1.0		
72	EGR valve #2 coil control	EGR valve (terminal A)	Ignition switch ON		B+	<ul style="list-style-type: none"> <li>Inspect EGR valve (See 01-16-15 EGR VALVE INSPECTION)</li> <li>Inspect related harness</li> </ul>	
			Idle		B+		
73	VTCS control	VTCS solenoid valve	ECT above 67.5 °C {154 °F} while idling		B+	<ul style="list-style-type: none"> <li>Inspect VTCS solenoid valve (See 01-13B-15 VARIABLE TUMBLE CONTROL SYSTEM (VTCS) SOLENOID VALVE INSPECTION [FS])</li> <li>Inspect related harness</li> </ul>	
			ECT below 67.5 °C {154 °F} and engine speed below 3,250 rpm		Below 1.0		

## CONTROL SYSTEM [FS]

Terminal	Signal	Connected to	Test condition	Voltage (V)	Action
74	Fuel injection (#3)	Fuel injector No.3	<ul style="list-style-type: none"> <li>Inspect using the wave profile. (See 01-40B-22 Inspection Using An Oscilloscope (Reference))</li> </ul>		<ul style="list-style-type: none"> <li>Inspect fuel injector No.3 (See 01-14-24 FUEL INJECTOR INSPECTION)</li> <li>Inspect related harness</li> </ul>
75	Fuel injection (#1)	Fuel injector No.1	<ul style="list-style-type: none"> <li>Inspect using the wave profile. (See 01-40B-22 Inspection Using An Oscilloscope (Reference))</li> </ul>		<ul style="list-style-type: none"> <li>Inspect fuel injector No.1 (See 01-14-24 FUEL INJECTOR INSPECTION)</li> <li>Inspect related harness</li> </ul>
76	GND	GND	Under any condition	Below 1.0	<ul style="list-style-type: none"> <li>Inspect related harness</li> </ul>
77	GND	GND	Under any condition	Below 1.0	<ul style="list-style-type: none"> <li>Inspect related harness</li> </ul>
78	—	—	—	—	—
79	K-LINE (serial communication)	DLC terminal KLN	Because this terminal is for serial communication, good/no good judgment by terminal voltage is not possible.		<ul style="list-style-type: none"> <li>Inspect related harness</li> </ul>
80	Fuel pump control	Fuel pump relay	Ignition switch ON	B+	<ul style="list-style-type: none"> <li>Inspect fuel pump relay (See 09-21-5 RELAY INSPECTION)</li> <li>Inspect related harness</li> </ul>
			Cranking	Below 1.0	
			Idle	Below 1.0	
81*1	Pressure control solenoid control (-)	Pressure control solenoid	<ul style="list-style-type: none"> <li>Inspect using the wave profile. (See 01-40B-22 Inspection Using An Oscilloscope (Reference))</li> </ul>		<ul style="list-style-type: none"> <li>Inspect pressure control solenoid (See 05-17-28 SOLENOID VALVES INSPECTION)</li> <li>Inspect related harness</li> </ul>
82*1	Shift solenoid A control	Shift solenoid A	<ul style="list-style-type: none"> <li>Inspect using the wave profile. (See 01-40B-22 Inspection Using An Oscilloscope (Reference))</li> </ul>		<ul style="list-style-type: none"> <li>Inspect shift solenoid A (See 05-17-28 SOLENOID VALVES INSPECTION)</li> <li>Inspect related harness</li> </ul>
83	IAC (-)	IAC valve	<ul style="list-style-type: none"> <li>Inspect using the wave profile. (See 01-40B-22 Inspection Using An Oscilloscope (Reference))</li> </ul>		<ul style="list-style-type: none"> <li>Inspect IAC valve (See 01-13B-8 IDLE AIR CONTROL (IAC) VALVE INSPECTION [FS])</li> <li>Inspect related harness</li> </ul>
84*1	Input/turbine speed (+)	Input/turbine speed sensor	<ul style="list-style-type: none"> <li>Inspect using the wave profile. (See 01-40B-22 Inspection Using An Oscilloscope (Reference))</li> </ul>		<ul style="list-style-type: none"> <li>Inspect input/turbine speed sensor (See 05-17-26 INPUT/TURBINE SPEED SENSOR INSPECTION)</li> <li>Inspect related harness</li> </ul>
85	SGC(+)	CMP sensor	<ul style="list-style-type: none"> <li>Inspect using the wave profile. (See 01-40B-22 Inspection Using An Oscilloscope (Reference))</li> </ul>		<ul style="list-style-type: none"> <li>Inspect CMP sensor (See 01-40B-35 CAMSHAFT POSITION (CMP) SENSOR INSPECTION [FS])</li> <li>Inspect related harness</li> </ul>

01-40B

## CONTROL SYSTEM [FS]

Terminal	Signal	Connected to	Test condition	Voltage (V)	Action	
86	SGC(-)	CMP sensor	<ul style="list-style-type: none"> <li>Inspect using the wave profile. (See 01-40B-22 Inspection Using An Oscilloscope (Reference))</li> </ul>		<ul style="list-style-type: none"> <li>Inspect CMP sensor (See 01-40B-35 CAMSHAFT POSITION (CMP) SENSOR INSPECTION [FS])</li> <li>Inspect related harness</li> </ul>	
87	—	—	—	—	—	
88	MAF	MAF sensor	Ignition switch ON	0.9—2.0	<ul style="list-style-type: none"> <li>Inspect MAF sensor (See 01-40B-28 MASS AIR FLOW (MAF) SENSOR INSPECTION [FS])</li> <li>Inspect related harness</li> </ul>	
			Idle	1.7—2.4		
89	Throttle position	TP sensor	Ignition switch ON	CTP	0.1—1.1	<ul style="list-style-type: none"> <li>Inspect TP sensor (See 01-40B-29 THROTTLE POSITION (TP) SENSOR INSPECTION [FS])</li> <li>Inspect related harness</li> </ul>
				WOT	3.0—4.6	
90	Constant voltage (Vref)	TP sensor, EGR boost sensor, Fuel tank pressure sensor	Ignition switch ON	Approx. 5.0	<ul style="list-style-type: none"> <li>Inspect related harness</li> </ul>	
91	Sensor GND	ECT sensor, IAT sensor, EGR boost sensor, Fuel tank pressure sensor, TP sensor, HO2S (Front, Rear), TFT sensor	Under any condition	Below 1.0	<ul style="list-style-type: none"> <li>Inspect related harness</li> </ul>	
92	Brake	Brake switch	Brake pedal depressed	B+	<ul style="list-style-type: none"> <li>Inspect brake switch (See 04-11-5 BRAKE SWITCH INSPECTION)</li> <li>Inspect related harness</li> </ul>	
			Brake pedal released	Below 1.0		
93	HO2S (Rear) heater control	HO2S (Rear)	Idle	ECT above 70°C {158 °F}	Below 1.0	<ul style="list-style-type: none"> <li>Inspect HO2S (Rear) (See 01-40B-38 HO2S Heater (Front and Rear) Resistance Inspection)</li> <li>Inspect related harness</li> </ul>
				HO2S (Rear) is malfunctioning	B+	
94	HO2S (Front) heater control	HO2S (Front)	Ignition switch ON (engine stopped)	B+	<ul style="list-style-type: none"> <li>Inspect HO2S (Front) heater. (See 01-40B-38 HO2S Heater (Front and Rear) Resistance Inspection)</li> <li>Inspect related harness</li> </ul>	
			Approx. 15 s after engine start with ECT 20—30°C {68—86 °F}	Below 1.0		
			Others	Below 1.0 ↔ B+		
95	PRC	PRC solenoid valve	Ignition switch ON	B+	<ul style="list-style-type: none"> <li>Inspect PRC solenoid valve (See 01-14-31 PRC SOLENOID VALVE INSPECTION)</li> <li>Inspect related harness</li> </ul>	
			After hot start	Below 1.0		

## CONTROL SYSTEM [FS]

Terminal	Signal	Connected to	Test condition	Voltage (V)	Action	
96	A/C control	A/C relay	Idle	A/C switch and fan switch on	Below 1.0	<ul style="list-style-type: none"> <li>Inspect A/C relay (See 09-21-5 RELAY INSPECTION)</li> <li>Inspect related harness</li> </ul>
				A/C switch off	B+	
97	Power supply	Main relay	Ignition switch ON	B+	<ul style="list-style-type: none"> <li>Inspect main relay (See 09-21-5 RELAY INSPECTION)</li> <li>Inspect related harness</li> </ul>	
			Ignition switch off	Below 1.0		
98	EGR boost sensor switching control	EGR boost solenoid valve	Ignition switch ON	B+	<ul style="list-style-type: none"> <li>Inspect EGR boost solenoid valve (See 01-16-17 EGR BOOST SENSOR SOLENOID VALVE INSPECTION)</li> <li>Inspect related harness</li> </ul>	
			Idle	B+		
99*1	Shift solenoid B control	Shift solenoid B	<ul style="list-style-type: none"> <li>Inspect using the wave profile. (See 01-40B-22 Inspection Using An Oscilloscope (Reference))</li> </ul>		<ul style="list-style-type: none"> <li>Inspect shift solenoid B (See 05-17-28 SOLENOID VALVES INSPECTION)</li> <li>Inspect related harness</li> </ul>	
100	Fuel injection (#4)	Fuel injector No.4	<ul style="list-style-type: none"> <li>Inspect using the wave profile. (See 01-40B-22 Inspection Using An Oscilloscope (Reference))</li> </ul>		<ul style="list-style-type: none"> <li>Inspect fuel injector No.4 (See 01-14-24 FUEL INJECTOR INSPECTION)</li> <li>Inspect related harness</li> </ul>	
101	Fuel injection (#2)	Fuel injector No.2	<ul style="list-style-type: none"> <li>Inspect using the wave profile. (See 01-40B-22 Inspection Using An Oscilloscope (Reference))</li> </ul>		<ul style="list-style-type: none"> <li>Inspect fuel injector No.2 (See 01-14-24 FUEL INJECTOR INSPECTION)</li> <li>Inspect related harness</li> </ul>	
102*1	Shift solenoid C Control	Shift solenoid C	<ul style="list-style-type: none"> <li>Inspect using the wave profile. (See 01-40B-22 Inspection Using An Oscilloscope (Reference))</li> </ul>		<ul style="list-style-type: none"> <li>Inspect shift solenoid C (See 05-17-28 SOLENOID VALVES INSPECTION)</li> <li>Inspect related harness</li> </ul>	
103	GND	GND	Under any condition	Below 1.0	<ul style="list-style-type: none"> <li>Inspect related harness</li> </ul>	
104	—	—	—	—	—	

\*1 : ATX only

01-40B

# CONTROL SYSTEM [FS]

## Inspection Using An Oscilloscope (Reference)

### Ne signal

- PCM terminal: 21(+)-22(-)
- Oscilloscope setting: 2 V/DIV(Y), 2 ms/DIV(X), DC range
- Vehicle condition: idle after warm up



Z3U0140W006

### IGT signal

- PCM terminal:
  - IGT1: 26(+)-103(-)
  - IGT2: 52(+)-103(-)
- Oscilloscope setting: 1 V/DIV(Y), 10ms/DIV(X), DC range
- Vehicle condition: idle after warm up

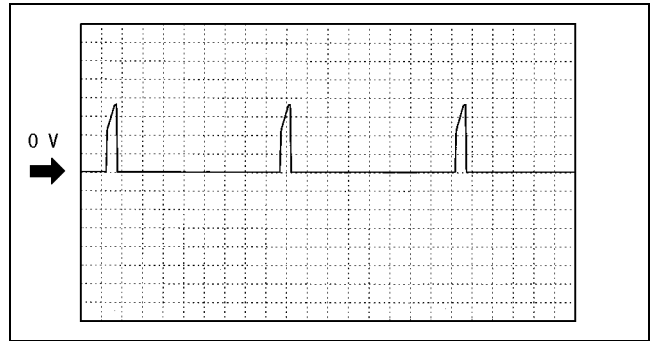

Z3U0140W007

### Input/turbine speed signal

- PCM terminal: 84(+)-23(-)
- Oscilloscope setting: 0.4 V/DIV(Y), 2.5 ms/DIV(X), DC range
- Vehicle condition: idle after warm up

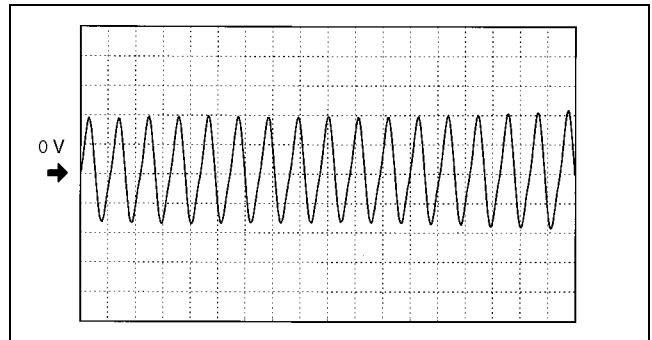

Z3U0140W008

### Generator output voltage signal

- PCM terminal: 30(+)-103(-)
- Oscilloscope setting: 2 V/DIV(Y), 5 ms/DIV(X), DC range
- Vehicle condition: idle after warm up

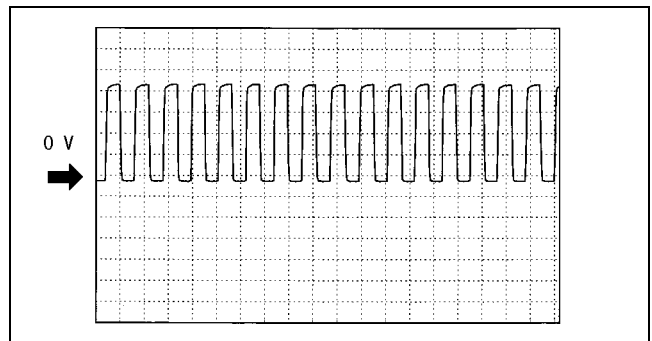

Z3U0140W009

## Pressure control solenoid control signal

### CTP

- PCM terminal: 81(+)-103(-)
- Oscilloscope setting: 0.5 V/DIV(Y), 0.1 ms/DIV(X), DC range
- Vehicle condition: ignition key at ON (Engine OFF) and closed throttle position

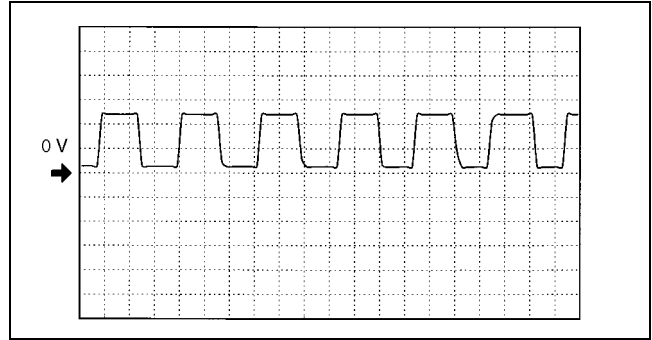

Z3U0140W010

01-40B

### WOT

- PCM terminal: 81(+)-103(-)
- Oscilloscope setting: 0.5 V/DIV(Y), 0.1 ms/DIV(X), DC range
- Vehicle condition: ignition key at ON (Engine OFF) and wide open throttle

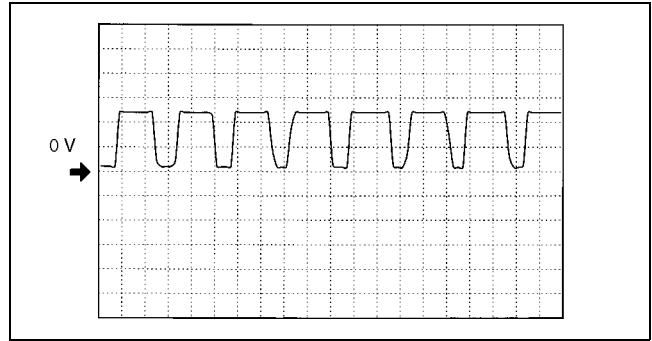

Z3U0140W019

## Engine speed signal

- PCM terminal: 48(+)-103(-)
- Oscilloscope setting: 2 V/DIV(Y), 20 ms/DIV(X), DC range
- Vehicle condition: idle after warm up

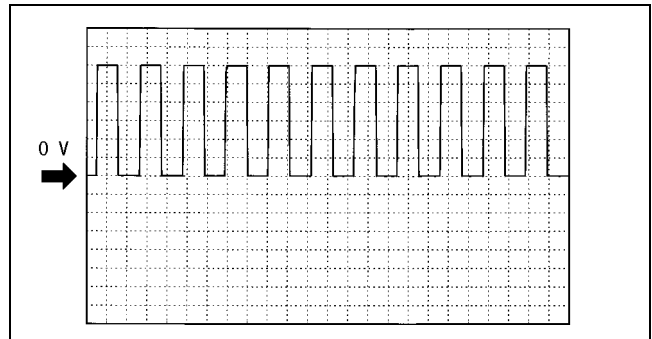

Z3U0140W011

## Generator field coil control signal

- PCM terminal: 53(+)-103(-)
- Oscilloscope setting: 0.2 V/DIV(Y), 2ms/DIV(X), DC range
- Vehicle condition: idle after warm up

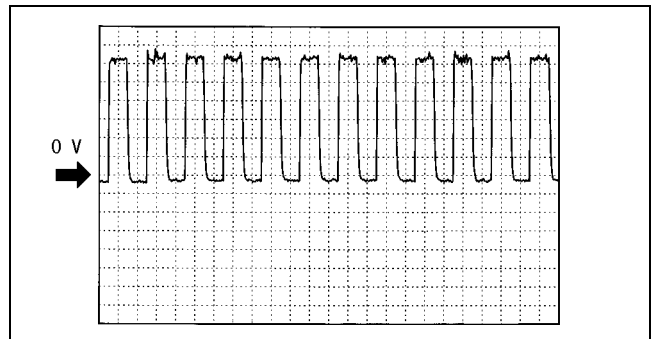

Z3U0140W012

## CONTROL SYSTEM [FS]

### Vehicle speed signal

- PCM terminal: 58(+)-103(-)
- Oscilloscope setting: 1 V/DIV(Y), 2.5 ms/DIV(X), DC range
- Vehicle condition: drive the vehicle with 32 km/h [20 mph]

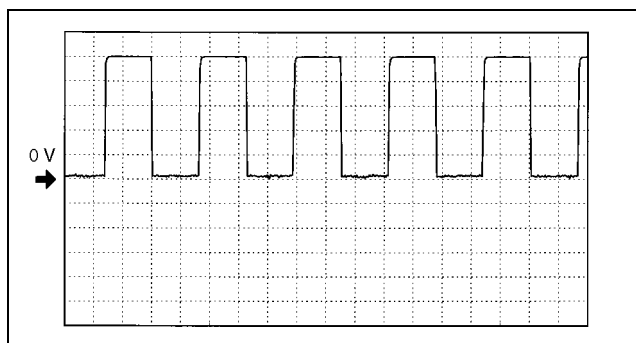

Z3U0140W013

### Purge control signal

- PCM terminal: 67(+)-103(-)
- Oscilloscope setting: 4 V/DIV(Y), 20 ms/DIV(X), DC range
- Vehicle condition: idle after warm up

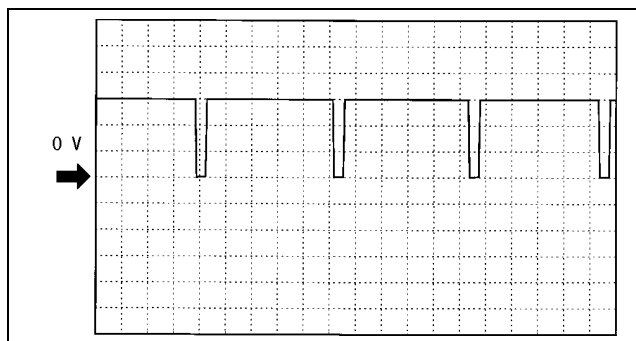

Z3U0140W014

### Fuel injection signal

- PCM terminal
  - No.1:75(+)-103(-)
  - No.2:101(+)-103(-)
  - No.3:74(+)-103(-)
  - No.4:100(+)-103(-)
- Oscilloscope setting: 2 V/DIV(Y), 5 ms/DIV(X), DC range
- Vehicle condition: idle after warm up

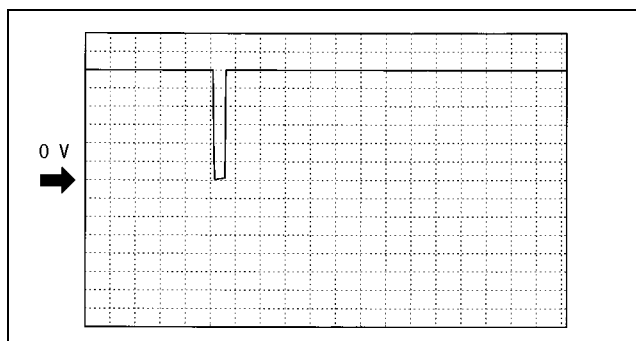

Z3U0140W015

### Shift solenoid A control

- PCM terminal: 82(+)-103(-)
- Oscilloscope setting: 5 V/DIV(Y), 5 ms/DIV(X), DC range
- Vehicle condition: drive in the 4th gear

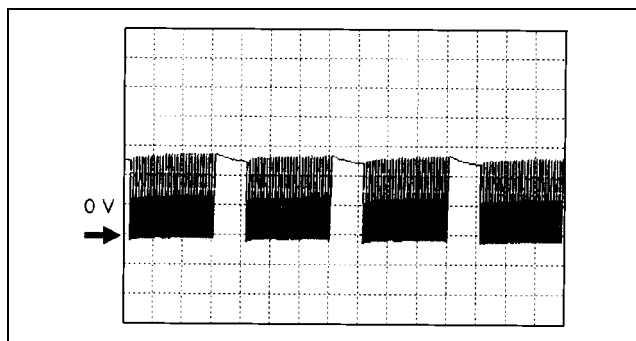

Z3U0140W016

## IAC signal

- PCM terminal: 83(+)-103(-)
- Oscilloscope setting: 2 V/DIV(Y), 0.5 ms/DIV(X), DC range
- Vehicle condition: idle after warm up

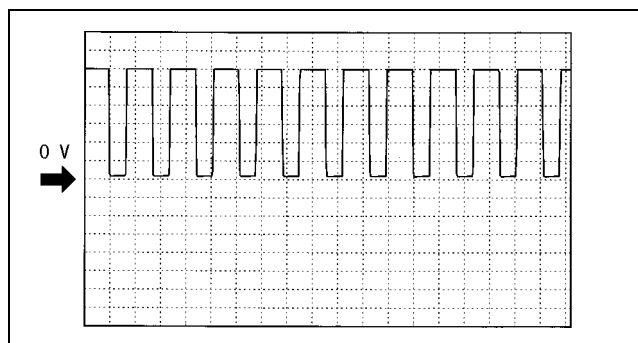

Z3U0140W017

01-40B

## SGC signal

- PCM terminal: 85(+)-86(-)
- Oscilloscope setting: 1 V/DIV(Y), 10 ms/DIV(X), AC range
- Vehicle condition: idle after warm up

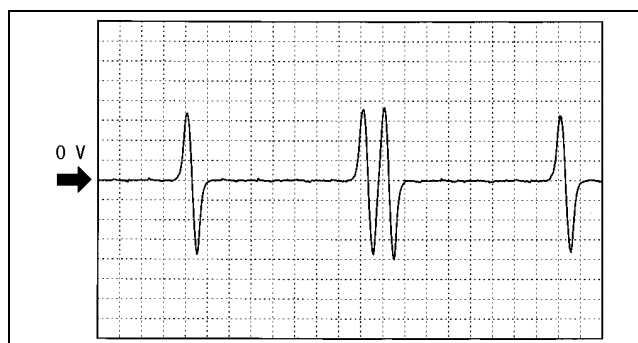

Z3U0140W032

## Shift solenoid B control signal

- PCM terminal: 99(+)-103(-)
- Oscilloscope setting: 5 V/DIV(Y), 5ms/DIV(X), DC range
- Vehicle condition: Drive in D range, 1st gear

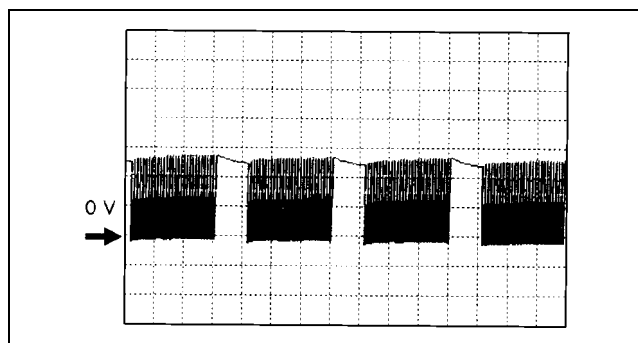

Z3U0140W016

## Shift solenoid C control signal

- PCM terminal: 102(+)-103(-)
- Oscilloscope setting: 5 V/DIV(Y), 5 ms/DIV(X), DC range
- Vehicle condition: Drive in 1st or 2nd gear

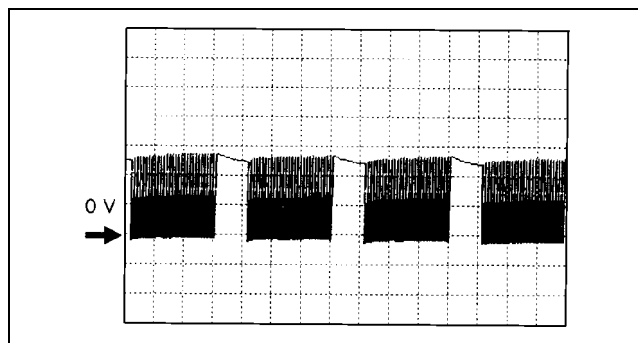

Z3U0140W016



# CONTROL SYSTEM [FS]

## INSPECTION USING AN OSCILLOSCOPE (REFERENCE) [FS]

A3U014018881W04

### Purpose

The use of oscilloscope makes the inspection of a part such as a stuck solenoid valve possible without actually removing parts.

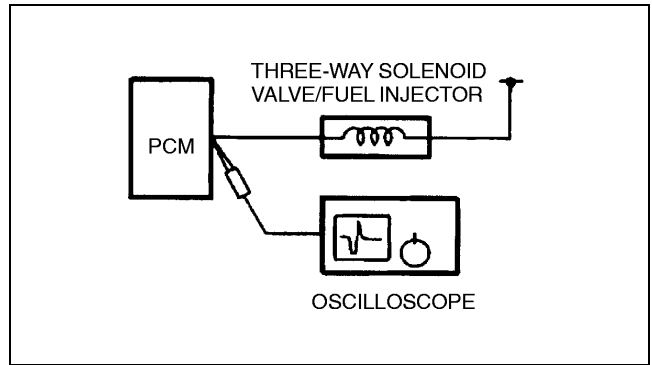

X3U101WNT

### When Normal

Counter electromotive voltage A, generated when the three-way solenoid valve or the fuel injector is turned off from on, shows irregular convergence because induced electromotive voltage B, generated by the plunger return operation, is added to it.

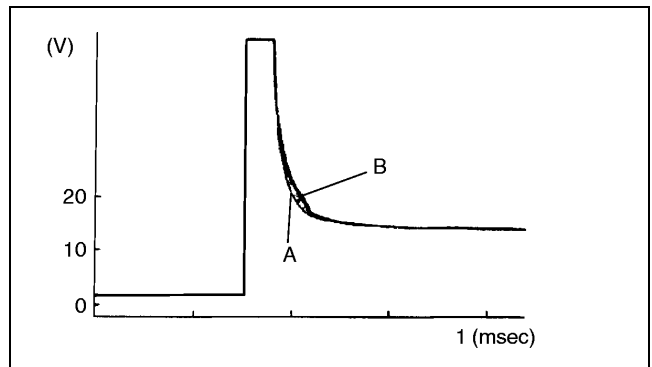

X3U101WNU

### When Plunger Stuck

When the plunger is stuck, pulse convergence is smooth because no induced electromotive voltage B is generated.

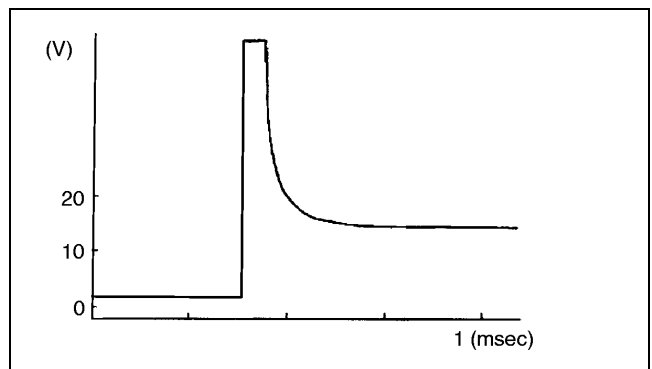

X3U101WNV

## INTAKE AIR TEMPERATURE (IAT) SENSOR INSPECTION [FS]

A3U014018845W01

### Resistance Inspection

#### Note

- Perform the following test only when directed.

1. Remove the IAT sensor.
2. Measure the resistance of the IAT sensor terminals A and B using an ohmmeter.
  - If not as specified, replace the IAT sensor.
  - If IAT sensor is okay, but PID value or PCM terminal 39 voltage is out of specification, carry out the "Circuit Open/Short Inspection".

#### Specification

Ambient temperature (°C {°F})	Resistance (kilohm)
20 {68}	2.0—2.9
80 {176}	0.27—0.37

#### IAT sensor signal characteristic (reference)

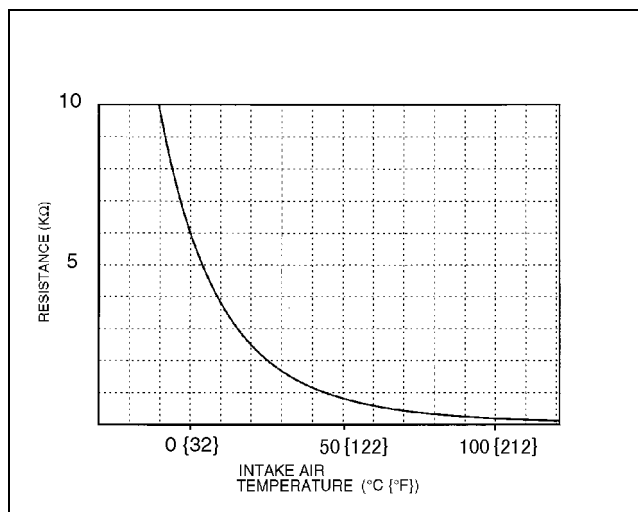

Z3U0140W021

#### Circuit Open/Short Inspection

1. Disconnect the PCM connector. (See 01-40B-7 PCM REMOVAL/INSTALLATION [FS].)
2. Connect the **SST** (104 Pin Breakout Box) to the PCM as shown.
3. Tighten the connector attaching screw.

#### Tightening torque

**7.9—10.7 N·m**  
**{80—110 kgf·cm, 69.5—95.4 in·lbf}**

4. Inspect for an open or short circuit in the following wiring harnesses by probing the applicable sensor and **SST** (104 Pin Breakout Box) terminals with ohmmeter leads.
  - If there is an open or short circuit, repair or replace wiring harnesses.
  - If there is no open or short circuit, replace the IAT sensor.

#### Open circuit

- IAT signal circuit (IAT sensor connector terminal A and PCM connector terminal 39)
- GND circuit (IAT sensor connector terminal B and PCM connector terminal 91)

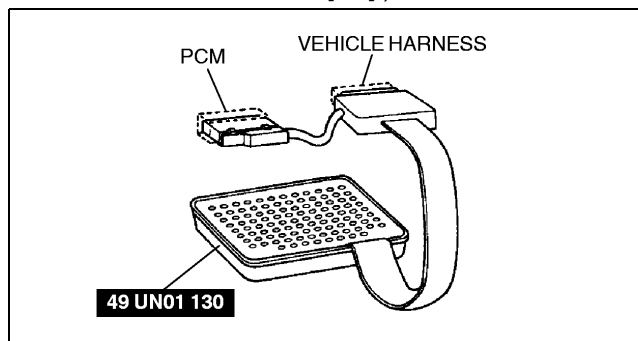

X3U140WE8

## CONTROL SYSTEM [FS]

### Short circuit

- IAT signal circuit (IAT sensor connector terminal A and PCM connector terminal 39 to GND)
5. Install the IAT sensor.

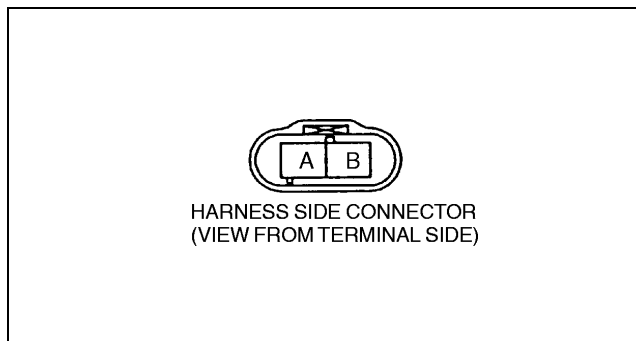

Y3U140WB1

### MASS AIR FLOW (MAF) SENSOR INSPECTION [FS]

A3U014013210W01

#### Note

- Perform the following test only when directed.
- Visually inspect for damage, cracks, terminal bends and terminal rust on the MAF sensor.
    - If any of the above is found, replace the MAF sensor.
    - If the MAF sensor is okay, but PID value or PCM terminal 88 voltage is out of specification, carry out the "Circuit Open/Short Inspection".

### Circuit Open/Short Inspection

- Remove the PCM. (See 01-40B-7 PCM REMOVAL/INSTALLATION [FS].)
- Connect the **SST** (104 Pin Breakout Box) to the PCM as shown.
- Tighten the connector attaching screw.

#### Tightening torque

7.9—10.7 N·m

{80—110 kgf·cm, 69.5—95.4 in·lbf}

- Inspect for an open or short circuit in the following wiring harnesses by probing the applicable sensor and **SST** (104 Pin Breakout Box) terminals with ohmmeter leads.
  - If there is an open or short circuit, repair or replace wiring harnesses.
  - If there is no open or short circuit, replace the MAF sensor.

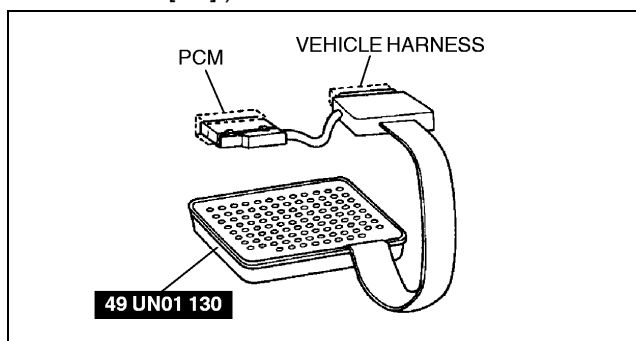

X3U140WE8

### Open circuit

- MAF signal circuit (MAF sensor connector terminal B and PCM connector terminal 88)
- Power circuit (MAF sensor connector terminal C and main relay terminal D through common connector)
- GND circuit (MAF sensor connector terminal A and PCM connector terminal 103 through common connector)

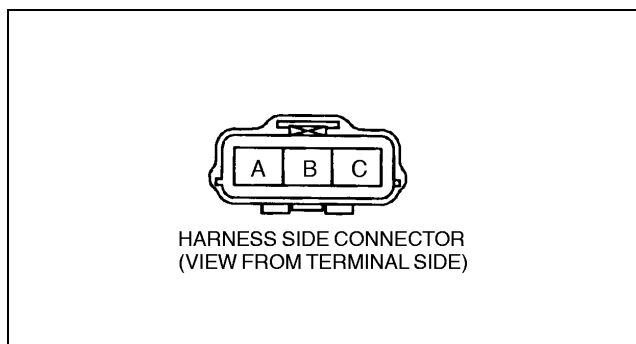

Y3U140WB2

**Short circuit**

- MAF signal circuit (MAF sensor connector terminal B and PCM connector terminal 88 to GND)
- Power circuit (MAF sensor connector terminal C and main relay terminal D through common connector to GND)

5. Reconnect the MAF sensor connector.

**Note**

- The scan tool shows the MAF rate and load value.

**Specification**

	Intake MAF (g/s)		Engine load calculated value (%)	
	MTX	ATX	MTX	ATX
Idle*1	1.6—2.5	1.8—2.6	13.0— 18.0	14.5— 19.0
Engine speed 2,500 rpm*2	6.2—7.4	6.5—7.9	12.5— 17.0	13.0— 17.0

\*1 : 650—750 rpm

\*2 : No load, neutral or P position

**THROTTLE POSITION (TP) SENSOR INSPECTION [FS]**

A3U014018910W01

**Resistance Inspection**

**Note**

- Perform the following test only when directed.

1. Inspect throttle valve CTP and accelerator cable free play (See 01-13B-17 ACCELERATOR CABLE INSPECTION [FS].)
  - If as specified, inspect resistance of the TP sensor.
2. Disconnect the TP sensor connector.
3. Measure the resistance between the TP sensor terminals A and C using an ohmmeter.
  - If not as specified, replace the TP sensor. (See 01-13B-6 INTAKE-AIR SYSTEM REMOVAL/INSTALLATION [FS].)
  - If as specified, but PID value or PCM terminal 89 voltage is out of specification, carry out the "Circuit Open/Short Inspection".

**Specification**

**4—6 kilohms**

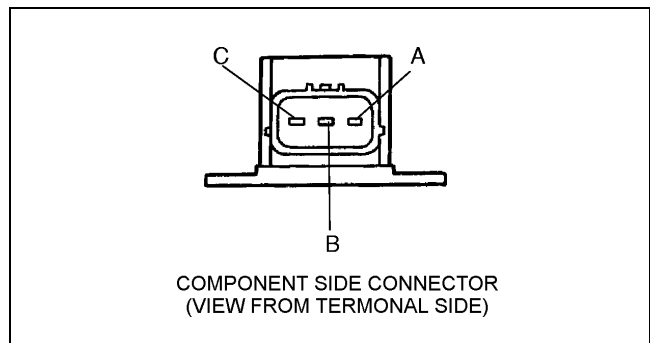

Y3U140WB3

## CONTROL SYSTEM [FS]

### Circuit Open/Short Inspection

1. Remove the PCM. (See 01-40B-7 PCM REMOVAL/INSTALLATION [FS].)
2. Connect the **SST** (104 Pin Breakout Box) to the PCM as shown.
3. Tighten the connector attaching screw.

#### Tightening torque

7.9—10.7 N·m

{80—110 kgf·cm, 69.5—95.4 in·lbf}

4. Inspect for an open or short circuit in the following wiring harnesses by probing the applicable sensor and **SST** (104 Pin Breakout Box) terminals with ohmmeter leads.
  - If there is an open or short circuit, repair or replace wiring harnesses.
  - If there is no open or short circuit, replace the TP sensor.

#### Open circuit

- Constant voltage circuit (TP sensor connector terminal A and PCM connector terminal 90)
- TP signal circuit (TP sensor connector terminal B and PCM connector terminal 89)
- GND circuit (TP sensor connector terminal C and PCM connector terminal 91)

#### Short circuit

- Constant voltage circuit (TP sensor connector terminal A and PCM connector terminal 90)
- TP signal circuit (TP sensor connector terminal B and PCM connector terminal 89)

5. Reconnect the TP sensor connector.

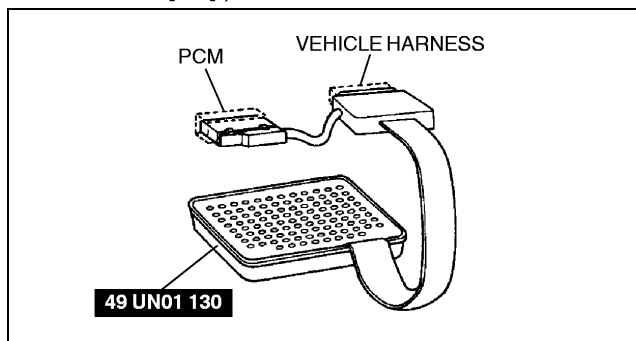

X3U140WE8



HARNESS SIDE CONNECTOR  
(VIEW FROM TERMINAL SIDE)

Y3U140WB4

## ENGINE COOLANT TEMPERATURE (ECT) SENSOR REMOVAL/INSTALLATION [FS]

A3U014018840W01

### Warning

- When the engine is hot, it can badly burn. Turn off the engine and wait until it is cool before removing the ECT sensor.

1. Drain the engine coolant. (See 01-12-2 COOLING SYSTEM SERVICE WARNINGS.) (See 01-12-3 ENGINE COOLANT REPLACEMENT.)
2. Disconnect the ECT sensor connector.
3. Remove the ECT sensor using the **SST**.
4. Replace the gasket.
5. Install in the reverse order of removal.

#### Tightening torque

16—23 N·m

{1.6—2.4 kgf·m, 12—17 ft·lbf}

6. Refill the engine coolant. (See 01-12-2 COOLING SYSTEM SERVICE WARNINGS.) (See 01-12-3 ENGINE COOLANT REPLACEMENT.)

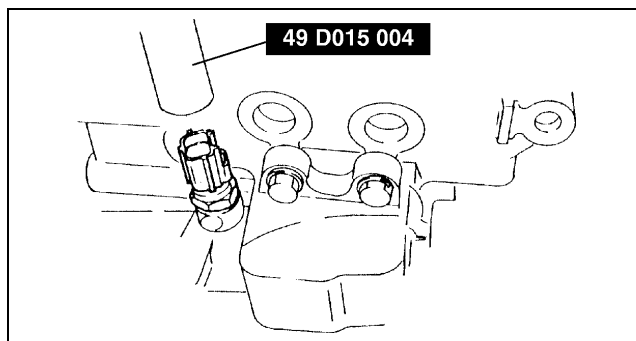

X3U140WDC

# CONTROL SYSTEM [FS]

## ENGINE COOLANT TEMPERATURE (ECT) SENSOR INSPECTION [FS]

A3U014018840W02

### Note

- Perform the following test only when directed.

### ECT Sensor Resistance Inspection

1. Drain the engine coolant. (See 01-12-2 COOLING SYSTEM SERVICE WARNINGS.) (See 01-12-3 ENGINE COOLANT REPLACEMENT.)
2. Remove the ECT sensor.
3. Place the ECT sensor in water with a thermometer, and heat the water gradually.
4. Measure the resistance between the ECT sensor terminals A and B using an ohmmeter.
  - If not as specified, replace the ECT sensor.
  - If the ECT sensor is okay, but PID value or PCM terminal 38 voltage is out of specification, carry out the "Circuit Open/Short Inspection".

### Specification

Water temperature (°C {°F})	Resistance (kilohm)
20 {68}	2.2—2.6
80 {176}	0.29—0.34

01-40B

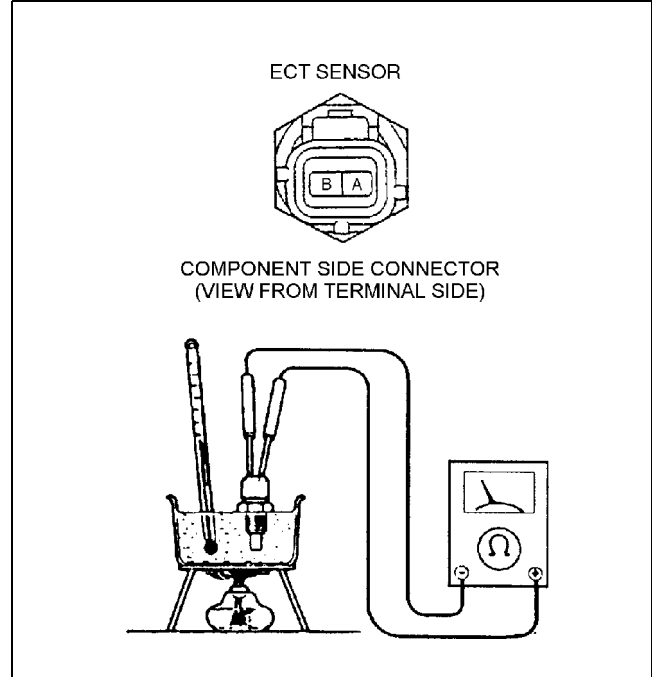

### ECT sensor signal characteristic (reference)

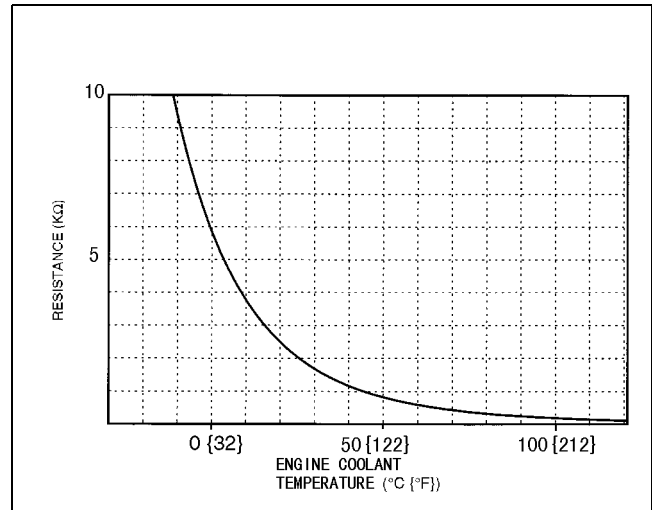

## CONTROL SYSTEM [FS]

### Circuit Open/Short Inspection

1. Remove the PCM. (See 01-40B-7 PCM REMOVAL/INSTALLATION [FS].)
2. Connect the **SST** (104 Pin Breakout Box) to the PCM as shown.
3. Tighten the connector attaching screw.

#### Tightening torque

16—23 N·m

{1.6—2.4 kgf·m, 12—17 ft·lbf}

4. Inspect for an open or short circuit in the following wiring harnesses by probing the applicable sensor and **SST** (104 Pin Breakout Box) terminals with ohmmeter leads.

- If there is an open or short circuit, repair or replace wiring harnesses.
- If there is no open or short circuit, replace the ECT sensor.

#### Open circuit

- ECT signal circuit (ECT sensor connector terminal A and PCM connector terminal 38 through common connector)
- GND circuit (ECT sensor connector terminal B and PCM connector terminal 91)

#### Short circuit

- ECT signal circuit (ECT sensor connector terminal A and PCM connector terminal 38 to GND)

5. Install the ECT sensor.

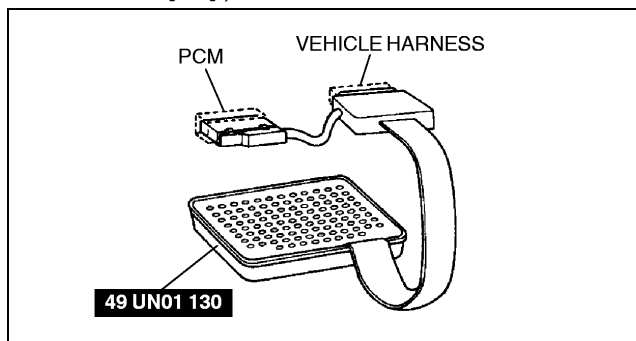

X3U140WE8

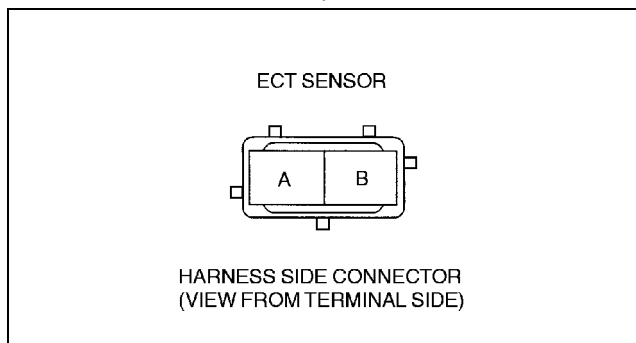

Z3U0140W026

### CRANKSHAFT POSITION (CKP) SENSOR INSPECTION [FS]

A3U014018230W01

#### Air Gap Inspection

##### Note

- Perform the following test only when directed.

1. Verify that the CKP sensor is installed properly.
2. Measure the air gap between the crankshaft pulley teeth and the CKP sensor using a feeler gauge.
  - If not as specified, replace the CKP sensor or inspect the crankshaft pulley teeth for being twisted and/or chipped.
  - If any of the crankshaft pulley teeth is twisted and/or chipped, replace the crankshaft pulley (See 01-10B-10 Crankshaft Pulley Removal Note.)

#### Specification

0.5—1.5 mm {0.020—0.059 in}

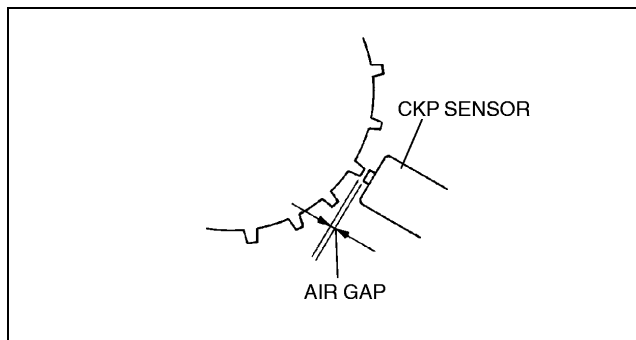

X3U140WDF

## Resistance Inspection

1. Disconnect the CKP sensor connector.
2. Measure the resistance between the CKP sensor terminals A and B using an ohmmeter.
  - If not as specified, replace the CKP sensor.
  - If CKP sensor resistance is okay, but PID value or PCM terminal 21 and 22 voltage is out of specification, carry out the "Circuit Open/Short Inspection".

**Specification**  
Approx. 550 ohms

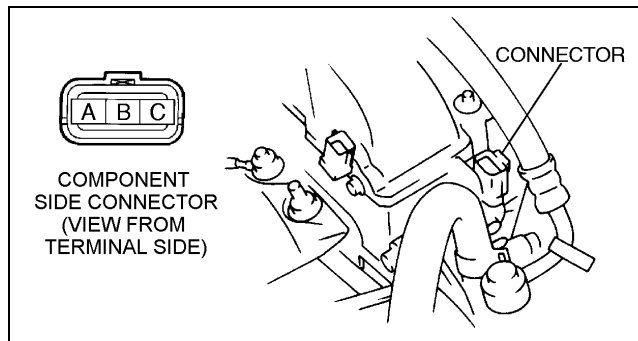

Y3U140WB8

## Circuit Open/Short Inspection

1. Remove the PCM. (See 01-40B-7 PCM REMOVAL/INSTALLATION [FS].)
2. Connect the **SST** (104 Pin Breakout Box) to the PCM as shown.
3. Tighten the connector attaching screw.

**Tightening torque**  
7.9—10.7 N·m  
{80—110 kgf·cm, 69.5—95.4 in·lbf}

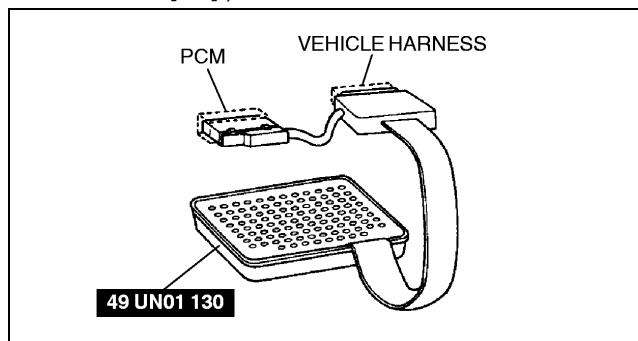

X3U140WE8

4. Inspect for an open or short circuit in the following wiring harnesses by probing the applicable sensor and **SST** (104 Pin Breakout Box) terminals with ohmmeter leads.
  - If there is an open or short circuit, repair or replace wiring harnesses.
  - If there is no open or short circuit, replace the CKP sensor.

### Open circuit

- CKP signal circuit (CKP sensor connector terminal A and PCM connector terminal 21)
- CKP signal circuit (CKP sensor connector terminal B and PCM connector terminal 22)

### Short circuit

- CKP signal circuit (CKP sensor connector terminal A and PCM connector terminal 21 to GND)
- CKP signal circuit (CKP sensor connector terminal B and PCM connector terminal 22 to GND)

5. Reconnect the CKP sensor connector.

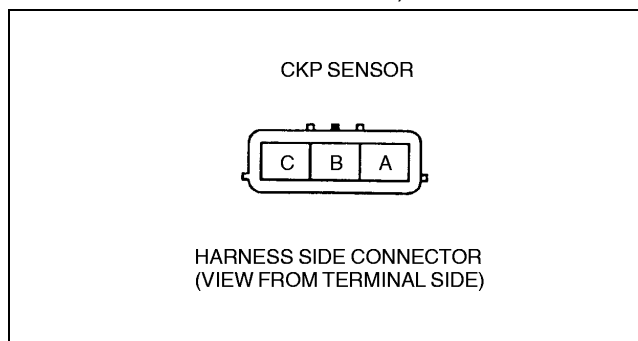

Y3U140WBP



## CONTROL SYSTEM [FS]

### CRANKSHAFT POSITION (CKP) SENSOR REMOVAL/INSTALLATION [FS]

A3U014018230W02

#### Caution

- When foreign material such as an iron chip is on the CKP sensor, it can cause abnormal output from the sensor because of flux turbulence and adversely affect the engine control. Be sure there is no foreign material on the CKP sensor when replacing.

1. Disconnect the CKP sensor connector.
2. Remove the undercover.
3. Remove the CKP sensor installation bolt.
4. Install in the reverse order of removal.

#### Tightening torque

7.9—10.7 N·m  
{80—110 kgf·cm, 69.5—95.4 in·lbf}

5. Reconnect the CKP sensor connector.

#### Caution

- Do not forcefully pull the wiring harness of the CKP sensor, or harness will be damaged.

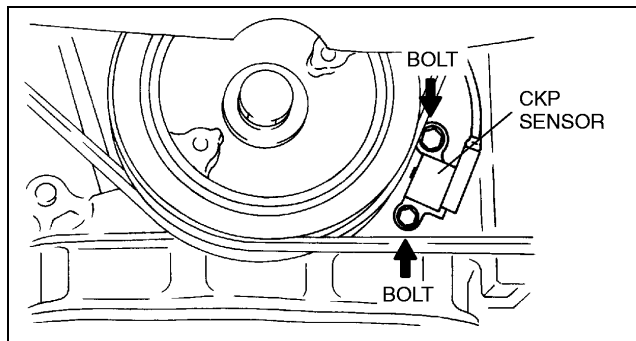

X3U140WDH

### CAMSHAFT POSITION (CMP) SENSOR REMOVAL/INSTALLATION [FS]

A3U014018200W01

#### Caution

- When foreign material such as an iron chip is on the CMP sensor, it can cause abnormal output from the sensor because of flux turbulence and adversely affect the engine control. Be sure there is no foreign material on the CMP sensor when replacing.

1. Disconnect the negative battery cable.
2. Disconnect the CMP sensor connector.
3. Remove the CMP sensor installation bolt.
4. Remove the spacer.
5. Remove the CMP sensor.
6. Make sure that the CMP sensor is free of any metallic shavings or particles.
  - If metallic shavings or particles are found on the sensor, clean them off.
7. Install in the reverse order of removal.

#### Tightening torque

7.9—10.7 N·m  
{80—110 kgf·cm, 69.5—95.4 in·lbf}

## CAMSHAFT POSITION (CMP) SENSOR INSPECTION [FS]

A3U014018200W02

### Resistance Inspection

#### Note

- Perform the following test only when directed.

1. Disconnect the CMP sensor connector.
2. Measure the resistance between the CMP sensor connector terminals A and B using an ohmmeter.
  - If not as specified, replace the CMP sensor.
  - If CMP sensor resistance is okay, but PID value or PCM terminal 85 and 86 voltage are out of specification, carry out the "Circuit Open/Short Inspection".

#### Specification

**0.95—1.25 kilohms**

01-40B

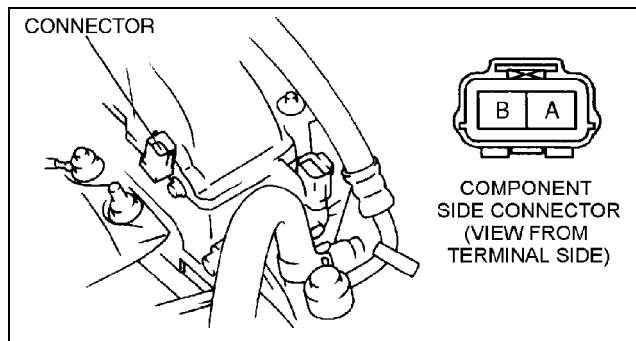

A3U0140W006

### Circuit Open/Short Inspection

1. Remove the PCM. (See 01-40B-7 PCM REMOVAL/INSTALLATION [FS].)
2. Connect the **SST** (104 Pin Breakout Box) to the PCM as shown.
3. Tighten the connector attaching screw.

#### Tightening torque

**7.9—10.7 N·m**

**{80—110 kgf·cm, 69.5—95.4 in·lbf}**

4. Inspect for an open or short circuit in the following wiring harnesses by probing the applicable sensor and **SST** (104 Pin Breakout Box) terminals with ohmmeter leads.
  - If there is an open or short circuit, repair or replace wiring harnesses.
  - If there is no open or short circuit, replace the CMP sensor.

#### Open circuit

- CMP signal circuit (CMP sensor connector terminal A and PCM connector terminal 85)
- CMP signal circuit (CMP sensor connector terminal B and PCM connector terminal 86)

#### Short circuit

- CMP signal circuit (CMP sensor connector terminal A and PCM connector terminal 85 to GND)
- CMP signal circuit (CMP sensor connector terminal B and PCM connector terminal 86 to GND)

5. Reconnect the CMP sensor connector.

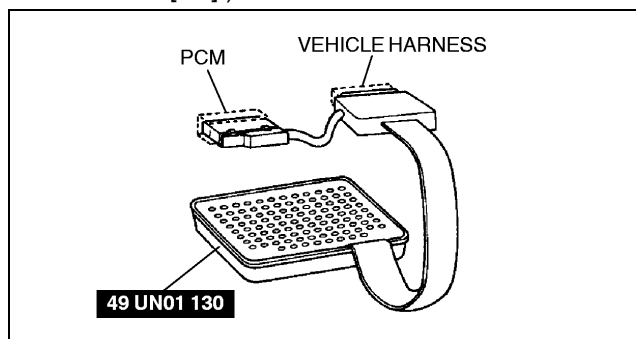

X3U140WE8

## KNOCK SENSOR INSPECTION [FS]

A3U014018921W01

### Note

- Perform the following test only when directed.

### Resistance Inspection

1. Turn the ignition switch to LOCK.
2. Disconnect the knock sensor connector.
3. Measure the resistance between the knock sensor terminals A and B.
  - If not as specified, replace the knock sensor.
  - If the knock sensor is okay, but PCM terminals 57 and 59 voltages are out of specification, perform the "Circuit Open/Short Inspection".

### Specification

**532—588 kilohms (20 °C {68 °F})**

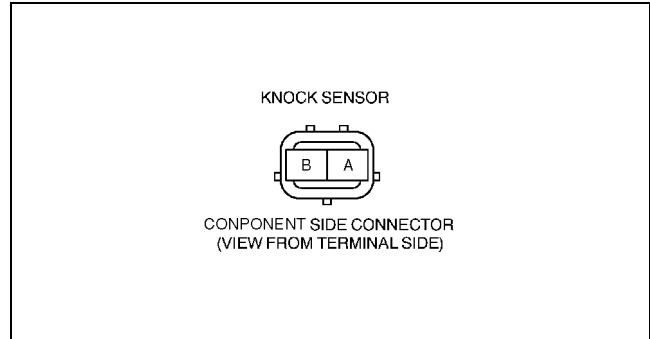

A3U0140W003

### Circuit Open/Short Inspection

1. Disconnect the PCM connector. (See 01-40B-7 PCM REMOVAL/INSTALLATION [FS].)
2. Connect the **SST** (104 Pin Breakout Box) with the PCM disconnected.
3. Tighten the connector attaching bolt.

### Tightening torque

**7.9—10.7 N·m**  
**{80—110 kgf·cm, 69.5—95.4 in·lbf}**

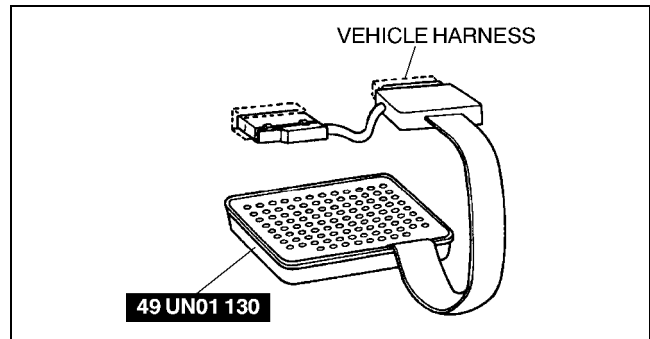

YMU116WAQ

4. Inspect the following wiring harness for open or short (Continuity check).

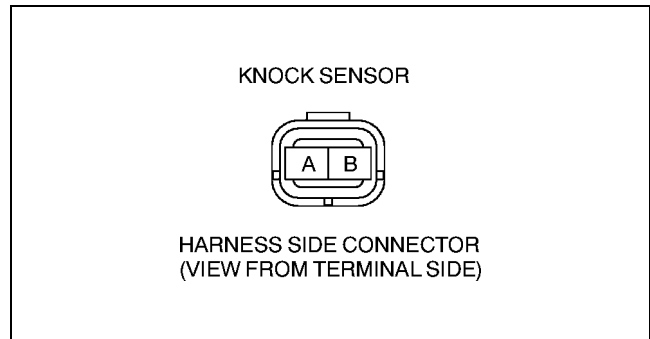

A3U0140W002

### Open circuit

- If there is no continuity, the circuit is open. Repair or replace the harness.
  - Signal circuit (Knock sensor terminal A and PCM connector terminal 57)
  - Signal circuit (Knock sensor terminal B and PCM connector terminal 59)

### Short circuit

- If there is continuity, the circuit is shorted. Repair or replace the harness.
  - Signal circuit (Knock sensor terminal A and PCM connector terminal 57 to GND)
  - Signal circuit (Knock sensor terminal B and PCM connector terminal 59 to GND)

## KNOCK SENSOR REMOVAL/INSTALLATION [FS]

A3U014018921W02

1. Disconnect the knock sensor connector.
2. Remove the knock sensor.
3. Install in the reverse order of removal.

### Tightening torque

**19.6—34.3 N·m {2.00—3.49 kgf·m, 14.5—25.2 ft·lbf}**

01-40B

## HEATED OXYGEN SENSOR (HO2S) INSPECTION [FS]

A3U014018861W01

### HO2S (Front and Rear) Voltage Inspection

#### Note

- Perform the following test only when directed.
1. Warm up the engine and run it at idle.
  2. Disconnect the HO2S (Front or Rear) connector.
  3. Connect a voltmeter test leads to the following HO2S terminals:
    - (+) lead—HO2S terminal A
    - (-) lead—HO2S terminal B
  4. Run the engine at **3,000 rpm** until the voltmeter indicates **approx. 0.5—0.7 V**.
  5. Verify that the voltmeter needle moves when the engine speed increases and decreases suddenly several times.
    - If not as specified, replace the HO2S.
    - If the HO2S is okay, but PID value or PCM terminal 60 (Front), 35 (Rear) voltage are out of specification, carry out the "Circuit Open/Short Inspection".

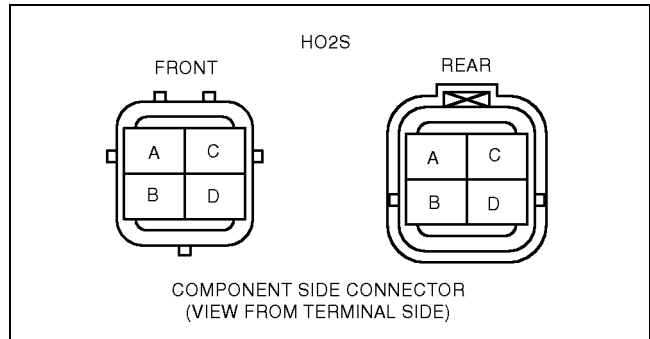

Z3U0140W023

### Specification

Engine condition	Voltage (V)
Acceleration	0.5—1.0
Deceleration	0—0.5

### Circuit Open/Short Inspection

1. Remove the PCM. (See 01-40B-7 PCM REMOVAL/INSTALLATION [FS].)
2. Connect the **SST** (104 Pin Breakout Box) to the PCM as shown.
3. Tighten the connector attaching screw.

### Tightening torque

**7.9—10.7 N·m**  
**{80—110 kgf·cm, 69.5—95.4 in·lbf}**

4. Inspect for an open or short circuit in the following wiring harnesses by probing the applicable sensor and **SST** (104 Pin Breakout Box) terminals with ohmmeter leads.
  - If there is an open or short circuit, repair or replace wiring harnesses.
  - If there is no open or short circuit, replace the HO2S.

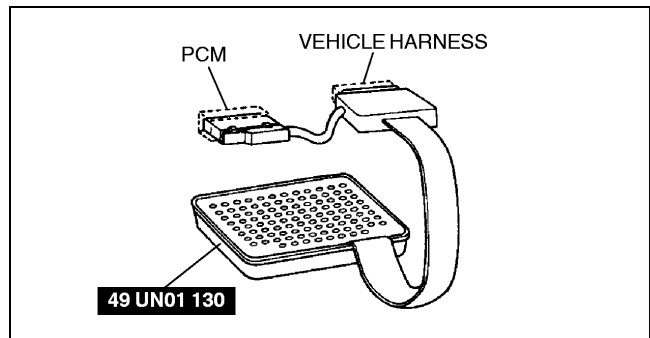

X3U140WE8

## CONTROL SYSTEM [FS]

### Open circuit

- HO2S signal circuit (HO2S connector terminal A and PCM connector terminal 60 (Front), 35 (Rear))
- GND circuit (HO2S connector terminal B and PCM connector terminal 91)

### Short circuit

- HO2S signal circuit (HO2S terminal A and PCM connector terminal 60 (Front), 35 (Rear) to GND)

5. Reconnect the HO2S connector.

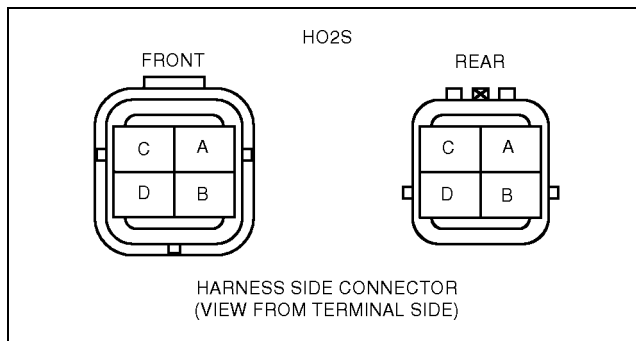

Z3U0140W024

### HO2S Heater (Front and Rear) Resistance Inspection

1. Disconnect the HO2S (Front or Rear) connector.
2. Measure the resistance between HO2S terminals C and D using an ohmmeter.
  - If not as specified, replace the HO2S.
  - If the HO2S heater is okay, but PID value or PCM terminal 94 (Front), 93 (Rear) voltage are out of specification, carry out the "Circuit Open/Short Inspection".

### Specification

**Front: Approx. 5.6 ohms**

**Rear: Approx. 15.7 ohms**

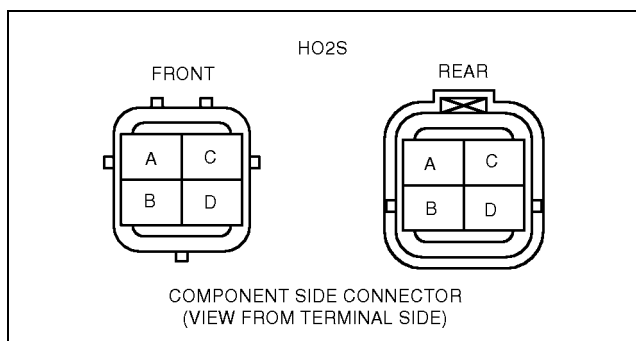

Z3U0140W023

### Circuit Open/Short Inspection

1. Remove the PCM. (See 01-40B-7 PCM REMOVAL/INSTALLATION [FS].)
2. Connect the **SST** (104 Pin Breakout Box) to the PCM as shown.
3. Tighten the connector attaching screw.

### Tightening torque

**7.9—10.7 N·m**

**{80—110 kgf·cm, 69.5—95.4 in·lbf}**

4. Inspect for an open or short circuit in the following wiring harnesses by probing the applicable sensor and **SST** (104 Pin Breakout Box) terminals with ohmmeter leads.
  - If there is an open or short circuit, repair or replace wiring harnesses.
  - If there is no open or short circuit, replace the HO2S.

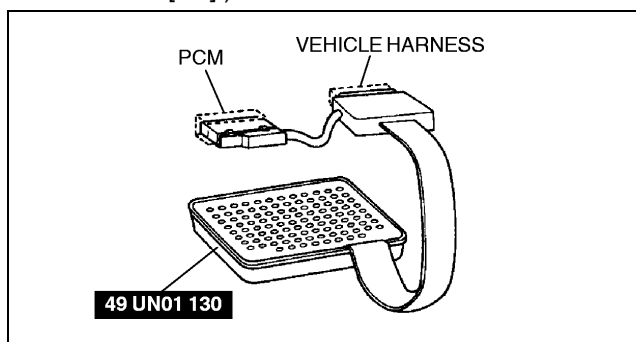

X3U0140WE8

## CONTROL SYSTEM [FS]

### Open circuit

- Control circuit (HO2S connector terminal C and ignition switch (IG1) circuit through common connector)
- GND circuit (HO2S connector terminal D and PCM connector terminal 94 (Front), 93 (Rear))

### Short circuit

- Control circuit (HO2S connector terminal C and ignition switch (IG1) circuit through common connector to GND)
- GND circuit (HO2S connector terminal D and PCM connector terminal 94 (Front), 93 (Rear) to GND)

5. Reconnect the HO2S connector.

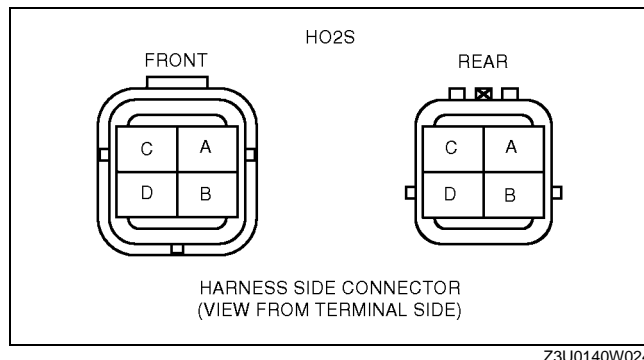

01-40B

## EGR BOOST SENSOR INSPECTION [FS]

A3U014018211W01

### Note

- Perform the following test only when directed.
- The following vacuum values are indicated by relative pressure from barometric pressure.

1. Remove the PCM. (See 01-40B-7 PCM REMOVAL/INSTALLATION [FS].)
2. Connect the **SST** (104 Pin Breakout Box) to the PCM as shown.
3. Tighten the connector bolt.

### Tightening torque

7.9—10.7 N·m  
{80—110 kgf·cm, 69.5—95.4 in·lbf}

### Caution

- Do not apply vacuum outside of the specified limits, or the EGR boost sensor will be damaged.

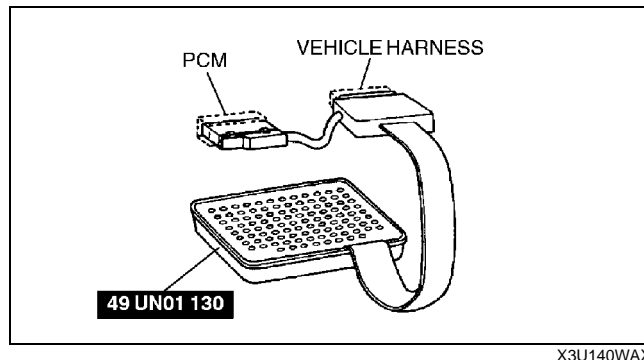

4. Turn the ignition switch to ON.
5. Disconnect the vacuum hose between the EGR boost sensor and intake manifold.

### Note

- The output voltage varies with the measuring condition.

6. Verify that the PCM 34 terminal voltage is within specification.

### Measuring condition:

Input voltage: 4.5—5.5 V  
Ambient temperature: 10—50 °C {50—122 °F}  
Sea level: -20—3,000 m {-656—9,840 ft}

### Specification

Measuring voltage: 2.3—4.7 V

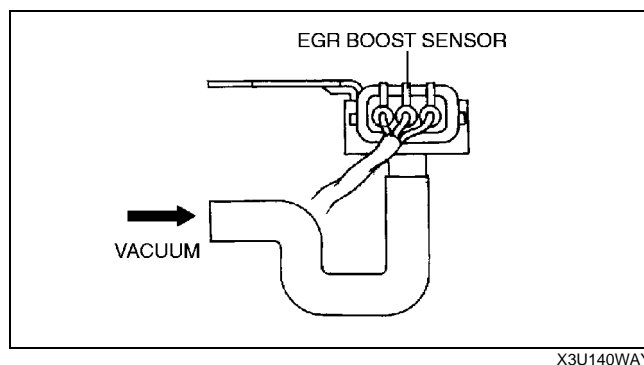

7. Apply vacuum of **-26.6 kPa {-200 mmHg, -7.85 inHg}** to EGR boost sensor and verify that the PCM 34 terminal voltage variation from the specified voltage in Step 6 is within specification.
  - If not as specified, carry out the "Circuit Open/Short Inspection".

### Specification

Monitoring voltage variation: 0.8—1.3 V

## CONTROL SYSTEM [FS]

### Circuit Open/Short Inspection

1. Remove the PCM. (See 01-40B-7 PCM REMOVAL/INSTALLATION [FS].)
2. Connect the **SST** (104 Pin Breakout Box) to the PCM as shown.
3. Tighten the connector attaching screw.

#### Tightening torque

7.9—10.7 N·m

{80—110 kgf·cm, 69.5—95.4 in·lbf}

4. Inspect for an open or short circuit in the following wiring harnesses by probing the applicable sensor and **SST** (104 Pin Breakout Box) terminals with ohmmeter leads.

- If there is an open or short circuit, repair or replace wiring harnesses.
- If there is no open or short circuit, replace the EGR boost sensor.

#### Open circuit

- EGR boost (Barometric pressure) signal circuit (EGR boost sensor connector terminal A and PCM connector terminal 34)
- Constant voltage circuit (EGR boost sensor connector terminal C and PCM connector terminal 90)
- GND circuit (EGR boost sensor connector terminal B and PCM connector terminal 91)

#### Short circuit

- EGR boost (Barometric pressure) signal circuit (EGR boost sensor connector terminal A and PCM connector terminal 34)
- Constant voltage circuit (EGR boost sensor connector terminal C and PCM connector terminal 90)

5. Reconnect the EGR boost sensor connector.

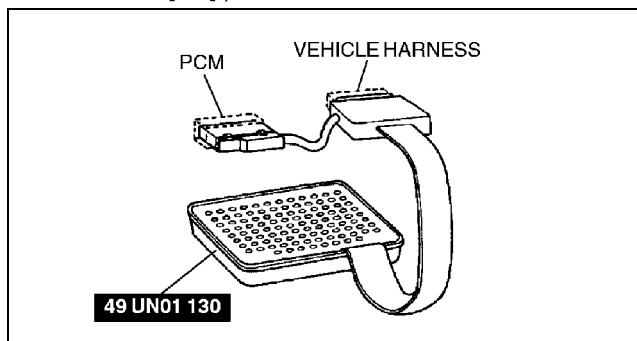

X3U140WAX

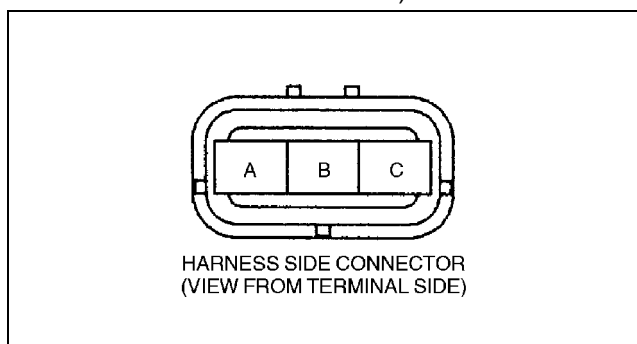

Y3U140WA7

### FUEL TANK PRESSURE SENSOR INSPECTION [FS]

A3U014018212W01

#### Note

- Perform the following test only when directed.
- The following vacuum values are indicated by relative pressure from barometric pressure.

1. Remove the PCM. (See 01-40B-7 PCM REMOVAL/INSTALLATION [FS].)
2. Connect the **SST** (104 Pin Breakout Box) to the PCM as shown.
3. Tighten the connector bolt.

#### Tightening torque

7.9—10.7 N·m

{80—110 kgf·cm, 69.5—95.4 in·lbf}

#### Caution

- Do not apply vacuum outside of the specified limits, or the fuel tank pressure sensor will be damaged.

4. Turn the ignition switch to ON.

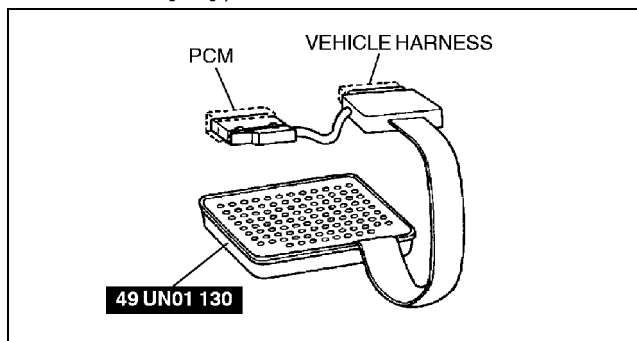

X3U140WB3

## CONTROL SYSTEM [FS]

- Apply pressure then vacuum to the fuel tank pressure sensor according to the following procedure.

**Note**

- The output voltage varies with the measuring condition.

- Decrease the applied pressure from **+6.66 kPa {+50 mmHg, +1.97 inHg}** to **-6.66 kPa {-50 mmHg, -1.97 inHg}** and verify that the PCM terminal 62 voltage decreases accordingly as specified.

- If not as specified, replace the fuel tank pressure sensor.
- If fuel tank pressure sensor is okay, but PCM terminal 62 voltage is out of specification, carry out the "Circuit Open/Short Inspection".

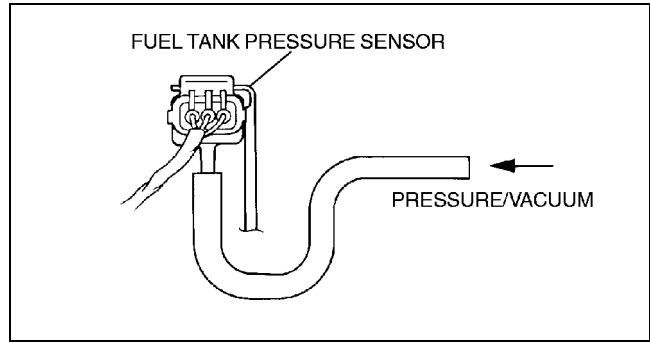

X3U140WB4

01-40B

**Specification**

Applied pressure	Output voltage (V)*
-6.66 kPa {-50 mmHg, -1.97 inHg}	0.45—0.55
0 kPa {0 mmHg, 0 inHg}	2.25—2.75
+6.66 kPa {+50 mmHg, +1.97 inHg}	4.05—4.95

\* : Measuring condition is as follows

**Input voltage: 5.0 V**

**Barometric pressure: 101.3 kPa {760 mmHg, 29.9 inHg} (Absolute pressure)**

**Barometric temperature: 30—100 °C {0—182 °F}**

**Circuit Open/Short Inspection**

- Remove the PCM. (See 01-40B-7 PCM REMOVAL/INSTALLATION [FS].)
- Connect the **SST** (104 Pin Breakout Box) to the PCM as shown.
- Tighten the connector attaching screw.

**Tightening torque**

**7.9—10.7 N·m**

**{80—110 kgf·cm, 69.5—95.4 in·lbf}**

- Inspect for an open or short circuit in the following wiring harnesses by probing the applicable sensor and **SST** (104 Pin Breakout Box) terminals with ohmmeter leads.

- If there is an open or short circuit, repair or replace wiring harnesses.
- If there is no open or short circuit, replace the fuel tank pressure sensor.

**Open circuit**

- Fuel tank pressure signal circuit (Fuel tank pressure sensor connector terminal B and PCM connector terminal 62)
- Constant voltage circuit (Fuel tank pressure sensor connector terminal C and PCM connector terminal 90)
- GND circuit (Fuel tank pressure sensor connector terminal A and PCM connector terminal 91)

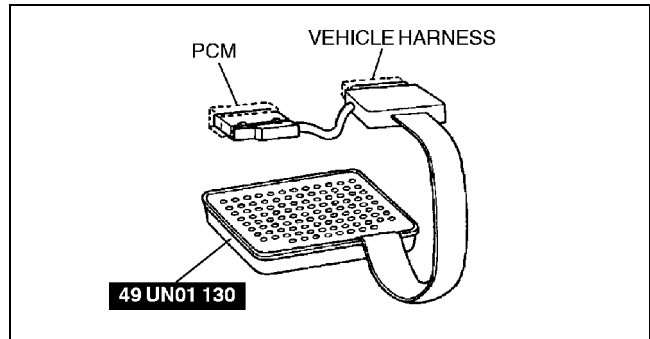

X3U140WB3



## CONTROL SYSTEM [FS]

### Short circuit

- Fuel tank pressure signal circuit (Fuel tank pressure sensor connector terminal B and PCM connector terminal 62)
  - Constant voltage circuit (Fuel tank pressure sensor connector terminal C and PCM connector terminal 90)
5. Reconnect the fuel tank pressure sensor connector.

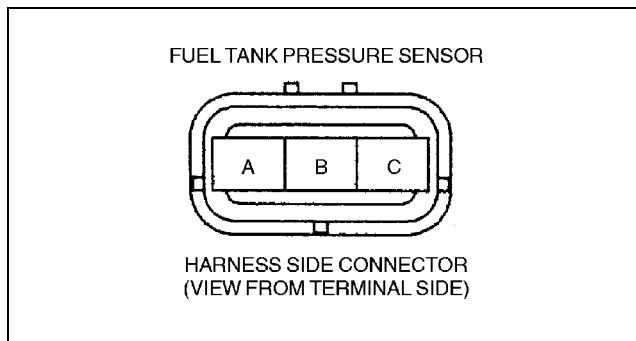

X3U140WB5

### CLUTCH SWITCH INSPECTION [FS]

A3U014018660W01

#### Note

- Perform the following test only when directed.
1. Verify that the clutch switch is installed properly.
  2. Disconnect the negative battery cable.
  3. Remove the clutch switch. (See 05-10-5 CLUTCH PEDAL REMOVAL/INSTALLATION.)
  4. Inspect the continuity between the clutch switch terminals using an ohmmeter.
    - If not as specified, replace the clutch switch.
    - If the clutch switch is okay, but PID value or PCM terminal 6 voltage is out of specification, carry out the "Circuit Open/Short Inspection".

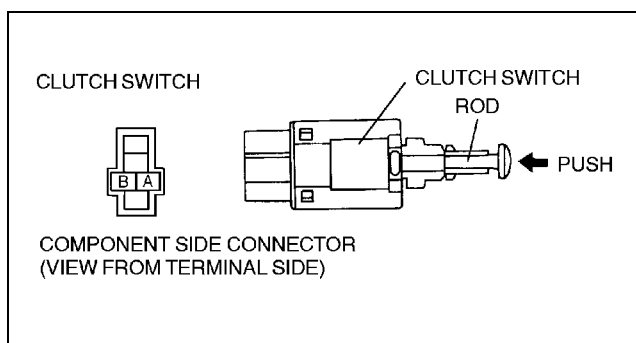

Z3U0140W029

○—○ : Continuity

Condition	Terminal	
	A	B
The rod is pushed		
Except above	○—○	○—○

Z3U0140W030

### Circuit Open/Short Inspection

1. Remove the PCM. (See 01-40B-7 PCM REMOVAL/INSTALLATION [FS].)
2. Connect the **SST** (104 Pin Breakout Box) to the PCM as shown.
3. Tighten the connector attaching screw.

#### Tightening torque

**7.9—10.7 N·m**

**{80—110 kgf·cm, 69.5—95.4 in·lbf}**

4. Inspect for an open or short circuit in the following wiring harnesses by probing the applicable sensor and **SST** (104 Pin Breakout Box) terminals with ohmmeter leads.
  - If there is an open or short circuit, repair or replace wiring harnesses.
  - If there is no open or short circuit, replace the clutch switch.

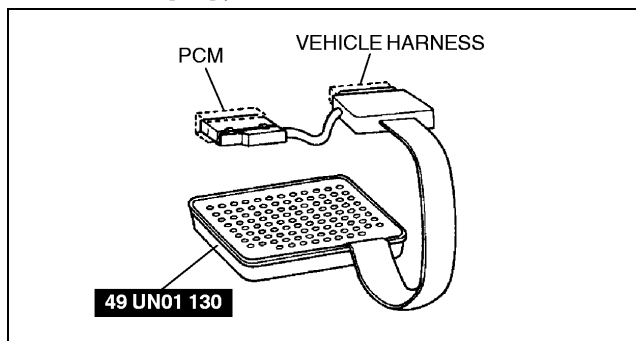

X3U140WE8

**Open circuit**

- Signal circuit (Clutch switch connector terminal B and PCM connector terminal 6 through common connector)
- GND circuit (Clutch switch connector terminal A and GND)

**Short circuit**

- Signal circuit (Clutch switch connector terminal B and PCM connector terminal 6 through common connector to GND)

5. Install the clutch switch.

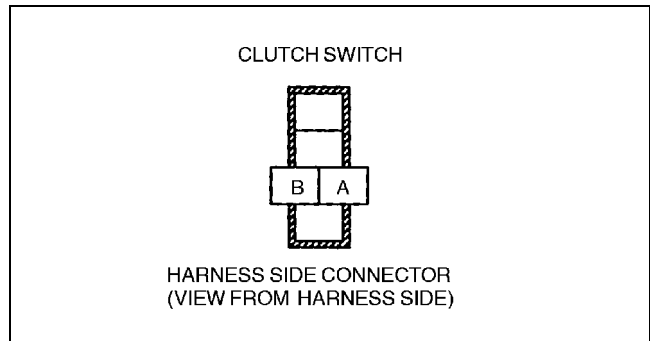

Z3U0140W031

A3U014017640W01

**NEUTRAL SWITCH INSPECTION [FS]**

**Note**

- Perform the following test only when directed.

1. Disconnect the negative battery cable.
2. Remove the neutral switch.
3. Inspect for continuity between the neutral switch terminals using an ohmmeter.
  - If not as specified, replace the neutral switch.
  - If the neutral switch is okay, but PID value or PCM terminal 64 voltage is out of specification, carry out the "Circuit Open/Short Inspection".

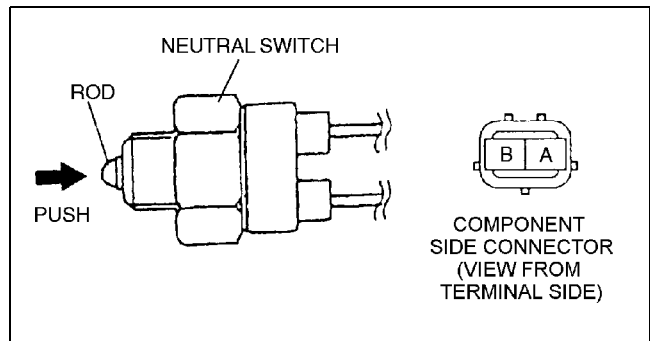

A3U0140W004

○—○ : Continuity

Condition	Terminal	
	A	B
The rod is pushed	○—○	○—○
Except above		

X3U140WE3

**Circuit Open/Short Inspection**

1. Remove the PCM. (See 01-40B-7 PCM REMOVAL/INSTALLATION [FS].)
2. Connect the **SST** (104 Pin Breakout Box) to the PCM as shown.
3. Tighten the connector attaching screw.

**Tightening torque**

**7.9—10.7 N·m**  
**{80—110 kgf·cm, 69.5—95.4 in·lbf}**

4. Inspect for an open or short circuit in the following wiring harnesses by probing the applicable sensor and **SST** (104 Pin Breakout Box) terminals with ohmmeter leads.
  - If there is an open or short circuit, repair or replace wiring harnesses.
  - If there is no open or short circuit, replace the neutral switch.

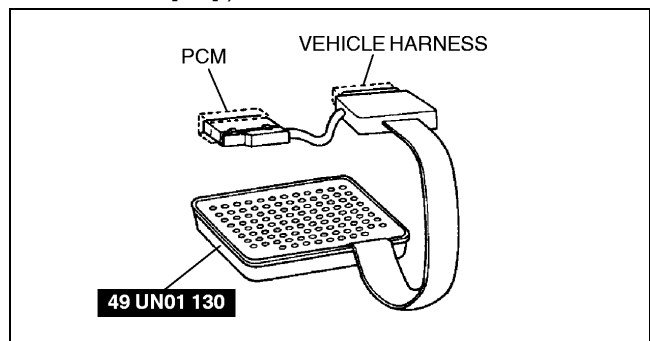

X3U140WE8

**Open circuit**

- Signal circuit (Neutral switch connector terminal A and PCM connector terminal 64 through common connector)
- GND circuit (Neutral switch connector terminal B and GND through common connector)

**Short circuit**

- Signal circuit (Neutral switch connector terminal A and PCM terminal 64 through common connector to GND)

# CONTROL SYSTEM [FS]

5. Install the neutral switch.

## POWER STEERING PRESSURE (PSP) SWITCH INSPECTION [FS]

A3U014032230W01

### Continuity Inspection

#### Note

- Perform the following test only when directed.

1. Inspect as follows if the power steering is inoperative. (See 06–12–3 POWER STEERING FLUID INSPECTION.)
  - Power steering fluid level
  - Power steering fluid leakage
  - Power steering fluid pressure
2. Disconnect the PSP switch connector.
3. Start the engine.
4. Inspect for continuity between the PSP switch terminal and GND using an ohmmeter.
  - If not as specified, replace the PSP switch.
  - If the PSP switch is okay, but PID value or PCM terminal 31 voltage are out of specification, carry out the "Circuit Open/Short Inspection".

○—○ : Continuity

Condition	Terminal	GND
Steering wheel is in straight ahead position		
Steering wheel is fully turned	○—○	○—○

X3U140WE4

### Circuit Open/Short Inspection

1. Remove the PCM. (See 01–40B–7 PCM REMOVAL/INSTALLATION [FS].)
2. Connect the **SST** (104 Pin Breakout Box) to the PCM as shown.
3. Tighten the connector attaching screw.

#### Tightening torque

7.9—10.7 N·m

{80—110 kgf·cm, 69.5—95.4 in·lbf}

4. Inspect for an open or short circuit in the following wiring harnesses by probing the applicable sensor and **SST** (104 Pin Breakout Box) terminals with ohmmeter leads.
  - If there is an open or short circuit, repair or replace wiring harnesses.
  - If there is no open or short circuit, replace the PSP switch.

#### Open circuit

- PSP signal circuit (PSP switch connector terminal and PCM connector terminal 31 through common connector)
- GND circuit (PSP switch body and GND)

#### Short circuit

- PSP signal circuit (PSP switch connector terminal and PCM connector terminal 31 through common connector to GND)

5. Reconnect the PSP switch connector.

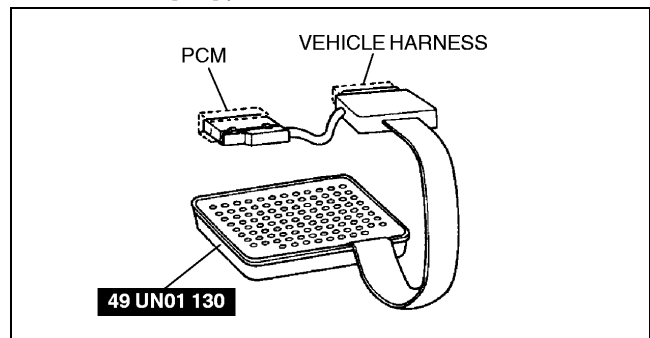

X3U140WE8

# TECHNICAL DATA

## 01-50 TECHNICAL DATA

ENGINE TECHNICAL DATA . . . . . 01-50-1

### ENGINE TECHNICAL DATA

A3U015001001W01

01-50

Item		Engine			
		ZM		FS	
		MTX	ATX	MTX	ATX
<b>MECHANICAL</b>					
Drive belt deflection	Generator	New	5.5—7.0 {0.22—0.27}	6.5—7.5 {0.26—0.29}	
		Used	6.0—7.5 {0.24—0.29}	7.0—9.0 {0.28—0.35}	
		Limit	8.0 {0.31}	10.0 {0.39}	
	P/S, P/S+A/C	New	7.0—8.0 {0.28—0.31}	7.5—9.0 {0.30—0.35}	
		Used	9.0—10.0 {0.36—0.39}	8.0—9.5 {0.32—0.37}	
		Limit	11.5 {0.45}	11.0 {0.43}	
Drive belt tension	Generator	New	500—740 {50—76, 110—160}	690—830 {70—85, 160—180}	
		Used	500—700 {50—72, 110—150}	500—680 {50—70, 110—150}	
		Limit	340 {35, 77}	390 {40, 88}	
	P/S, P/S+A/C	New	590—680 {60—70, 140—150}	590—780 {60—80, 140—170}	
		Used	430—490 {43—50, 95—110}	500—680 {50—70, 110—150}	
		Limit	250 {25, 55}	390 {40, 88}	
Valve clearance [Engine cold]	IN	0.25—0.31 {0.010—0.012} (0.28±0.03 {0.011±0.001})	0.225—0.295 {0.0089—0.0116} (0.26±0.035 {0.010±0.0014})		
	EX	0.25—0.31 {0.010—0.012} (0.28±0.03 {0.011±0.001})	0.225—0.295 {0.0089—0.0116} (0.26±0.035 {0.010±0.001})		
Compression pressure (kPa {kgf/cm <sup>2</sup> , psi} [rpm])	Standard	1,373 {14.0, 199} [300]	1,177 {12.0, 171} [300]		
	Minimum	981 {10.0, 142} [300]	824 {8.4, 119} [300]		
	Maximum difference between cylinders	196 {2.0, 28}			
Tensioner spring free length (mm {in})		61.8 {2.43}	36.6 {1.44}		
Pushing distance of the camshaft oil seal (mm {in})		0—0.4 {0—0.01} (from the edge of the cylinder head)	0.3—0.7 {0.012—0.027} (from the edge of the cylinder head)		
Pushing distance of the front oil seal (mm {in})		0.5—1.0 {0.020—0.039} (from the edge of the oil pump body)	0—0.5 {0—0.01} (from the edge of the oil pump body)		
Pushing distance of the rear oil seal (mm {in})		0—0.5 {0—0.01} (from the edge of the rear cover)			
Cylinder head bolt length (mm {in})	Standard	99.2—99.8 {3.91—3.92}	104.2—104.8 {4.103—4.125}		
	Maximum	100.5 {3.956}	105.5 {4.153}		
Idle speed (rpm)		650—750			
Ignition timing (BTDC/rpm)		6—18°/650—750			
Idle-up speed <sup>*1</sup> (rpm)	E/L ON <sup>*2</sup>	650—750			
	A/C ON <sup>*3</sup>	700—800			
	P/S ON <sup>*4</sup>	700—800			
Idle mixture	HC concentration	within the regulation			
	CO concentration	within the regulation			

## TECHNICAL DATA

Item				Engine				
				ZM		FS		
				MTX	ATX	MTX	ATX	
<b>LUBRICATION SYSTEM</b>								
Oil pressure		(kPa {kgf/cm <sup>2</sup> , psi})	300—390 {3.0—4.0, 43—56} [at 3,000 rpm]		400—490 {4.0—5.0, 57—71} [at 3,000 rpm]			
Oil capacity (approximate quantity)	Total (dry engine)		(L {US qt, Imp qt})	3.4 {3.6, 3.0}		3.7 {3.9, 3.3}		
	Oil replacement		(L {US qt, Imp qt})	3.0 {3.2, 2.6}		3.3 {3.5, 2.9}		
	Oil and oil filter replacement		(L {US qt, Imp qt})	3.2 {3.4, 2.8}		3.5 {3.7, 3.1}		
Engine oil				API Service SG (Energy Conserving <b>II</b> ), SH (Energy Conserving <b>II</b> ), SJ or ILSAC (GF- <b>I</b> , GF- <b>II</b> )				
Viscosity	Above -25 °C {-13 °F}			SAE 10W-30				
	Below 0 °C {32 °F}			SAE 5W-30				
Oil pump	Inner rotor tooth tip to outer rotor clearance	(mm {in})	Standard	0.02—0.18 {0.0008—0.0070}		0.130—0.206 {0.00512—0.0081}		
			Maximum	0.22 {0.087}		0.30 {0.012}		
	Outer rotor to body clearance	(mm {in})	Standard	0.09—0.18 {0.0036—0.0070}		0.113—0.186 {0.00445—0.00732}		
			Maximum	0.22 {0.087}				
	Side clearance	(mm {in})	Standard	0.03—0.11 {0.0012—0.0043}		0.035—0.095 {0.0014—0.0037}		
			Maximum	0.14 {0.005}				
Pressure spring free length			(mm {in})	45.94 {1.809}		—		
Pressing force at pressure spring height H			(N {kgf, lbf})	H: 33.50mm {1.319 in}	—		97.7—107.4 {9.96—10.96, 21.92—24.11}	
Front oil seal	Pushing distance of the front oil seal (from the edge of the oil pump body)		(mm {in})	0.5—1.0 {0.020—0.039}		0—0.5 {0—0.01}		
<b>COOLING SYSTEM</b>								
Coolant capacity (approximate quantity)		(L {US qt, Imp qt})	6.0 {6.4, 5.3}		7.5 {8.0, 6.6}			
Radiator cap valve opening pressure		(kPa {kgf/cm <sup>2</sup> , psi})	94—122 {0.95—1.25, 13.6—17.7}					
Thermostat	Initial-opening temperature		(°C {°F})	83.5—88 {183—190}		80—84 {176—183}		
	Full-opening temperature		(°C {°F})	100 {212}		95 {203}		
	Full-open lift		(mm {in})	8.5 {0.33} min.				
Cooling fan motor current			(A)	2.4—4.4	5.2—7.2	2.4—4.4	5.2—7.2	
<b>FUEL SYSTEM</b>								
Fuel line hold pressure		(kPa {kgf/cm <sup>2</sup> , psi})	More than 150 {1.5, 22.0}					
Fuel pump maximum pressure		(kPa {kgf/cm <sup>2</sup> , psi})	450—630 {4.5—6.5, 64—92}					
Fuel injector	Leakage		Less than 1 drop/2 minutes					
	Volume	(ml {cc, fl oz}/15 sec.)	38.1—40.4 {38.1—40.4, 1.29—1.36}		68—75 {68—75, 2.30—2.53}			
			Approx. 13.8		14.2—14.8			
<b>CHARGING SYSTEM</b>								
Battery	Electrolyte gravity		1.27—1.29 [20 °C {68 °F}]					
	Back-up current*5		(mA)	Max. 20				
	Test load chart (A)	Battery type	50D20L	150				
			75D23L	—		195		
	Slow charge (A)	Battery type (5-hour rate)	50D20L (40)	4.0—5.0				
			75D23L (52)	—		5.5—6.5		
Quick charge (A/30 min)	Battery type (5-hour rate)	50D20L (40)	25					
		75D23L (52)	—		35			

## TECHNICAL DATA

					Engine			
					ZM		FS	
					MTX	ATX	MTX	ATX
Generator	Rotor resistance (Between slip rings)			(ohms)	2.5—2.9			
	Brush length	Standard		(mm {in})	18.5 {0.73}			
		Minimum		(mm {in})	5.0 {0.20}			
	Brush spring force	Standard		(N {kgf, lbf})	4.8—6.0 {0.48—0.62, 1.06—1.36}			
		Minimum		(N {kgf, lbf})	2.2 {0.22, 0.48}			
	Standard voltage (V)	Ignition switch ON	Terminal	B	B+			
				P	Approx. 1			
		D	Approx. 0					
	Idle [20 °C {68 °F}]	Terminal	B	13—15				
			P	Approx. 3—8				
D			*					
Generated current (Reference) (A)	Engine speed (rpm)	1,000	Terminal B current	0—60* <sup>6</sup>		0—59* <sup>6</sup>		
		2,000	Terminal B current	0—68* <sup>6</sup>		0—77* <sup>6</sup>		
<b>IGNITION SYSTEM</b>								
Ignition coil	Resistance [20°C{68°F}] (kilohms)	Secondary coil		8.0—12.0		7.2—10.8		
		Insulation resistance of case		10000				
High-tension lead	Resistance (kilohms)	No.1 lead		3.3—7.8		5.6—12.1		
		No.3 lead		2.9—6.9		1.9—4.0		
Spark plug	Type	NGK		ZFR5F-11* <sup>7</sup> , ZFR6F-11* <sup>8</sup>		BKR5E-11* <sup>7</sup> , BKR6E-11* <sup>8</sup>		
		DENSO		KJ16CR11* <sup>7</sup> , KJ20CR11* <sup>8</sup>		K16PR-U11* <sup>7</sup> , K20PR-U11* <sup>8</sup>		
		CHAMPION		—		RC10YC4* <sup>7</sup> , RC8YC4* <sup>8</sup>		
		MAZDA		—		BP13 18 110* <sup>7</sup> , BP14 18 110* <sup>8</sup>		
	Plug gap			(mm {in})	1.0—1.1 {0.040—0.043}			
	Resistance (kilohms)	NGK		3.0—7.5				
		DENSO						
		CHAMPION		—		5—15		
MAZDA								
Tightening torque			(N·m {kgf·m, ft·lbf})	15—22 {1.5—2.3, 11—16}				
<b>STARTING SYSTEM</b>								
Starter	Commutator diameter	Standard		(mm {in})	29.4 {1.16}			
		Minimum		(mm {in})	28.8 {1.14}			
	Brush length	Standard		(mm {in})	12.3 {0.48}			
		Minimum		(mm {in})	7.0 {0.28}			
	Brush spring force	Standard		(N {kgf, lbf})	180—243 {18.3—24.8, 40.3—54.5}			
		Minimum		(N {kgf, lbf})	57.7 {5.88, 12.9}			
	Pinion gap			(mm {in})	3.0 {0.12}			
	No load test	Voltage		(V)	11			
Current		(A)	Below 90					

01-50

\* : Turn the following electrical loads on and verify that the voltage reading increases.

- Headlights
- Blower motor
- Rear window defroster

\*1 : Excludes temporary idle speed drop just after the loads (E/L, A/C, P/S) are turned on.

\*2 : Headlight, fan switch (3rd or higher) and cooling fan are turned on.

\*3 : A/C switch and fan switch are turned on.

## TECHNICAL DATA

---

- \*4 : Steering wheel fully turned.
- \*5 : Back-up current is the constant flow of current present (for the audio unit, clock, PCM, etc.) when the ignition switch is at off and with the ignition key removed.
- \*6 : Must not be 0 A
- \*7 : Standard plug
- \*8 : Cold type plug

# SERVICE TOOLS







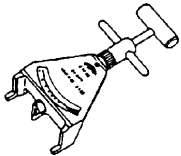
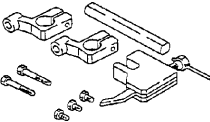

## 01-60 SERVICE TOOLS

ENGINE SST ..... 01-60-1

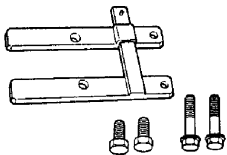
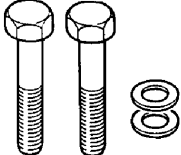
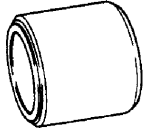
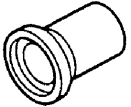
### ENGINE SST

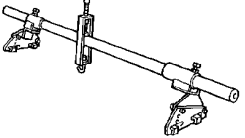
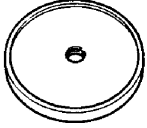

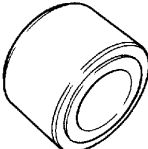
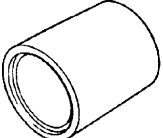
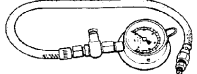
A3U016001001W01

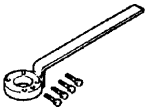
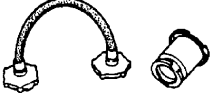
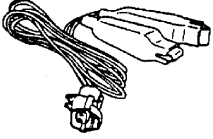
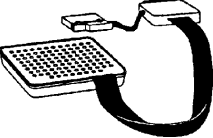
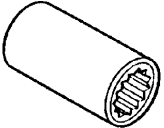
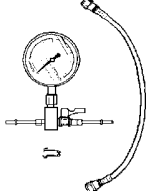
01-60

<p>49 9200 020A</p> <p>V-ribbed belt tension gauge</p> 	<p>49 T012 0A0A</p> <p>Tappet holder set</p> 	<p>49 S120 710</p> <p>Coupling flange holder &lt;FS&gt;</p> 
<p>49 E011 1A1</p> <p>Holder set &lt;FS&gt;</p> 	<p>49 G011 103</p> <p>Bolts &lt;FS&gt;</p> 	<p>49 B014 001</p> <p>Oil seal installer</p> 
<p>49 H010 401</p> <p>Oil seal installer &lt;FS&gt;</p> 	<p>49 G033 107A</p> <p>Dust cover installer &lt;FS&gt;</p> 	<p>49 E017 5A0</p> <p>Engine support set</p> 
<p>49 W033 105</p> <p>Oil seal installer &lt;ZM&gt;</p> 	<p>49 G030 797</p> <p>Handle (Part of 49 G030 795) &lt;ZM&gt;</p> 	<p>49 B010 001</p> <p>Oil seal installer &lt;ZM&gt;</p> 
<p>49 T028 302</p> <p>Dust boot installer &lt;ZM&gt;</p> 	<p>49 0187 280A</p> <p>Oil pressure gauge</p> 	<p>49 G014 001</p> <p>Oil filter wrench</p> 
<p>49 D011 102</p> <p>Crankshaft lock tool &lt;ZM&gt;</p> 	<p>49 9200 145 (ATX) 49 D015 0A0 (MTX)</p> <p>Radiator cap tester adapter set</p> 	<p>49 L018 901</p> <p>Injector checker</p> 
<p>49 UN01 130</p> <p>104 Pin breakout box</p> 	<p>49 D015 004</p> <p>Box wrench</p> 	<p>49 N013 1A0B</p> <p>Fuel pressure gauge set</p> 

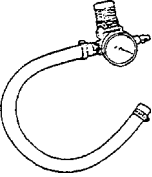
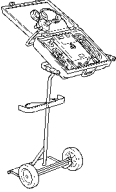
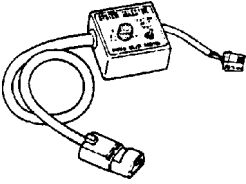

# SERVICE TOOLS

<p>49 U014 001</p> <p>Air pressure tester</p> 	<p>MZ254AT3641</p> <p>Evaporative emission system tester</p> 	<p>49 B019 9A0</p> <p>System selector</p> 
<p>418FS475</p> <p>WDS</p> 		

# SUSPENSION

**02**  
SECTION

<b>GENERAL PROCEDURES . . . . .</b>	<b>02-10</b>	<b>REAR SUSPENSION . . . . .</b>	<b>02-14</b>
<b>WHEEL ALIGNMENT . . . . .</b>	<b>02-11</b>	<b>TECHNICAL DATA . . . . .</b>	<b>02-50</b>
<b>FRONT SUSPENSION . . . . .</b>	<b>02-13</b>	<b>SERVICE TOOLS . . . . .</b>	<b>02-60</b>

02-10

## 02-10 GENERAL PROCEDURES

<b>PRECAUTION (SUSPENSION) . . . . .</b>	<b>02-10-1</b>	<b>Power Steering Components</b>	
Wheels and Tires		Removal/installation . . . . .	<b>02-10-1</b>
Removal/installation . . . . .	<b>02-10-1</b>		
Suspension Links			
Removal/installation . . . . .	<b>02-10-1</b>		

### PRECAUTION (SUSPENSION)

A3U021001013W01

#### Wheels and Tires Removal/installation

1. The removal and installation procedures for the wheels and tires are not mentioned in this section. When a wheel is removed, retighten it to **89—117 N·m {9—12 kgf·m, 66—86 ft·lbf}**.

#### Suspension Links Removal/installation

1. Tighten any part of the suspension that uses rubber bushings only after the vehicle has been lowered and unloaded.

#### Note

- Unloaded ... Fuel tank is full. Engine coolant and engine oil are at specified levels. Spare tire, jack and tools are in designated positions.

#### Power Steering Components Removal/installation

1. If any power steering fluid line has been disconnected anytime during the procedure, add ATF M-III or equivalent (e.g. Dexron® III), bleed the fluid line, and inspect for leakage after the procedure has been completed.

# 02-11 WHEEL ALIGNMENT

**WHEEL ALIGNMENT**

**PRE-INSPECTION** ..... 02-11-1  
**FRONT WHEEL ALIGNMENT** ..... 02-11-1  
 Specification (Unloaded)\*1 ..... 02-11-1  
 Maximum Steering Angle Adjustment . 02-11-1

Camber and Caster Adjustment .....02-11-2  
 Total Toe-in Adjustment .....02-11-2  
**REAR WHEEL ALIGNMENT** .....02-11-3  
 Specification (Unloaded)\*1 .....02-11-3  
 Total Toe-in Adjustment .....02-11-3

**WHEEL ALIGNMENT PRE-INSPECTION**

A3U021101013W01

1. Inspect the tire inflation, and adjust to the recommended pressure as necessary.
2. Inspect the front wheel for bearing play and correct it if necessary. (See 03-11-1 Wheel Bearing Play Inspection.)
3. Inspect the wheel and tire runouts. (See 02-50-1 SUSPENSION TECHNICAL DATA.)
4. Inspect the ball joints and steering linkage for excessive looseness.
5. Shake the vehicle to inspect the operation of the shock absorbers.

**Note**

- The vehicle must be on level ground and unloaded.
- Unloaded ... Fuel tank is full. Engine coolant and engine oil are at specified levels. Spare tire, jack and tools are in designated positions.

6. Measure the height from the center of the wheel to the fender brim. The difference between the left and right measurement must not exceed **10 mm {0.39 in}**.

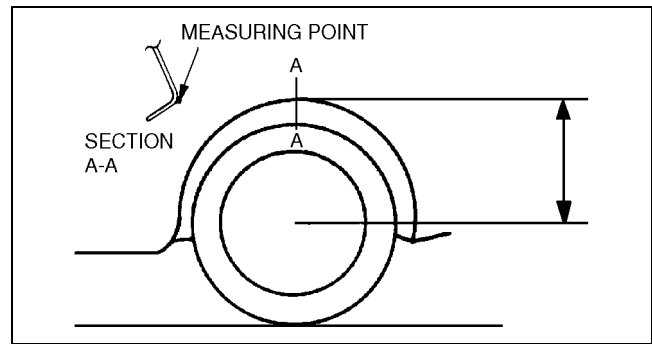

Z3U0211W001

**FRONT WHEEL ALIGNMENT**

**Specification (Unloaded)\*1**

A3U021101015W01

Item		Fuel gauge indication				
		Empty	1/4	1/2	3/4	Full
Total toe-in	(mm {in})	2±4 {0.08±0.16}				
	(degree)	0°12'±24'				
Maximum steering angle	Inner	37°±3°				
	Outer	33°±3°				
Caster angle*2		1°46'±1°	1°49'±1°	1°51'±1°	1°53'±1°	1°56'±1°
Camber angle*2		-0°48'±1°			-0°49'±1°	
Kingpin angle (reference value)		12°34'		12°35'		12°36'

\*1 : Engine coolant and engine oil are at specified levels. Spare tire, jack and tools are in designated positions.  
 \*2 : Difference between left and right must not exceed **1°30'**.

**Maximum Steering Angle Adjustment**

1. Loosen the tie-rod end locknuts.
2. Remove the steering gear boot clamp.

## WHEEL ALIGNMENT

- Turn the left and right tie rods to equalize the length L.

**Maximum left/right difference**  
**3 mm {0.12 in}**

**Note**

- Turn the tie rods equally.

- Turn the tie rod to provide the correct maximum steering angle.
- Tighten the tie-rod end locknuts.

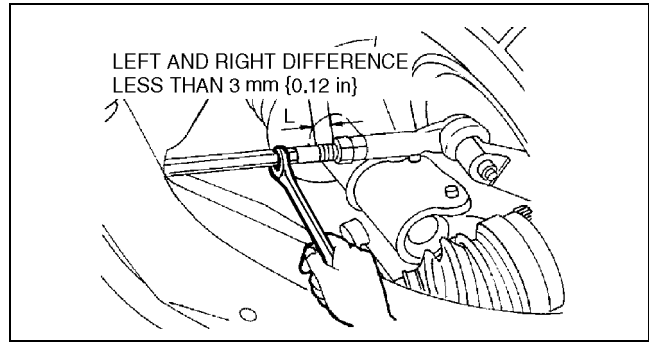

Z3U0211W002

**Tightening torque**  
**68.7—98.0 N·m {7.0—10.0 kgf·m, 50.7—72.3 ft·lbf}**

- Verify that the boot is not twisted, and install the boot clamp.
- Adjust the toe-in after adjusting the steering angle.

### Camber and Caster Adjustment

- Jack up the front of the vehicle and support it on safety stands.
- Remove the mounting block nuts.
- Push the mounting block downward, and turn it to the desired position.

Direction indicator position	Adjustment valve from original position	
	Camber angle	Caster angle
A	+30'	0°
B	+30'	+30'
C	0°	+30'

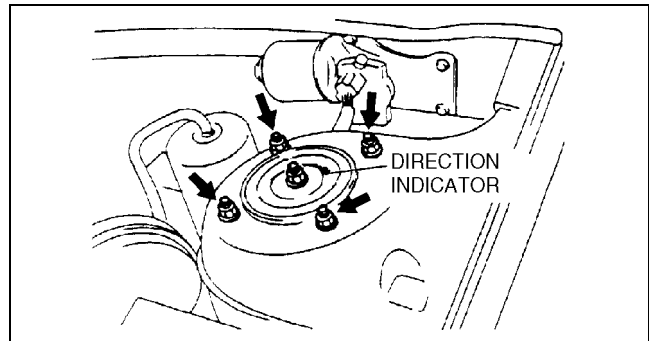

Z3U0211W003

- Install and tighten the mounting nuts to the specified torque.

**Tightening torque**  
**47—62 N·m {4.7—6.4 kgf·m, 34—46 ft·lbf}**

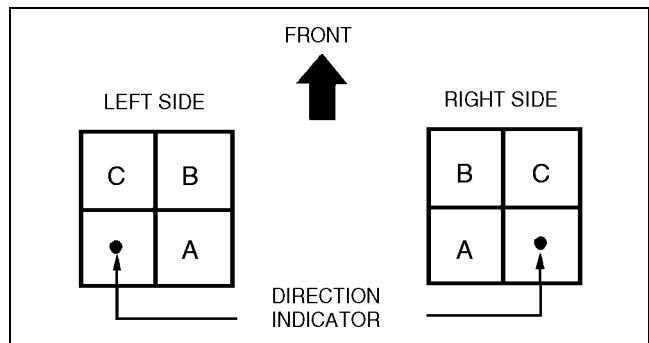

Z3U0211W004

### Total Toe-in Adjustment

- Center the steering wheel and confirm that the vehicle wheels/tires are pointing straight.
- Remove the steering gear boot clamp.
- Loosen the left and right tie rod locknuts and turn the tie rods equally. Both tie rods are right threaded, so turning the right tie rod toward the front of the vehicle and the left toward the rear increases toe-in.

**Note**

- Turning both tie rods one complete turn changes toe-in by **about 6 mm {0.24 in} (0°36')**.

- Tighten the tie rod locknuts to the specified torque.

**Tightening torque**  
**68.7—98.0 N·m {7.0—10.0 kgf·m, 50.7—72.3 ft·lbf}**

- Verify that the boot is not twisted, and install the boot clamp.

# WHEEL ALIGNMENT

## REAR WHEEL ALIGNMENT

A3U021101016W01

### Specification (Unloaded)\*1

Fuel gauge indication		Empty	1/4	1/2	3/4	Full
Total toe-in	(mm {in})	2±4 {0.08±0.16}				
	(degree)	0°12'±24'				
Camber angle*2 (reference value)	14, 15 inch wheel	-0°23'±1°	-0°25'±1°	-0°27'±1°	-0°29'±1°	-0°31'±1°
	16 inch wheel	-0°27'±1°	-0°29'±1°	-0°31'±1°	-0°32'±1°	-0°34'±1°
Thrust angle (reference value)		0°±48'				

\*1 : Engine coolant and engine oil are at specified levels. Spare tire, jack and tools are in designated positions.  
Adjust to the median when carrying out wheel alignment.

\*2 : Difference between left and right must not exceed 1°30'.

### Total Toe-in Adjustment

- Loosen the cam nut on the lateral link.
- Turn the adjusting cam bolt as indicated to adjust the toe-in.

	Left wheel	Right wheel
Toe-in direction	Counterclockwise	Clockwise
Toe-out direction	Clockwise	Counterclockwise

#### Note

- Turning the adjusting cam bolt one complete turn changes the toe-in **about 3.0 mm {0.12 in} (0°18')**.

- Tighten the cam nut.

#### Tightening torque

**50—69 N·m {5.1—7.1 kgf·m, 37—50 ft·lbf}**

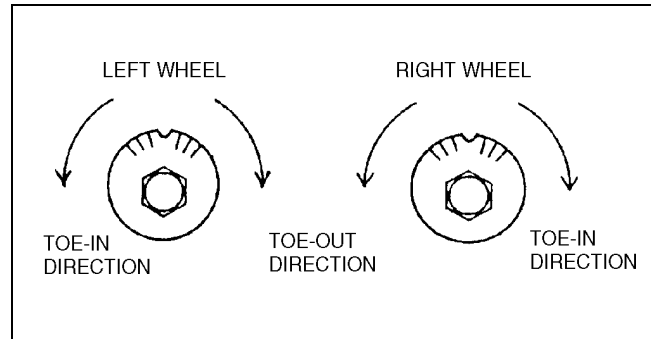

Z3U0211W005

02-11

# 02-13 FRONT SUSPENSION

## FRONT SUSPENSION LOCATION

**INDEX** ..... 02-13-1

**FRONT SHOCK ABSORBER AND COIL SPRING REMOVAL/INSTALLATION**.. 02-13-2

    Piston Rod Nut Removal Note..... 02-13-3

    Coil Spring Installation Note..... 02-13-3

    Front Shock Absorber and Spring Installation Note..... 02-13-4

**FRONT SHOCK ABSORBER INSPECTION**..... 02-13-4

**FRONT SHOCK ABSORBER DISPOSAL**..... 02-13-4

**FRONT LOWER ARM REMOVAL/INSTALLATION** ..... 02-13-5

    Dust Boot Removal Note ..... 02-13-5

    Lower Arm Bushing (Front) Removal Note ..... 02-13-5

    Lower Arm Bushing (Rear) Removal Note ..... 02-13-6

    Lower Arm Bushing (Rear) Installation Note..... 02-13-6

    Lower Arm Bushing (Front) Installation Note..... 02-13-6

    Dust Boot Installation Note ..... 02-13-7

**FRONT LOWER ARM INSPECTION** ... 02-13-7

**FRONT STABILIZER REMOVAL/INSTALLATION**..... 02-13-7

    Stabilizer Bracket Installation Note ... 02-13-8

**STABILIZER CONTROL LINK (FRONT) INSPECTION** ..... 02-13-8

**FRONT CROSSMEMBER REMOVAL/INSTALLATION**..... 02-13-8

    Crossmember Component Removal Note..... 02-13-9

**TRANSVERSE MEMBER (ZM (ATX), FS) REMOVAL/INSTALLATION**..... 02-13-9

**FRONT STRUT BAR REMOVAL/INSTALLATION**..... 02-13-10

02-13

## FRONT SUSPENSION LOCATION INDEX

A3U021301015W01

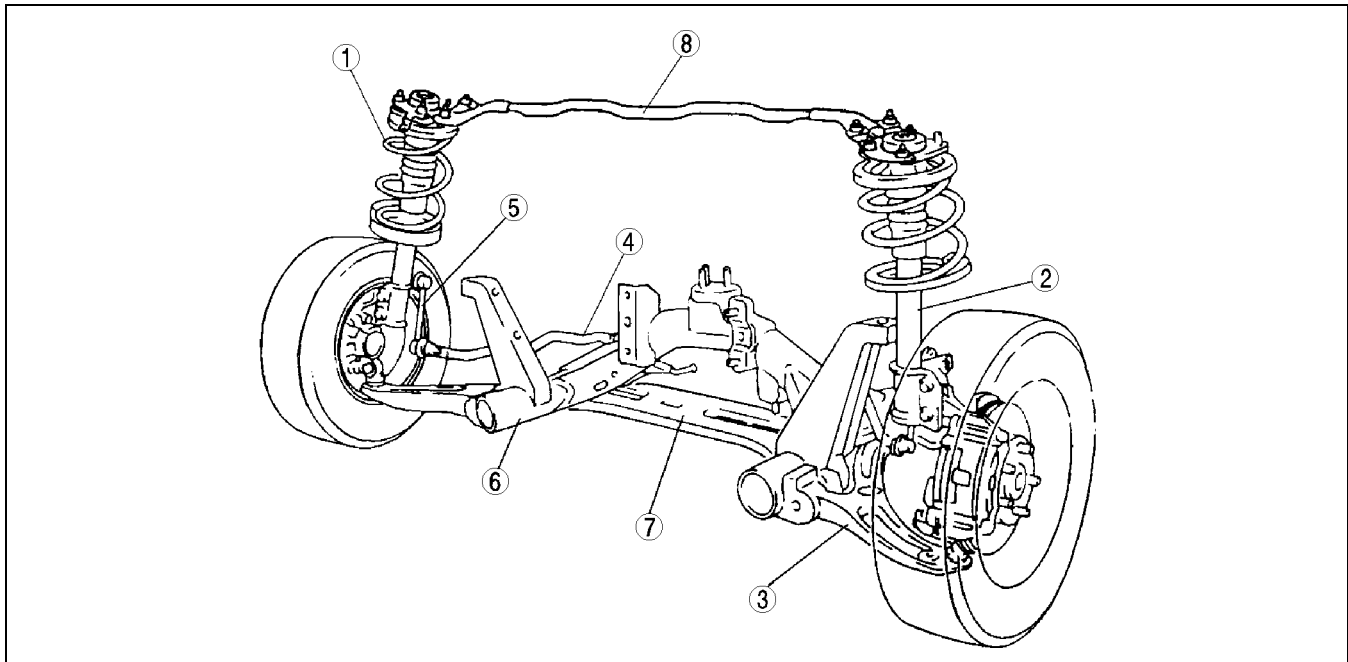

A3U0213W001

1	Front shock absorber and coil spring (See 02-13-2 FRONT SHOCK ABSORBER AND COIL SPRING REMOVAL/INSTALLATION)
2	Front shock absorber (See 02-13-4 FRONT SHOCK ABSORBER INSPECTION) (See 02-13-4 FRONT SHOCK ABSORBER DISPOSAL)
3	Front lower arm (See 02-13-5 FRONT LOWER ARM REMOVAL/INSTALLATION) (See 02-13-7 FRONT LOWER ARM INSPECTION)

4	Front stabilizer (See 02-13-7 FRONT STABILIZER REMOVAL/INSTALLATION)
5	Stabilizer control link (See 02-13-8 STABILIZER CONTROL LINK (FRONT) INSPECTION)
6	Front crossmember (See 02-13-8 FRONT CROSSMEMBER REMOVAL/INSTALLATION)
7	Transverse member (See 02-13-9 TRANSVERSE MEMBER (ZM (ATX), FS) REMOVAL/INSTALLATION)
8	Front strut bar (5HB only) (See 02-13-10 FRONT STRUT BAR REMOVAL/INSTALLATION)

# FRONT SUSPENSION

## FRONT SHOCK ABSORBER AND COIL SPRING REMOVAL/INSTALLATION

A3U021304910W01

### Caution

- Performing the following procedures without first removing the ABS wheel-speed sensor may possibly cause an open circuit in the harness if it is pulled by mistake. Before performing the following procedures, remove the ABS wheel-sensor (axle side) and set it to an appropriate place where the sensor will not be pulled by mistake while servicing the vehicle.

- Remove in the order indicated in the table.
- Install in the reverse order of removal.
- Inspect the front wheel alignment.
  - If not as specified, adjust the front wheel alignment. (See 02-11-1 FRONT WHEEL ALIGNMENT.)

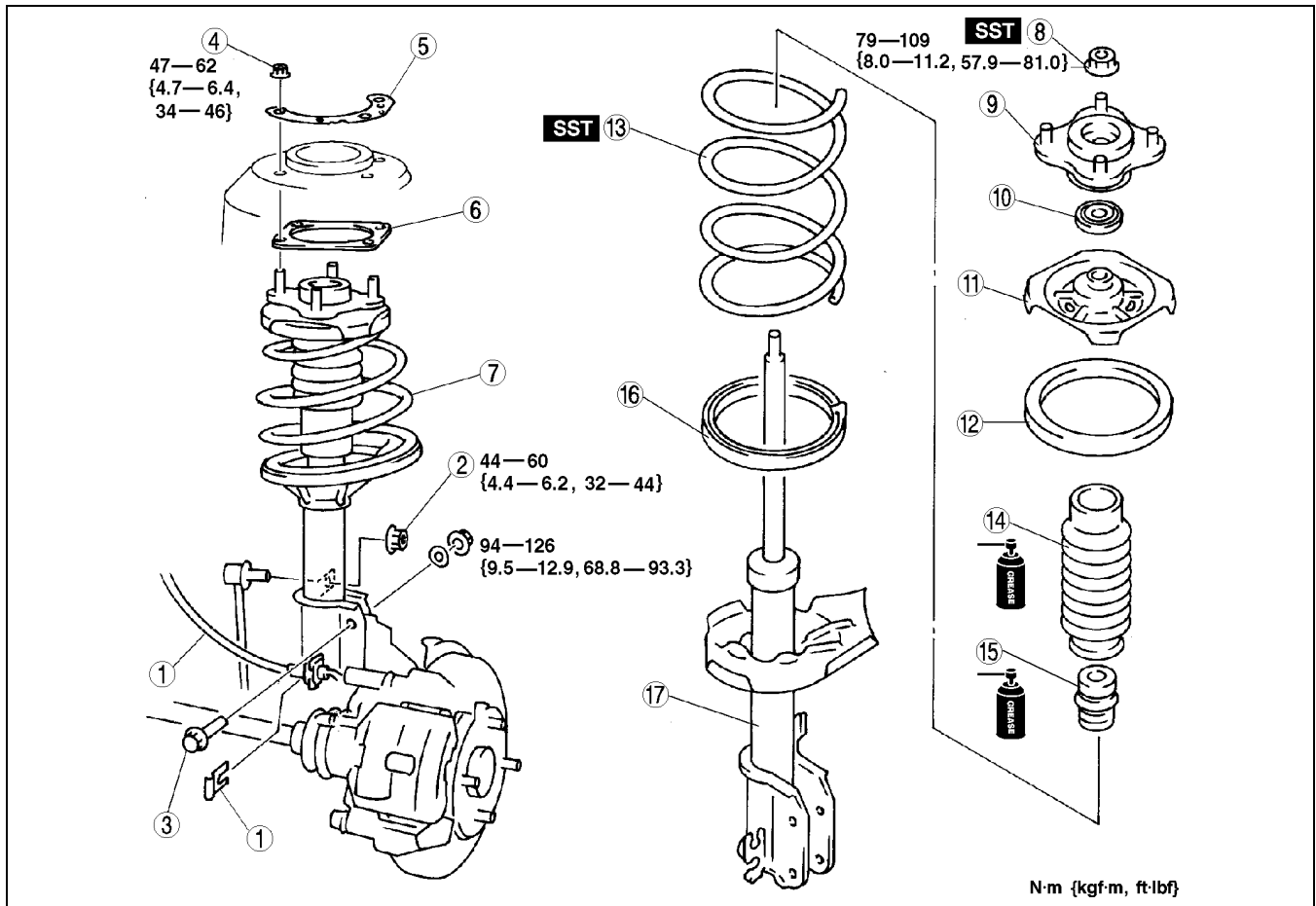

Z3U0213W002

1	Clip and brake hose
2	Nut (Stabilizer control link)
3	Shock absorber bolt
4	Nut
5	Stiffener
6	Sheet
7	Front shock absorber and spring (See 02-13-4 Front Shock Absorber and Spring Installation Note)
8	Piston rod nut (See 02-13-3 Piston Rod Nut Removal Note)

9	Mounting rubber
10	Bearing
11	Upper spring seat
12	Upper spring seat rubber
13	Coil spring (See 02-13-3 Coil Spring Installation Note)
14	Dust Boot
15	Bound stopper
16	Lower spring seat rubber
17	Shock absorber

# FRONT SUSPENSION

## Piston Rod Nut Removal Note

1. Protect the coil spring using a piece of cloth, then set the **SSTs**.

### Warning

- Removing the piston rod nut is dangerous. The shock absorber and spring could fly off under tremendous pressure and cause serious injury or death. Secure the shock absorber in the **SSTs** before removing the coil spring nut.

2. Compress the coil spring using the **SSTs**, and remove the piston rod nut.

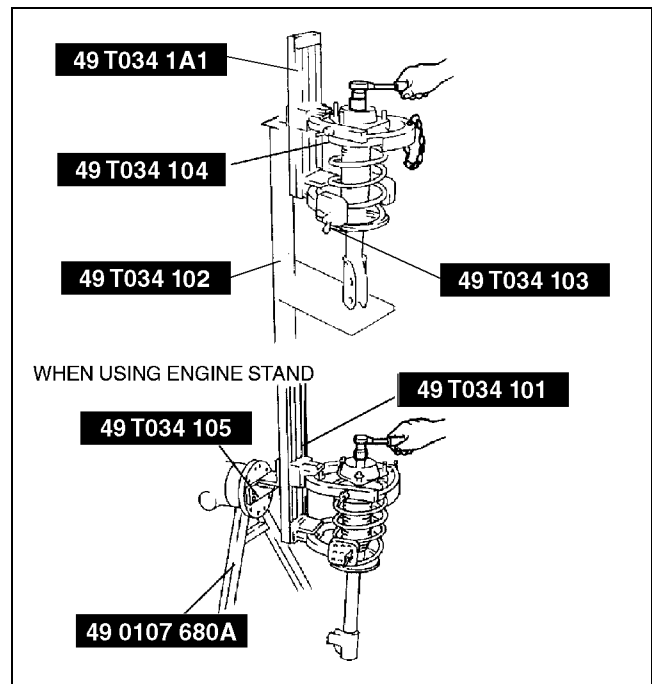

Z3U0213W003

02-13

## Coil Spring Installation Note

1. Temporarily install the coil spring, upper spring seat rubber and upper spring seat on the shock absorber so that the lower end of the coil spring is seated on the step of the lower spring seat.
2. Mark the coil spring, upper spring seat rubber and upper spring seat for proper installation as shown in the figure.
3. Align the marks of the coil spring, upper spring seat rubber and upper spring seat. Protect the coil spring and upper seat spring using a piece of cloth, then set the **SSTs**.

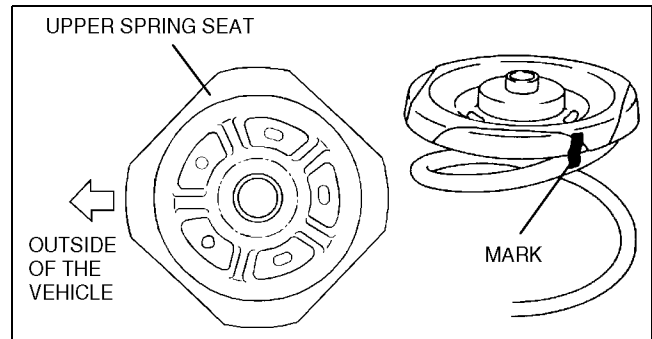

Z3U0213W004

4. Compress the coil spring using the **SSTs**.
5. Install the lower spring seat rubber on the lower spring seat.
6. Install the shock absorber so that the lower end of the coil spring is seated on the step of the lower spring seat.
7. Make sure that the marks on the shock absorber and upper spring seat are aligned.
8. Install the bearing, mounting rubber, and piston rod nut as shown in the figure, then remove the **SSTs**.

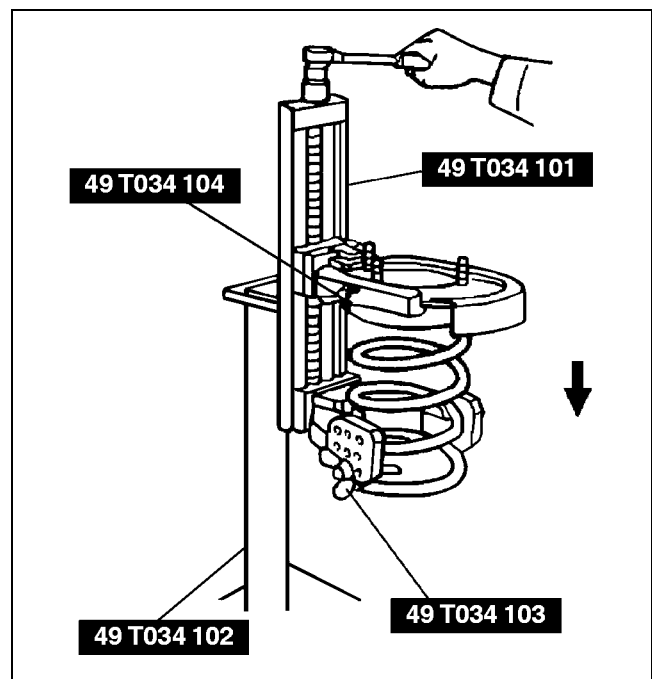

Z3U0213W005



## FRONT SUSPENSION

### Piston rod nut tightening torque

79—109 N·m {8.0—11.2 kgf·m, 57.9—81.0 ft·lbf}

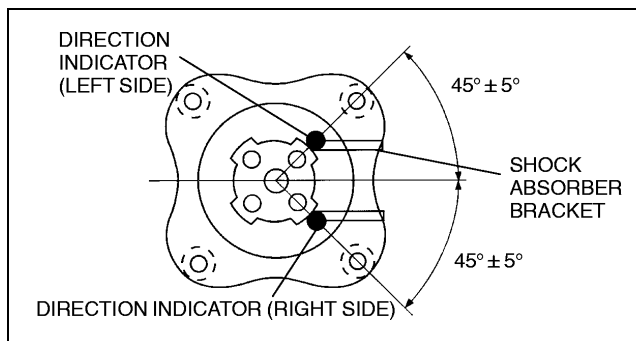

X3U213WA4

### Front Shock Absorber and Spring Installation Note

1. Face the mounting block direction indicator toward the rear outboard position, and install the shock absorber.

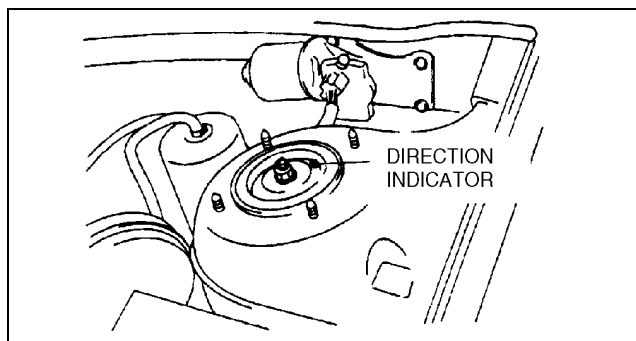

Z3U0213W006

### FRONT SHOCK ABSORBER INSPECTION

A3U021334700W01

1. Remove the front shock absorber from the vehicle.
2. Inspect for damage and oil leakage.
3. Inspect the rubber bushing for deterioration and wear.
4. Compress and extend the shock piston at least **3 times**. Verify that the operational force does not change and that there is no unusual noise.
  - (1) Compress the shock absorber piston and release it.
  - (2) Verify that the piston extends fully at a normal speed.
    - If not as specified, replace the shock absorber.

### FRONT SHOCK ABSORBER DISPOSAL

A3U021334700W02

#### Warning

- Whenever drilling into a shock absorber, wear protective eye wear. The gas in the shock absorber is pressurized, and could spray metal chips into the eyes and face when drilling.

1. Clamp a shock absorber flat or with the piston downwards.
2. Drill a **2—3 mm {0.08—0.11 in}** hole at a point **20—30 mm {0.8—1.1 in}** from the bottom of the tube, so that the gas can escape.
3. Turn the hole downwards.
4. The oil can be collected by moving the piston rod several times up and down and cutting the tube at the end.
5. Dispose of waste oil according to the waste disposal law.

#### Note

- Shock absorber gas is nitrogen gas.
- Shock absorber oil is mineral oil.

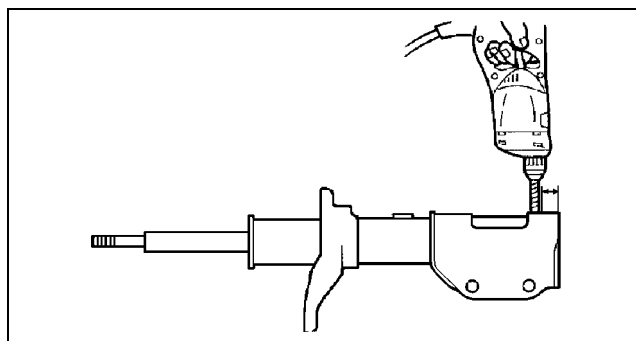

Z3U0213W007

# FRONT SUSPENSION

## FRONT LOWER ARM REMOVAL/INSTALLATION

A3U021334300W01

1. Remove in the order indicated in the table.

1	Bolt
2	Bolt (Lower arm ball joint)
3	Bracket
4	Lower arm component
5	Stopper
6	Dust boot (See 02-13-5 Dust Boot Removal Note) (See 02-13-7 Dust Boot Installation Note)
7	Lower arm bushing (front) (See 02-13-5 Lower Arm Bushing (Front) Removal Note) (See 02-13-6 Lower Arm Bushing (Front) Installation Note)
8	Lower arm bushing (rear) (See 02-13-6 Lower Arm Bushing (Rear) Removal Note) (See 02-13-6 Lower Arm Bushing (Rear) Installation Note)

2. Install in the reverse order of removal.

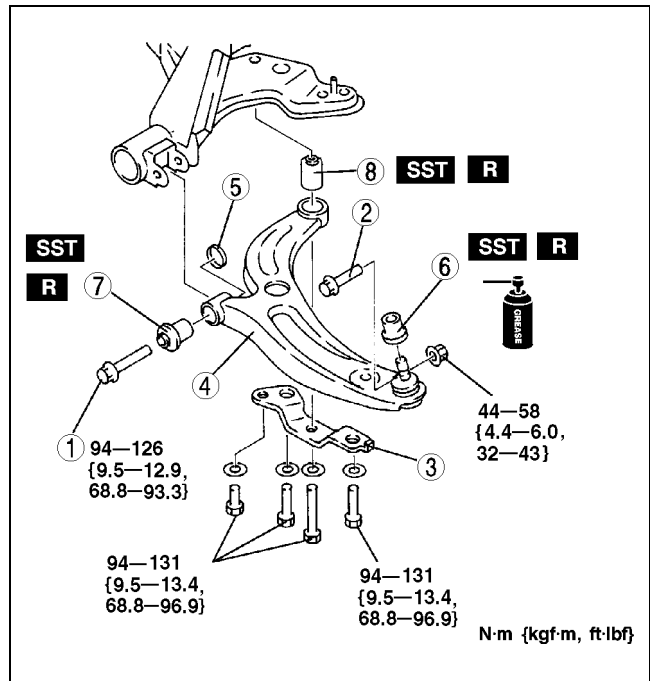

Z3U0213W008

### Dust Boot Removal Note

1. Remove the dust boot using a chisel, being careful not to damage the ball joint and the arm.

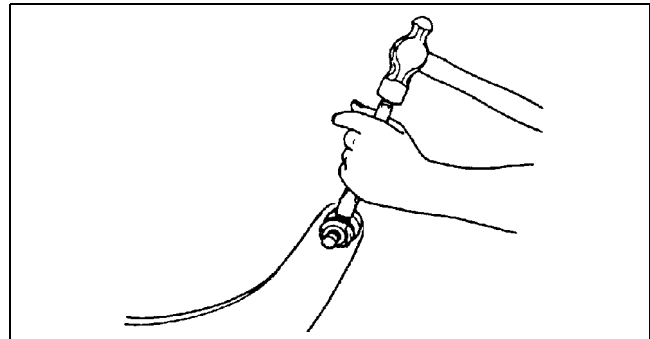

Z3U0213W009

### Lower Arm Bushing (Front) Removal Note

1. Cut away the projecting rubber of the lower arm bushing.  
2. Set the **SST** onto the lower arm, and remove the bushing.

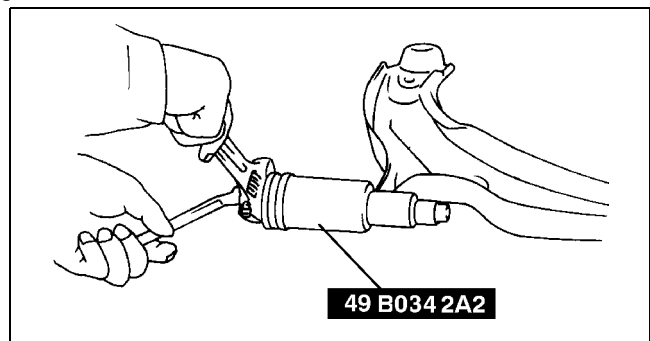

A3U0213W003

02-13

## FRONT SUSPENSION

### Lower Arm Bushing (Rear) Removal Note

1. Remove the lower arm bushing using the **SSTs** and a press.

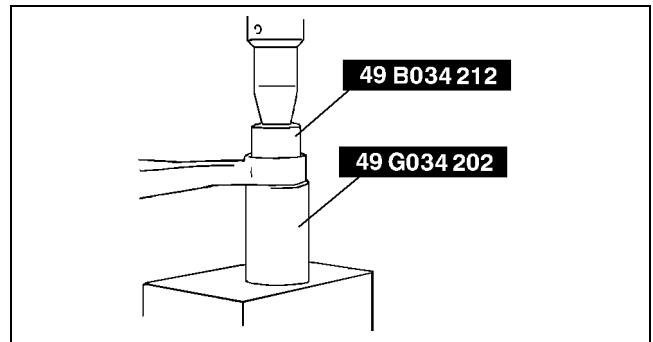

A3U0213W004

### Lower Arm Bushing (Rear) Installation Note

1. Align the mark of the lower arm and the small projection of the lower arm bushing (rear) as shown in the figure.
2. Set the lower arm onto the **SST** (49 B034 211).

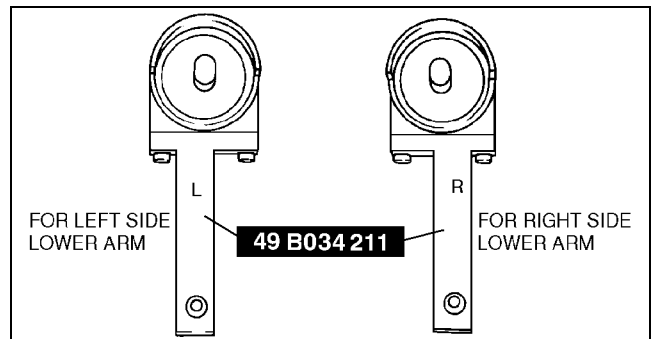

A3U0213W005

3. Press the new lower arm bushing using the **SST** (49 B034 212).

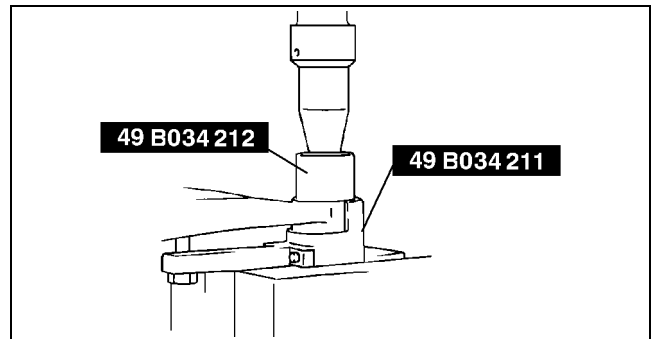

A3U0213W006

### Lower Arm Bushing (Front) Installation Note

1. Install the new bushing, and pull it into the lower arm using the **SST**.

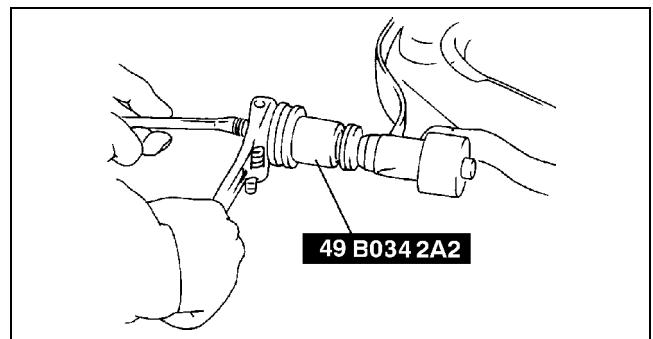

A3U0213W007

# FRONT SUSPENSION

## Dust Boot Installation Note

1. Wipe the grease off the ball stud.
2. Fill the inside of the new dust boot with grease.
3. Press the boot onto the ball joint using the **SST**.
4. Wipe away the excess grease.

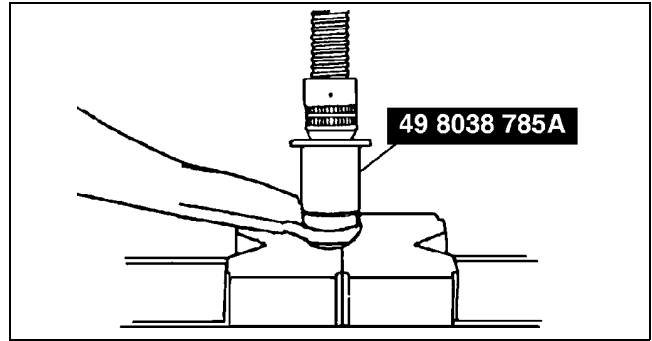

Z3U0213W015

02-13

## FRONT LOWER ARM INSPECTION

1. Remove the lower arm from the vehicle.
2. Inspect for damage, cracks, and bending.
3. Inspect the ball joint rotation torque.
  - (1) Rotate the ball joint **5 times**.
  - (2) Connect the **SST** to the ball stud, and measure the rotation torque using a pull scale.
    - Replace it if not within the specification.

### Ball joint preload

1.0—4.9 N·m {10—50 kgf·cm, 9—43 in·lbf}

### Pull scale reading

14—44 N {1.4—4.5 kgf, 3—10 lbf}

A3U021334300W02

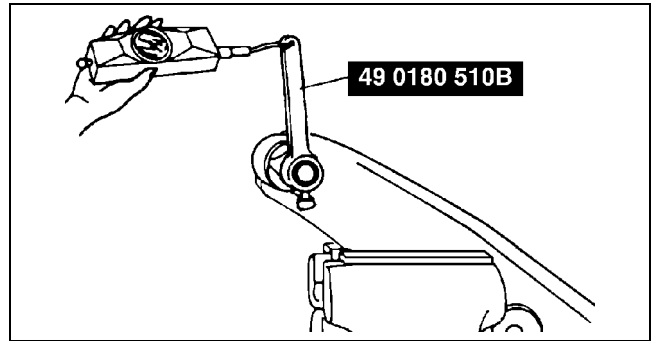

A3U0213W008

## FRONT STABILIZER REMOVAL/INSTALLATION

1. Remove the crossmember. (See 02-13-8 FRONT CROSSMEMBER REMOVAL/INSTALLATION.)
2. Remove in the order indicated in the table.

A3U021334100W01

1	Stabilizer control link
2	Stabilizer bracket (See 02-13-8 Stabilizer Bracket Installation Note)
3	Stabilizer bushing
4	Front stabilizer

3. Install in the reverse order of removal.
4. Inspect the front wheel alignment and adjust it if necessary.

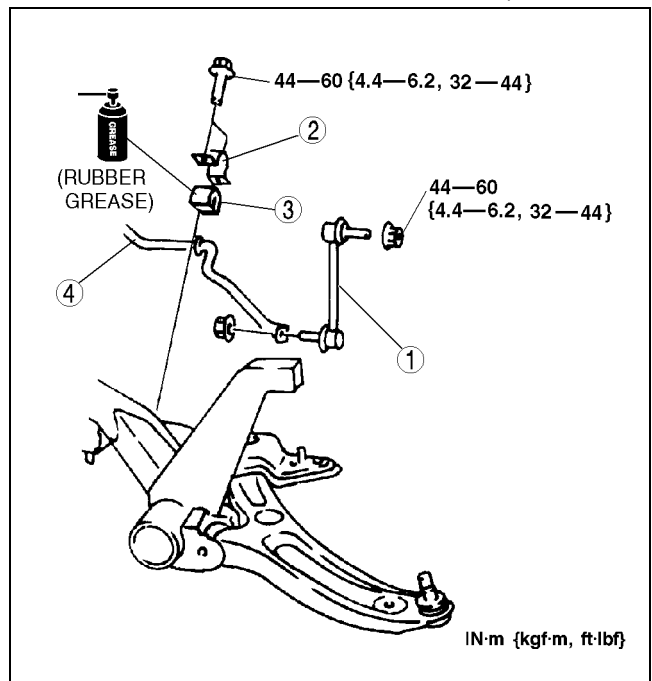

Z3U0213W016

## FRONT SUSPENSION

### Stabilizer Bracket Installation Note

1. Apply rubber grease to the inside surface of the stabilizer bushing.
2. Align the bushing with the inside of positioning plate on the stabilizer bar.

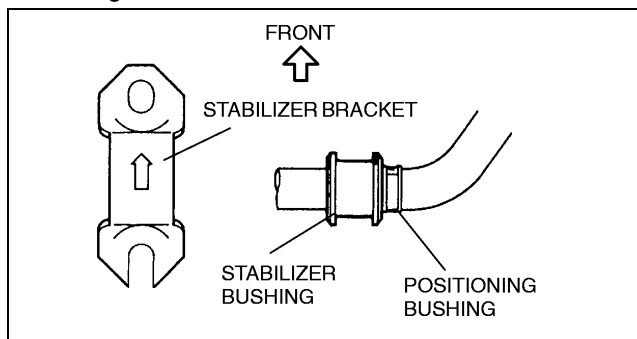

X3U213WAH

3. Install the stabilizer bracket.

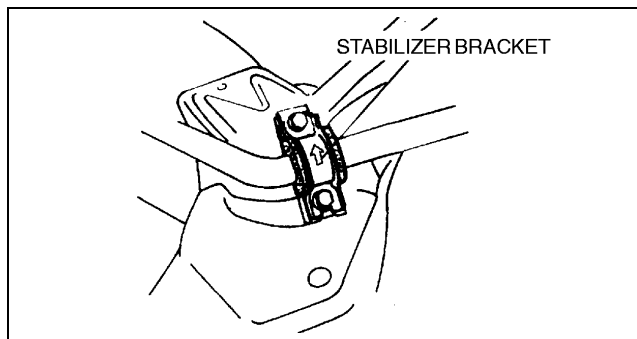

X3U213WAJ

### STABILIZER CONTROL LINK (FRONT) INSPECTION

A3U021334150W01

1. Remove the stabilizer control link from the vehicle.
2. Inspect for bending and damage.
3. Measure the ball joint starting torque.
  - (1) Rock the ball joint stud side to side **10 times**.
  - (2) Rotate the ball joint stud **10 times**.
  - (3) Measure the starting torque using a suitable Allen socket and a torque wrench.

#### Starting torque

0.2—2.5 N·m {1.4—26.0 kgf·cm, 1.3—22.0 in·lbf}

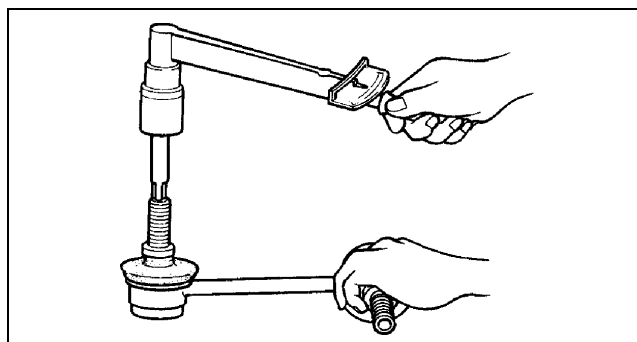

X3U213WAK

### FRONT CROSSMEMBER REMOVAL/INSTALLATION

A3U021334800W01

1. For the MTX models, remove the change control rod and extension bar. (See 05-15A-4 MANUAL TRANSAXLE (MTX) REMOVAL/INSTALLATION [F25M-R].)
2. Remove the front exhaust pipe. (See 01-15-1 EXHAUST SYSTEM REMOVAL/INSTALLATION.) (See 01-15-1 EXHAUST SYSTEM REMOVAL/INSTALLATION.)
3. Remove the transverse member. (See 02-13-9 TRANSVERSE MEMBER (ZM (ATX), FS) REMOVAL/INSTALLATION)
4. Remove the steering gear and linkage. (See 06-12-9 STEERING GEAR AND LINKAGE REMOVAL/INSTALLATION.)
5. Remove the front lower arm. (See 02-13-5 FRONT LOWER ARM REMOVAL/INSTALLATION.)

# FRONT SUSPENSION

6. Remove in the order indicated in the table.

1	Crossmember component (See 02-13-9 Crossmember Component Removal Note)
2	Front stabilizer (See 02-13-7 FRONT STABILIZER REMOVAL/INSTALLATION)
3	Front crossmember

7. Install in the reverse order of removal.
8. Inspect the front wheel alignment as necessary.

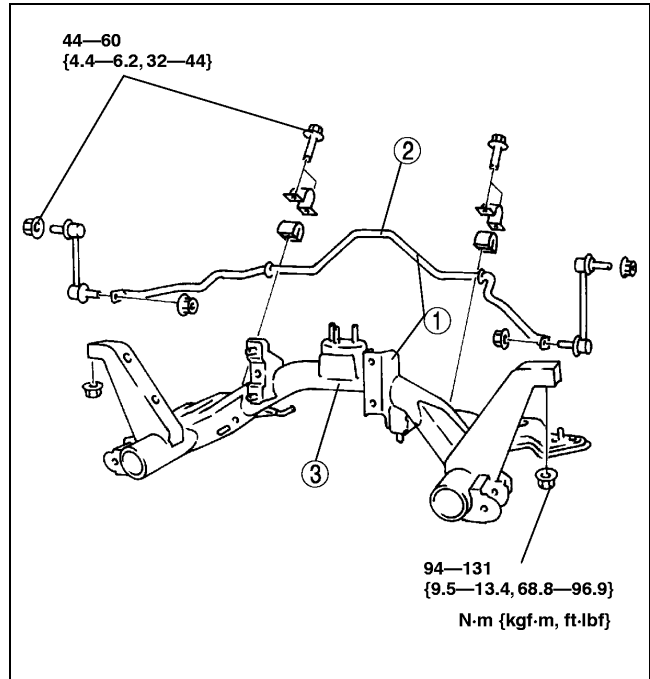

X3U213WAL

02-13

## Crossmember Component Removal Note

1. Support the crossmember using a jack and remove the bolts and nuts.
2. Remove the crossmember component.

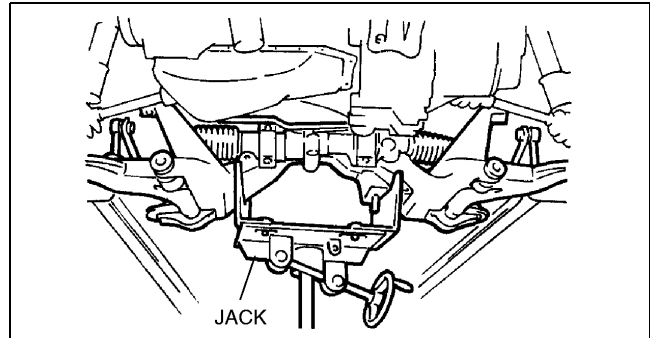

X3U213WAM

## TRANSVERSE MEMBER (ZM (ATX), FS) REMOVAL/INSTALLATION

A3U021334890W01

1. Remove the transverse member.
2. Install the transverse member.

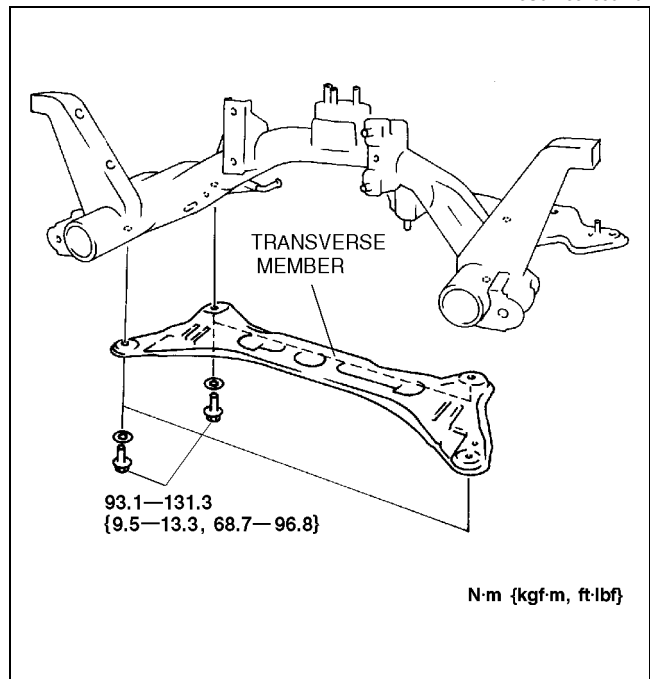

Y3E7414W001

# FRONT SUSPENSION

## FRONT STRUT BAR REMOVAL/INSTALLATION

A3U021301015W02

1. Remove in the order indicated in the table.

1	Nut
2	Front strut bar

2. Install in the reverse order of removal.

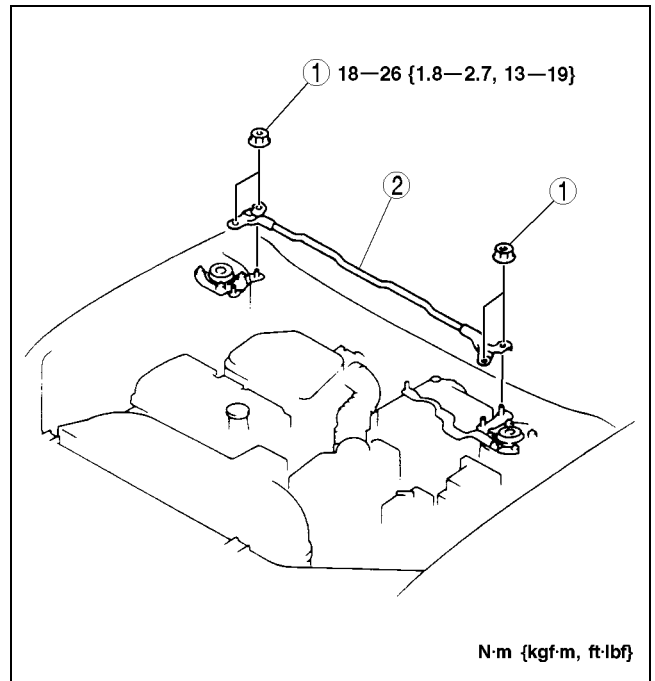

Y3A7414W002

# 02-14 REAR SUSPENSION

**REAR SUSPENSION**

**LOCATION INDEX** ..... 02-14-1

**REAR SHOCK ABSORBER AND SPRING REMOVAL/INSTALLATION**.. 02-14-2  
 Coil Spring Installation Note..... 02-14-3

**REAR SHOCK ABSORBER INSPECTION**..... 02-14-3

**REAR SHOCK ABSORBER DISPOSAL**..... 02-14-3

**REAR STABILIZER REMOVAL/INSTALLATION** ..... 02-14-4

Stabilizer Bushing and Bracket Installation Note .....02-14-4

**STABILIZER CONTROL LINK (REAR) INSPECTION** .....02-14-4

**LATERAL LINK AND TRAILING LINK REMOVAL/INSTALLATION**.....02-14-5  
 Nut, Cam Plate and Adjusting Cam Bolt Removal Note .....02-14-5  
 Front Lateral Link Removal Note .....02-14-6  
 Nut, Cam Plate, and Adjusting Cam Bolt Installation Note.....02-14-6

02-14

**REAR SUSPENSION LOCATION INDEX**

A3U021401016W01

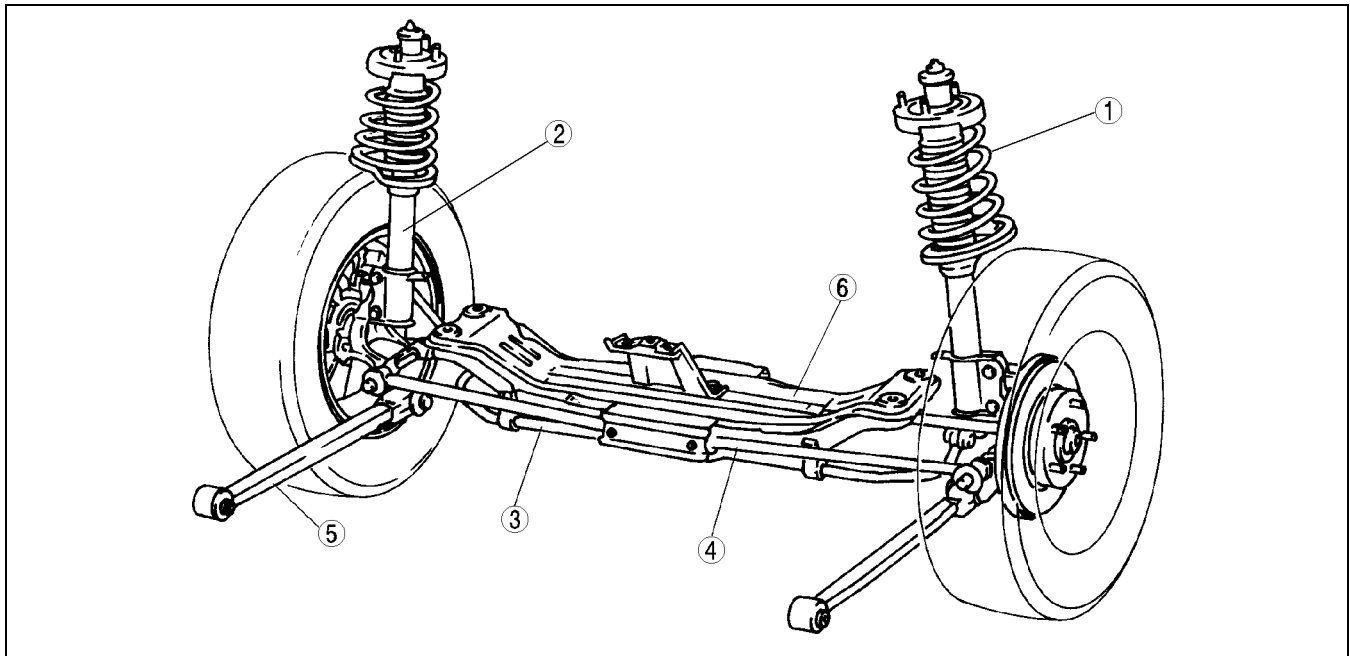

Z3U0214W001

1	Rear shock absorber and coil spring (See 02-14-2 REAR SHOCK ABSORBER AND SPRING REMOVAL/INSTALLATION)
2	Rear shock absorber (See 02-14-3 REAR SHOCK ABSORBER INSPECTION) (See 02-14-3 REAR SHOCK ABSORBER DISPOSAL)
3	Rear stabilizer and stabilizer control link (See 02-14-4 REAR STABILIZER REMOVAL/INSTALLATION) (See 02-14-4 STABILIZER CONTROL LINK (REAR) INSPECTION)

4	Lateral link (See 02-14-5 LATERAL LINK AND TRAILING LINK REMOVAL/INSTALLATION)
5	Trailing link (See 02-14-5 LATERAL LINK AND TRAILING LINK REMOVAL/INSTALLATION)
6	Rear crossmember (See 02-14-6 REAR CROSSMEMBER REMOVAL/INSTALLATION)



# REAR SUSPENSION

## REAR SHOCK ABSORBER AND SPRING REMOVAL/INSTALLATION

A3U021405910W01

### Caution

- Performing the following procedures without first removing the ABS wheel-speed sensor may possibly cause an open circuit in the harness if it is pulled by mistake. Before performing the following procedures, remove the ABS wheel-speed sensor (axle side) and set it to an appropriate place where the sensor will not be pulled by mistake while servicing the vehicle.

- For the 4SD, remove the rear seat belt. (See 08-11-2 REAR SEAT BELT REMOVAL/INSTALLATION.) For the 5HB, remove the trunk side trim. (See 09-17-15 TRUNK SIDE TRIM REMOVAL/INSTALLATION)
- Remove in the order indicated in the table.
- Install in the reverse order of removal.

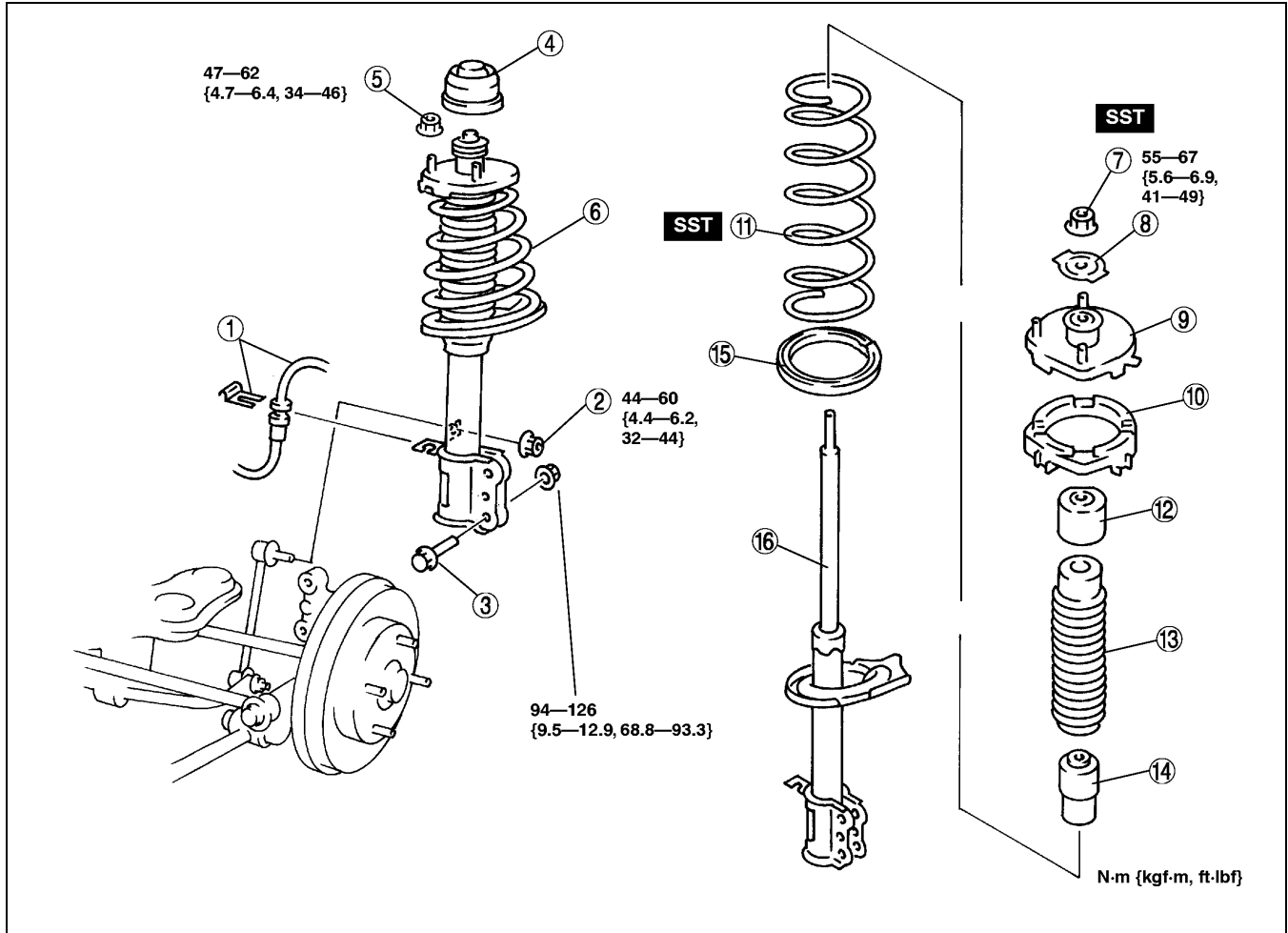

X3U214WA0

1	Clip and brake hose
2	Stabilizer control link nut
3	Shock absorber bolt
4	Cap
5	Nut
6	Rear shock absorber and spring
7	Piston rod nut (See 02-13-3 Piston Rod Nut Removal Note)
8	Washer

9	Mounting rubber
10	Upper spring seat
11	Coil spring (See 02-14-3 Coil Spring Installation Note)
12	Stopper seat
13	Dust cover
14	Bound stopper
15	Lower spring seat rubber
16	Rear shock absorber

## REAR SUSPENSION

### Coil Spring Installation Note

1. Temporarily install the coil spring, upper spring seat and mounting rubber on the shock absorber so that the lower end of the coil spring is seated on the step of the lower spring seat.
2. Mark the coil spring, upper spring seat and mounting rubber for proper installation as shown in the figure. (The following figure shows how to install the right side. Install the left side symmetrically.)
3. Align the marks of the coil spring and upper spring seat rubber. Protect the coil spring and upper seat spring using a piece of cloth, then set the **SSTs**.

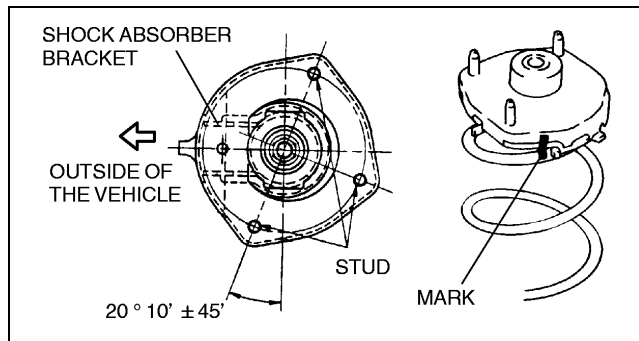

X3U214WA1

4. Compress the coil spring using the **SSTs**.
5. Install the lower spring seat rubber on the lower spring seat.
6. Install the shock absorber so that the lower end of the coil spring is seated on the step of the lower spring seat.
7. Align the marks of the mounting rubber and shock absorber.
8. Install the washer and piston rod nut, then remove the **SSTs**.

### Piston rod nut tightening torque

55—67 N·m {5.6—6.9 kgf·m, 41—49 ft·lbf}

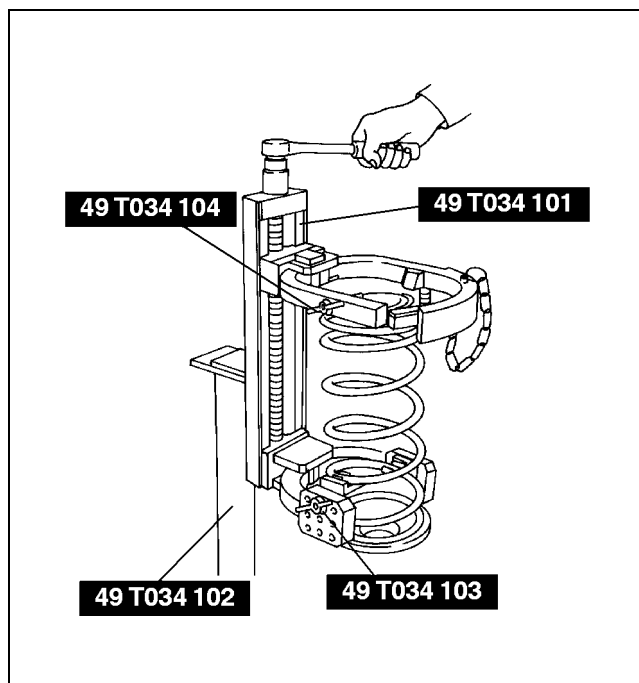

A3U0214W001

### REAR SHOCK ABSORBER INSPECTION

1. Inspect the rear shock absorber using the same procedure as the front shock absorber. (See 02-13-4 FRONT SHOCK ABSORBER INSPECTION.)

A3U021428700W01

### REAR SHOCK ABSORBER DISPOSAL

1. Dispose of the rear shock absorber using the same procedure as the front shock absorber. (See 02-13-4 FRONT SHOCK ABSORBER DISPOSAL.)

A3U021428700W02

02-14

# REAR SUSPENSION

## REAR STABILIZER REMOVAL/INSTALLATION

A3U021428100W01

1. Remove in the order indicated in the table.

1	Stabilizer control link
2	Stabilizer bushing and bracket (See 02-14-4 Stabilizer Bushing and Bracket Installation Note)
3	Rear stabilizer

2. Install in the reverse order of removal.

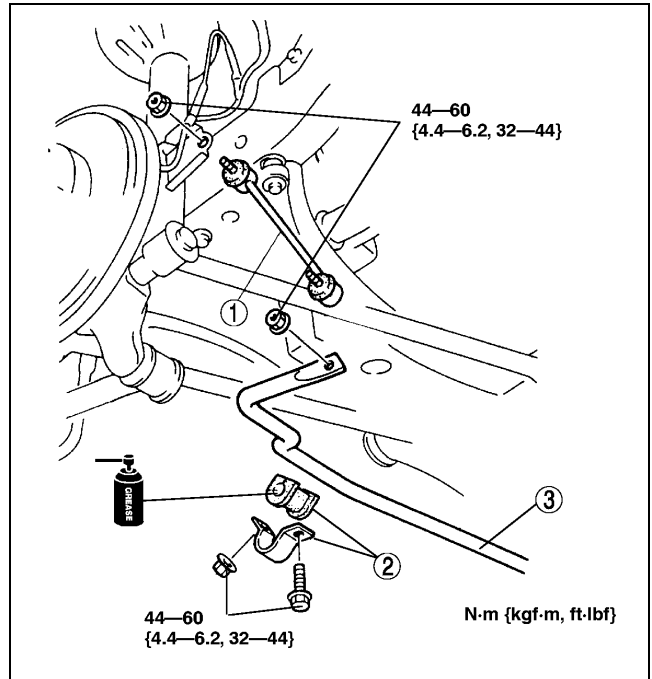

X3U214WA3

### Stabilizer Bushing and Bracket Installation Note

1. Align the bushing with the positioning bushing on the stabilizer bar.
2. Temporarily install the stabilizer bracket so that the slot (or elongated hole) faces downward.
3. Tighten the stabilizer bracket nut, then bolt.

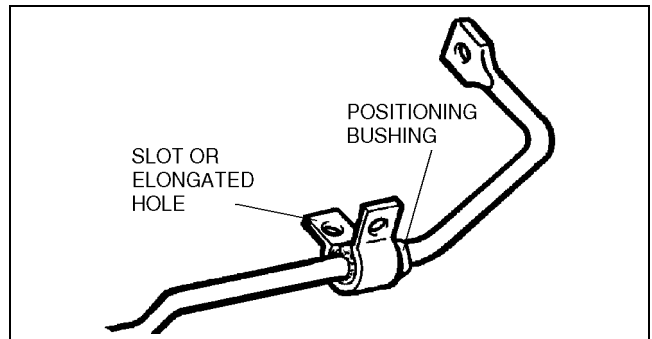

Z3U0214W101

### STABILIZER CONTROL LINK (REAR) INSPECTION

A3U021434150W01

1. Inspect the rear stabilizer control link in the same procedure as the front stabilizer control link inspection.  
(See 02-13-8 STABILIZER CONTROL LINK (FRONT) INSPECTION.)

# REAR SUSPENSION

## LATERAL LINK AND TRAILING LINK REMOVAL/INSTALLATION

A3U021428600W01

### Caution

- Performing the following procedures without first removing the ABS wheel-speed sensor may possibly cause an open circuit in the harness if it is pulled by mistake. Before performing the following procedures, remove the ABS wheel-speed sensor (axle side) and fix it to an appropriate place where the sensor will not be pulled by mistake while servicing the vehicle.

- Remove in the order indicated in the table.
- Install in the reverse order of removal.
- Inspect the rear wheel alignment and adjust it as necessary.

02-14

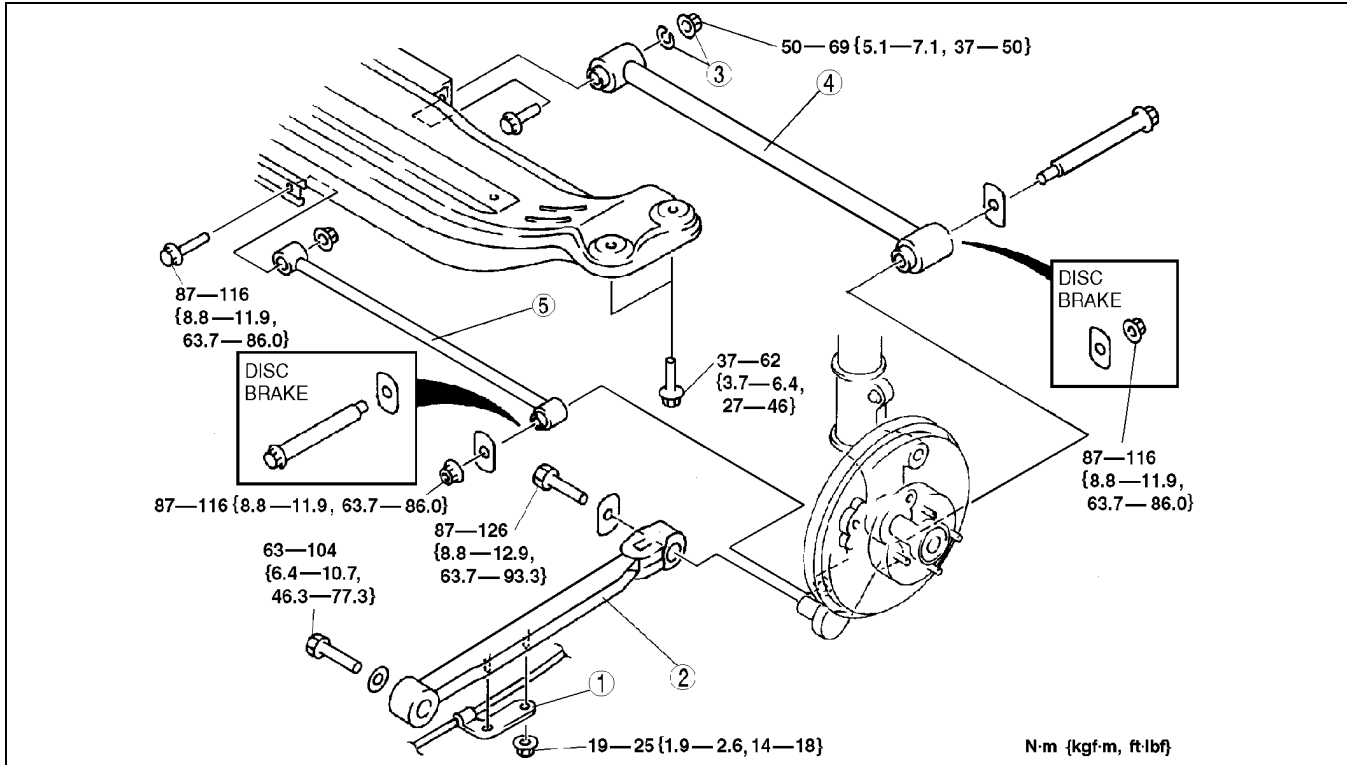

Z3U0214W006

1	Parking brake cable bracket
2	Trailing link
3	Nut, cam plate and adjusting cam bolt (See 02-14-5 Nut, Cam Plate and Adjusting Cam Bolt Removal Note) (See 02-14-6 Nut, Cam Plate, and Adjusting Cam Bolt Installation Note)

4	Rear lateral link
5	Front lateral link (See 02-14-6 Front Lateral Link Removal Note)

### Nut, Cam Plate and Adjusting Cam Bolt Removal Note

- Before loosening the nut, make a mark on the cam plate and the crossmember for reference during installation.

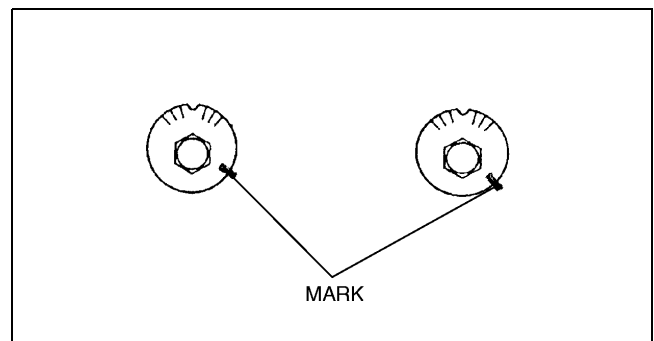

Y3U214WA1

## REAR SUSPENSION

### Front Lateral Link Removal Note

1. Support the rear crossmember using a jack, then remove the crossmember bolts.
2. Lower the crossmember to remove the lateral link bolt.

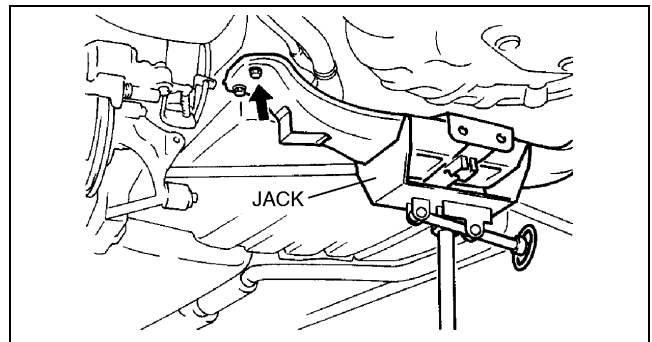

X3U214WA7

### Nut, Cam Plate, and Adjusting Cam Bolt Installation Note

1. Install the cam plate so that the notch faces the same direction as the adjusting cam bolt.
2. Align with the mark made before removing the adjusting cam bolt.
3. Tighten the nut.

### Tightening torque

50—69 N·m {5.1—7.1 kgf·m, 37—50 ft·lbf}

### REAR CROSSMEMBER REMOVAL/INSTALLATION

A3U021428400W01

1. Remove the rear stabilizer. (See 02-14-4 REAR STABILIZER REMOVAL/INSTALLATION.)
2. Remove the front and rear lateral links. (See 02-14-5 LATERAL LINK AND TRAILING LINK REMOVAL/INSTALLATION.)
3. Remove in the order indicated in the table.

1	Rear crossmember
2	Crossmember bracket

4. Install in the reverse order of removal.
5. Inspect the rear wheel alignment and adjust it as necessary.

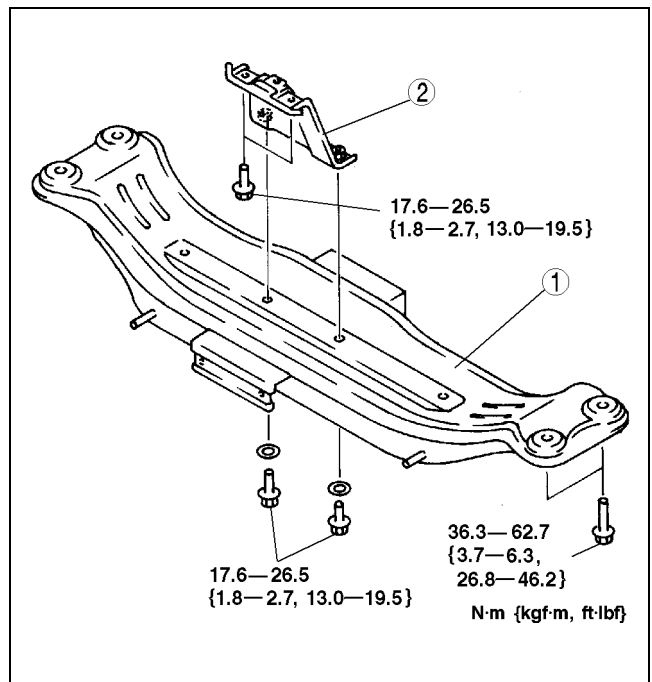

Z3U0214W100

# 02-50 TECHNICAL DATA

## SUSPENSION TECHNICAL DATA . . . . 02-50-1

### SUSPENSION TECHNICAL DATA

A3U025001013W01

Item		Specification			
<b>WHEEL ALIGNMENT</b>					
Front wheel alignment (Unloaded)*1	Maximum steering angle	Inner	37°±3°		
		Outer	33°±3°		
	Total toe-in	(mm {in})	2±4 {0.08±0.16}		
		(degree)	0°12'±24'		
	Camber angle*2		-0°49'±1°		
	Caster angle*2		1°56'±1°		
Kingpin angle (Reference value)		12°36'			
Rear wheel alignment (Unloaded)*1	Total toe-in	(mm {in})	2±4 {0.08±0.16}		
		(degree)	0°12'±24'		
	Camber angle*2 (Reference value)		-0°31'±1°(14,15inch wheel), -0°34'±1°(16inch wheel)		
	Thrust angle (Reference value)		0°±48'		
<b>WHEELS AND TIRES</b>					
Standard tire wheel	Size		14×5 1/2JJ	15×6JJ	16×6JJ
	Offset (mm {in})		45 {1.77}		50 {1.97}
	Pitch circle diameter (mm {in})		100 {3.94}		114.3 {4.50}
	Material		Steel	Steel or aluminum alloy	Aluminum alloy
Standard tire	Size		P185/65R14 85S	P195/55R15 84V	P195/50R16 83V
	Air pressure (kPa {kgf/cm <sup>2</sup> , psi})		220 {2.2, 32}		
	Remaining tread (mm {in})		1.6 {0.063}		
Standard tire wheel and tire	Wheel and tire runout	Radial direction (mm {in})	1.5 {0.06 max.}		
		Lateral direction (mm {in})	Steel: 2.5 {0.10} max., Aluminum: 2.0 {0.08} max.		
	Wheel unbalance*3 (g {oz})		10 {0.35} max.	9 {0.32} max.	8 {0.30} max.
Temporary spare tire wheel	Size		14×4T		15×4T
	Offset (mm {in})		40 {1.58}		45 {1.77}
	Pitch circle diameter (mm {in})		100 {3.94}		114.3 {4.50}
	Material		Steel		
Temporary spare tire	Size		T125/70 D14		T115/70 D15
	Air pressure (kPa {kgf/cm <sup>2</sup> , psi})		420 {4.2, 60}		
Temporary spare tire wheel and tire	Wheel and tire runout	Radial direction (mm {in})	2.0 {0.08} max.		
		Lateral direction (mm {in})	2.5 {0.10} max.		
<b>FRONT SUSPENSION</b>					
Lower arm ball joint rotation torque (Pull scale reading) (N {kgf, lbf})		14—44 {1.4—4.5, 3—10}			
Stabilizer control link rotation torque (N·m {kgf·cm, in·lbf})		0.2—2.5 {1.4—26.0, 1.3—22.0}			
<b>REAR SUSPENSION</b>					
Stabilizer control link rotation torque (N·m {kgf·cm, in·lbf})		0.2—2.5 {1.4—26.0, 1.3—22.0}			

\*1 : Fuel tank is full. Engine coolant and engine oil are at specified levels. Spare tire, jack and tools are in designated positions. Adjust to the median when carrying out wheel alignment.

\*2 : Difference between left and right must not exceed 1°30'.

\*3 : 1 balance weight: max. 60 g {2.12 oz}. If the total weight exceeds 100 g {3.53 oz} on one side, rebalance after moving the tire around on the rim. Do not use more than 2 balance weights on the inner or outer side of the wheel.





02-50

**02-60 SERVICE TOOLS**

SUSPENSION SST ..... 02-60-1

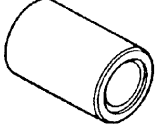
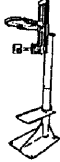
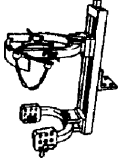
**SUSPENSION SST**

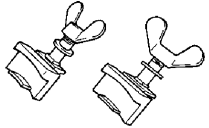
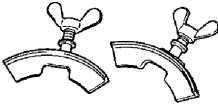
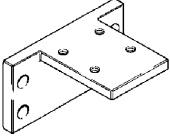
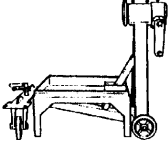
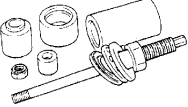
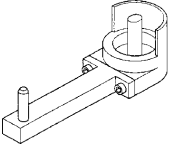
A3U026001013W01

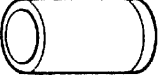
<p>49 0180 510B</p> <p>Preload measuring attachment</p> 	<p>49 8038 785A</p> <p>Dust boot installer</p> 	<p>49 T034 1A0</p> <p>Coil spring compressor set</p> 
<p>49 T034 101</p> <p>Spring compressor (Part of 49 T034 1A0)</p> 	<p>49 T034 102</p> <p>Stand (Part of 49 T034 1A0)</p> 	<p>49 T034 103</p> <p>Hook (Part of 49 T034 1A0)</p> 
<p>49 T034 104</p> <p>Support (Part of 49 T034 1A0)</p> 	<p>49 T034 105</p> <p>Attachment</p> 	<p>49 0107 680A</p> <p>Engine stand</p> 
<p>49 B034 2A2</p> <p>Rubber bushing replacer set</p> 	<p>49 B034 211</p> <p>Rubber bushing installer</p> 	<p>49 B034 212</p> <p>Rubber bushing replacer</p> 
<p>49 G034 202</p> <p>Support block</p> 	<p>—</p>	<p>—</p>

**02-60**

# DRIVELINE/AXLE

**03**  
SECTION

<b>GENERAL PROCEDURES . . . . .</b>	<b>03-10</b>	<b>DRIVE SHAFT . . . . .</b>	<b>03-13</b>
<b>FRONT AXLE . . . . .</b>	<b>03-11</b>	<b>TECHNICAL DATA . . . . .</b>	<b>03-50</b>
<b>REAR AXLE . . . . .</b>	<b>03-12</b>	<b>SERVICE TOOLS . . . . .</b>	<b>03-60</b>

03-10

## 03-10 GENERAL PROCEDURES

<b>PRECAUTION (DRIVELINE/AXLE) . . . . .</b>	<b>03-10-1</b>	<b>Suspension Arm</b>	
Wheel and Tire Removal/Installation . .	<b>03-10-1</b>	Removal/Installation . . . . .	<b>03-10-1</b>
Brake Line			
Disconnection/Connection . . . . .	<b>03-10-1</b>		

### PRECAUTION (DRIVELINE/AXLE)

A3U031001018W01

#### Wheel and Tire Removal/Installation

1. The removal and installation procedures for the wheels and tires are not mentioned in this section. When a wheel is removed, tighten it to **89—117 N·m {9.0—12.0 kgf·m, 65.1—86.7 ft·lbf}**.

#### Brake Line Disconnection/Connection

##### Caution

- **Brake fluid will damage painted surfaces. If brake fluid gets on a painted surface, wipe it off immediately.**

1. Tighten the brake pipe flare nut using the **SST** (49 0259 770B). Be sure to modify the brake pipe flare nut tightening torque to allow for use of a torque wrench-**SST** combination. (See 00-00-15 Torque Formulas.)
  - If any brake line has been disconnected any time during the procedure, add brake fluid, bleed the brakes, and inspect for leakage after the procedure has been completed.

#### Suspension Arm Removal/Installation

1. Tighten any part of the suspension that uses rubber bushings only after vehicle has been lowered and unloaded.

##### Note

- Unloaded ... Fuel tank is full. Engine coolant and engine oil are at specified level. Spare tire, jack, and tools are in designated position.



# 03-11 FRONT AXLE

**FRONT AXLE LOCATION INDEX** . . . . . 03-11-1

**WHEEL HUB, STEERING KNUCKLE**

**PRE-INSPECTION** . . . . . 03-11-1

    Wheel Bearing Play Inspection . . . . . 03-11-1

**WHEEL HUB BOLT REPLACEMENT** .. 03-11-2

**WHEEL HUB, STEERING KNUCKLE**

**REMOVAL/INSTALLATION** . . . . . 03-11-3

    Locknut Removal Note . . . . . 03-11-4

    Wheel Hub Component Removal Note . . . . . 03-11-4

Wheel Bearing Removal Note . . . . . 03-11-4

Dust Cover Removal Note . . . . . 03-11-5

Hub Bolt Removal Note . . . . . 03-11-5

Hub Bolt Installation Note . . . . . 03-11-5

Dust Cover Installation Note . . . . . 03-11-6

Wheel Bearing Installation Note . . . . . 03-11-6

Wheel Hub Component Installation Note . . . . . 03-11-6

Oil Seal Installation Note . . . . . 03-11-7

Locknut Installation Note . . . . . 03-11-7

## FRONT AXLE LOCATION INDEX

A3U031104000W01

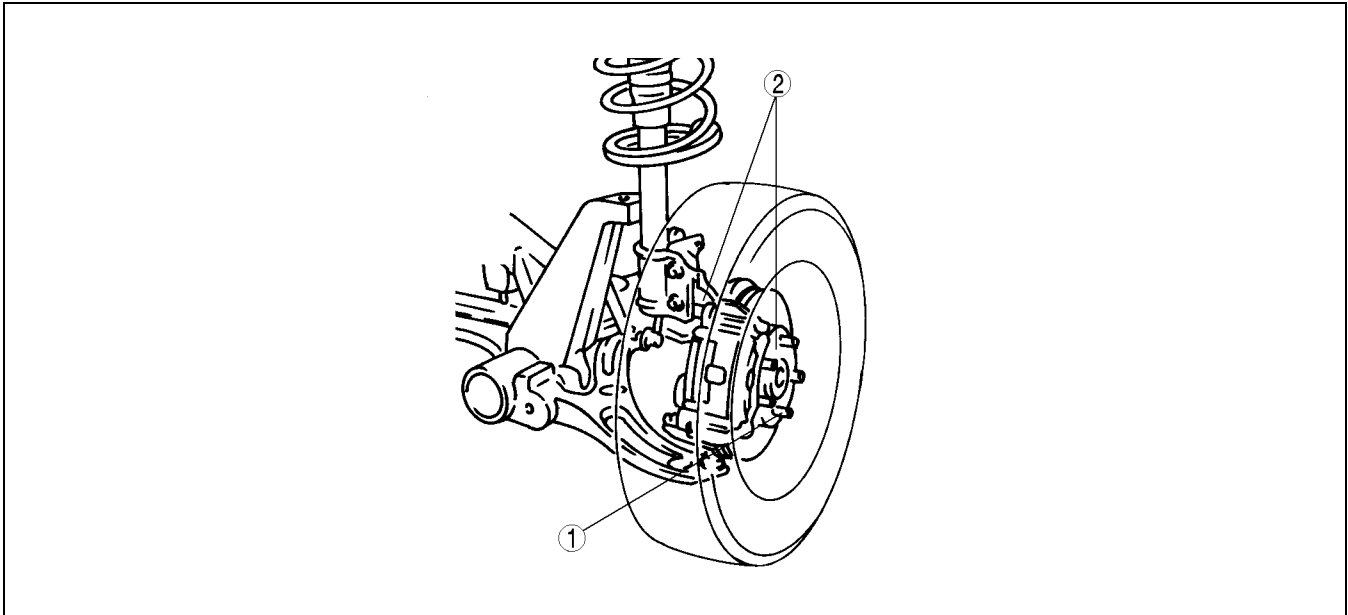

Z3U0311W001

1	Hub bolt (See 03-11-2 WHEEL HUB BOLT REPLACEMENT)
---	--

2	Wheel hub, steering knuckle (See 03-11-3 WHEEL HUB, STEERING KNUCKLE REMOVAL/INSTALLATION) (See 03-11-1 WHEEL HUB, STEERING KNUCKLE PRE-INSPECTION)
---	---

## WHEEL HUB, STEERING KNUCKLE PRE-INSPECTION

A3U031104000W02

### Wheel Bearing Play Inspection

1. Position a dial indicator against the wheel hub.
2. Push and pull the wheel hub by hand in the axial direction and measure the wheel bearing play.
  - If the bearing play exceeds the specification, replace the wheel bearing as necessary and tighten the locknut to the specified torque and retest.

**Maximum wheel bearing play**  
**0.05 mm {0.002 in}**

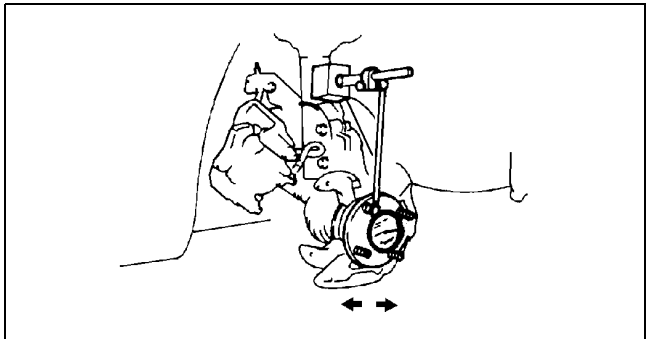

A3U0311W010

# FRONT AXLE

## WHEEL HUB BOLT REPLACEMENT

A3U031104000W03

1. Remove the hub bolt using the **SSTs**.

### Note

- If the dust cover interferes with the wheel hub bolt and the wheel hub bolt cannot be removed, tap the part shown in the figure with a chisel lightly and bend the processing point back to the steering knuckle side.

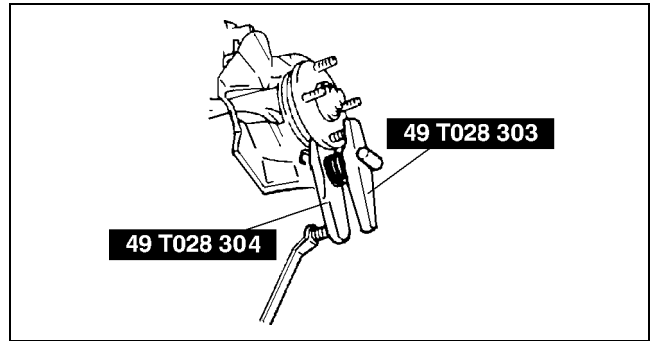

A3U0311W007

2. Install the hub bolt into the wheel hub and install a washer and hub nut on the hub bolt.

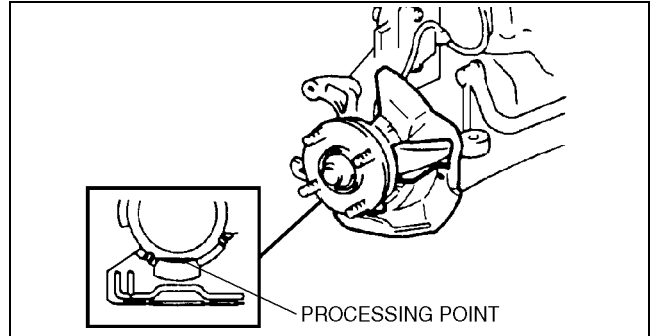

A3U0311W002

3. Tighten the hub nut while holding the wheel hub using a brass bar.

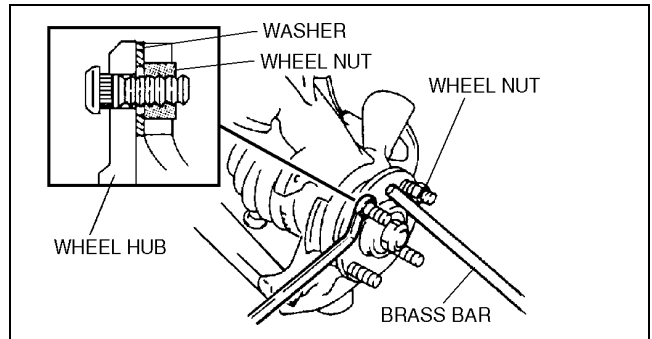

A3U0311W003

# FRONT AXLE

## WHEEL HUB, STEERING KNUCKLE REMOVAL/INSTALLATION

A3U03110400W04

### Caution

- Performing the following procedures without first removing the ABS wheel-speed sensor may possibly cause an open circuit in the harness if it is pulled by mistake. Before performing the following procedures, remove the ABS wheel-speed sensor (axle side) and fix it to an appropriate place where the sensor will not be pulled by mistake while servicing the vehicle.

- Remove in the order indicated in the table.
- Install in the reverse order of removal.
- After installation, inspect the front wheel alignment. (See 02-11-1 FRONT WHEEL ALIGNMENT.)

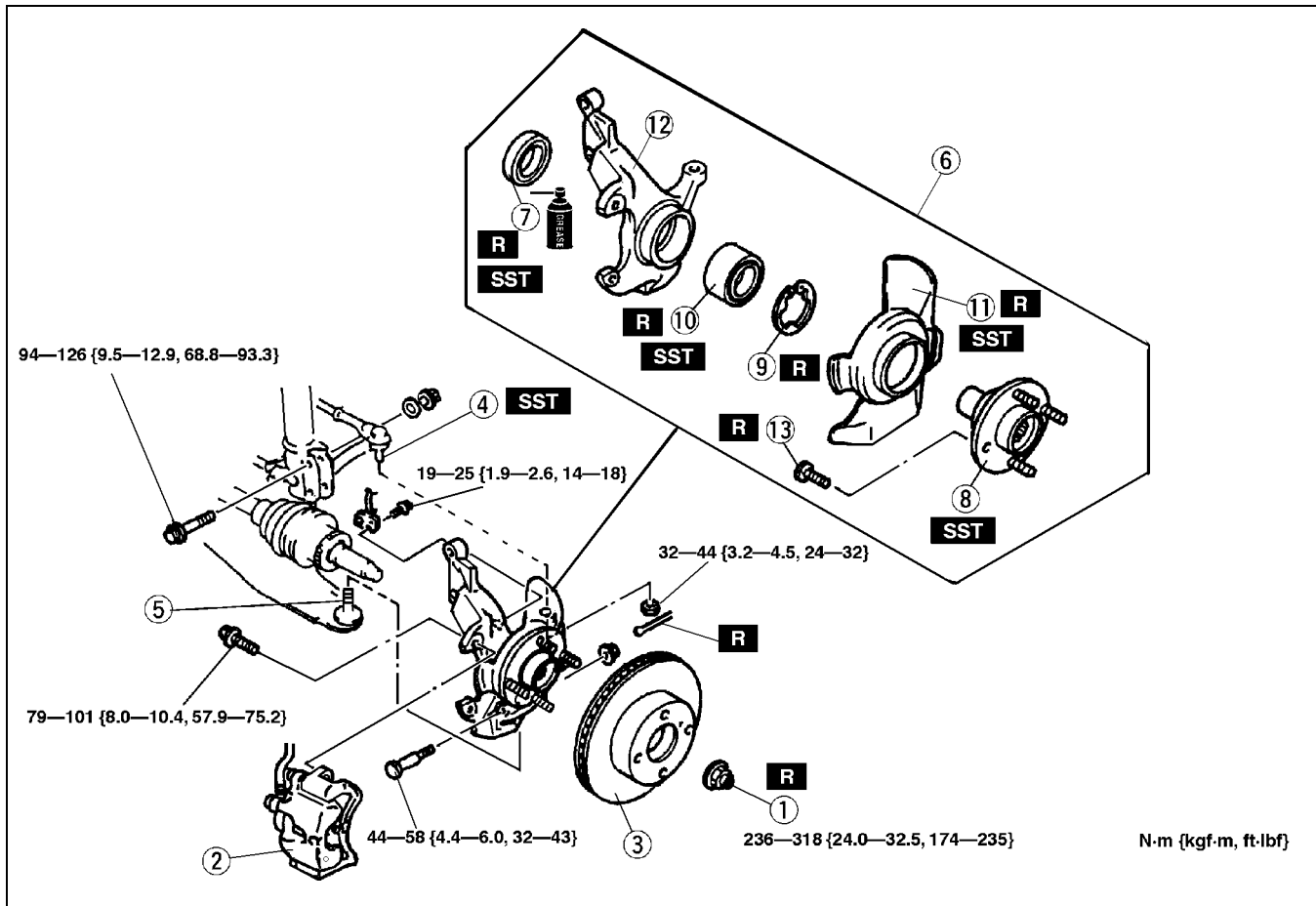

A3U0311W001

1	Locknut (See 03-11-4 Locknut Removal Note) (See 03-11-7 Locknut Installation Note)
2	Brake caliper component
3	Disc plate
4	Tie-rod end (See 06-12-10 Tie-rod End Ball Joint Removal Note)
5	Lower arm ball joint
6	Wheel hub, steering knuckle, dust cover
7	Oil seal (See 03-11-7 Oil Seal Installation Note)
8	Wheel hub component (See 03-11-4 Wheel Hub Component Removal Note) (See 03-11-6 Wheel Hub Component Installation Note)

9	Retaining ring
10	Wheel bearing (See 03-11-4 Wheel Bearing Removal Note) (See 03-11-6 Wheel Bearing Installation Note)
11	Dust cover (See 03-11-5 Dust Cover Removal Note) (See 03-11-6 Dust Cover Installation Note)
12	Steering knuckle
13	Hub bolt (See 03-11-5 Hub Bolt Removal Note) (See 03-11-5 Hub Bolt Installation Note)

03-11

## FRONT AXLE

### Locknut Removal Note

1. Knock the crimped portion of the locknut outward using a small chisel and a hammer.
2. Lock the hub by applying the brakes.
3. Remove the locknut.

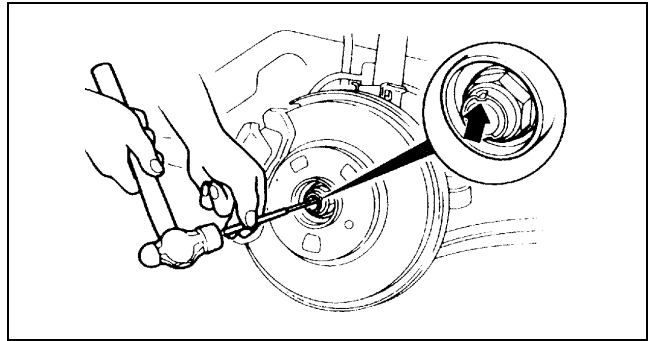

X3U311WA5

### Wheel Hub Component Removal Note

1. Remove the wheel hub component using the SSTs.

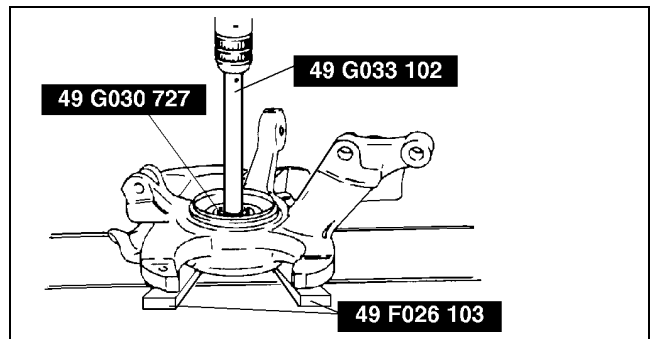

A3U0311W008

2. If the bearing inner race remains on the front wheel hub component, grind a section of the bearing inner race until **approx. 0.5 mm {0.020 in}** remains. Then remove it using a chisel.

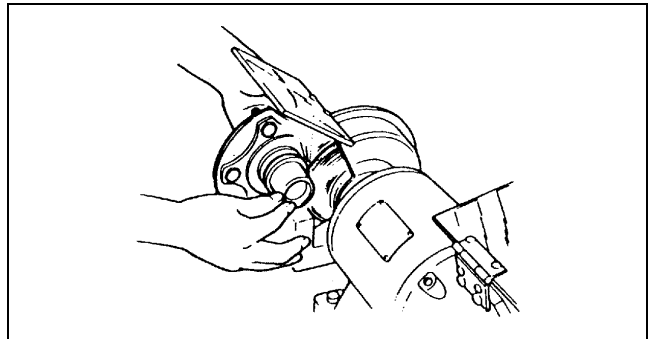

X3U311WA7

### Wheel Bearing Removal Note

1. Remove the wheel bearing using the SSTs.

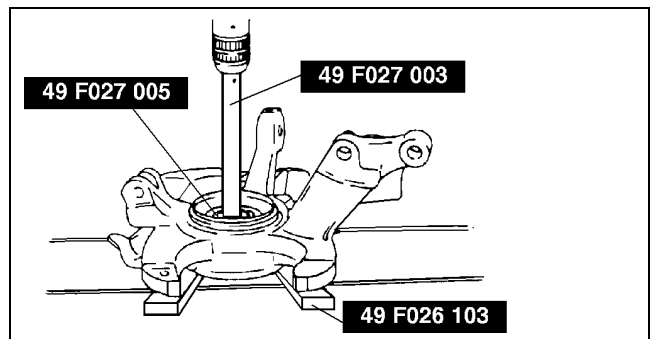

A3U0311W009

# FRONT AXLE

## Dust Cover Removal Note

### Note

- The dust cover does not need to be removed unless it is being replaced.

1. Mark the dust cover and steering knuckle for proper installation.

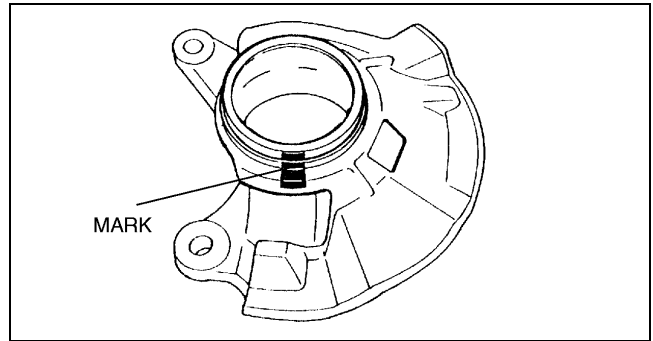

Y3U311WA1

03-11

2. Remove the dust cover using a chisel.

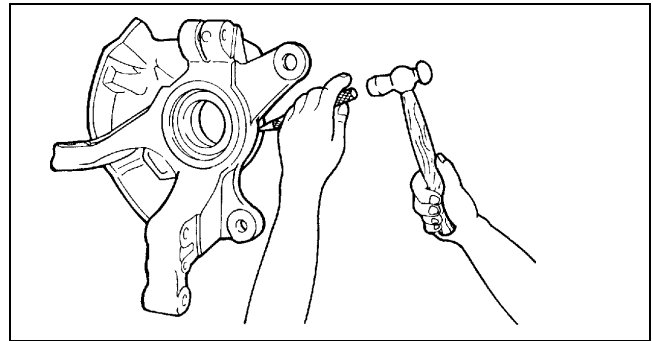

X3U311WAA

## Hub Bolt Removal Note

### Note

- The hub bolts do not need to be removed unless they are being replaced.

1. Remove the hub bolts using a press.

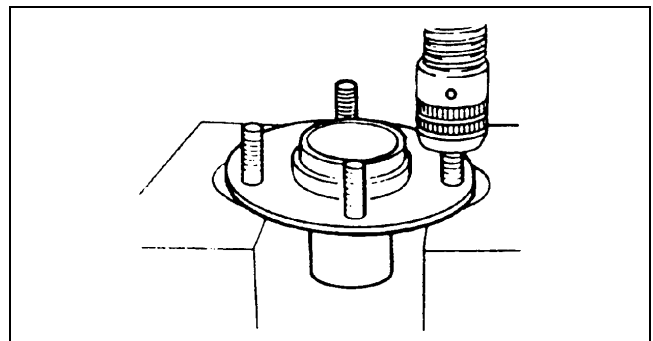

X3U311WAB

## Hub Bolt Installation Note

1. Install the new hub bolts using a press.

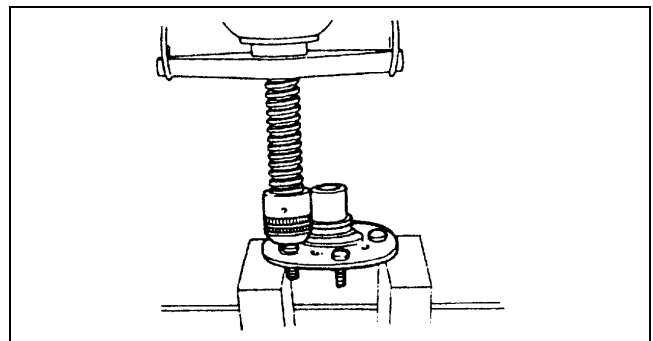

X3U311WAC

## FRONT AXLE

### Dust Cover Installation Note

1. Mark the new dust cover in the same way as the removed one.
2. Align the marks of the new dust cover and the knuckle.

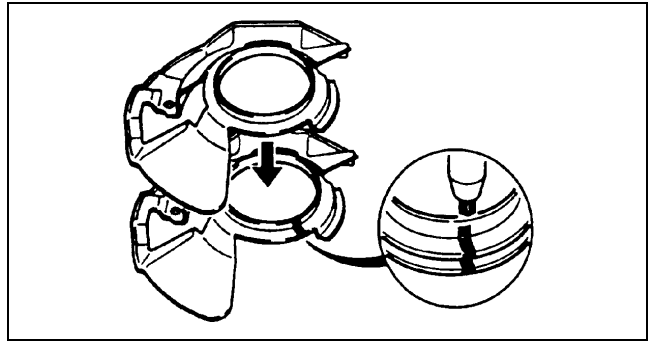

X3U311WAD

3. Install the new dust cover using the SSTs.

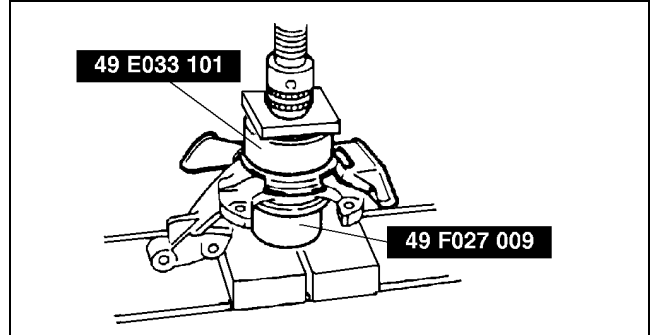

A3U0311W004

### Wheel Bearing Installation Note

1. Install the new wheel bearing using the SSTs.

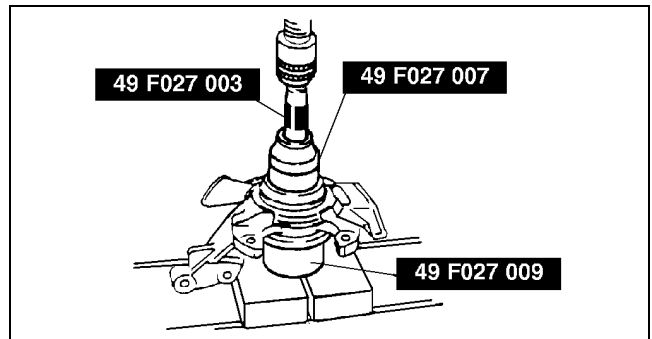

A3U0311W005

### Wheel Hub Component Installation Note

1. Install the wheel hub component using the SST.

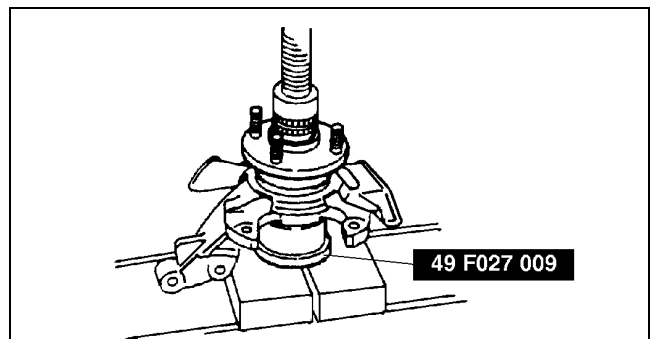

A3U0311W006

## FRONT AXLE

### Oil Seal Installation Note

1. Apply grease to the new oil seal lip.
2. Install the new oil seal flush with the knuckle using the **SST**.

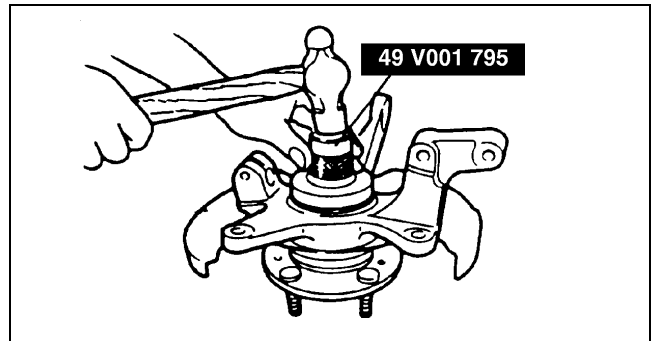

X3U31WAH

03-11

### Locknut Installation Note

1. Install a new locknut and stake it as shown.

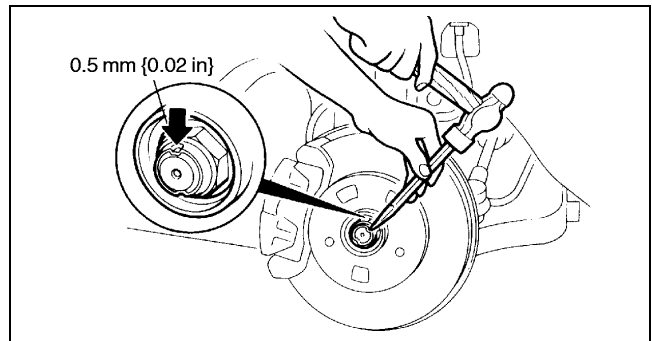

X3U31WAJ

# 03-12 REAR AXLE

REAR AXLE LOCATION INDEX..... 03-12-1  
**WHEEL HUB, HUB SPINDLE**  
 PRE-INSPECTION ..... 03-12-1  
 Wheel Bearing Play Inspection ..... 03-12-1  
**WHEEL HUB, HUB SPINDLE (DRUM BRAKE TYPE)**  
 REMOVAL/INSTALLATION ..... 03-12-2  
 Locknut Removal Note..... 03-12-3  
 ABS Sensor Rotor (With ABS)  
 Removal Note ..... 03-12-3

ABS Sensor Rotor (With ABS)  
 Installation Note .....03-12-3  
 Locknut Installation Note .....03-12-4  
**WHEEL HUB, HUB SPINDLE (DISC BRAKE TYPE)**  
 REMOVAL/INSTALLATION.....03-12-4  
 ABS Sensor Rotor (With ABS)  
 Installation Note .....03-12-5

## REAR AXLE LOCATION INDEX

A3U03120500W01

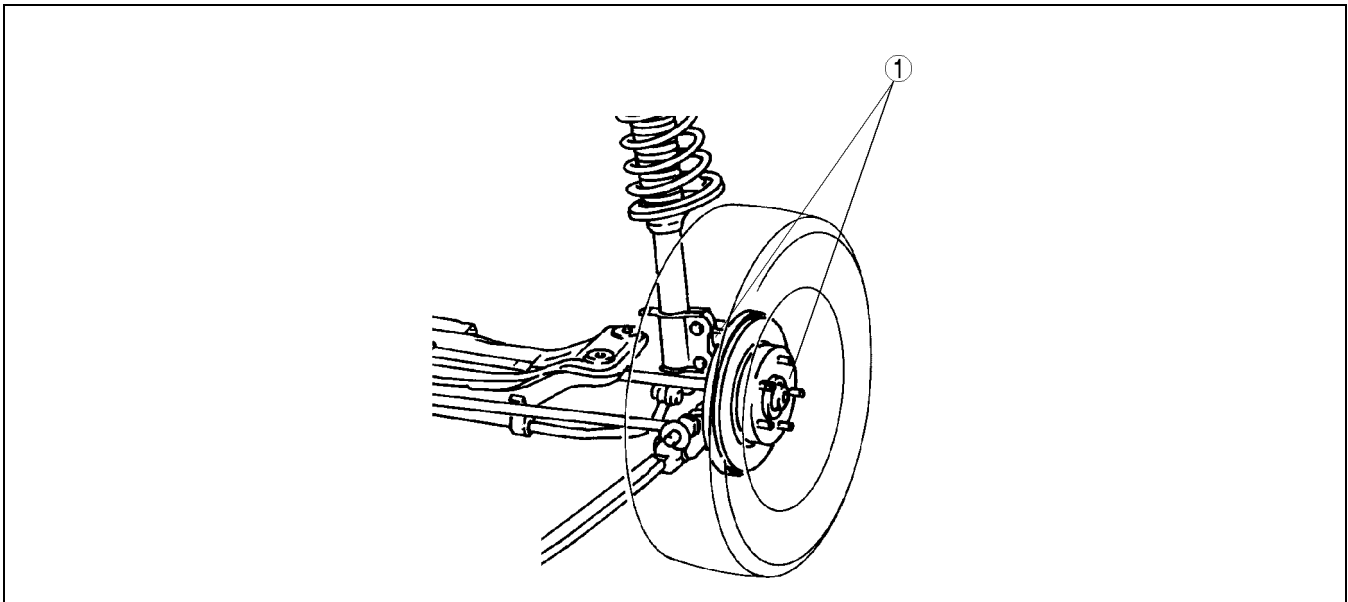

Z3U0312W005

1	Wheel hub, hub spindle (See 03-12-1 WHEEL HUB, HUB SPINDLE PRE-INSPECTION) (See 03-12-4 WHEEL HUB, HUB SPINDLE (DISC BRAKE TYPE) REMOVAL/INSTALLATION) (See 03-12-2 WHEEL HUB, HUB SPINDLE (DRUM BRAKE TYPE) REMOVAL/INSTALLATION)
---	---

## WHEEL HUB, HUB SPINDLE PRE-INSPECTION

A3U03120500W02

### Wheel Bearing Play Inspection

1. Position a dial indicator against the brake drum (brake drum type), or wheel hub (disc brake type).
2. Push and pull the rear brake component by hand in the axial direction and measure the wheel bearing play.
  - If the bearing play exceeds the specification, replace the wheel hub component as necessary and tighten the locknut to the specified torque and retest.

**Wheel bearing play**  
**0.05 mm {0.002 in}**

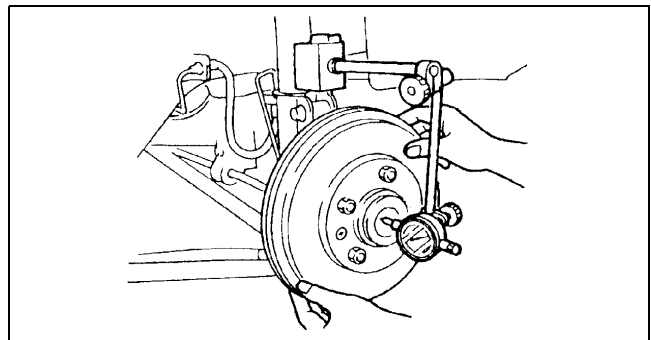

X3U312WA0



# REAR AXLE

## WHEEL HUB, HUB SPINDLE (DRUM BRAKE TYPE) REMOVAL/INSTALLATION

A3U031205000W03

### Caution

- Performing the following procedures without first removing the ABS wheel-speed sensor may possibly cause an open circuit in the harness if it is pulled by mistake. Before performing the following procedures, remove the ABS wheel-speed sensor (axle side) and fix it to an appropriate place where the sensor will not be pulled by mistake while servicing the vehicle.

- Remove in the order indicated in the table.
- Install in the reverse order of removal.

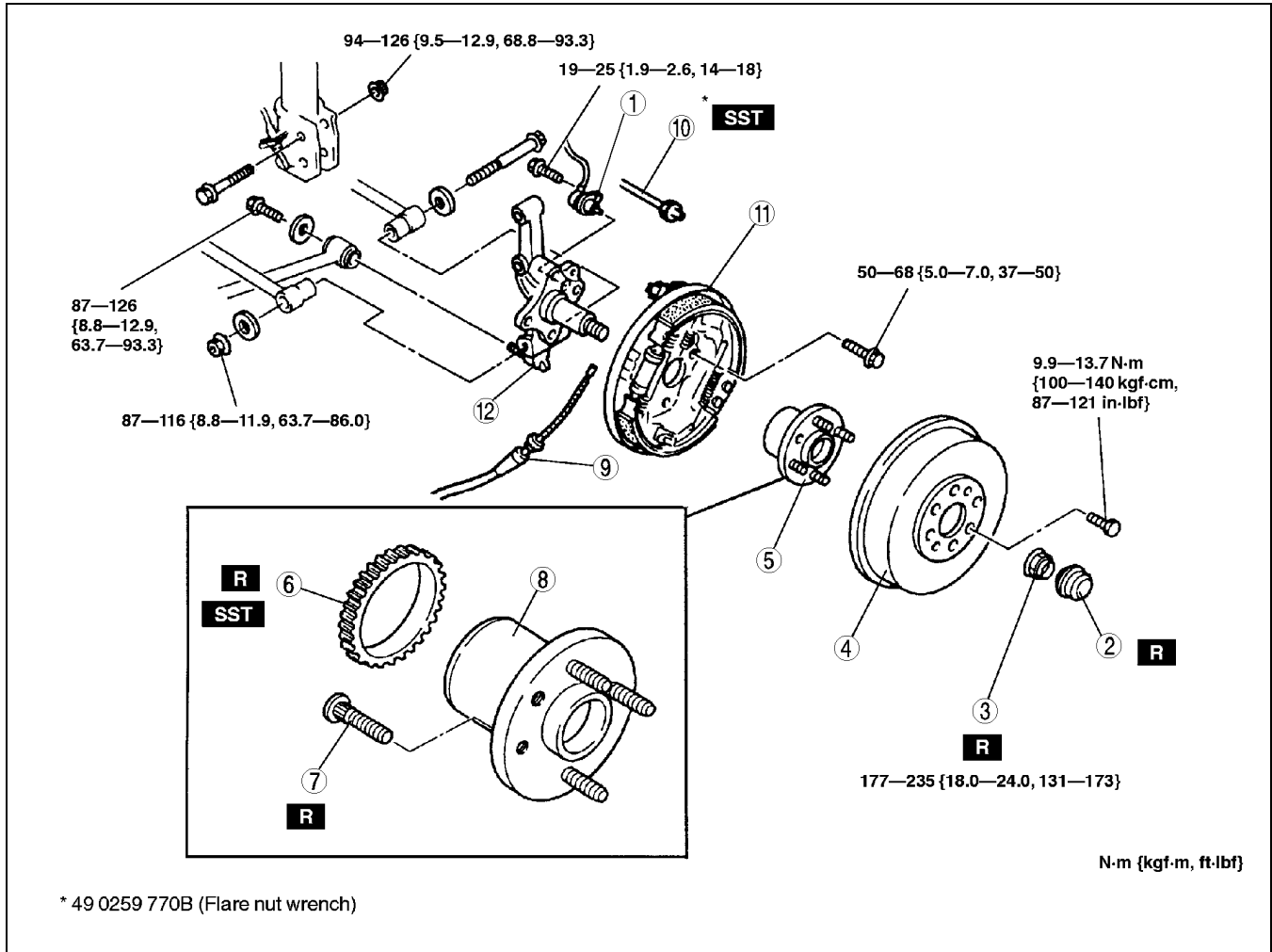

Z3U0312W001

1	ABS-wheel speed sensor
2	Hub cap
3	Locknut (See 03-12-3 Locknut Removal Note) (See 03-12-4 Locknut Installation Note)
4	Brake drum
5	Wheel hub and ABS sensor rotor (with ABS)
6	ABS sensor rotor (with ABS) (See 03-12-3 ABS Sensor Rotor (With ABS) Removal Note) (See 03-12-3 ABS Sensor Rotor (With ABS) Installation Note)

7	Hub bolt (See 03-11-5 Hub Bolt Removal Note) (See 03-11-5 Hub Bolt Installation Note)
8	Wheel hub
9	Parking brake cable
10	Brake pipe
11	Rear brake component
12	Hub spindle

## REAR AXLE

### Locknut Removal Note

1. Raise the staked portion of the locknut using a small cape chisel and a hammer.
2. Lock the hub by applying the brakes.
3. Remove the locknut.

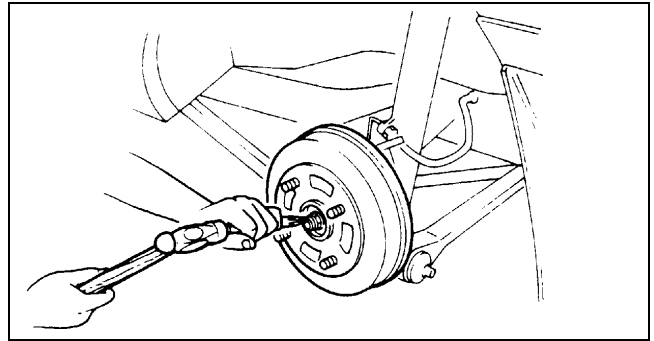

X3U312WA2

03-12

### ABS Sensor Rotor (With ABS) Removal Note

#### Note

- The sensor rotor does not need to be removed unless it is being replaced.

1. Remove the sensor rotor using a chisel.

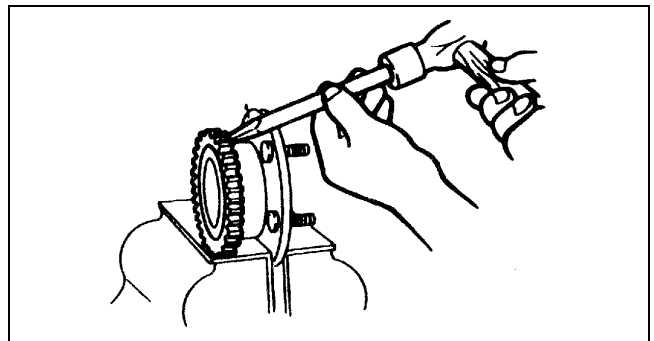

X3U312WA3

### ABS Sensor Rotor (With ABS) Installation Note

1. Set the **SST** as shown in the figure.

#### Caution

- Position the **SST** so that marking **A** faces the bottom.

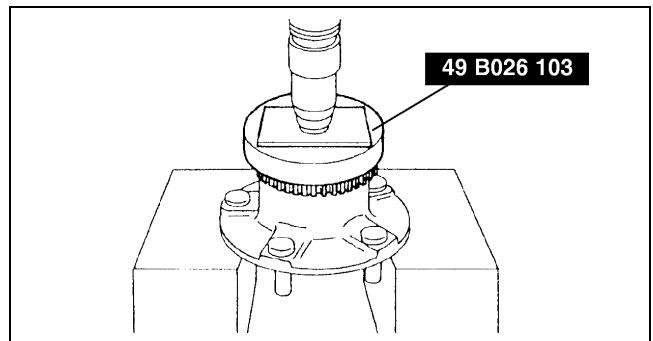

X3U312WA4

2. Press on the new sensor rotor using the **SST** and a press.

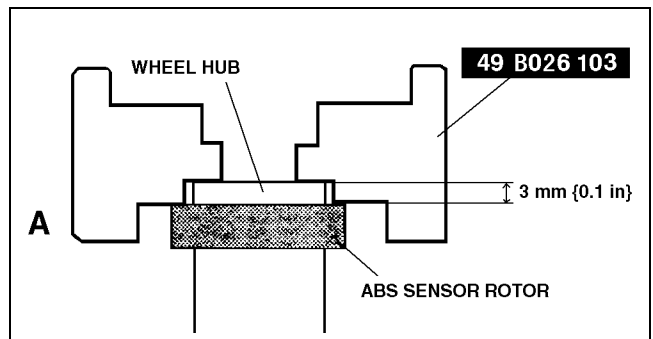

A3U0312W003

# REAR AXLE

## Locknut Installation Note

1. Install a new locknut and stake it as shown.

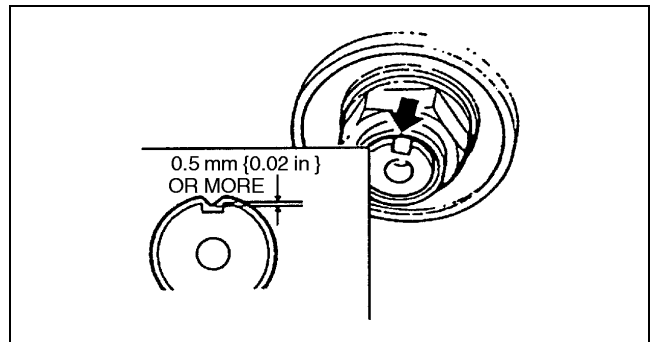

X3U312WA5

## WHEEL HUB, HUB SPINDLE (DISC BRAKE TYPE) REMOVAL/INSTALLATION

A3U031205000W04

### Caution

- Performing the following procedures without first removing the ABS wheel-speed sensor may possibly cause an open circuit in the harness if it is pulled by mistake. Before performing the following procedures, remove the ABS wheel-speed sensor (axle side) and set it to an appropriate place where the sensor will not be pulled by mistake while servicing the vehicle.

1. Remove in the order indicated in the table.
2. Install in the reverse order of removal.

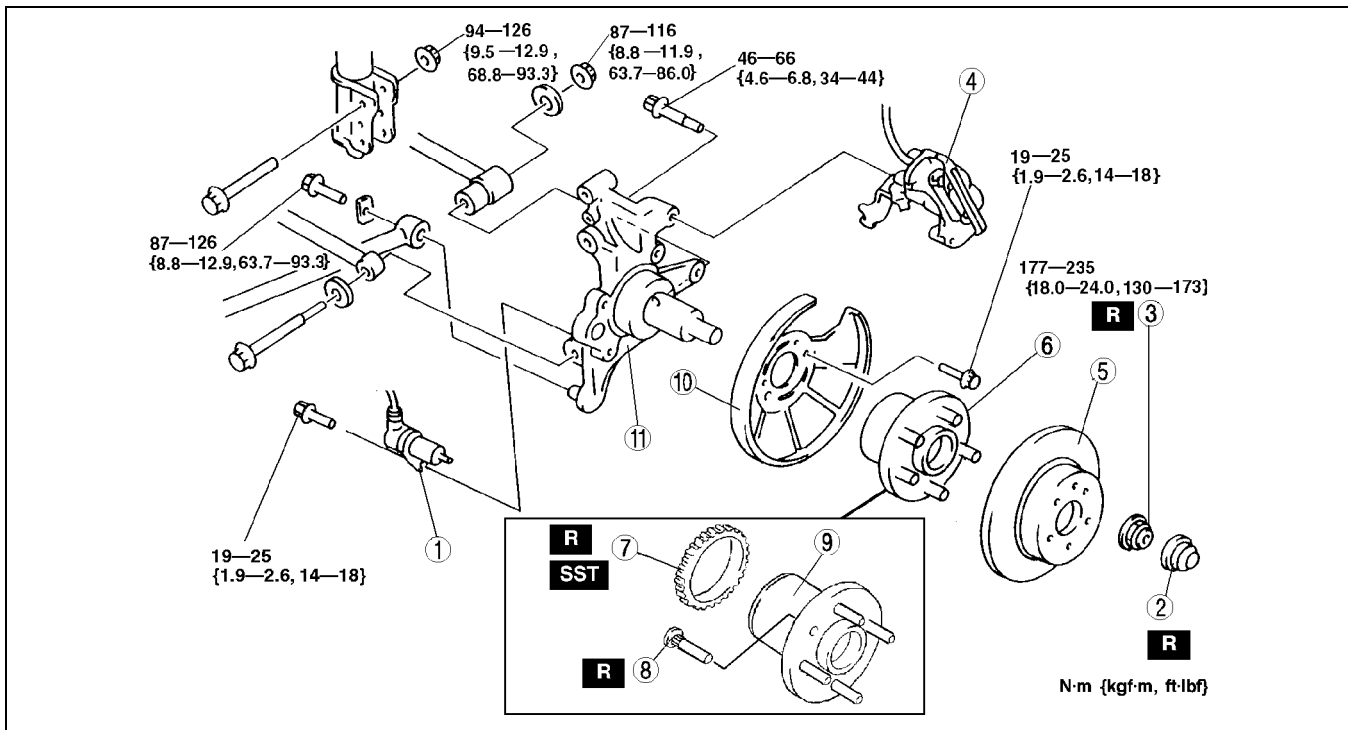

A3U0312W001

1	ABS wheel-speed sensor
2	Hub cap
3	Locknut (See 03-12-2 WHEEL HUB, HUB SPINDLE (DRUM BRAKE TYPE) REMOVAL/INSTALLATION)
4	Brake caliper component
5	Disc plate
6	Wheel hub and ABS sensor rotor

7	ABS sensor rotor (See 03-12-2 WHEEL HUB, HUB SPINDLE (DRUM BRAKE TYPE) REMOVAL/INSTALLATION) (See 03-12-5 ABS Sensor Rotor (With ABS) Installation Note)
8	Hub bolt
9	Wheel hub component
10	Dust cover
11	Hub spindle

## REAR AXLE

### ABS Sensor Rotor (With ABS) Installation Note

1. Set the **SST** as shown in the figure.

#### Caution

- Position the **SST** so that marking **B** faces the bottom.

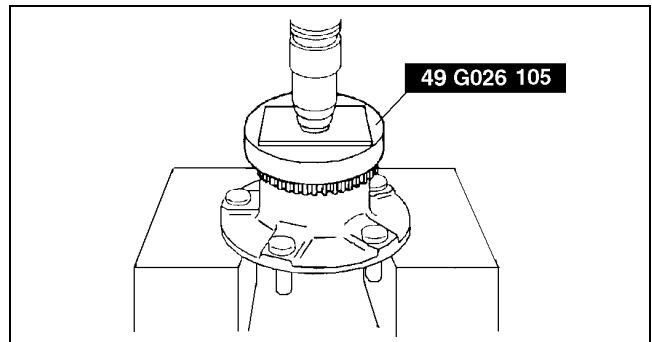

A3U0312W002

03-12

2. Press on the new sensor rotor using the **SST** and a press.

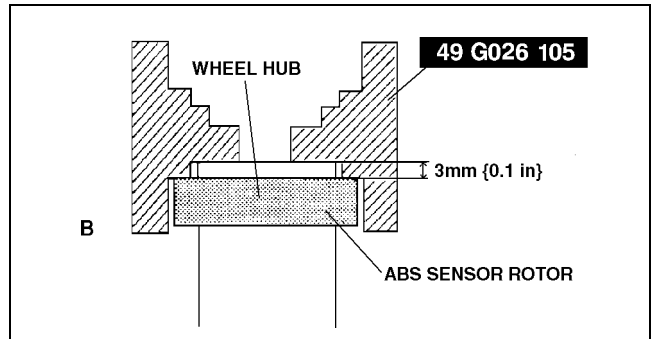

A3U0312W004

## 03-13 DRIVE SHAFT

**DRIVE SHAFT LOCATION INDEX** ..... 03-13-2

**JOINT SHAFT PRE-INSPECTION** ..... 03-13-2

**JOINT SHAFT**

**REMOVAL/INSTALLATION** ..... 03-13-3

        Right Drive Shaft and Axle

            Removal Note ..... 03-13-4

            Joint Shaft Removal Note ..... 03-13-4

            Clip Installation Note ..... 03-13-5

            Joint Shaft Installation Note ..... 03-13-5

        Right Drive Shaft and Axle

            Installation Note ..... 03-13-5

**JOINT SHAFT**

**DISASSEMBLY/ASSEMBLY** ..... 03-13-6

            Joint Shaft Disassembly Note ..... 03-13-6

            Bearing Disassembly Note ..... 03-13-6

            Dust Seal (right) Assembly Note ..... 03-13-7

            Bearing Assembly Note ..... 03-13-7

            Dust Seal (left) Assembly Note ..... 03-13-7

            Joint Shaft Assembly Note ..... 03-13-8

**DRIVE SHAFT PRE-INSPECTION** ..... 03-13-8

**DRIVE SHAFT**

**REMOVAL/INSTALLATION** ..... 03-13-9

            Drive Shaft Removal Note ..... 03-13-9

            Drive Shaft Installation Note ..... 03-13-11

**DRIVE SHAFT**

**(ZM, FS ATX, FS MTX RIGHT SIDE)**

**DISASSEMBLY/ASSEMBLY** ..... 03-13-12

            Boot Band (Wheel Side)

                Disassembly Note ..... 03-13-12

    Boot Band (Transaxle Side)

        Disassembly Note ..... 03-13-13

    Outer Ring Disassembly Note ..... 03-13-13

    Tripod Joint Disassembly Note ..... 03-13-13

    Boot Disassembly Note ..... 03-13-13

    ABS Sensor Rotor (With ABS)

        Disassembly Note ..... 03-13-14

    ABS Sensor Rotor (With ABS)

        Assembly Note ..... 03-13-14

    Dynamic Damper Assembly Note ..... 03-13-14

    Boot Assembly Note ..... 03-13-14

    Tripod Joint Assembly Note ..... 03-13-15

    Outer Ring Assembly Note ..... 03-13-15

    Boot Band (Transaxle Side)

        Assembly Note ..... 03-13-16

    Boot Band (Wheel Side)

        Assembly Note ..... 03-13-16

**DRIVE SHAFT (FS MTX LEFT SIDE)**

**DISASSEMBLY/ASSEMBLY** ..... 03-13-17

            Outer Ring Disassembly Note ..... 03-13-18

            Balls, Inner Ring, Cage

                Disassembly Note ..... 03-13-18

            Dynamic Damper Assembly Note ..... 03-13-18

            Boot Assembly Note ..... 03-13-18

            Cage, Inner Ring, Balls, Snap Ring

                Assembly Note ..... 03-13-19

            Outer Ring, Clip Assembly Note ..... 03-13-19

03-13

# DRIVE SHAFT

## DRIVE SHAFT LOCATION INDEX

A3U031325500W01

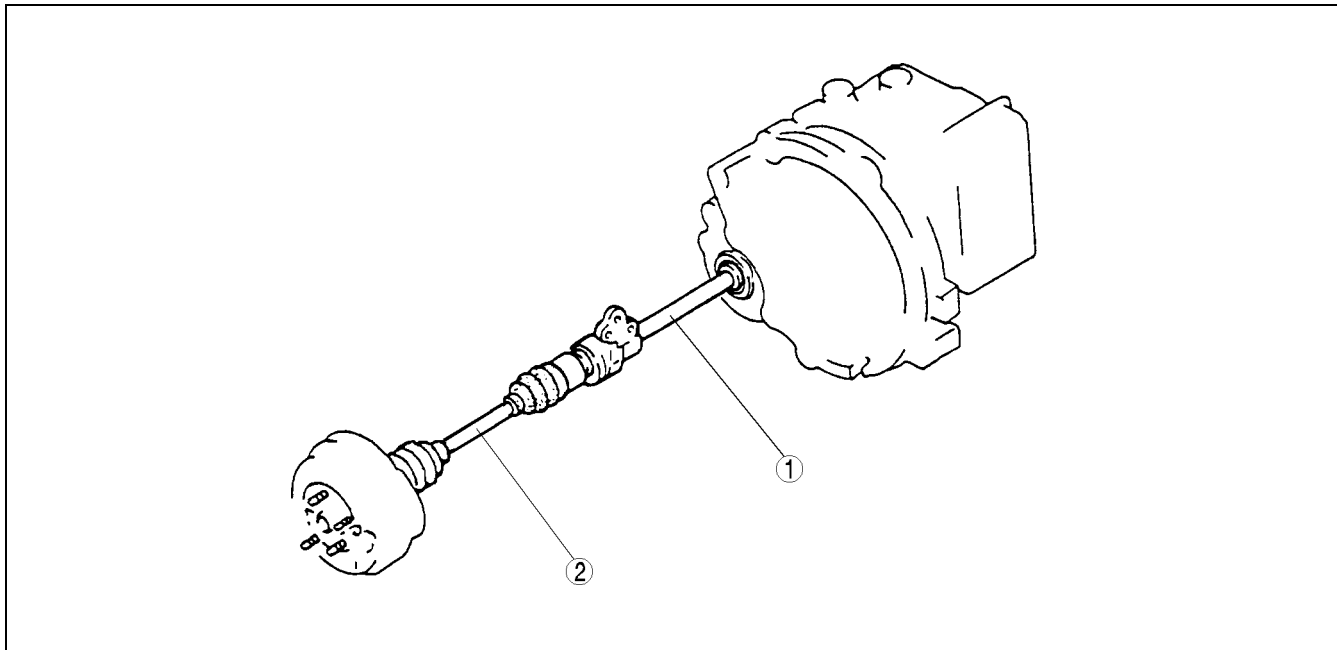

Z3U0313W007

1	Joint shaft (See 03-13-2 JOINT SHAFT PRE-INSPECTION) (See 03-13-3 JOINT SHAFT REMOVAL/ INSTALLATION) (See 03-13-6 JOINT SHAFT DISASSEMBLY/ ASSEMBLY)
---	---

2	Drive shaft (See 03-13-8 DRIVE SHAFT PRE-INSPECTION) (See 03-13-9 DRIVE SHAFT REMOVAL/ INSTALLATION) (See 03-13-12 DRIVE SHAFT (ZM, FS ATX, FS MTX RIGHT SIDE) DISASSEMBLY/ASSEMBLY) (See 03-13-17 DRIVE SHAFT (FS MTX LEFT SIDE) DISASSEMBLY/ASSEMBLY)
---	--

## JOINT SHAFT PRE-INSPECTION

A3U031325700W01

1. Verify that the joint shaft is not twisted or cracked.
  - Replace it as necessary.
2. Turn the joint shaft by hand and verify that the bearing rotates smoothly and freely.
  - Replace it as necessary.

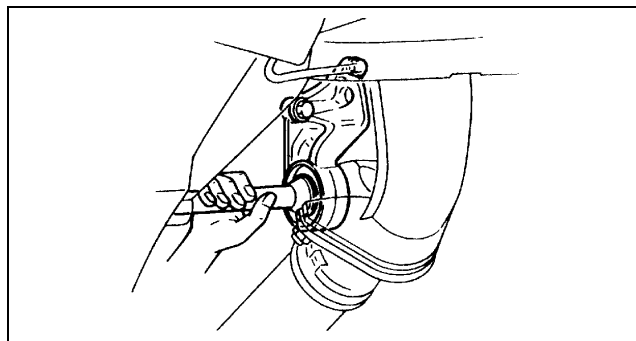

X3U313WA0

# DRIVE SHAFT

## JOINT SHAFT REMOVAL/INSTALLATION

A3U031325700W02

### Caution

- Performing the following procedures without first removing the ABS wheel-speed sensor could cause an open circuit in the harness if it is pulled by mistake. Before performing the following procedures, remove the ABS wheel-speed sensor (axle side) and fix it to an appropriate place where the sensor will not be pulled by mistake while servicing the vehicle.

1. Drain the transaxle oil.
2. Remove in the order indicated in the table.
3. Install in the reverse order of removal.

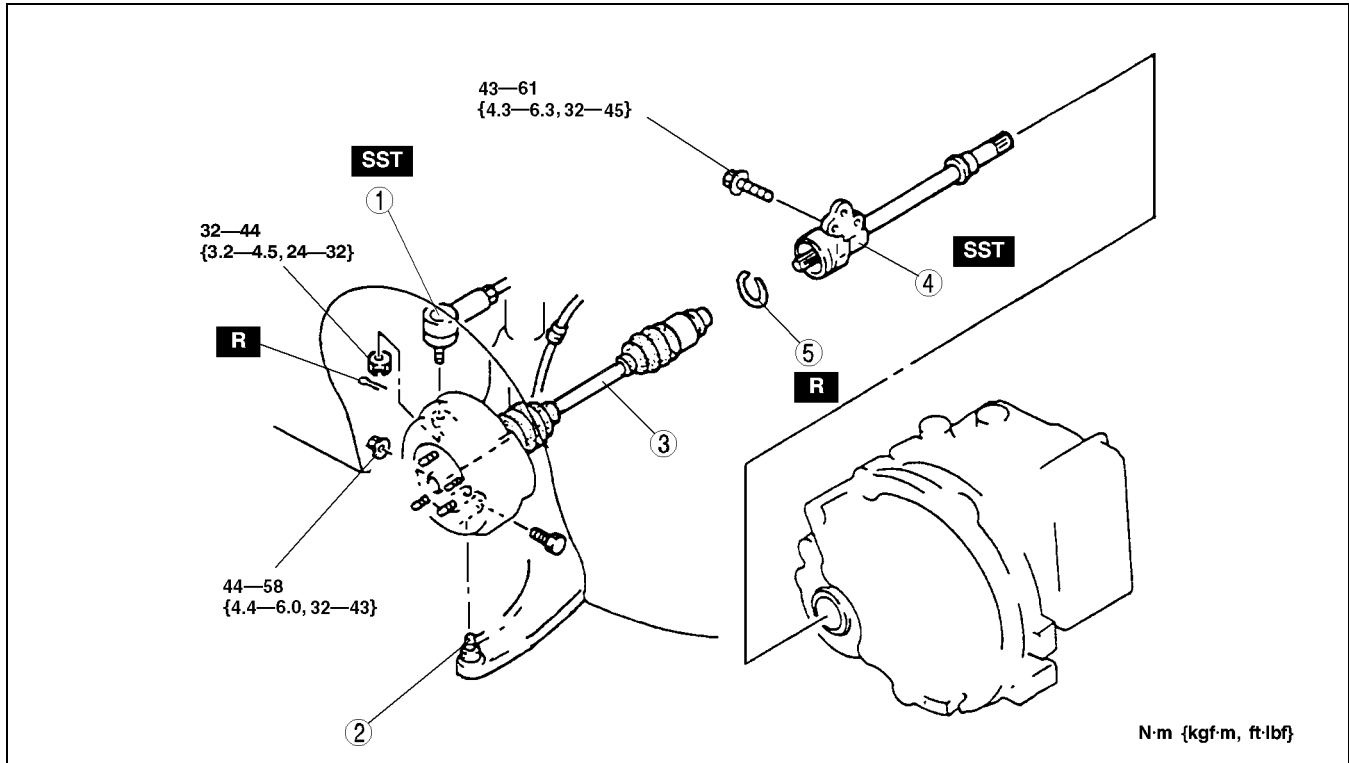

03-13

Y3E6316W001

1	Tie-rod end
2	Lower arm ball joint
3	Right drive shaft and axle (See 03-13-4 Right Drive Shaft and Axle Removal Note) (See 03-13-5 Right Drive Shaft and Axle Installation Note)

4	Joint shaft (See 03-13-4 Joint Shaft Removal Note) (See 03-13-5 Joint Shaft Installation Note)
5	Clip (See 03-13-5 Clip Installation Note)

## DRIVE SHAFT

### Right Drive Shaft and Axle Removal Note

1. Remove the clinch bolt and nut.
2. Wrap a rag around the ball joint dust boot.
3. Pry the lower arm out of the knuckle.

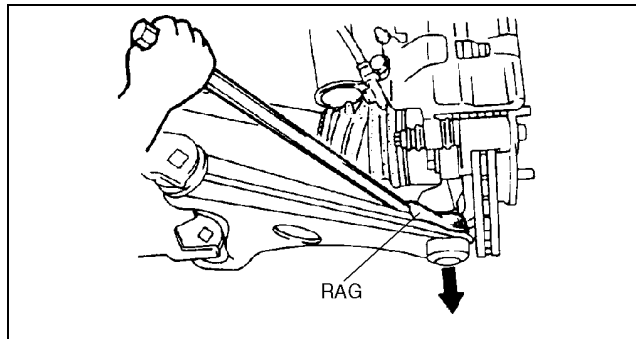

Z3U0312W003

4. As shown in the figure, insert a pry bar between the right drive shaft and the joint shaft and tap on the bar to uncouple them.

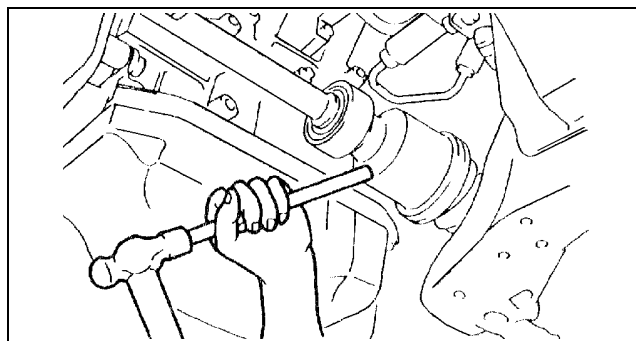

Y3E6316W007

### Joint Shaft Removal Note

1. Secure the joint shaft bracket cylinder block.
2. Pull the joint shaft straight out.

#### Caution

- The sharp edges of the joint shaft can slice or puncture the oil seal. Be careful when installing the joint shaft to the transaxle.

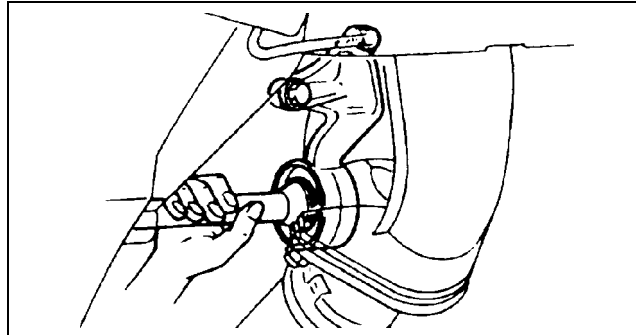

Y3E6316W008

3. Insert the **SST** into the transaxle to hold the side gears after joint shaft removed.

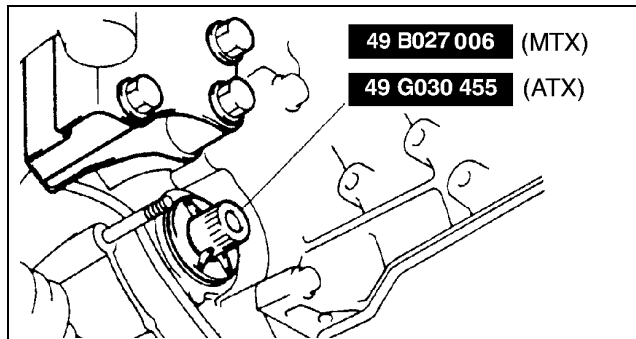

Y3E6316W009



## DRIVE SHAFT

### Clip Installation Note

1. Install a new clip onto the joint shaft with the opening facing upward. Ensure that the diameter of the clip does not exceed the specification on installation.
2. After installation, measure the outer diameter. If it exceeds the specification, repeat steps 1—2 using a new clip.

**Outer diameter specification**  
**30.0 mm {1.18 in}**

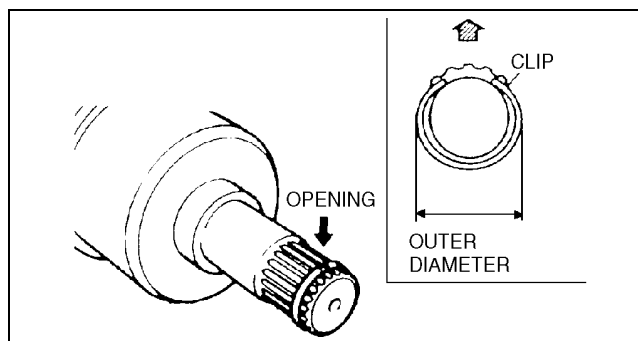

03-13

### Joint Shaft Installation Note

1. Install the joint shaft with the end gap of the new clip facing upward.
2. For FS engine, tighten the bolt A, then tighten the bolt B.

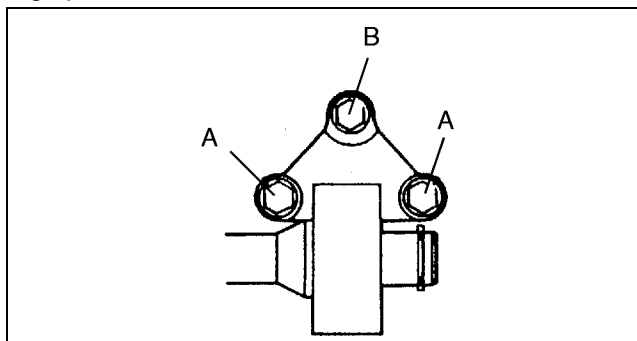

### Right Drive Shaft and Axle Installation Note

1. Push the drive shaft into the joint shaft.
2. After installation, pull the transaxle side outer ring forward to verify that the drive shaft is securely held by the clip.
3. Set the lower arm with steering knuckle, then tighten the bolt and nut.

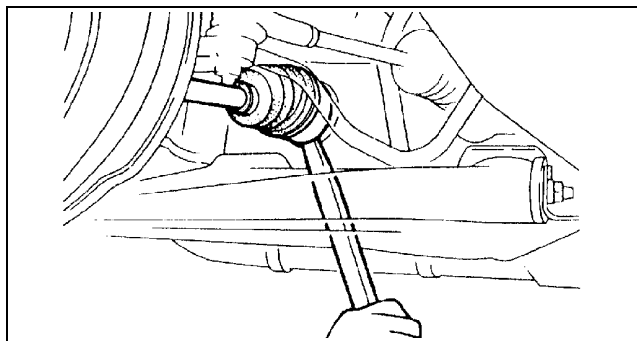

# DRIVE SHAFT

## JOINT SHAFT DISASSEMBLY/ASSEMBLY

A3U031325700W03

1. Disassemble in the order indicated in the table.
2. Assemble in the reverse order of removal.

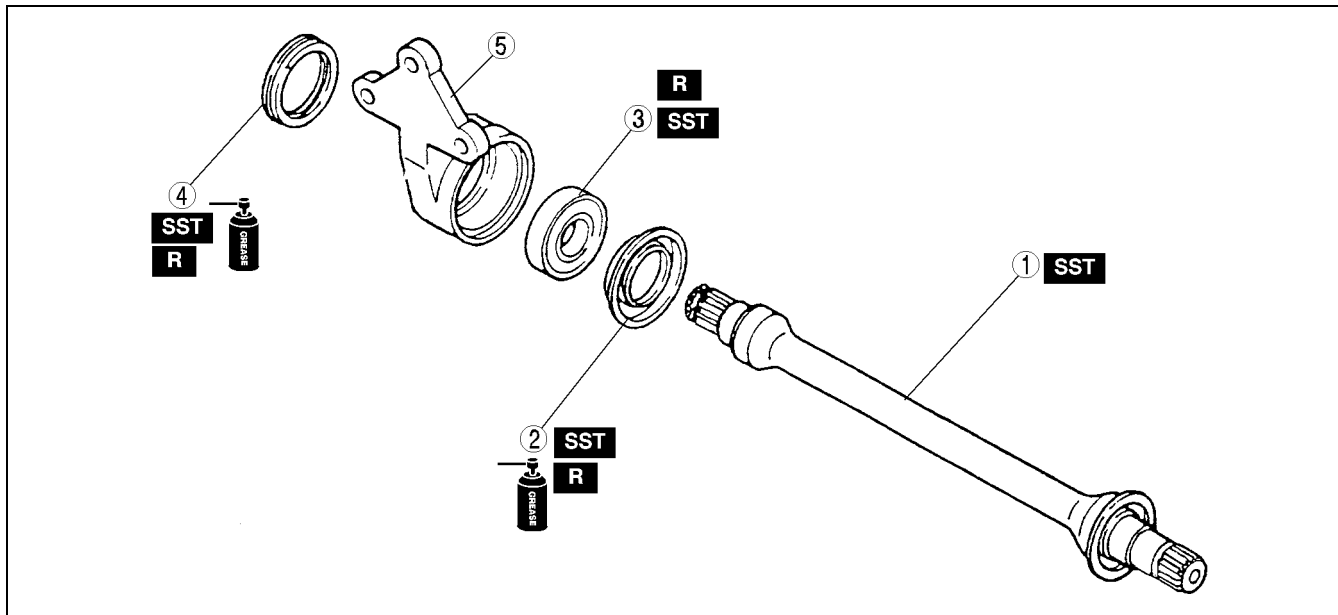

Y3E6316W002

1	Joint shaft (See 03-13-6 Joint Shaft Disassembly Note) (See 03-13-8 Joint Shaft Assembly Note)
2	Dust Seal (left) (See 03-13-7 Dust Seal (left) Assembly Note)

3	Bearing (See 03-13-6 Bearing Disassembly Note) (See 03-13-7 Bearing Assembly Note)
4	Dust Seal (right) (See 03-13-7 Dust Seal (right) Assembly Note)
5	Bracket

### Joint Shaft Disassembly Note

1. Disassemble the joint shaft using the **SST**.

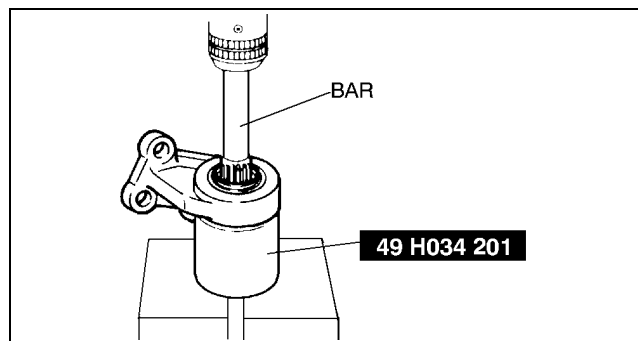

A3U0313W002

### Bearing Disassembly Note (If the bearing remains on the bracket)

1. Remove the bearing using the **SST**.

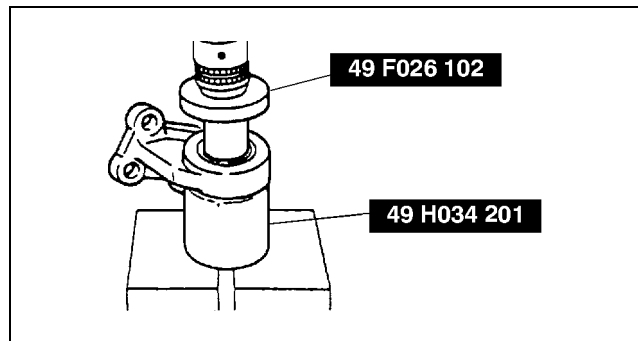

Y3E6316W014

## DRIVE SHAFT

### (If the bearing remains on the joint shaft)

1. While holding the joint shaft, press out the bearing using the **SST**.

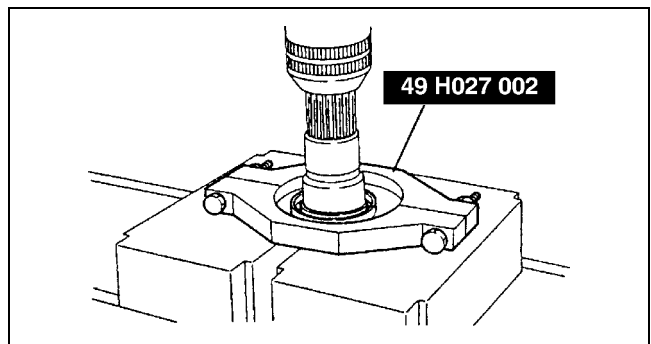

Y3E6316W015

03-13

### Dust Seal (right) Assembly Note

1. Apply grease to a new dust seal lip.
2. Install the new right side dust seal using the **SSTs**.

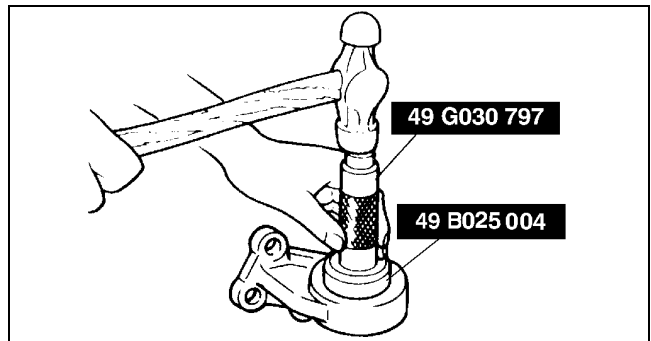

Y3E6316W016

### Bearing Assembly Note

1. Install the new bearing using the **SSTs**.

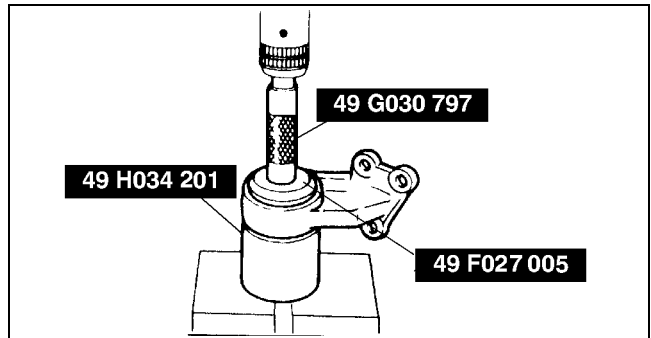

Y3E6316W017

### Dust Seal (left) Assembly Note

1. Apply grease to a new dust seal lip.
2. Install the new left side dust seal using a steel plate and the **SSTs**.

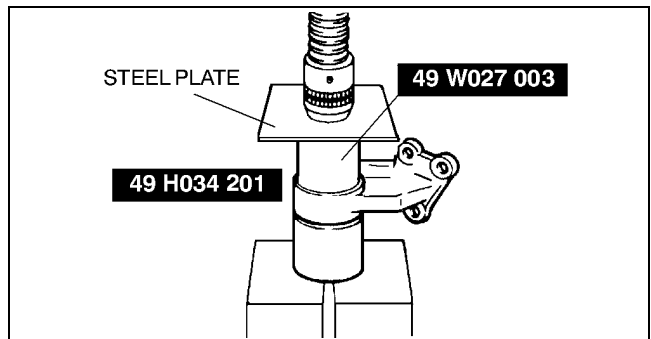

A3U0313W003

## DRIVE SHAFT

### Joint Shaft Assembly Note

1. Assemble the joint shaft using a press and the **SSTs**

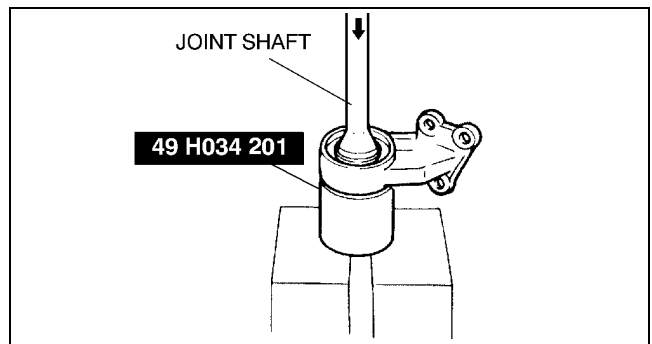

Y3E6316W019

### DRIVE SHAFT PRE-INSPECTION

1. Inspect the dust boot on the drive shaft for cracks, damage, leaking grease, and looseness in the boot band.
2. Inspect the drive shaft for bends, cracks, and wear in the joint or splines.
  - Repair or replace the drive shaft or boot/band as necessary.

A3U031325500W02

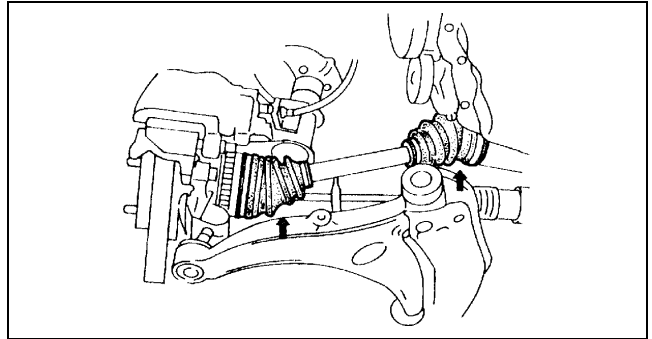

X3U313WAH

# DRIVE SHAFT

## DRIVE SHAFT REMOVAL/INSTALLATION

A3U03132550W03

### Caution

- Performing the following procedures without first removing the ABS wheel-speed sensor may possibly cause an open circuit in the harness if it is pulled by mistake. Before performing the following procedures, remove the ABS wheel-speed sensor (axle side) and fix it to an appropriate place where the sensor will not be pulled by mistake while servicing the vehicle.

1. Drain the transaxle oil.
2. Remove the splash shield.
3. Remove in the order indicated in the table.
4. Install in the reverse order of removal.

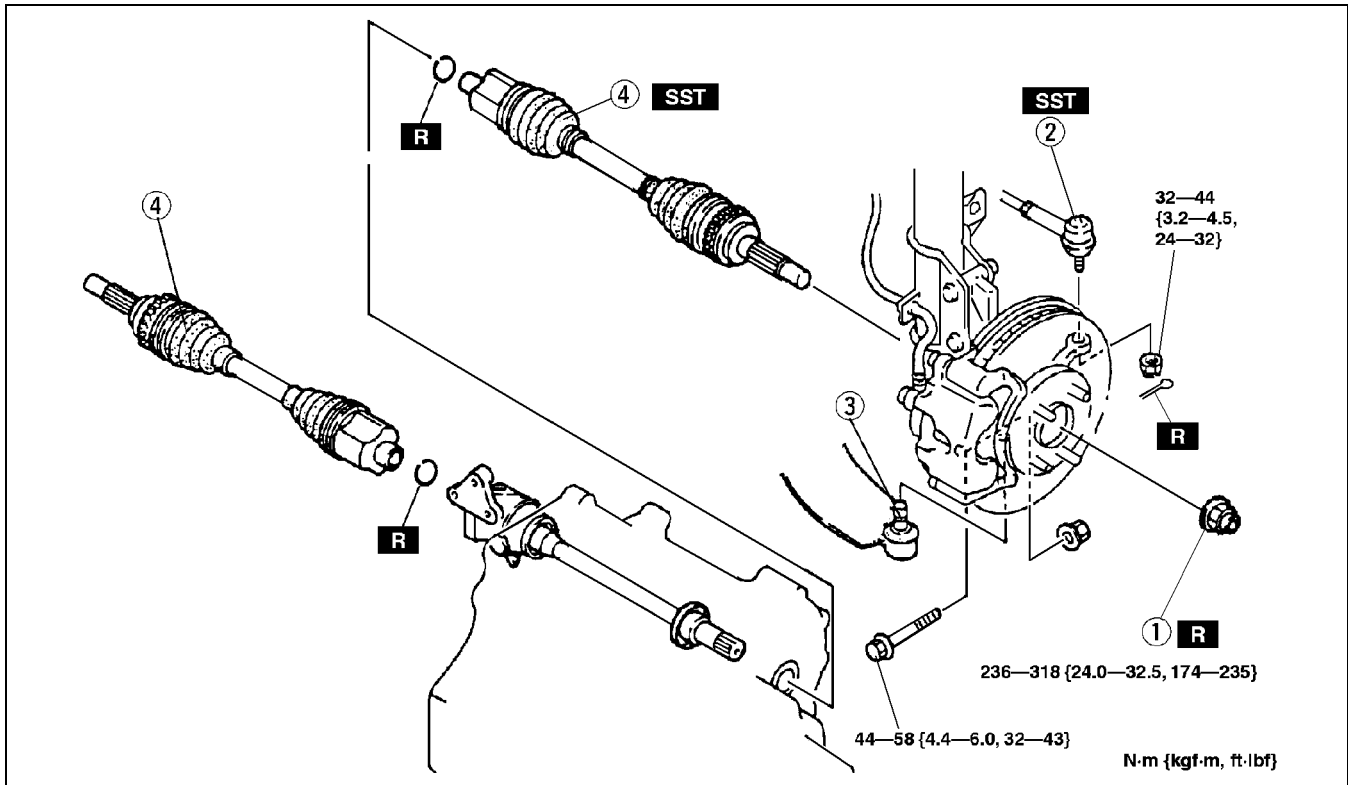

A3U0313W001

1	Locknut
2	Tie-rod end
3	Lower arm ball joint

4	Drive shaft (See 03-13-9 Drive Shaft Removal Note) (See 03-13-11 Drive Shaft Installation Note)
---	---

### Drive Shaft Removal Note

1. Remove the clinch bolt and nut.
2. Wrap a rag around the ball joint dust boot.
3. Pry the lower arm out of the knuckle.
4. Install a spare nut onto the drive shaft so that the nut is flush with the end of the drive shaft.
5. Tap the nut with a copper hammer to loosen the drive shaft from the front wheel hub.

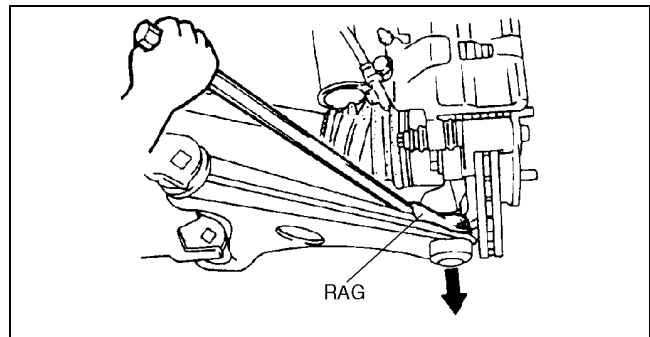

Z3U0312W003

03-13

## DRIVE SHAFT

6. Separate the drive shaft from the wheel hub.

### Caution

- The sharp edges of the drive shaft can slice or puncture the oil seal. Be careful when removing the drive shaft from the transaxle.

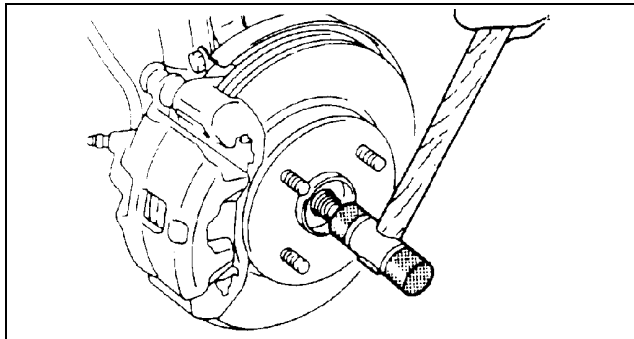

Y3E6316W020

7. Separate the left side drive shaft from the transaxle by prying with a bar inserted between the outer ring and the transaxle, as shown in the figure.

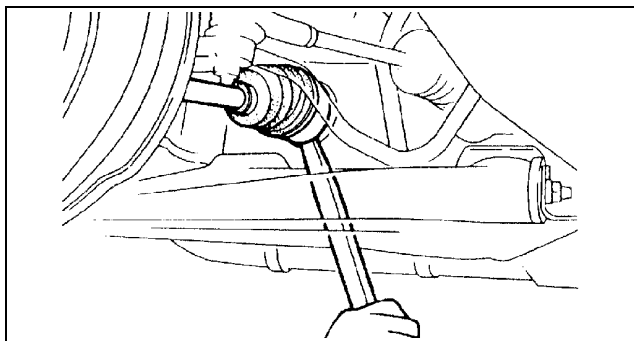

Y3E6316W021

8. Separate the right side drive shaft from the joint shaft by hammering on a bar inserted between them.

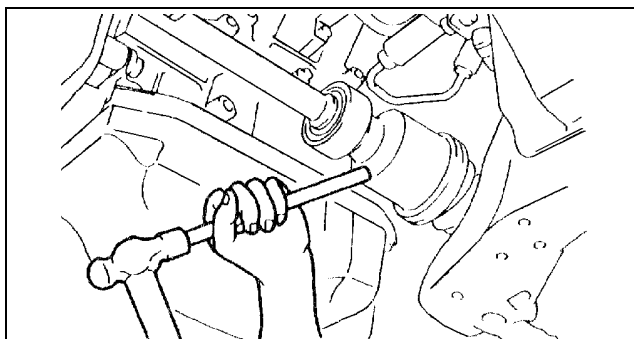

Y3E6316W007

9. Install the **SST** into the transaxle to hold the side gears after drive shaft is removed.

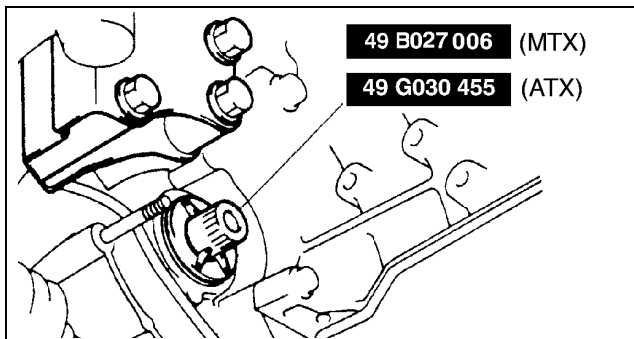

Y3E6316W009

# DRIVE SHAFT

## Drive Shaft Installation Note

### (Left side)

1. Install a new clip onto the drive shaft with the opening facing upward. Ensure that the diameter of the clip does not exceed the specification on installation.
2. After installation, measure the outer diameter.
  - If it exceeds the specification, repeat Steps 1—2 using a new clip.

### Outer diameter specification

mm {in}

Engine	Outer diameter
ZM (MTX)	27.2 {1.03}
ZM (ATX)	29.2 {1.15}
FS (MTX)	30.5 {1.20}
FS (ATX)	29.2 {1.15}

### Caution

- The sharp edges of the drive shaft can slice or puncture the oil seal. Be careful when installing the drive shaft to the transaxle.
- The oil seals are damaged easily if this procedure is not done correctly.

3. Insert the drive shaft into the wheel hub.
4. Apply ATF to the oil seal lip.

5. Push the drive shaft into the transaxle.
6. After installation, pull the transaxle side outer ring forward to confirm that the drive shaft is securely held by the clip.

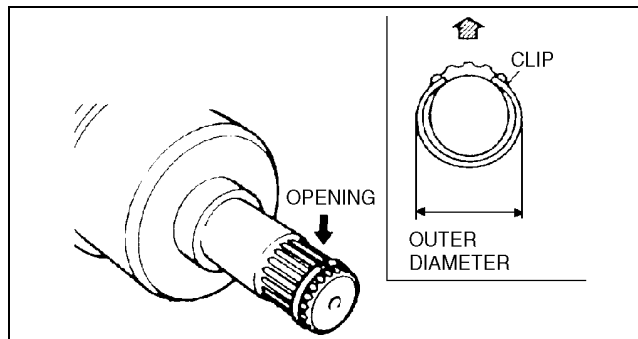

Z3U0312W004

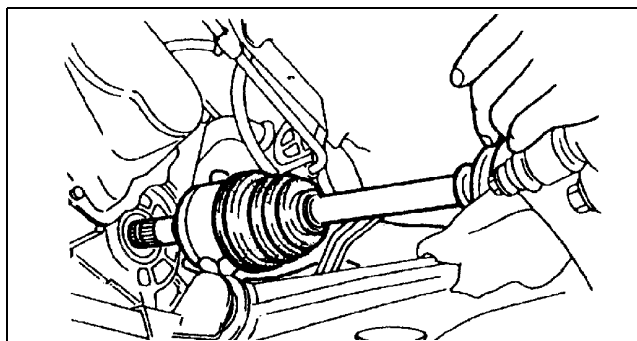

Y3E6316W023

### (Right side)

1. Install the joint shaft with the end-gap of a new clip facing upward.
2. Install the drive shaft into the wheel hub.
3. Push the drive shaft into the joint shaft.
4. After installation, pull the transaxle side outer ring forward to confirm that the drive shaft is securely held by the clip.

# DRIVE SHAFT

## DRIVE SHAFT (ZM, FS ATX, FS MTX RIGHT SIDE) DISASSEMBLY/ASSEMBLY

A3U031325500W04

1. Disassemble in the order indicated in the table.
2. Assemble in the reverse order of disassembly.

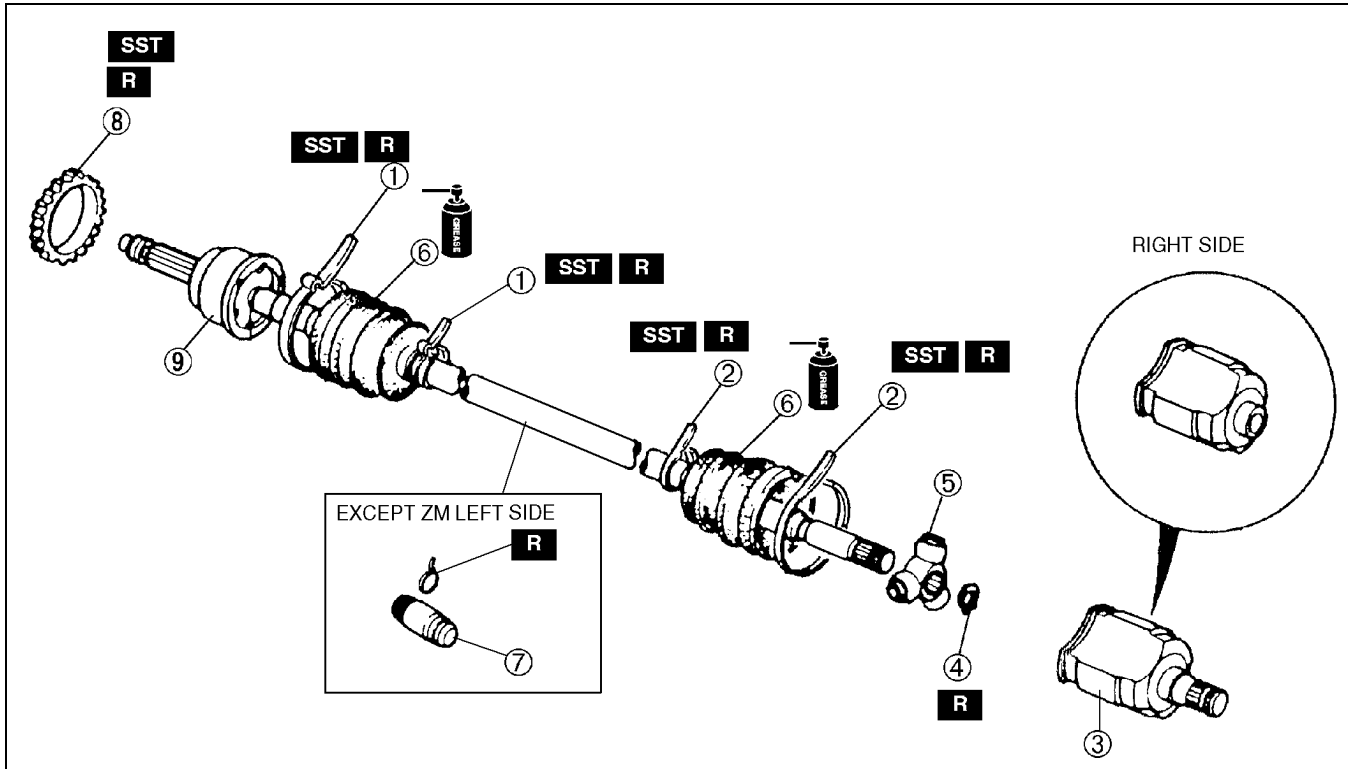

A3U0313W004

1	Boot band (wheel side) (See 03-13-12 Boot Band (Wheel Side) Disassembly Note) (See 03-13-16 Boot Band (Wheel Side) Assembly Note)
2	Boot band (transaxle side) (See 03-13-13 Boot Band (Transaxle Side) Disassembly Note) (See 03-13-16 Boot Band (Transaxle Side) Assembly Note)
3	Outer ring (See 03-13-13 Outer Ring Disassembly Note) (See 03-13-15 Outer Ring Assembly Note)
4	Snap ring

5	Tripod joint (See 03-13-13 Tripod Joint Disassembly Note) (See 03-13-15 Tripod Joint Assembly Note)
6	Boot (See 03-13-13 Boot Disassembly Note) (See 03-13-14 Boot Assembly Note)
7	Dynamic Damper (See 03-13-14 Dynamic Damper Assembly Note)
8	ABS sensor rotor (with ABS) (See 03-13-14 ABS Sensor Rotor (With ABS) Disassembly Note) (See 03-13-14 ABS Sensor Rotor (With ABS) Assembly Note)
9	Shaft and ball joint component

### Boot Band (Wheel Side) Disassembly Note

#### Note

- Thoot band need not to be replaced if removed.

1. Remove the boot clamp with end clamp pliers as shown and discard the clamp.

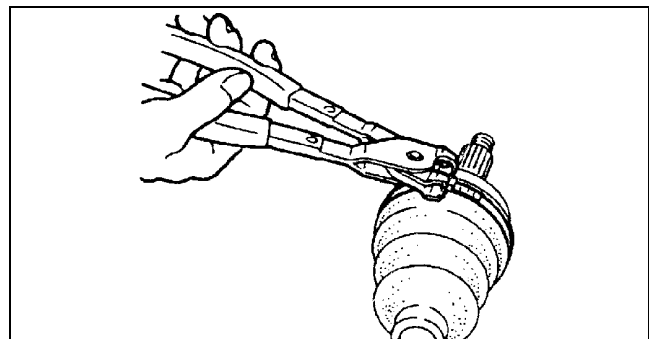

Y3E6316W025



## DRIVE SHAFT

### Boot Band (Transaxle Side) Disassembly Note

1. Pry up the locking clips using a screwdriver.
2. Pull back the end of the band.

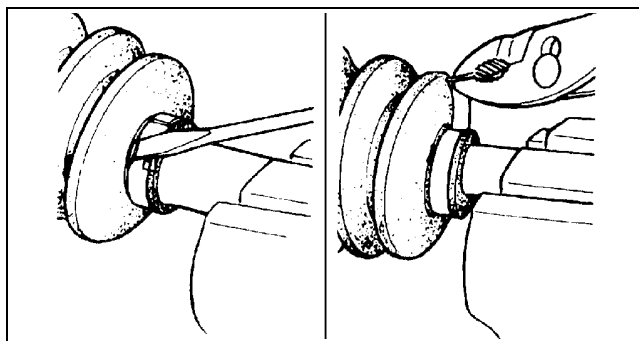

Y3E6316W031

03-13

### Outer Ring Disassembly Note

1. Mark the outer ring and the shaft for proper assembly.
2. Remove the outer ring.

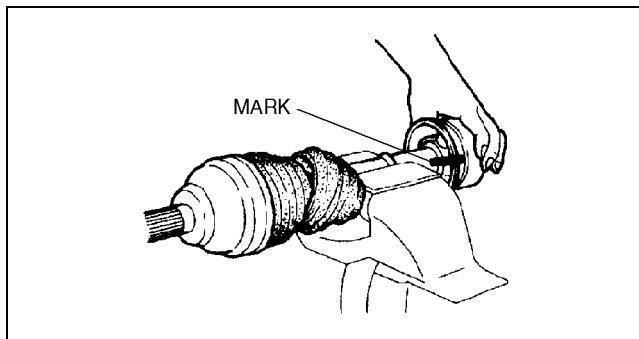

Z3U0313W002

### Tripod Joint Disassembly Note

1. Mark the shaft and tripod joint for proper assembly.
2. Remove the snap ring using snap-ring pliers.
3. Remove the tripod joint from the shaft.

#### Caution

- Do not use a hammer to remove the joint shaft.

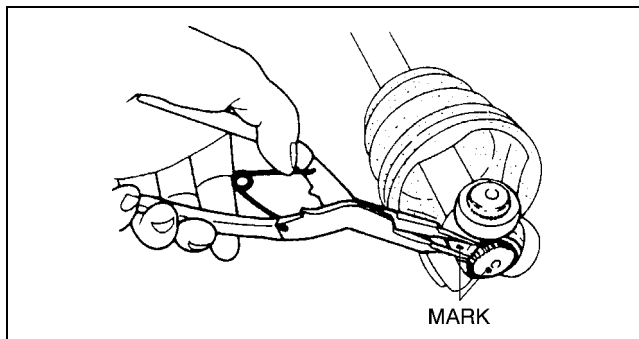

YDE6316W002

### Boot Disassembly Note

#### Note

- The wheel side boot does not need to be removed unless replacing the boot or the ball joint and shaft component.
- Do not strip the tape until the boot is assembled.

1. Wrap the shaft splines with tape.
2. Remove the boot.

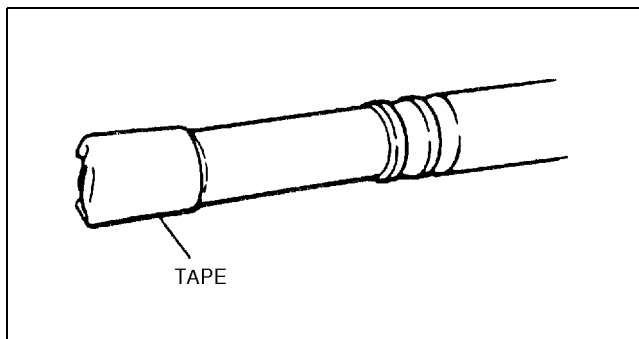

Z3U0313W003

# DRIVE SHAFT

## ABS Sensor Rotor (With ABS) Disassembly Note

### Caution

- Do not remove the sensor rotor unless it is necessary.
- Do not reuse the sensor rotor if removed.

1. Tap the ABS sensor rotor off the drive shaft using a chisel.

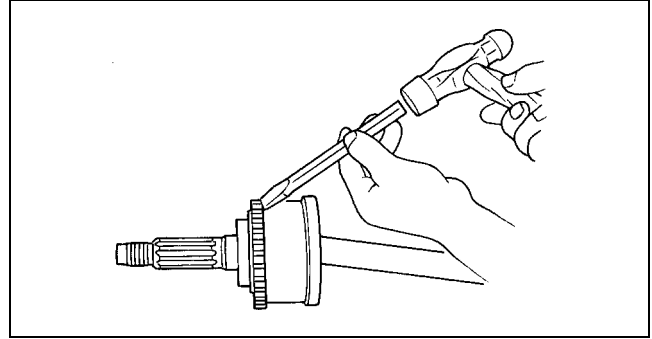

ZLU0313W105

## ABS Sensor Rotor (With ABS) Assembly Note

1. Set a new ABS sensor rotor on the drive shaft and press it on using the SSTs.

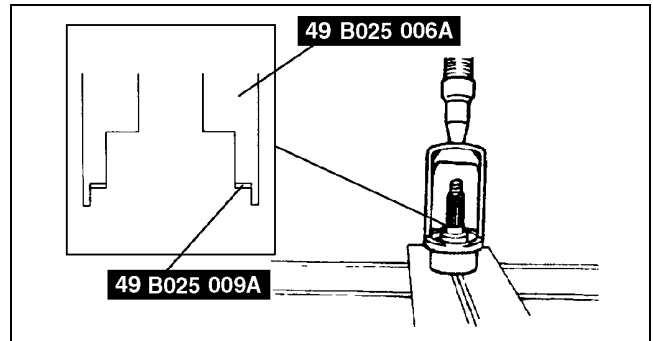

Z3U0313W004

## Dynamic Damper Assembly Note

1. Install the dynamic damper as shown in the figure.

### Standard length

292—298 mm {11.5—11.7 in}

2. Install the new boot band onto the dynamic damper.

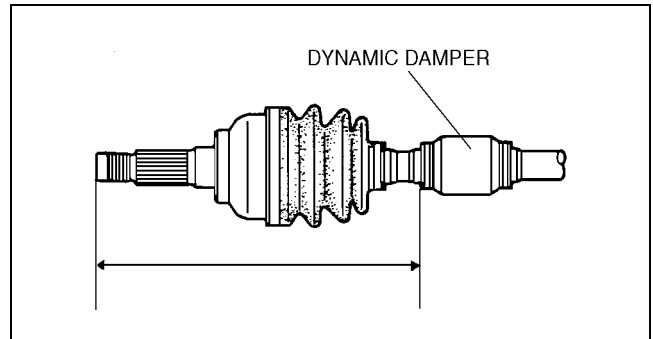

ZLU0313W141

## Boot Assembly Note

1. Fill the boot (wheel side) with the specified grease .

### Caution

- Do not touch grease with your hand. Apply it from the tube to prevent foreign matter from entering the boot.

### Note

- The wheel side and transaxle side boots are different.
- Use the specified grease supplied in the boot kit.

### Grease amount

ZM: 60—80 g {2.12—2.82 oz}

FS: 75—95 g {2.65—3.35 oz}

## DRIVE SHAFT

2. Install the boot with the splines of the shaft still wrapped in tape from disassembly.
3. Remove the tape.

### Tripod Joint Assembly Note

1. Align the marks and install the tripod joint using a bar and a hammer.

#### Caution

- Do not damage the roller.

2. Install the new snap ring using a snap-ring pliers.

#### Caution

- Install the snap ring in the shaft groove securely.

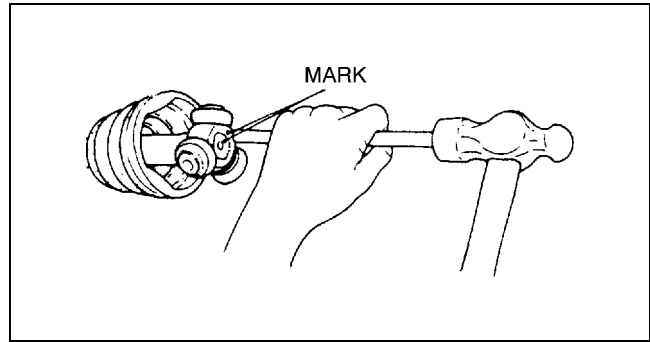

YDE6316W006

03-13

### Outer Ring Assembly Note

1. Fill the outer ring and boot (transaxle side) with the specified grease from a tube, not by hand.

#### Caution

- Do not touch grease with your hand. Apply it from the tube to prevent foreign matter from entering the boot.

#### Note

- Use the specified grease supplied in the boot kit.

#### Grease amount

115—135 g {4.06—4.76 oz}

2. Install the outer ring.
3. Set the drive shaft to the standard length.

### Standard length

mm {in}

Engine	Left side	Right side
ZM (MTX)	642.6—652.6 {25.30—25.69}	607.9—617.9 {23.94—24.32}
ZM (ATX)	626.7—636.7 {24.68—25.06}	
FS (MTX)	—	604.6—614.6 {23.81—24.19}
FS (ATX)	627.9—637.9 {24.73—25.11}	608.9—618.9 {23.98—24.36}

4. Release any trapped air from the boots by carefully lifting up the small end of each boot with a cloth wrapped screwdriver.

#### Caution

- Be careful not to allow the grease to leak.
- Do not damage the boot.

5. Verify that the drive shaft length is within the specification.

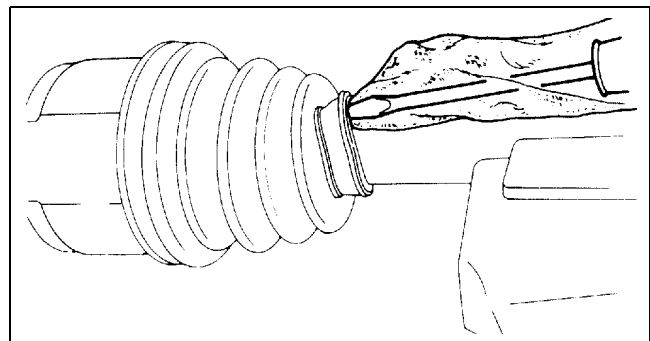

Y3E6316W033

## DRIVE SHAFT

### Boot Band (Transaxle Side) Assembly Note

1. Fold the band back and use pliers to pull it tight.

#### Note

- Always use new bands.
- The band should be folded in the direction opposite to the forward revolving direction of the drive shaft.

2. Lock the end of the band by bending the locking clips.

#### Caution

- Verify that the boot band is installed in the boot groove securely.

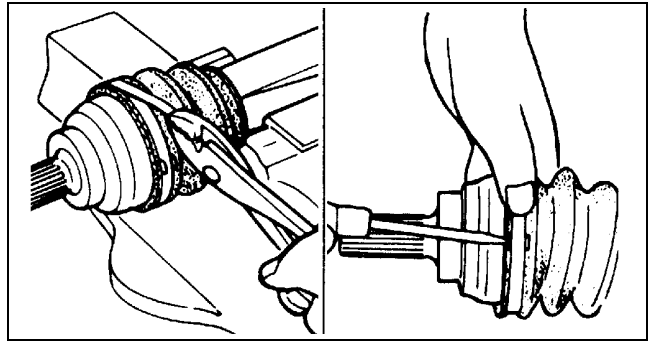

Y3E6316W035

### Boot Band (Wheel Side) Assembly Note

1. Adjust clearance A by turning the adjusting bolt of the SST.

#### Clearance A

2.9 mm {0.11 in}

2. Crimp the wheel side small boot band using the SST. Verify that clearance B is within the specification.
  - If clearance B is more than the specification, reduce clearance A of the SST and crimp the boot again.
  - If clearance B is less than the specification, replace the boot band, increase clearance A of the SST, and crimp the new boot.

#### Clearance B

2.4—2.8 mm {0.095—0.110 in}

3. Verify that the boot band does not protrude from the boot band installation area.
  - If it does, replace the boot band and repeat from Step 1.
4. Fill the boot with the repair kit grease.
5. Adjust clearance A by turning the adjusting bolt of the SST.

#### Clearance A

3.2 mm {0.13 in}

6. Crimp the wheel side big boot band using the SST.
7. Verify that clearance B is within the specification.
  - If clearance B is more than the specification, reduce clearance A of the SST and crimp the boot again.
  - If clearance B is less than the specification, replace the boot band, increase clearance A of the SST and crimp the new boot.

#### Clearance B

2.4—2.8 mm {0.095—0.110 in}

8. Verify that the boot band does not protrude from the boot band installation area.
  - If it does, replace the boot band and repeat from Steps 5.

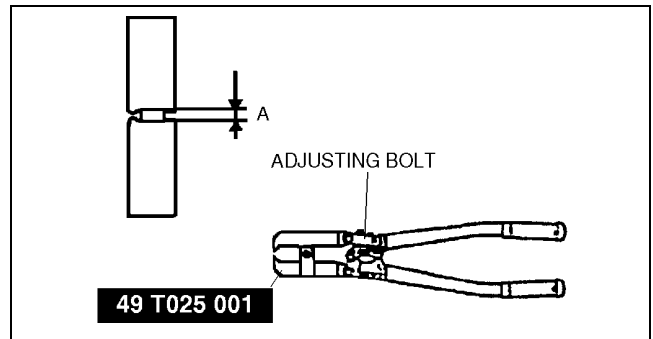

Z3U0313W009

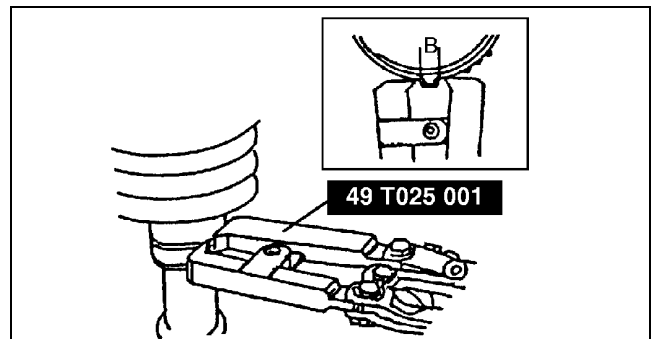

Y3E6316W028

# DRIVE SHAFT

## DRIVE SHAFT (FS MTX LEFT SIDE) DISASSEMBLY/ASSEMBLY

A3U031325500W05

1. Disassemble in the order indicated in the table.
2. Assemble in the reverse order of disassembly.

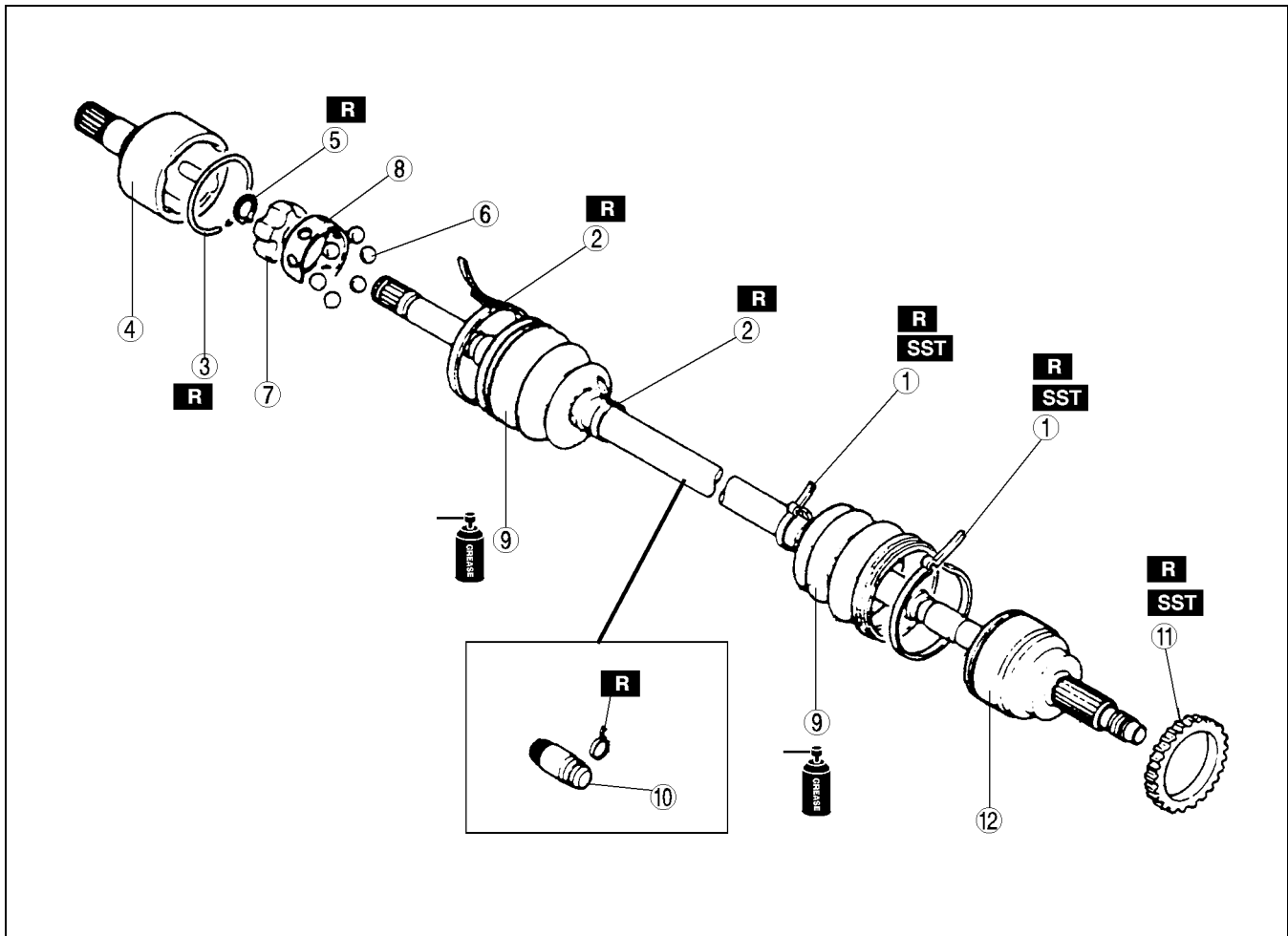

03-13

A3U0313W005

1	Boot band (wheel side) (See 03-13-12 DRIVE SHAFT (ZM, FS ATX, FS MTX RIGHT SIDE) DISASSEMBLY/ASSEMBLY)
2	Boot band (transaxle side) (See 03-13-12 DRIVE SHAFT (ZM, FS ATX, FS MTX RIGHT SIDE) DISASSEMBLY/ASSEMBLY)
3	Clip (See 03-13-18 Outer Ring Disassembly Note) (See 03-13-19 Outer Ring, Clip Assembly Note).
4	Outer ring (See 03-13-19 Outer Ring, Clip Assembly Note)
5	Snap ring (See 03-13-19 Cage, Inner Ring, Balls, Snap Ring Assembly Note)
6	Balls (See 03-13-18 Balls, Inner Ring, Cage Disassembly Note) (See 03-13-19 Cage, Inner Ring, Balls, Snap Ring Assembly Note)

7	Inner Ring (See 03-13-18 Balls, Inner Ring, Cage Disassembly Note) (See 03-13-19 Cage, Inner Ring, Balls, Snap Ring Assembly Note)
8	Cage (See 03-13-18 Balls, Inner Ring, Cage Disassembly Note) (See 03-13-19 Cage, Inner Ring, Balls, Snap Ring Assembly Note)
9	Boot (See 03-13-18 Boot Assembly Note)
10	Dynamic damper (See 03-13-18 Dynamic Damper Assembly Note)
11	ABS sensor rotor (See 03-13-12 DRIVE SHAFT (ZM, FS ATX, FS MTX RIGHT SIDE) DISASSEMBLY/ASSEMBLY)
12	Shaft and ball joint component

## DRIVE SHAFT

### Outer Ring Disassembly Note

1. Mark the drive shaft and outer ring for proper assembly.

#### Caution

- Mark with paint; do not use a punch.

2. Remove the clip.

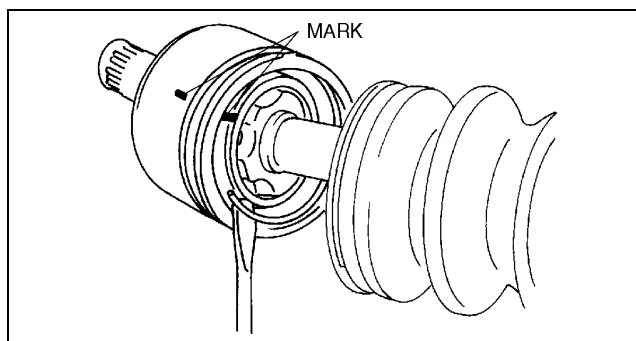

Z3U0313W005

### Balls, Inner Ring, Cage Disassembly Note

1. Mark the inner ring and cage.

#### Caution

- Mark with paint; do not use a punch.

2. Remove the snap ring using snap-ring pliers.
3. Turn the cage approximately 30 degree and pull the cage and balls away from the inner ring.

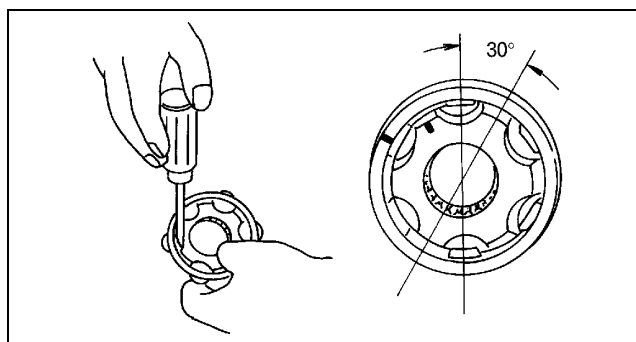

YYJ6316W007

### Dynamic Damper Assembly Note

1. Install the dynamic damper as shown in the figure.

#### Standard length

292—298 mm {11.5—11.7 in}

2. Install the new boot band onto the dynamic damper.

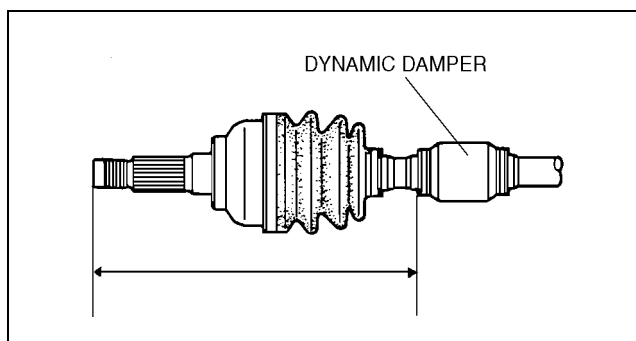

ZLU0313W141

### Boot Assembly Note

1. Fill the boot (wheel side) with the specified grease from a tube, not by hand.

#### Caution

- Do not touch grease with your hand. Apply it from the tube to prevent foreign matter from entering the boot.

#### Note

- The wheel side and transaxle side boots are different.
- Use the specified grease supplied in the boot kit.

#### Grease amount

75—95 g {2.65—3.35 oz}

## DRIVE SHAFT

2. With the splines of the shaft still wrapped in tape from disassembly, install the boot.
3. Remove the tape.

### Cage, Inner Ring, Balls, Snap Ring Assembly Note

1. Align the marks and install the balls and cage to the inner ring in the direction shown in the figure.

#### Caution

- Install the cage with the offset facing the snap ring groove. If incorrectly installed, the drive shaft may become disengaged.

2. Install a new snap ring.

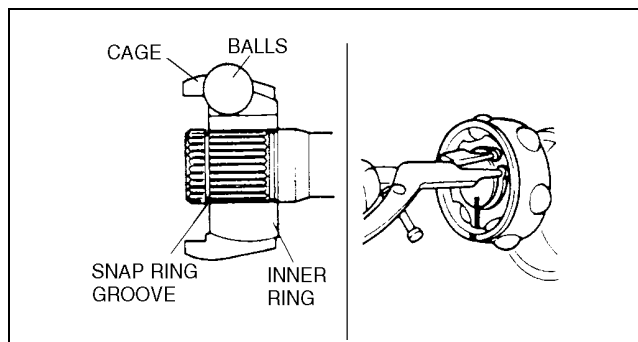

Z3U0313W006

03-13

### Outer Ring, Clip Assembly Note

1. Fill the outer ring and boot (transaxle side) with the specified grease.

#### Caution

- Do not touch grease with your hand. Apply it from the tube to prevent foreign matter from entering the boot.

#### Note

- Use the specified grease supplied in the boot kit.

#### Grease amount

95—115 g {3.36—4.05 oz}

2. Align the marks, and install the outer ring on to the shaft.
3. Install a new clip.
4. Install the boot.
5. Set the drive shaft to the standard length.

#### Standard length

641.0—651.0 {25.24—25.62}

6. Release any trapped air from the boots by carefully lifting up the small end of each boot with a cloth wrapped screwdriver.

#### Caution

- Be careful not to allow the grease to leak.
- Do not damage the boot.

7. Verify that the drive shaft length is within the specification.

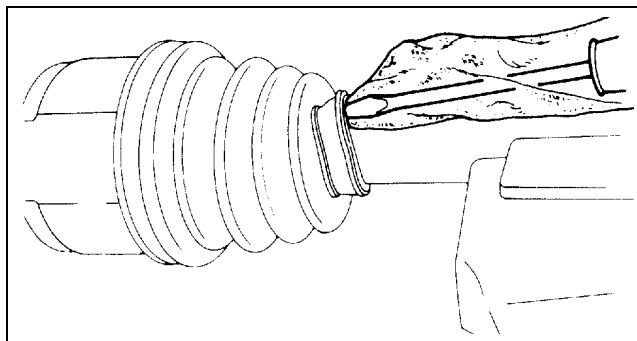

Y3E6316W033

# TECHNICAL DATA

## 03-50 TECHNICAL DATA

DRIVELINE/AXLE TECHNICAL DATA. . 03-50-1

### DRIVELINE/AXLE TECHNICAL DATA

A3U035001018W01

Item	ZM		FS		
	MTX	ATX	MTX	ATX	
<b>FRONT AXLE</b>					
Maximum wheel bearing play (mm {in})	0.05 {0.002}				
<b>REAR AXLE</b>					
Maximum wheel bearing play (mm {in})	0.05 {0.002}				
<b>DRIVE SHAFT</b>					
Shaft length (Air in boot at atmospheric pressure) (mm {in})	Left side	642.6—652.6 {25.30—25.69}	626.7—636.7 {24.68—25.06}	641.0—651.0 {25.24—25.62}	627.9—637.9 {24.73—25.11}
	Right side	607.9—617.9 {23.94—24.32}		604.6—614.6 {23.81—24.19}	608.9—618.9 {23.98—24.36}

03-50













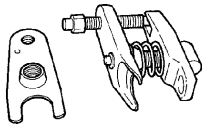
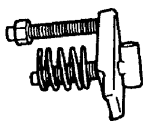

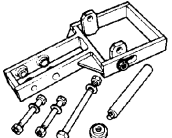
# SERVICE TOOLS

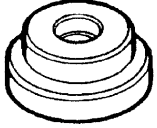
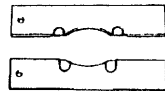
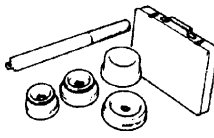
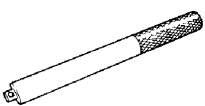
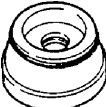
## 03-60 SERVICE TOOLS

DRIVELINE/AXLE SST ..... 03-60-1

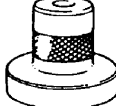

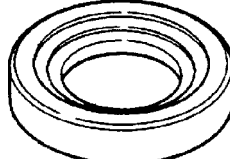
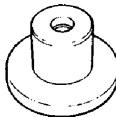
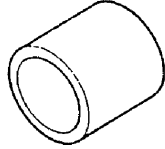
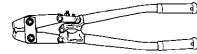
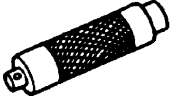

### DRIVELINE/AXLE SST

A3U036001018W01

<p>49 T028 3A0</p> <p>Ball joint puller set</p> 	<p>49 T028 303</p> <p>Body (Part of 49 T028 3A0)</p> 	<p>49 T028 304</p> <p>Attachment (Part of 49 T028 3A0)</p> 
<p>49 B026 1A0</p> <p>Wheel hub puller set</p> 	<p>49 G033 102</p> <p>Handle (Part of 49 B026 1A0)</p> 	<p>49 G030 727</p> <p>Attachment (Part of 49 B026 1A0)</p> 
<p>49 F026 103</p> <p>Wheel hub puller</p> 	<p>49 F027 0A1</p> <p>Bearing installer set</p> 	<p>49 F027 003</p> <p>Handle (Part of 49 F027 0A1)</p> 
<p>49 F027 005</p> <p>Attachment ø62 (Part of 49 F027 0A1)</p> 	<p>49 F027 007</p> <p>Attachment ø72 (Part of 49 F027 0A1)</p> 	<p>49 F027 009</p> <p>Attachment ø68 &amp; 77 (Part of 49 F027 0A1)</p> 
<p>49 E033 101</p> <p>Dust cover installer</p> 	<p>49 V001 795</p> <p>Oil seal installer</p> 	<p>49 B026 103</p> <p>Sensor rotor installer</p> 
<p>49 G026 105</p> <p>Sensor rotor installer</p> 	<p>49 F026 102</p> <p>Bearing installer</p> 	<p>49 W027 003</p> <p>Bearing installer</p> 
<p>49 T025 001</p> <p>Boot clamp crimper</p> 	<p>49 G030 797</p> <p>Handle (Part of 49 G030 795)</p> 	<p>49 B025 004</p> <p>Dust boot installer</p> 

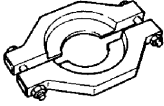
03-60

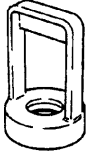
## SERVICE TOOLS

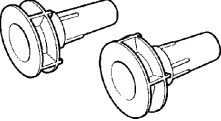
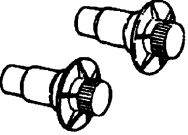
<p>49 H027 002</p> <p>Bearing installer</p> 	<p>49 H034 201</p> <p>Support block</p> 	<p>49 B025 006A</p> <p>Sensor rotor installer</p> 
<p>49 B025 009A</p> <p>Installer attachment</p> 	<p>49 B027 006</p> <p>Diff. side gear holder (MTX)</p> 	<p>49 G030 455</p> <p>Diff. side gear holder (ATX)</p> 

# BRAKES

# 04

SECTION

<b>ON-BOARD DIAGNOSTIC . . . . .</b> 04-02	<b>PARKING BRAKE SYSTEM . . . . .</b> 04-12
<b>SYMPTOM</b>	<b>ANTILOCK BRAKE</b>
<b>TROUBLESHOOTING . . . . .</b> 04-03	<b>SYSTEM. . . . .</b> 04-13
<b>GENERAL PROCEDURES. . . . .</b> 04-10	<b>TECHNICAL DATA . . . . .</b> 04-50
<b>CONVENTIONAL BRAKE</b>	<b>SERVICE TOOLS. . . . .</b> 04-60
<b>SYSTEM . . . . .</b> 04-11	

04-02

## 04-02 ON-BOARD DIAGNOSTIC

<b>ABS SYSTEM DIAGRAM. . . . .</b> 04-02-2	<b>DTC C1148 (41), C1158 (42),</b>
<b>ABS ON-BOARD DIAGNOSTIC . . . . .</b> 04-02-3	<b>C1168 (43), C1178 (44), C1233 (46),</b>
<b>On-Board Diagnostic (OBD)</b>	<b>C1234 (45), C1235 (47), C1236 (48) . . . . .</b> 04-02-12
<b>Test Description . . . . .</b> 04-02-3	<b>DTC C1194 (24), C1198 (25),</b>
<b>DTCs Retrieving Procedure . . . . .</b> 04-02-3	<b>C1210 (22), C1214 (23), C1242 (28),</b>
<b>DTCs Clearing Procedure. . . . .</b> 04-02-4	<b>C1246 (26), C1250 (29), C1254 (27) . . . . .</b> 04-02-14
<b>PID/Data Monitor and Record</b>	<b>DTC C1140 (30). . . . .</b> 04-02-14
<b>Procedure . . . . .</b> 04-02-4	<b>DTC C1510 (32), C1511 (33),</b>
<b>Active Command Modes Procedure . . . . .</b> 04-02-4	<b>C1512 (34), C1513 (35) . . . . .</b> 04-02-15
<b>DTC Table. . . . .</b> 04-02-5	<b>DTC C1186 (51), C1266 (52). . . . .</b> 04-02-16
<b>PID/DATA Monitor Table. . . . .</b> 04-02-8	<b>DTC C1095 (54), C1096 (53). . . . .</b> 04-02-17
<b>Active Command Modes Table. . . . .</b> 04-02-10	<b>DTC B1342 (61). . . . .</b> 04-02-18
<b>DTC C1145 (11), C1155 (12),</b>	<b>DTC B1318 (63). . . . .</b> 04-02-18
<b>C1165 (13), C1175 (14) . . . . .</b> 04-02-11	

# ON-BOARD DIAGNOSTIC

## ABS SYSTEM DIAGRAM

A3U040243000W01

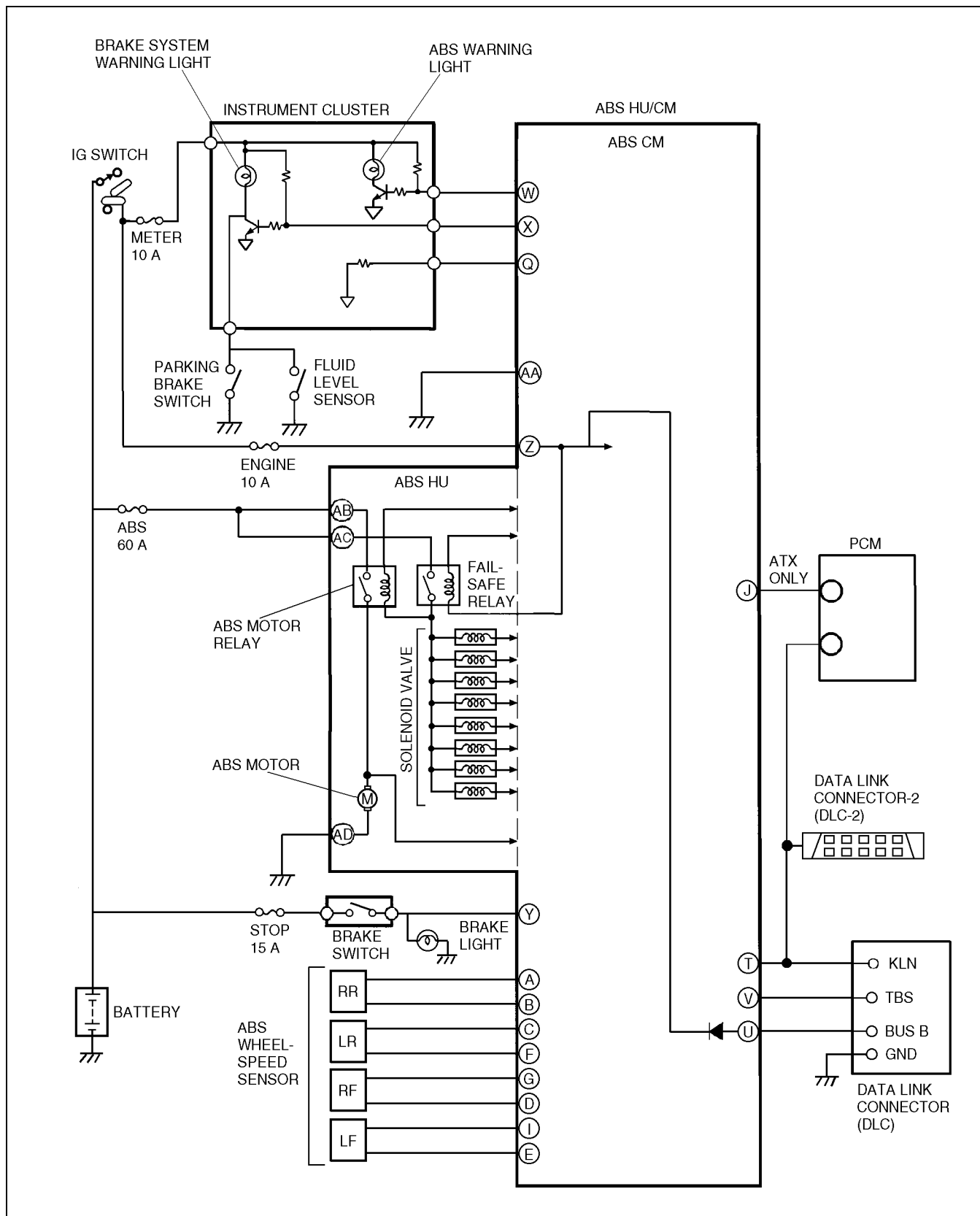

A3U0402W001

## ABS ON-BOARD DIAGNOSTIC

A3U040243000W02

### On-Board Diagnostic (OBD) Test Description

- The OBD test inspects the integrity and function of the ABS and outputs the results when requested by the specific tests.
- On-board diagnostic test also:
  - Provides a quick inspection of the ABS.
  - Is usually performed at the start of each diagnostic procedure.
  - Provides verification after repairs to ensure that no other faults occurred during service.
- The OBD test is divided into 3 tests:
  - Read/clear diagnostic results, PID monitor and record and active command modes.

### Read/clear diagnostic results

- This function allows you to read or clear DTCs in the ABS HU/CM memory.

### PID/data monitor and record

- This function allows you to access certain data values, input signals, calculated values, and system status information.

### Active command modes

- This function allows you to control devices through the **SST** (WDS or equivalent).

### DTCs Retrieving Procedure

#### Using SST (WDS or equivalent)

1. Connect WDS or equivalent to the vehicle DLC-2 16-pin connector located the left side of the steering column.
2. Retrieve DTC by WDS or equivalent.

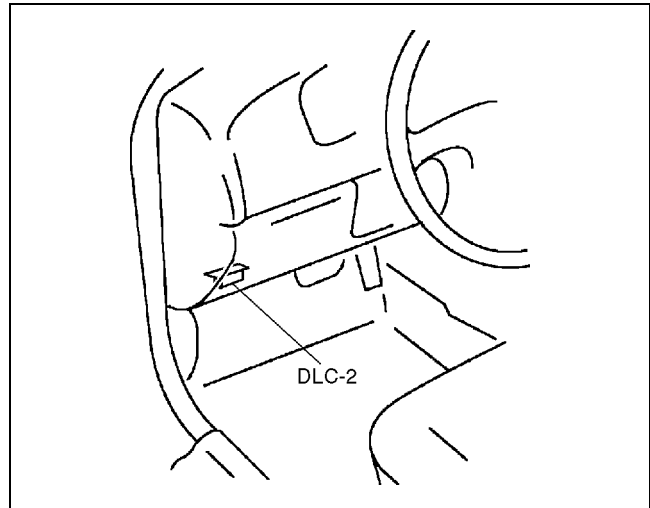

Z3U0102W001

#### Without using SST (WDS or equivalent)

##### Caution

- **Connecting the wrong DLC terminal may possibly cause a malfunction. Carefully connect the specified terminal only.**

1. Connect the TBS terminal at DLC to body ground using a jumper wire.
2. Turn the ignition key to ON (engine OFF).

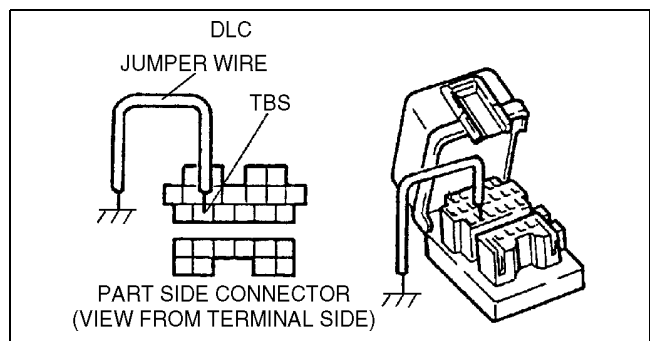

Z3U0402W001

## ON-BOARD DIAGNOSTIC

3. After the ABS warning light illuminates for **3 sec**, the ABS warning light indicates DTCs.
4. After completion of repairs, clear DTCs.

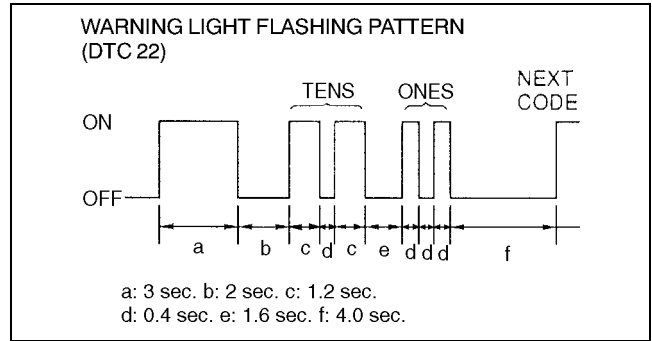

YMU402WA1

### DTCs Clearing Procedure Using SST (WDS or equivalent)

1. After repairs have been made, perform the **DTCs retrieving procedure**.
2. Erase DTC by WDS or equivalent.
3. Ensure that the customer's concern has been resolved.

#### Note

- After repairing the ABS wheel-speed sensor or replacing ABS HU/CM, the ABS and/or BRAKE system warning light may not go off when ignition key is turned ON. In this case, start engine and drive the vehicle at a speed of more than **10 km/h {6.2 mph}** until the ABS and/or BRAKE system warning light goes off.

### Without using SST (WDS or equivalent)

#### Caution

- **Connecting the wrong DLC terminal may possibly cause a malfunction. Carefully connect the specified terminal only.**

1. Connect the TBS terminal at the DLC to body ground using a jumper wire.
2. Turn the ignition key to ON (engine OFF).
3. Output all stored DTCs.
4. After verifying that the first code is repeated, depress the brake pedal **10 times** at intervals of less than **1 second**.
5. Turn the ignition key to OFF and disconnect the jumper wire.
6. Turn the ignition key to ON and verify the ABS warning light turns off after **3 seconds**.

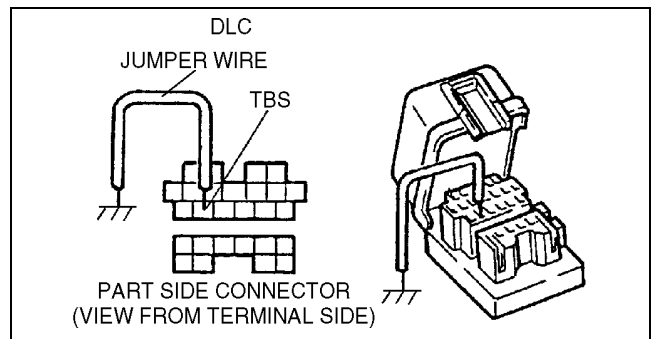

Z3U0402W001

#### Note

- DTCs cannot be cleared if the following conditions occur:
  - If intervals of depressing the brake pedal exceed **1 second**.
  - The brake switch has failed.
- After repairing the ABS wheel-speed sensor or replacing ABS HU/CM, the ABS and/or BRAKE system warning light may not go off when ignition key is turned ON. In this case, start engine and drive the vehicle at a speed of more than **10 km/h {6.2 mph}** until the ABS and/or BRAKE system warning light goes off.

### PID/Data Monitor and Record Procedure

1. Connect WDS or equivalent to the vehicle DLC-2 16-pin connector located the left side of the steering column.
2. Access and monitor PIDs by WDS or equivalent.

### Active Command Modes Procedure





#### Note

- When driving, the ABS motor and each valve forcibly turn ABS\_POWER on, and then each command on. ABS\_POWER regulates the power supply for the ABS motor and 8 valves.

1. Connect WDS or equivalent to the vehicle DLC-2 16-pin connector located the left side of the steering column.
2. Turn the ignition key to ON (Engine OFF) or start engine.
3. Activate active command modes by WDS or equivalent.

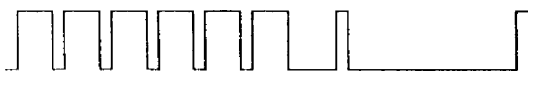

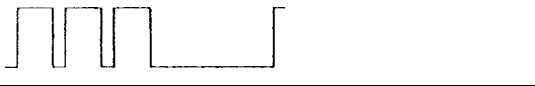
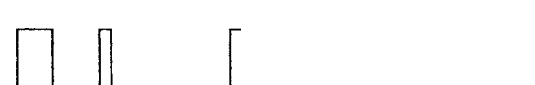
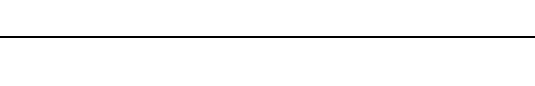
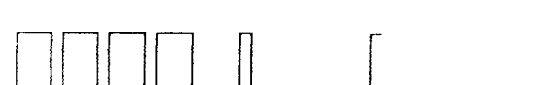

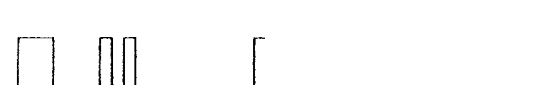
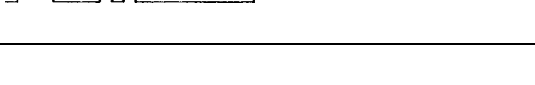

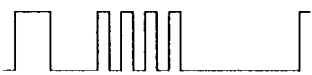

# ON-BOARD DIAGNOSTIC

**DTC Table**

DTC		ABS warning light flashing pattern	DTC definition	Diagnosis system component	Page
WDS or equivalent	ABS warning light				
B1318	63		Battery low voltage	ABS HU/CM power supply	(See 04-02-18 DTC B1318 (63).)
B1342	61		Defective ABS CM	ABS HU/CM (CM)	(See 04-02-18 DTC B1342 (61).)
C1095	54		Circuit failure of ABS motor and/or motor relay	ABS motor, motor relay	(See 04-02-17 DTC C1095 (54), C1096 (53).)
C1096	53		Open circuit of ABS motor and/or motor relay	ABS motor, motor relay	(See 04-02-17 DTC C1095 (54), C1096 (53).)
C1140	30		ABS HU failure	ABS HU/CM (pump)	(See 04-02-14 DTC C1140 (30).)
C1145	11		Circuit failure of RF ABS wheel-speed sensor	Right front ABS wheel-speed sensor	(See 04-02-11 DTC C1145 (11), C1155 (12), C1165 (13), C1175 (14).)
C1148	41		RF ABS wheel-speed sensor and/or sensor rotor malfunction	Right front ABS wheel-speed sensor/sensor rotor	(See 04-02-12 DTC C1148 (41), C1158 (42), C1168 (43), C1178 (44), C1233 (46), C1234 (45), C1235 (47), C1236 (48).)
C1155	12		Circuit failure of LF ABS wheel-speed sensor	Left front ABS wheel-speed sensor	(See 04-02-11 DTC C1145 (11), C1155 (12), C1165 (13), C1175 (14).)
C1158	42		LF ABS wheel-speed sensor and/or sensor rotor malfunction	Left front ABS wheel-speed sensor/sensor rotor	(See 04-02-12 DTC C1148 (41), C1158 (42), C1168 (43), C1178 (44), C1233 (46), C1234 (45), C1235 (47), C1236 (48).)
C1165	13		Circuit failure of RR ABS wheel-speed sensor	Right rear ABS wheel-speed sensor	(See 04-02-11 DTC C1145 (11), C1155 (12), C1165 (13), C1175 (14).)
C1168	43		RR ABS wheel-speed sensor and/or sensor rotor malfunction	Right rear ABS wheel-speed sensor/sensor rotor	(See 04-02-12 DTC C1148 (41), C1158 (42), C1168 (43), C1178 (44), C1233 (46), C1234 (45), C1235 (47), C1236 (48).)

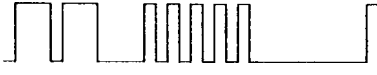

04-02

## ON-BOARD DIAGNOSTIC





DTC		ABS warning light flashing pattern	DTC definition	Diagnosis system component	Page
WDS or equivalent	ABS warning light				
C1175	14		Circuit failure of LR ABS wheel-speed sensor	Left rear wheel-speed sensor	(See 04-02-11 DTC C1145 (11), C1155 (12), C1165 (13), C1175 (14).)
C1178	44		LR ABS wheel-speed sensor and/or sensor rotor malfunction	Left rear ABS wheel-speed sensor/sensor rotor	(See 04-02-12 DTC C1148 (41), C1158 (42), C1168 (43), C1178 (44), C1233 (46), C1234 (45), C1235 (47), C1236 (48).)
C1186	51		Open circuit of fail-safe relay	Fail-safe relay	(See 04-02-16 DTC C1186 (51), C1266 (52).)
C1194	24		LF pressure reduction solenoid valve malfunction	Left front ABS pressure reduction solenoid valve	(See 04-02-14 DTC C1194 (24), C1198 (25), C1210 (22), C1214 (23), C1242 (28), C1246 (26), C1250 (29), C1254 (27).)
C1198	25		LF pressure retention solenoid valve malfunction	Left front ABS pressure retention solenoid valve	(See 04-02-14 DTC C1194 (24), C1198 (25), C1210 (22), C1214 (23), C1242 (28), C1246 (26), C1250 (29), C1254 (27).)
C1210	22		RF pressure reduction solenoid valve malfunction	Right front ABS pressure reduction solenoid valve	(See 04-02-14 DTC C1194 (24), C1198 (25), C1210 (22), C1214 (23), C1242 (28), C1246 (26), C1250 (29), C1254 (27).)
C1214	23		RF pressure retention solenoid valve malfunction	Right front ABS pressure retention solenoid valve	(See 04-02-14 DTC C1194 (24), C1198 (25), C1210 (22), C1214 (23), C1242 (28), C1246 (26), C1250 (29), C1254 (27).)
C1233	46		LF ABS wheel-speed sensor input signal missing	Left front ABS wheel-speed sensor/sensor rotor	(See 04-02-12 DTC C1148 (41), C1158 (42), C1168 (43), C1178 (44), C1233 (46), C1234 (45), C1235 (47), C1236 (48).)

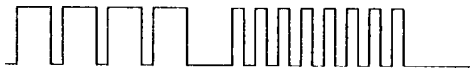
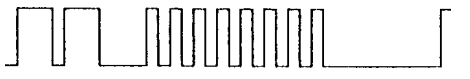
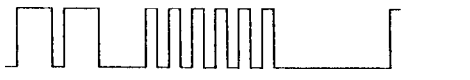
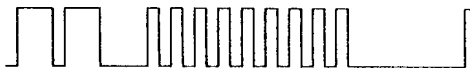
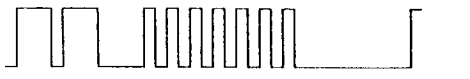

## ON-BOARD DIAGNOSTIC

DTC		ABS warning light flashing pattern	DTC definition	Diagnosis system component	Page
WDS or equivalent	ABS warning light				
C1234	45		RF ABS wheel-speed sensor input signal missing	Right front ABS wheel-speed sensor/sensor rotor	(See 04-02-12 DTC C1148 (41), C1158 (42), C1168 (43), C1178 (44), C1233 (46), C1234 (45), C1235 (47), C1236 (48).)
C1235	47		RR ABS wheel-speed sensor input signal missing	Right rear ABS wheel-speed sensor/sensor rotor	(See 04-02-12 DTC C1148 (41), C1158 (42), C1168 (43), C1178 (44), C1233 (46), C1234 (45), C1235 (47), C1236 (48).)
C1236	48		LR ABS wheel-speed sensor input signal missing	Left rear ABS wheel-speed sensor/sensor rotor	(See 04-02-12 DTC C1148 (41), C1158 (42), C1168 (43), C1178 (44), C1233 (46), C1234 (45), C1235 (47), C1236 (48).)
C1242	28		LR pressure reduction solenoid valve malfunction	Left rear ABS pressure reduction solenoid valve	(See 04-02-14 DTC C1194 (24), C1198 (25), C1210 (22), C1214 (23), C1242 (28), C1246 (26), C1250 (29), C1254 (27).)
C1246	26		RR pressure reduction solenoid valve malfunction	Right rear ABS pressure reduction solenoid valve	(See 04-02-14 DTC C1194 (24), C1198 (25), C1210 (22), C1214 (23), C1242 (28), C1246 (26), C1250 (29), C1254 (27).)
C1250	29		LR pressure retention solenoid valve malfunction	Left rear ABS pressure retention solenoid valve	(See 04-02-14 DTC C1194 (24), C1198 (25), C1210 (22), C1214 (23), C1242 (28), C1246 (26), C1250 (29), C1254 (27).)
C1254	27		RR pressure retention solenoid valve malfunction	Right rear ABS pressure retention solenoid valve	(See 04-02-14 DTC C1194 (24), C1198 (25), C1210 (22), C1214 (23), C1242 (28), C1246 (26), C1250 (29), C1254 (27).)

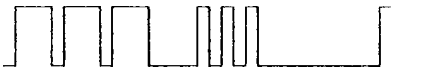
## ON-BOARD DIAGNOSTIC

DTC		ABS warning light flashing pattern	DTC definition	Diagnosis system component	Page
WDS or equivalent	ABS warning light				
C1266	52		Circuit failure of fail-safe relay	Fail-safe relay	(See 04-02-16 DTC C1186 (51), C1266 (52).)
C1510	32		RF ABS wheel-speed sensor and/or ABS HU malfunction	Right front solenoid valve, ABS motor, right front ABS wheel-speed sensor/sensor rotor	(See 04-02-15 DTC C1510 (32), C1511 (33), C1512 (34), C1513 (35).)
C1511	33		LF ABS wheel-speed sensor and/or ABS HU malfunction	Left front solenoid valve, ABS motor, left front ABS wheel-speed sensor/sensor rotor	(See 04-02-15 DTC C1510 (32), C1511 (33), C1512 (34), C1513 (35).)
C1512	34		RR ABS wheel-speed sensor and/or ABS HU malfunction	Right rear solenoid valve, ABS motor, right rear ABS wheel-speed sensor/sensor rotor	(See 04-02-15 DTC C1510 (32), C1511 (33), C1512 (34), C1513 (35).)
C1513	35		LR ABS wheel-speed sensor and/or ABS HU malfunction	Left rear solenoid valve, ABS motor, left rear ABS wheel-speed sensor/sensor rotor	(See 04-02-15 DTC C1510 (32), C1511 (33), C1512 (34), C1513 (35).)

**PID/DATA Monitor Table**

PID Name (Definition)	Unit/Condition	Condition/Specification	Action	ABS HU/CM terminal
ABS_LAMP (ABS warning light output state)	ON/OFF	<ul style="list-style-type: none"> <li>ABS warning light is illuminated: ON</li> <li>ABS warning light is not illuminated: OFF</li> </ul>	Inspect ABS warning light (See 09-22-3 INSTRUMENT CLUSTER REMOVAL/INSTALLATION)	W
ABSLF_I (Left front ABS pressure retention solenoid valve output state)	ON/OFF	<ul style="list-style-type: none"> <li>During ABS and/or EBD control: ON/OFF (solenoid valve is activated/deactivated)</li> <li>Not ABS and/or EBD control: OFF (solenoid valve is deactivated)</li> </ul>	Internal fault of ABS HU/CM. Replace ABS HU/CM (See 04-13-5 ABS HYDRAULIC UNIT (HU)/CONTROL MODULE (CM) REMOVAL/INSTALLATION)	—
ABSLF_O (Left front ABS pressure reduction solenoid valve output state)	ON/OFF	<ul style="list-style-type: none"> <li>During ABS and/or EBD control: ON/OFF (solenoid valve is activated/deactivated)</li> <li>Not ABS and/or EBD control: OFF (solenoid valve is deactivated)</li> </ul>	Internal fault of ABS HU/CM. Replace ABS HU/CM (See 04-13-5 ABS HYDRAULIC UNIT (HU)/CONTROL MODULE (CM) REMOVAL/INSTALLATION)	—
ABSLR_I (Left rear ABS pressure retention solenoid valve output state)	ON/OFF	<ul style="list-style-type: none"> <li>During ABS and/or EBD control: ON/OFF (solenoid valve is activated/deactivated)</li> <li>Not ABS and/or EBD control: OFF (solenoid valve is deactivated)</li> </ul>	Internal fault of ABS HU/CM. Replace ABS HU/CM (See 04-13-5 ABS HYDRAULIC UNIT (HU)/CONTROL MODULE (CM) REMOVAL/INSTALLATION)	—

## ON-BOARD DIAGNOSTIC

PID Name (Definition)	Unit/Condition	Condition/Specification	Action	ABS HU/CM terminal
ABSLR_O (Left rear ABS pressure reduction solenoid valve output state)	ON/OFF	<ul style="list-style-type: none"> <li>During ABS and/or EBD control: ON/OFF (solenoid valve is activated/deactivated)</li> <li>Not ABS and/or EBD control: OFF (solenoid valve is deactivated)</li> </ul>	Internal fault of ABS HU/CM. Replace ABS HU/CM (See 04-13-5 ABS HYDRAULIC UNIT (HU)/CONTROL MODULE (CM) REMOVAL/INSTALLATION)	—
ABSRF_I (Right front ABS pressure retention solenoid valve output state)	ON/OFF	<ul style="list-style-type: none"> <li>During ABS and/or EBD control: ON/OFF (solenoid valve is activated/deactivated)</li> <li>Not ABS and/or EBD control: OFF (solenoid valve is deactivated)</li> </ul>	Internal fault of ABS HU/CM. Replace ABS HU/CM (See 04-13-5 ABS HYDRAULIC UNIT (HU)/CONTROL MODULE (CM) REMOVAL/INSTALLATION)	—
ABSRF_O (Right front ABS pressure reduction solenoid valve output state)	ON/OFF	<ul style="list-style-type: none"> <li>During ABS and/or EBD control: ON/OFF (solenoid valve is activated/deactivated)</li> <li>Not ABS and/or EBD control: OFF (solenoid valve is deactivated)</li> </ul>	Internal fault of ABS HU/CM. Replace ABS HU/CM (See 04-13-5 ABS HYDRAULIC UNIT (HU)/CONTROL MODULE (CM) REMOVAL/INSTALLATION)	—
ABSRR_I (Right rear ABS pressure retention solenoid valve output state)	ON/OFF	<ul style="list-style-type: none"> <li>During ABS and/or EBD control: ON/OFF (solenoid valve is activated/deactivated)</li> <li>Not ABS and/or EBD control: OFF (solenoid valve is deactivated)</li> </ul>	Internal fault of ABS HU/CM. Replace ABS HU/CM (See 04-13-5 ABS HYDRAULIC UNIT (HU)/CONTROL MODULE (CM) REMOVAL/INSTALLATION)	—
ABSRR_O (Right rear ABS pressure reduction solenoid valve output state)	ON/OFF	<ul style="list-style-type: none"> <li>During ABS and/or EBD control: ON/OFF (solenoid valve is activated/deactivated)</li> <li>Not ABS and/or EBD control: OFF (solenoid valve is deactivated)</li> </ul>	Internal fault of ABS HU/CM. Replace ABS HU/CM (See 04-13-5 ABS HYDRAULIC UNIT (HU)/CONTROL MODULE (CM) REMOVAL/INSTALLATION)	—
ABS_VOLT (System battery voltage value)	V	<ul style="list-style-type: none"> <li>Ignition key at ON: B+</li> <li>Idle: 14—16V</li> </ul>	Inspect power supply circuit (See 04-13-6 ABS HYDRAULIC UNIT (HU)/CONTROL MODULE (CM) INSPECTION)	—
BOO_ABS (Brake pedal switch input)	ON/OFF	<ul style="list-style-type: none"> <li>Brake pedal is depressed: ON</li> <li>Brake pedal is released: OFF</li> </ul>	Inspect brake switch (See 04-11-5 BRAKE SWITCH INSPECTION)	Y
BRAKE_LMP (BRAKE system warning light output state)	ON/OFF	<ul style="list-style-type: none"> <li>BRAKE system warning light is illuminated: ON</li> <li>BRAKE system warning light is not illuminated: OFF</li> </ul>	Inspect BRAKE system warning light (See 09-22-3 INSTRUMENT CLUSTER REMOVAL/INSTALLATION)	X
CCNTABS (Number of continuous DTC)	—	<ul style="list-style-type: none"> <li>DTC is detected: 1—255</li> <li>DTC is not detected: 0</li> </ul>	Perform inspection using appropriate DTC (See 04-02-3 ABS ON-BOARD DIAGNOSTIC)	—
LF_WSPD (Left front ABS wheel-speed sensor input)	KPH/MPH	<ul style="list-style-type: none"> <li>Vehicle is stopped: 0KPH {0MPH}</li> <li>Indicates vehicle speed</li> </ul>	Inspect ABS wheel-speed sensor/sensor rotor. (See 04-13-9 FRONT/REAR ABS WHEEL-SPEED SENSOR INSPECTION)	I, E

04-02

## ON-BOARD DIAGNOSTIC

PID Name (Definition)	Unit/Condition	Condition/Specification	Action	ABS HU/CM terminal
LR_WSPD (Left rear ABS wheel-speed sensor input)	KPH/MPH	<ul style="list-style-type: none"> <li>Vehicle is stopped: 0KPH {0MPH}</li> <li>Indicates vehicle speed</li> </ul>	Inspect ABS wheel-speed sensor/sensor rotor. (See 04-13-9 FRONT/ REAR ABS WHEEL-SPEED SENSOR INSPECTION)	C, F
PMP_MTR (ABS motor relay output state)	ON/OFF	<ul style="list-style-type: none"> <li>During ABS and/or EBD control: ON/OFF (ABS motor is activated/deactivated)</li> <li>Not ABS and/or EBD control: OFF (ABS motor is deactivated)</li> </ul>	Inspect ABS HU/CM connector and ABS HU/CM (See 04-13-3 ABS HYDRAULIC UNIT (HU)/ CONTROL MODULE (CM) SYSTEM INSPECTION)	—
PMP_STAT (ABS motor output state)	ON/OFF	<ul style="list-style-type: none"> <li>During ABS and/or EBD control: ON/OFF (ABS motor is activated/deactivated)</li> <li>Not ABS and/or EBD control: OFF (ABS motor is deactivated)</li> </ul>	Inspect ABS HU/CM connector and ABS HU/CM (See 04-13-3 ABS HYDRAULIC UNIT (HU)/ CONTROL MODULE (CM) SYSTEM INSPECTION)	—
RF_WSPD (Right front ABS wheel-speed sensor input)	KPH/MPH	<ul style="list-style-type: none"> <li>Vehicle is stopped: 0KPH {0MPH}</li> <li>Indicates vehicle speed</li> </ul>	Inspect ABS wheel-speed sensor/sensor rotor. (See 04-13-9 FRONT/ REAR ABS WHEEL-SPEED SENSOR INSPECTION)	D, G
RR_WSPD (Right rear ABS wheel-speed sensor input)	KPH/MPH	<ul style="list-style-type: none"> <li>Vehicle is stopped: 0KPH {0MPH}</li> <li>Indicates vehicle speed</li> </ul>	Inspect ABS wheel-speed sensor/sensor rotor. (See 04-13-9 FRONT/ REAR ABS WHEEL-SPEED SENSOR INSPECTION)	A, B
ABSVLVRLY (Fail-safe relay output state)	ON/OFF	<ul style="list-style-type: none"> <li>Ignition key at ON: ON</li> <li>Other condition (Power supply circuit is open): OFF</li> </ul>	Inspect ABS HU/CM connector and ABS HU/CM (See 04-13-3 ABS HYDRAULIC UNIT (HU)/ CONTROL MODULE (CM) SYSTEM INSPECTION)	—

**Active Command Modes Table**

Command Name	Definition	Operation	Note
PMP_MOTOR	ABS motor	ON/OFF	Ignition key at ON (engine OFF), and driving
RF_OUTLET	Right front ABS pressure reduction solenoid valve	ON/OFF	
RF_INLET	Right front ABS pressure retention solenoid valve	ON/OFF	
LF_OUTLET	Left front ABS pressure reduction solenoid valve	ON/OFF	
LF_INLET	Left front ABS pressure retention solenoid valve	ON/OFF	
RR_OUTLET	Right rear ABS pressure reduction solenoid valve	ON/OFF	
RR_INLET	Right rear ABS pressure retention solenoid valve	ON/OFF	
LR_OUTLET	Left rear ABS pressure reduction solenoid valve	ON/OFF	
LR_INLET	Left rear ABS pressure retention solenoid valve	ON/OFF	
ABS_POWER	Fail-safe relay	ON/OFF	
VS_OUTPUT	Vehicle speed signal	KPH/MPH	

**Note**

- When operating, the ABS motor and each valve forcibly turn ABS\_POWER on, and then each command on. ABS\_POWER regulates the power supply for the ABS motor and 8 valves.



# ON-BOARD DIAGNOSTIC

DTC C1145 (11), C1155 (12), C1165 (13), C1175 (14)

A3U040243000W03

**Caution**

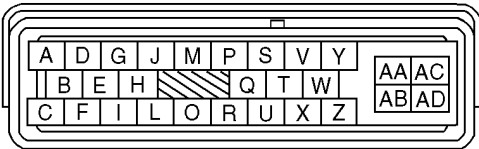
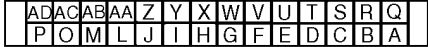
- When attaching the tester lead to the ABS HU/CM or the ABS HU/CM harness connector the SST (49 G066 001) must be used. (See 04-13-6 ABS HYDRAULIC UNIT (HU)/CONTROL MODULE (CM) INSPECTION.)

DTC	C1145 (11) C1155 (12) C1165 (13) C1175 (14)	RF ABS wheel-speed sensor LF ABS wheel-speed sensor RR ABS wheel-speed sensor LR ABS wheel-speed sensor
DETECTION CONDITION	<ul style="list-style-type: none"> <li>When open or short circuit is detected.</li> </ul>	
POSSIBLE CAUSE	<ul style="list-style-type: none"> <li>Open circuit or short to power circuit of ABS wheel-speed sensor(s) circuit</li> <li>ABS wheel-speed sensor(s) malfunction</li> </ul>	
<div style="display: flex; justify-content: space-around; align-items: flex-start;"> <div style="text-align: center;"> <p>ABS HU/CM</p>  <p>HARNESS SIDE CONNECTOR (VIEW FROM TERMINAL SIDE)</p> </div> <div style="text-align: center;"> <p>SST (49 G066 001) CONNECTOR</p>  <p>(VIEW FROM TERMINAL SIDE)</p> <p>ABS WHEEL-SENSOR LF, RF                      LR, RR</p>  <p>HARNESS SIDE CONNECTOR (VIEW FROM TERMINAL SIDE)</p> </div> </div>		

04-02

**Diagnostic procedure**

STEP	INSPECTION		ACTION
1	<b>INSPECT ABS WHEEL-SPEED SENSOR CIRCUIT FOR OPEN CIRCUIT</b> <ul style="list-style-type: none"> <li>Turn ignition key to OFF.</li> <li>Disconnect ABS HU/CM connector.</li> <li>Connect <b>SST</b> (adapter harness) to ABS HU/CM connector (harness side) with ABS HU/CM disconnected.</li> <li>Measure resistance between suspected sensor terminals of <b>SST</b>.                             <ul style="list-style-type: none"> <li>RF ABS wheel-speed sensor: G—D</li> <li>LF ABS wheel-speed sensor: E—I</li> <li>RR ABS wheel-speed sensor: A—B</li> <li>LR ABS wheel-speed sensor: C—F</li> </ul> </li> <li>Is resistance <b>within 1.3—1.7 kilohm</b>?</li> </ul>	Yes	Go to next step.
		No	Go to Step 3.
2	<b>INSPECT ABS WHEEL-SPEED SENSOR CIRCUIT FOR SHORT TO POWER</b> <ul style="list-style-type: none"> <li>Turn ignition key to ON (engine OFF).</li> <li>Inspect voltage between suspected sensor terminal(s) of <b>SST</b> (adapter harness) and ground(s).                             <ul style="list-style-type: none"> <li>RF ABS wheel-speed sensor: G, D</li> <li>LF ABS wheel-speed sensor: I, E</li> <li>RR ABS wheel-speed sensor: A, B</li> <li>LR ABS wheel-speed sensor: C, F</li> </ul> </li> <li>Is there any <b>B+</b>?</li> </ul>	Yes	Repair or replace harness for short to power circuit between ABS HU/CM and ABS wheel-speed sensor(s), then go to Step 5.
		No	Go to Step 5.
3	<b>INSPECT ABS WHEEL-SPEED SENSOR</b> <ul style="list-style-type: none"> <li>Turn ignition key to OFF.</li> <li>Disconnect suspected sensor connector(s) and inspect resistance between sensor terminals (part side).</li> <li>Is resistance <b>within 1.3—1.7 kilohm</b>?</li> </ul>	Yes	Go to next step.
		No	Replace ABS wheel-speed sensor, then go to Step 5.

# ON-BOARD DIAGNOSTIC



STEP	INSPECTION	ACTION
4	<b>INSPECT ABS HU/CM TO ABS WHEEL-SPEED SENSOR CIRCUIT FOR OPEN CIRCUIT</b> <ul style="list-style-type: none"> <li>Inspect continuity between suspected sensor terminal(s) of <b>SST</b> and ABS wheel-speed sensor connector. (vehicle harness side)                             <ul style="list-style-type: none"> <li>— RF ABS wheel-speed sensor (+): G-1</li> <li>— RF ABS wheel-speed sensor (-): D-2</li> <li>— LF ABS wheel-speed sensor (+): I-1</li> <li>— LF ABS wheel-speed sensor (-): E-2</li> <li>— RR ABS wheel-speed sensor (+): A-1</li> <li>— RR ABS wheel-speed sensor (-): B-2</li> <li>— LR ABS wheel-speed sensor (+): C-1</li> <li>— LR ABS wheel-speed sensor (-): F-2</li> </ul> </li> <li>Is there continuity?</li> </ul>	Yes Repair or replace poor connections of ABS HU/CM connector and/or ABS wheel-speed sensor connector(s), then go to next step.
		No Repair or replace harness for open circuits between ABS HU/CM and ABS wheel-speed sensor(s), then go to next step.
5	<b>VERIFY TROUBLESHOOTING COMPLETED</b> <ul style="list-style-type: none"> <li>Make sure to reconnect all disconnected connectors.</li> <li>Clear DTC from memory (See 04-02-4 DTCs Clearing Procedure)</li> <li>Is same DTC present?</li> </ul>	Yes Replace ABS HU/CM, then go to next step.
		No Go to next step.
6	<b>VERIFY AFTER REPAIR PROCEDURE</b> <ul style="list-style-type: none"> <li>Is there any other DTC present?</li> </ul>	Yes Go to applicable DTC inspection.
		No Troubleshooting completed.

**DTC C1148 (41), C1158 (42), C1168 (43), C1178 (44), C1233 (46), C1234 (45), C1235 (47), C1236 (48)**

A3U040243000W04

**Caution**

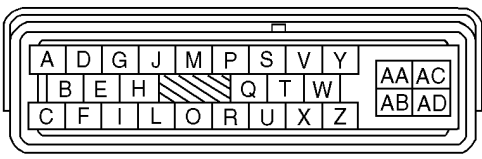
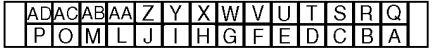
- When attaching the tester lead to the ABS HU/CM or the ABS HU/CM harness connector the **SST (49 G066 001)** must be used. (See 04-13-6 ABS HYDRAULIC UNIT (HU)/CONTROL MODULE (CM) INSPECTION.)

<b>DTC</b>	<b>C1148 (41), C1234 (45)</b> <b>C1158 (42), C1233 (46)</b> <b>C1168 (43), C1235 (47)</b> <b>C1178 (44), C1236 (48)</b>	<b>RF ABS wheel-speed sensor/sensor rotor</b> <b>LF ABS wheel-speed sensor/sensor rotor</b> <b>RR ABS wheel-speed sensor/sensor rotor</b> <b>LR ABS wheel-speed sensor/sensor rotor</b>
<b>DETECTION CONDITION</b>	<ul style="list-style-type: none"> <li>C1148 (41), C1158 (42), C1168 (43), C1178 (44): ABS wheel-speed signal is out of specification when just after vehicle has started to move.</li> <li>C1234 (45), C1233 (46), C1235 (47), C1236 (48): ABS wheel-speed signal malfunction (distortion/sudden change) is detected during driving.</li> </ul>	
<b>POSSIBLE CAUSE</b>	<ul style="list-style-type: none"> <li>Short to ground circuit of ABS wheel-speed sensor(s) circuit</li> <li>ABS wheel-speed sensor(s) malfunction</li> <li>Damaged ABS sensor rotor(s)</li> <li>Incorrect clearance between ABS sensor and sensor rotor</li> </ul>	
<div style="display: flex; justify-content: space-around; align-items: flex-start;"> <div style="text-align: center;"> <p>ABS HU/CM</p>  <p>HARNESS SIDE CONNECTOR (VIEW FROM TERMINAL SIDE)</p> </div> <div style="text-align: center;"> <p>SST (49 G066 001) CONNECTOR</p>  <p>(VIEW FROM TERMINAL SIDE)</p> <p>ABS WHEEL-SENSOR LF, RF                      LR, RR</p>  <p>HARNESS SIDE CONNECTOR (VIEW FROM TERMINAL SIDE)</p> </div> </div>		

## ON-BOARD DIAGNOSTIC

### Diagnostic procedure

STEP	INSPECTION	ACTION	
1	<b>VERIFY CURRENT INPUT SIGNAL STATUS OF CONCERN IS INTERMITTENT OR CONSTANT</b> <ul style="list-style-type: none"> <li>• Turn ignition key to OFF.</li> <li>• Connect <b>SST</b> (WDS or equivalent) to DLC-2.</li> <li>• Start engine and drive vehicle.</li> <li>• Access LF_WSPD, LR_WSPD, RF_WSPD and RR_WSPD PID using <b>SST</b> (WDS or equivalent)</li> <li>• Are PIDs display vehicle speed and 4 PIDs equal?</li> </ul>	Yes	Go to Step 5.
		No	Go to next step.
2	<b>INSPECT ABS WHEEL-SPEED SENSOR CIRCUIT FOR SHORT TO GROUND</b> <ul style="list-style-type: none"> <li>• Turn ignition key to OFF.</li> <li>• Disconnect ABS HU/CM connector.</li> <li>• Connect <b>SST</b> (adapter harness) to ABS HU/CM connector (harness side) with ABS HU/CM disconnected.</li> <li>• Inspect continuity between suspected sensor terminal(s) of <b>SST</b> (adapter harness) and ground(s).                             <ul style="list-style-type: none"> <li>— RF ABS wheel-speed sensor: G</li> <li>— LF ABS wheel-speed sensor: I</li> <li>— RR ABS wheel-speed sensor: A</li> <li>— LR ABS wheel-speed sensor: C</li> </ul> </li> <li>• Is there continuity?</li> </ul>	Yes	Go to next step.
		No	Go to Step 4.
3	<b>INSPECT ABS WHEEL-SPEED SENSOR FOR SHORT TO GROUND</b> <ul style="list-style-type: none"> <li>• With ignition key at OFF, disconnected suspected sensor connector(s), inspect continuity between suspected sensor terminal(s) 1 (part side) and ground(s).</li> <li>• Is there continuity?</li> </ul>	Yes	Replace ABS wheel-speed sensor(s), then go to Step 8.
		No	Repair or replace harness (short to ground) between ABS HU/CM and ABS wheel-speed sensor connector(s), then go to Step 8.
4	<b>INSPECT SENSOR ROTOR CLEARANCE</b> <ul style="list-style-type: none"> <li>• Jack-up vehicle and support it with safety stands.</li> <li>• Remove suspected wheel(s).</li> <li>• Inspect clearance between sensor and rotor.</li> <li>• Is clearance <b>within 0.3—1.1 mm {0.012—0.043 in}</b>?</li> </ul>	Yes	Go to Step 8.
		No	Replace ABS wheel-speed sensor(s), then go to Step 8.
5	<b>INSPECT ABS WHEEL-SPEED SENSOR OUTPUT PULSE</b> <ul style="list-style-type: none"> <li>• Start engine and drive vehicle.</li> <li>• Inspect output voltage pattern using an oscilloscope. (See 04-13-10 Voltage Pattern Inspection)</li> <li>• Is output voltage pattern okay?</li> </ul>	Yes	Go to Step 8.
		No	Go to next step.
6	<b>INSPECT SENSOR ROTOR FOR DAMAGE</b> <ul style="list-style-type: none"> <li>• Jack-up vehicle and support it with safety stands.</li> <li>• Remove suspected wheel(s).</li> <li>• Visually inspect sensor rotor for missing, deformed and obstructed teeth. <b>Number of teeth: 44</b></li> <li>• Is sensor rotor okay?</li> </ul>	Yes	Go to next step.
		No	Replace rotor, then go to Step 8.
7	<b>INSPECT SENSOR ROTOR CLEARANCE</b> <ul style="list-style-type: none"> <li>• Inspect clearance between sensor and rotor.</li> <li>• Is clearance <b>within 0.3—1.1 mm {0.012—0.043 in}</b>?</li> </ul>	Yes	Go to next step.
		No	Replace ABS wheel-speed sensor, then go to next step.

04-02

## ON-BOARD DIAGNOSTIC

STEP	INSPECTION	ACTION	
8	<b>VERIFY TROUBLESHOOTING COMPLETED</b> <ul style="list-style-type: none"> <li>Make sure to reconnected all disconnected connectors.</li> <li>Clear DTC from memory. (See 04-02-4 DTCs Clearing Procedure)</li> <li>Start engine and drive vehicle at <b>10 km/h {6.2 mph}</b> or above.</li> <li>Gradually slow down vehicle and stop.</li> <li>Is same DTC present?</li> </ul>	Yes	Replace ABS HU/CM, then go to next step.
		No	Go to next step.
9	<b>VERIFY AFTER REPAIR PROCEDURE</b> <ul style="list-style-type: none"> <li>Is there any other DTC present?</li> </ul>	Yes	Go to applicable DTC inspection.
		No	Troubleshooting completed.

### DTC C1194 (24), C1198 (25), C1210 (22), C1214 (23), C1242 (28), C1246 (26), C1250 (29), C1254 (27)

A3U040243000W05

DTC	C 1210 (22) C 1214 (23) C 1194 (24) C 1198 (25) C 1246 (26) C 1254 (27) C 1242 (28) C 1250 (29)	RF pressure reduction solenoid valve RF pressure retention solenoid valve LF pressure reduction solenoid valve LF pressure retention solenoid valve RR pressure reduction solenoid valve RR pressure retention solenoid valve LR pressure reduction solenoid valve LR solenoid pressure retention valve
<b>DETECTION CONDITION</b>	Solenoid monitor signal does not track in response to solenoid ON/OFF command.	
<b>POSSIBLE CAUSE</b>	<ul style="list-style-type: none"> <li>Open circuit, short to power or short to ground of solenoid valve circuit in ABS HU/CM</li> <li>Stuck solenoid valve in ABS HU/CM</li> </ul>	

#### Diagnostic Procedure

STEP	INSPECTION	ACTION	
1	<b>VERIFY CURRENT STATUS OF MALFUNCTION</b> <ul style="list-style-type: none"> <li>Clear DTC from memory. (See 04-02-4 DTCs Clearing Procedure)</li> <li>Start engine and drive vehicle at <b>10 km/h {6.2 mph}</b> or <b>above at least 1 minute</b>.</li> <li>Gradually slow down and stop vehicle.</li> <li>Is same DTC present?</li> </ul>	Yes	Replace ABS HU/CM, then go to next step.
		No	Go to next step.
2	<b>VERIFY AFTER REPAIR PROCEDURE</b> <ul style="list-style-type: none"> <li>Is there any other DTC present?</li> </ul>	Yes	Go to applicable DTC inspection.
		No	Troubleshooting completed.

### DTC C1140 (30)

A3U040243000W06

DTC	C1140 (30)	ABS HU/CM (pump)
<b>DETECTION CONDITION</b>	Right front and left rear wheels, or left front and right rear wheels lock is detected during ABS operation.	
<b>POSSIBLE CAUSE</b>	Stuck ABS pump in ABS HU/CM	

#### Diagnostic procedure

STEP	INSPECTION	ACTION	
1	<b>INSPECT ABS HU/CM OPERATION</b> <ul style="list-style-type: none"> <li>Perform ABS HU/CM system inspection. (See 04-13-3 System Inspection)</li> <li>Is it okay?</li> </ul>	Yes	Go to next step.
		No	Replace ABS HU/CM, then go to Step 4.
2	<b>INSPECT CONVENTIONAL BRAKE OPERATION</b> <ul style="list-style-type: none"> <li>Inspect brake fluid level.</li> <li>Start engine.</li> <li>Perform a road test to verify conventional vehicle braking performance.</li> <li>Is there any concern?</li> </ul>	Yes	Inspect conventional brake line, then go to Step 4.
		No	Go to next step.



## ON-BOARD DIAGNOSTIC

STEP	INSPECTION	ACTION
3	<b>INSPECT REAR BRAKE DRAGGING</b> <ul style="list-style-type: none"> <li>Turn ignition key to OFF.</li> <li>Jack-up vehicle and support it with safety stand.</li> <li>Release parking brake.</li> <li>Turn rear wheel by hand and inspect for rear brake drag.</li> <li>Is rear brake dragging?</li> </ul>	Yes Repair parking brake system, then go to next step.
		No Go to next step.
4	<b>VERIFY TROUBLESHOOTING COMPLETED</b> <ul style="list-style-type: none"> <li>Clear DTC from memory. (See 04-02-4 DTCs Clearing Procedure)</li> <li>Start engine and drive vehicle at <b>10 km/h {6.2 mph}</b> or <b>above at least 1 minute</b>.</li> <li>Gradually slow down vehicle and stop.</li> <li>Is same DTC present?</li> </ul>	Yes Replace ABS HU/CM, then go to next step.
		No Go to next step.
5	<b>VERIFY AFTER REPAIR PROCEDURE</b> <ul style="list-style-type: none"> <li>Is there any other DTC present?</li> </ul>	Yes Go to applicable DTC inspection.
		No Troubleshooting completed.

04-02

### DTC C1510 (32), C1511 (33), C1512 (34), C1513 (35)

A3U040243000W07

DTC	<b>C1510 (32)</b> <b>C1511 (33)</b> <b>C1512 (34)</b> <b>C1513 (35)</b>	<b>RF solenoid valve, ABS motor or RF ABS wheel-speed sensor/sensor rotor</b> <b>LF solenoid valve, ABS motor or LF ABS wheel-speed sensor/sensor rotor</b> <b>RR solenoid valve, ABS motor or RR ABS wheel-speed sensor/sensor rotor</b> <b>LR solenoid valve, ABS motor or LR ABS wheel-speed sensor/sensor rotor</b>
DETECTION CONDITION	<ul style="list-style-type: none"> <li>Wheel lock is detected during ABS operation (pressure reduction inoperative).</li> </ul>	
POSSIBLE CAUSE	<ul style="list-style-type: none"> <li>Low electrical power supply</li> <li>Malfunction of solenoid valve in ABS HU/CM</li> <li>Malfunction of ABS wheel-speed sensor</li> <li>Damaged ABS sensor rotor</li> <li>Stuck ABS motor in ABS HU/CM</li> <li>Malfunction of hydraulic unit of ABS HU/CM</li> </ul>	

### Diagnostic procedure

STEP	INSPECTION	ACTION
1	<b>VERIFY OTHER DTC HAS RECORDED</b> <ul style="list-style-type: none"> <li>Is DTC B1318 (63) also stored?</li> </ul>	Yes Go to DTC B1318 (63) inspection.
		No Go to next step.
2	<b>VERIFY OTHER DTC HAS RECORDED</b> <ul style="list-style-type: none"> <li>Is any of DTC C1214 (22), C1210 (23), C1198 (24), C1194 (25), C1254 (26), C1246 (27), C1250 (28) and/or C1242 (29) also stored?</li> </ul>	Yes Go to applicable DTC inspection.
		No Go to next step.
3	<b>VERIFY OTHER DTC HAS RECORDED</b> <ul style="list-style-type: none"> <li>Is any of DTC C1145 (11), C1148 (41), C1155 (12) C1158 (42), C1165 (13), C1168 (43), C1175 (14), C1178 (44), C1233 (46), C1234 (45), C1235 (47) and/or C1236 (48) also stored?</li> </ul>	Yes Go to applicable DTC inspection.
		No Go to next step.
4	<b>VERIFY OTHER DTC HAS RECORDER</b> <ul style="list-style-type: none"> <li>Is any of DTC C1095 (59) and/or C1096 (53) also stored?</li> </ul>	Yes Go to applicable DTC inspection.
		No Go to next step.
5	<b>INSPECT ABS HU/CM OPERATION</b> <ul style="list-style-type: none"> <li>Perform ABS HU/CM system inspection.(See 04-13-3 System Inspection)</li> <li>Is it okay?</li> </ul>	Yes Go to next step.
		No Replace ABS HU/CM, then go to next step.
6	<b>VERIFY CURRENT STATUS OF MALFUNCTION</b> <ul style="list-style-type: none"> <li>Clear DTC from memory. (See 04-02-4 DTCs Clearing Procedure)</li> <li>Start engine and drive vehicle at <b>10 km/h {6.2 mph}</b> or <b>above at least 1 minute</b>.</li> <li>Gradually slow down and stop vehicle.</li> <li>Is same DTC present?</li> </ul>	Yes Replace ABS HU/CM.
		No Go to next step.
7	<b>VERIFY AFTER REPAIR PROCEDURE</b> <ul style="list-style-type: none"> <li>Is there any other DTC present?</li> </ul>	Yes Go to applicable DTC inspection.
		No Troubleshooting completed.

# ON-BOARD DIAGNOSTIC

DTC C1186 (51), C1266 (52)

A3U040243000W08

**Caution**

- When attaching the tester lead to the ABS HU/CM or the ABS HU/CM harness connector the SST (49 G066 001) must be used. (See 04-13-6 ABS HYDRAULIC UNIT (HU)/CONTROL MODULE (CM) INSPECTION.)

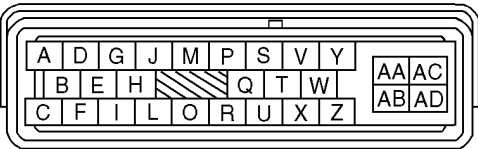
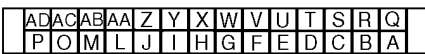
DTC	C1186 (51), C1266 (52)	Fail-safe relay
<b>DETECTION CONDITION</b>	<ul style="list-style-type: none"> <li>• C1186 (51): Fail-safe relay in ABS HU/CM stuck OFF when ignition switch is turned ON, fail-safe relay ON is commanded.</li> <li>• C1266 (52): Fail-safe relay in ABS HU/CM stuck ON when ignition switch is turned ON, fail-safe relay OFF is commanded.</li> </ul>	
<b>POSSIBLE CAUSE</b>	<ul style="list-style-type: none"> <li>• Open circuit, short to power or short to ground circuit of fail-safe relay in ABS HU/CM</li> <li>• Stuck ON or OFF of fail-safe relay in ABS HU/CM</li> <li>• Open circuit of fail-safe relay power supply circuit</li> </ul>	
<div style="display: flex; justify-content: space-around; align-items: center;"> <div style="text-align: center;"> <p>ABS HU/CM</p>  <p>HARNESS SIDE CONNECTOR (VIEW FROM TERMINAL SIDE)</p> </div> <div style="text-align: center;"> <p>SST (49 G066 001) CONNECTOR</p>  <p>(VIEW FROM TERMINAL SIDE)</p> </div> </div>		

**Diagnostic procedure**

STEP	INSPECTION		ACTION
1	<b>INSPECT ABS FUSE CONDITION</b> <ul style="list-style-type: none"> <li>• Is ABS fuse (<b>60 A</b>) okay?</li> </ul>	Yes	Go to next step.
		No	Replace fuse, then go to Step 3.
2	<b>INSPECT FAIL-SAFE RELAY POWER SUPPLY CIRCUIT FOR OPEN CIRCUIT</b> <ul style="list-style-type: none"> <li>• Turn ignition key to OFF.</li> <li>• Disconnect ABS HU/CM connector.</li> <li>• Connect <b>SST</b> (adapter harness) to ABS HU/CM connector (harness side) with ABS HU/CM disconnected.</li> <li>• Turn ignition key to ON (engine OFF).</li> <li>• Measure voltage between terminal AC of <b>SST</b> (adapter harness) and ground.</li> <li>• Is voltage <b>B+</b>?</li> </ul>	Yes	Go to next step.
		No	Repair or replace harness for open circuit between battery positive terminal and ABS HU/CM terminal AC, then go to next step.
3	<b>VERIFY TROUBLESHOOTING COMPLETED</b> <ul style="list-style-type: none"> <li>• Make sure to reconnected all disconnected connectors.</li> <li>• Clear DTC from memory. (See 04-02-4 DTCs Clearing Procedure)</li> <li>• Is same DTC present?</li> </ul>	Yes	Replace ABS HU/CM, then go to next step.
		No	Go to next step.
4	<b>VERIFY AFTER REPAIR PROCEDURE</b> <ul style="list-style-type: none"> <li>• Is there any DTC present?</li> </ul>	Yes	Go to applicable DTC inspection.
		No	Troubleshooting completed.

# ON-BOARD DIAGNOSTIC

**DTC C1095 (54), C1096 (53)**

A3U04024300W09

**Caution**

- When attaching the tester lead to the ABS HU/CM or the ABS HU/CM harnesses connector the **SST (49 G066 001)** must be used. (See 04–13–6 ABS HYDRAULIC UNIT (HU)/CONTROL MODULE (CM) INSPECTION.)

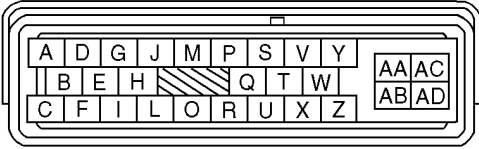
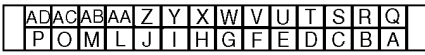
DTC	C1095 (53), C1096 (54)	Motor relay, ABS Motor
<b>DETECTION CONDITION</b>	<ul style="list-style-type: none"> <li>• C1095 (53): ABS motor stuck OFF when vehicle is started or during ABS operation, ABS motor ON is commanded.</li> <li>• C1096 (54): ABS motor stuck ON when vehicle is started or during ABS operation, ABS motor OFF is commanded.</li> </ul>	
<b>POSSIBLE CAUSE</b>	<ul style="list-style-type: none"> <li>• Open circuit, or short power or short to ground of motor relay and/or ABS motor in ABS HU/CM</li> <li>• Stuck motor relay and/or ABS motor</li> <li>• Open circuit of ABS motor power supply</li> <li>• Open circuit of ABS motor ground</li> </ul>	
<div style="display: flex; justify-content: space-around; align-items: center;"> <div style="text-align: center;"> <p>ABS HU/CM</p>  <p>HARNESS SIDE CONNECTOR (VIEW FROM TERMINAL SIDE)</p> </div> <div style="text-align: center;"> <p>SST (49 G066 001) CONNECTOR</p>  <p>(VIEW FROM TERMINAL SIDE)</p> </div> </div>		

04-02

**Diagnostic procedure**

STEP	INSPECTION		ACTION
1	<b>VERIFY OTHER DTC HAS RECORDED</b> <ul style="list-style-type: none"> <li>• If any of DTC C1186 (51) and/or C1266 (52) also stored?</li> </ul>	Yes	Go to applicable DTC inspection.
		No	Go to next step.
2	<b>INSPECT ABS FUSE CONDITION</b> <ul style="list-style-type: none"> <li>• Is ABS fuse (60 A) okay?</li> </ul>	Yes	Go to next step.
		No	Replace fuse, then go to Step 5.
3	<b>INSPECT MOTOR RELAY POWER SUPPLY CIRCUIT FOR OPEN</b> <ul style="list-style-type: none"> <li>• Turn ignition key to OFF.</li> <li>• Disconnect ABS HU/CM connector.</li> <li>• Connect <b>SST</b> (adapter harness) to ABS HU/CM connector (harness side) with HU/CM disconnected.</li> <li>• Turn ignition key to ON (engine OFF).</li> <li>• Measure voltage between ABS HU/CM terminal AB (harness side) and ground.</li> <li>• Is voltage <b>B+</b>?</li> </ul>	Yes	Go to next step.
		No	Repair or replace harness for open circuit between battery positive terminal and ABS HU/CM terminal AB, then go to Step 5.
4	<b>INSPECT ABS HU/CM GROUND CIRCUIT FOR OPEN CIRCUIT</b> <ul style="list-style-type: none"> <li>• Turn ignition key to OFF.</li> <li>• Inspect continuity between ABS HU/CM terminal AD of <b>SST</b> and ground.</li> <li>• Is there continuity?</li> </ul>	Yes	Go to next step.
		No	Repair or replace harness for open circuit between ABS HU/CM terminal AD and ground, then go to next step.
5	<b>VERIFY TROUBLESHOOTING COMPLETED</b> <ul style="list-style-type: none"> <li>• Make sure to reconnected all disconnected connectors.</li> <li>• Clear DTC from memory. (See 04–02–4 DTCs Clearing Procedure)</li> <li>• Start engine and drive vehicle at <b>10 km/h {6.2 mph}</b> or above.</li> <li>• Gradually slow down and stop vehicle.</li> <li>• Is same DTC present?</li> </ul>	Yes	Replace ABS HU/CM, then go to next step.
		No	Go to next step.
6	<b>VERIFY AFTER REPAIR PROCEDURE</b> <ul style="list-style-type: none"> <li>• Is there any other DTC present?</li> </ul>	Yes	Go to applicable DTC inspection.
		No	Troubleshooting completed.

# ON-BOARD DIAGNOSTIC

## DTC B1342 (61)

A3U040243000W10

<b>DTC B1342 (61)</b>	<b>ABS HU/CM (CM)</b>
<b>DETECTION CONDITION</b>	The on-board diagnostic function detects computer malfunction.
<b>POSSIBLE CAUSE</b>	<ul style="list-style-type: none"> <li>Malfunction of ABS HU/CM</li> </ul>

### Diagnostic procedure

STEP	INSPECTION		ACTION
1	<b>VERIFY CURRENT STATUS OF MALFUNCTION</b> <ul style="list-style-type: none"> <li>Clear DTC from memory. (See 04-02-4 DTCs Clearing Procedure)</li> <li>Start engine and drive vehicle at <b>10 km/h {6.2 mph}</b> or above.</li> <li>Is same DTC present?</li> </ul>	Yes	Replace ABS HU/CM, then go to next step.
		No	Go to next step.
2	<b>VERIFY AFTER REPAIR PROCEDURE</b> <ul style="list-style-type: none"> <li>Is there any other DTC present?</li> </ul>	Yes	Go to applicable DTC inspection.
		No	Troubleshooting completed.

## DTC B1318 (63)

A3U040243000W11

### Caution

- When attaching the tester lead to the ABS HU/CM or the ABS HU/CM harnesses connector the **SST (49 G066 001)** must be used. (See 04-13-6 ABS HYDRAULIC UNIT (HU)/CONTROL MODULE (CM) INSPECTION.)

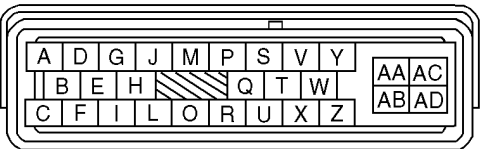
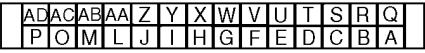
<b>DTC B1318 (63)</b>	<b>ABS HU/CM power supply</b>
<b>DETECTION CONDITION</b>	<ul style="list-style-type: none"> <li>Voltage at Z terminal of ABS HU/CM drops <b>below 10 V</b> when driving vehicle.</li> </ul>
<b>POSSIBLE CAUSE</b>	<ul style="list-style-type: none"> <li>Low power supply</li> <li>Battery and/or generator malfunction</li> <li>Poor ground or open circuit of ground</li> </ul>
<div style="display: flex; justify-content: space-around; align-items: center;"> <div style="text-align: center;"> <p>ABS HU/CM</p>  <p>HARNESS SIDE CONNECTOR (VIEW FROM TERMINAL SIDE)</p> </div> <div style="text-align: center;"> <p>SST (49 G066 001) CONNECTOR</p>  <p>(VIEW FROM TERMINAL SIDE)</p> </div> </div>	

### Diagnostic procedure

STEP	INSPECTION		ACTION
1	<b>INSPECT ABS HU/CM POWER SUPPLY CIRCUIT FOR OPEN CIRCUIT</b> <ul style="list-style-type: none"> <li>Turn ignition key to OFF.</li> <li>Disconnect ABS HU/CM connector.</li> <li>Connect <b>SST</b> (adapter harness) to ABS HU/CM connector (harness side) with ABS HU/CM disconnected.</li> <li>Start engine.</li> <li>Measure voltage between terminal Z of <b>SST</b> (harness side) and ground.</li> <li>Is voltage <b>above 10 V</b>?</li> </ul>	Yes	Go to next step.
		No	Go to Step 3.

## ON-BOARD DIAGNOSTIC

STEP	INSPECTION	ACTION	
2	<b>INSPECT ABS HU/CM GROUND CIRCUIT FOR POOR GROUND AND OPEN CIRCUIT</b> <ul style="list-style-type: none"> <li>• Turn ignition key to OFF.</li> <li>• Measure resistance between terminal AA of <b>SST</b> and ground.</li> <li>• Is resistance <b>within 0—1 ohm</b>?</li> </ul>	Yes	Go to Step 5.
		No	If there is no continuity: <ul style="list-style-type: none"> <li>• Repair or replace harness for open between ABS HU/CM and ground, then go to Step 5.</li> </ul> If resistance is not <b>within 0—1 ohm</b> : <ul style="list-style-type: none"> <li>• Repair or replace harness for poor ground then go to Step 5.</li> </ul>
3	<b>INSPECT BATTERY POWER</b> <ul style="list-style-type: none"> <li>• Inspect battery. (See 01-50-1 ENGINE TECHNICAL DATA)</li> <li>• Is it okay?</li> </ul>	Yes	Go to next step.
		No	Replace battery, then go to Step 5.
4	<b>INSPECT GENERATOR</b> <ul style="list-style-type: none"> <li>• Inspect generator. (See 01-17-3 GENERATOR INSPECTION)</li> <li>• Is it okay?</li> </ul>	Yes	Go to next step.
		No	Repair or replace generator, then go to Step 5.
5	<b>VERIFY TROUBLESHOOTING COMPLETED</b> <ul style="list-style-type: none"> <li>• Make sure to reconnected all disconnected connectors.</li> <li>• Clear DTC from memory. (See 04-02-4 DTCs Clearing Procedure)</li> <li>• Is same DTC present?</li> </ul>	Yes	Replace ABS HU/CM, then go to next step.
		No	Go to next step.
6	<b>VERIFY AFTER REPAIR PROCEDURE</b> <ul style="list-style-type: none"> <li>• Is there any other DTC present?</li> </ul>	Yes	Go to applicable DTC inspection.
		No	Troubleshooting completed.

04-02

---

## 04-03 SYMPTOM TROUBLESHOOTING

ABS SYSTEM DIAGRAM .....	04-03-2	NO.3 BRAKE SYSTEM WARNING LIGHT DOES NOT ILLUMINATE.....	04-03-7
FOREWORD .....	04-03-3	NO.4 ABS WARNING LIGHT AND BRAKE SYSTEM WARNING LIGHT STAY ON .....	04-03-8
ABS .....	04-03-3	NO.5 ABS WARNING LIGHT STAYS ON .....	04-03-10
Foreword .....	04-03-3	NO.6 BRAKE SYSTEM WARNING LIGHT STAYS ON .....	04-03-12
Precaution .....	04-03-3	NO.7 BRAKE SYSTEM MALFUNCTION .....	04-03-13
SYMPTOM TROUBLESHOOTING .....	04-03-4		
ABS Symptom Troubleshooting.....	04-03-4		
Quick Diagnosis Chart .....	04-03-5		
NO.1 NEITHER ABS WARNING LIGHT NOR BRAKE SYSTEM WARNING LIGHT ILLUMINATE.....	04-03-5		
NO.2 ABS WARNING LIGHT DOES NOT ILLUMINATE.....	04-03-6		

# SYMPTOM TROUBLESHOOTING

## ABS SYSTEM DIAGRAM

A3U040343000W01

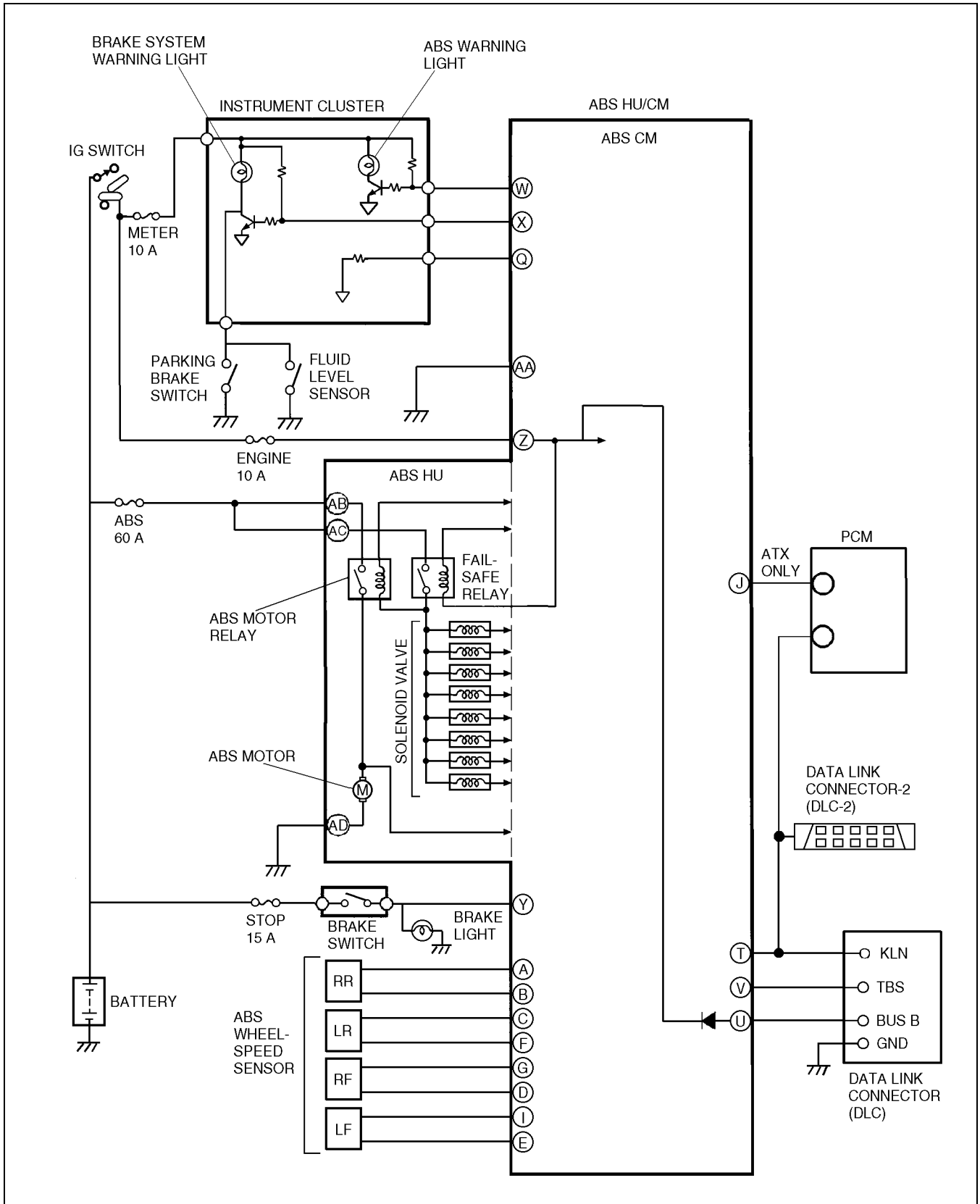

A3U0402W001

# SYMPTOM TROUBLESHOOTING

## FOREWORD

A3U040343000W02

- Before performing the steps in Symptom Troubleshooting, perform the On-board Diagnostic Test. To check the DTC, follow the OBD TEST steps.

## ABS

A3U040343000W03

### Foreword

- Before performing the steps in Symptom Troubleshooting, perform the On-board Diagnostic Inspection. To check the DTC, follow the DTC Inspection steps.

### Precaution

When inspecting or servicing the ABS, note the following points:

1. The ABS warning light and/or BRAKE system warning light illuminate even when the system is normal.

Warning lights that may illuminate	Cases in which the light may illuminate	Condition in which the light will go out	ABS and EBD control
<ul style="list-style-type: none"> <li>• ABS warning light</li> <li>• BRAKE system warning light (*1)</li> </ul>	Under any of the following conditions: <ul style="list-style-type: none"> <li>• When the front wheels are jacked up, stuck, or placed on a chassis roller, and only the front wheel ABS wheel speed sensors are spun for <b>more than 20 seconds</b>.</li> </ul> Parking brake is not fully released while driving. Brake drag. Sudden acceleration/ deceleration. Left/ right or front/ rear tires are different. (Size, radius, tire pressure, or wear is other than that listed on tire label.)	After turning ignition switch OFF, vehicle is driven at speed <b>greater than 10 km/h {6.2 mph}</b> and normal operation is confirmed.	<ul style="list-style-type: none"> <li>• ABS: Cuts control.</li> <li>• EBD:               <ol style="list-style-type: none"> <li>1. Cuts control, in cases where the light may illuminate, only when ABS HU/CM detects that a wheel speed sensor determines that more than 2 rear wheels are malfunctioning.</li> <li>2. Operates control, if wheel speed sensor determines that more than 3 wheels are functioning correctly.</li> </ol> </li> </ul>
<ul style="list-style-type: none"> <li>• ABS warning light</li> </ul>	Battery voltage at ABS HU/CM ignition terminal Z drops <b>below about 9 to 10 V. (*2)</b>	Battery voltage rises <b>above about 10 V.</b>	ABS: Operates control. EBD: Operates control.
<ul style="list-style-type: none"> <li>• ABS warning light</li> <li>• BRAKE system warning light</li> </ul>	Battery voltage at ABS HU/CM ignition terminal Z drops <b>below about 9 to 10 V. (*2)</b>	Battery voltage rises <b>above about 10 V.</b> (Only BRAKE system warning light goes out.) Battery voltage rises <b>above about 10 V.</b> (Both warning lights go out)	ABS: Operates control. EBD: Operates control.

04-03

\*1 : In cases where the light may illuminate, only when ABS HU/CM detects that a rear wheel's speed sensor is malfunctioning.

\*2 : If battery voltage drops **below about 9 to 10 V** while vehicle speed is **greater than 6 km/h {3.7 mph}**, ABS HU/CM records **DTC B1318 (DTC 63)**.

2. Precautions during servicing of ABS

The ABS is composed of electrical and mechanical parts. It is necessary to categorize malfunctions as being either electrical or hydraulic when performing troubleshooting.

#### (1) Malfunctions in electrical system

- The ABS hydraulic unit and control module (ABS HU/CM) has an on-board diagnostic function. With this function, the ABS warning light and/or BRAKE system warning light will come on when there is a problem in the electrical system. Also, past and present malfunctions are recorded in the ABS HU/CM. This function can find malfunctions that do not occur during periodic inspections. Turn the ignition switch on by connecting the **SST** (WDS or equivalent) to the DLC-2 inside the Passenger compartment. **Approximately 5 seconds** later the stored malfunctions will be displayed in order of occurrence. To find out the causes of ABS malfunctions, use these on-board diagnostic results.
- If a malfunction occurred in the past but is now normal, the cause is likely a temporary poor connection of the harness. The ABS HU/CM usually operates normally. Be careful when searching for the cause of malfunction.
- After repair, it is necessary to erase the DTC from the ABS HU/CM memory. Also, if the ABS related parts have been replaced, verify that the no DTC has been displayed after repairs.



## SYMPTOM TROUBLESHOOTING

- After repairing the ABS wheel-speed sensor or ABS sensor rotor, or after replacing the ABS HU/CM (ABS motor or ABS motor relay or solenoid valve), the ABS warning light may not go off even when the ignition switch is turned on. In this case, drive the vehicle at a speed of **more than 10 km/h {6.2 mph}**, make sure the ABS warning light goes off, and then erase the DTC.
  - When repairing, if the ABS related connectors are disconnected and the ignition switch is turned on, the ABS HU/CM will mistakenly detect a fault and record it as a malfunction.
  - To protect the ABS HU/CM, make sure the ignition is off before connecting or disconnecting the ABS HU/CM connector.
  - To protect the terminal, use the **SST** (49 G066 001) when connecting the tester lead to the ABS HU/CM connector.
- (2) Malfunctions in hydraulic system
- Symptoms in a hydraulic system malfunction are similar to those in a conventional brake malfunction. However, it is necessary to determine if the malfunction is in an ABS component or the conventional brake system.
  - The ABS hydraulic unit contains delicate mechanical parts. If foreign materials get into the component, the ABS may fail to operate. Also, it will likely become extremely difficult to find the location of the malfunction in the event that the brakes operate but the ABS does not. Make sure foreign materials do not get inside when servicing the ABS (e.g. brake fluid replacement, pipe removal).

### SYMPTOM TROUBLESHOOTING

A3U040343000W04

#### ABS Symptom Troubleshooting

- Verify the symptom, and perform troubleshooting according to the appropriate number.

No.	TROUBLESHOOTING ITEM	DESCRIPTION	PAGE
1	Neither ABS warning light nor BRAKE system warning light illuminate	Neither ABS warning light nor BRAKE system warning light illuminate with ignition switch on.	(See 04-03-5 NO.1 NEITHER ABS WARNING LIGHT NOR BRAKE SYSTEM WARNING LIGHT ILLUMINATE)
2	ABS warning light does not illuminate	ABS warning light does not illuminate with ignition switch on.	(See 04-03-6 NO.2 ABS WARNING LIGHT DOES NOT ILLUMINATE)
3	BRAKE system warning light does not illuminate	BRAKE system warning light does not illuminate with ignition switch on.	(See 04-03-7 NO.3 BRAKE SYSTEM WARNING LIGHT DOES NOT ILLUMINATE)
4	ABS warning light and BRAKE system warning light stay ON	Both ABS warning light BRAKE system warning light stay on <b>more than 4 seconds</b> with ignition switch on.	(See 04-03-8 NO.4 ABS WARNING LIGHT AND BRAKE SYSTEM WARNING LIGHT STAY ON)
5	ABS warning light stays ON	ABS warning light stays on <b>more than 4 seconds</b> with ignition switch on.	(See 04-03-10 NO.5 ABS WARNING LIGHT STAYS ON)
6	BRAKE system warning light stays ON	BRAKE system warning light stays on <b>more than 4 seconds</b> with ignition switch on. (Parking brake is released)	(See 04-03-12 NO.6 BRAKE SYSTEM WARNING LIGHT STAYS ON)
7	BRAKE system malfunction	There is a malfunction in system even though ABS warning light and BRAKE system warning light does not illuminate.	(See 04-03-13 NO.7 BRAKE SYSTEM MALFUNCTION)

# SYMPTOM TROUBLESHOOTING

## Quick Diagnosis Chart Vehicles with ABS

× : Applicable

Possible factor																
Troubleshooting item		ABS HU/CM	Instrument cluster	ABS warning light circuit	BRAKE system warning light circuit	Battery	Brake fluid	Brake fluid level sensor	Parking brake switch	Charging system	ABS HU/CM power supply (terminal Z)	ABS HU/CM GND 1 (terminal AA)	Instrument cluster power supply (terminal 1J)	Instrument cluster GND (terminal 1D)	Conventional brakes	Brake pipe routing
1	Neither ABS warning light nor BRAKE system warning light illuminate		×										×	×		
2	ABS warning light does not illuminate	×	×	×												
3	BRAKE system warning light does not illuminate	×	×		×											
4	ABS warning light and BRAKE system warning light stay ON	×	×	×	×	×				×	×	×				
5	ABS warning light stays ON	×	×	×		×				×						
6	BRAKE system warning light stays ON	×	×		×		×	×	×							
7	BRAKE system malfunction	×													×	×

04-03

Y3U403WA1

### NO.1 NEITHER ABS WARNING LIGHT NOR BRAKE SYSTEM WARNING LIGHT ILLUMINATE

A3U040343000W05

- When performing an asterisked (\*) troubleshooting inspection, shake the wiring harness and connectors while performing the inspection to discover whether poor contact points are the cause of any intermittent malfunctions. If there is a problem, check to make sure connectors, terminals and wiring harness are connected correctly and undamaged.

1	<b>Neither ABS warning light nor BRAKE system warning light illuminate</b>
<b>DESCRIPTION</b>	<ul style="list-style-type: none"> <li>Neither ABS warning light nor BRAKE system warning light illuminate with ignition switch on.</li> </ul>
<b>POSSIBLE CAUSE</b>	<ul style="list-style-type: none"> <li>Warning light circuit and indicator light circuits open circuit or shorted to ground.</li> </ul>
<p>INSTRUMENT CLUSTER CONNECTOR (18-PIN)</p> <p>(VIEW FROM HARNESS SIDE)</p>	

### Diagnostic procedure

STEP	INSPECTION		ACTION
1	<b>CHECK TO SEE WHETHER MALFUNCTION IS IN WARNING LIGHTS' COMMON POWER SUPPLY OR OTHER WARNING LIGHTS AND INDICATOR LIGHTS</b> <ul style="list-style-type: none"> <li>Do other warning and indicator lights illuminate when IG switch is turned ON?</li> </ul>	Yes	Replace instrument cluster (open circuit in instrument cluster).
		No	Go to next step.

## SYMPTOM TROUBLESHOOTING

STEP	INSPECTION	ACTION	
2	<b>CHECK TO SEE WHETHER MALFUNCTION IS IN WARNING LIGHTS' COMMON GROUND OR TURN SIGNAL INDICATOR LIGHT</b> <ul style="list-style-type: none"> <li>Turn ignition switch ON.</li> <li>Turn signal switch ON.</li> <li>Does turn signal indicator light in instrument cluster illuminate?</li> </ul>	Yes	Replace instrument cluster (open circuit in instrument cluster).
		No	Go to next step.
3	<b>INSPECT INSTRUMENT CLUSTER POWER SUPPLY FUSE</b> <ul style="list-style-type: none"> <li>Is instrument cluster ignition power supply fuse okay?</li> </ul>	Yes	Go to next step.
		No	Check for a short to ground on blown fuse's circuit. Repair or replace as necessary. Install appropriate amperage fuse.
*4	<b>INSPECT WIRING HARNESS BETWEEN INSTRUMENT CLUSTER POWER SUPPLY AND INSTRUMENT CLUSTER FOR CONTINUITY</b> <ul style="list-style-type: none"> <li>Turn ignition switch ON.</li> <li>Measure voltage at instrument cluster connector (18-pin) terminal 1J.</li> <li>Is voltage <b>approximately 12V</b>?</li> </ul>	Yes	Go to next step
		No	Repair wiring harness between fuse block and instrument cluster.
*5	<b>CHECK TO SEE WHETHER MALFUNCTION (LACK OF CONTINUITY) IS IN WIRING HARNESS (BETWEEN INSTRUMENT CLUSTER AND GROUND) OR INSTRUMENT CLUSTER</b> <ul style="list-style-type: none"> <li>Turn ignition switch to LOCK.</li> <li>Disconnect instrument cluster connector.</li> <li>Is there continuity between instrument cluster connector (18-pin) terminal 1D and ground?</li> </ul>	Yes	Replace instrument cluster (open circuit in instrument cluster).
		No	Repair wiring harness between instrument cluster and ground.

### NO.2 ABS WARNING LIGHT DOES NOT ILLUMINATE

A3U040343000W06

- When performing an asterisked (\*) troubleshooting inspection, shake the wiring harness and connectors while performing the inspection to discover whether poor contact points are the cause of any intermittent malfunctions. If there is a problem, check to make sure connectors, terminals and wiring harness are connected correctly and undamaged.

<b>2</b>	<b>ABS warning light does not illuminate</b>
<b>DESCRIPTION</b>	<ul style="list-style-type: none"> <li>ABS warning light does not illuminate with ignition switch on.</li> </ul>
<b>POSSIBLE CAUSE</b>	<ul style="list-style-type: none"> <li>ABS warning light circuit open circuit or shorted to ground.</li> </ul>
<p>INSTRUMENT CLUSTER CONNECTOR (16-PIN)</p> <p>(VIEW FROM HARNESS SIDE)</p>	

### Diagnostic procedure

STEP	INSPECTION	ACTION	
1	<b>CHECK FOR SHORT TO GROUND IN ABS HU/CM</b> <ul style="list-style-type: none"> <li>Disconnect ABS HU/CM connector and turn ignition switch on.</li> <li>Does ABS warning light illuminate?</li> </ul>	Yes	Replace ABS HU/CM (short to ground in ABS HU/CM).
		No	Go to next step.
2	<b>INSPECT ABS WARNING LIGHT BULB</b> <ul style="list-style-type: none"> <li>Remove instrument cluster.</li> <li>Inspect ABS warning light bulb.</li> <li>Is it okay?</li> </ul>	Yes	Go to next step.
		No	Replace ABS warning light bulb.

## SYMPTOM TROUBLESHOOTING

STEP	INSPECTION	ACTION	
*3	<b>CHECK TO SEE WHETHER MALFUNCTION IS IN WIRING HARNESS (SHORT TO GROUND BETWEEN INSTRUMENT CLUSTER AND ABS HU/CM) OR INSTRUMENT CLUSTER (OPEN CIRCUIT OR SHORT TO GROUND)</b> <ul style="list-style-type: none"> <li>Is there continuity between instrument cluster connector (16-pin) terminal 2B and ground?</li> </ul>	Yes	Repair wiring harness between instrument cluster and ABS HU/CM.
		No	Replace instrument cluster (open circuit or short to ground in ABS HU/CM).

### NO.3 BRAKE SYSTEM WARNING LIGHT DOES NOT ILLUMINATE

A3U040343000W07

04-03

- When performing an asterisked (\*) troubleshooting inspection, shake the wiring harness and connectors while performing the inspection to discover whether poor contact points are the cause of any intermittent malfunctions. If there is a problem, check to make sure connectors, terminals and wiring harness are connected correctly and undamaged.

3	BRAKE system warning light does not illuminate
<b>DESCRIPTION</b>	<ul style="list-style-type: none"> <li>BRAKE system warning light does not illuminate with ignition switch on.</li> </ul>
<b>POSSIBLE CAUSE</b>	<ul style="list-style-type: none"> <li>Open circuit or short to ground in BRAKE system warning light circuit.</li> </ul>
<p>INSTRUMENT CLUSTER CONNECTOR (18-PIN)</p> <p>(VIEW FROM HARNESS SIDE)</p>	

### Diagnostic procedure

STEP	INSPECTION	ACTION	
1	<b>CHECK FOR SHORT TO GROUND IN ABS HU/CM</b> <ul style="list-style-type: none"> <li>Disconnect ABS HU/CM connector and turn ignition switch on.</li> <li>Does BRAKE system warning light illuminate?</li> </ul>	Yes	Replace ABS HU/CM (short to ground in ABS HU/CM).
		No	Go to next step.
2	<b>INSPECT BRAKE SYSTEM WARNING LIGHT BULB</b> <ul style="list-style-type: none"> <li>Remove instrument cluster.</li> <li>Inspect BRAKE system warning light bulb.</li> <li>Is it okay?</li> </ul>	Yes	Go to next step.
		No	Replace BRAKE system warning light bulb.
*3	<b>CHECK TO SEE WHETHER MALFUNCTION IS IN WIRING HARNESS (SHORT TO GROUND BETWEEN INSTRUMENT CLUSTER AND ABS HU/CM) OR INSTRUMENT CLUSTER (OPEN OR SHORT TO GROUND)</b> <ul style="list-style-type: none"> <li>Is there continuity between instrument cluster connector (18-pin) terminal 1G and ground?</li> </ul>	Yes	Repair wiring harness between instrument cluster and ABS HU/CM.
		No	Replace instrument cluster (open circuit or short to ground in ABS HU/CM).

## SYMPTOM TROUBLESHOOTING

### NO.4 ABS WARNING LIGHT AND BRAKE SYSTEM WARNING LIGHT STAY ON

A3U040343000W08

- When performing an asterisked (\*) troubleshooting inspection, shake the wiring harness and connectors while performing the inspection to discover whether poor contact points are the cause of any intermittent malfunctions. If there is a problem, check to make sure connectors, terminals and wiring harness are connected correctly and undamaged.

<b>4</b>	<b>ABS warning light and BRAKE system warning light stay ON</b>
<b>DESCRIPTION</b>	<ul style="list-style-type: none"> <li>Both ABS warning light and BRAKE system warning light stay on <b>more than 4 seconds</b> with ignition switch on.</li> </ul>
<b>POSSIBLE CAUSE</b>	<ul style="list-style-type: none"> <li>ABS HU/CM detects ABS proportioning system malfunction</li> <li>ABS HU/CM detects low voltage in power supply (ABS HU/CM ignition terminal Z voltage is <b>below about 8 to 9 V</b>)</li> <li>ABS HU/CM does not operate</li> <li>Both warning light circuits (ABS and BRAKE system) open circuit or shorted to ground</li> </ul>

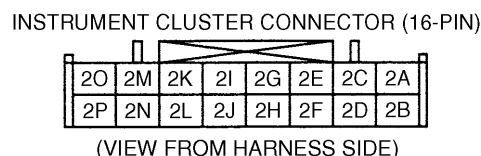
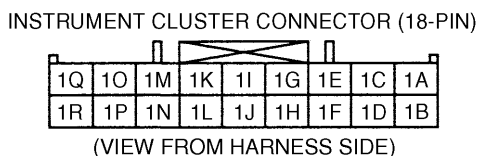
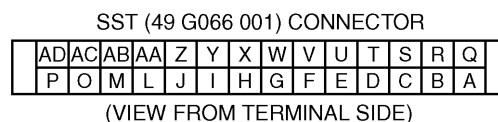
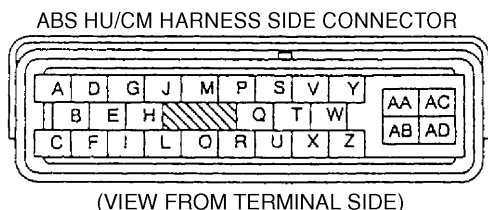

#### Diagnostic procedure

STEP	INSPECTION	ACTION	
1	<b>INSPECT ABS HU/CM POWER SUPPLY FUSE</b> <ul style="list-style-type: none"> <li>Is ABS HU/CM ignition power supply fuse okay?</li> </ul>	Yes	Go to next step.
		No	Check for a short to ground on blown fuse's circuit. Repair or replace as necessary. Install appropriate amperage fuse.
2	<b>INSPECT WIRING HARNESS BETWEEN ABS CM AND DLC-2 FOR CONTINUITY OR SHORTS</b> <ul style="list-style-type: none"> <li>Perform DTC inspection.</li> <li>Is error message displayed regarding communication between ABS HU/CM and WDS or equivalent?</li> </ul>	Yes	If a communication error message is displayed even after inspecting according to procedures displayed on the WDS or equivalent, go to Step 8.
		No	Go to next step.
3	<b>CHECK FOR DTCS IN ABS HU/CM</b> <ul style="list-style-type: none"> <li>Have DTCS been recorded in memory?</li> </ul>	Yes	Perform inspection using appropriate DTC.
		No	Go to next step.
4	<b>INSPECT PID/DATA IN ABS HU/CM</b> <ul style="list-style-type: none"> <li>Inspect the following items using WDS or equivalent.                             <ul style="list-style-type: none"> <li>— <b>ABS_LAMP</b> (ABS warning light)</li> <li>— <b>BRAKE_LMP</b> (BRAKE system warning light)</li> <li>— <b>ABS_VOLT</b> (power supply voltage)</li> </ul> </li> <li>Is <b>ABS_LAMP</b> and <b>BRAKE_LMP</b> ON after <b>more than 4 seconds</b> with ignition switch on?</li> </ul>	Yes	Go to Step 7.
		No	Go to next step.
5	<b>CHECK FOR OPEN CIRCUITS IN ABS HU/CM</b> <ul style="list-style-type: none"> <li>Disconnect ABS HU/CM. Connect the <b>SST</b> (49 G066 001) (vehicle harness side only).</li> <li>Use the <b>SST</b> connector to ground the warning light terminal (ABS: terminal W, BRAKE system: terminal X) to body ground.</li> <li>Do both ABS warning light and BRAKE system warning light go out with ignition switch on?</li> </ul>	Yes	Replace ABS HU/CM (open circuit in ABS HU/CM).
		No	Go to next step.

## SYMPTOM TROUBLESHOOTING

STEP	INSPECTION	ACTION	
*6	<b>CHECK TO SEE WHETHER MALFUNCTION IS IN WIRING HARNESS (LACK OF CONTINUITY BETWEEN INSTRUMENT CLUSTER AND ABS HU/CM) OR INSTRUMENT CLUSTER (OPEN CIRCUIT OR SHORT TO GROUND)</b> <ul style="list-style-type: none"> <li>• Disconnect instrument cluster connector.</li> <li>• Is there continuity between following ABS HU/CM connector terminals and instrument cluster connector terminals?                             <ul style="list-style-type: none"> <li>— Terminal W and terminal 2B (16-pin)</li> <li>— Terminal X and terminal 1G (18-pin)</li> </ul> </li> </ul>	Yes	Replace instrument cluster (open circuit or short to ground in instrument cluster).
		No	Repair wiring harness between ABS HU/CM (ABS: terminal W, BRAKE system: terminal X) and instrument cluster.
7	<b>INSPECT ABS HU/CM IGNITION POWER SUPPLY SYSTEM (TERMINAL Z)</b> <ul style="list-style-type: none"> <li>• Check the voltage for PID/DATA monitor <b>ABS_VOLT</b> item. <b>Specification: above 10 V</b></li> <li>• Is voltage within specification?</li> </ul>	Yes	Replace ABS HU/CM (open circuit or short in ground circuit in ABS HU/CM).
		No	Go to next step.
8	<b>INSPECT BATTERY</b> <ul style="list-style-type: none"> <li>• Is battery voltage normal?</li> </ul>	Yes	Go to next step.
		No	Inspect battery and charging system.
9	<b>INSPECT CHARGING SYSTEM</b> <ul style="list-style-type: none"> <li>• Is battery voltage normal with electrical load (A/C, headlights, etc.) on and engine idling?</li> </ul>	Yes	Go to next step.
		No	Inspect charging system (drive belt tension, generator, etc.).
10	<b>VERIFY THAT ABS HU/CM CONNECTOR IS CONNECTED WITH ABS HU/CM</b> <ul style="list-style-type: none"> <li>• Is ABS HU/CM securely connected?</li> </ul>	Yes	Go to Step 12.
		No	Connect ABS HU/CM connector securely, then go to next step.
11	<b>CONFIRM THAT MALFUNCTION SYMPTOM DO NOT REOCCUR AFTER ABS HU/CM IS CONNECTED</b> <ul style="list-style-type: none"> <li>• Do both ABS warning light and BRAKE system warning lights go out after <b>more than 4 seconds</b> with ignition switch on?</li> </ul>	Yes	Temporary poor connection in ABS HU/CM connector. Inspect connector and terminal.
		No	Go to next step.
12	<b>VERIFY THAT ABS HU/CM CONNECTOR TERMINALS Z AND AA ARE CONNECTED</b> <ul style="list-style-type: none"> <li>• Does malfunction symptom happen again when ABS HU/CM connector terminals Z and AA are shaken while the ignition switch is ON?</li> </ul>	Yes	Connect ABS HU/CM connector terminals Z and AA securely, then go to next step.
		No	Go to Step 14.
13	<b>CONFIRM THAT MALFUNCTION SYMPTOM DO NOT REOCCUR AFTER ABS HU/CM CONNECTOR TERMINALS Z AND AA ARE CONNECTED</b> <ul style="list-style-type: none"> <li>• Do both ABS warning light and BRAKE system warning lights go out after <b>more than 4 seconds</b> with ignition switch on?</li> </ul>	Yes	Temporary poor connection at terminal. Inspect ABS HU/CM connector and terminal.
		No	Go to next step.
*14	<b>INSPECT WIRING HARNESS BETWEEN ABS HU/CM POWER SUPPLY AND ABS HU/CM FOR CONTINUITY</b> <ul style="list-style-type: none"> <li>• Disconnect ABS HU/CM connector. Connect the <b>SST</b> (49 G066 001) (vehicle harness side only).</li> <li>• Is voltage <b>approximately 12 V</b> at <b>SST</b> connector terminal Z?</li> </ul>	Yes	Go to next step.
		No	Repair wiring harness between fuse block and ABS HU/CM.
*15	<b>INSPECT WIRING HARNESS BETWEEN ABS HU/CM AND GROUND FOR CONTINUITY</b> <ul style="list-style-type: none"> <li>• Turn ignition switch to LOCK.</li> <li>• Is there continuity between <b>SST</b> connector terminal AA and ground?</li> </ul>	Yes	If a communication error message is displayed on WDS or equivalent in Step 1 inspection, go to next step. If a communication error message is not displayed on WDS or equivalent in Step 1 inspection, troubleshooting is completed.
		No	Repair wiring harness between ABS HU/CM and ground.
*16	<b>INSPECT WIRING HARNESS BETWEEN ABS HU/CM AND DLC-2 FOR CONTINUITY</b> <ul style="list-style-type: none"> <li>• Is there continuity between <b>SST</b> connector terminal T and DLC-2?</li> </ul>	Yes	Go to next step.
		No	Repair wiring harness between ABS HU/CM and DLC-2.

## SYMPTOM TROUBLESHOOTING

STEP	INSPECTION	ACTION	
*17	<b>INSPECT WIRING HARNESS BETWEEN ABS HU/CM AND DLC-2 FOR SHORT TO B+</b> <ul style="list-style-type: none"> <li>Is voltage <b>approximately 12 V</b> at <b>SST</b> connector terminal T?</li> </ul>	Yes	Repair wiring harness between ABS HU/CM and DLC-2.
		No	Go to next step.
*18	<b>INSPECT WIRING HARNESS BETWEEN ABS HU/CM AND DLC-2 FOR SHORT TO GROUND</b> <ul style="list-style-type: none"> <li>Is there continuity between <b>SST</b> connector terminal T and ground?</li> </ul>	Yes	Repair wiring harness between ABS HU/CM and DLC-2.
		No	Replace ABS HU/CM (communication circuit malfunction in ABS HU/CM).

### NO.5 ABS WARNING LIGHT STAYS ON

A3U040343000W09

- When performing an asterisked (\*) troubleshooting inspection, shake the wiring harness and connectors while performing the inspection to discover whether poor contact points are the cause of any intermittent malfunctions. If there is a problem, check to make sure connectors, terminals and wiring harness are connected correctly and undamaged.

5	ABS warning light stays ON
<b>DESCRIPTION</b>	<ul style="list-style-type: none"> <li>ABS warning light stays on <b>more than 4 seconds</b> with ignition switch on.</li> </ul>
<b>POSSIBLE CAUSE</b>	<ul style="list-style-type: none"> <li>ABS HU/CM detects ABS system malfunction</li> <li>ABS HU/CM detects low voltage in power supply (ABS HU/CM ignition terminal Z voltage is <b>below about 8 to 9 V</b>)</li> <li>Warning light circuit open or shorted to ground</li> </ul>

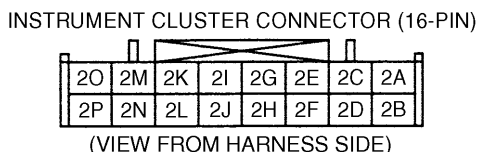
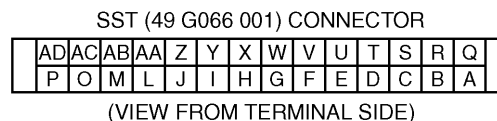
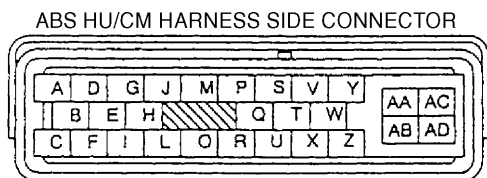

### Diagnostic procedure

STEP	INSPECTION	ACTION	
1	<b>INSPECT WIRING HARNESS BETWEEN ABS HU/CM AND DLC-2 FOR CONTINUITY AND SHORTS</b> <ul style="list-style-type: none"> <li>Perform DTC inspection.</li> <li>Is error message displayed regarding communication between ABS HU/CM and WDS or equivalent?</li> </ul>	Yes	If the communication error message is displayed even after inspecting according to procedures displayed on the WDS or equivalent, go to Step 8.
		No	Go to next step.
2	<b>CHECK FOR DTCS IN ABS HU/CM</b> <ul style="list-style-type: none"> <li>Have DTCs been recorded in memory?</li> </ul>	Yes	Perform inspection using appropriate DTC.
		No	Go to next step.
3	<b>INSPECT PID/DATA IN ABS HU/CM</b> <ul style="list-style-type: none"> <li>Inspect the following items using WDS or equivalent. — <b>ABS_LAMP</b> (ABS warning light)</li> <li>Is <b>ABS_LAMP</b> ON after <b>more than 4 seconds</b> with ignition switch on?</li> </ul>	Yes	Go to Step 8.
		No	Go to next step.
4	<b>VERIFY THAT ABS HU/CM CONNECTOR TERMINAL W IS CONNECTED</b> <ul style="list-style-type: none"> <li>Does malfunction symptom happen again when ABS HU/CM connector terminal W is shaken while the ignition switch is ON?</li> </ul>	Yes	Connect ABS HU/CM connector terminal W securely, then go to next step.
		No	Go to Step 6.

## SYMPTOM TROUBLESHOOTING

STEP	INSPECTION	ACTION	
5	<b>CONFIRM THAT MALFUNCTION SYMPTOM DO NOT REOCCUR AFTER ABS HU/CM CONNECTOR TERMINAL W IS CONNECTED</b> <ul style="list-style-type: none"> <li>Do ABS warning light go out after <b>more than 4 seconds</b> with ignition switch on?</li> </ul>	Yes	Temporary poor connection at terminal. Inspect ABS HU/CM connector and terminal.
		No	Go to next step.
6	<b>CHECK FOR OPEN CIRCUITS IN ABS HU/CM</b> <ul style="list-style-type: none"> <li>Disconnect ABS HU/CM. Connect the <b>SST</b> (49 G066 001) (vehicle harness side only).</li> <li>Use the <b>SST</b> connector to ground ABS warning light terminal W to body ground. Does ABS warning light go out with ignition switch on?</li> </ul>	Yes	Replace ABS HU/CM (open circuit in ABS HU/CM).
		No	Go to next step.
*7	<b>CHECK TO SEE WHETHER MALFUNCTION IS IN WIRING HARNESS (LACK OF CONTINUITY BETWEEN INSTRUMENT CLUSTER AND ABS HU/CM) OR INSTRUMENT CLUSTER (OPEN CIRCUIT OR SHORT TO GROUND)</b> <ul style="list-style-type: none"> <li>Disconnect instrument cluster.</li> <li>Is there continuity between following <b>SST</b> connector terminal W and instrument cluster connector (16-pin) terminal 2B?</li> </ul>	Yes	Replace instrument cluster (open circuit or ground to short in instrument cluster).
		No	Repair wiring harness between ABS HU/CM (terminal W) and instrument cluster.
8	<b>INSPECT ABS HU/CM IGNITION POWER SUPPLY SYSTEM (TERMINAL Z)</b> <ul style="list-style-type: none"> <li>Check the voltage for PID/DATA monitor <b>ABS_VOLT</b> item. <b>Specification: above 10V</b></li> <li>Is voltage within specification?</li> </ul>	Yes	Replace ABS HU/CM (open circuit or short in ground circuit in ABS HU/CM).
		No	Go to next step.
9	<b>INSPECT BATTERY</b> <ul style="list-style-type: none"> <li>Is battery voltage normal?</li> </ul>	Yes	Go to next step
		No	Inspect battery and charging system
10	<b>INSPECT CHARGING SYSTEM</b> <ul style="list-style-type: none"> <li>Is battery voltage normal with electrical load (A/C, headlights, etc) on and engine idling?</li> </ul>	Yes	Go to next step
		No	Inspect charging system (drive belt tension, generator, etc).
*11	<b>INSPECT WIRING HARNESS BETWEEN ABS HU/CM POWER SUPPLY AND ABS HU/CM FOR CONTINUITY</b> <ul style="list-style-type: none"> <li>Disconnect ABS HU/CM. Connect <b>SST</b> (49 G066 001) (vehicle harness side only).</li> <li>Is voltage <b>approximately 12V</b> at <b>SST</b> connector terminal Z?</li> </ul>	Yes	Go to next step.
		No	Repair wiring harness between fuse block and ABS HU/CM
*12	<b>INSPECT WIRING HARNESS BETWEEN ABS HU/CM AND GROUND FOR CONTINUITY</b> <ul style="list-style-type: none"> <li>Turn ignition switch to LOCK</li> <li>Is there continuity between <b>SST</b> connector terminal AA and ground?</li> </ul>	Yes	If a communication error message is displayed on WDS or equivalent in Step 1 inspection, go to next step. If a communication error message is not displayed on WDS or equivalent in Step 1 inspection, trouble shooting is completed.
		No	Repair wiring harness between ABS HU/CM and ground.
*13	<b>INSPECT WIRING HARNESS BETWEEN ABS HU/CM AND DLC-2 FOR CONTINUITY</b> <ul style="list-style-type: none"> <li>Disconnect ABS HU/CM. Connect the <b>SST</b> (49 G066 001) (vehicle harness side only).</li> <li>Is there continuity between <b>SST</b> connector terminal T and DLC-2?</li> </ul>	Yes	Go to next step.
		No	Repair wiring harness between ABS HU/CM and DLC-2.
*14	<b>INSPECT WIRING HARNESS BETWEEN ABS HU/CM AND DLC-2 FOR SHORT TO B+</b> <ul style="list-style-type: none"> <li>Is voltage <b>approximately 12 V</b> at <b>SST</b> connector terminal T?</li> </ul>	Yes	Repair wiring harness between ABS HU/CM and DLC-2.
		No	Go to next step.
*15	<b>INSPECT WIRING HARNESS BETWEEN ABS HU/CM AND DLC-2 FOR SHORT TO GROUND</b> <ul style="list-style-type: none"> <li>Is there continuity between <b>SST</b> connector terminal T and ground?</li> </ul>	Yes	Repair wiring harness between ABS HU/CM and DLC-2.
		No	Replace ABS HU/CM (communication circuit malfunction in ABS HU/CM).



## SYMPTOM TROUBLESHOOTING

A3U040343000W10

### NO.6 BRAKE SYSTEM WARNING LIGHT STAYS ON

- When performing an asterisked (\*) troubleshooting inspection, shake the wiring harness and connectors while performing the inspection to discover whether poor contact points are the cause of any intermittent malfunctions. If there is a problem, check to make sure connectors, terminals and wiring harness are connected correctly and undamaged.

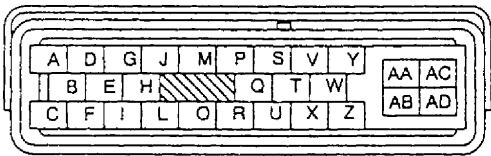
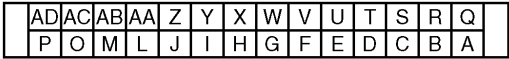
<b>6</b>	<b>BRAKE system warning light stays ON</b>
<b>DESCRIPTION</b>	<ul style="list-style-type: none"> <li>Brake system warning light stays on <b>more than 4 seconds</b> with ignition switch on. (Parking brake is released.)</li> </ul>
<b>POSSIBLE CAUSE</b>	<ul style="list-style-type: none"> <li>Warning light circuit open or shorted to ground in ABS HU/CM</li> <li>Short to ground in circuit in parking brake switch and/or brake fluid level sensor</li> </ul>
<div style="display: flex; justify-content: space-around; align-items: flex-start;"> <div style="text-align: center;"> <p>ABS HU/CM HARNESS SIDE CONNECTOR</p>  <p>(VIEW FROM TERMINAL SIDE)</p> </div> <div style="text-align: center;"> <p>SST (49 G066 001) CONNECTOR</p>  <p>(VIEW FROM TERMINAL SIDE)</p> </div> </div>	

#### Diagnostic procedure

STEP	INSPECTION	ACTION	
1	<b>INSPECT BRAKE FLUID LEVEL</b> <ul style="list-style-type: none"> <li>Is brake fluid level okay?</li> </ul>	Yes	Go to next step.
		No	Add brake fluid.
2	<b>INSPECT WIRING HARNESS BETWEEN ABS HU/CM AND DLC-2 FOR CONTINUITY AND SHORTS</b> <ul style="list-style-type: none"> <li>Inspect the following items using WDS or equivalent.                             <ul style="list-style-type: none"> <li><b>BRAKE_LMP</b> (BRAKE system warning light)</li> </ul> </li> <li>Is error message displayed regarding communication between ABS HU/CM and WDS or equivalent?</li> </ul>	Yes	If a communication error message is displayed even after inspecting according to procedures displayed on the WDS or equivalent, go to Step 8.
		No	Go to next step.
3	<b>INSPECT PID/DATA IN ABS HU/CM</b> <ul style="list-style-type: none"> <li>Inspect <b>BRAKE_LMP</b> (BRAKE system warning light) using WDS or equivalent.</li> <li>Is <b>BRAKE_LMP</b> is ON after <b>more than 4 seconds</b> with ignition switch on?</li> </ul>	Yes	Replace ABS HU/CM (open circuit or short to ground in ABS HU/CM).
		No	Go to next step.
4	<b>VERIFY THAT ABS HU/CM CONNECTOR TERMINAL X IS CONNECTED</b> <ul style="list-style-type: none"> <li>Does malfunction symptom happen again when ABS HU/CM connector terminal X is shaken while the ignition switch is ON?.</li> </ul>	Yes	Connect ABS HU/CM connector terminal X securely, then go to next step.
		No	Go to Step 6.
5	<b>CONFIRM THAT MALFUNCTION SYMPTOMS DO NOT RECCUR AFTER ABS HU/CM CONNECTOR TERMINAL X IS CONNECTED</b> <ul style="list-style-type: none"> <li>Does BRAKE system warning light go out after <b>more than 4 seconds</b> with ignition switch on?</li> </ul>	Yes	Temporary poor connection at terminal. Inspect ABS HU/CM connector and terminal.
		No	Go to next step.
*6	<b>CHECK FOR OPEN CIRCUITS IN ABS HU/CM</b> <ul style="list-style-type: none"> <li>Disconnect ABS HU/CM. Connect the <b>SST</b> (49 G066 001) (vehicle harness side only).</li> <li>Use the <b>SST</b> connector to ground BRAKE system warning light terminal X to body ground.</li> <li>Does BRAKE system warning light go out with ignition switch on?</li> </ul>	Yes	Replace ABS HU/CM (open circuit in ABS HU/CM).
		No	Go to next step.

## SYMPTOM TROUBLESHOOTING

STEP	INSPECTION	ACTION	
7	<b>CHECK TO SEE WHETHER MALFUNCTION IS IN PARKING BRAKE SWITCH OR BRAKE FLUID LEVEL SENSOR, OR IN SOME OTHER PART</b> <ul style="list-style-type: none"> <li>Disconnect the following in order:                             <ol style="list-style-type: none"> <li>Parking brake switch connector</li> <li>Brake fluid level sensor connector</li> </ol> </li> <li>Does BRAKE system warning light go out with ignition switch on?</li> </ul>	Yes	Replace parking brake switch and/or brake fluid level sensor (shorted on some internal part).
		No	Perform the following inspections. Repair if necessary. <ul style="list-style-type: none"> <li>Open circuit in wiring harness between ABS HU/CM (terminal X) and instrument cluster (BRAKE system warning light)</li> <li>Short to ground in wiring harness between instrument cluster (BRAKE system warning light) and parking brake switch.</li> <li>Short to ground in wiring harness between instrument cluster (BRAKE system warning light) and brake fluid level sensor.</li> </ul> If above inspections are okay, replace instrument cluster (open or ground to short in instrument cluster).
*8	<b>INSPECT WIRING HARNESS BETWEEN ABS HU/CM AND DLC-2 FOR CONTINUITY</b> <ul style="list-style-type: none"> <li>Disconnect ABS HU/CM. Connect the <b>SST</b> (49 G066 001) (vehicle harness side only).</li> <li>Is there continuity between <b>SST</b> connector terminal T and DLC-2?</li> </ul>	Yes	Go to next step.
		No	Repair wiring harness between ABS HU/CM and DLC-2.
*9	<b>INSPECT WIRING HARNESS BETWEEN ABS HU/CM AND DLC-2 FOR SHORT TO B+</b> <ul style="list-style-type: none"> <li>Is voltage <b>approximately 12 V</b> at <b>SST</b> connector terminal T?</li> </ul>	Yes	Repair wiring harness between ABS HU/CM and DLC-2.
		No	Go to next step.
*10	<b>INSPECT WIRING HARNESS BETWEEN ABS HU/CM AND DLC-2 FOR SHORT TO GROUND</b> <ul style="list-style-type: none"> <li>Is there continuity between <b>SST</b> connector terminal T and ground?</li> </ul>	Yes	Repair wiring harness between ABS HU/CM and DLC-2.
		No	Replace ABS HU/CM (communication circuit malfunction in ABS HU/CM).

04-03

### NO.7 BRAKE SYSTEM MALFUNCTION

A3U040343000W11

7	BRAKE system malfunction
DESCRIPTION	<ul style="list-style-type: none"> <li>There is a malfunction in system even though ABS warning light and BRAKE system warning light does not illuminate.</li> </ul>
POSSIBLE CAUSE	<ul style="list-style-type: none"> <li>There is a mechanical malfunction in system</li> </ul>

#### Diagnostic procedure

STEP	INSPECTION	ACTION	
1	<b>CHECK FOR DTCS IN ABS HU/CM</b> <ul style="list-style-type: none"> <li>Have DTCS been recorded in memory?</li> </ul>	Yes	Perform inspection using appropriate DTC.
		No	Go to next step.
2	<b>INSPECT ABS HYDRAULIC UNIT</b> <ul style="list-style-type: none"> <li>Perform "ABS hydraulic unit system inspection".</li> <li>Is system okay?</li> </ul>	Yes	Inspect conventional brake system.
		No	<b>If wheels do not rotate:</b> <ul style="list-style-type: none"> <li>Replace ABS HU/CM.</li> </ul> <b>If wheels rotate but order in which wheels rotate is incorrect:</b> <ul style="list-style-type: none"> <li>Inspect brake pipe passage to ABS HU/CM.</li> </ul>

## 04-10 GENERAL PROCEDURES

<b>PRECAUTION (BRAKES)</b> .....	<b>04-10-1</b>	Connectors Disconnection .....	<b>04-10-1</b>
Wheels and Tires Removal/Installation	<b>04-10-1</b>	ABS Components Operations.....	<b>04-10-1</b>
Brake Lines Disconnection/Connection	<b>04-10-1</b>		

### PRECAUTION (BRAKES)

A3U041001020W01

#### Wheels and Tires Removal/Installation

1. The removal and installation procedures for the wheels and tires are not mentioned in this section. When a wheel is removed, tighten it to **89—117 N·m {9.0—12.0 kgf·m, 65.1—86.7 ft·lbf}**.

#### Brake Lines Disconnection/Connection

##### Caution

- **Brake fluid will damage painted surfaces. If brake fluid does get on a painted surface, wipe it off immediately.**

1. Tighten the brake pipe flare nut using the **SST** (49 0259 770B). Be sure to modify the brake pipe flare nut tightening torque to allow for use of a torque wrench-**SST** combination. (See 00-00-15 Torque Formulas.)
  - If any brake line has been disconnected anytime during the procedure, add brake fluid, bleed the brakes, and inspect for leakage after the procedure has been completed.

#### Connectors Disconnection

1. Disconnect the negative battery cable before doing any work that requires handling of connectors. Reconnect the negative battery cable only after the work is completed.

#### ABS Components Operations

1. Make sure that there are no DTCs in the ABS memory after working on ABS components.
  - If there are any DTCs in the memory, clear them.

04-10

**04-11 CONVENTIONAL BRAKE SYSTEM**

<b>CONVENTIONAL BRAKE SYSTEM</b>		<b>FRONT BRAKE (DISC) INSPECTION . . .</b>	<b>04-11-14</b>
<b>LOCATION INDEX . . . . .</b>	<b>04-11-2</b>	Brake Judder Repair Hint . . . . .	<b>04-11-14</b>
<b>AIR BLEEDING . . . . .</b>	<b>04-11-3</b>	Disc Plate Thickness Inspection . . . . .	<b>04-11-16</b>
<b>VACUUM HOSE CHECK VALVE</b>		Disc Pad Thickness Inspection . . . . .	<b>04-11-16</b>
<b>INSPECTION (POWER BRAKE UNIT) .</b>	<b>04-11-3</b>	<b>FRONT BRAKE (DISC)</b>	
<b>BRAKE PEDAL INSPECTION . . . . .</b>	<b>04-11-3</b>	<b>REMOVAL/INSTALLATION . . . . .</b>	<b>04-11-17</b>
Brake Pedal Height Inspection . . . . .	<b>04-11-3</b>	Disc Plate Removal Note . . . . .	<b>04-11-18</b>
Brake Pedal Height Adjustment . . . . .	<b>04-11-4</b>	Disc Plate Installation Note . . . . .	<b>04-11-18</b>
Brake Pedal Play Inspection . . . . .	<b>04-11-4</b>	Disc Pad Installation Note . . . . .	<b>04-11-18</b>
Brake Pedal Play Adjustment . . . . .	<b>04-11-4</b>	<b>DISC PAD (FRONT) REPLACEMENT . . .</b>	<b>04-11-19</b>
Pedal-to-floor Clearance Inspection . . .	<b>04-11-5</b>	<b>CALIPER (FRONT)</b>	
<b>BRAKE PEDAL</b>		<b>DISASSEMBLY/ASSEMBLY . . . . .</b>	<b>04-11-20</b>
<b>REMOVAL/INSTALLATION . . . . .</b>	<b>04-11-5</b>	Piston Disassembly Note . . . . .	<b>04-11-20</b>
<b>BRAKE SWITCH INSPECTION . . . . .</b>	<b>04-11-5</b>	Piston Seal Disassembly Note . . . . .	<b>04-11-20</b>
<b>MASTER CYLINDER</b>		Bleeder Screw Assembly Note . . . . .	<b>04-11-21</b>
<b>REMOVAL/INSTALLATION . . . . .</b>	<b>04-11-6</b>	<b>REAR BRAKE (DISC) INSPECTION . . .</b>	<b>04-11-21</b>
Master Cylinder Installation Note . . . .	<b>04-11-6</b>	Brake Judder Repair Hint . . . . .	<b>04-11-21</b>
<b>FLUID LEVEL SENSOR INSPECTION . .</b>	<b>04-11-9</b>	Disc Pad Thickness Inspection . . . . .	<b>04-11-21</b>
<b>MASTER CYLINDER</b>		Disc Plate Thickness Inspection . . . . .	<b>04-11-21</b>
<b>DISASSEMBLY/ASSEMBLY . . . . .</b>	<b>04-11-10</b>	<b>REAR BRAKE (DISC)</b>	
Stop Screw and O-ring (without ABS)		<b>REMOVAL/INSTALLATION . . . . .</b>	<b>04-11-22</b>
Assembly Note . . . . .	<b>04-11-11</b>	Disc Pad Installation Note . . . . .	<b>04-11-22</b>
Stop Pin and O-ring (with ABS)		<b>DISC PAD (REAR) REPLACEMENT . . .</b>	<b>04-11-23</b>
Assembly Note . . . . .	<b>04-11-11</b>	<b>CALIPER (REAR)</b>	
<b>POWER BRAKE UNIT INSPECTION . . .</b>	<b>04-11-11</b>	<b>DISASSEMBLY/ASSEMBLY . . . . .</b>	<b>04-11-24</b>
Power Brake Unit Function Check . . . .	<b>04-11-11</b>	Piston Disassembly Note . . . . .	<b>04-11-24</b>
<b>POWER BRAKE UNIT</b>		Piston Assembly Note . . . . .	<b>04-11-25</b>
<b>REMOVAL/INSTALLATION . . . . .</b>	<b>04-11-13</b>	<b>REAR BRAKE (DRUM) INSPECTION . . .</b>	<b>04-11-25</b>
<b>DUAL PROPORTIONING VALVE</b>		Brake Lining Thickness Inspection . . .	<b>04-11-25</b>
<b>(WITHOUT ABS) INSPECTION . . . . .</b>	<b>04-11-13</b>	Brake Drum Inspection . . . . .	<b>04-11-25</b>
<b>DUAL PROPORTIONING VALVE</b>		<b>REAR BRAKE (DRUM)</b>	
<b>(WITHOUT ABS) AND BRAKE PIPE</b>		<b>REMOVAL/INSTALLATION . . . . .</b>	<b>04-11-26</b>
<b>JOINT (WITH ABS) REPLACEMENT . .</b>	<b>04-11-14</b>	Brake Drum Removal Note . . . . .	<b>04-11-27</b>
Dual Proportioning Valve		Brake Drum Installation Note . . . . .	<b>04-11-27</b>
(Without ABS) or Brake Pipe Joint		<b>WHEEL CYLINDER</b>	
(With ABS) Installation Note . . . . .	<b>04-11-14</b>	<b>DISASSEMBLY/ASSEMBLY . . . . .</b>	<b>04-11-27</b>

04-11

# CONVENTIONAL BRAKE SYSTEM

## CONVENTIONAL BRAKE SYSTEM LOCATION INDEX

A3U041101020W01

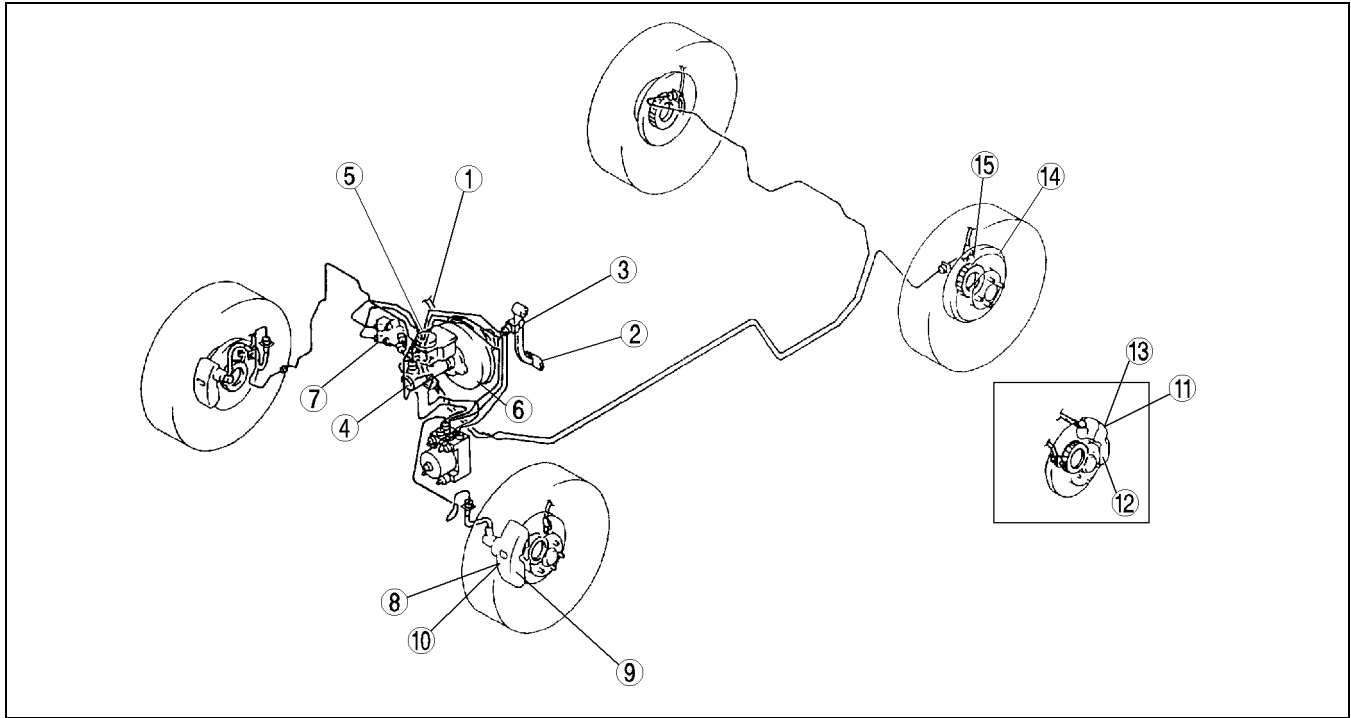

Z3U0411W101

1	Vacuum line (See 04-11-3 VACUUM HOSE CHECK VALVE INSPECTION (POWER BRAKE UNIT))
2	Brake pedal (See 04-11-3 BRAKE PEDAL INSPECTION) (See 04-11-5 BRAKE PEDAL REMOVAL/ INSTALLATION)
3	Brake switch (See 04-11-5 BRAKE SWITCH INSPECTION)
4	Master cylinder (See 04-11-6 MASTER CYLINDER REMOVAL/ INSTALLATION) (See 04-11-10 MASTER CYLINDER DISASSEMBLY/ASSEMBLY)
5	Brake fluid level sensor (See 04-11-9 FLUID LEVEL SENSOR INSPECTION)
6	Power brake unit (See 04-11-11 POWER BRAKE UNIT INSPECTION) (See 04-11-13 POWER BRAKE UNIT REMOVAL/ INSTALLATION)
7	Dual proportioning valve (without ABS) or brake pipe joint (with ABS) (See 04-11-13 DUAL PROPORTIONING VALVE (WITHOUT ABS) INSPECTION ) (See 04-11-14 DUAL PROPORTIONING VALVE (WITHOUT ABS) AND BRAKE PIPE JOINT (WITH ABS) REPLACEMENT )

8	Front brake (disc) (See 04-11-14 FRONT BRAKE (DISC) INSPECTION) (See 04-11-17 FRONT BRAKE (DISC) REMOVAL/ INSTALLATION)
9	Front disc pad (See 04-11-19 DISC PAD (FRONT) REPLACEMENT)
10	Front caliper (See 04-11-20 CALIPER (FRONT) DISASSEMBLY/ASSEMBLY)
11	Rear brake (disc) (See 04-11-21 REAR BRAKE (DISC) INSPECTION) (See 04-11-22 REAR BRAKE (DISC) REMOVAL/ INSTALLATION)
12	Rear disc pad (See 04-11-23 DISC PAD (REAR) REPLACEMENT)
13	Rear caliper (See 04-11-24 CALIPER (REAR) DISASSEMBLY/ ASSEMBLY)
14	Rear brake (drum) (See 04-11-25 REAR BRAKE (DRUM) INSPECTION) (See 04-11-26 REAR BRAKE (DRUM) REMOVAL/ INSTALLATION)
15	Wheel cylinder (See 04-11-27 WHEEL CYLINDER DISASSEMBLY/ASSEMBLY)

# CONVENTIONAL BRAKE SYSTEM

## AIR BLEEDING

A3U041143001W01

### Note

- The brakes should be bled whenever a brake line is disconnected. If a hydraulic line is disconnected at the master cylinder, start at the slave cylinder farthest from the brake master cylinder, and move to the next farthest slave cylinder until all 4 cylinders have been bled. If the disconnection point is anywhere except the master cylinder, start at the point closest to the disconnection, and move to the next closest slave cylinder until all 4 cylinders have been bled.

### Specified fluid

**SAEJ1703 or FMVSS 116 DOT-3**

- On level ground, jack up the vehicle and support it evenly on safety stands.
- Remove the bleeder cap and attach a vinyl tube to the bleeder screw.
- Place the other end of the vinyl tube in a clear, fluid filled container.
- The first person depresses the brake pedal a few times, and then holds it in the depressed position.
- The second person loosens the bleeder screw, drains out the fluid and closes the screw using the **SST**.
- Repeat Steps 4 and 5 until no air bubbles are seen. The reservoir should be kept **about 3/4** full during bleeding to prevent air from reentering the lines.

### Tightening torque

**5.9—8.8 N·m {60—90 kgf·cm, 53—78 in·lbf}**

- Inspect for correct brake operation.
- Verify that there is no fluid leakage. Wipe off any spilled fluid immediately.
- After bleeding the brakes, add brake fluid to the maximum level.

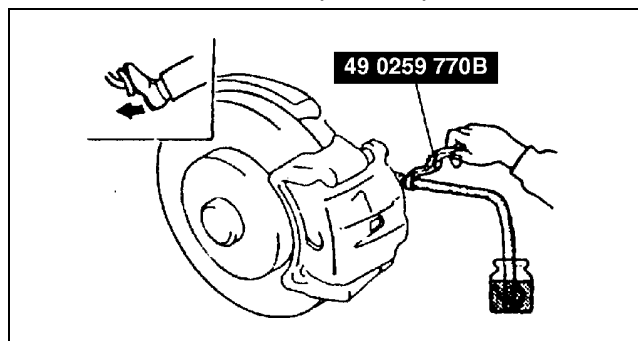

X3U411WA0

04-11

## VACUUM HOSE CHECK VALVE INSPECTION (POWER BRAKE UNIT)

A3U041143980W01

- Remove the clamps and vacuum hose.
- Apply both suction and pressure to the engine-side hose, and verify that air blows only toward that side.
  - If air flows in both directions or not at all, replace the vacuum hose.

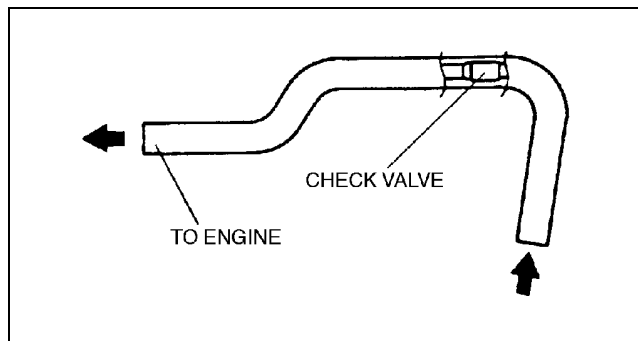

X3U411WA1

## BRAKE PEDAL INSPECTION

A3U041143300W01

### Brake Pedal Height Inspection

- Verify that the distance from the carpet to the center of the upper surface of the pedal pad is as specified.

### Pedal height (reference value)

**185 mm {7.28 in}**

# CONVENTIONAL BRAKE SYSTEM

## Brake Pedal Height Adjustment

1. Disconnect the brake switch connector.
2. Loosen locknut B and turn switch A until it does not contact the pedal.
3. Loosen locknut D and turn rod C to adjust the height.
4. Tighten the bolt with locknut B so that clearance between the bolt for brake light switch A and pedal stopper is within the specification.

### Specification

0.1—1.0 mm {0.004—0.039 in}

### Tightening torque

13.8—17.6 N·m {140—180 kgf·cm, 122—156 in·lbf}

5. Connect the brake switch connector.
6. After adjustment, inspect the pedal play and the brake light operation.

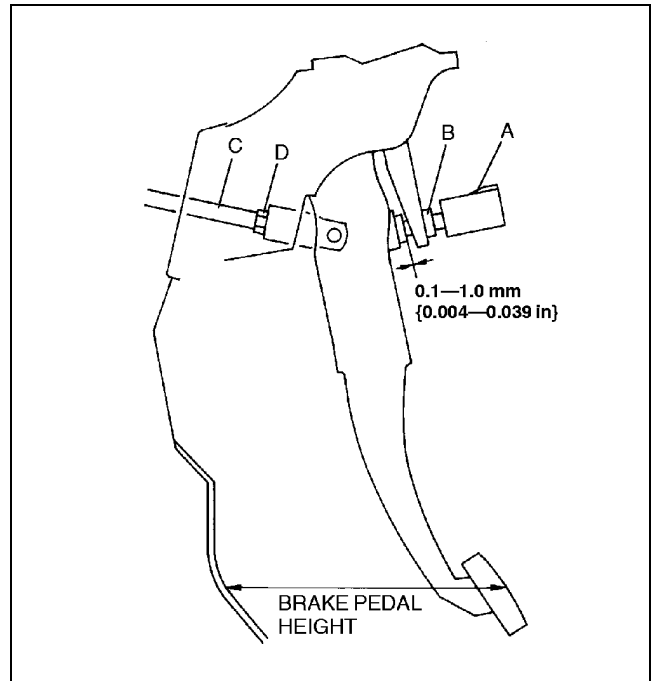

X3U411WA2

## Brake Pedal Play Inspection

1. Depress the pedal a few times to eliminate the vacuum in the system.
2. Remove the spring pin, verify that the holes in the fork and in the pedal are aligned, and reinstall the pin. (See 04-11-5 BRAKE PEDAL REMOVAL/INSTALLATION.)
3. Gently depress the pedal by hand until resistance is felt, and check the pedal play.

### Pedal play

4—12 mm {0.16—0.47 in}

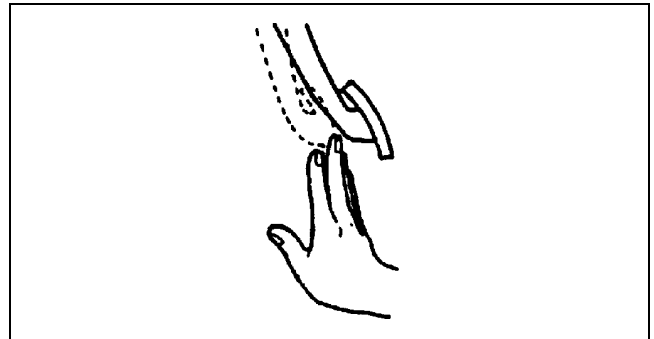

X3U411WA3

## Brake Pedal Play Adjustment

1. Remove the spring pin and clevis pin. (See 04-11-5 BRAKE PEDAL REMOVAL/INSTALLATION.)
2. Loosen locknut D and turn rod C to align the holes in the fork and in the pedal.
3. Install the clevis pin and the spring pin.
4. Tighten locknut D.

### Tightening torque

24—34 N·m {2.4—3.5 kgf·m, 18—25 ft·lbf}

5. Check the pedal height and the brake light operation.

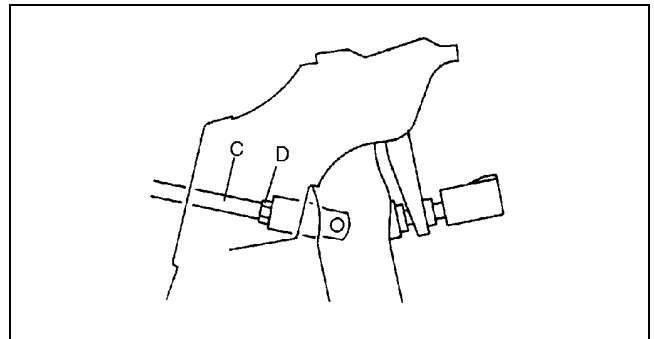

X3U411WA4

# CONVENTIONAL BRAKE SYSTEM

## Pedal-to-floor Clearance Inspection

1. Start the engine and depress the brake pedal with a force of **588 N {60 kgf, 132 lbf}**
2. Verify that the distance from the floor panel to the pedal pad center is as specified when the pedal is depressed.
  - If the distance is less than specified, check for the air in brake system.

### Specification

**ZM : 88 mm {3.5 in} min.**

**FS : 84 mm {3.3 in} min.**

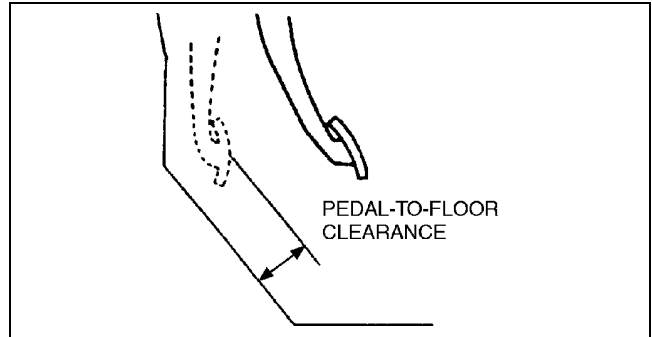

X3U411WA5

04-11

## BRAKE PEDAL REMOVAL/INSTALLATION

1. Remove in the order indicated in the table.

1	Brake switch connector
2	Spring pin
3	Clevis pin
4	Brake pedal
5	Brake switch
6	Pedal pad

2. Install in the reverse order of removal.

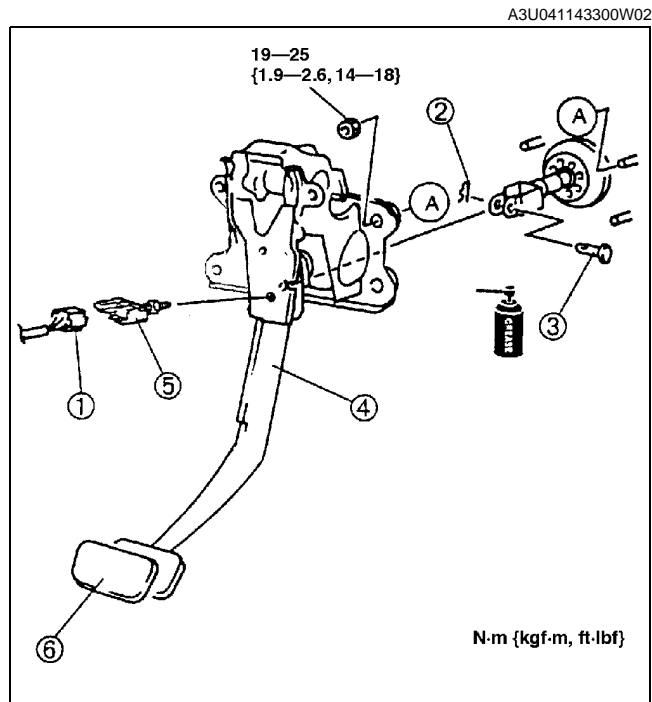

X3U411WA6

## BRAKE SWITCH INSPECTION

1. Disconnect the brake switch connector.
2. Inspect for continuity between the terminals of the brake switch connector using the ohmmeter.
  - If not as specified, replace the brake switch.

○—○ : Continuity

Condition	Terminal			
	A	B	C	D
Brake pedal is depressed	○—○			
Brake pedal is not depressed			○—○	

Y3U411WA8

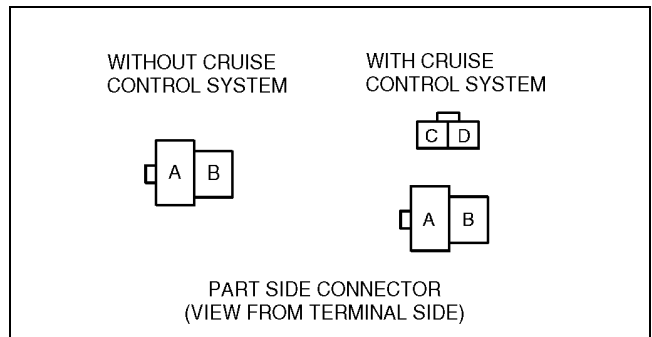

A3U0411W001



# CONVENTIONAL BRAKE SYSTEM

## MASTER CYLINDER REMOVAL/INSTALLATION

A3U041143400W01

1. Remove in the order indicated in the table.

1	Brake fluid level sensor connector
2	Brake pipe
3	Hose (MTX)
4	Master cylinder (See 04-11-6 Master Cylinder Installation Note)

2. Install in the reverse order of removal.

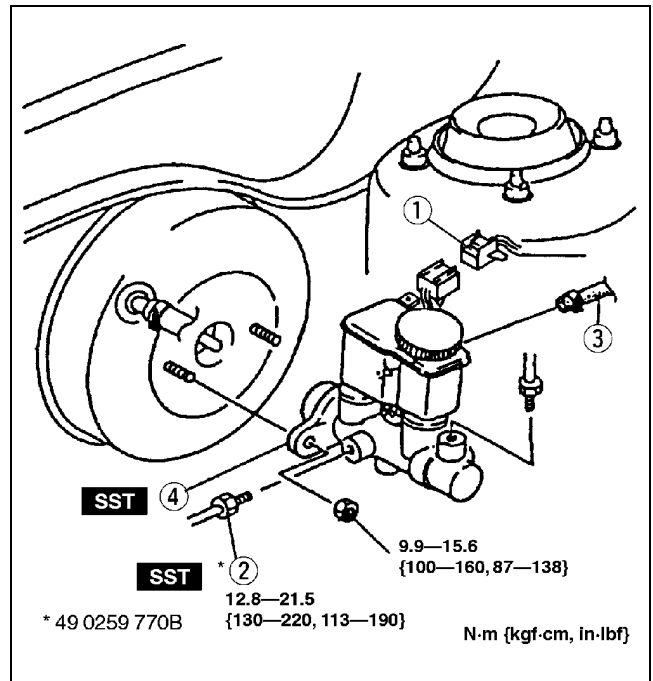

X3U411WA9

### Master Cylinder Installation Note

#### FS

1. Turn the nut of the **SST** clockwise to fully retract the **SST** gauge rod. Attach the **SST** to the power brake unit.

#### Tightening torque

9.9—15 N·m {1.0—1.6 kgf·m, 7.3—11 ft·lbf}

2. Apply a **66.7 kPa {500 mmHg, 19.7 inHg}** vacuum by using a vacuum pump.

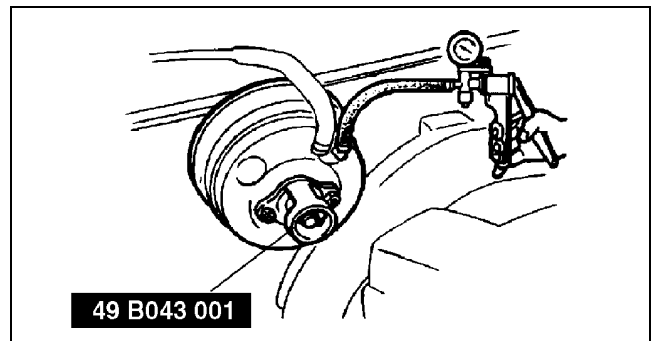

Z5U0411W130

- Turn the adjusting nut of the **SST** counterclockwise until the gauge rod just contacts the push rod end of the power brake unit. Push lightly on the end of the gauge rod to be sure it is seated. Verify that there is no gap between the adjusting nut and **SST** body.
- Remove the **SST** from the power brake unit without disturbing the adjusting nut. Set the **SST** onto the master cylinder as shown in the figure.

#### Caution

- When pushing the **SST** gauge rod into the master cylinder piston, only use enough pressure to push the rod to the bottom of the piston. If too much pressure is applied, a false reading will occur.

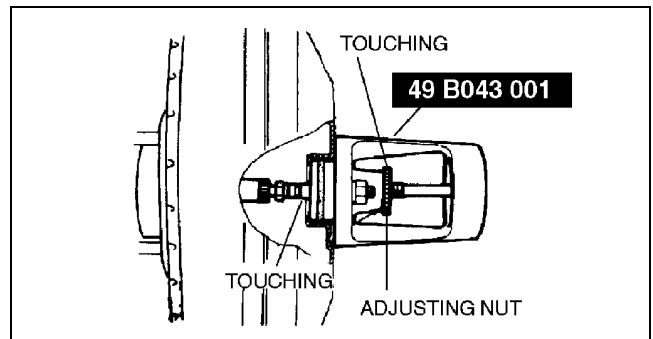

Z5U0411W131

# CONVENTIONAL BRAKE SYSTEM

5. Push lightly on the end of the **SST** gauge rod to be sure it has contacted the bottom of the master cylinder piston, but do not push so hard that the piston moves. Note any clearance between the **SST** body and the adjusting nut (clearance B) or between the body and the master cylinder (clearance C).

Measurement	Push rod
Clearance at (B)	Too short
Clearance at (C)	Too long
No clearance at (B) or (C)	

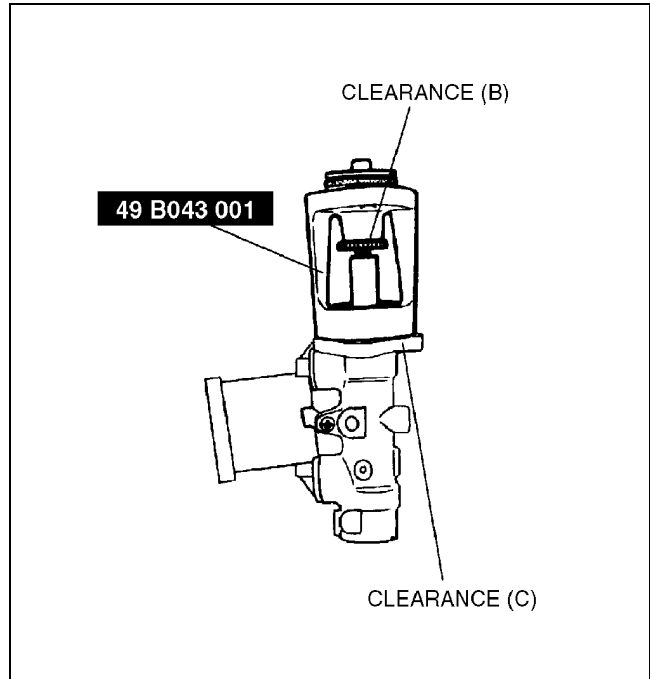

Z5U0411W132

04-11

## Adjusting the push rod clearance at B

### Note

- The threads of the push rod are specially designed so that the bolt becomes harder to turn past a certain point. This is to prevent the bolt from coming loose. Turn the bolt only within this range when adjusting.

1. Push lightly on the end of the **SST** gauge rod, and measure the clearance between the adjusting nut and the **SST** body.

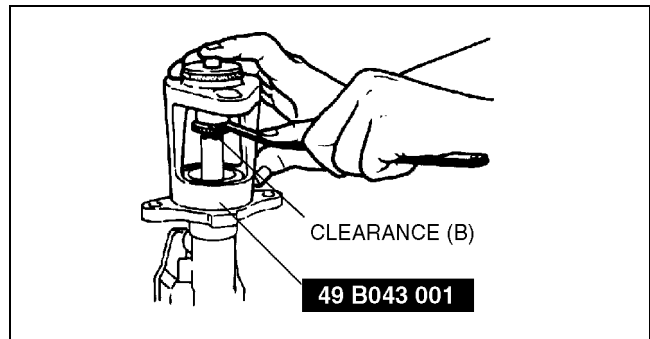

Z5U0411W133

2. Using the **SST**, turn the nut to lengthen the power brake unit push rod an amount equal to the sum subtracting **0.1—0.4 mm {0.004—0.016 in}** from the clearance measured at B.

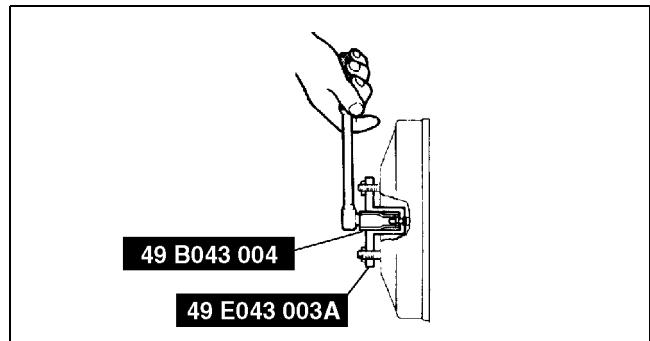

Z5U0411W134

# CONVENTIONAL BRAKE SYSTEM

## Adjusting the push rod clearance at C or no clearance at B or C

### Note

- The threads of the push rod are specially designed so that the bolt becomes harder to turn past a certain point. This is to prevent the bolt from coming loose. Turn the bolt only within this range when adjusting.

1. Measure and record height D1 of the gauge rod.
2. Turn the adjusting nut until the **SST** body sets evenly on the master cylinder. (Turn only enough for the body to touch.)

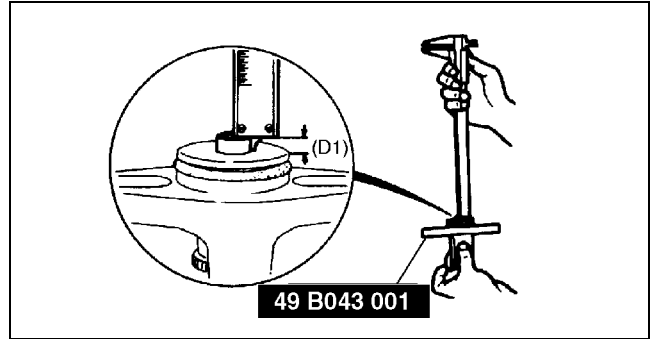

Z5U0411W135

3. Measure and record height D2 of the gauge rod.

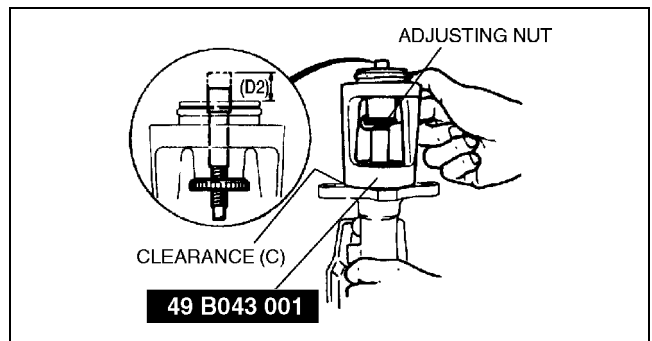

Z5U0411W136

4. Subtract D1 from D2 and add **0.1—0.4 mm {0.004—0.016 in}**. Using the **SST**, turn the nut to shorten the power booster push rod an amount equal to the sum.

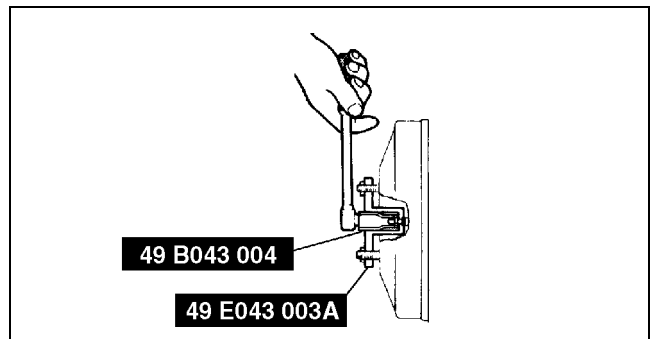

Z5U0411W134

### ZM

1. Place the **SST** atop the master cylinder. Turn the adjusting bolt until it touches the bottom of the push rod hole in the piston.
2. Apply **66.7 kPa {500 mmHg, 19.7 inHg}** vacuum to the power brake unit using a vacuum pump.

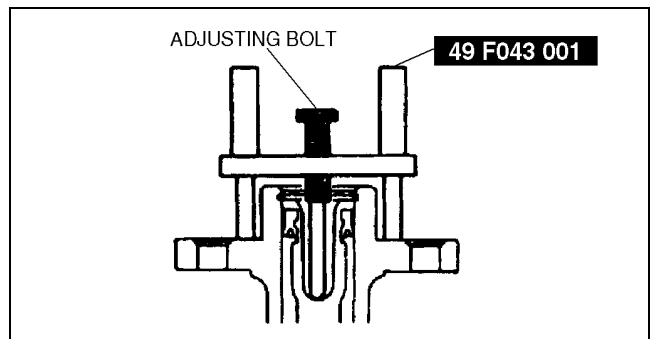

X3U411WAA

## CONVENTIONAL BRAKE SYSTEM

3. Invert the **SST** used in Step 1 and place it on the power brake unit.
4. Measure the clearance between the end of the **SST** and the push rod of the power brake unit.
  - If it is not **0.1—0.4 mm {0.004—0.016 in}**, loosen the push rod locknut and turn the push rod to adjust it using the **SSTs**.

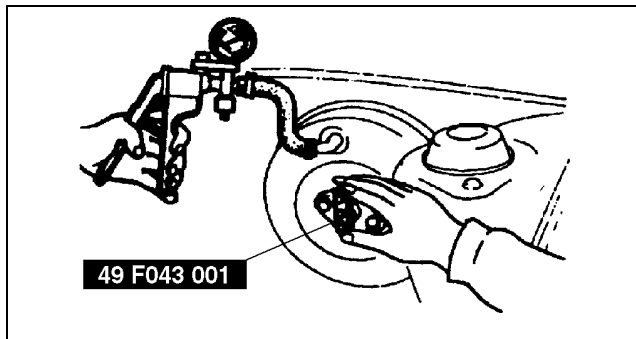

X3U411WAB

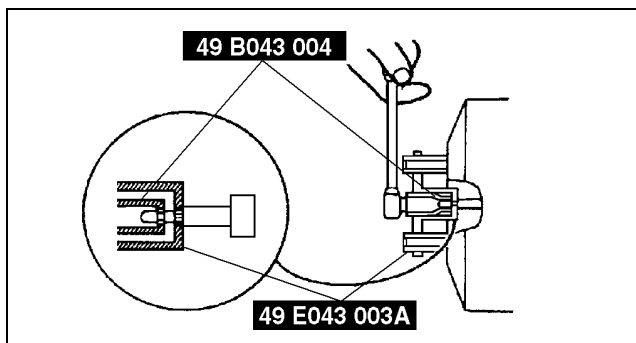

X3U411WAC

A3U041143540W01

04-11

### FLUID LEVEL SENSOR INSPECTION

1. Disconnect the sensor connector.
2. Connect an ohmmeter to the connector.
3. Starting with the fluid level above MIN, verify that there is no continuity.
4. Remove the brake fluid and verify that there is continuity when the level is below MIN.
  - If not as specified, replace the sensor.

○—○ : Continuity

Fluid level	Terminal	
	A	B
Below MIN	○—○	○—○
Above MIN		

X3U411WAD

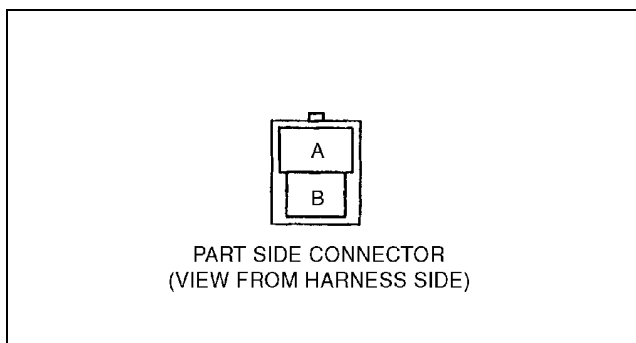

Y3U411WA1

# CONVENTIONAL BRAKE SYSTEM

## MASTER CYLINDER DISASSEMBLY/ASSEMBLY

A3U041143400W02

### Caution

- If the master cylinder body is damaged, replace the unit as an assembly. When securing the master cylinder in a vise, tighten only the flange of the master cylinder.

1. Disassemble in the order indicated in the table.
2. Assemble in the reverse order of disassembly.

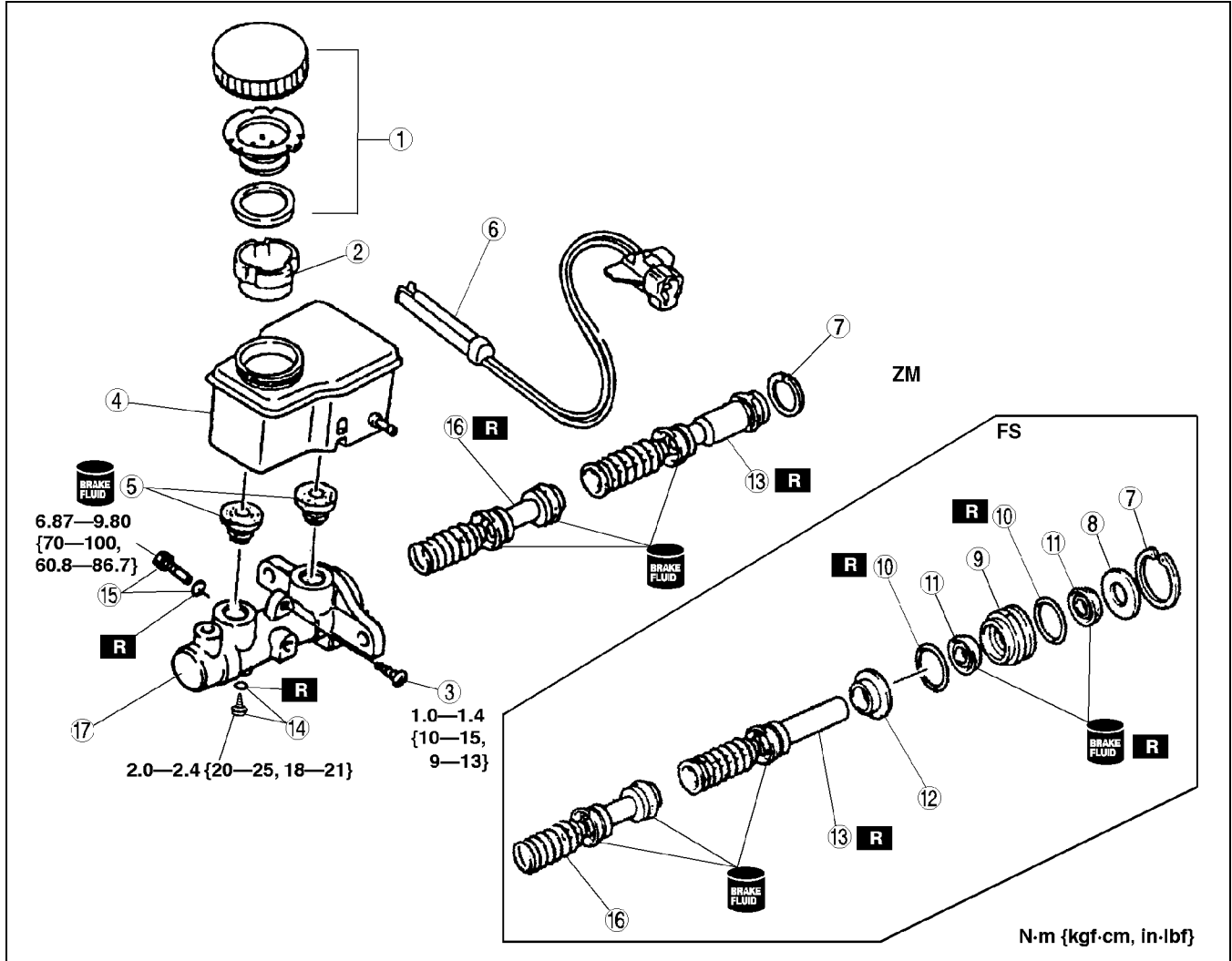

Z3U0411W011

1	Cap set
2	Float
3	Screw
4	Reservoir
5	Joint bushing
6	Fluid level sensor
7	Snap ring
8	Spacer
9	Piston guide
10	O-ring

11	Cup
12	Primary piston stopper
13	Primary piston
14	Stop screw and O-ring (without ABS) (See 04-11-11 Stop Screw and O-ring (without ABS) Assembly Note)
15	Stop pin and O-ring (with ABS) (See 04-11-11 Stop Pin and O-ring (with ABS) Assembly Note)
16	Secondary piston
17	Master cylinder body

## CONVENTIONAL BRAKE SYSTEM

### Stop Screw and O-ring (without ABS) Assembly Note

1. Install the secondary piston and primary piston.
2. Install the new O-ring onto the stop screw.
3. Push the primary piston assembly in full.
4. Install and tighten the stop screw.

#### Tightening torque

2.0—2.4 N·m {20—25 kgf·cm, 18—21 in·lbf}

5. Push and release the secondary piston component to verify that it is held properly by the stop screw.

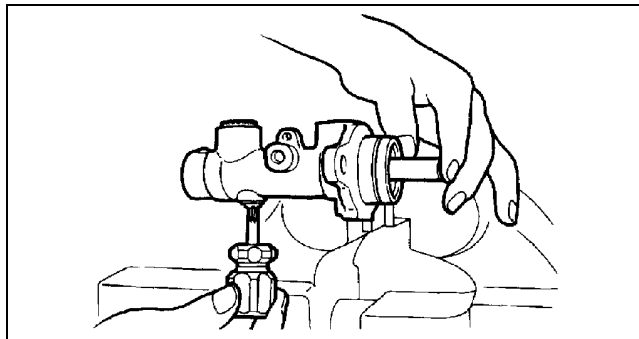

X3U411WAG

04-11

### Stop Pin and O-ring (with ABS) Assembly Note

1. Install the secondary piston with the piston hole facing the stop pin and primary piston.
2. Install the new O-ring onto the stop pin.
3. Push the primary piston assembly in full.
4. Install and tighten the stop pin.

#### Tightening torque

6.87—9.80 N·m {70—100 kgf·cm, 60.8—86.7 in·lbf}

5. Push and release the secondary piston component to verify that it is held properly by the stop pin.

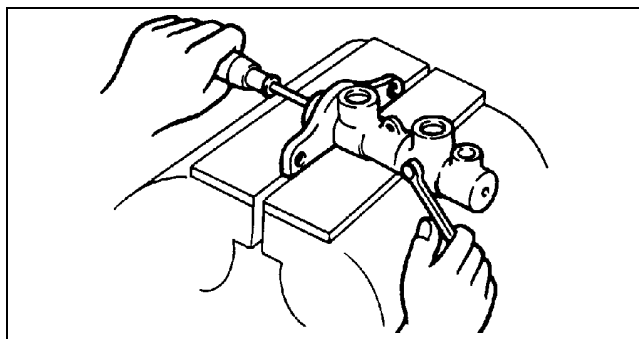

X3U411WAH

## POWER BRAKE UNIT INSPECTION

### Power Brake Unit Function Check

#### Simple method

#### Note

- Replace power brake unit component if necessary.

#### Step 1

1. With engine stopped, depress the pedal a few times.
2. With pedal depressed, start the engine.
  - If the pedal moves down slightly, immediately after engine starts, the unit is operating.
  - If not as specified, inspect for damage on the check valve or vacuum hose, and examine the installation. Repair if necessary, and inspect it again.

#### Step 2

1. Start the engine.
2. Stop the engine after it has run for **1 or 2 minutes**.
3. Depress the pedal with usual force.
  - If the first pedal stroke is long and becomes shorter with subsequent strokes, the unit is operating.
  - If not as specified, inspect for damage on the check valve or vacuum hose, and examine the installation. Repair if necessary, and inspect it again.

A3U041143800W01

# CONVENTIONAL BRAKE SYSTEM

### Step 3

1. Start the engine.
2. Depress the pedal with usual force.
3. Stop the engine with the pedal held depressed.
4. Hold the pedal down for **about 30 seconds**.
  - If the pedal height does not change, the unit is operating.
  - If not as specified, inspect for damage on the check valve or vacuum hose, and examine the installation. Repair if necessary, and inspect it again.

### Inspection using the testers

1. Connect the **SSTs**, vacuum gauge, and pedal depression force gauge as shown in the figure.

**Note**

- Use commercially available gauges and pedal depression force gauge.
- Bleed the air from the **SST** at gauge A.

2. After bleeding the air from the **SST**, conduct the test as described in the following steps.

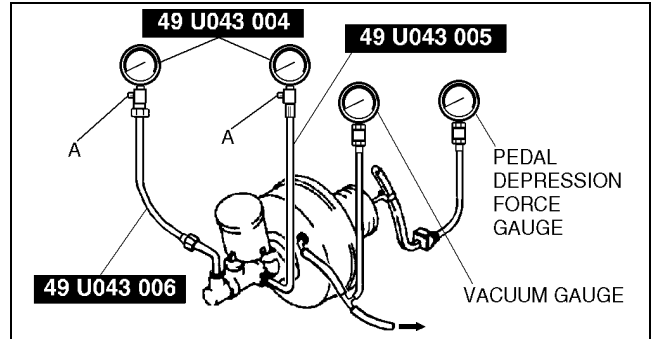

A3U0411W002

### Checking for vacuum loss (unloaded condition)

1. Start the engine.
2. Stop the engine when the vacuum gauge reading reaches **66.7 kPa {500 mmHg, 19.7 inHg}**.
3. Observe the vacuum gauge for **15 seconds**.
  - If the gauge shows **63.4—66.6 kPa {475—500 mmHg, 18.8—19.6 inHg}**, the unit is operating.
  - If a problem is found, inspect for damage on the check valve or vacuum hose, and examine the installation. Repair if necessary, and inspect it again.

### (loaded condition)

1. Start the engine.
2. Depress the brake pedal with a force of **200 N {20 kgf, 44 lbf}**.
3. With the brake pedal depressed, stop the engine when the vacuum gauge reading reaches **66.7 kPa {500 mmHg, 19.7 inHg}**.
4. Observe the vacuum gauge for **15 seconds**.
  - If the gauge shows **63.4—66.6 kPa {475—500 mmHg, 18.8—19.6 inHg}**, the unit is operating.
  - If a problem is found, inspect for damage on the check valve or vacuum hose, and examine the installation. Repair if necessary, and inspect it again.

### Checking for hydraulic pressure

1. When the engine is stopped (vacuum **0 kPa {0 mmHg, 0 inHg}**) and the fluid pressure is within the specification, the unit is operating.

Engine type	Pedal force	Fluid pressure
ZM	200 N {20 kgf, 44 lbf}	650 kPa {7 kgf/cm <sup>2</sup> , 94 psi} min.
FS		600 kPa {6 kgf/cm <sup>2</sup> , 87 psi} min.

2. Start the engine. Depress the brake pedal when the vacuum reaches **66.7 kPa {500 mmHg, 19.7 inHg}**.
  - If the fluid pressure is within the specification, the unit is operating.
  - If the fluid pressure is not as specified, inspect for damage on the check valve or vacuum hose, and fluid leakage of the hydraulic line. Repair as necessary, and inspect again.

Engine type	Pedal force	Fluid pressure
ZM	200 N {20 kgf, 44 lbf}	6,500 kPa {66 kgf/cm <sup>2</sup> , 943 psi} min.
FS		7,200 kPa {73 kgf/cm <sup>2</sup> , 1,044 psi} min.

# CONVENTIONAL BRAKE SYSTEM

## POWER BRAKE UNIT REMOVAL/INSTALLATION

1. Remove the battery and battery cover.
2. Remove the master cylinder. (See 04-11-6 MASTER CYLINDER REMOVAL/INSTALLATION.)
3. Remove in the order indicated in the table.

1	Vacuum hose
2	Snap pin
3	Clevis pin
4	Nut
5	Power brake unit
6	Gasket
7	Fork
8	Nut

4. Install in the reverse order of removal.

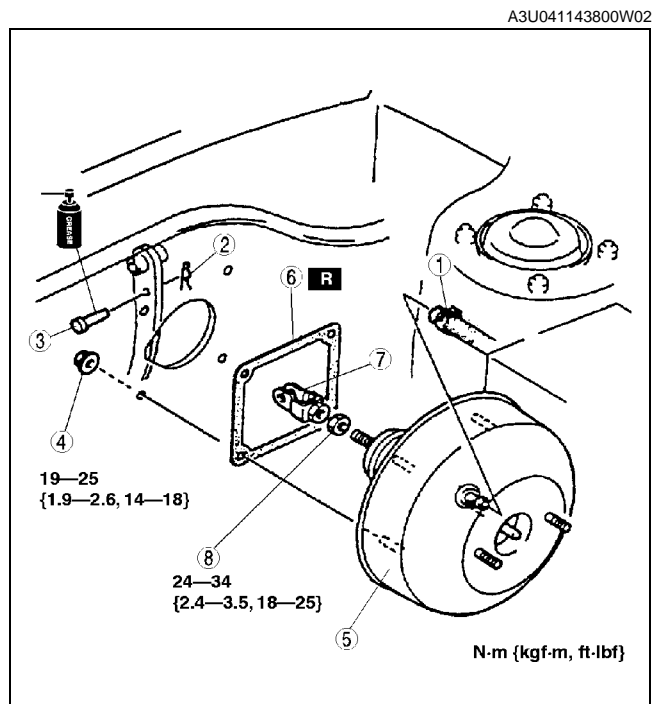

04-11

## DUAL PROPORTIONING VALVE (WITHOUT ABS) INSPECTION

1. Connect the **SSTs** to the brake pipes as shown in the figure.
2. Bleed the air from the brake system.

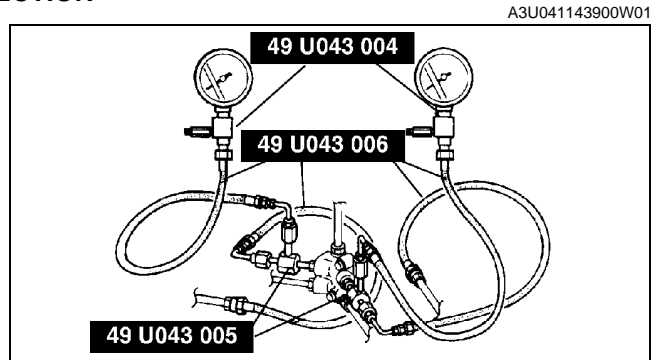

3. Measure the fluid pressure of the master cylinder and the rear brake.
  - If not within the specification, replace the dual proportioning valve.

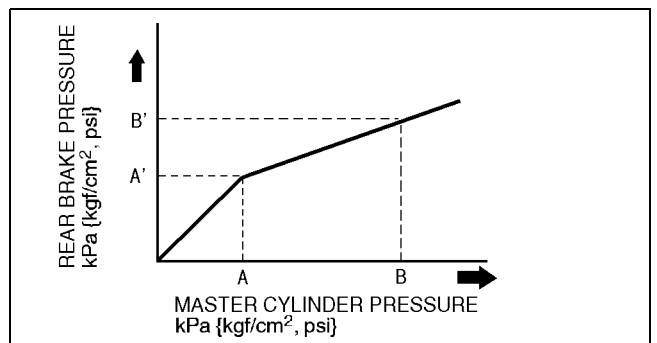

### Fluid pressure

Engine type	A	A'	B	B'
ZM	2,900 {30, 430}	2,900 {30, 430}±200 {2, 30}	5,900 {60, 850}	3,800 {39, 550}±300 {3, 40}
FS	3,400 {35, 500}	3,400 {35, 500}±300 {3, 40}	5,900 {60, 850}	4,200 {42.5, 600}±400 {4, 60}

kPa {kgf/cm<sup>2</sup>, psi}



# CONVENTIONAL BRAKE SYSTEM

## DUAL PROPORTIONING VALVE (WITHOUT ABS) AND BRAKE PIPE JOINT (WITH ABS) REPLACEMENT

A3U041143900W02

1. Remove in the order indicated in the table.
2. Install in the reverse order of removal.

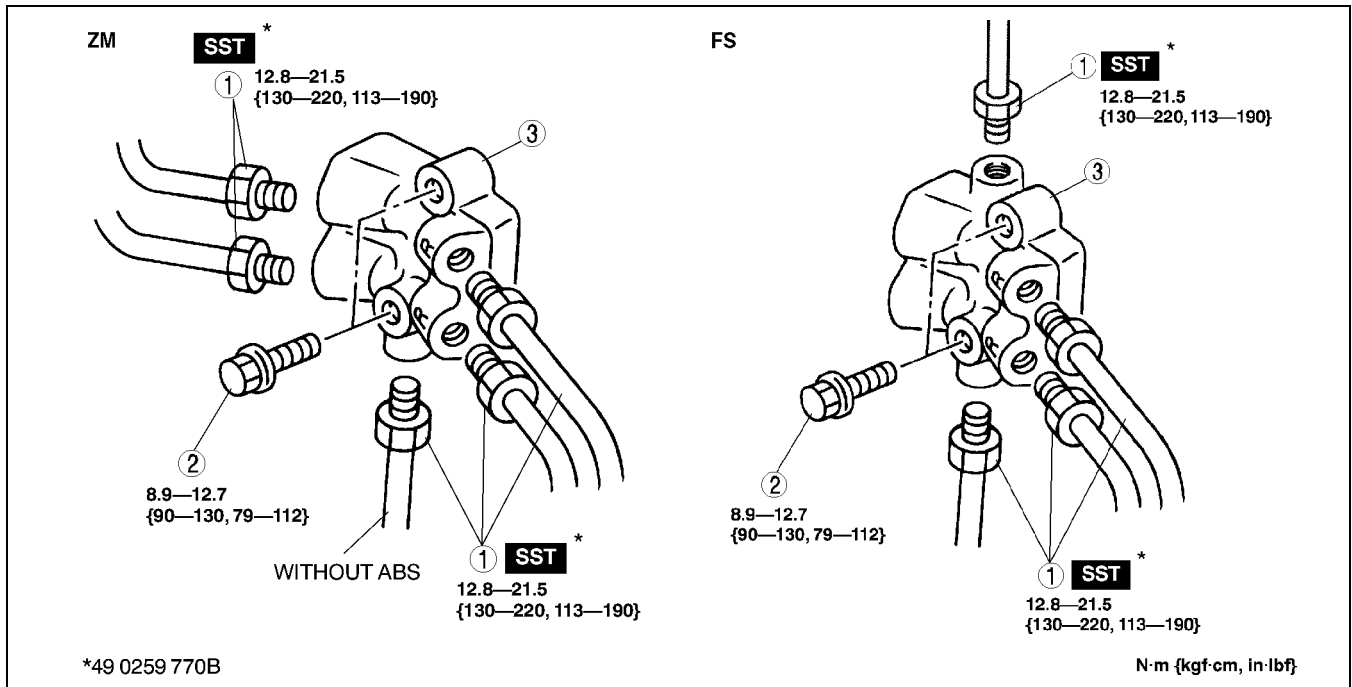

Z3U0411W001

1	Brake pipe
2	Bolt

3	Dual proportioning valve (without ABS) or brake pipe joint (with ABS) (See 04-11-14 Dual Proportioning Valve (Without ABS) or Brake Pipe Joint (With ABS) Installation Note)
---	---

### Dual Proportioning Valve (Without ABS) or Brake Pipe Joint (With ABS) Installation Note

1. Install the dual proportioning valve so that the R mark faces the left side of the vehicle.

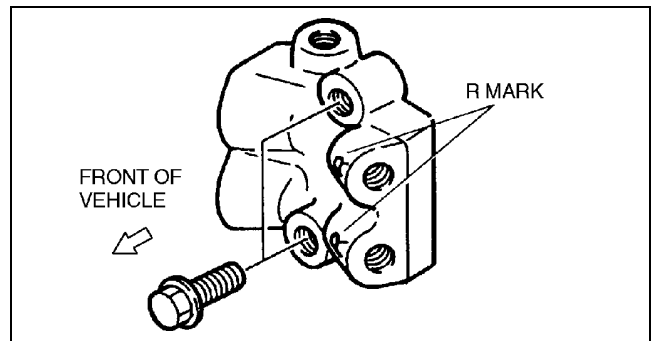

X3U411WAP

## FRONT BRAKE (DISC) INSPECTION

### Brake Judder Repair Hint

#### Description

1. Brake judder concern has the following 3 characteristics:

#### Steering wheel vibration

1. Steering wheel vibrates in the direction of its rotation. This characteristic is most noticeable when applying brakes at a vehicle speed of **100—140 km/h {62.1—86.8 mph}**.

#### Floor vibration

1. When applying brakes, the vehicle body shakes back and forth. The seriousness of shake is not influenced by vehicle speed.

A3U041133980W01

# CONVENTIONAL BRAKE SYSTEM

## Brake pedal vibration

1. When applying brakes, a pulsating force tries to push the brake pad back occurs. The pulsation is transmitted to the brake pedal.
2. The following are the main possible causes of brake judder:

### Due to an excessive runout (side-to-side wobble) of disc plate, the thickness of disc plate is uneven.

1. If the runout is **more than 0.05 mm {0.002 in} 10 mm {0.39 in}** from the disc plate edge, an uneven wear occurs on the disc plate because the pad contacts the plate unevenly.
2. If the runout is **less than 0.05 mm {0.002 in}**, uneven wear does not occur.

### The disc plate is deformed by heat.

1. Repeated panic braking may raise the temperature in some portions of disc plate by **approximately 1,000 °C {1,832 °F}**. This results in deformed disc plate.

### Due to corrosion, the thickness and friction coefficient of disc plate change.

1. If a vehicle is parked under damp conditions for a long time, corrosion occurs on the friction surface of disc plate.
2. The thickness of corrosion is uneven and sometimes appears like a wave pattern, which changes the friction coefficient and causes a reaction force.

04-11

## Inspection and repair procedure

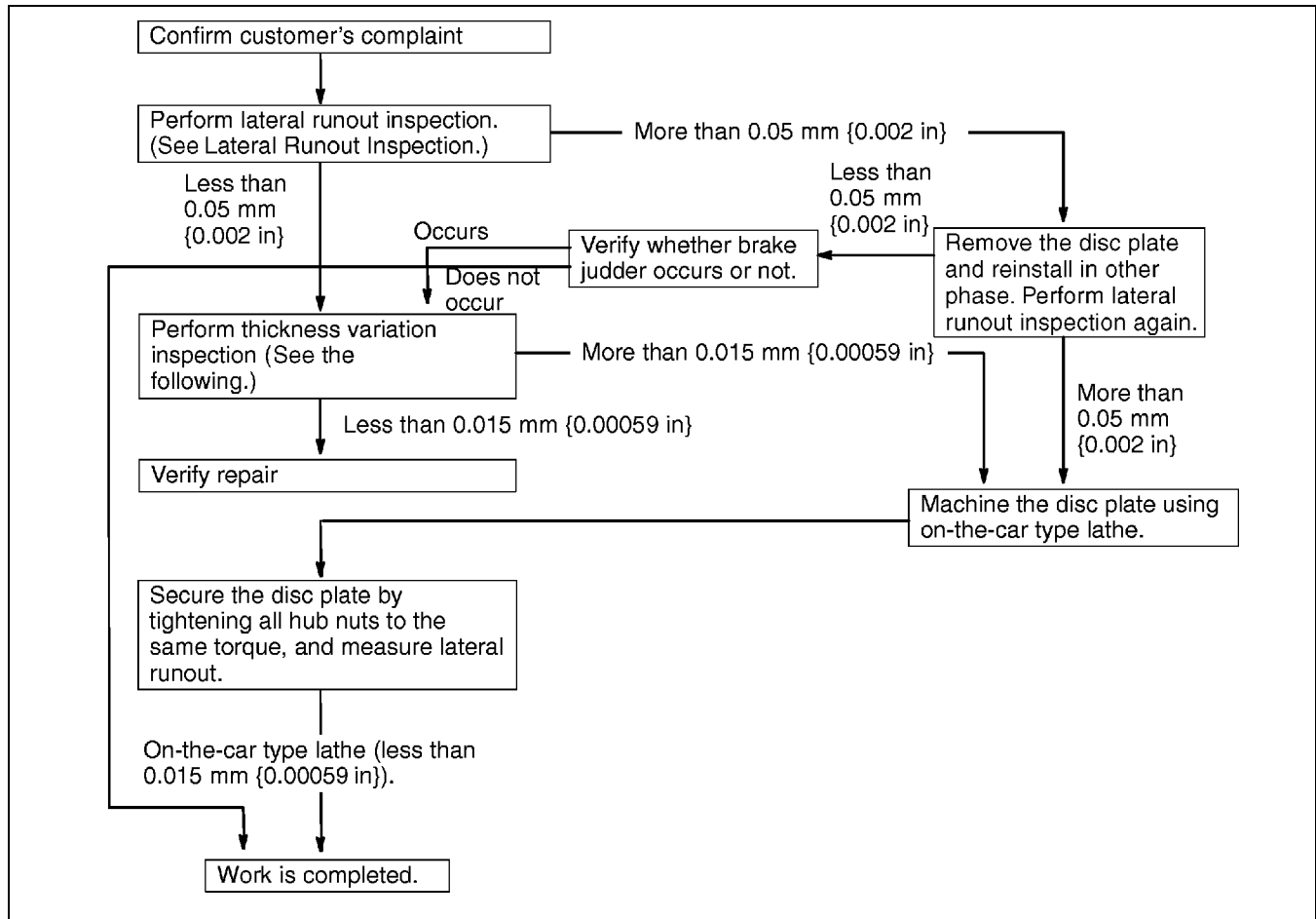

Y3U411WA4

# CONVENTIONAL BRAKE SYSTEM

## Lateral runout inspection

1. To secure the disc plate and the hub, tighten the hub nuts upside down or insert a washer (thickness **10 mm {0.39 in}**, inner diameter **more than 12 mm {0.47 in}**) between the hub bolt and the hub nut.

### Note

- The component parts of the **SST** (49 B017 001 or 49 G019 003) can be used as a suitable washer.

2. After tightening all the hub nuts to the same torque, put the dial gauge on the friction surface of disc plate **10 mm {0.39 in}** from the disc plate edge.
3. Rotate the disc plate one time and measure the runout.

### Runout limit

**0.05 mm {0.002 in}**

## Thickness variation inspection

1. Clean the disc plate-to-pad friction surface using a brake cleaner.
2. Measure the points indicated in the illustration using a caliper (micrometer).
3. Subtract the minimum value from the maximum, and if the result is not within specification, machine the disc plate using a lathe.

### Thickness variation limit

**0.015 mm {0.00059 in}**

### Warning

- **Do not exceed minimum disc plate thickness.**

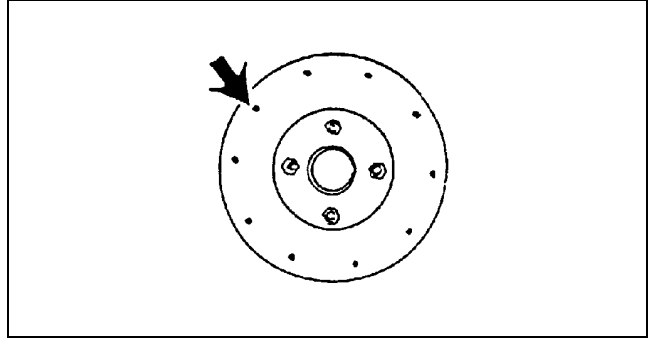

X3U411WAR

## Disc Plate Thickness Inspection

### Caution

- **Excessive runout may result if the disc plate is removed from the vehicle then machined. Machine the disc plate while installed on the vehicle.**

1. Measure the thickness of the disc plate.
  - If the thickness is not within the specification, replace the disc plate.

### Minimum

**ZM: 20 mm {0.78 in}**

**FS: 22 mm {0.87 in}**

### Minimum thickness after machining using a brake lathe on-vehicle

**ZM: 20.8 mm {0.82 in}**

**FS: 22.8 mm {0.90 in}**

## Disc Pad Thickness Inspection

1. Jack up the front of the vehicle and support it with safety stands.
2. Remove the wheel and tires.
3. Verify the remaining thickness of the pads.

### Minimum thickness

**ZM: 1.5 mm {0.059 in} min.**

**FS: 2.0 mm {0.079 in} min.**

4. Replace the pads as a set: right and left wheels, if either one is at or less than the minimum thickness.

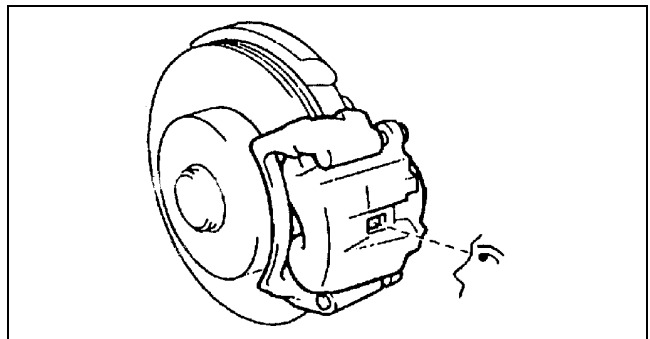

X3U411WAS

# CONVENTIONAL BRAKE SYSTEM

## FRONT BRAKE (DISC) REMOVAL/INSTALLATION

A3U041133980W02

1. Remove in the order indicated in the table.
2. Install in the reverse order of removal.
3. After installation, depress the pedal a few times, rotate the wheel by hand, and verify that the brake does not drag.

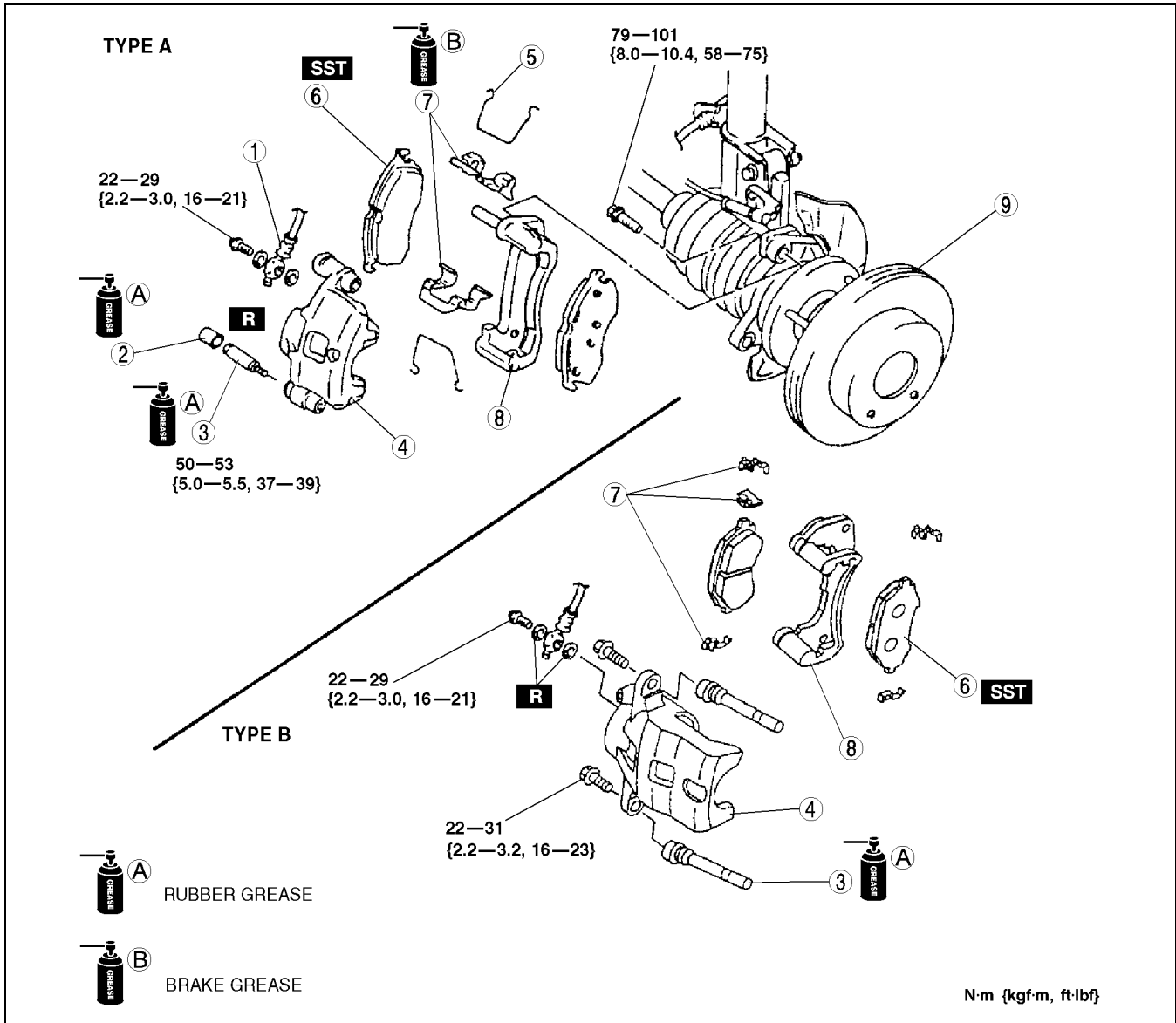

04-11

Z3U0411W003

1	Flexible hose
2	Cap (type A only)
3	Guide pin
4	Caliper
5	M-spring (type A only)

6	Disc pad (See 04-11-18 Disc Pad Installation Note)
7	Guide plate
8	Mounting support
9	Disc plate (See 04-11-18 Disc Plate Removal Note) (See 04-11-18 Disc Plate Installation Note)

## CONVENTIONAL BRAKE SYSTEM

### Disc Plate Removal Note

1. Mark the wheel hub bolt and disc plate before removal for reference during installation.

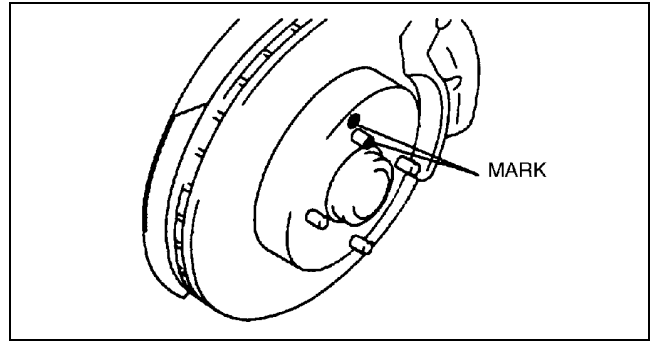

X3U411WAU

### Disc Plate Installation Note

1. Remove any rust or grime on the contact face of the disc plate and wheel hub.
2. Install the disc plate and align the marks made before removal.

### Disc Pad Installation Note

1. Push the piston fully inward using the **SST**.
2. Install the disc pad.

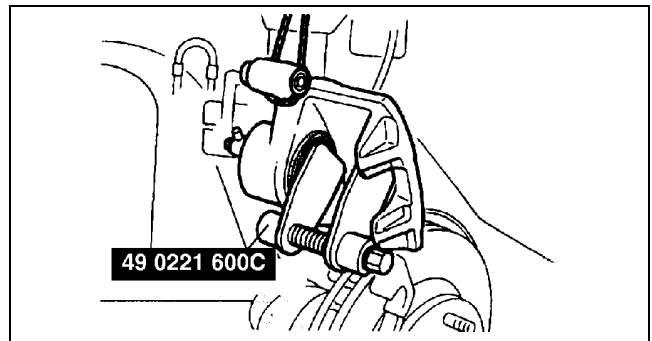

X3U411WAV

# CONVENTIONAL BRAKE SYSTEM

## DISC PAD (FRONT) REPLACEMENT

A3U041133630W01

1. Remove in the order indicated in the table.
2. Install in the reverse order of removal.

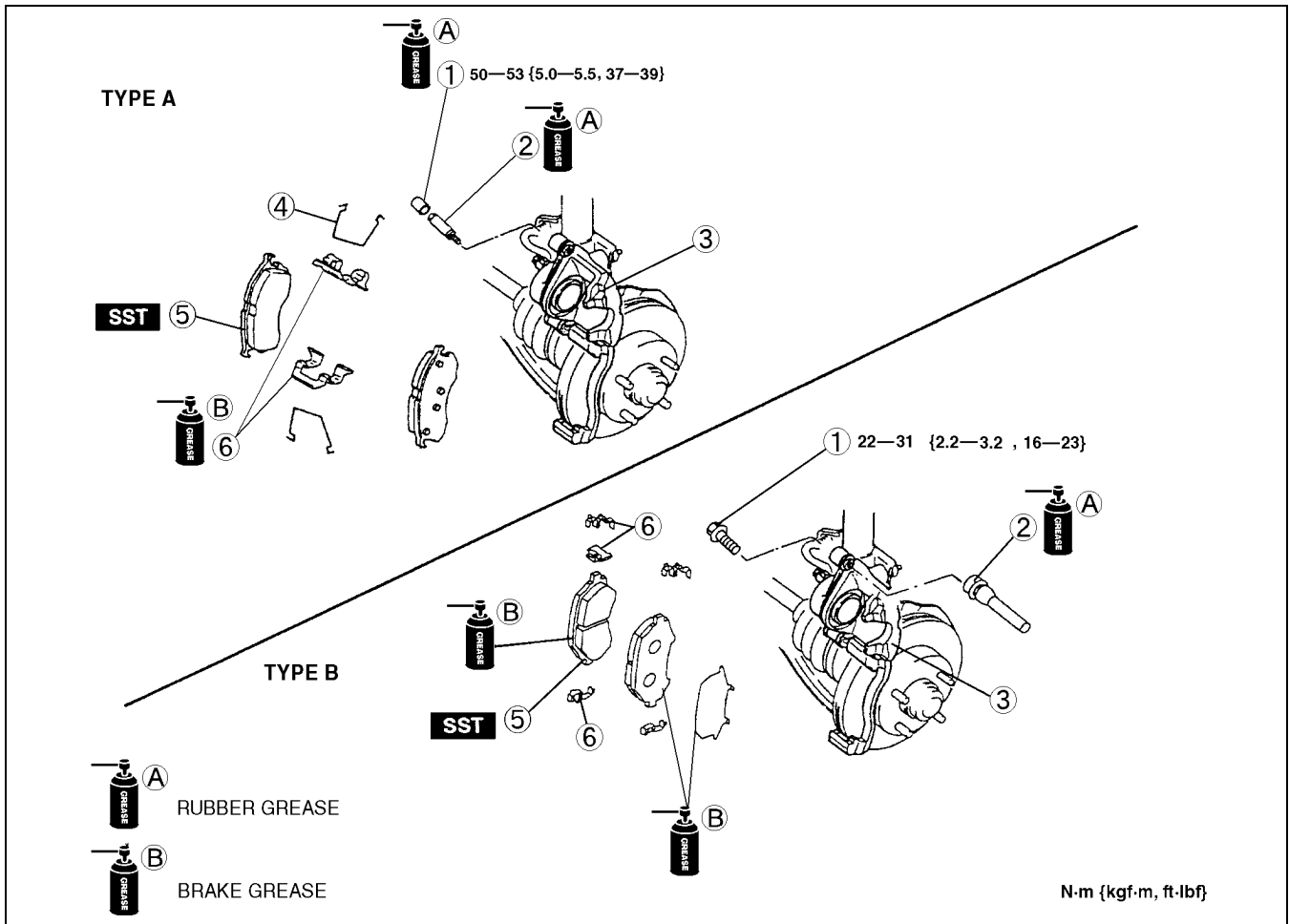

04-11

Z3U0411W004

1	Cap (type A), bolt (type B)
2	Guide pin
3	Caliper

4	M-spring (type A only)
5	Disc pad (See 04-11-18 Disc Pad Installation Note)
6	Guide plate

# CONVENTIONAL BRAKE SYSTEM

## CALIPER (FRONT) DISASSEMBLY/ASSEMBLY

A3U041133990W01

1. Disassemble in the order indicated in the table.

1	Dust seal
2	Piston (See 04-11-20 Piston Disassembly Note)
3	Piston seal (See 04-11-20 Piston Seal Disassembly Note)
4	Bleeder cap
5	Bleeder screw (See 04-11-21 Bleeder Screw Assembly Note)
6	Caliper body
7	Boot

2. Assemble in the reverse order of removal.

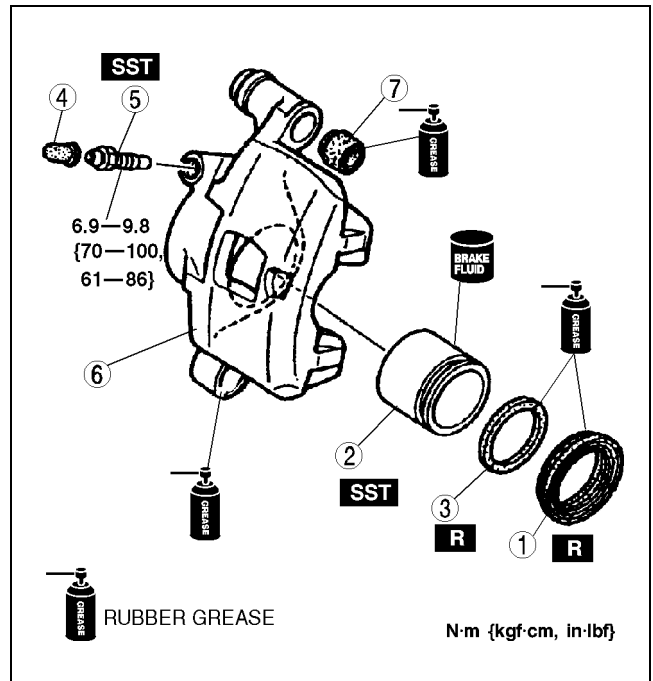

Z3U0411W005

### Piston Disassembly Note

#### Caution

- Blow the compressed air slowly to prevent the piston from suddenly popping out.

1. Place a piece of wood in the caliper, then blow compressed air through the hole to force the piston out of the caliper.

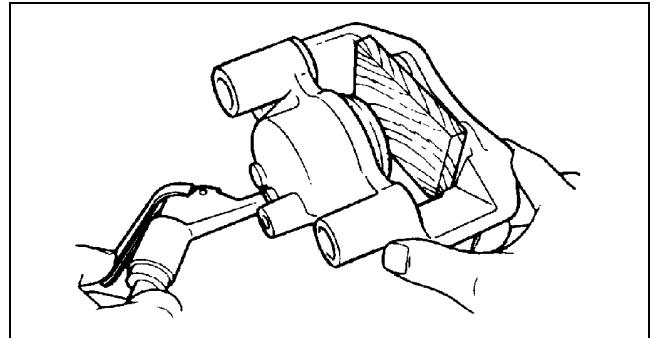

X3U411WAY

### Piston Seal Disassembly Note

1. Remove the piston seal from the brake caliper using the SST.

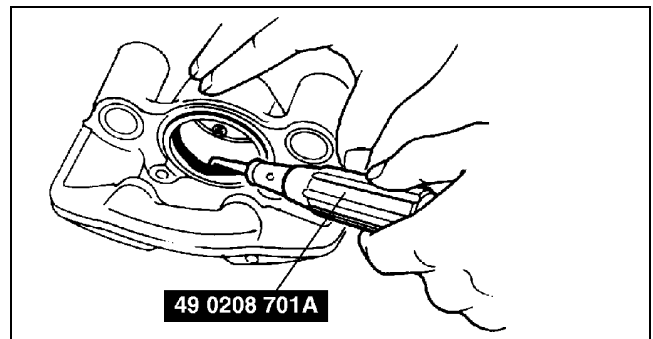

X3U411WAZ

# CONVENTIONAL BRAKE SYSTEM

## Bleeder Screw Assembly Note

1. Assemble the bleeder screw to the caliper using the **SST**.

### Tightening torque

6.9—9.8 N·m {70—100 kgf·cm, 61—86 in·lbf}

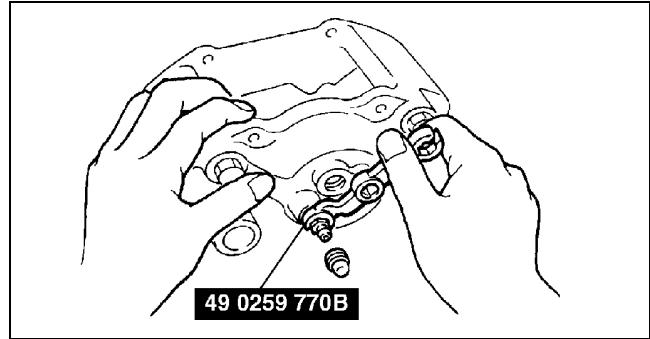

X3U411WB0

04-11

## REAR BRAKE (DISC) INSPECTION

### Brake Judder Repair Hint

(See 04-11-14 Brake Judder Repair Hint.)

A3U041126980W01

### Disc Pad Thickness Inspection

1. Jack up the rear of the vehicle and support it on safety stands.
2. Remove the wheel and tires.
3. Look through the caliper inspection hole and inspect the remaining thickness of the pads.
  - Replace the pads as a set (right and left wheels) if either is less than the minimum thickness.

### Minimum thickness

1.0 mm {0.039 in}

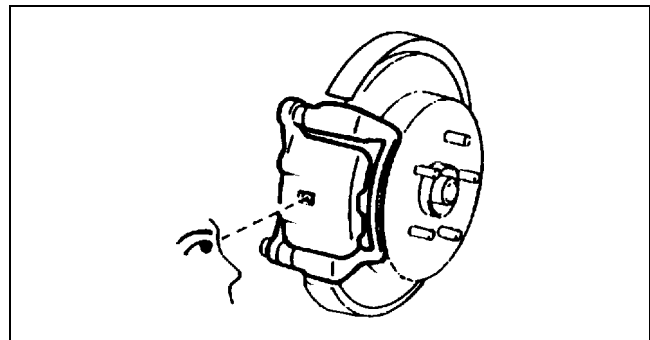

W6U411WB7

### Disc Plate Thickness Inspection

1. Measure the thickness of the disc plate.
  - If the thickness is not within the specification, replace the disc plate.

### Caution

- When it is necessary to machine the disc plate, and the disc plate is removed from the vehicle then machined, excessive runout may result. Machine the disc plate which is installed on the vehicle.

### Minimum

8 mm {0.31 in}

### Minimum thickness after machining by using a brake lathe on-vehicle

8.8 mm {0.35 in}



# CONVENTIONAL BRAKE SYSTEM

A3U041126980W02

## REAR BRAKE (DISC) REMOVAL/INSTALLATION

1. Remove in the order indicated in the table.
2. Install in the reverse order of removal.
3. After installation, depress the pedal several times, rotate the wheel by hand, and verify that the brake does not drag.

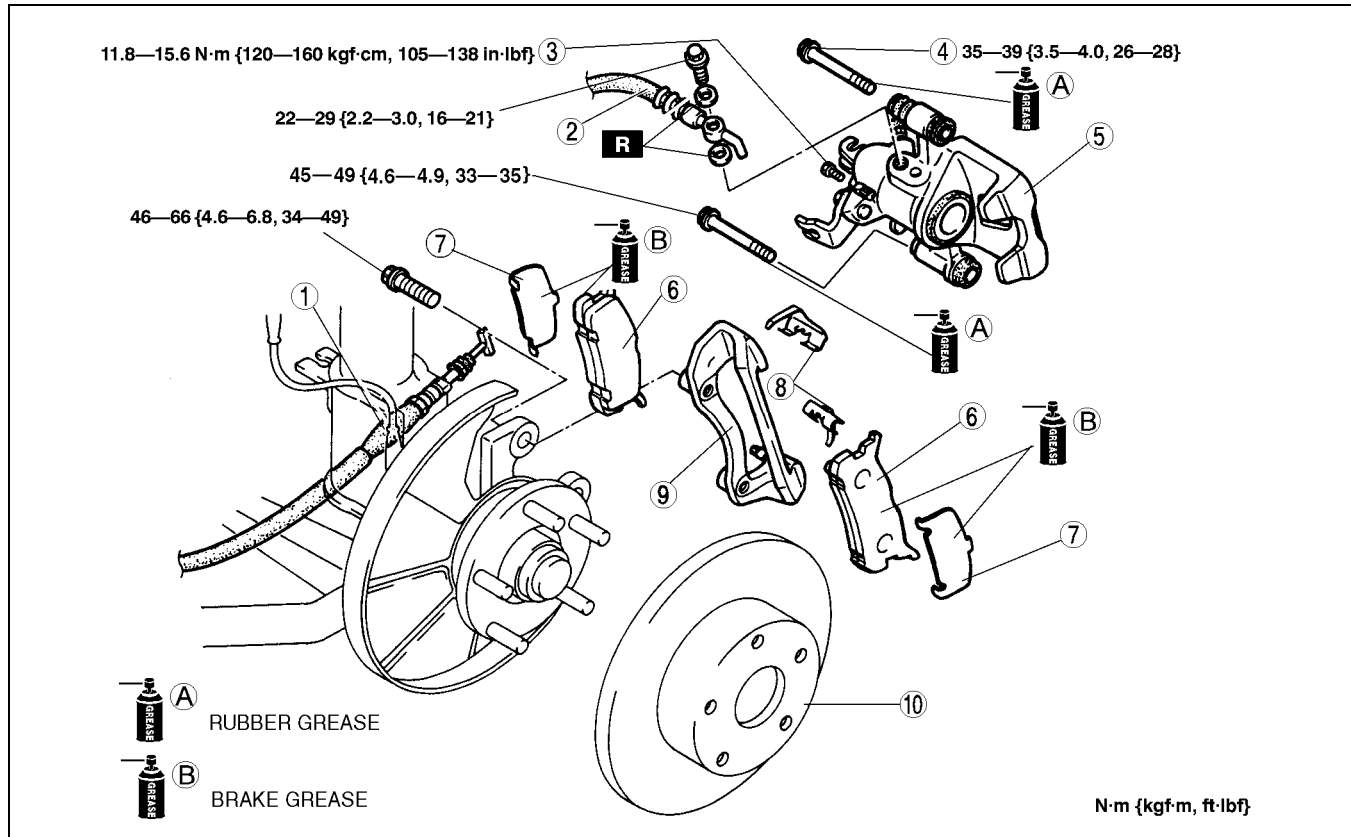

A3U0411W101

1	Parking brake cable, clip
2	Flexible hose
3	Screw plug
4	Lock bolt
5	Caliper
6	Disc pad (See 04-11-22 Disc Pad Installation Note)

7	Shim
8	Guide plate
9	Mounting support
10	Disc plate (See 04-11-18 Disc Plate Removal Note) (See 04-11-18 Disc Plate Installation Note)

### Disc Pad Installation Note

1. Turn the manual adjustment gear counterclockwise with an Allen wrench to pull the brake caliper piston inward. (Turn until it stops.)
2. Install the disc pads.
3. Turn the manual adjustment gear clockwise until the brake pads just touch the disc plate. Turn the manual adjustment gear back 1/3-turn.

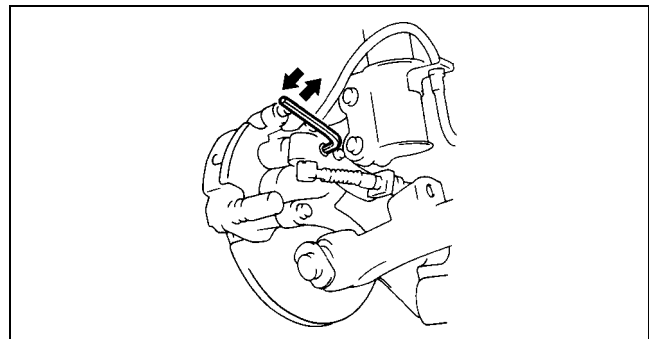

W6U411WB9

# CONVENTIONAL BRAKE SYSTEM

## DISC PAD (REAR) REPLACEMENT

A3U041126630W01

1. Remove in the order indicated in the table.
2. Install in the reverse order of removal.

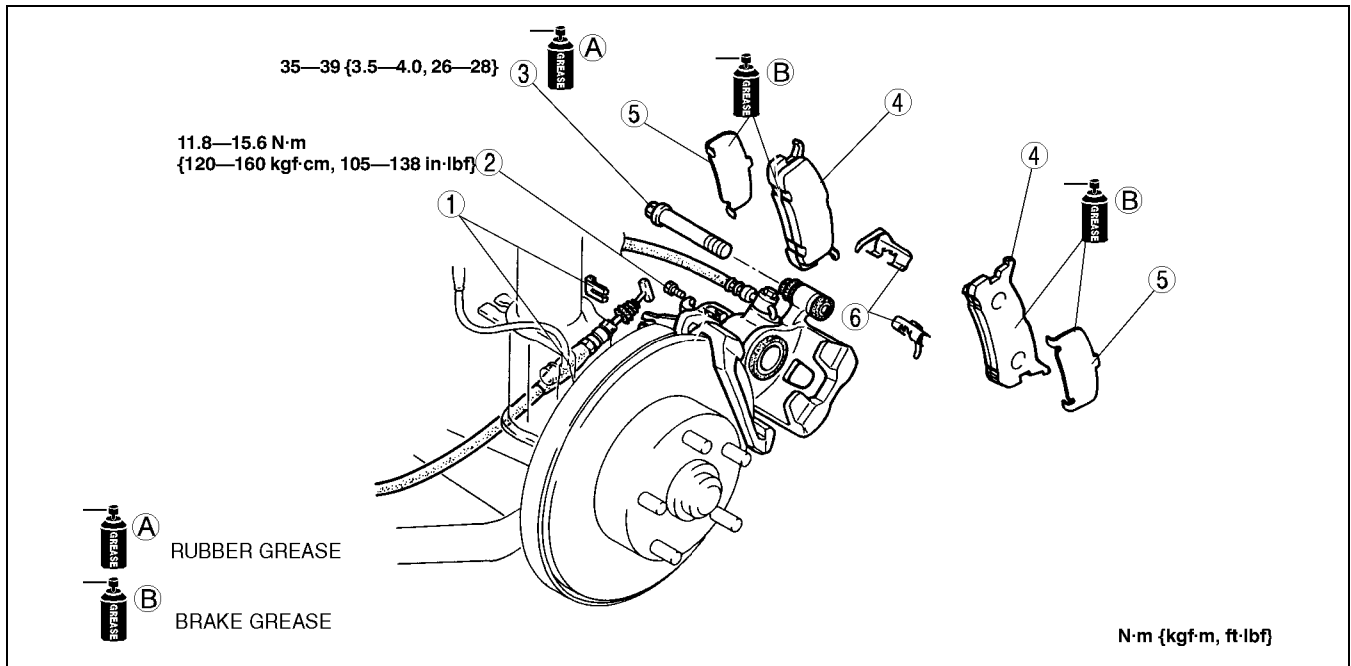

04-11

Z3U0411W009

1	Parking brake cable, clip
2	Screw plug
3	Lock bolt

4	Disc pad (See 04-11-22 Disc Pad Installation Note)
5	Shim
6	Guide plate

# CONVENTIONAL BRAKE SYSTEM

A3U041126990W01

## CALIPER (REAR) DISASSEMBLY/ASSEMBLY

1. Disassemble in the order indicated in the table.
2. Assemble in the reverse order of disassembly.

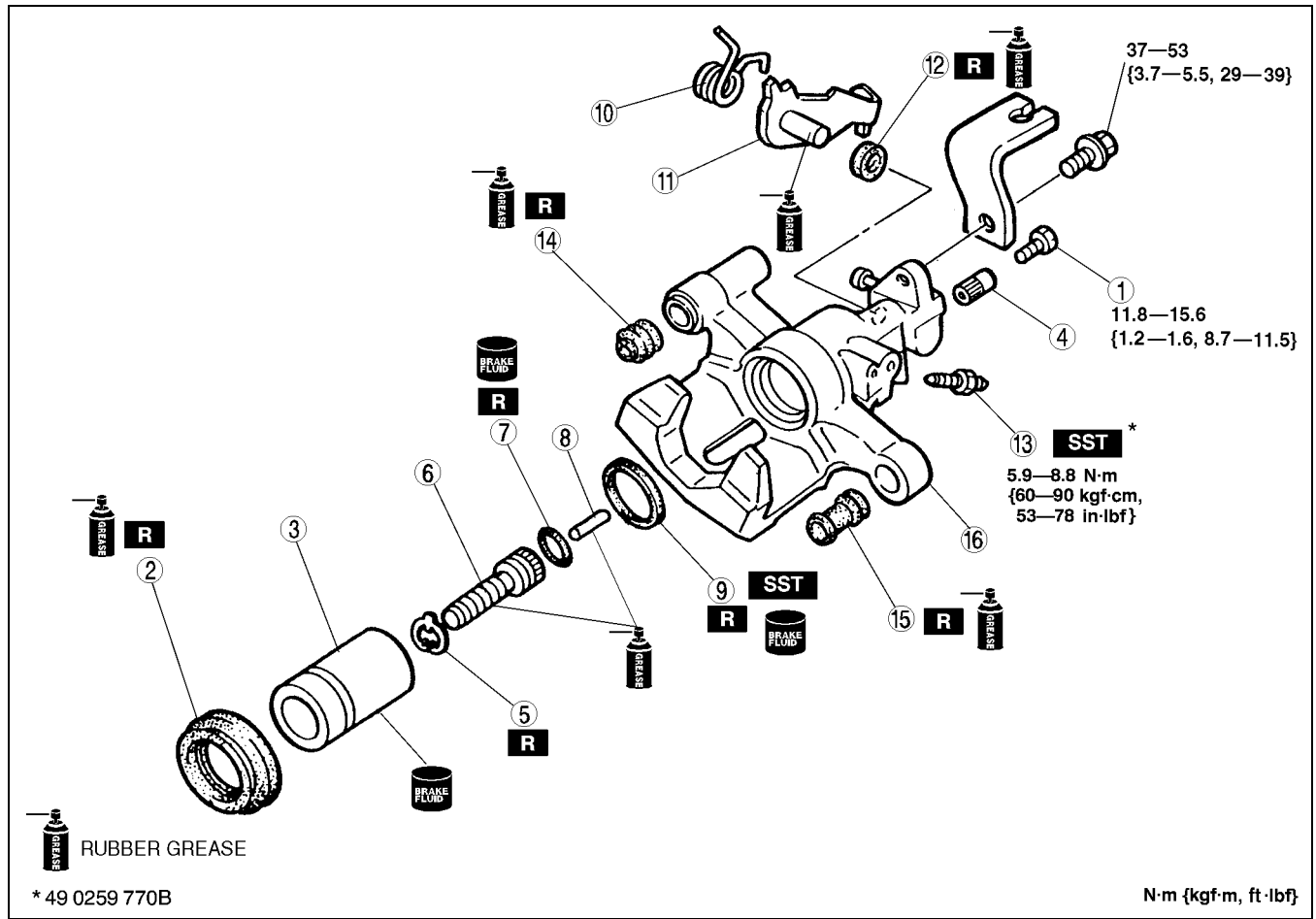

Z3U0411W010

1	Screw plug
2	Dust seal
3	Piston (See 04-11-24 Piston Disassembly Note) (See 04-11-25 Piston Assembly Note)
4	Manual adjustment gear
5	Snap ring
6	Adjusting bolt
7	O-ring
8	Connecting link

9	Piston seal (See 04-11-20 Piston Seal Disassembly Note)
10	Spring
11	Operating lever
12	Boot
13	Bleeder screw
14	Boot
15	Boot
16	Caliper body

### Piston Disassembly Note

- Turn the adjustment gear clockwise with an Allen wrench to remove the piston from the adjustment gear. (Turn the adjustment gear until it becomes easy to turn.)

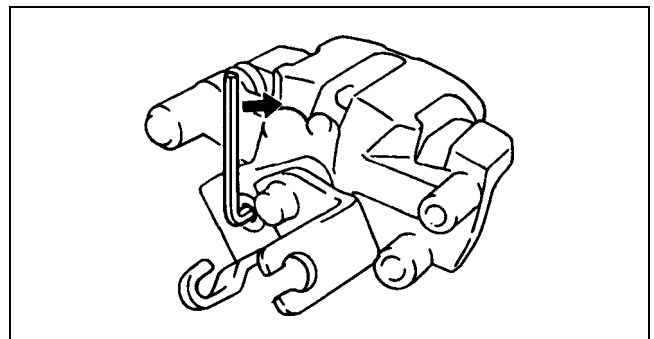

W6U411WBC

# CONVENTIONAL BRAKE SYSTEM

## Piston Assembly Note

- Insert the piston into the caliper and turn the adjustment gear counterclockwise with an Allen wrench to pull the piston inward. (Turn until it stops.)

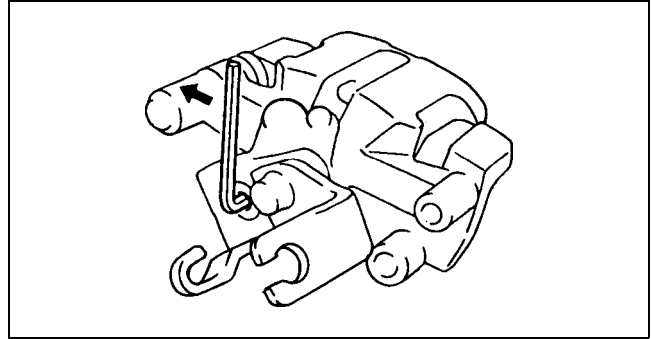

W6U411WBD

A3U041126250W01

04-11

## REAR BRAKE (DRUM) INSPECTION

### Brake Lining Thickness Inspection

1. Remove the brake drum.
2. Inspect the remaining thickness of the lining.

#### Thickness

**1.0 mm {0.039 in} min.**

3. Replace both left and right brake shoes if either is at or less than the minimum thickness.

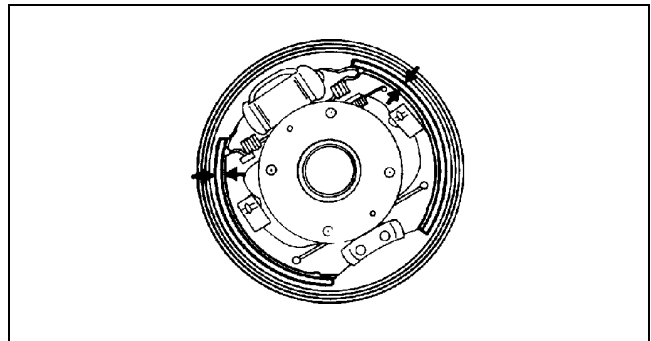

X3U411WB1

### Brake Drum Inspection

1. Measure the inner diameter of the drum.

#### Maximum diameter

**201.5 mm {7.933 in}**

2. Inspect for scratches and uneven or abnormal wear inside the drum.
3. Repair or replace the drum if necessary.

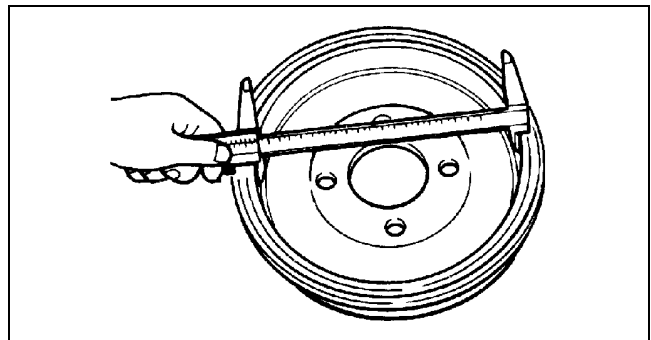

X3U411WB2

4. When repairing or replacing the drum, inspect the contact with the shoes.

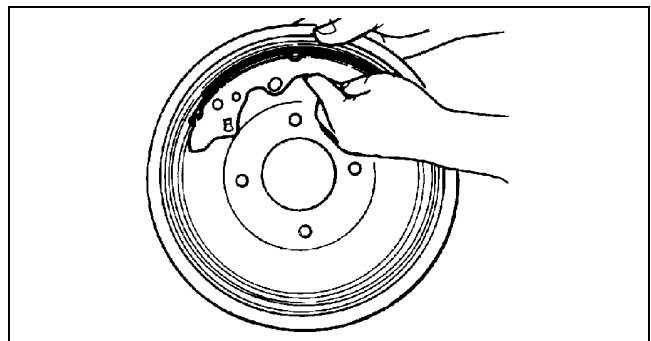

X3U411WB3

# CONVENTIONAL BRAKE SYSTEM

A3U041126250W02

## REAR BRAKE (DRUM) REMOVAL/INSTALLATION

1. Remove in the order indicated in the table.
2. Install in the reverse order of removal.
3. Perform the following.
  - (1) Depress the brake pedal a few times. Then verify that the brakes do not drag.
  - (2) Inspect the pedal-to-floor clearance.
  - (3) Inspect the parking brake lever stroke.

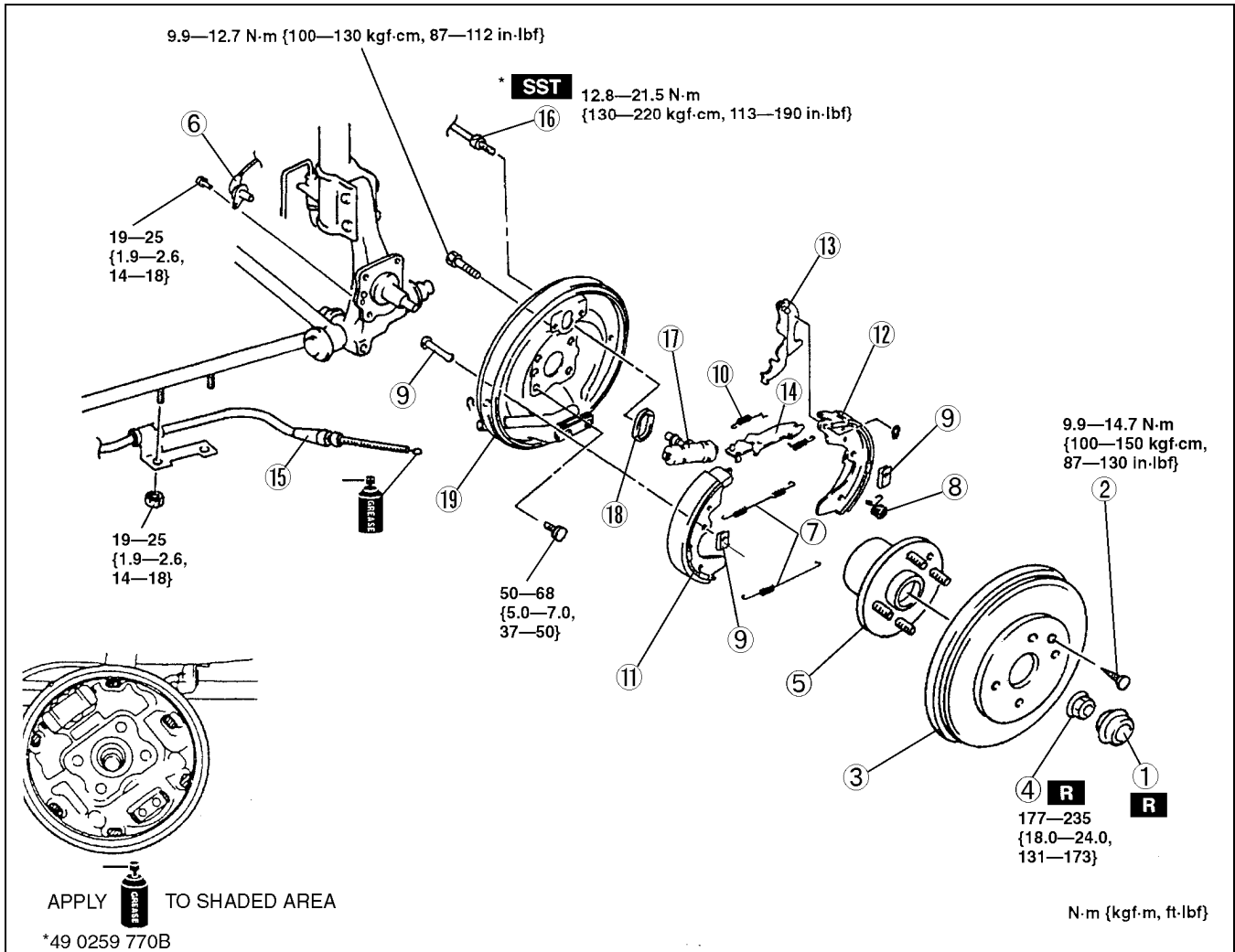

Y3U411WA6

1	Hub cap
2	Screw
3	Brake drum (See 04-11-27 Brake Drum Removal Note) (See 04-11-27 Brake Drum Installation Note)
4	Locknut (See 03-11-4 Locknut Removal Note) (See 03-11-7 Locknut Installation Note)
5	Wheel hub
6	ABS wheel-speed sensor (if equipped)
7	Return spring
8	Lever spring

9	Hold pin and hold spring
10	Anti-rattle spring
11	Leading shoe
12	Trailing shoe
13	Operating lever
14	Adjuster
15	Parking brake cable
16	Brake pipe
17	Wheel cylinder
18	O-ring
19	Backing plate

# CONVENTIONAL BRAKE SYSTEM

## Brake Drum Removal Note

1. Mark the wheel hub bolt and brake drum before removal for reference during installation.

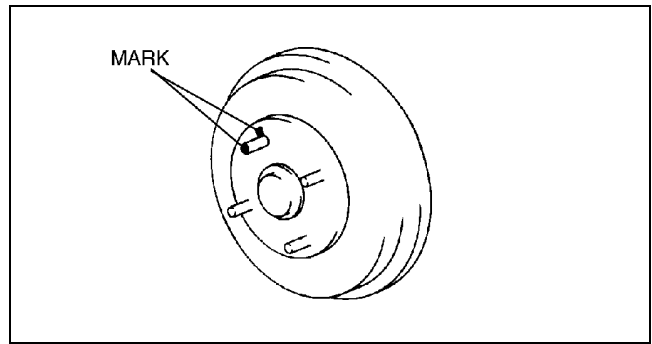

X3U411WB5

## Brake Drum Installation Note

1. Remove any rust or grime on the contact face of the drum brake.
2. Install the brake drum and align the marks made before removal.

04-11

## WHEEL CYLINDER DISASSEMBLY/ASSEMBLY

A3U041126610W01

### Caution

- Replace the wheel cylinder component if a problem is found.

1. Disassemble in the order indicated in the table.
2. Assemble in the reverse order of disassembly.

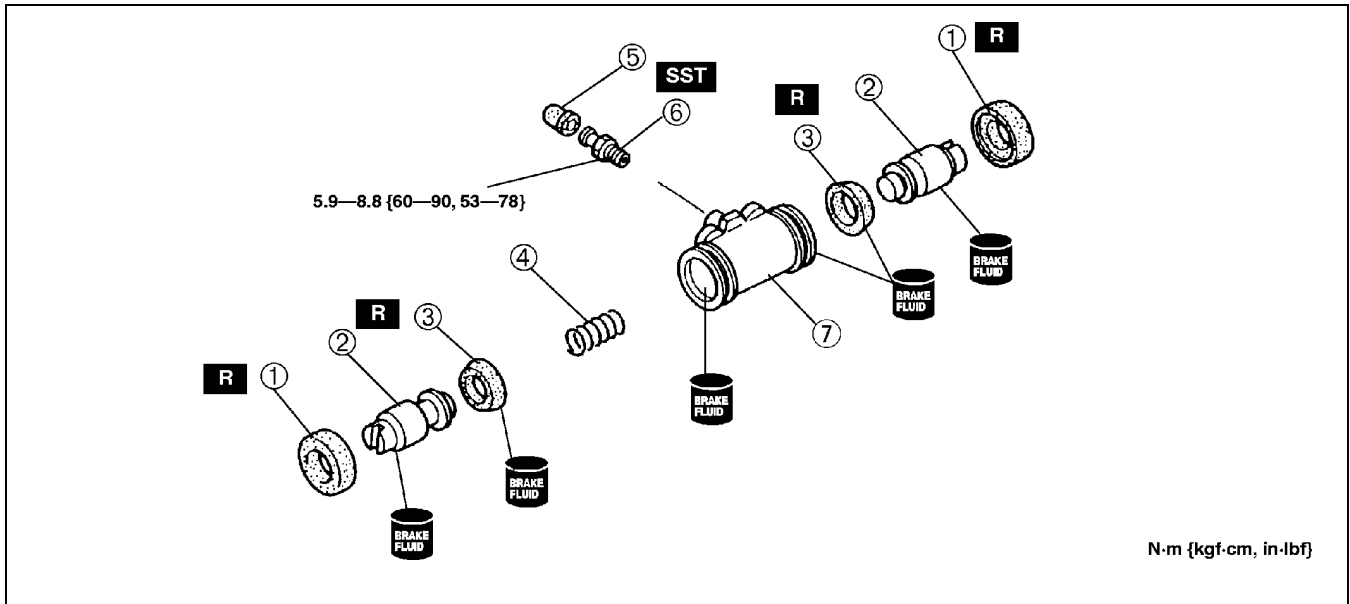

N·m {kgf·cm, in·lbf}

X3U411WB6

1	Boot
2	Wheel cylinder piston
3	Piston cup
4	Wheel cylinder spring

5	Bleeder cap
6	Bleeder screw (See 04-11-21 Bleeder Screw Assembly Note)
7	Wheel cylinder body

# 04-12 PARKING BRAKE SYSTEM

**PARKING BRAKE SYSTEM**  
**LOCATION INDEX** ..... 04-12-1  
**PARKING BRAKE (LEVER TYPE)**  
**INSPECTION**..... 04-12-1

**PARKING BRAKE (LEVER TYPE)**  
**ADJUSTMENT** .....04-12-1  
**PARKING BRAKE (LEVER TYPE)**  
**REMOVAL/INSTALLATION**.....04-12-2

## PARKING BRAKE SYSTEM LOCATION INDEX

A3U041244000W01

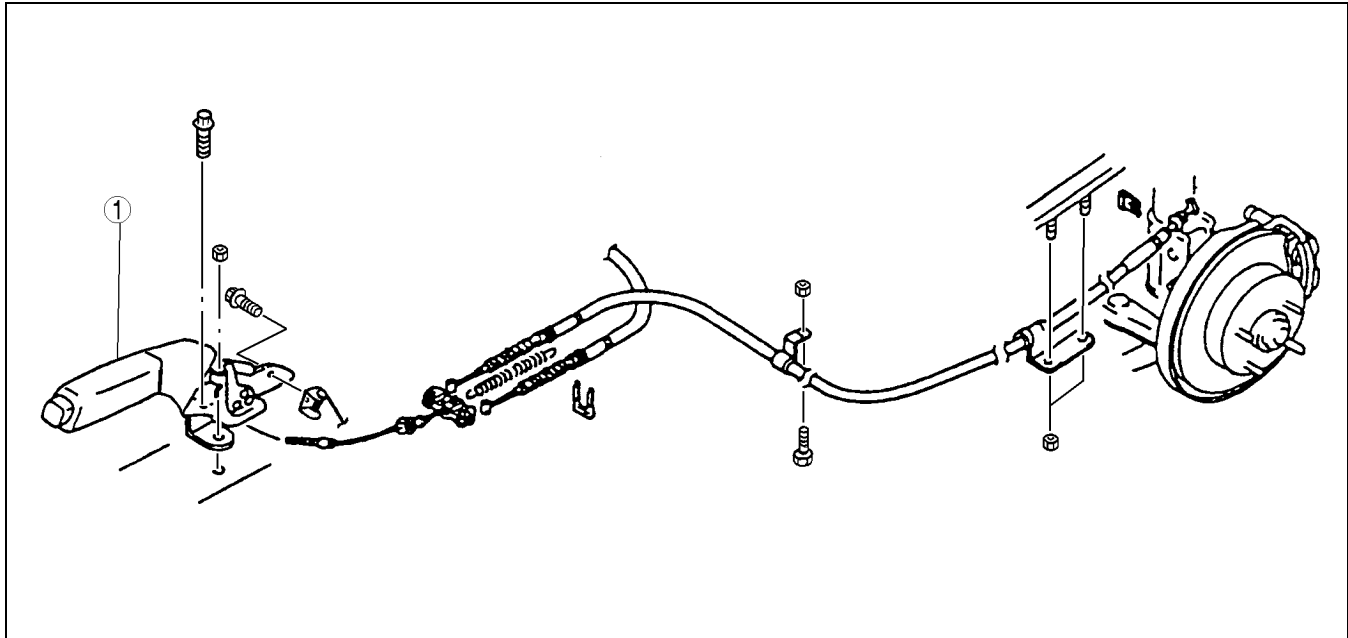

A3U0412W001

1	Parking brake (See 04-12-1 PARKING BRAKE (LEVER TYPE) INSPECTION) (See 04-12-1 PARKING BRAKE (LEVER TYPE) ADJUSTMENT) (See 04-12-2 PARKING BRAKE (LEVER TYPE) REMOVAL/INSTALLATION)
---	--

## PARKING BRAKE (LEVER TYPE) INSPECTION

A3U041244000W02

1. Pull the parking brake lever a few times.
2. Depress the brake pedal a few times.
3. Inspect the parking brake stroke by pulling the parking brake lever with a force of **98 N {10 kgf, 22 lbf}**.

**Stroke**  
**5—7 notches**

## PARKING BRAKE (LEVER TYPE) ADJUSTMENT

A3U041244000W03

1. Start the engine and depress the brake pedal several times.
2. Stop the engine.
3. Turn the adjusting nut at the front of the parking cable.
4. After adjustment, inspect the following points:
  - (1) Turn the ignition switch to ON, pull the parking brake lever one notch, and verify that the parking brake warning light illuminates.
  - (2) Verify that the rear brakes do not drag.

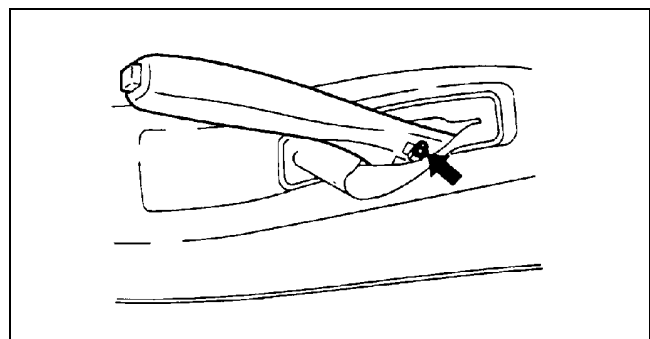

X3U412WAO

# PARKING BRAKE SYSTEM

## PARKING BRAKE (LEVER TYPE) REMOVAL/INSTALLATION

A3U04124400W04

1. Remove the rear console. (See 09-17-5 CONSOLE REMOVAL/INSTALLATION.)
2. Remove the exhaust pipe insulator bolts.
3. Remove in the order indicated in the table.
4. Install in the reverse order of removal.
5. Adjust the parking brake stroke. (See 04-12-1 PARKING BRAKE (LEVER TYPE) ADJUSTMENT.)

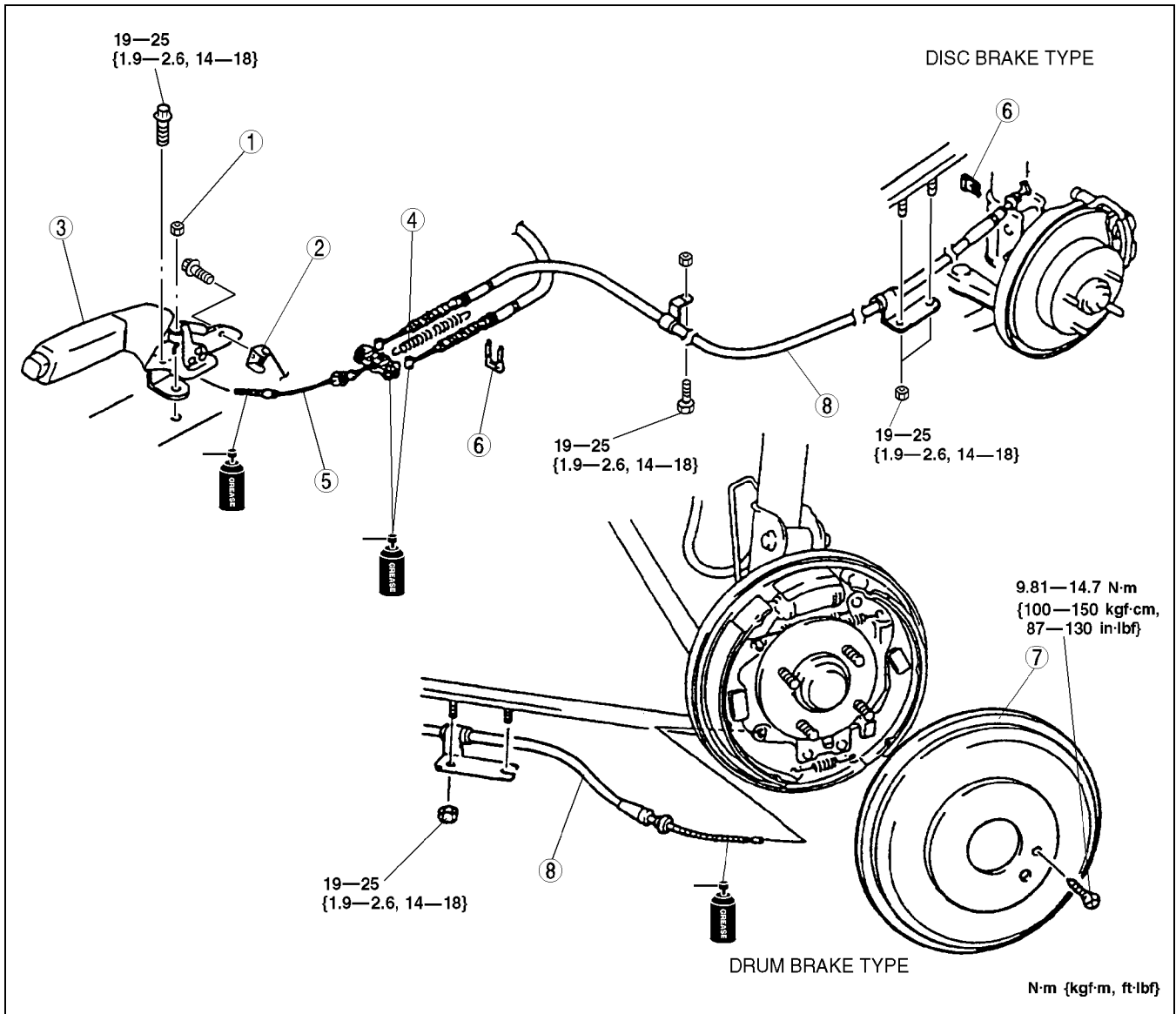

A3U0412W002

1	Adjusting nut
2	Parking brake switch
3	Parking brake lever
4	Return spring

5	Front cable and equalizer
6	Clip
7	Brake drum
8	Parking brake cable



# 04-13 ANTILOCK BRAKE SYSTEM

**ABS LOCATION INDEX** ..... 04-13-1

**ABS SYSTEM DIAGRAM** ..... 04-13-2

**ABS HYDRAULIC UNIT (HU)/  
CONTROL MODULE (CM)**

**SYSTEM INSPECTION** ..... 04-13-3

    System Inspection ..... 04-13-3

    Using the SSTs ..... 04-13-3

    Without using the SSTs ..... 04-13-4

**ABS HYDRAULIC UNIT (HU)/  
CONTROL MODULE (CM)**

**REMOVAL/INSTALLATION** ..... 04-13-5

    Connector Removal Note..... 04-13-6

    ABS HU/CM Removal/Installation Note 04-13-6

    Connector Installation Note ..... 04-13-6

**ABS HYDRAULIC UNIT (HU)/  
CONTROL MODULE (CM)**

**INSPECTION** ..... 04-13-6

    Terminal Voltage Table (Reference) . . . 04-13-6

    Inspection Using An Oscilloscope  
    (Reference) ..... 04-13-8

**FRONT ABS WHEEL-SPEED SENSOR  
REMOVAL/INSTALLATION**..... 04-13-9

**FRONT/REAR ABS WHEEL-SPEED  
SENSOR INSPECTION** ..... 04-13-9

    Visual Inspection ..... 04-13-9

    Clearance Inspection ..... 04-13-9

    Resistance Inspection ..... 04-13-9

    Voltage Inspection..... 04-13-10

    Voltage Pattern Inspection ..... 04-13-10

**REAR ABS WHEEL-SPEED SENSOR  
REMOVAL/INSTALLATION**..... 04-13-10

**04-13**

**ABS LOCATION INDEX**

A3U041343000W01

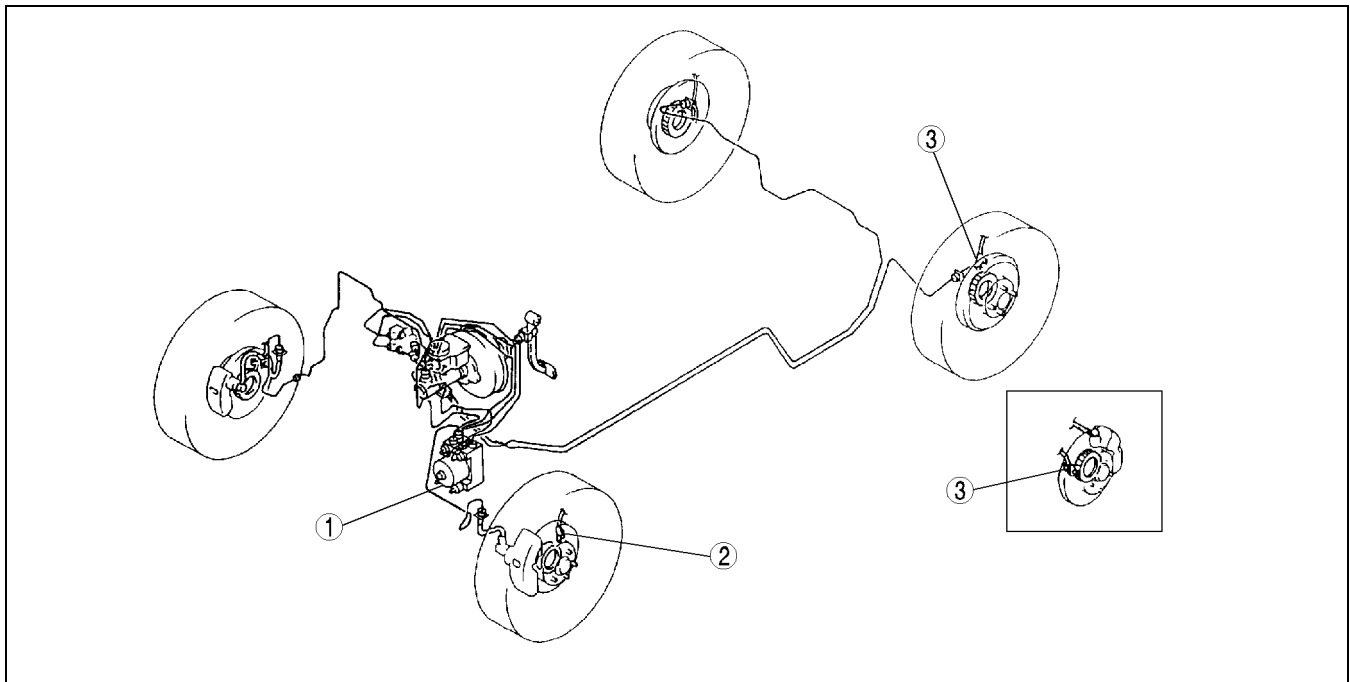

Z3U0413W101

1	ABS HU/CM (See 04-13-3 ABS HYDRAULIC UNIT (HU)/ CONTROL MODULE (CM) SYSTEM INSPECTION) (See 04-13-5 ABS HYDRAULIC UNIT (HU)/ CONTROL MODULE (CM) REMOVAL/ INSTALLATION) (See 04-13-6 ABS HYDRAULIC UNIT (HU)/ CONTROL MODULE (CM) INSPECTION)
---	--

2	ABS wheel-speed sensor (front) (See 04-13-9 FRONT ABS WHEEL-SPEED SENSOR REMOVAL/INSTALLATION) (See 04-13-9 FRONT/REAR ABS WHEEL-SPEED SENSOR INSPECTION)
3	ABS wheel-speed sensor (rear) (See 04-13-10 REAR ABS WHEEL-SPEED SENSOR REMOVAL/INSTALLATION) (See 04-13-9 FRONT/REAR ABS WHEEL-SPEED SENSOR INSPECTION)

# ANTILOCK BRAKE SYSTEM

## ABS SYSTEM DIAGRAM

A3U04134300W02

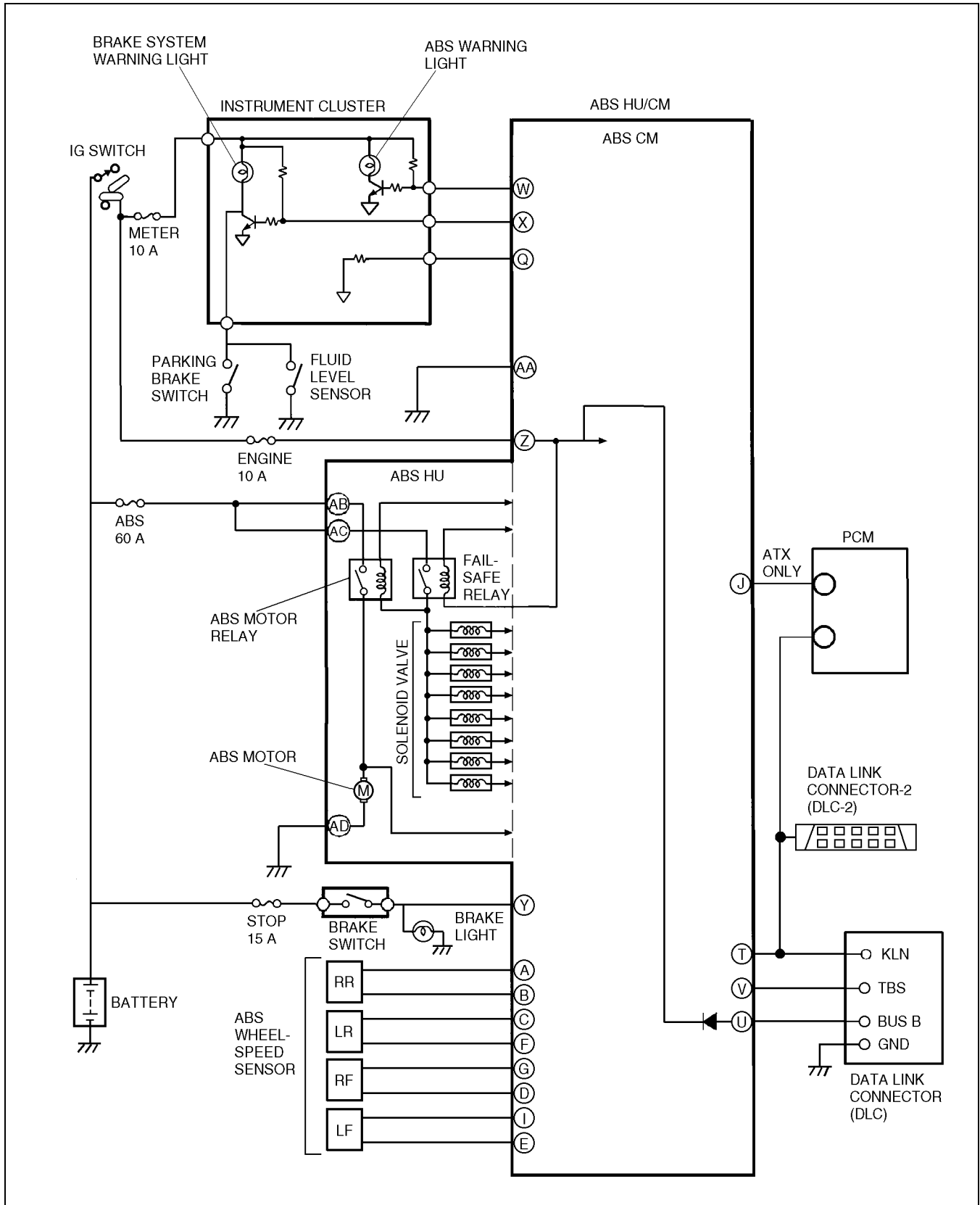

A3U0402W001

# ANTILOCK BRAKE SYSTEM

## ABS HYDRAULIC UNIT (HU)/CONTROL MODULE (CM) SYSTEM INSPECTION

A3U041343780W01

### System Inspection

#### Preparation

1. Verify that the battery is fully charged. With the ignition switch on, verify that the ABS and BRAKE system warning lights goes out after **3 seconds**.
2. If the lights stays on after **3 seconds**, the ABS HU/CM detects a failure. Follow the troubleshooting procedures.
3. Turn the ignition switch off.
4. On level ground, jack up the vehicle and support it evenly on safety stands. Shift the transaxle to N position.
5. Release the parking brake.
6. Rotate the wheels by hand, and inspect for brake drag.

#### Using the SSTs

1. Perform the "Preparation."
2. Connect the **SSTs** (WDS or equivalent) to the data link connector-2 (DLC-2).
3. Set up an active command mode inspection according to the combination of commands below. (See 04-02-3 ABS ON-BOARD DIAGNOSTIC.)

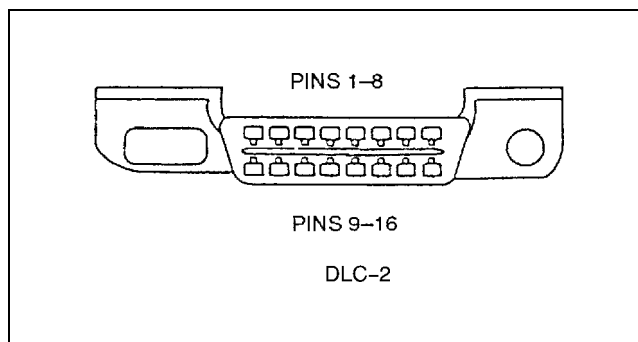

X3U101WA1

04-13

OPERATION	COMMAND NAME				COMMAND TYPE
	PMP_MOTOR	RF_OUTLET	RF_INLET	ABS_POWER	
Pressure retention	OFF	OFF	ON	ON	Manual
Pressure reduction	ON	ON	ON	ON	

The chart above shows an example of a right wheel inspection.

#### Note

- When working with two people, one should press on the brake pedal, the other should attempt to rotate the wheel being inspected.

4. Send the command while pressing on the brake pedal and attempting to rotate the wheel being inspected.
5. When pressure is being maintained, and click sound indicating the solenoid is operating comes from the ABS HU/CM, confirm that the wheel does not rotate. When pressure is being reduced, and click sound indicating the solenoid is operating comes from the ABS HU/CM, confirm that the wheel rotates, even though the brake pedal is being depressed.

#### Note

- To protect the ABS HU/CM, the solenoid valve used for simulations and the ABS motor stay on for **10 seconds** each time they are switched on.
- Performing the inspections above determines the following.
  - The ABS HU/CM brake lines are normal.
  - The ABS HU/CM hydraulic system is not significantly abnormal.
  - The ABS HU/CM wiring is normal.
- However, the following items cannot be checked.
  - ABS HU/CM input system harness and parts
  - Extremely small leaks in the ABS HU/CM internal hydraulic system
  - Unusual intermittent occurrences in the above items

# ANTILOCK BRAKE SYSTEM

## Without using the SSTs

1. Perform the "Preparation."

### Caution

- Connecting the wrong data link connector (DLC) terminal may possibly cause a malfunction. Carefully connect the specified terminal only.

2. Use a jumper wire to short terminal TBS of the DLC to body GND.
3. Depress the brake pedal, and have an assistant verify that the right front wheel does not turn.
4. With the brake pedal still depressed, turn the ignition switch on and verify that the brake is released momentarily (**approx. 0.5 sec.**) and that the wheel turns when pressure-reduction operates.
5. Inspect the operation of the remaining wheels in order: right front, left front, right rear, left rear.
  - Replace the ABS HU/CM if wheels do not rotate.
  - Inspect brake piping to ABS HU/CM if operation of the remaining wheel order is not within specified.

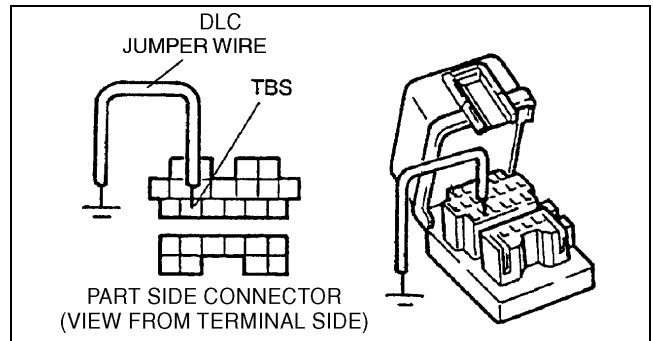

Y3U413WA3

### Note

- If Steps 4 and 5 show correct operation, the following systems are okay:
  - Brake piping to ABS HU/CM
  - Braking system, including ABS HU/CM
  - Electrical system in ABS HU/CM (solenoid, ABS motor, etc.)
- The following are not inspected with above steps:
  - Input system and harness of ABS HU/CM
  - Intermittent failure
  - Fluid leakage from brake including the ABS HU/CM and master cylinder

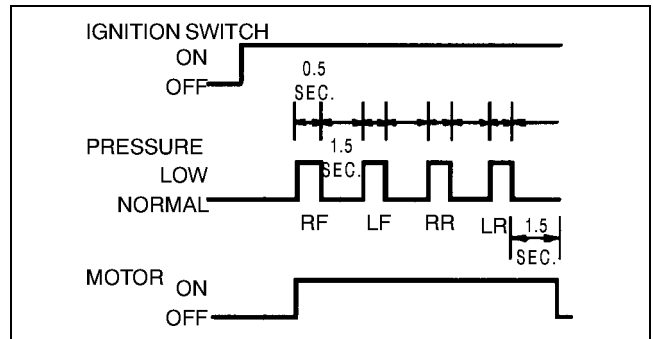

YMU413WA7

6. Turn the ignition switch off and remove the jumper wire.

# ANTILOCK BRAKE SYSTEM

## ABS HYDRAULIC UNIT (HU)/CONTROL MODULE (CM) REMOVAL/INSTALLATION

A3U041343700W01

### Caution

- Do not drop the ABS hydraulic unit (HU) /control module (CM). Replace it if it is subjected to an impact.

- Remove the battery and battery tray.
- Remove in the order indicated in the table.
- Install in the reverse order of removal.

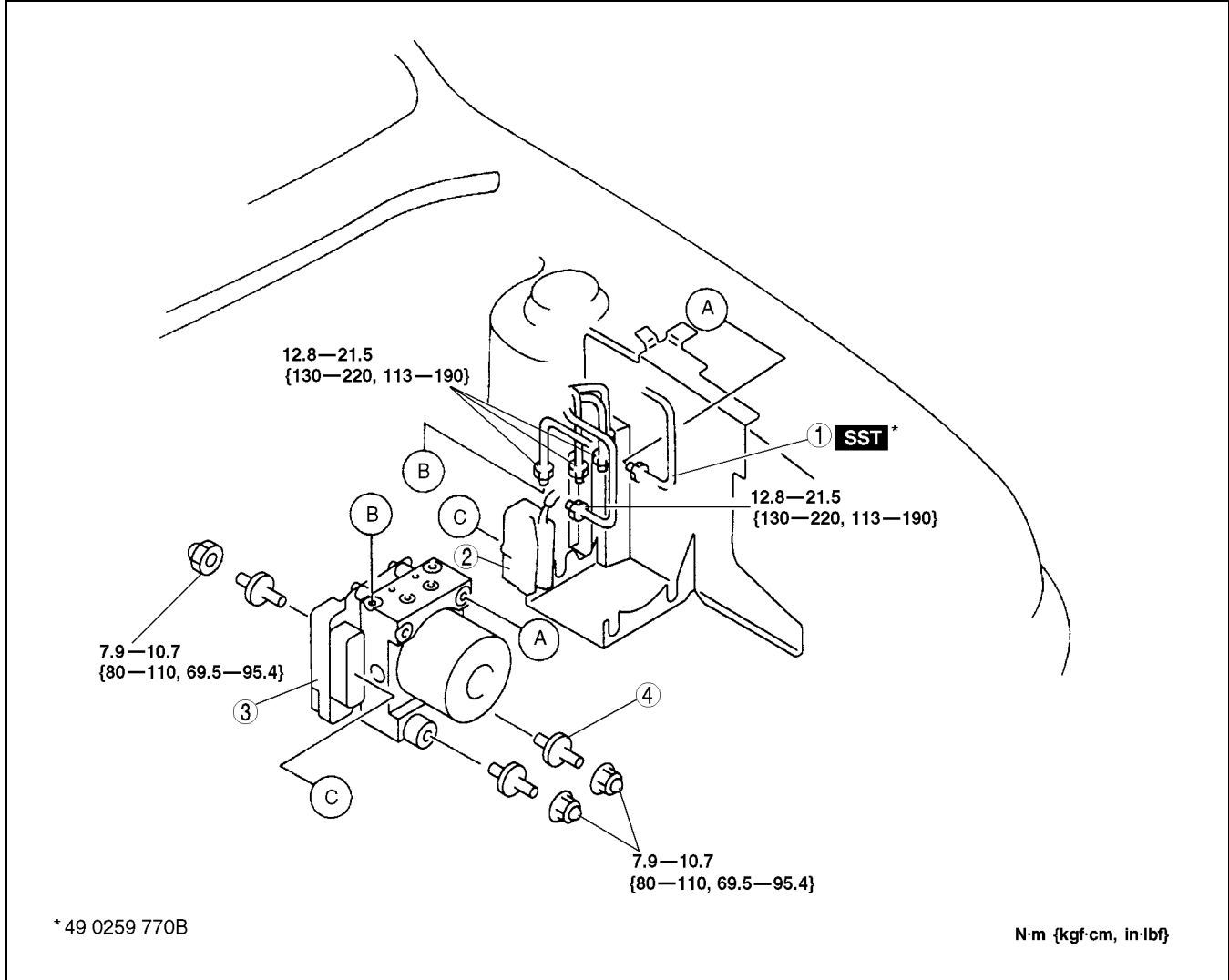

A3U0413W101

1	Brake pipe
2	Connector (See 04-13-6 Connector Removal Note) (See 04-13-6 Connector Installation Note)

3	ABS HU/CM (See 04-13-6 ABS HU/CM Removal/Installation Note)
4	stud

04-13

# ANTILOCK BRAKE SYSTEM

## Connector Removal Note

1. Pull the lock lever up and make it unlock.
2. Remove the connector.

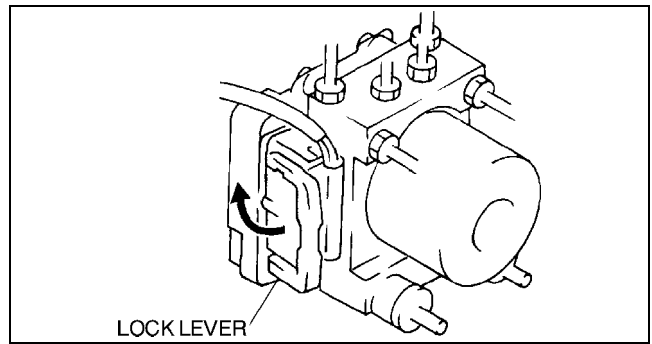

YMU413WC8

## ABS HU/CM Removal/Installation Note

1. When removing/installing the ABS HU/CM from/to the vehicle, attach a strip of protective tape on the ABS HU/CM connector to prevent brake fluid from entering.

## Connector Installation Note

1. Verify that the lock lever of the harness connector is completely pulled up.

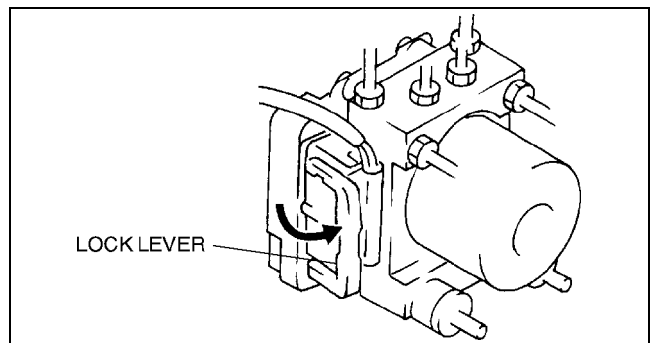

YMU413WC9

## ABS HYDRAULIC UNIT (HU)/CONTROL MODULE (CM) INSPECTION

A3U041367650W01

1. Disconnect the negative battery cable.
2. Connect the **SST** between the ABS HU/CM and harness connector with the ignition switch off.
3. Attach the tester leads to the **SST** and inspect voltage referring the table below.

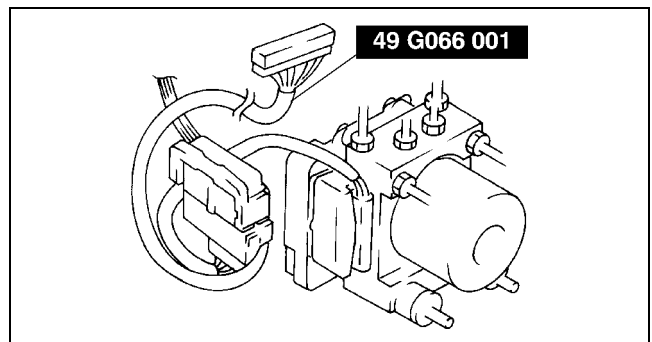

YMU413WA3

## Terminal Voltage Table (Reference)

(Engine is idling, and connector is connected unless otherwise indicated)

ABS HU/CM													SST (49 G066 001) CONNECTOR													
A	D	G	J	M	P	S	V	Y					AA	AC												
B	E	H						Q	T	W			P	O	M	L	J	I	H	G	F	E	D	C	B	A
C	F	I	L	O	R	U	X	Z																		

HARNESS SIDE CONNECTOR  
(VIEW FROM TERMINAL SIDE)

(VIEW FROM TERMINAL SIDE)

Y3U402WA8

## ANTILOCK BRAKE SYSTEM

Terminal	Signal	Connected to	Test condition	Voltage (V)	Action				
A B	RR wheel-speed	RR wheel-speed sensor	Vehicle is stopped	0 (AC)	<ul style="list-style-type: none"> <li>Inspect related harness</li> <li>Inspect ABS wheel-speed sensor</li> </ul>				
			<ul style="list-style-type: none"> <li>Inspect by using the wave profile. (See 04-13-8 Inspection Using An Oscilloscope (Reference))</li> </ul>						
C F	LR wheel-speed	LR wheel-speed sensor	Vehicle is stopped	0 (AC)		<ul style="list-style-type: none"> <li>Inspect related harness</li> <li>Inspect ABS wheel-speed sensor</li> </ul>			
			<ul style="list-style-type: none"> <li>Inspect by using the wave profile. (See 04-13-8 Inspection Using An Oscilloscope (Reference))</li> </ul>						
D G	RF wheel-speed	RF wheel-speed sensor	Vehicle is stopped	0 (AC)			<ul style="list-style-type: none"> <li>Inspect related harness</li> <li>Inspect ABS wheel-speed sensor</li> </ul>		
			<ul style="list-style-type: none"> <li>Inspect by using the wave profile. (See 04-13-8 Inspection Using An Oscilloscope (Reference))</li> </ul>						
E I	LF wheel-speed	LF wheel-speed sensor	Vehicle is stopped	0 (AC)				<ul style="list-style-type: none"> <li>Inspect related harness</li> <li>Inspect ABS wheel-speed sensor</li> </ul>	
			<ul style="list-style-type: none"> <li>Inspect by using the wave profile. (See 04-13-8 Inspection Using An Oscilloscope (Reference))</li> </ul>						
H	—	—	—	—					—
J*1	Vehicle speed output	PCM	Vehicle is stopped	0					<ul style="list-style-type: none"> <li>Inspect related harness</li> <li>Inspect ABS wheel-speed sensor</li> </ul>
			<ul style="list-style-type: none"> <li>Inspect by using the wave profile. (See 04-13-8 Inspection Using An Oscilloscope (Reference))</li> </ul>						
L	—	—	—	—	—				
M	—	—	—	—	—				
O	—	—	—	—	—				
P	—	—	—	—	—				
Q	Vehicle speed output	Instrument cluster	Vehicle is stopped	0	<ul style="list-style-type: none"> <li>Inspect related harness</li> <li>Inspect ABS wheel-speed sensor</li> </ul>				
			<ul style="list-style-type: none"> <li>Inspect by using the wave profile. (See 04-13-8 Inspection Using An Oscilloscope (Reference))</li> </ul>						
R	—	—	—	—		—			
S	—	—	—	—		—			
T	On-board diagnosis	KLN terminal of DLC and DLC-2	—	No need to check		—			
U*2	—	DLC	—	No need to check		—			
V	On-board diagnosis	TBS terminal of DLC	—	10—14		<ul style="list-style-type: none"> <li>Inspect related harness</li> </ul>			
W	ABS warning light	ABS warning light	Illuminated	Below 0.5		<ul style="list-style-type: none"> <li>Inspect related harness</li> </ul>			
			Not illuminated	Above 1.5					
X	Brake system warning light	Brake system warning light	Illuminated	Below 0.5		<ul style="list-style-type: none"> <li>Inspect related harness</li> </ul>			
			Not illuminated	Above 1.5					
Y	Brake switch	Brake switch	Brake pedal is depressed	10—14	<ul style="list-style-type: none"> <li>Inspect related harness</li> </ul>				
			Brake pedal is released	Below 0.5					
Z	Power supply	Ignition switch	—	B+	<ul style="list-style-type: none"> <li>Inspect related harness</li> </ul>				
AA	Ground	Ground	—	0	<ul style="list-style-type: none"> <li>Inspect related harness</li> </ul>				
AB	Power supply (ABS motor)	Battery	—	B+	<ul style="list-style-type: none"> <li>Inspect related harness</li> </ul>				
AC	Power supply (Solenoid valve)	Battery	—	B+					
AD	Ground	Ground	—	0	<ul style="list-style-type: none"> <li>Inspect related harness</li> </ul>				

\*1 : ATX only

\*2 : Use this terminal at factory only, not used for inspection and repair at field

# ANTILOCK BRAKE SYSTEM

## Inspection Using An Oscilloscope (Reference)

### Wheel speed

- ABS HU/CM terminal:  
RR : A (+) — B (-)  
LR : C (+) — F (-)  
RF : D (+) — G (-)  
LF : E (+) — I (-)
- Oscilloscope setting:  
1 V/DIV (Y), 2 ms/DIV (X), AC range
- Vehicle condition: Driving 30 km/h (18.6 mph)

#### Note

- As vehicle speed increases, period of wave shortens.
- If there is malfunctioning in the sensor rotor, wave profile warps.

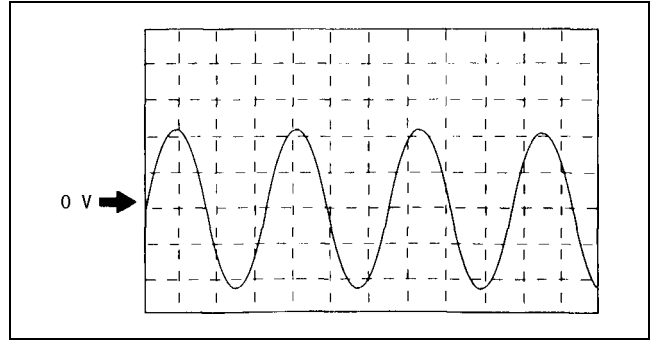

Z3U0413W201

### Vehicle speed output (to PCM) (ATX only)

- ABS HU/CM terminal: J (+) — AA (-)
- Oscilloscope setting:  
1 V/DIV (Y), 5 ms/DIV (X), DC range
- Vehicle condition: Driving 30 km/h (18.6 mph)

#### Note

- As vehicle speed increases, period of wave shortens.

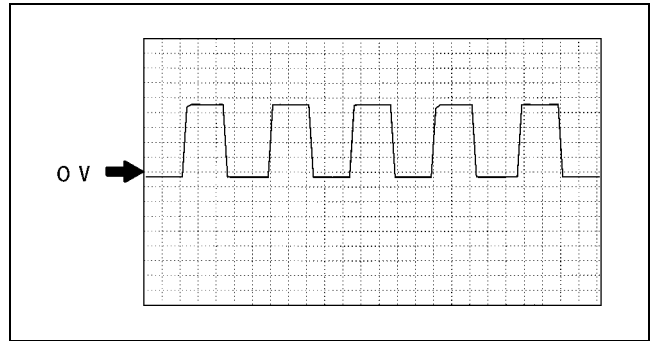

Z3U0413W202

### Vehicle speed output (to instrument cluster)

- ABS HU/CM terminal: Q (+) — AA (-)
- Oscilloscope setting:  
1 V/DIV (Y), 5 ms/DIV (X), DC range
- Vehicle condition: Driving 30 km/h (18.6 mph)

#### Note

- As vehicle speed increases, period of wave shortens.

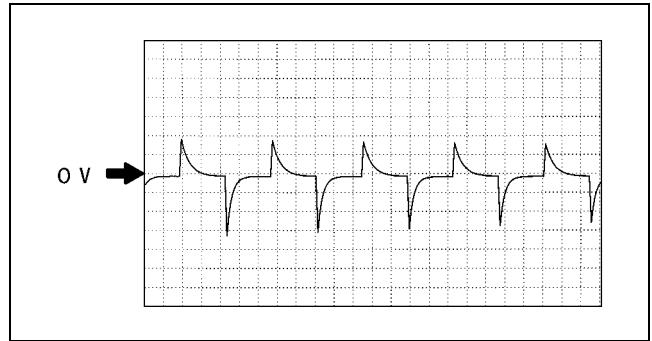

Z3U0413W203



# ANTILOCK BRAKE SYSTEM

## FRONT ABS WHEEL-SPEED SENSOR REMOVAL/INSTALLATION

A3U041343720W01

1. Remove in the order indicated in the table.
2. Install in the reverse order of removal.

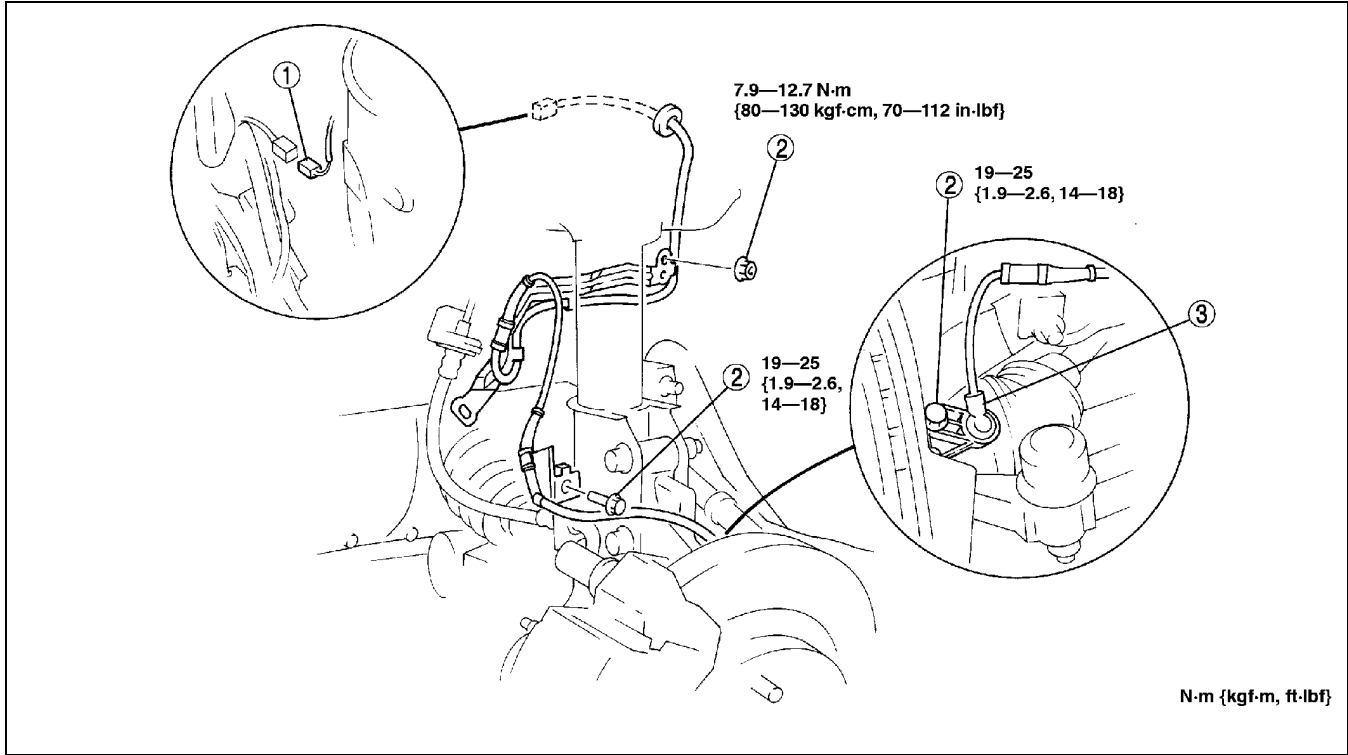

X3U413WAB

1	Connector
2	Bolt, nut

3	Front ABS wheel-speed sensor
---	------------------------------

## FRONT/REAR ABS WHEEL-SPEED SENSOR INSPECTION

A3U041343720W02

### Visual Inspection

1. Remove the wheel and tire, and inspect the sensor for looseness and damage. Replace the sensor if necessary.

### Clearance Inspection

1. Inspect the clearance between the wheel-speed sensor and the sensor rotor.

#### Clearance

0.3—1.1 mm {0.012—0.043 in}

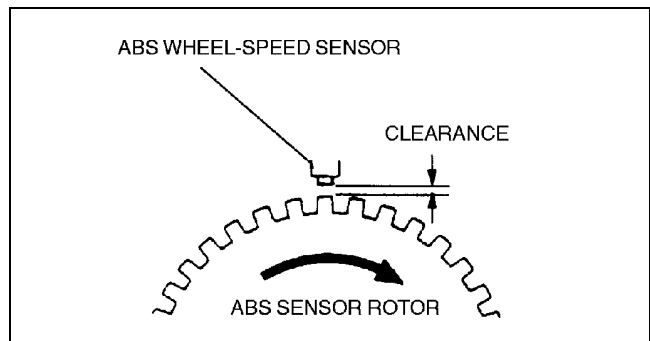

X3U413WAC

### Resistance Inspection

1. Disconnect the ABS wheel-speed sensor connector.
2. Inspect the resistance at the ABS wheel-speed sensor.
  - If not as specified, replace the ABS wheel-speed sensor.

#### Resistance

1.3—1.7 kilohm

04-13

# ANTILOCK BRAKE SYSTEM

## Voltage Inspection

1. On level ground, jack up the vehicle and support it evenly on safety stands.
2. Disconnect the ABS wheel-speed sensor connector.
3. Inspect each sensor by rotating each wheel one revolution per second.
  - If not as specified, replace the ABS wheel-speed sensor.

## Voltage

0.25—1.2 V (AC)

## Voltage Pattern Inspection

1. On level ground, jack up the vehicle and support it evenly on safety stands.
2. Disconnect the ABS wheel-speed sensor connector.
3. Using an oscilloscope, inspect voltage pattern for distortion and noise by rotating each wheel.
  - If there is distortion or noise, inspect the ABS sensor rotor.

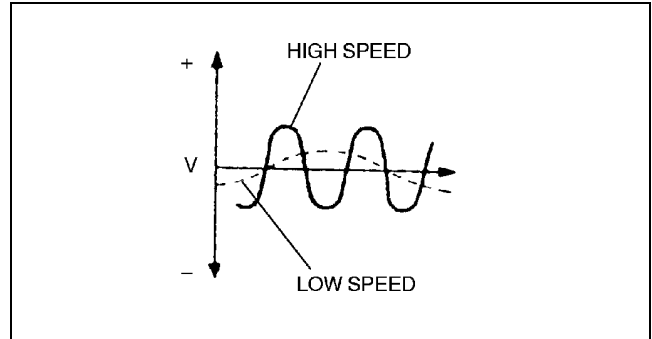

X3U413WAD

## REAR ABS WHEEL-SPEED SENSOR REMOVAL/INSTALLATION

A3U041343710W01

1. For 4SD, remove the rear seat back. (See 09-13-5 REAR SEAT REMOVAL/INSTALLATION.)  
For 5HB, remove the trunk side trim. (See 09-17-15 5HB.)
2. Remove in the order indicated in the table.
3. Install in the reverse order of removal.

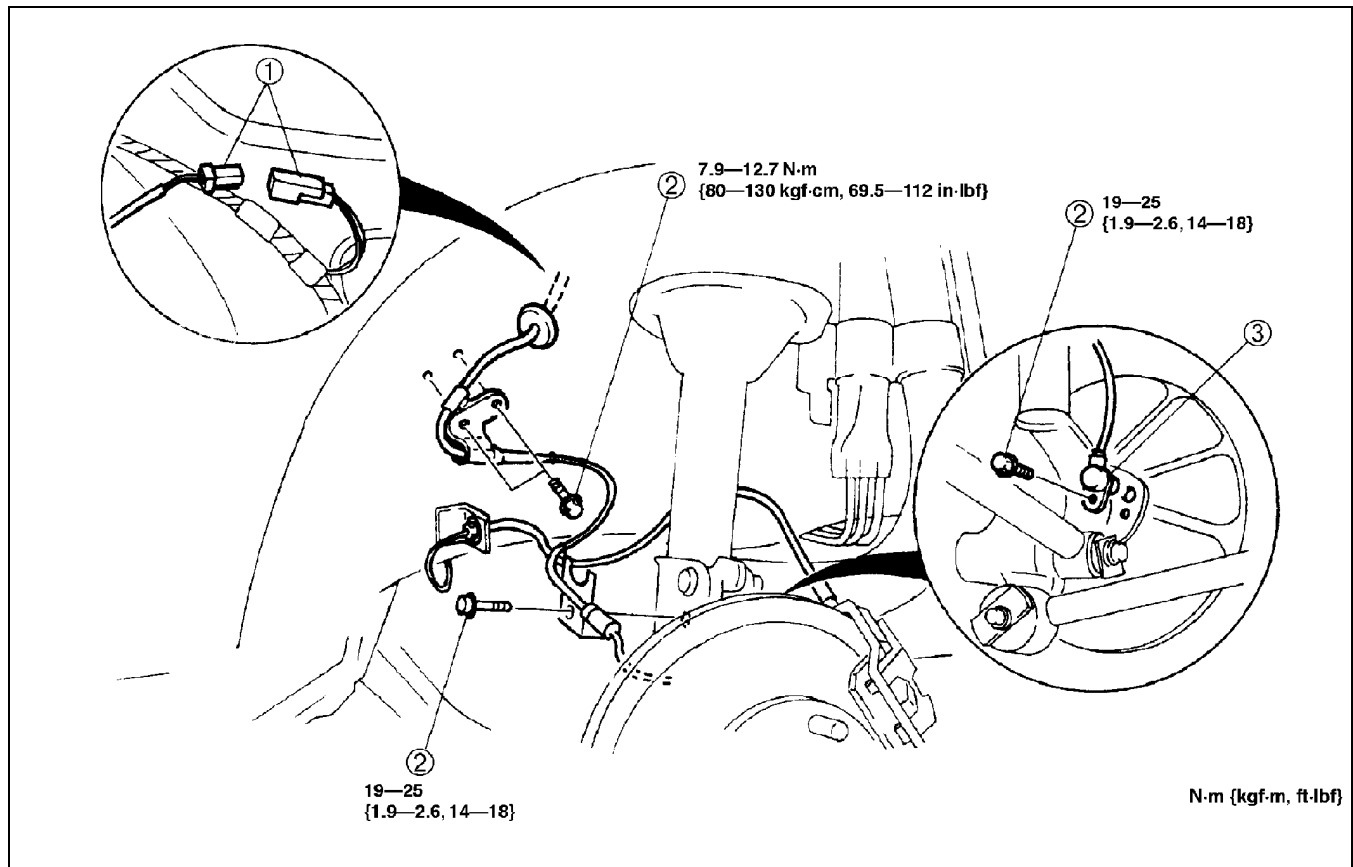

X3U413WAE

1	Connector
2	Bolt

3	Rear ABS wheel-speed sensor
---	-----------------------------

# TECHNICAL DATA

## 04-50 TECHNICAL DATA

BRAKES TECHNICAL DATA . . . . . 04-50-1

### BRAKES TECHNICAL DATA

A3U045001020W01

Item		ZM engine	FS engine
<b>CONVENTIONAL BRAKE SYSTEM</b>			
Brake pedal	Brake pedal height (mm {in})	185 {7.28} (reference value)	
	Brake pedal play (mm {in})	4—12 {0.16—0.47}	
	Pedal-to-floor clearance (Brake pedal when depressed at 588 N {60 kgf, 132 lbf}) (mm {in})	88 {3.5} min.	84 {3.3} min.
Power brake unit	Fluid pressure (kPa {kgf/cm <sup>2</sup> , psi})	At 0 kPa {0 mmHg, 0 inHg}	650 {7, 94} min.
		At 66.7 kPa {500 mmHg, 19.7 inHg}	6,500 {66, 943} min.
Dual proportioning valve (without ABS)	Switching point (kPa {kgf/cm <sup>2</sup> , psi})	2,900 {30, 430} ±200 {2, 30}	3,400 {35, 500} ±300 {3, 40}
	Rear wheel pressure when master cylinder pressure is 5900 kPa {60 kgf/cm <sup>2</sup> , 850 psi} (kPa {kgf/cm <sup>2</sup> , psi})	3,800 {39, 550} ±300 {3, 40}	4,200 {42.5, 600} ±400 {4, 60}
Front disc brake	Minimum disc pad thickness (mm {in})	1.5 {0.059}	2.0 {0.079}
	Minimum disc plate thickness (mm {in})	20 {0.78}	22 {0.87}
	Disc plate runout limit (mm {in})	0.05 {0.002}	
Rear disc brake	Minimum disc pad thickness (mm {in})	—	1.0 {0.039}
	Minimum disc plate thickness (mm {in})		8 {0.31}
	Disc plate runout limit (mm {in})		0.05 {0.002}
Rear drum brake	Maximum brake drum diameter (mm {in})	201.5 {7.933}	—
	Minimum lining thickness (mm {in})	1.0 {0.039}	
	Clearance between shoe and drum	Automatic adjuster	
Brake fluid	Type	SAE J1703 or FMVSS 116 DOT3	
<b>PARKING BRAKE SYSTEM</b>			
Parking brake lever	Lever stroke when pulled at 98 N {10 kgf, 22 lbf} (notches)	5—7	

04-50



# SERVICE TOOLS

## 04-60 SERVICE TOOLS

**BRAKES SST** ..... 04-60-1

### BRAKES SST

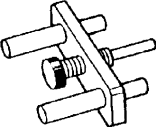
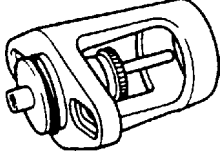
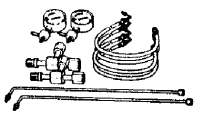
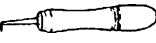
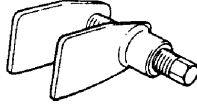
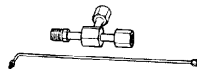
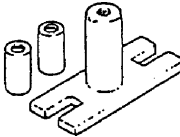
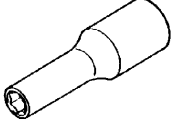
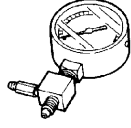
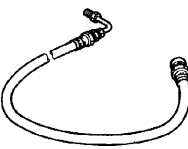
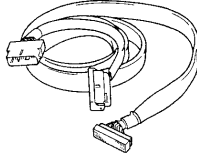
A3U046001020W01

<p>49 0259 770B</p> <p>Flare nut wrench</p> 	<p>49 F043 001</p> <p>Adjust gauge</p> 	<p>49 B043 001</p> <p>Adjust gauge</p> 
<p>49 U043 0A0A</p> <p>Oil pressure gauge set</p> 	<p>49 0208 701A</p> <p>Boot air-out tool</p> 	<p>49 0221 600C</p> <p>Disc brake expand tool</p> 
<p>49 U043 005</p> <p>Joint (Part of 49 U043 0A0A)</p> 	<p>49 E043 003A</p> <p>Turning lock tool</p> 	<p>49 B043 004</p> <p>Socket wrench</p> 
<p>49 U043 004</p> <p>Oil pressure gauge (Part of 49 U043 0A0A)</p> 	<p>49 U043 006</p> <p>Hose (Part of 49 U043 0A0A)</p> 	<p>49 G066 001</p> <p>Adapter harness</p> 
<p>418FS475</p> <p>WDS</p> 	<p style="text-align: center;">—</p>	<p style="text-align: center;">—</p>

04-60

# TRANSMISSION/TRANSAXLE

**05**  
SECTION

<b>ON-BOARD DIAGNOSTIC . . . . .05-02</b>	<b>MANUAL TRANSAXLE</b>
<b>SYMPTOM</b>	<b>SHIFT MECHANISM . . . . . 05-16</b>
<b>TROUBLESHOOTING . . . . .05-03</b>	<b>AUTOMATIC TRANSAXLE . . . 05-17</b>
<b>CLUTCH . . . . .05-10</b>	<b>AUTOMATIC TRANSAXLE</b>
<b>MANUAL TRANSAXLE</b>	<b>SHIFT MECHANISM . . . . . 05-18</b>
<b>[F25M-R] . . . . .05-15A</b>	<b>TECHNICAL DATA . . . . . 05-50</b>
<b>MANUAL TRANSAXLE</b>	<b>SERVICE TOOLS . . . . . 05-60</b>
<b>[G15M-R] . . . . .05-15B</b>	

**05-02**

## 05-02 ON-BOARD DIAGNOSTIC

<b>AUTOMATIC TRANSAXLE CONTROL SYSTEM</b>	<b>DTC P0742 . . . . . 05-02-33</b>
<b>WIRING DIAGRAM . . . . .05-02-2</b>	<b>DTC P0745 . . . . . 05-02-36</b>
<b>FOREWARD . . . . .05-02-6</b>	<b>DTC P0751 . . . . . 05-02-38</b>
<b>AUTOMATIC TRANSAXLE ON-BOARD</b>	<b>DTC P0752 . . . . . 05-02-40</b>
<b>DIAGNOSTIC FUNCTION . . . . .05-02-6</b>	<b>DTC P0753 . . . . . 05-02-42</b>
<b>DTC Reading Procedure . . . . .05-02-6</b>	<b>DTC P0756 . . . . . 05-02-44</b>
<b>AFTER REPAIR PROCEDURE . . . . .05-02-6</b>	<b>DTC P0757 . . . . . 05-02-46</b>
<b>DTC TABLE . . . . .05-02-7</b>	<b>DTC P0758 . . . . . 05-02-48</b>
<b>DTC P0500 . . . . .05-02-10</b>	<b>DTC P0761 . . . . . 05-02-50</b>
<b>DTC P0705 . . . . .05-02-14</b>	<b>DTC P0762 . . . . . 05-02-52</b>
<b>DTC P0706 . . . . .05-02-16</b>	<b>DTC P0763 . . . . . 05-02-54</b>
<b>DTC P0710 . . . . .05-02-18</b>	<b>DTC P0766 . . . . . 05-02-56</b>
<b>DTC P0711 . . . . .05-02-21</b>	<b>DTC P0767 . . . . . 05-02-58</b>
<b>DTC P0715 . . . . .05-02-22</b>	<b>DTC P0768 . . . . . 05-02-60</b>
<b>DTC P0731 . . . . .05-02-24</b>	<b>DTC P0771 . . . . . 05-02-62</b>
<b>DTC P0732 . . . . .05-02-26</b>	<b>DTC P0772 . . . . . 05-02-64</b>
<b>DTC P0733 . . . . .05-02-28</b>	<b>DTC P0773 . . . . . 05-02-66</b>
<b>DTC P0734 . . . . .05-02-30</b>	<b>PID/DATA MONITOR INSPECTION . . . . 05-02-68</b>
<b>DTC P0741 . . . . .05-02-32</b>	

# ON-BOARD DIAGNOSTIC

## AUTOMATIC TRANSAXLE CONTROL SYSTEM WIRING DIAGRAM

A3U050201030W01

ZM Engine

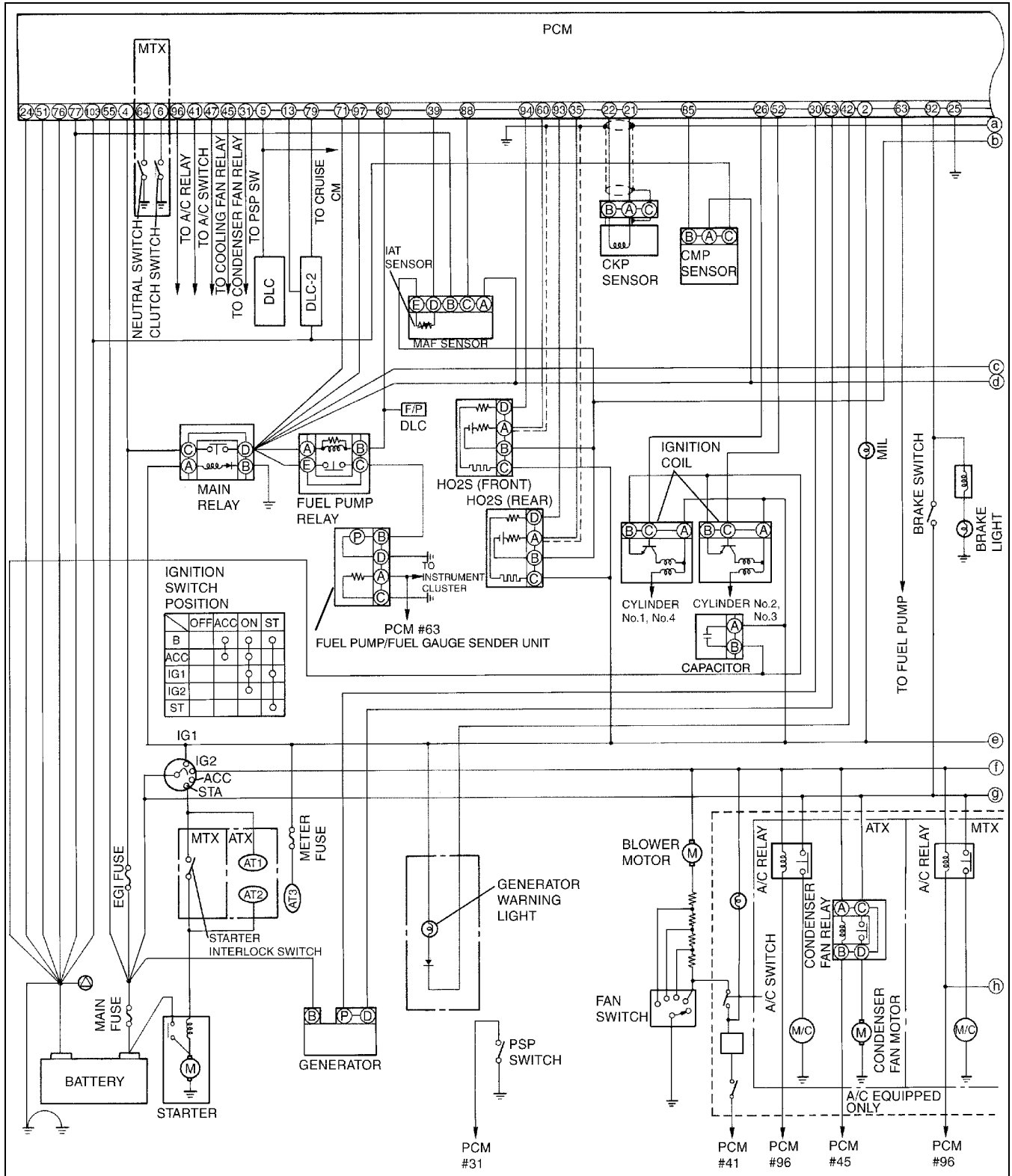

Y3U502WA0

# ON-BOARD DIAGNOSTIC

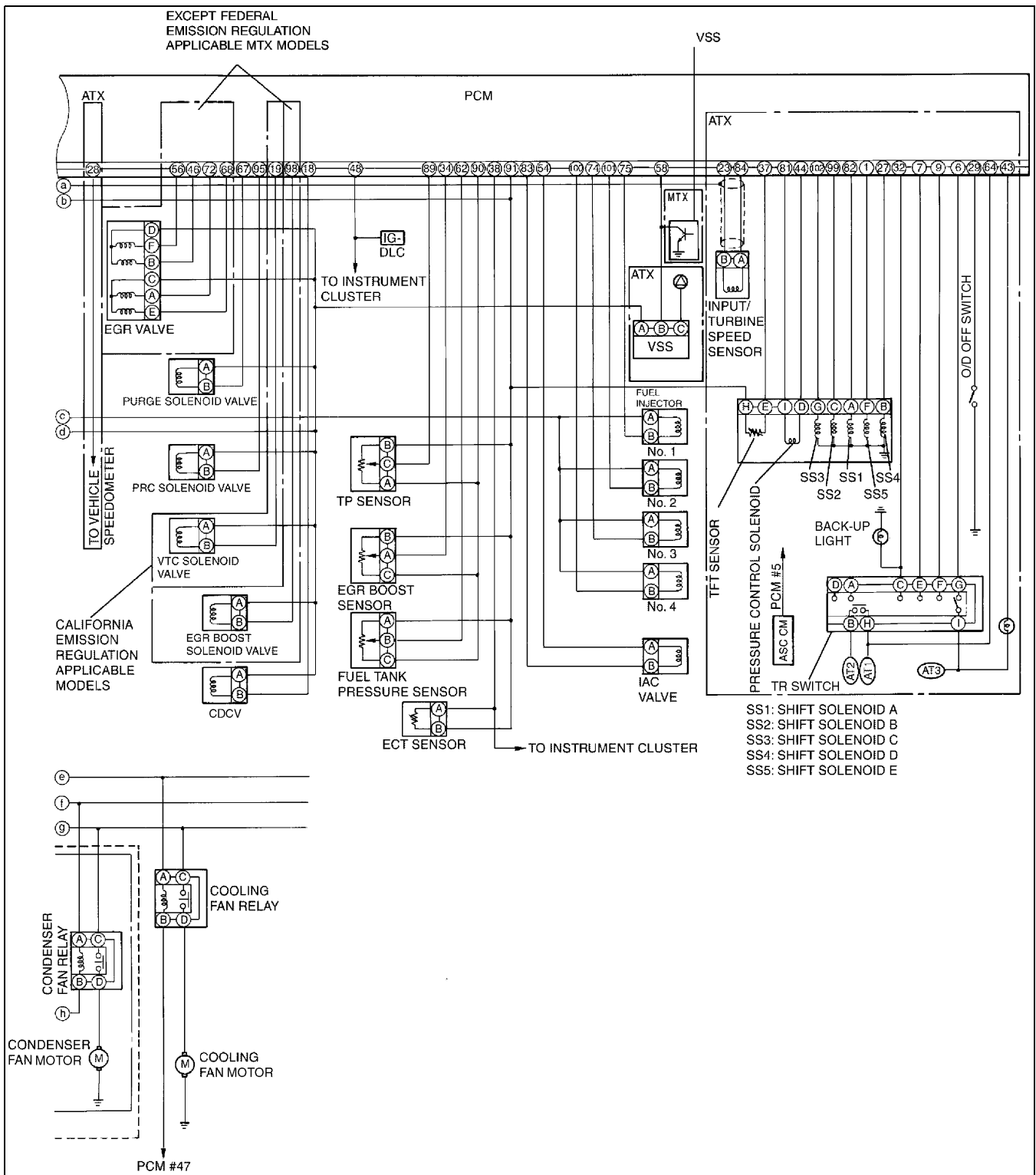

05-02

Y3U502WA1

# ON-BOARD DIAGNOSTIC

## FS Engine

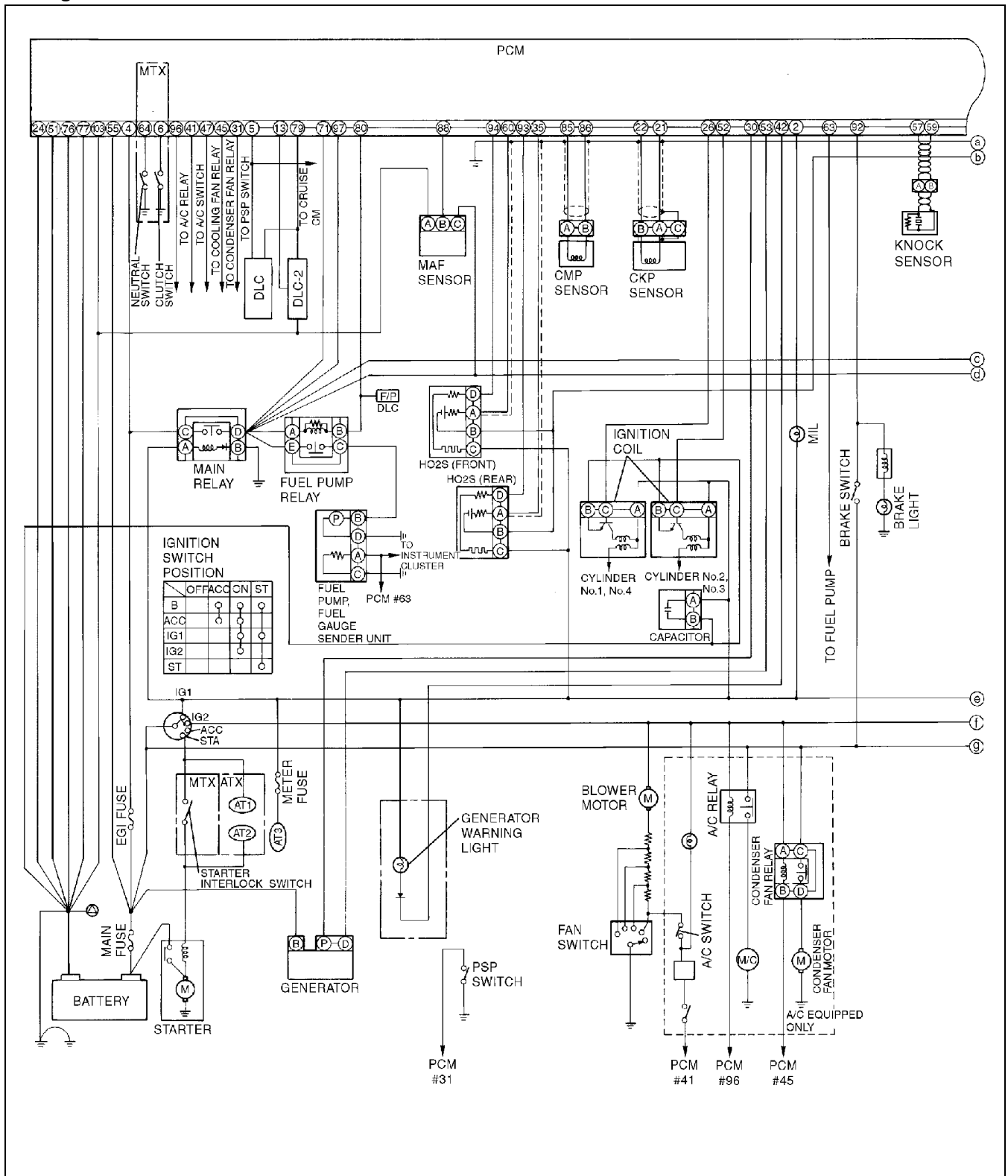

Z3U0140W103



# ON-BOARD DIAGNOSTIC

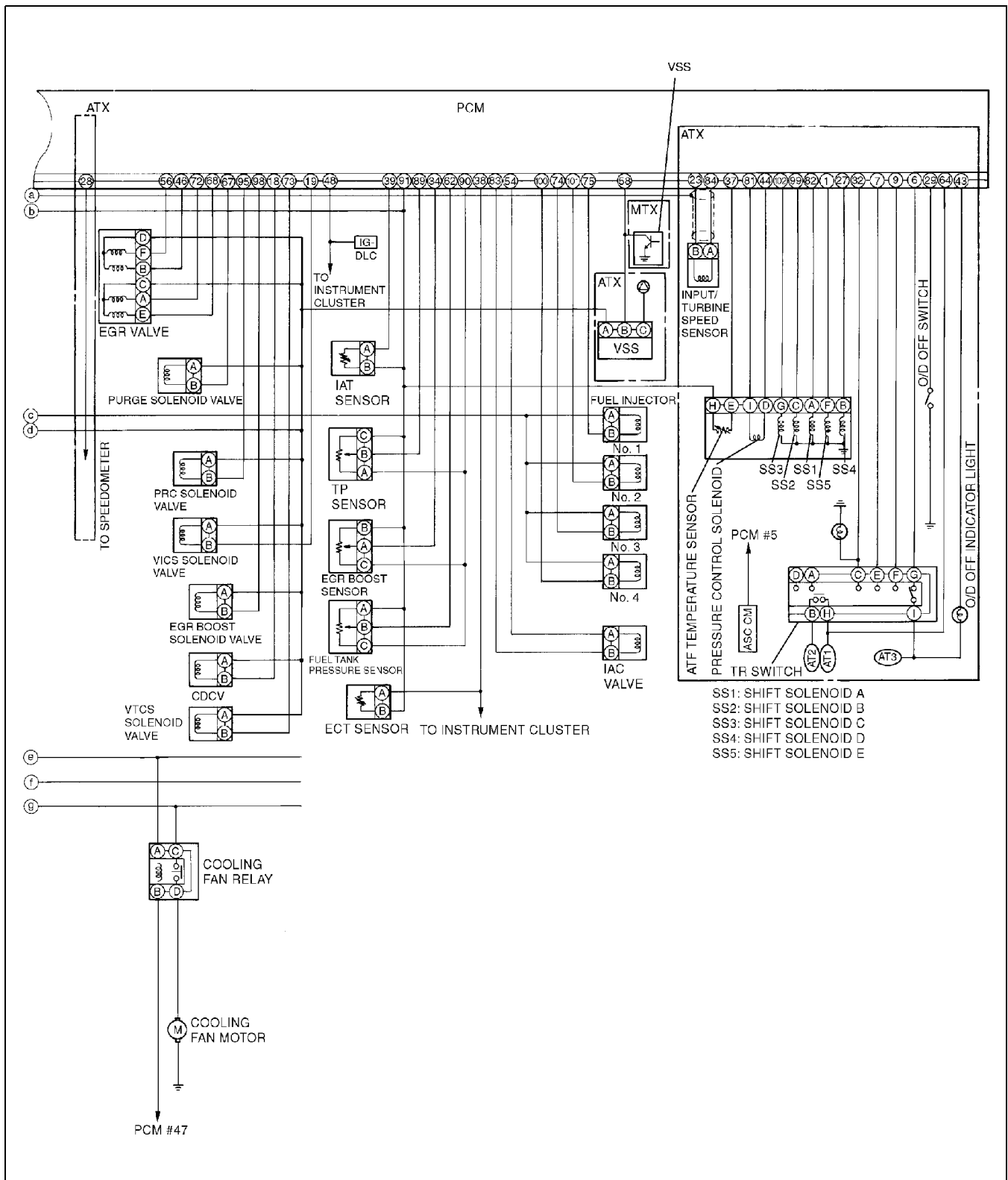

05-02

Z3U0140W104

# ON-BOARD DIAGNOSTIC

A3U050201030W02

## FOREWARD

- When the customer reports a vehicle malfunction, check the malfunction indicator lamp (MIL), O/D OFF indicator light flashing, and PCM memory for diagnostic trouble code (DTC), then diagnose the malfunction according to following flowchart.
  - If the DTC exists, diagnose the applicable DTC. (See 05-02-7 DTC TABLE.)
  - If the DTC does not exist, MIL does not illuminate, and O/D OFF indicator light flashes, diagnose the applicable symptom troubleshooting. (See 05-03-7 AUTOMATIC TRANSAXLE SYMPTOM TROUBLESHOOTING ITEM TABLE.)

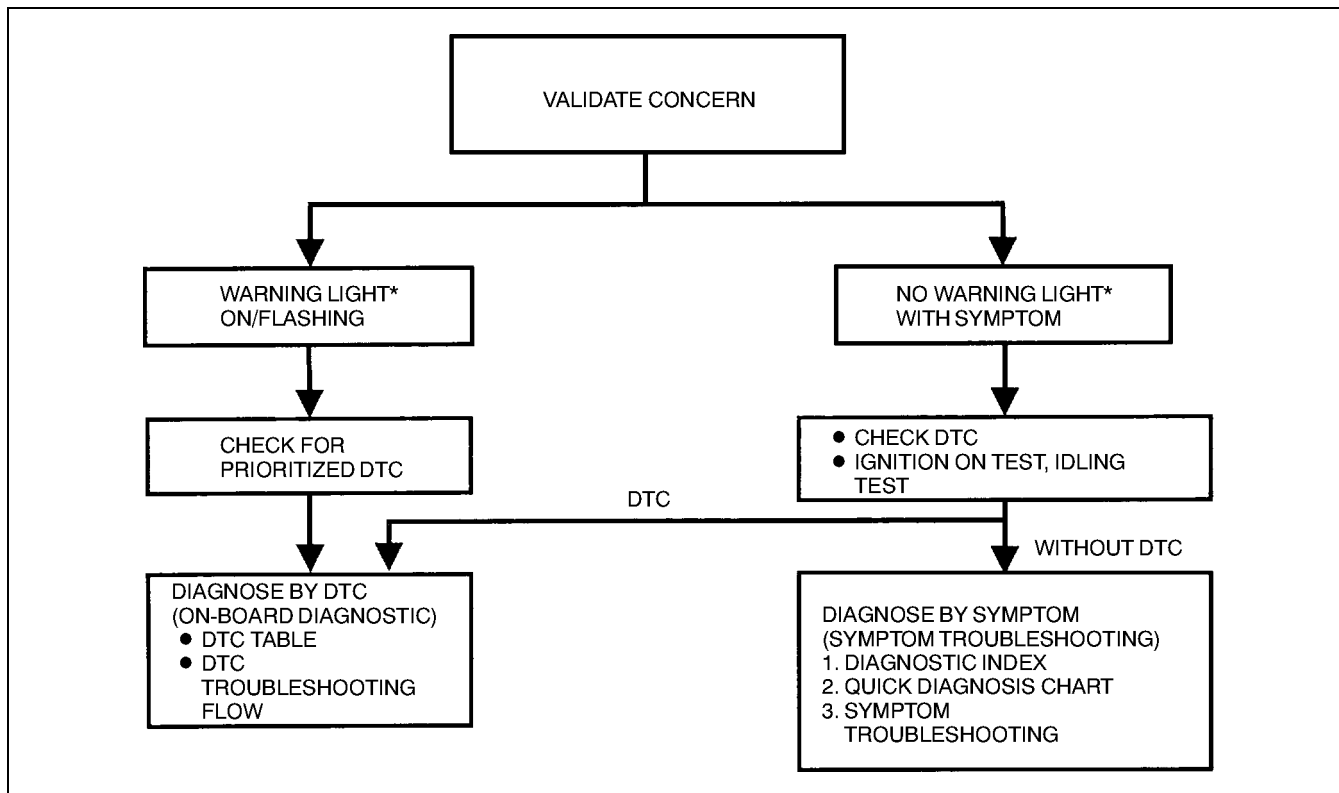

YMU102WBX

\*:Malfunction indicator lamp (MIL), O/D OFF indicator light

## AUTOMATIC TRANSAXLE ON-BOARD DIAGNOSTIC FUNCTION

A3U050201030W03

### DTC Reading Procedure

(See 01-02A-8 DTCs Retrieving Procedure.)

(See 01-02B-7 DTCs Retrieving Procedure.)

## AFTER REPAIR PROCEDURE

A3U050201030W04

### Caution

- After repairing a malfunction, perform this procedure to verify that the malfunction has been corrected.
- When this procedure is carried out, be sure to drive the vehicle at lawful speed and pay attention to the other vehicles.

1. Connect the WDS or equivalent to the DLC-2.
2. Turn the ignition key to ON (engine OFF).
3. Verify that DTCs are cleared from memory.
4. Decrease ATF temperature to **20 °C {68 °F} or below**.
5. Start the engine then wait **180 seconds or more**.
6. Warm up the engine and ATX.
  - Engine coolant temperature: **60 °C {140 °F} or above**.
  - Transaxle fluid temperature: **20 °C {68 °F} or above**.
7. Shift the selector lever between P position to 1 range while depressing brake pedal.
8. Drive the vehicle for **150 seconds or more** at a vehicle speed **between 25 and 59 km/h {15 and 36 mph}**, then **60 km/h {37 mph} or more** for **100 seconds or more**.
9. Drive the vehicle in D range and shift gears between 1st and 4th (TCC operation) gear.
10. Gradually slow down and stop the vehicle.

## 05-02-6

## ON-BOARD DIAGNOSTIC

11. Make sure that the repaired DTC does not recur.

### DTC TABLE

A3U050201030W05

DTC No.	Condition	MIL	O/D OFF indicator light flashes	DC	Monitor item	Memory function	Page
P0031	HO2S heater (front) circuit low						(See 01-02A-19 DTC P0031 [ZM]) (See 01-02B-19 DTC P0031 [FS])
P0032	HO2S heater (front) circuit high						(See 01-02A-20 DTC P0032 [ZM]) (See 01-02B-20 DTC P0032 [FS])
P0037	HO2S heater (rear) circuit low						(See 01-02A-22 DTC P0037 [ZM]) (See 01-02B-22 DTC P0037 [FS])
P0038	HO2S heater (rear) circuit high						(See 01-02A-23 DTC P0038 [ZM]) (See 01-02B-23 DTC P0038 [FS])
P0101	MAF circuit range/performance problem						(See 01-02B-25 DTC P0101 [FS])
P0102	MAF circuit low input						(See 01-02A-25 DTC P0102 [ZM]) (See 01-02B-27 DTC P0102 [FS])
P0103	MAF circuit high input						(See 01-02A-28 DTC P0103 [ZM]) (See 01-02B-29 DTC P0103 [FS])
P0106	BARO circuit performance problem						(See 01-02A-29 DTC P0106 [ZM]) (See 01-02B-30 DTC P0106 [FS])
P0107	BARO circuit low input						(See 01-02A-31 DTC P0107 [ZM]) (See 01-02B-31 DTC P0107 [FS])
P0108	BARO circuit high input						(See 01-02A-32 DTC P0108 [ZM]) (See 01-02B-34 DTC P0108 [FS])
P0111	IAT circuit performance problem						(See 01-02A-34 DTC P0111 [ZM]) (See 01-02B-35 DTC P0111 [FS])
P0112	IAT circuit low input						(See 01-02A-35 DTC P0112 [ZM]) (See 01-02B-36 DTC P0112 [FS])
P0113	IAT circuit high input						(See 01-02A-36 DTC P0113 [ZM]) (See 01-02B-38 DTC P0113 [FS])
P0117	ECT circuit low input						(See 01-02A-39 DTC P0117 [ZM]) (See 01-02B-40 DTC P0117 [FS])
P0118	ECT circuit high input						(See 01-02A-41 DTC P0118 [ZM]) (See 01-02B-42 DTC P0118 [FS])
P0121	TP circuit range/performance problem						(See 01-02B-43 DTC P0121 [FS])
P0122	TP circuit low input						(See 01-02A-42 DTC P0122 [ZM]) (See 01-02B-46 DTC P0122 [FS])
P0123	TP circuit high input						(See 01-02A-45 DTC P0123 [ZM]) (See 01-02B-47 DTC P0123 [FS])
P0125	Excessive time to enter closed loop fuel control						(See 01-02A-46 DTC P0125 [ZM]) (See 01-02B-49 DTC P0125 [FS])
P0126	Coolant thermostat stuck to open						(See 01-02B-50 DTC P0126, P0128 [FS])
P0128	Coolant thermostat stuck to open						(See 01-02B-50 DTC P0126, P0128 [FS])
P0130	HO2S (Front) circuit malfunction						(See 01-02A-48 DTC P0130 [ZM])
P0131	HO2S (Front) no inversion (Low voltage stuck)						(See 01-02B-52 DTC P0131 [FS])
P0132	HO2S (Front) no inversion (High voltage stuck)						(See 01-02B-55 DTC P0132 [FS])
P0133	HO2S (Front) circuit malfunction						(See 01-02B-57 DTC P0133 [FS])
P0134	HO2S (Front) circuit no activity detected						(See 01-02A-50 DTC P0134 [ZM]) (See 01-02B-61 DTC P0134 [FS])
P0138	HO2S (Rear) circuit high input						(See 01-02A-53 DTC P0138 [ZM]) (See 01-02B-63 DTC P0138 [FS])
P0140	HO2S (Rear) circuit no activity detected						(See 01-02A-55 DTC P0140 [ZM]) (See 01-02B-64 DTC P0140 [FS])
P0171	Fuel trim system too lean						(See 01-02A-57 DTC P0171 [ZM]) (See 01-02B-67 DTC P0171 [FS])
P0172	Fuel trim system too rich						(See 01-02A-60 DTC P0172 [ZM]) (See 01-02B-70 DTC P0172 [FS])
P0300	Random misfire detected						(See 01-02A-61 DTC P0300 [ZM]) (See 01-02B-71 DTC P0300 [FS])

05-02

## ON-BOARD DIAGNOSTIC

DTC No.	Condition	MIL	O/D OFF indicator light flashes	DC	Monitor item	Memory function	Page
P0301	Cylinder 1 misfire detected	(See 01-02A-65 DTC P0301, P0302, P0303, P0304 [ZM]) (See 01-02B-75 DTC P0301, P0302, P0303, P0304 [FS])					
P0302	Cylinder 2 misfire detected	(See 01-02A-65 DTC P0301, P0302, P0303, P0304 [ZM]) (See 01-02B-75 DTC P0301, P0302, P0303, P0304 [FS])					
P0303	Cylinder 3 misfire detected	(See 01-02A-65 DTC P0301, P0302, P0303, P0304 [ZM]) (See 01-02B-75 DTC P0301, P0302, P0303, P0304 [FS])					
P0304	Cylinder 4 misfire detected	(See 01-02A-65 DTC P0301, P0302, P0303, P0304 [ZM]) (See 01-02B-75 DTC P0301, P0302, P0303, P0304 [FS])					
P0325	Knock sensor circuit malfunction	(See 01-02B-77 DTC P0325 [FS])					
P0335	CKP sensor circuit malfunction	(See 01-02A-67 DTC P0335 [ZM]) (See 01-02B-79 DTC P0335 [FS])					
P0340	CMP sensor circuit malfunction	(See 01-02B-80 DTC P0340 [FS])					
P0401	EGR flow insufficient detected	(See 01-02A-69 DTC P0401 [ZM]) (See 01-02B-82 DTC P0401 [FS])					
P0402	EGR flow excessive detected	(See 01-02A-70 DTC P0402 [ZM]) (See 01-02B-83 DTC P0402 [FS])					
P0421	Warm-up catalyst system efficiency below threshold	(See 01-02A-71 DTC P0421 [ZM]) (See 01-02B-84 DTC P0421 [FS])					
P0442	Evaporative emission system leak detected (small leak)	(See 01-02A-72 DTC P0442 [ZM]) (See 01-02B-86 DTC P0442 [FS])					
P0443	Evaporative emission control system purge solenoid valve circuit malfunction	(See 01-02A-75 DTC P0443 [ZM]) (See 01-02B-89 DTC P0443 [FS])					
P0451	Fuel tank pressure sensor performance problem	(See 01-02A-77 DTC P0451 [ZM]) (See 01-02B-90 DTC P0451 [FS])					
P0452	Fuel tank pressure sensor low input	(See 01-02A-78 DTC P0452 [ZM]) (See 01-02B-93 DTC P0452 [FS])					
P0453	Fuel tank pressure sensor high input	(See 01-02A-80 DTC P0453 [ZM]) (See 01-02B-95 DTC P0453 [FS])					
P0455	Evaporative emission control system leak detected (blockage or large leak)	(See 01-02A-83 DTC P0455 [ZM]) (See 01-02B-97 DTC P0455 [FS])					
P0456	Evaporative emission control system leak detected (very small leak)	(See 01-02B-102 DTC P0456 [FS])					
P0461	Fuel gauge sender unit circuit range/performance	(See 01-02A-87 DTC P0461 [ZM]) (See 01-02B-104 DTC P0461 [FS])					
P0462	Fuel gauge sender unit circuit low input	(See 01-02A-88 DTC P0462 [ZM]) (See 01-02B-105 DTC P0462 [FS])					
P0463	Fuel gauge sender unit circuit high input	(See 01-02A-90 DTC P0463 [ZM]) (See 01-02B-107 DTC P0463 [FS])					
P0464	Fuel gauge sender unit circuit performance (slosh check)	(See 01-02A-91 DTC P0464 [ZM]) (See 01-02B-108 DTC P0464 [FS])					
P0480	Cooling fan relay malfunction	(See 01-02A-92 DTC P0480 [ZM]) (See 01-02B-109 DTC P0480 [FS])					
P0500	VSS circuit malfunction (MTX)	(See 01-02A-94 DTC P0500 [ZM]) (See 01-02B-111 DTC P0500 [FS])					
	VSS circuit malfunction (ATX)	ON	YES	2	CCM	×	(See 05-02-10 DTC P0500)
P0505	IAC valve circuit malfunction	(See 01-02B-113 DTC P0505 [FS])					
P0506	Idle control system RPM lower than expected	(See 01-02A-96 DTC P0506 [ZM]) (See 01-02B-115 DTC P0506 [FS])					
P0507	Idle control system RPM higher than expected	(See 01-02A-97 DTC P0507 [ZM]) (See 01-02B-117 DTC P0507 [FS])					
P0550	PSP switch circuit malfunction	(See 01-02A-99 DTC P0550 [ZM]) (See 01-02B-118 DTC P0550 [FS])					
P0660	VICS solenoid valve circuit malfunction	(See 01-02B-119 DTC P0660 [FS])					
P0703	Brake switch input malfunction	(See 01-02A-100 DTC P0703 [ZM]) (See 01-02B-122 DTC P0703 [FS])					
P0704	Clutch switch input circuit malfunction (MTX)	(See 01-02A-102 DTC P0704 [ZM]) (See 01-02B-123 DTC P0704 [FS])					

## ON-BOARD DIAGNOSTIC

DTC No.	Condition	MIL	O/D OFF indicator light flashes	DC	Monitor item	Memory function	Page
P0705	Neutral switch input circuit malfunction (MTX)	(See 01-02A-104 DTC P0705 [ZM]) (See 01-02B-125 DTC P0705 [FS])					
	Transaxle range (TR) switch circuit malfunction (Short circuit) (ATX)	ON	YES	1	CCM	×	(See 05-02-14 DTC P0705)
P0706	Transaxle range (TR) switch circuit malfunction (Open circuit)	ON	YES	2	CCM	×	(See 05-02-16 DTC P0706)
P0710	Transaxle fluid temperature (TFT) sensor circuit malfunction (short to ground/open circuit)	ON	YES	1	CCM	×	(See 05-02-18 DTC P0710)
P0711	Transaxle fluid temperature (TFT) sensor circuit malfunction (Stuck)	ON	NO	2	CCM	×	(See 05-02-21 DTC P0711)
P0715	Input/turbine speed sensor circuit malfunction	ON	YES	1	CCM	×	(See 05-02-22 DTC P0715)
P0731	Gear 1 incorrect (Incorrect Gear Ratio Detected)	OFF	YES	1	CCM	×	(See 05-02-24 DTC P0731)
P0732	Gear 2 incorrect (Incorrect Gear Ratio Detected)	OFF	YES	1	CCM	×	(See 05-02-26 DTC P0732)
P0733	Gear 3 incorrect (Incorrect Gear Ratio Detected)	OFF	YES	1	CCM	×	(See 05-02-28 DTC P0733)
P0734	Gear 4 incorrect (Incorrect Gear Ratio Detected)	OFF	YES	1	CCM	×	(See 05-02-30 DTC P0734)
P0741	Torque converter clutch (TCC) (stuck OFF)	OFF	YES	1	CCM	×	(See 05-02-32 DTC P0741)
P0742	Torque converter clutch (TCC) (stuck ON)	OFF	YES	1	CCM	×	(See 05-02-33 DTC P0742)
P0745	Pressure control solenoid malfunction	OFF	YES	1	CCM	×	(See 05-02-36 DTC P0745)
P0751	Shift solenoid A stuck OFF	ON	YES	2	CCM	×	(See 05-02-38 DTC P0751)
P0752	Shift solenoid A stuck ON	ON	YES	2	CCM	×	(See 05-02-40 DTC P0752)
P0753	Shift solenoid A malfunction (electrical)	ON	YES	1	CCM	×	(See 05-02-42 DTC P0753)
P0756	Shift solenoid B stuck OFF	ON	YES	2	CCM	×	(See 05-02-44 DTC P0756)
P0757	Shift solenoid B stuck ON	ON	YES	2	CCM	×	(See 05-02-46 DTC P0757)
P0758	Shift solenoid B malfunction (electrical)	ON	YES	1	CCM	×	(See 05-02-48 DTC P0758)
P0761	Shift solenoid C stuck OFF	ON	YES	2	CCM	×	(See 05-02-50 DTC P0761)
P0762	Shift solenoid C stuck ON	ON	YES	2	CCM	×	(See 05-02-52 DTC P0762)
P0763	Shift solenoid C malfunction (electrical)	ON	YES	1	CCM	×	(See 05-02-54 DTC P0763)
P0766	Shift solenoid D stuck OFF	ON	YES	2	CCM	×	(See 05-02-56 DTC P0766)
P0767	Shift solenoid D stuck ON	ON	YES	2	CCM	×	(See 05-02-58 DTC P0767.)
P0768	Shift solenoid D malfunction (electrical)	ON	YES	1	CCM	×	(See 05-02-60 DTC P0768)
P0771	Shift solenoid E stuck OFF	ON	YES	2	CCM	×	(See 05-02-62 DTC P0771)
P0772	Shift solenoid E stuck ON	ON	YES	2	CCM	×	(See 05-02-64 DTC P0772)
P0773	Shift solenoid E malfunction (electrical)	ON	YES	1	CCM	×	(See 05-02-66 DTC P0773)
P1102	MAF sensor inconsistent with TP sensor (Lower than expected)	(See 01-02A-106 DTC P1102 [ZM])					

05-02

## ON-BOARD DIAGNOSTIC

DTC No.	Condition	MIL	O/D OFF indicator light flashes	DC	Monitor item	Memory function	Page
P1103	Mass air flow inconsistent with engine speed (Greater than expected)						(See 01-02A-107 DTC P1103 [ZM])
P1122	Throttle position stuck closed (lower than expected)						(See 01-02A-108 DTC P1122 [ZM])
P1123	Throttle position stuck open (higher than expected)						(See 01-02A-110 DTC P1123 [ZM])
P1170	HO2S (front) no inversion						(See 01-02A-111 DTC P1170 [ZM])
P1250	PRC solenoid valve circuit malfunction						(See 01-02A-114 DTC P1250 [ZM]) (See 01-02B-127 DTC P1250 [FS])
P1345	CMP sensor circuit malfunction						(See 01-02A-116 DTC P1345 [ZM])
P1449	CDCV circuit malfunction						(See 01-02A-118 DTC P1449 [ZM]) (See 01-02B-129 DTC P1449 [FS])
P1450	Evaporative emission control system malfunction (excessive vacuum)						(See 01-02A-120 DTC P1450 [ZM]) (See 01-02B-131 DTC P1450 [FS])
P1487	EGR boost sensor solenoid valve circuit malfunction						(See 01-02A-121 DTC P1487 [ZM]) (See 01-02B-133 DTC P1487 [FS])
P1496	EGR valve stepping motor coil 1 open or short						(See 01-02A-123 DTC P1496 [ZM]) (See 01-02B-135 DTC P1496 [FS])
P1497	EGR valve stepping motor coil 2 open or short						(See 01-02A-125 DTC P1497 [ZM]) (See 01-02B-137 DTC P1497 [FS])
P1498	EGR valve stepping motor coil 3 open or short						(See 01-02A-127 DTC P1498 [ZM]) (See 01-02B-139 DTC P1498 [FS])
P1499	EGR valve stepping motor coil 4 open or short						(See 01-02A-129 DTC P1499 [ZM]) (See 01-02B-141 DTC P1499 [FS])
P1504	IAC valve circuit malfunction						(See 01-02A-131 DTC P1504 [ZM])
P1512	VTCS shutter valve close stuck						(See 01-02A-134 DTC P1512 [ZM]) (See 01-02B-143 DTC P1512 [FS])
P1562	PCM +BB voltage low						(See 01-02A-135 DTC P1562 [ZM]) (See 01-02B-144 DTC P1562 [FS])
P1569	VTCS solenoid valve circuit low input						(See 01-02A-137 DTC P1569 [ZM]) (See 01-02B-146 DTC P1569 [FS])
P1570	VTCS solenoid valve circuit high input						(See 01-02A-139 DTC P1570 [ZM]) (See 01-02B-148 DTC P1570 [FS])
P1631	Generator output voltage signal no electricity						(See 01-02A-141 DTC P1631 [ZM]) (See 01-02B-150 DTC P1631 [FS])
P1632	Battery voltage monitor signal circuit malfunction						(See 01-02A-143 DTC P1632 [ZM]) (See 01-02B-152 DTC P1632 [FS])
P1633	Battery overcharge						(See 01-02A-144 DTC P1633 [ZM]) (See 01-02B-153 DTC P1633 [FS])
P1634	Generator terminal B circuit open						(See 01-02A-145 DTC P1634 [ZM]) (See 01-02B-154 DTC P1634 [FS])

### DTC P0500

A3U050201030W06

DTC P0500	Vehicle speed sensor (VSS) malfunction
<b>DETECTION CONDITION</b>	<ul style="list-style-type: none"> <li>• Vehicle speed signal not input after following conditions are met and <b>4.5 seconds or more</b> have passed                             <ul style="list-style-type: none"> <li>— D, 2, or 1 range switch ON.</li> <li>— P and N position of TR switch OFF.</li> <li>— Engine coolant temperature <b>60 °C {140 °F} or above</b>.</li> <li>— Turbine speed <b>1,500 rpm or above</b>.</li> </ul> </li> </ul> <p><b>Diagnostic support note:</b></p> <ul style="list-style-type: none"> <li>• This is a continuous monitor (CCM).</li> <li>• MIL illuminates if PCM detects the above malfunction conditions during two consecutive drive cycles.</li> <li>• PENDING CODE is available.</li> <li>• FREEZE FRAME DATA is available.</li> <li>• O/D OFF indicator light flashes.</li> <li>• DTC is stored in the PCM memory.</li> </ul>

# ON-BOARD DIAGNOSTIC

<b>DTC P0500</b>	<b>Vehicle speed sensor (VSS) malfunction</b>
<b>POSSIBLE CAUSE</b>	<p><b>Without ABS:</b></p> <ul style="list-style-type: none"> <li>• VSS malfunction</li> <li>• Open circuit between VSS terminal B and PCM terminal 58</li> <li>• Short to ground between VSS terminal B and PCM terminal 58</li> <li>• Open circuit between VSS terminal A and fuse block connector (FB-01) terminal K</li> <li>• Open circuit between VSS terminal C and body ground</li> <li>• Damaged connectors between VSS and PCM</li> <li>• PCM malfunction</li> </ul> <p><b>With ABS:</b></p> <ul style="list-style-type: none"> <li>• ABS HU/CM malfunction</li> <li>• Open circuit between ABS HU/CM terminal J and PCM terminal 58</li> <li>• Short to ground between ABS HU/CM terminal J and PCM terminal 58</li> <li>• Damaged connectors between ABS HU/CM and PCM</li> <li>• PCM malfunction</li> </ul>

05-02

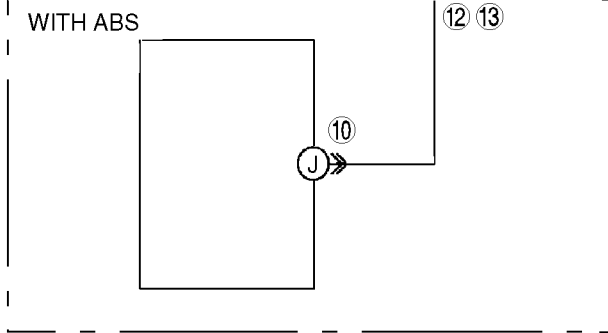
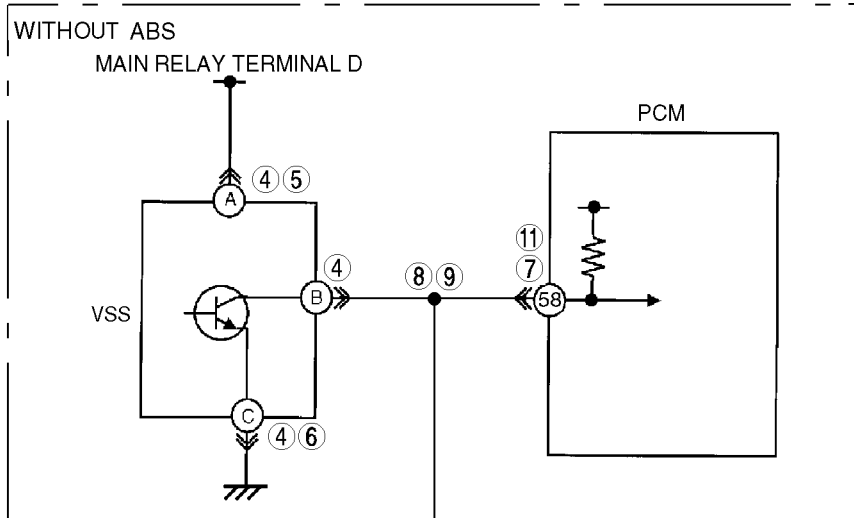

FUSE BLOCK CONNECTOR (FB-01)

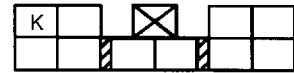

HARNESS SIDE CONNECTOR (VIEW FROM HARNESS SIDE)

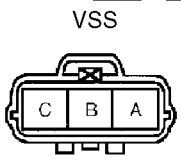

HARNESS SIDE CONNECTOR (VIEW FROM HARNESS SIDE)

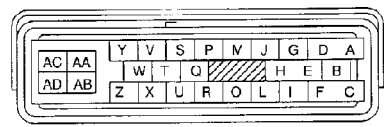

HARNESS SIDE CONNECTOR (VIEW FROM TERMINAL SIDE)

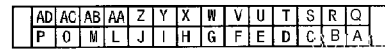

SST (49 G066 001) CONNECTOR (VIEW FROM TERMINAL SIDE)

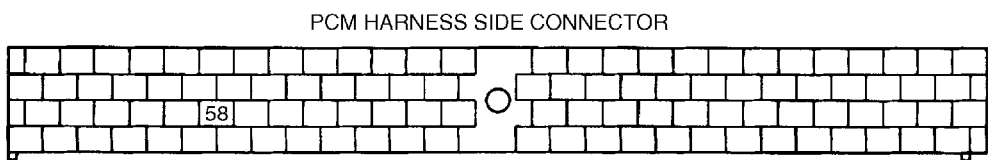

PCM HARNESS SIDE CONNECTOR (VIEW FROM TERMINAL SIDE)

## ON-BOARD DIAGNOSTIC

### Diagnostic procedure

STEP	INSPECTION	ACTION	
1	<b>VERIFY FREEZE FRAME DATA HAS BEEN RECORDED</b> <ul style="list-style-type: none"> <li>• Has FREEZE FRAME PID DATA been recorded?</li> </ul>	Yes	Go to next step.
		No	Record FREEZE FRAME PID DATA on repair order, then go to next step.
2	<b>VERIFY RELATED SERVICE INFORMATION AVAILABILITY</b> <ul style="list-style-type: none"> <li>• Check for related Service Bulletins availability.</li> <li>• Is any related repair Information available?</li> </ul>	Yes	Perform repair or diagnosis according to available repair Information. <ul style="list-style-type: none"> <li>• If vehicle is not repaired, go to next step.</li> </ul>
		No	Go to next step.
3	<b>VERIFY VEHICLE SPECIFICATION</b> <ul style="list-style-type: none"> <li>• Verify vehicle specification (With ABS, or without ABS).</li> <li>• Go to appropriate step.</li> </ul>		<ul style="list-style-type: none"> <li>• With ABS: Go to Step 10.</li> <li>• Without ABS: Go to next step</li> </ul>
4	<b>INSPECT VSS CONNECTOR FOR POOR CONNECTION</b> <ul style="list-style-type: none"> <li>• Turn ignition key to OFF.</li> <li>• Disconnect VSS connector.</li> <li>• Check for poor connection (damaged/pulled-out terminals, corrosion, etc.).</li> <li>• Is connection okay?</li> </ul>	Yes	Go to next step.
		No	Repair or replace pin or connector, then go to Step 14.
5	<b>INSPECT VSS POWER CIRCUIT FOR OPEN CIRCUIT</b> <ul style="list-style-type: none"> <li>• Verify that VSS connector is disconnected.</li> <li>• Turn ignition key to ON (Engine OFF).</li> <li>• Check voltage between VSS terminal A (harness-side) and ground</li> <li>• Is voltage reading <b>B+</b>?</li> </ul>	Yes	Go to next step.
		No	Repair or replace harness, then go to Step 14.
6	<b>INSPECT VSS GROUND CIRCUIT FOR OPEN</b> <ul style="list-style-type: none"> <li>• Turn ignition key to OFF.</li> <li>• Verify that VSS connector is disconnected.</li> <li>• Check for continuity between VSS terminal C (harness-side) and ground</li> <li>• Is there continuity?</li> </ul>	Yes	Go to next step.
		No	Repair or replace harness, then go to Step 14.
7	<b>INSPECT PCM CONNECTOR FOR POOR CONNECTION</b> <ul style="list-style-type: none"> <li>• Disconnect PCM connector.</li> <li>• Check for poor connection (damaged/pulled-out terminals, corrosion, etc.).</li> <li>• Is connection okay?</li> </ul>	Yes	Go to next step.
		No	Repair or replace pin or connector, then go to Step 14.
8	<b>INSPECT VEHICLE SPEED SIGNAL CIRCUIT FOR OPEN</b> <ul style="list-style-type: none"> <li>• Disconnect PCM connector and VSS connector.</li> <li>• Inspect for continuity between VSS terminal B and PCM terminal 58.</li> <li>• Is there continuity?</li> </ul>	Yes	Go to next step.
		No	Repair or replace harness, then go to Step 14.
9	<b>INSPECT VEHICLE SPEED SIGNAL CIRCUIT FOR SHORT TO GROUND</b> <ul style="list-style-type: none"> <li>• Verify that VSS connector and PCM connector are disconnected.</li> <li>• Inspect for continuity between PCM terminal 58 and body ground.</li> <li>• Is there continuity?</li> </ul>	Yes	Repair or replace harness, then go to Step 14.
		No	Repair VSS, then go to Step 14.
10	<b>INSPECT ABS HU/CM CONNECTOR FOR POOR CONNECTION</b> <ul style="list-style-type: none"> <li>• Turn ignition key to OFF.</li> <li>• Disconnect ABS HU/CM connector.</li> <li>• Check for poor connection (damaged/pulled-out terminals, corrosion, etc.).</li> <li>• Is connection okay?</li> </ul>	Yes	Go to next step.
		No	Repair or replace pin or connector, then go to Step 14.
11	<b>INSPECT PCM CONNECTOR FOR POOR CONNECTION</b> <ul style="list-style-type: none"> <li>• Disconnect PCM connector.</li> <li>• Check for poor connection (damaged/pulled-out terminals, corrosion, etc.).</li> <li>• Is connection okay?</li> </ul>	Yes	Go to next step.
		No	Repair or replace pin or connector, then go to Step 14.



## ON-BOARD DIAGNOSTIC

STEP	INSPECTION	ACTION	
12	<b>INSPECT VEHICLE SPEED SIGNAL CIRCUIT FOR OPEN</b> <ul style="list-style-type: none"> <li>• Disconnect PCM connector and ABS HU/CM connector.</li> <li>• Connect <b>SST</b> to ABS HU/CM vehicle harness side connector (Do not connect to ABS HU/CM).</li> <li>• Inspect for continuity between VSS terminal J and PCM terminal 58.</li> <li>• Is there continuity?</li> </ul>	Yes	Go to next step.
		No	Repair or replace harness, then go to Step 14.
13	<b>INSPECT VEHICLE SPEED SIGNAL CIRCUIT FOR SHORT TO GROUND</b> <ul style="list-style-type: none"> <li>• Verify that ABS HU/CM connector and PCM connector are disconnected.</li> <li>• Inspect for continuity between PCM terminal 58 and body ground.</li> <li>• Is there continuity?</li> </ul>	Yes	Repair or replace harness, then go to Step 14.
		No	Inspect ABS HU/CM, then go to Step 14.
14	<b>VERIFY TROUBLESHOOTING OF DTC P0500 COMPLETED</b> <ul style="list-style-type: none"> <li>• Make sure to reconnect all disconnected connectors.</li> <li>• Clear DTC from memory using WDS or equivalent.</li> <li>• Warm up engine.</li> <li>• Drive vehicle under following conditions for <b>4.5 seconds</b> or more while monitoring PIDs.                             <ul style="list-style-type: none"> <li>— Engine coolant temp: <b>60 °C {140 °F} or above</b></li> <li>— Drive in 1 range</li> <li>— Frequency of input/turbine speed sensor: <b>800 Hz</b></li> </ul> </li> <li>• Is pending code present?</li> </ul>	Yes	Replace PCM, then go to next step. (See 01-40A-7 PCM REMOVAL/INSTALLATION [ZM].) (See 01-40B-7 PCM REMOVAL/INSTALLATION [FS].)
		No	No concern is detected. Go to next step.
15	<b>VERIFY AFTER REPAIR PROCEDURE</b> <ul style="list-style-type: none"> <li>• Perform "After Repair Procedure". (See 05-02-6 AFTER REPAIR PROCEDURE.)</li> <li>• Are any DTCs present?</li> </ul>	Yes	Go to applicable DTC inspection.
		No	Troubleshooting completed.

05-02

# ON-BOARD DIAGNOSTIC

**DTC P0705**

A3U050201030W07

<b>DTC P0705</b>	<b>Transaxle range (TR) switch circuit malfunction (short circuit)</b>
<b>DETECTION CONDITION</b>	<ul style="list-style-type: none"> <li>• When all conditions below satisfied and <b>100 seconds or more</b> have passed:                             <ul style="list-style-type: none"> <li>— Any of D, 2 or 1 range of TR switch ON.</li> <li>— Engine speed <b>530 rpm or above</b>.</li> <li>— P/N position or R position of TR switch ON.</li> </ul> </li> </ul> <p><b>Diagnostic support note:</b></p> <ul style="list-style-type: none"> <li>• This is a continuous monitor (CCM).</li> <li>• MIL illuminates if PCM detects the above malfunction conditions during first drive cycle.</li> <li>• PENDING CODE is not available.</li> <li>• FREEZE FRAME DATA is available.</li> <li>• O/D OFF indicator light flashes.</li> <li>• DTC is stored in the PCM memory.</li> </ul>
<b>POSSIBLE CAUSE</b>	<ul style="list-style-type: none"> <li>• TR switch malfunction</li> <li>• Short to power between TR switch terminal C and PCM terminal 32</li> <li>• Short to power between TR switch terminal G and PCM terminal 6</li> <li>• Short to power between TR switch terminal F and PCM terminal 9</li> <li>• Short to power between TR switch terminal E and PCM terminal 7</li> <li>• Damaged connector between TR switch and PCM</li> <li>• PCM malfunction</li> </ul>

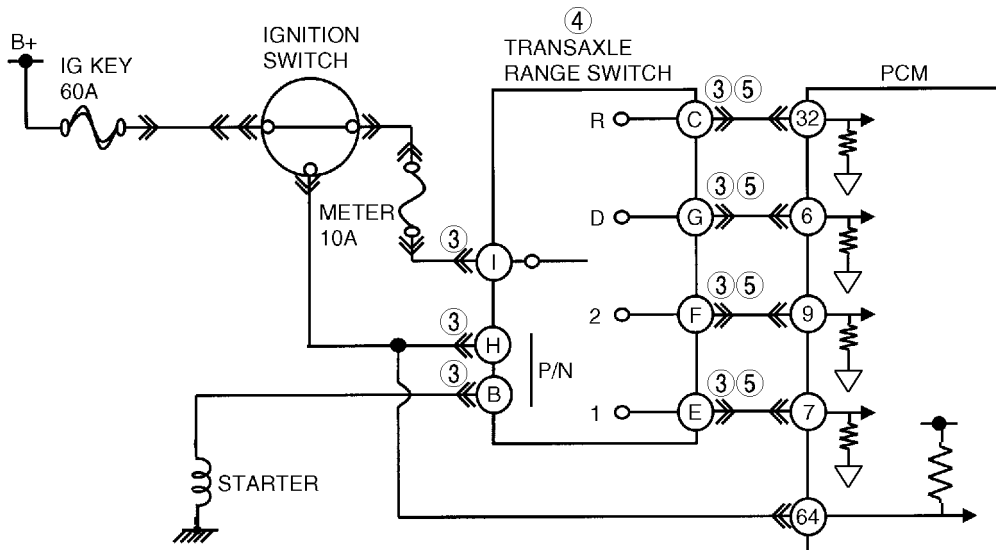

TRANSAXLE RANGE SWITCH



HARNESS SIDE CONNECTOR  
(VIEW FROM HARNESS SIDE)

PCM HARNESS SIDE CONNECTOR

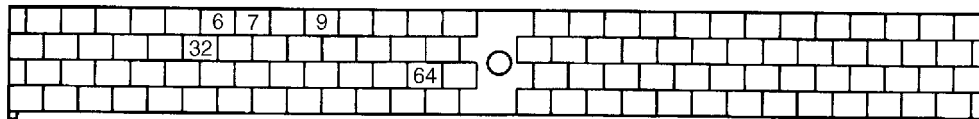

(VIEW FROM TERMINAL SIDE)

## ON-BOARD DIAGNOSTIC

### Diagnostic procedure

STEP	INSPECTION	ACTION	
1	<b>VERIFY FREEZE FRAME DATA HAS BEEN RECORDED</b> <ul style="list-style-type: none"> <li>• Has FREEZE FRAME PID DATA been recorded?</li> </ul>	Yes	Go to next step.
		No	Record FREEZE FRAME PID DATA on repair order, then go to next step.
2	<b>VERIFY RELATED REPAIR INFORMATION AVAILABILITY</b> <ul style="list-style-type: none"> <li>• Check for related Service Bulletins availability.</li> <li>• Is any related repair information available?</li> </ul>	Yes	Perform repair or diagnosis according to available repair information. <ul style="list-style-type: none"> <li>• If vehicle is not repaired, go to next step.</li> </ul>
		No	Go to next step.
3	<b>INSPECT TR SWITCH CONNECTOR</b> <ul style="list-style-type: none"> <li>• Turn ignition key OFF.</li> <li>• Disconnect TR switch connector.</li> <li>• Inspect for bent terminals of pins using mirror.</li> <li>• Are TR switch terminals okay?</li> </ul>	Yes	Go to next step.
		No	Repair terminals or replace TR switch, then go to Step 6. (See 05-17-20 TRANSAXLE RANGE (TR) SWITCH REMOVAL/INSTALLATION.)
4	<b>INSPECT TR SWITCH CONTINUITY</b> <ul style="list-style-type: none"> <li>• Turn ignition key to OFF.</li> <li>• Disconnect TR switch connector.</li> <li>• Is there continuity between TR switch terminals (part-side)?</li> </ul> (See 05-17-20 TRANSAXLE RANGE (TR) SWITCH INSPECTION.)	Yes	Go to next step.
		No	Replace TR switch, then go to Step 6. (See 05-17-20 TRANSAXLE RANGE (TR) SWITCH REMOVAL/INSTALLATION.)
5	<b>INSPECT TR SWITCH CIRCUIT FOR SHORT TO POWER</b> <ul style="list-style-type: none"> <li>• Turn ignition key to ON (engine OFF).</li> <li>• Measure voltage at TR switch terminals C, E, F and G (harness-side).</li> <li>• Is there <b>0 V</b> at TR switch harness side connector?</li> </ul>	Yes	Go to next step.
		No	Repair or replace wiring, then go to next step.
6	<b>VERIFY TROUBLESHOOTING OF DTC P0705 COMPLETED</b> <ul style="list-style-type: none"> <li>• Make sure to reconnect all disconnected connectors.</li> <li>• Clear DTC from memory using WDS or equivalent.</li> <li>• Run engine at <b>530 rpm or above</b>.</li> <li>• Drive vehicle in each range (D, 2, and 1) at engine speed <b>530 rpm or above</b> (VSS PID) for <b>100 seconds or more</b>.</li> <li>• Are any DTCs present?</li> </ul>	Yes	Replace PCM, then go to next step. (See 01-40A-7 PCM REMOVAL/INSTALLATION [ZM].) (See 01-40B-7 PCM REMOVAL/INSTALLATION [FS].)
		No	No concern is detected. Go to next step.
7	<b>VERIFY AFTER REPAIR PROCEDURE</b> <ul style="list-style-type: none"> <li>• Perform "After Repair Procedure". (See 05-02-6 AFTER REPAIR PROCEDURE.)</li> <li>• Are any DTCs present?</li> </ul>	Yes	Go to applicable DTC inspection.
		No	Troubleshooting completed.

05-02

# ON-BOARD DIAGNOSTIC

**DTC P0706**

A3U050201030W08

<b>DTC P0706</b>	<b>Transaxle range (TR) switch circuit malfunction (open circuit)</b>
<b>DETECTION CONDITION</b>	<ul style="list-style-type: none"> <li>• When all conditions below satisfied and <b>100 seconds or more</b> have passed.                             <ul style="list-style-type: none"> <li>— D, 2, 1 range and R range switch not input.</li> <li>— Engine speed <b>530 rpm or above</b>.</li> <li>— Vehicle speed <b>20 km/h {12 mph} or above</b>.</li> </ul> </li> <li>• <b>Diagnostic support note:</b> <ul style="list-style-type: none"> <li>• This is a continuous monitor (CCM).</li> <li>• MIL illuminates if PCM detects the above malfunction conditions during two consecutive drive cycles.</li> <li>• PENDING CODE is available.</li> <li>• FREEZE FRAME DATA is available.</li> <li>• O/D OFF indicator light flashes.</li> <li>• DTC is stored in the PCM memory.</li> </ul> </li> </ul>
<b>POSSIBLE CAUSE</b>	<ul style="list-style-type: none"> <li>• Charging system malfunction</li> <li>• TR switch malfunction</li> <li>• TR switch misadjustment</li> <li>• Open circuit between TR switch terminal G and PCM terminal 6</li> <li>• Open circuit between TR switch terminal F and PCM terminal 9</li> <li>• Open circuit between TR switch terminal E and PCM terminal 7</li> <li>• Open circuit between TR switch terminal I and dash harness (JB-04) terminals</li> <li>• Damaged connectors between TR switch and PCM</li> <li>• PCM malfunction</li> </ul>

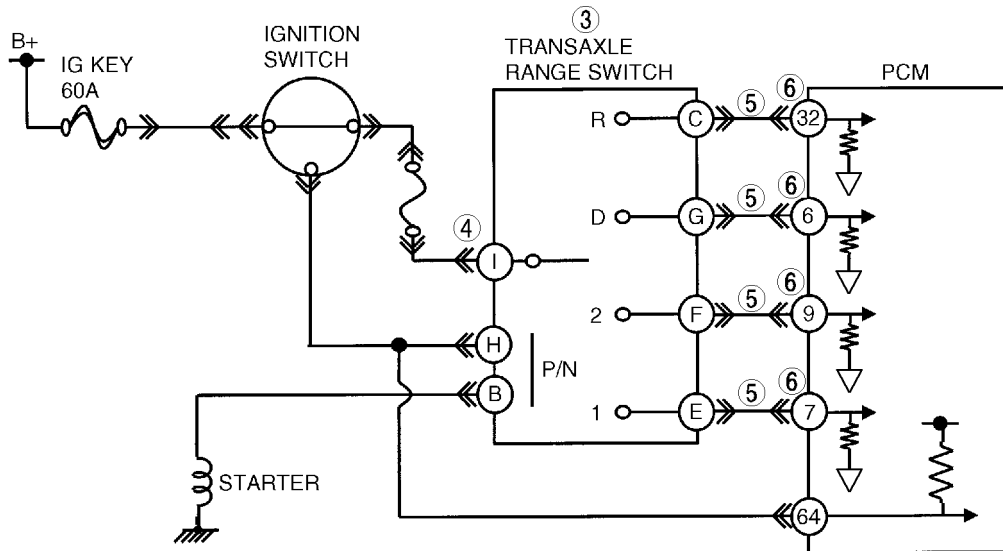

TRANSAXLE RANGE SWITCH

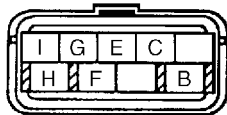

HARNESS SIDE CONNECTOR  
(VIEW FROM HARNESS SIDE)

PCM HARNESS SIDE CONNECTOR

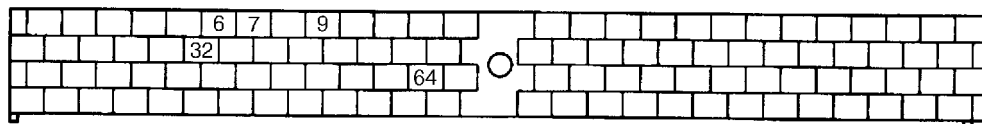

(VIEW FROM TERMINAL SIDE)

## ON-BOARD DIAGNOSTIC

### Diagnostic procedure

STEP	INSPECTION	ACTION
1	<b>VERIFY FREEZE FRAME DATA HAS BEEN RECORDED</b> <ul style="list-style-type: none"> <li>Has FREEZE FRAME PID DATA been recorded?</li> </ul>	Yes Go to next step.
		No Record FREEZE FRAME PID DATA on repair order, then go to next step.
2	<b>VERIFY RELATED REPAIR INFORMATION AVAILABILITY</b> <ul style="list-style-type: none"> <li>Check for related Service Bulletins availability.</li> <li>Is any related repair information available?</li> </ul>	Yes Perform repair or diagnosis according to available repair information. <ul style="list-style-type: none"> <li>If vehicle is not repaired, go to next step.</li> </ul>
		No Go to next step.
3	<b>INSPECT TR SWITCH FOR OPEN</b> <ul style="list-style-type: none"> <li>Turn ignition key to OFF.</li> <li>Disconnect TR switch connector.</li> <li>Inspect for continuity between TR switch terminals (part-side).                             <ul style="list-style-type: none"> <li>D range: I and G</li> <li>2 range: I and F</li> <li>1 range: I and E</li> <li>R range: I and C</li> </ul> </li> <li>Is there continuity between TR switch terminals (part-side)?</li> </ul> (See 05-17-20 TRANSAXLE RANGE (TR) SWITCH INSPECTION.)	Yes Go to next step.
		No Replace TR switch, then go to Step 7. (See 05-17-20 TRANSAXLE RANGE (TR) SWITCH REMOVAL/INSTALLATION.)
4	<b>INSPECT TR SWITCH POWER CIRCUIT FOR OPEN</b> <ul style="list-style-type: none"> <li>Turn ignition key to ON.</li> <li>Inspect voltage at TR switch terminal I (harness-side).</li> <li>Is there <b>B+</b> at TR switch terminal I (harness-side)?</li> </ul>	Yes Go to next step.
		No Inspect main fuse. <ul style="list-style-type: none"> <li>If okay, repair or replace wiring, then go to Step 7.</li> </ul>
5	<b>INSPECT PCM CONNECTOR FOR POOR CONNECTION</b> <ul style="list-style-type: none"> <li>Turn ignition key to OFF.</li> <li>Check for poor connection (damaged/pulled-out terminals, corrosion, etc.).</li> <li>Is connection okay?</li> </ul>	Yes Go to next step.
		No Repair or replace connector and/or terminals, then go to Step 7.
6	<b>INSPECT TR SWITCH SIGNAL CIRCUIT FOR OPEN</b> <ul style="list-style-type: none"> <li>Inspect for continuity between TR switch terminals (harness-side) and PCM terminals (harness-side).                             <ul style="list-style-type: none"> <li>D range: G to 6</li> <li>2 range: F to 9</li> <li>1 range: E to 7</li> <li>R range: C to 32</li> </ul> </li> <li>Is there continuity?</li> </ul>	Yes Go to next step.
		No Repair or replace harness, then go to next step.
7	<b>VERIFY TROUBLESHOOTING OF DTC P0706 COMPLETED</b> <ul style="list-style-type: none"> <li>Make sure to reconnect all disconnected connectors.</li> <li>Clear DTC from memory using WDS or equivalent.</li> <li>Drive vehicle in each range (D, 2, 1, and R) for <b>100 seconds or more</b> under following conditions.                             <ul style="list-style-type: none"> <li>Engine speed (RPM PID) <b>530 rpm or above</b></li> <li>Vehicle speed (VSS PID) <b>20 km/h {12 mph} or above</b></li> </ul> </li> <li>Is pending code present?</li> </ul>	Yes Replace PCM, then go to next step. (See 01-40A-7 PCM REMOVAL/INSTALLATION [ZM].) (See 01-40B-7 PCM REMOVAL/INSTALLATION [FS].)
		No No concern is detected. Go to next step.
8	<b>VERIFY AFTER REPAIR PROCEDURE</b> <ul style="list-style-type: none"> <li>Perform "After Repair Procedure". (See 05-02-6 AFTER REPAIR PROCEDURE.)</li> <li>Are any DTCs present?</li> </ul>	Yes Go to applicable DTC inspection.
		No Troubleshooting completed.

05-02

# ON-BOARD DIAGNOSTIC

**DTC P0710**

A3U050201030W09

<b>DTC P0710</b>	<b>Transaxle fluid temperature (TFT) sensor circuit malfunction (short to ground/open circuit)</b>
<b>DETECTION CONDITION</b>	<ul style="list-style-type: none"> <li>If PCM detects either of following conditions for <b>150 seconds or more</b>, PCM determines that TFT sensor circuit has a malfunction.                             <ul style="list-style-type: none"> <li>— TFT sensor voltage is <b>0.06 V or below</b> and vehicle speed <b>20 km/h {12 mph} or above</b>.</li> <li>— TFT sensor voltage is <b>4.67 V or above</b> and vehicle speed <b>20 km/h {12 mph} or above</b>.</li> </ul> </li> </ul> <p><b>Diagnostic support note:</b></p> <ul style="list-style-type: none"> <li>This is a continuous monitor (CCM).</li> <li>MIL illuminates if PCM detects the above malfunction conditions during first drive cycle.</li> <li>PENDING CODE is not available.</li> <li>FREEZE FRAME DATA is available.</li> <li>O/D OFF indicator light flashes.</li> <li>DTC is stored in the PCM memory.</li> </ul>
<b>POSSIBLE CAUSE</b>	<ul style="list-style-type: none"> <li>TFT sensor malfunction</li> <li>Open circuit between TFT sensor terminal A and ATX connector terminal E</li> <li>Short to ground between TFT sensor terminal A and ATX connector terminal E</li> <li>Open circuit between TFT sensor terminal B and ATX connector terminal H</li> <li>Short to ground between TFT sensor terminal B and ATX connector terminal H</li> <li>Open circuit between ATX connector terminal E and PCM terminal 37</li> <li>Short to ground between ATX connector terminal E and PCM terminal 37</li> <li>Open circuit between ATX connector terminal H and PCM terminal 91</li> <li>Short to ground between ATX connector terminal H and PCM terminal 91</li> <li>Damaged connectors between TFT sensor and PCM</li> <li>PCM malfunction</li> </ul>

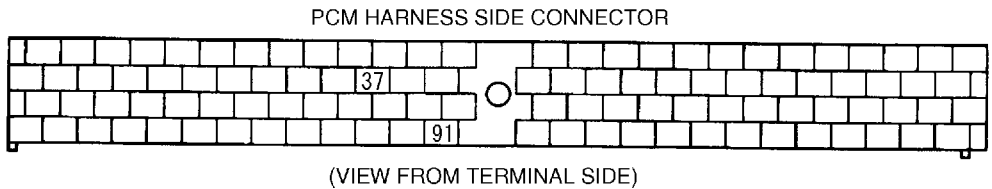
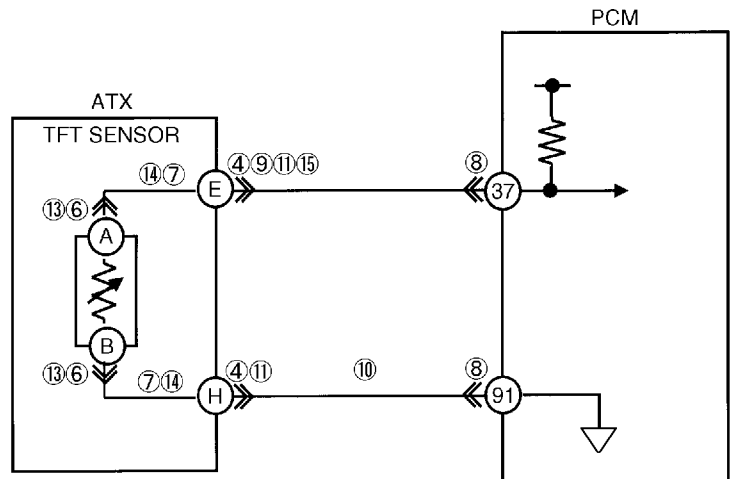

## ON-BOARD DIAGNOSTIC

### Diagnostic procedure

STEP	INSPECTION	ACTION
1	<b>VERIFY FREEZE FRAME DATA HAS BEEN RECORDED</b> <ul style="list-style-type: none"> <li>Has FREEZE FRAME PID DATA been recorded?</li> </ul>	Yes Go to next step.
		No Record FREEZE FRAME PID DATA on repair order, then go to next step.
2	<b>VERIFY RELATED REPAIR INFORMATION AVAILABILITY</b> <ul style="list-style-type: none"> <li>Check for related Service Bulletins availability.</li> <li>Is any related repair information available?</li> </ul>	Yes Perform repair or diagnosis according to available repair information. <ul style="list-style-type: none"> <li>If vehicle is not repaired, go to next step.</li> </ul>
		No Go to next step.
3	<b>VERIFY CURRENT INPUT SIGNAL STATUS</b> <ul style="list-style-type: none"> <li>Turn ignition key to OFF.</li> <li>Connect breakout box to PCM.</li> <li>Turn ignition key to ON (engine OFF).</li> <li>Measure the voltage at PCM terminal 37.</li> <li>Are voltage readings <b>within 0.06—4.67 V</b>?</li> </ul>	Yes Go to intermittent concern troubleshooting procedure. (See 01–03A–4 INTERMITTENT CONCERN TROUBLESHOOTING [ZM].) (See 01–03B–4 INTERMITTENT CONCERN TROUBLESHOOTING [FS].)
		No Voltage <b>0.06 V or below</b> : go to Step 11. Voltage <b>4.67 V or above</b> : go to next step.
4	<b>INSPECT ATX CONNECTOR FOR POOR CONNECTION</b> <ul style="list-style-type: none"> <li>Turn ignition key to OFF.</li> <li>Inspect ATX connector connection.</li> <li>Disconnect ATX connector.</li> <li>Check for poor connection (damaged/pulled-out terminals, corrosion etc.).</li> <li>Is connection okay?</li> </ul>	Yes Go to next step.
		No Repair or replace connector and/or terminal, then go to Step 16.
5	<b>INSPECT TFT SENSOR CIRCUIT</b> <ul style="list-style-type: none"> <li>Turn ignition key to ON (engine OFF).</li> <li>Measure the voltage at PCM terminal 37 when connect between ATX connector terminals E and H (vehicle harness-side) using jumper wire.</li> <li>Verify that voltage changes to <b>0.06 V or below</b>.</li> <li>Does voltage change?</li> </ul>	Yes Go to next step.
		No Go to Step 8.
6	<b>INSPECT TFT SENSOR CONNECTOR FOR POOR CONNECTION</b> <ul style="list-style-type: none"> <li>Turn ignition key to OFF.</li> <li>Remove valve body cover.</li> <li>Disconnect TFT sensor connector.</li> <li>Check for poor connection (damaged/pulled-out terminals, corrosion, etc.).</li> <li>Is connection okay?</li> </ul>	Yes Go to next step.
		No Repair or replace connector and/or terminal or replace TFT sensor, then go to Step 16. (See 05–17–25 TRANSAXLE FLUID TEMPERATURE (TFT) SENSOR REMOVAL/INSTALLATION.)
7	<b>INSPECT TFT SENSOR CIRCUIT FOR OPEN</b> <ul style="list-style-type: none"> <li>Check for continuity between TFT sensor terminals (harness-side) and ATX connector terminals (transaxle case side).                             <ul style="list-style-type: none"> <li>— ATX connector terminal E and TFT sensor terminal A</li> <li>— ATX connector terminal H and TFT sensor terminal B</li> </ul> </li> <li>Is there continuity?</li> </ul>	Yes Replace TFT sensor, then go to Step 16. (See 05–17–25 TRANSAXLE FLUID TEMPERATURE (TFT) SENSOR REMOVAL/INSTALLATION.)
		No Repair or replace harness, then go to Step 16.
8	<b>INSPECT PCM CONNECTOR FOR POOR CONNECTION</b> <ul style="list-style-type: none"> <li>Turn ignition key to OFF.</li> <li>Disconnect PCM connector.</li> <li>Check for poor connection (damaged/pulled-out terminals, corrosion, etc.).</li> <li>Is connection okay?</li> </ul>	Yes Go to next step.
		No Repair or replace connector and/or terminal, then go to Step 16.
9	<b>INSPECT HARNESS FOR OPEN CIRCUIT</b> <ul style="list-style-type: none"> <li>Disconnect ATX connector.</li> <li>Connect the PCM connector.</li> <li>Turn ignition key to ON (engine OFF).</li> <li>Inspect voltage at ATX connector terminal E (vehicle harness-side).</li> <li>Is voltage <b>5 V</b>?</li> </ul>	Yes Go to next step.
		No Repair or replace harness, then go to Step 16.

05–02

## ON-BOARD DIAGNOSTIC

STEP	INSPECTION	ACTION	
10	<b>INSPECT ATX CONNECTOR CIRCUIT FOR OPEN</b> <ul style="list-style-type: none"> <li>• Turn ignition key to OFF.</li> <li>• Inspect continuity between ATX connector terminal H (vehicle harness-side) and body ground.</li> <li>• Is there continuity?</li> </ul>	Yes	Go to Step 16.
		No	Repair or replace harness, then go to Step 16.
11	<b>INSPECT TERMINAL CONDITION</b> <ul style="list-style-type: none"> <li>• Turn ignition key to OFF.</li> <li>• Disconnect ATX connector.</li> <li>• Inspect for bent terminals.</li> <li>• Are the terminals bent?</li> </ul>	Yes	Repair or replace terminals, then go to Step 16. <ul style="list-style-type: none"> <li>• If terminals cannot be repaired, replace harness, then go to Step 16.</li> </ul>
		No	Go to next step.
12	<b>INSPECT TFT SENSOR CIRCUIT</b> <ul style="list-style-type: none"> <li>• Turn ignition key to ON (engine OFF).</li> <li>• Verify if voltage changes to <b>4.67 V or above</b> at PCM terminal 37 when ATX connector disconnected.</li> <li>• Does voltage change?</li> </ul>	Yes	Go to next step.
		No	Go to Step 15.
13	<b>INSPECT TFT SENSOR TERMINALS CONDITION</b> <ul style="list-style-type: none"> <li>• Turn ignition key to OFF.</li> <li>• Disconnect TFT sensor connector.</li> <li>• Inspect for bent TFT sensor terminals.</li> <li>• Are the terminals bent?</li> </ul>	Yes	Repair terminals or replace TFT sensor, then go to Step 16. (See 05-17-25 TRANSAXLE FLUID TEMPERATURE (TFT) SENSOR REMOVAL/INSTALLATION.)
		No	Go to next step.
14	<b>INSPECT TFT SENSOR CIRCUIT FOR SHORT TO GROUND</b> <ul style="list-style-type: none"> <li>• Inspect for continuity between TFT sensor terminals (harness-side) and body ground. <ul style="list-style-type: none"> <li>— A and body ground</li> <li>— B and body ground</li> </ul> </li> <li>• Is there continuity?</li> </ul>	Yes	Repair or replace harness, then go to Step 16.
		No	Replace TFT sensor, then go to Step 16. (See 05-17-25 TRANSAXLE FLUID TEMPERATURE (TFT) SENSOR REMOVAL/INSTALLATION.)
15	<b>INSPECT ATX CONNECTOR CIRCUIT FOR SHORT TO GROUND</b> <ul style="list-style-type: none"> <li>• Turn ignition key to OFF.</li> <li>• Inspect for continuity between ATX connector terminal E (vehicle harness-side) and body ground.</li> <li>• Is there continuity?</li> </ul>	Yes	Repair or replace harness, then go to next step.
		No	Go to next step.
16	<b>VERIFY TROUBLESHOOTING OF DTC P0710 COMPLETED</b> <ul style="list-style-type: none"> <li>• Make sure to reconnect all disconnected connectors.</li> <li>• Clear DTC from memory using WDS or equivalent.</li> <li>• Drive vehicle under following condition for <b>150 seconds or more</b>. <ul style="list-style-type: none"> <li>— Vehicle speed (VSS PID) <b>20 km/h {12 mph} or above</b>.</li> </ul> </li> <li>• Is same DTC present?</li> </ul>	Yes	Replace PCM, then go to next step. (See 01-40A-7 PCM REMOVAL/INSTALLATION [ZM].) (See 01-40B-7 PCM REMOVAL/INSTALLATION [FS].)
		No	Go to next step.
17	<b>VERIFY AFTER REPAIR PROCEDURE</b> <ul style="list-style-type: none"> <li>• Perform "After Repair Procedure". (See 05-02-6 AFTER REPAIR PROCEDURE.)</li> <li>• Are any DTCs present?</li> </ul>	Yes	Go to applicable DTC inspection.
		No	Troubleshooting completed.



# ON-BOARD DIAGNOSTIC

DTC P0711

A3U050201030W10

<b>DTC P0711</b>	<b>Transaxle fluid temperature (TFT) sensor circuit malfunction (stuck)</b>
<b>DETECTION CONDITION</b>	<ul style="list-style-type: none"> <li>• When all conditions below are satisfied.                             <ul style="list-style-type: none"> <li>— When <b>180 seconds</b> have passed after engine is started, vehicle is driven for <b>150 seconds or more</b> at vehicle speed <b>between 25 – 59 km/h {15 – 36 mph}</b>, then <b>60 km/h {37 mph} or more</b> for <b>100 seconds or more</b>.</li> <li>— P0710 not output.</li> <li>— Variation in ATF voltage <b>below 0.06 V</b>.</li> </ul> </li> </ul> <p><b>Diagnostic support note:</b></p> <ul style="list-style-type: none"> <li>• This is a continuous monitor (CCM).</li> <li>• MIL illuminates if PCM detects the above malfunction conditions during two consecutive drive cycles.</li> <li>• PENDING CODE is available.</li> <li>• FREEZE FRAME DATA is available.</li> <li>• O/D OFF indicator light does not flash.</li> <li>• DTC is stored in the PCM memory.</li> </ul>
<b>POSSIBLE CAUSE</b>	<ul style="list-style-type: none"> <li>• TFT sensor malfunction</li> <li>• Connector corrosion</li> <li>• PCM malfunction</li> </ul>

05-02

## Diagnostic procedure

STEP	INSPECTION		ACTION
1	<b>VERIFY FREEZE FRAME DATA HAS BEEN RECORDED</b> <ul style="list-style-type: none"> <li>• Has FREEZE FRAME PID DATA been recorded?</li> </ul>	Yes	Go to next step.
		No	Record FREEZE FRAME PID DATA on repair order, then go to next step.
2	<b>VERIFY RELATED REPAIR INFORMATION AVAILABILITY</b> <ul style="list-style-type: none"> <li>• Check for related Service Bulletins availability.</li> <li>• Is any related repair information available?</li> </ul>	Yes	Perform repair or diagnosis according to available repair information. <ul style="list-style-type: none"> <li>• If vehicle is not repaired, go to next step.</li> </ul>
		No	Go to next step.
3	<b>INSPECT TFT SENSOR VOLTAGE</b> <ul style="list-style-type: none"> <li>• Turn ignition key to OFF.</li> <li>• Connect breakout box to PCM.</li> <li>• Turn ignition key to ON (engine OFF).</li> <li>• Measure the voltage at PCM terminal 37.</li> <li>• Record terminal 37 voltage.</li> <li>• Start engine.</li> <li>• Drive vehicle at <b>60 km/h {37 mph} or above</b> for <b>430 seconds or more</b>.</li> <li>• Record terminal 37 voltage again.</li> <li>• Is variation in voltage <b>0.06V or above</b>?</li> </ul>	Yes	Go to Step 5.
		No	Go to next step.
4	<b>INSPECT TERMINAL CONDITION</b> <ul style="list-style-type: none"> <li>• Turn ignition key to OFF.</li> <li>• Disconnect ATX connector.</li> <li>• Inspect terminals for corrosion.</li> <li>• Are terminals okay?</li> </ul>	Yes	Go to next step.
		No	Repair or replace terminals, then go to next step.
5	<b>VERIFY TROUBLESHOOTING OF DTC P0711 COMPLETED</b> <ul style="list-style-type: none"> <li>• Make sure to reconnect all disconnected connectors.</li> <li>• Clear DTC from memory using WDS or equivalent.</li> <li>• Decrease ATF temperature to <b>20 °C {68 °F} or below</b>.</li> <li>• Start engine and wait for <b>180 seconds or more</b>.</li> <li>• Drive vehicle at a vehicle speed <b>between 25 – 59 km/h {15 – 36 mph}</b> for <b>150 seconds or more</b>.</li> <li>• Drive vehicle at vehicle speed <b>60 km/h {37 mph} or above</b> for <b>100 seconds or more</b>.</li> <li>• Is pending code present?</li> </ul>	Yes	Replace PCM, then go to next step. (See 01-40A-7 PCM REMOVAL/INSTALLATION [ZM].) (See 01-40B-7 PCM REMOVAL/INSTALLATION [FS].)
		No	Go to next step.
6	<b>VERIFY AFTER REPAIR PROCEDURE</b> <ul style="list-style-type: none"> <li>• Perform "After Repair Procedure". (See 05-02-6 AFTER REPAIR PROCEDURE.)</li> <li>• Are any DTCs present?</li> </ul>	Yes	Go to applicable DTC inspection.
		No	Troubleshooting completed.

# ON-BOARD DIAGNOSTIC

**DTC P0715**

A3U050201030W11

<b>DTC P0715</b>	<b>Input/turbine speed sensor circuit malfunction</b>
<b>DETECTION CONDITION</b>	<ul style="list-style-type: none"> <li>• When all conditions below satisfied and <b>0.7 second or more</b> have passed.                             <ul style="list-style-type: none"> <li>— D, 2 or 1 range of TR switch input.</li> <li>— Driving vehicle with vehicle speed <b>40 km/h {25 mph} or above.</b></li> <li>— Input/turbine speed sensor signal not input.</li> </ul> </li> </ul> <p><b>Diagnostic support note:</b></p> <ul style="list-style-type: none"> <li>• This is a continuous monitor (CCM).</li> <li>• MIL illuminates if PCM detects the above malfunction conditions during first drive cycle.</li> <li>• PENDING CODE is not available.</li> <li>• FREEZE FRAME DATA is available.</li> <li>• O/D OFF indicator light flashes.</li> <li>• DTC is stored in the PCM memory.</li> </ul>
<b>POSSIBLE CAUSE</b>	<ul style="list-style-type: none"> <li>• Input/turbine speed sensor malfunction</li> <li>• Short to ground between input/turbine speed sensor terminal A and PCM terminal 84</li> <li>• Short to ground between input/turbine speed sensor terminal B and PCM terminal 23</li> <li>• Open circuit between input/turbine speed sensor terminal A and PCM terminal 84</li> <li>• Open circuit between input/turbine speed sensor terminal B and PCM terminal 23</li> <li>• Damaged connectors between input/turbine speed sensor and PCM</li> <li>• PCM malfunction</li> </ul>

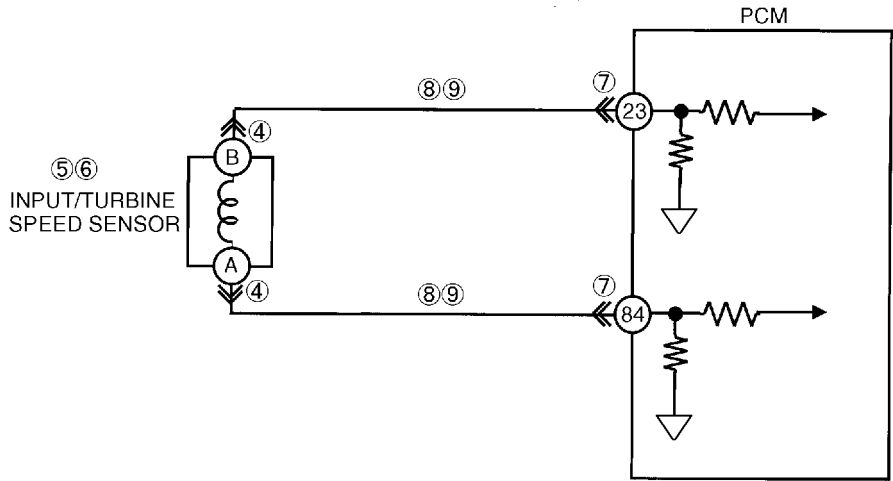

INPUT/TURBINE SPEED SENSOR



HARNESS SIDE CONNECTOR  
(VIEW FROM HARNESS SIDE)

PCM HARNESS SIDE CONNECTOR

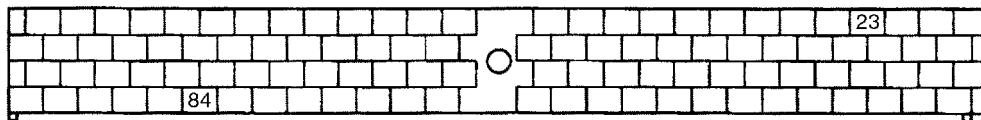

(VIEW FROM TERMINAL SIDE)

## ON-BOARD DIAGNOSTIC

### Diagnostic procedure

STEP	INSPECTION	ACTION	
1	<b>VERIFY FREEZE FRAME DATA HAS BEEN RECORDED</b> <ul style="list-style-type: none"> <li>• Has FREEZE FRAME PID DATA been recorded?</li> </ul>	Yes	Go to next step.
		No	Record FREEZE FRAME PID DATA on repair order, then go to next step.
2	<b>VERIFY RELATED REPAIR INFORMATION AVAILABILITY</b> <ul style="list-style-type: none"> <li>• Check for related Service Bulletins availability.</li> <li>• Is any related repair information available?</li> </ul>	Yes	Perform repair or diagnosis according to available repair information. <ul style="list-style-type: none"> <li>• If vehicle is not repaired, go to next step.</li> </ul>
		No	Go to next step.
3	<b>VERIFY CURRENT INPUT SIGNAL STATUS</b> <ul style="list-style-type: none"> <li>• Turn ignition key to OFF.</li> <li>• Start engine.</li> <li>• Measure frequency of input/turbine speed sensor using a oscilloscope.                             <ul style="list-style-type: none"> <li>— IG ON: <b>0 Hz</b></li> <li>— Idle: <b>Within 320—374 Hz</b> (P, N position)</li> </ul> </li> <li>• Are frequency of input/turbine speed sensor readings within specifications?</li> </ul>	Yes	Go to intermittent concern troubleshooting procedure. (See 01–03A–4 INTERMITTENT CONCERN TROUBLESHOOTING [ZM].) (See 01–03B–4 INTERMITTENT CONCERN TROUBLESHOOTING [FS].)
		No	Go to next step.
4	<b>INSPECT INPUT/TURBINE SPEED SENSOR CONNECTOR FOR POOR CONNECTION</b> <ul style="list-style-type: none"> <li>• Turn ignition key to OFF.</li> <li>• Disconnect input/turbine speed sensor connector.</li> <li>• Check for poor connection (damaged/pulled-out terminals, corrosion, etc.).</li> <li>• Is connection okay?</li> </ul>	Yes	Go to next step.
		No	Repair or replace connector and/or terminals, then go to Step 10.
5	<b>INSPECT INPUT/TURBINE SPEED SENSOR RESISTANCE</b> <ul style="list-style-type: none"> <li>• Measure resistance between input/turbine speed sensor terminals (part-side).</li> <li>• Is resistance <b>within 250—600 ohms</b> between input/turbine speed sensor terminals (part-side)? (See 05–17–26 INPUT/TURBINE SPEED SENSOR INSPECTION.)</li> </ul>	Yes	Go to next step.
		No	Replace input/turbine speed sensor, then go to Step 10. (See 05–17–26 INPUT/TURBINE SPEED SENSOR REMOVAL/INSTALLATION.)
6	<b>INSPECT INPUT/TURBINE SPEED SENSOR</b> <ul style="list-style-type: none"> <li>• Remove input/turbine speed sensor.</li> <li>• Is there iron powder stuck on input/turbine speed sensor? (See 05–17–26 INPUT/TURBINE SPEED SENSOR REMOVAL/INSTALLATION.)</li> </ul>	Yes	Clean input/turbine speed sensor, then go to Step 10.
		No	Go to next step.
7	<b>INSPECT PCM CONNECTOR FOR POOR CONNECTION</b> <ul style="list-style-type: none"> <li>• Disconnect PCM connector.</li> <li>• Check for poor connection (damaged/pulled-out terminals, corrosion, etc.).</li> <li>• Is connection okay?</li> </ul>	Yes	Go to next step.
		No	Repair or replace connector and/or terminals, then go to Step 10.
8	<b>INSPECT INPUT/TURBINE SPEED SENSOR CIRCUIT FOR OPEN</b> <ul style="list-style-type: none"> <li>• Inspect input/turbine speed sensor terminals (harness-side) and PCM terminals (harness-side).                             <ul style="list-style-type: none"> <li>— A and 84</li> <li>— B and 23</li> </ul> </li> <li>• Is there continuity?</li> </ul>	Yes	Go to next step.
		No	Repair or replace harness, then go to Step 10.
9	<b>INSPECT INPUT/TURBINE SPEED SENSOR CIRCUIT FOR SHORT TO GROUND</b> <ul style="list-style-type: none"> <li>• Inspect input/turbine speed sensor terminal (harness-side) and body ground.                             <ul style="list-style-type: none"> <li>— A and body ground</li> <li>— B and body ground</li> </ul> </li> <li>• Is there continuity?</li> </ul>	Yes	Repair or replace harness, then go to next step.
		No	Go to next step.

05–02

## ON-BOARD DIAGNOSTIC

STEP	INSPECTION	ACTION
10	<b>VERIFY TROUBLESHOOTING OF DTC P0715 COMPLETED</b> <ul style="list-style-type: none"> <li>Make sure to reconnect all disconnected connectors.</li> <li>Clear DTC from memory using WDS or equivalent.</li> <li>Drive vehicle with vehicle speed <b>40 km/h {25 mph} or above</b> for <b>0.7 second or more</b>.</li> <li>Is same DTC present?</li> </ul>	Yes Replace PCM, then go to next step. (See 01-40A-7 PCM REMOVAL/INSTALLATION [ZM].) (See 01-40B-7 PCM REMOVAL/INSTALLATION [FS].)
		No Go to next step.
11	<b>VERIFY AFTER REPAIR PROCEDURE</b> <ul style="list-style-type: none"> <li>Perform "After Repair Procedure". (See 05-02-6 AFTER REPAIR PROCEDURE.)</li> <li>Are any DTCs present?</li> </ul>	Yes Go to applicable DTC inspection.
		No Troubleshooting completed.

### DTC P0731

A3U050201030W12

DTC P0731	Gear 1 incorrect (Incorrect Gear Ratio Detected)
<b>DETECTION CONDITION</b>	<ul style="list-style-type: none"> <li>PCM monitors revolution ratio of forward clutch drum revolution to differential gear case revolution when the following monitoring conditions are met. If revolution ratio is <b>below 2.157</b>, PCM determines that there is malfunction.</li> </ul> <p><b>Monitoring condition:</b></p> <ul style="list-style-type: none"> <li>ATF temperature <b>20 °C {68 °F} or above</b>.</li> <li>Driving in 1GR in D range.</li> <li>Engine run.</li> <li>Turbine speed <b>within 225—4,988 rpm</b>.</li> <li>Throttle opening angle <b>3.13% or above</b> (FS engine)</li> <li>Throttle opening angle <b>3.91% or above</b> (ZM engine)</li> <li>Differential gear case (output) revolution speed <b>35 rpm or above</b>.</li> <li>Any of the following not generated: DTC P0500, P0705, P0706, P0710, P0715, P0751, P0752, P0753, P0756, P0757, P0758, P0761, P0762, P0763, P0766, P0767, P0768, P0771, P0772, P0773.</li> </ul> <p><b>Diagnostic support note:</b></p> <ul style="list-style-type: none"> <li>This is a continuous monitor (CCM).</li> <li>MIL does not illuminate.</li> <li>O/D OFF indicator light flashes if PCM detects the above malfunction condition during first drive cycle.</li> <li>FREEZE FRAME DATA is not available.</li> <li>Pending code is not available.</li> <li>DTC stored in the PCM memory.</li> </ul>
<b>POSSIBLE CAUSE</b>	<ul style="list-style-type: none"> <li>ATF level low</li> <li>Deteriorated ATF</li> <li>Shift solenoid A stuck</li> <li>Pressure control solenoid stuck</li> <li>Line pressure low</li> <li>One-way clutch slipping</li> <li>Forward clutch slipping</li> <li>Control valve stuck</li> <li>Oil pump</li> <li>PCM malfunction</li> </ul>

### Diagnostic procedure

STEP	INSPECTION	ACTION
1	<b>VERIFY RELATED REPAIR INFORMATION AVAILABILITY</b> <ul style="list-style-type: none"> <li>Check for related Service Bulletins availability.</li> <li>Is any related repair information available?</li> </ul>	Yes Perform repair or diagnosis according to available repair information.
		No Go to next step.
2	<b>CHECK ATF CONDITION</b> <ul style="list-style-type: none"> <li>Check ATF condition. (See 05-17-17 AUTOMATIC TRANSAXLE FLUID (ATF) INSPECTION.)</li> <li>Is it okay?</li> </ul>	Yes Go to next step.
		No Replace transaxle, then go to Step 8.
3	<b>CHECK ATF LEVEL</b> <ul style="list-style-type: none"> <li>Start engine.</li> <li>Warm up ATX.</li> <li>Is ATF level within specification? (See 05-17-17 AUTOMATIC TRANSAXLE FLUID (ATF) INSPECTION.)</li> </ul>	Yes Go to next step.
		No Adjust ATF level, then go to Step 8.

## ON-BOARD DIAGNOSTIC

STEP	INSPECTION	ACTION	
4	<b>INSPECT SHIFT SOLENOID VALVE A</b> <ul style="list-style-type: none"> <li>Perform inspection of operation. (See 05-17-28 SOLENOID VALVES INSPECTION.)</li> <li>Verify the click sound of shift solenoid A when applying B+ to transaxle connector terminal A.</li> <li>Was click heard from solenoids?</li> </ul>	Yes	Go to next step.
		No	Replace solenoid that you could not hear click sound, then go to Step 8. (See 05-17-30 SOLENOID VALVES REMOVAL/INSTALLATION.)
5	<b>INSPECT LINE PRESSURE</b> <ul style="list-style-type: none"> <li>Start engine.</li> <li>Measure line pressures.</li> </ul> <b>Specification</b> <b>FS engine</b> <b>Idle: 330—470 kPa {3.4—4.7 kgf/cm<sup>2</sup>, 49—66 psi}</b> <b>Stall: 1,160—1,320 kPa {11.9—13.4 kgf/cm<sup>2</sup>, 170—190 psi}</b> <b>ZM engine</b> <b>Idle: 330—470 kPa {3.4—4.7 kgf/cm<sup>2</sup>, 49—66 psi}</b> <b>Stall: 1,200—1,360 kPa {12.3—13.8 kgf/cm<sup>2</sup>, 175—196 psi}</b> <ul style="list-style-type: none"> <li>Is line pressure within specification? (See 05-17-12 Line Pressure Test.)</li> </ul>	Yes	Go to next step.
		No	All ranges: Replace oil pump, then go to Step 8. Any ranges: Replace control valve body, then go to Step 8. (See 05-17-36 CONTROL VALVE BODY REMOVAL/INSTALLATION.)
6	<b>INSPECT STALL SPEED</b> <ul style="list-style-type: none"> <li>Measure stall speed in D range. (See 05-17-13 Stall Test.)</li> </ul> <b>Specification</b> <b>FS engine: 2,200—2,500 rpm</b> <b>ZM engine: 2,300—2,600 rpm</b> <ul style="list-style-type: none"> <li>Is stall speed within specification?</li> </ul>	Yes	Go to next step.
		No	Replace automatic transaxle, then go to Step 8. (See 05-17-31 AUTOMATIC TRANSAXLE (ATX) REMOVAL/INSTALLATION.)
7	<b>INSPECT FREQUENCY OF INPUT/TURBINE SPEED SENSOR WHEN DRIVING VEHICLE</b> <ul style="list-style-type: none"> <li>Turn ignition key to OFF.</li> <li>Connect WDS or equivalent.</li> <li>Start engine.</li> <li>Measure frequency of input/turbine speed sensor while driving vehicle under the following conditions: <ul style="list-style-type: none"> <li>Vehicle speed (VSS PID): <b>20 km/h {12 mph}</b></li> <li>Drive in D range, 1st gear</li> <li>Throttle opening angle (TP PID): <b>about 25%</b></li> </ul> </li> <li>Was frequency of input/turbine speed sensor at <b>approx. 1,087 Hz</b>?</li> </ul>	Yes	Go to next step.
		No	Replace control valve body, then go to next step. (See 05-17-36 CONTROL VALVE BODY REMOVAL/INSTALLATION.)
8	<b>VERIFY REPAIR OF DTC P0731</b> <ul style="list-style-type: none"> <li>Make sure to reconnect all disconnected connectors.</li> <li>Clear DTC using WDS or equivalent.</li> <li>Start engine.</li> <li>Warm up transaxle.</li> <li>Drive vehicle under the following conditions for <b>more than 15 seconds</b>. <ul style="list-style-type: none"> <li>ATF temperature: <b>20 °C {68 °F} or above</b></li> <li>Drive in D range, 1st gear</li> <li>Throttle opening angle (TP PID): <b>3.13% or above</b> (FS engine)</li> <li>Throttle opening angle (TP PID): <b>3.91% or above</b> (ZM engine)</li> <li>Vehicle speed (VSS PID): <b>4 km/h {3 mph} or above</b></li> </ul> </li> <li>Are any DTCs present?</li> </ul>	Yes	Replace PCM, then go to next step.
		No	Go to next step.
9	<b>VERIFY AFTER REPAIR PROCEDURE</b> <ul style="list-style-type: none"> <li>Perform "After Repair Procedure". (See 05-02-6 AFTER REPAIR PROCEDURE.)</li> <li>Are any DTCs present?</li> </ul>	Yes	Go to applicable DTC inspection.
		No	Troubleshooting completed.

05-02

# ON-BOARD DIAGNOSTIC

DTC P0732

A3U050201030W13

DTC P0732	Gear 2 incorrect (Incorrect Gear Ratio Detected)
<b>DETECTION CONDITION</b>	<ul style="list-style-type: none"> <li>PCM monitors revolution ratio of forward clutch drum revolution to differential gear case revolution when the following monitoring conditions are met. If revolution ratio is <b>below 1.249 or above 2.157</b>, PCM determines that there is malfunction.</li> </ul> <p><b>Monitoring condition:</b></p> <ul style="list-style-type: none"> <li>— ATF temperature <b>20 °C {68 °F} or above.</b></li> <li>— Driving in 2 GR in D range.</li> <li>— Engine run.</li> <li>— Turbine speed <b>within 225—4,988 rpm.</b></li> <li>— Differential gear case (output) revolution speed <b>35 rpm or above.</b></li> <li>— Any of the following not generated: DTC P0500, P0705, P0706, P0710, P0715, P0751, P0752, P0753, P0756, P0757, P0758, P0761, P0762, P0763, P0766, P0767, P0768, P0771, P0772, P0773.</li> </ul> <p><b>Diagnostic support note:</b></p> <ul style="list-style-type: none"> <li>This is a continuous monitor (CCM).</li> <li>MIL does not illuminate.</li> <li>O/D OFF indicator light flashes if PCM detects the above malfunction condition during first drive cycle.</li> <li>FREEZE FRAME DATA is not available.</li> <li>Pending code is not available.</li> <li>DTC stored in the PCM memory.</li> </ul>
<b>POSSIBLE CAUSE</b>	<ul style="list-style-type: none"> <li>ATF level low</li> <li>Deteriorated ATF</li> <li>Shift solenoids A, B or C stuck</li> <li>Pressure control solenoid stuck</li> <li>Line pressure low</li> <li>2-4 brake band slipping</li> <li>Forward clutch slipping</li> <li>Control valve stuck</li> <li>Oil pump</li> <li>PCM malfunction</li> </ul>

## Diagnostic procedure

STEP	INSPECTION		ACTION
1	<b>VERIFY RELATED REPAIR INFORMATION AVAILABILITY</b> <ul style="list-style-type: none"> <li>Check for related Service Bulletins availability.</li> <li>Is any related repair information available?</li> </ul>	Yes	Perform repair or diagnosis according to available repair information.
		No	Go to next step.
2	<b>CHECK ATF CONDITION</b> <ul style="list-style-type: none"> <li>Check ATF condition. (See 05-17-17 AUTOMATIC TRANSAXLE FLUID (ATF) INSPECTION.)</li> <li>Is it okay?</li> </ul>	Yes	Go to next step.
		No	Replace transaxle, then go to Step 8.
3	<b>CHECK ATF LEVEL</b> <ul style="list-style-type: none"> <li>Start engine.</li> <li>Warm up ATX.</li> <li>Is ATF level within specification? (See 05-17-17 AUTOMATIC TRANSAXLE FLUID (ATF) INSPECTION.)</li> </ul>	Yes	Go to next step.
		No	Adjust ATF level, then go to Step 8.
4	<b>INSPECTION SHIFT SOLENOID VALVE A, B AND C FOR CLICK SOUND</b> <ul style="list-style-type: none"> <li>Perform inspection of operation. (See 05-17-28 SOLENOID VALVES INSPECTION.)</li> <li>Verify the click sound of shift solenoid A, B, and C when applying B+ to each transaxle connector terminal.</li> <li>Was click heard from solenoids?</li> </ul>	Yes	Go to next step.
		No	Replace solenoid that you could not hear click sound, then go to Step 8. (See 05-17-30 SOLENOID VALVES REMOVAL/INSTALLATION.)

## ON-BOARD DIAGNOSTIC

STEP	INSPECTION	ACTION	
5	<b>INSPECT LINE PRESSURE</b> <ul style="list-style-type: none"> <li>• Start engine.</li> <li>• Measure line pressures.</li> </ul> <b>Specification</b> <b>FS engine</b> <b>Idle: 330—470 kPa {3.4—4.7 kgf/cm<sup>2</sup>, 49—66 psi}</b> <b>Stall: 1,160—1,320 kPa {11.9—13.4 kgf/cm<sup>2</sup>, 170—190 psi}</b> <b>ZM engine</b> <b>Idle: 330—470 kPa {3.4—4.7 kgf/cm<sup>2</sup>, 49—66 psi}</b> <b>Stall: 1,200—1,360 kPa {12.3—13.8 kgf/cm<sup>2</sup>, 175—196 psi}</b> <ul style="list-style-type: none"> <li>• Is line pressure within specification? (See 05-17-12 Line Pressure Test.)</li> </ul>	Yes	Go to next step.
		No	All ranges: Replace oil pump, then go to Step 8. Any ranges: Replace control valve body, then go to Step 8. (See 05-17-36 CONTROL VALVE BODY REMOVAL/INSTALLATION.)
6	<b>INSPECT STALL SPEED</b> <ul style="list-style-type: none"> <li>• Measure stall speed in D range. (See 05-17-13 Stall Test.)</li> </ul> <b>Specification</b> <b>FS engine: 2,200—2,500 rpm</b> <b>ZM engine: 2,300—2,600 rpm</b> <ul style="list-style-type: none"> <li>• Is stall speed within specification?</li> </ul>	Yes	Go to next step.
		No	Replace automatic transaxle, then go to Step 8. (See 05-17-31 AUTOMATIC TRANSAXLE (ATX) REMOVAL/INSTALLATION.)
7	<b>INSPECT FREQUENCY OF INPUT/TURBINE SPEED SENSOR WHEN DRIVING VEHICLE</b> <ul style="list-style-type: none"> <li>• Turn ignition key to OFF.</li> <li>• Connect WDS or equivalent.</li> <li>• Start engine.</li> <li>• Measure frequency of input/turbine speed sensor while driving vehicle under the following conditions:                             <ul style="list-style-type: none"> <li>— Vehicle speed: <b>40 km/h {24 mph}</b> (VSS PID)</li> <li>— Drive in D range, 2nd gear</li> <li>— Throttle opening angle: <b>about 25% (TP PID)</b></li> </ul> </li> <li>• Was frequency of input/turbine speed sensor at <b>approx. 1,156 Hz</b>?</li> </ul>	Yes	Go to next step.
		No	Replace control valve body, then go to next step. (See 05-17-36 CONTROL VALVE BODY REMOVAL/INSTALLATION.)
8	<b>VERIFY REPAIR OF DTC P0732</b> <ul style="list-style-type: none"> <li>• Make sure to reconnect all disconnected connectors.</li> <li>• Clear DTC using WDS or equivalent.</li> <li>• Start engine.</li> <li>• Warm up transaxle.</li> <li>• Drive vehicle under the following conditions for <b>more than 15 seconds</b>.                             <ul style="list-style-type: none"> <li>— ATF temperature: <b>20 °C {68 °F} or above</b></li> <li>— Drive in D range, 2nd gear</li> <li>— Vehicle speed (VSS PID): <b>3.8 km/h {2.4 mph} or above</b></li> </ul> </li> <li>• Are any DTCs present?</li> </ul>	Yes	Replace PCM, then go to next step.
		No	Go to next step.
9	<b>VERIFY AFTER REPAIR PROCEDURE</b> <ul style="list-style-type: none"> <li>• Perform “After Repair Procedure”. (See 05-02-6 AFTER REPAIR PROCEDURE.)</li> <li>• Are any DTCs present?</li> </ul>	Yes	Go to applicable DTC inspection.
		No	Troubleshooting completed.

05-02

# ON-BOARD DIAGNOSTIC

DTC P0733

A3U050201030W14

DTC P0733	Gear 3 incorrect (Incorrect Gear Ratio Detected)
<b>DETECTION CONDITION</b>	<ul style="list-style-type: none"> <li>PCM monitors revolution ratio of forward clutch drum revolution to differential gear case revolution when the following monitoring conditions are met. If revolution ratio is <b>below 0.863 or above 1.249</b>, PCM determines that there is malfunction.</li> </ul> <p><b>Monitoring condition:</b></p> <ul style="list-style-type: none"> <li>— ATF temperature <b>20 °C {68 °F} or above.</b></li> <li>— Driving in 3 GR in D range.</li> <li>— Engine run.</li> <li>— Turbine speed <b>within 225—4,988 rpm.</b></li> <li>— Differential gear case (output) revolution speed <b>35 rpm or above.</b></li> <li>— Any of the following not generated: DTC P0500, P0705, P0706, P0710, P0715, P0751, P0752, P0753, P0756, P0757, P0758, P0761, P0762, P0763, P0766, P0767, P0768, P0771, P0772, P0773.</li> </ul> <p><b>Diagnostic support note:</b></p> <ul style="list-style-type: none"> <li>This is a continuous monitor (CCM).</li> <li>MIL does not illuminate.</li> <li>O/D OFF indicator light flashes if PCM detects the above malfunction condition during first drive cycle.</li> <li>FREEZE FRAME DATA is not available.</li> <li>Pending code is not available.</li> <li>DTC stored in the PCM memory.</li> </ul>
<b>POSSIBLE CAUSE</b>	<ul style="list-style-type: none"> <li>ATF level low</li> <li>Deteriorated ATF</li> <li>Shift solenoids A or C stuck</li> <li>Pressure control solenoid stuck</li> <li>Line pressure low</li> <li>3-4 clutch slipping</li> <li>Forward clutch slipping</li> <li>Control valve stuck (Bypass, TCC or 3-4 shift valve)</li> <li>Oil pump</li> <li>PCM malfunction</li> </ul>

## Diagnostic procedure

STEP	INSPECTION		ACTION
1	<b>VERIFY RELATED REPAIR INFORMATION AVAILABILITY</b> <ul style="list-style-type: none"> <li>Check for related Service Bulletins availability.</li> <li>Is any related repair information available?</li> </ul>	Yes	Perform repair or diagnosis according to available repair information.
		No	Go to next step.
2	<b>CHECK ATF CONDITION</b> <ul style="list-style-type: none"> <li>Check ATF condition. (See 05–17–17 AUTOMATIC TRANSAXLE FLUID (ATF) INSPECTION.)</li> <li>Is it okay?</li> </ul>	Yes	Go to next step.
		No	Replace transaxle, then go to Step 8.
3	<b>CHECK ATF LEVEL</b> <ul style="list-style-type: none"> <li>Start engine.</li> <li>Warm up ATX.</li> <li>Is ATF level within specification? (See 05–17–17 AUTOMATIC TRANSAXLE FLUID (ATF) INSPECTION.)</li> </ul>	Yes	Go to next step.
		No	Adjust ATF level, then go to Step 8.
4	<b>INSPECTION SHIFT SOLENOID VALVE A AND C FOR CLICK SOUND</b> <ul style="list-style-type: none"> <li>Perform inspection of operation. (See 05–17–28 SOLENOID VALVES INSPECTION.)</li> <li>Verify the click sound of shift solenoid A and C when applying B+ to each transaxle connector terminal.</li> <li>Was click heard from solenoids?</li> </ul>	Yes	Go to next step.
		No	Replace solenoid that you could not hear click sound, then go to Step 8. (See 05–17–30 SOLENOID VALVES REMOVAL/ INSTALLATION.)



## ON-BOARD DIAGNOSTIC

STEP	INSPECTION	ACTION	
5	<b>INSPECT LINE PRESSURE</b> <ul style="list-style-type: none"> <li>Start engine.</li> <li>Measure line pressures.</li> </ul> <b>Specification</b> <b>FS engine</b> <b>Idle: 330—470 kPa {3.4—4.7 kgf/cm<sup>2</sup>, 49—66 psi}</b> <b>Stall: 1,160—1,320 kPa {11.9—13.4 kgf/cm<sup>2</sup>, 170—190 psi}</b> <b>ZM engine</b> <b>Idle: 330—470 kPa {3.4—4.7 kgf/cm<sup>2</sup>, 49—66 psi}</b> <b>Stall: 1,200—1,360 kPa {12.3—13.8 kgf/cm<sup>2</sup>, 175—196 psi}</b> <ul style="list-style-type: none"> <li>Is line pressure within specification? (See 05-17-12 Line Pressure Test.)</li> </ul>	Yes	Go to next step.
		No	All ranges: Replace oil pump, then go to Step 8. Any ranges: Replace control valve body, then go to Step 8. (See 05-17-36 CONTROL VALVE BODY REMOVAL/INSTALLATION.)
6	<b>INSPECT STALL SPEED</b> <ul style="list-style-type: none"> <li>Measure stall speed in D range. (See 05-17-13 Stall Test.)</li> </ul> <b>Specification</b> <b>FS engine: 2,200—2,500 rpm</b> <b>ZM engine: 2,300—2,600 rpm</b> <ul style="list-style-type: none"> <li>Is stall speed within specification?</li> </ul>	Yes	Go to next step.
		No	Replace automatic transaxle, then go to Step 8. (See 05-17-31 AUTOMATIC TRANSAXLE (ATX) REMOVAL/INSTALLATION.)
7	<b>INSPECT FREQUENCY OF INPUT/TURBINE SPEED SENSOR WHEN DRIVING VEHICLE</b> <ul style="list-style-type: none"> <li>Turn ignition key to OFF.</li> <li>Connect WDS or equivalent.</li> <li>Start engine.</li> <li>Measure frequency of input/turbine speed sensor while driving vehicle under the following conditions:                             <ul style="list-style-type: none"> <li>Vehicle speed (VSS PID): <b>60 km/h {37 mph}</b></li> <li>Drive in D range, 3rd gear</li> <li>Throttle opening angle (TP PID): <b>about 25%</b></li> </ul> </li> <li>Was frequency of input/turbine speed sensor at <b>approx. 1,158 Hz?</b></li> </ul>	Yes	Go to next step.
		No	Replace control valve body, then go to next step. (See 05-17-36 CONTROL VALVE BODY REMOVAL/INSTALLATION.)
8	<b>VERIFY REPAIR OF DTC P0732</b> <ul style="list-style-type: none"> <li>Make sure to reconnect all disconnected connectors.</li> <li>Clear DTC using WDS or equivalent.</li> <li>Start engine.</li> <li>Warm up transaxle.</li> <li>Drive vehicle under the following conditions for <b>more than 15 seconds</b>.                             <ul style="list-style-type: none"> <li>ATF temperature: <b>20 °C {68 °F} or above</b></li> <li>Drive in D range, 3rd gear</li> <li>Vehicle speed (VSS PID): <b>4 km/h {3 mph} or above</b></li> </ul> </li> <li>Are any DTCs present?</li> </ul>	Yes	Replace PCM, then go to next step.
		No	Go to next step.
9	<b>VERIFY AFTER REPAIR PROCEDURE</b> <ul style="list-style-type: none"> <li>Perform "After Repair Procedure". (See 05-02-6 AFTER REPAIR PROCEDURE.)</li> <li>Are any DTCs present?</li> </ul>	Yes	Go to applicable DTC inspection.
		No	Troubleshooting completed.

05-02

# ON-BOARD DIAGNOSTIC

DTC P0734

A3U050201030W15

DTC P0734	Gear 4 incorrect (Incorrect Gear Ratio Detected)
<b>DETECTION CONDITION</b>	<ul style="list-style-type: none"> <li>PCM monitors revolution ratio of forward clutch drum revolution to differential gear case revolution when the following monitoring conditions are met. If revolution ratio is <b>below 0.6 or above 1.249</b>, PCM determines that there is malfunction.</li> </ul> <p><b>Monitoring condition:</b></p> <ul style="list-style-type: none"> <li>— ATF temperature <b>20 °C {68 °F} or above.</b></li> <li>— Driving in 4 GR in D range.</li> <li>— Engine run.</li> <li>— Turbine speed <b>within 225—4,988 rpm.</b></li> <li>— Vehicle speed <b>50 km/h {31 mph} or above.</b></li> <li>— Closed throttle position.</li> <li>— Differential gear case (output) revolution speed <b>35 rpm or above.</b></li> <li>— Any of the following not generated: DTC P0500, P0705, P0706, P0710, P0715, P0751, P0752, P0753, P0756, P0757, P0758, P0761, P0762, P0763, P0766, P0767, P0768, P0771, P0772, P0773.</li> </ul> <p><b>Diagnostic support note:</b></p> <ul style="list-style-type: none"> <li>This is a continuous monitor (CCM).</li> <li>MIL does not illuminate.</li> <li>O/D OFF indicator light flashes if PCM detects the above malfunction condition during first drive cycle.</li> <li>FREEZE FRAME DATA is not available.</li> <li>Pending code is not available.</li> <li>DTC stored in the PCM memory.</li> </ul>
<b>POSSIBLE CAUSE</b>	<ul style="list-style-type: none"> <li>ATF level low</li> <li>Deteriorated ATF</li> <li>Shift solenoids A, B or C stuck</li> <li>Pressure control solenoid stuck</li> <li>Line pressure low</li> <li>2-4 brake band slipping</li> <li>3-4 clutch slipping</li> <li>Forward clutch slipping</li> <li>Control valve stuck (Bypass or 3-4 shift valve)</li> <li>Oil pump</li> <li>PCM malfunction</li> </ul>

## Diagnostic procedure

STEP	INSPECTION		ACTION
1	<b>VERIFY RELATED REPAIR INFORMATION AVAILABILITY</b> <ul style="list-style-type: none"> <li>Check for related Service Bulletins availability.</li> <li>Is any related repair information available?</li> </ul>	Yes	Perform repair or diagnosis according to available repair information.
		No	Go to next step.
2	<b>CHECK ATF CONDITION</b> <ul style="list-style-type: none"> <li>Check ATF condition. (See 05–17–17 AUTOMATIC TRANSAXLE FLUID (ATF) INSPECTION.)</li> <li>Is it okay?</li> </ul>	Yes	Go to next step.
		No	Replace transaxle, then go to Step 8.
3	<b>CHECK ATF LEVEL</b> <ul style="list-style-type: none"> <li>Start engine.</li> <li>Warm up ATX.</li> <li>Is ATF level within specification? (See 05–17–17 AUTOMATIC TRANSAXLE FLUID (ATF) INSPECTION.)</li> </ul>	Yes	Go to next step.
		No	Adjust ATF level, then go to Step 8.
4	<b>INSPECT SHIFT SOLENOID VALVE A AND D FOR CLICK SOUND</b> <ul style="list-style-type: none"> <li>Perform inspection of operation. (See 05–17–28 SOLENOID VALVES INSPECTION.)</li> <li>Verify the click sound of shift solenoids A and D when applying B+ to each transaxle connector terminal.</li> </ul> <p><b>Note</b></p> <ul style="list-style-type: none"> <li>Click from solenoid D is barely audible. Remove solenoids to correctly inspect if necessary.</li> </ul> <ul style="list-style-type: none"> <li>Was click heard from solenoids?</li> </ul>	Yes	Go to next step.
		No	Replace solenoid that you could not hear click sound, then go to Step 8. (See 05–17–30 SOLENOID VALVES REMOVAL/ INSTALLATION.)

## ON-BOARD DIAGNOSTIC

STEP	INSPECTION	ACTION	
5	<b>INSPECT LINE PRESSURE</b> <ul style="list-style-type: none"> <li>• Start engine.</li> <li>• Measure line pressures.</li> </ul> <b>Specification</b> <b>FS engine</b> <b>Idle: 330—470 kPa {3.4—4.7 kgf/cm<sup>2</sup>, 49—66 psi}</b> <b>Stall: 1,160—1,320 kPa {11.9—13.4 kgf/cm<sup>2</sup>, 170—190 psi}</b> <b>ZM engine</b> <b>Idle: 330—470 kPa {3.4—4.7 kgf/cm<sup>2</sup>, 49—66 psi}</b> <b>Stall: 1,200—1,360 kPa {12.3—13.8 kgf/cm<sup>2</sup>, 175—196 psi}</b> <ul style="list-style-type: none"> <li>• Is line pressure within specification?</li> </ul> (See 05-17-12 Line Pressure Test.)	Yes	Go to next step.
		No	All ranges: Replace oil pump, then go to Step 8. Any ranges: Replace control valve body, then go to Step 8. (See 05-17-36 CONTROL VALVE BODY REMOVAL/INSTALLATION.)
6	<b>INSPECT STALL SPEED</b> <ul style="list-style-type: none"> <li>• Measure stall speed in D range. (See 05-17-13 Stall Test.)</li> </ul> <b>Specification</b> <b>FS engine: 2,200—2,500 rpm</b> <b>ZM engine: 2,300—2,600 rpm</b> <ul style="list-style-type: none"> <li>• Is stall speed within specification?</li> </ul>	Yes	Go to next step.
		No	Replace automatic transaxle, then go to Step 8. (See 05-17-31 AUTOMATIC TRANSAXLE (ATX) REMOVAL/INSTALLATION.)
7	<b>INSPECT FREQUENCY OF INPUT/TURBINE SPEED SENSOR WHEN DRIVING VEHICLE</b> <ul style="list-style-type: none"> <li>• Turn ignition key to OFF.</li> <li>• Connect WDS or equivalent.</li> <li>• Start engine.</li> <li>• Measure frequency of input/turbine speed sensor while driving vehicle under the following conditions:                             <ul style="list-style-type: none"> <li>— Vehicle speed (VSS PID): <b>80 km/h {49 mph}</b></li> <li>— Drive in D range, 4th gear</li> <li>— Throttle opening angle (TP PID): <b>about 25%</b></li> </ul> </li> <li>• Was frequency of input/turbine speed sensor at <b>approx. 1,120 Hz?</b></li> </ul>	Yes	Go to next step.
		No	Replace control valve body, then go to next step. (See 05-17-36 CONTROL VALVE BODY REMOVAL/INSTALLATION.)
8	<b>VERIFY REPAIR OF DTC P0732</b> <ul style="list-style-type: none"> <li>• Make sure to reconnect all disconnected connectors.</li> <li>• Clear DTC using WDS or equivalent.</li> <li>• Start engine.</li> <li>• Warm up transaxle.</li> <li>• Drive vehicle under the following conditions for <b>more than 15 seconds</b>.                             <ul style="list-style-type: none"> <li>— ATF temperature: <b>20 °C {68 °F} or above</b></li> <li>— Drive in D range, 4th gear</li> <li>— Throttle opening angle (TP PID): <b>0%</b></li> <li>— Vehicle speed (VSS PID): <b>50 km/h {31 mph} or above</b></li> </ul> </li> <li>• Are any DTCs present?</li> </ul>	Yes	Replace PCM, then go to next step.
		No	Go to next step.
9	<b>VERIFY AFTER REPAIR PROCEDURE</b> <ul style="list-style-type: none"> <li>• Are any DTCs present?</li> <li>• Perform "After Repair Procedure". (See 05-02-6 AFTER REPAIR PROCEDURE.)</li> </ul>	Yes	Go to applicable DTC inspection.
		No	Troubleshooting completed.

05-02

# ON-BOARD DIAGNOSTIC

DTC P0741

A3U050201030W16

DTC P0741	Torque converter clutch (TCC) stuck OFF
<b>DETECTION CONDITION</b>	<ul style="list-style-type: none"> <li>• When all conditions below satisfied.                             <ul style="list-style-type: none"> <li>— ATF temperature <b>20 °C {68 °F} or above.</b></li> <li>— Driving in 4GR at D range.</li> <li>— Engine run.</li> <li>— Turbine speed <b>within 225—4,988 rpm.</b></li> <li>— Vehicle speed <b>within 60—100 km/h {37—62 mph}.</b></li> <li>— TCC operation</li> <li>— Shift solenoid A duty value exceeds <b>99%</b></li> <li>— Power or normal mode</li> <li>— Difference between engine speed and turbine speed <b>more than 100 rpm</b></li> <li>— Any of the following not generated: DTC P0500, P0705, P0706, P0710, P0715, P0751, P0752, P0753, P0756, P0757, P0758, P0761, P0762, P0763, P0766, P0767, P0768, P0771, P0772, P0773.</li> </ul> </li> </ul> <p><b>Diagnostic support note:</b></p> <ul style="list-style-type: none"> <li>• This is a continuous monitor (CCM).</li> <li>• MIL does not illuminate if PCM detects the above malfunction conditions during first drive cycle.</li> <li>• PENDING CODE is not available.</li> <li>• FREEZE FRAME DATA is not available.</li> <li>• O/D OFF indicator light flashes.</li> <li>• DTC is stored in the PCM memory.</li> </ul>
<b>POSSIBLE CAUSE</b>	<ul style="list-style-type: none"> <li>• ATF level low</li> <li>• Deteriorated ATF</li> <li>• Shift solenoids A, B, C, D, E, and pressure control solenoid stuck</li> <li>• Line pressure low</li> <li>• 2-4 brake band slipping</li> <li>• 3-4 clutch slipping</li> <li>• Control valve stuck.</li> <li>• PCM malfunction</li> </ul>

## Diagnostic procedure

STEP	INSPECTION		ACTION
1	<b>VERIFY RELATED REPAIR INFORMATION AVAILABILITY</b> <ul style="list-style-type: none"> <li>• Check for related Service Bulletins availability.</li> <li>• Is any related repair information available?</li> </ul>	Yes	Perform repair or diagnosis according to available repair information. <ul style="list-style-type: none"> <li>• If vehicle is not repaired, go to next step.</li> </ul>
		No	Go to next step.
2	<b>CHECK ATF CONDITION</b> <ul style="list-style-type: none"> <li>• Turn ignition key to OFF.</li> <li>• Check ATF condition.                                     <ul style="list-style-type: none"> <li>— Clear red: Normal</li> <li>— Milky: Water mixed in fluid</li> <li>— Reddish brown: Deteriorated ATF</li> </ul> </li> <li>• Is it okay?</li> </ul> (See 05–17–17 Automatic Transaxle Fluid (ATF) Condition Inspection.)	Yes	Go to next step.
		No	If ATF color milky or reddish brown, replace ATF, then go to Step 4. (See 05–17–18 AUTOMATIC TRANSAXLE FLUID (ATF) REPLACEMENT.)
3	<b>CHECK ATF LEVEL</b> <ul style="list-style-type: none"> <li>• Start engine.</li> <li>• Warm up ATX.</li> <li>• Is ATF level within specification?</li> </ul> (See 05–17–18 Automatic Transaxle Fluid (ATF) Level Inspection.)	Yes	Go to next step.
		No	Adjust ATF level, then go to Step 6. (See 05–17–18 Automatic Transaxle Fluid (ATF) Level Inspection.)
4	<b>INSPECT LINE PRESSURE</b> <ul style="list-style-type: none"> <li>• Start engine.</li> <li>• Measure line pressure.</li> </ul> <b>Specification</b> <b>FS engine</b> Idle: 330—470 kPa {3.4—4.7 kgf/cm <sup>2</sup> , 49—66 psi} Stall: 1,160—1,320 kPa {11.9—13.4 kgf/cm <sup>2</sup> , 170—190 psi} <b>ZM engine</b> Idle: 330—470 kPa {3.4—4.7 kgf/cm <sup>2</sup> , 49—66 psi} Stall: 1,200—1,360 kPa {12.3—13.8 kgf/cm <sup>2</sup> , 175—169 psi} <ul style="list-style-type: none"> <li>• Is line pressure within specification?</li> </ul> (See 05–17–12 Line Pressure Test.)	Yes	Go to next step.
		No	<ul style="list-style-type: none"> <li>• All ranges: Replace oil pump or control valve body, then go to Step 6.</li> <li>• Any ranges: Replace ATX, then go to Step 6. (See 05–17–31 AUTOMATIC TRANSAXLE (ATX) REMOVAL/INSTALLATION.) (See ATX Workshop Manual FN4A-EL (9999-95-FN4A-99).)</li> </ul>

## ON-BOARD DIAGNOSTIC

STEP	INSPECTION	ACTION	
5	<b>CHECK OPERATION OF EACH VALVE AND EACH SPRING</b> <ul style="list-style-type: none"> <li>• Turn ignition key to OFF.</li> <li>• Remove control valve body.</li> <li>• Disassemble control valve body.</li> <li>• Is each valve operation okay and is return spring okay?</li> </ul> (See 05-17-36 CONTROL VALVE BODY REMOVAL/INSTALLATION.) (See ATX Workshop Manual FN4A-EL (9999-95-FN4A-99).)	Yes	Replace ATX, then go to next step (See ATX Workshop Manual FN4A-EL (9999-95-FN4A-99).)
		No	Repair or replace shift valve and return spring, then go to next step. (See 05-17-36 CONTROL VALVE BODY REMOVAL/INSTALLATION.) (See ATX Workshop Manual FN4A-EL (9999-95-FN4A-99).)
6	<b>VERIFY TROUBLESHOOTING OF DTC P0741 COMPLETED</b> <ul style="list-style-type: none"> <li>• Make sure to reconnect all disconnected connectors.</li> <li>• Clear DTC from memory using WDS or equivalent.</li> <li>• Start engine.</li> <li>• Warm up engine and ATX.</li> <li>• Drive vehicle under following conditions for <b>15 seconds or more</b>.                             <ul style="list-style-type: none"> <li>— ATF temperature: <b>20 °C {68 °F} or above</b></li> <li>— Drive in D range, 4th gear (TCC operation)</li> <li>— Vehicle speed (VSS PID): <b>within 60—100 km/h {37—62 mph}</b></li> </ul> </li> <li>• Are any DTCs present?</li> </ul>	Yes	Replace PCM, then go to next step. (See 01-40A-7 PCM REMOVAL/INSTALLATION [ZM].) (See 01-40B-7 PCM REMOVAL/INSTALLATION [FS].)
		No	Go to next step.
7	<b>VERIFY AFTER REPAIR PROCEDURE</b> <ul style="list-style-type: none"> <li>• Perform "After Repair Procedure". (See 05-02-6 AFTER REPAIR PROCEDURE.)</li> <li>• Are any DTCs present?</li> </ul>	Yes	Go to applicable DTC inspection.
		No	Troubleshooting completed.

05-02

### DTC P0742

A3U050201030W17

DTC P0742	Torque converter clutch (TCC) stuck ON
<b>DETECTION CONDITION</b>	<ul style="list-style-type: none"> <li>• All of following conditions satisfied under each of following throttle conditions.                             <ul style="list-style-type: none"> <li>— ATF temperature <b>20 °C {68 °F} or above</b>.</li> <li>— Driving in 4GR at D range.</li> <li>— Engine run.</li> <li>— Turbine speed <b>within 225—4,988 rpm</b>.</li> <li>— Vehicle speed <b>below 70 km/h {43 mph}</b>.</li> <li>— Torque converter clutch (TCC) no operation</li> <li>— Difference between engine speed and turbine speed <b>below 50 rpm</b></li> <li>— DTC P0734 not output</li> </ul> </li> <li>• Throttle conditions.                             <ul style="list-style-type: none"> <li>— <b>FS engine</b> <ul style="list-style-type: none"> <li>• Throttle opening angle (TP PID) <b>above 6.25%</b> and <b>10 seconds or more</b> have passed.</li> <li>• Throttle opening angle (TP PID) <b>within 3.13—6.25%</b> and <b>3 seconds or more</b> have passed.</li> <li>• Throttle opening angle at closed throttle position and <b>10 seconds or more</b> have passed.</li> </ul> </li> <li>— <b>ZM engine</b> <ul style="list-style-type: none"> <li>• Throttle opening angle (TP PID) <b>above 7.03%</b> and <b>10 seconds or more</b> have passed.</li> <li>• Throttle opening angle (TP PID) <b>within 1.56—7.03%</b> and <b>3 seconds or more</b> have passed.</li> <li>• Throttle opening angle at closed throttle position and <b>10 seconds or more</b> have passed.</li> </ul> </li> </ul> </li> </ul> <p><b>Diagnostic support note:</b></p> <ul style="list-style-type: none"> <li>• This is a continuous monitor (CCM).</li> <li>• MIL does not illuminate if PCM detects the above malfunction conditions during first drive cycle.</li> <li>• PENDING CODE is not available.</li> <li>• FREEZE FRAME DATA is not available.</li> <li>• O/D OFF indicator light flashes.</li> <li>• DTC is stored in the PCM memory.</li> </ul>
<b>POSSIBLE CAUSE</b>	<ul style="list-style-type: none"> <li>• ATF level low</li> <li>• Deteriorated ATF</li> <li>• Shift solenoids A, B, C, D, E, and pressure control solenoid stuck</li> <li>• Line pressure low</li> <li>• 2-4 brake band slipping</li> <li>• 3-4 clutch slipping</li> <li>• Control valve stuck</li> <li>• PCM malfunction</li> </ul>

## ON-BOARD DIAGNOSTIC

### Diagnostic procedure

STEP	INSPECTION	ACTION	
1	<b>VERIFY RELATED REPAIR INFORMATION AVAILABILITY</b> <ul style="list-style-type: none"> <li>• Check for related Service Bulletins availability.</li> <li>• Is any related repair information available?</li> </ul>	Yes	Perform repair or diagnosis according to available repair information. <ul style="list-style-type: none"> <li>• If vehicle is not repaired, go to next step.</li> </ul>
		No	Go to next step.
2	<b>CHECK ATF CONDITION</b> <ul style="list-style-type: none"> <li>• Turn ignition key to OFF.</li> <li>• Check ATF condition.               <ul style="list-style-type: none"> <li>— Clear red: Normal</li> <li>— Milky: Water mixed in fluid</li> <li>— Reddish brown: Deteriorated ATF</li> </ul> </li> <li>• Is it okay?</li> </ul> (See 05–17–17 Automatic Transaxle Fluid (ATF) Condition Inspection.)	Yes	Go to next step.
		No	If ATF color milky or reddish brown, replace ATF, then go to Step 4. (See 05–17–18 AUTOMATIC TRANSAXLE FLUID (ATF) REPLACEMENT.)
3	<b>CHECK ATF LEVEL</b> <ul style="list-style-type: none"> <li>• Start engine.</li> <li>• Warm up ATX.</li> <li>• Is ATF level within specification?</li> </ul> (See 05–17–18 Automatic Transaxle Fluid (ATF) Level Inspection.)	Yes	Go to next step.
		No	Adjust ATF level, then go to Step 6. (See 05–17–18 Automatic Transaxle Fluid (ATF) Level Inspection.)
4	<b>INSPECT LINE PRESSURE</b> <ul style="list-style-type: none"> <li>• Start engine.</li> <li>• Measure line pressure.</li> </ul> <b>Specification</b> <b>FS engine</b> <b>Idle: 330—470 kPa {3.4—4.7 kgf/cm<sup>2</sup>, 49—66 psi}</b> <b>Stall: 1,160—1,320 kPa {11.9—13.4 kgf/cm<sup>2</sup>, 170—190 psi}</b> <b>ZM engine</b> <b>Idle: 330—470 kPa {3.4—4.7 kgf/cm<sup>2</sup>, 49—66 psi}</b> <b>Stall: 1,200—1,360 kPa {12.3—13.8 kgf/cm<sup>2</sup>, 175—196 psi}</b> <ul style="list-style-type: none"> <li>• Is line pressure within specification?</li> </ul> (See 05–17–12 Line Pressure Test.)	Yes	Go to next step.
		No	<ul style="list-style-type: none"> <li>• All ranges: Replace oil pump or control valve body, then go to Step 6.</li> <li>• Any ranges: Replace ATX, then go to Step 6. (See 05–17–31 AUTOMATIC TRANSAXLE (ATX) REMOVAL/INSTALLATION.) (See ATX Workshop Manual FN4A-EL (9999-95-FN4A-99).)</li> </ul>
5	<b>CHECK OPERATION OF EACH VALVE AND EACH SPRING</b> <ul style="list-style-type: none"> <li>• Turn ignition key to OFF.</li> <li>• Remove control valve body.</li> <li>• Disassemble control valve body.</li> <li>• Is each valve operation okay and is return spring okay?</li> </ul> (See 05–17–36 CONTROL VALVE BODY REMOVAL/INSTALLATION.) (See ATX Workshop Manual FN4A-EL (9999-95-FN4A-99).)	Yes	Replace ATX, then go to next step (See ATX Workshop Manual FN4A-EL (9999-95-FN4A-99).)
		No	Repair or replace shift valve and return spring, then go to next step. (See 05–17–36 CONTROL VALVE BODY REMOVAL/INSTALLATION.) (See ATX Workshop Manual FN4A-EL (9999-95-FN4A-99).)

## ON-BOARD DIAGNOSTIC

STEP	INSPECTION	ACTION	
6	<p><b>VERIFY TROUBLESHOOTING OF DTC P0742 COMPLETED</b></p> <ul style="list-style-type: none"> <li>• Make sure to reconnect all disconnected connectors.</li> <li>• Clear DTC from memory using WDS or equivalent.</li> <li>• Start engine.</li> <li>• Warm up engine and ATX.</li> <li>• Drive vehicle under following.                             <ul style="list-style-type: none"> <li>— ATF temperature: <b>20 °C {68 °F} or above</b></li> <li>— Drive in D range, 4th gear (TCC operation)</li> <li>— Vehicle speed: <b>below 70 km/h {43 mph}</b>.</li> </ul> </li> <li>• Throttle conditions                             <ul style="list-style-type: none"> <li>— <b>FS engine</b> <ul style="list-style-type: none"> <li>• Throttle opening angle (TP PID) <b>above 6.25% and 10 seconds or more</b> have passed.</li> <li>• Throttle opening angle (TP PID) <b>within 3.13—6.25% and 3 seconds or more</b> have passed.</li> <li>• Throttle opening angle at closed throttle position and <b>10 seconds or more</b> have passed.</li> </ul> </li> <li>— <b>ZM engine</b> <ul style="list-style-type: none"> <li>• Throttle opening angle (TP PID) <b>7.03% and 10 seconds or more</b> have passed.</li> <li>• Throttle opening angle (TP PID) <b>within 1.56—7.03% and 3 seconds or more</b> have passed.</li> <li>• Throttle opening angle at closed throttle position and <b>10 seconds or more</b> have passed.</li> </ul> </li> </ul> </li> <li>• Are any DTCs present?</li> </ul>	Yes	Replace PCM, then go to next step. (See 01-40A-7 PCM REMOVAL/INSTALLATION [ZM].) (See 01-40B-7 PCM REMOVAL/INSTALLATION [FS].)
		No	Go to next step.
7	<p><b>VERIFY AFTER REPAIR PROCEDURE</b></p> <ul style="list-style-type: none"> <li>• Perform “After Repair Procedure”. (See 05-02-6 AFTER REPAIR PROCEDURE.)</li> <li>• Are any DTCs present?</li> </ul>	Yes	Go to applicable DTC inspection.
		No	Troubleshooting completed.

05-02

# ON-BOARD DIAGNOSTIC

**DTC P0745**

A3U050201030W18

<b>DTC P0745</b>	<b>Pressure control solenoid malfunction</b>
<b>DETECTION CONDITION</b>	<ul style="list-style-type: none"> <li>• If PCM detects either of following conditions, PCM determines that pressure control solenoid circuit has a malfunction                             <ul style="list-style-type: none"> <li>— Pressure control solenoid voltage stuck <b>0 V</b> after engine start</li> <li>— Pressure control solenoid voltage stuck <b>B+</b> after engine start</li> </ul> </li> </ul> <p><b>Diagnostic support note:</b></p> <ul style="list-style-type: none"> <li>• This is a continuous monitor (CCM).</li> <li>• MIL does not illuminate if PCM detects above malfunction conditions during first drive cycle.</li> <li>• PENDING CODE is not available.</li> <li>• FREEZE FRAME DATA is not available.</li> <li>• O/D OFF indicator light flashes.</li> <li>• DTC is stored in the PCM memory.</li> </ul>
<b>POSSIBLE CAUSE</b>	<ul style="list-style-type: none"> <li>• Pressure control solenoid malfunction</li> <li>• Open circuit between pressure control solenoid terminal B and ATX connector terminal I</li> <li>• Open circuit between ATX connector terminal I and PCM terminal 81</li> <li>• Short to ground between ATX connector terminal D and PCM terminal 44</li> <li>• Short to power between ATX connector terminal D and PCM terminal 44</li> <li>• Open circuit between pressure control solenoid terminal A and ATX connector terminal D</li> <li>• Open circuit between ATX connector terminal D and PCM terminal 44</li> <li>• Damaged connector between pressure control solenoid and PCM</li> <li>• PCM malfunction</li> </ul>

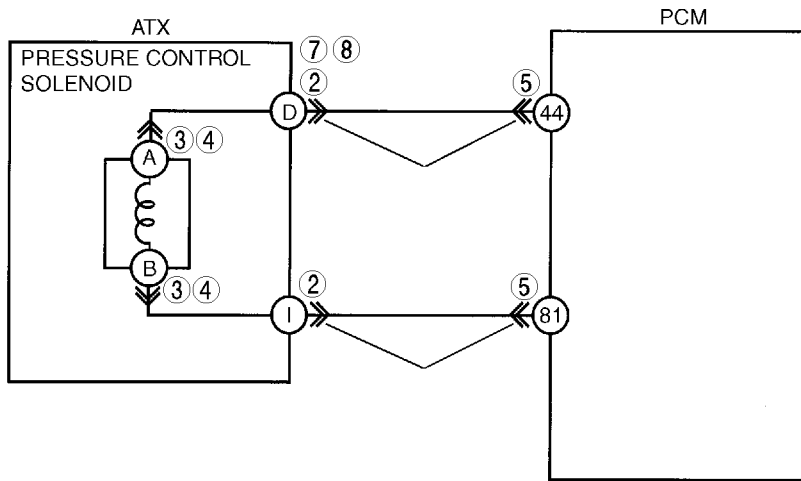

ATX CONNECTOR

PRESSURE CONTROL SOLENOID



HARNESS SIDE CONNECTOR  
(VIEW FROM HARNESS SIDE)

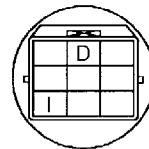

HARNESS SIDE CONNECTOR  
(VIEW FROM HARNESS SIDE)

PCM HARNESS SIDE CONNECTOR

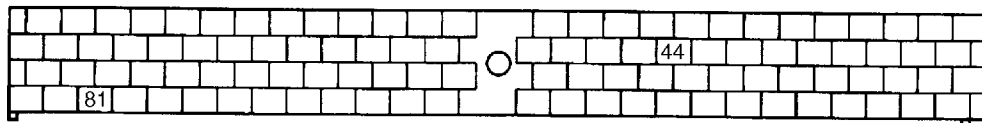

(VIEW FROM TERMINAL SIDE)



# ON-BOARD DIAGNOSTIC

## Diagnostic procedure

STEP	INSPECTION	ACTION	
1	<b>VERIFY RELATED REPAIR INFORMATION AVAILABILITY</b> <ul style="list-style-type: none"> <li>Check for related Service Bulletins availability.</li> <li>Is any related repair information available?</li> </ul>	Yes	Perform repair or diagnosis according to available repair information. <ul style="list-style-type: none"> <li>If vehicle is not repaired, go to next step.</li> </ul>
		No	Go to next step.
2	<b>INSPECT ATX CONNECTOR FOR POOR CONNECTION</b> <ul style="list-style-type: none"> <li>Turn ignition key to OFF.</li> <li>Disconnect ATX connector.</li> <li>Check for poor connection (damaged/pulled-out terminal, corrosion, etc.).</li> <li>Is connection okay?</li> </ul>	Yes	Go to next step.
		No	Repair or replace connector and/or terminals, then go to Step 10.
3	<b>INSPECT RESISTANCE</b> <ul style="list-style-type: none"> <li>Inspect resistance between ATX connector (transaxle case side) terminals D and I.</li> <li>Is resistance <b>within 2.4—7.3 ohms</b>?</li> </ul> (See 05-17-28 Inspection of Resistance (On-vehicle).)	Yes	Go to Step 6.
		No	Go to next step.
4	<b>INSPECT PRESSURE CONTROL SOLENOID CONNECTOR FOR POOR CONNECTION</b> <ul style="list-style-type: none"> <li>Disconnect pressure control solenoid connector.</li> <li>Check for poor connection (damaged/pulled-out terminal, corrosion, etc.).</li> <li>Is connection okay?</li> </ul>	Yes	Go to next step.
		No	Repair or replace connector and/or terminals, then go to Step 10.
5	<b>INSPECT RESISTANCE</b> <ul style="list-style-type: none"> <li>Inspect resistance between pressure control solenoid terminals A and B.</li> <li>Is resistance <b>within 2.4—7.3 ohms</b>?</li> </ul> (See 05-17-28 Inspection of Resistance (On-vehicle).)	Yes	Replace solenoid harness, then go to Step 10.
		No	Verify pressure control solenoid installation. <ul style="list-style-type: none"> <li>If solenoid installed correctly, replace pressure control solenoid, then go to Step 10.</li> </ul> (See 05-17-30 SOLENOID VALVES REMOVAL/INSTALLATION.)
6	<b>INSPECT PCM CONNECTOR FOR POOR CONNECTION</b> <ul style="list-style-type: none"> <li>Disconnect PCM connector.</li> <li>Check for poor connection (damaged/pulled-out terminals, corrosion, etc.).</li> <li>Is connection okay?</li> </ul>	Yes	Go to next step.
		No	Repair or replace connector and/or terminals, then go to Step 10.
7	<b>INSPECT ATX CONNECTOR CIRCUIT FOR OPEN</b> <ul style="list-style-type: none"> <li>Inspect for continuity between PCM (harness-side) and ATX connector (vehicle harness-side).                                     <ul style="list-style-type: none"> <li>PCM terminal 44 and ATX connector terminal D</li> <li>PCM terminal 81 and ATX connector terminal I</li> </ul> </li> <li>Is there continuity between terminals?</li> </ul>	Yes	Go to next step.
		No	Repair or replace harness, the go to Step 10.
8	<b>INSPECT ATX CONNECTOR CIRCUIT FOR SHORT TO POWER</b> <ul style="list-style-type: none"> <li>Turn ignition key to ON (engine OFF).</li> <li>Inspect voltage at ATX connector terminal D (vehicle harness-side).</li> <li>Is voltage <b>0 V</b>?</li> </ul>	Yes	Go to next step.
		No	Repair or replace harness, then go to Step 10.
9	<b>INSPECT PCM CIRCUIT FOR SHORT TO GROUND</b> <ul style="list-style-type: none"> <li>Turn ignition key to OFF.</li> <li>Inspect for continuity between ATX connector terminal D (harness-side) and body ground.</li> <li>Is there continuity?</li> </ul>	Yes	Repair or replace harness, then go to next step.
		No	Go to next step.

05-02

## ON-BOARD DIAGNOSTIC

STEP	INSPECTION	ACTION
10	<b>VERIFY TROUBLESHOOTING OF DTC P0745 COMPLETED</b> <ul style="list-style-type: none"> <li>Make sure to reconnect all disconnected connectors.</li> <li>Clear DTC from memory using WDS or equivalent.</li> <li>Make sure to wait <b>more than 1 second</b> after turning ignition key to ON.</li> <li>Are any DTCs present?</li> </ul>	Yes Replace PCM, then go to next step. (See 01-40A-7 PCM REMOVAL/INSTALLATION [ZM].) (See 01-40B-7 PCM REMOVAL/INSTALLATION [FS].)
		No No concern is detected. Go to next step.
11	<b>VERIFY AFTER REPAIR PROCEDURE</b> <ul style="list-style-type: none"> <li>Perform "After Repair Procedure". (See 05-02-6 AFTER REPAIR PROCEDURE.)</li> <li>Are any DTCs present?</li> </ul>	Yes Go to applicable DTC inspection.
		No Troubleshooting completed.

### DTC P0751

A3U050201030W19

DTC P0751	Shift solenoid A stuck OFF
<b>DETECTION CONDITION</b>	<ul style="list-style-type: none"> <li>When any of P0731, P0732, and P0733 are not generated, and all conditions below satisfied. <ul style="list-style-type: none"> <li>ATF temperature <b>20 °C {68 °F} or above.</b></li> <li>Driving in 4GR at D range.</li> <li>Engine run.</li> <li>Turbine speed <b>within 225— 4,988 rpm.</b></li> <li>Differential gear case (output) revolution speed <b>35 rpm or above.</b></li> <li>Torque converter clutch (TCC) not operating</li> <li>Revolution ratio of forward clutch drum revolution to differential gear case revolution <b>within 0.91—1.09.</b></li> <li>Any of the following not generated: DTC P0500, P0705, P0706, P0710, P0715, P0751, P0752, P0753, P0756, P0757, P0758, P0761, P0762, P0763, P0766, P0767, P0767, P0768, P0771, P0772, P0773.</li> </ul> </li> </ul> <p><b>Diagnostic support note:</b></p> <ul style="list-style-type: none"> <li>This is a continuous monitor (CCM).</li> <li>MIL illuminates if PCM detects the above malfunction conditions during two consecutive drive cycles.</li> <li>PENDING CODE is available.</li> <li>FREEZE FRAME DATA is available.</li> <li>O/D OFF indicator light flashes.</li> <li>DTC is stored in the PCM memory.</li> </ul>
<b>POSSIBLE CAUSE</b>	<ul style="list-style-type: none"> <li>ATF level low</li> <li>Deteriorated ATF</li> <li>Shift solenoid A stuck</li> <li>Control valve stuck</li> <li>PCM malfunction</li> </ul>

### Diagnostic procedure

STEP	INSPECTION	ACTION
1	<b>VERIFY FREEZE FRAME DATA HAS BEEN RECORDED</b> <ul style="list-style-type: none"> <li>Has FREEZE FRAME PID DATA been recorded?</li> </ul>	Yes Go to next step.
		No Record FREEZE FRAME PID DATA on repair order, then go to next step.
2	<b>VERIFY RELATED REPAIR INFORMATION AVAILABILITY</b> <ul style="list-style-type: none"> <li>Check for related Service Bulletins availability.</li> <li>Is any related repair information available?</li> </ul>	Yes Perform repair or diagnosis according to available repair information. <ul style="list-style-type: none"> <li>If vehicle is not repaired, go to next step.</li> </ul>
		No Go to next step.
3	<b>CHECK ATF CONDITION</b> <ul style="list-style-type: none"> <li>Turn ignition key to OFF.</li> <li>Check ATF condition. <ul style="list-style-type: none"> <li>Clear red: Normal</li> <li>Milky: Water mixed in fluid</li> <li>Reddish brown: Deteriorated ATF</li> </ul> </li> <li>Is it okay?</li> </ul> (See 05-17-17 Automatic Transaxle Fluid (ATF) Condition Inspection.)	Yes Go to next step.
		No If ATF color milky or reddish brown, replace ATF, then go to Step 5. (See 05-17-18 AUTOMATIC TRANSAXLE FLUID (ATF) REPLACEMENT.)
4	<b>CHECK ATF LEVEL</b> <ul style="list-style-type: none"> <li>Start engine.</li> <li>Warm up ATX.</li> <li>Is ATF level within specification?</li> </ul> (See 05-17-18 Automatic Transaxle Fluid (ATF) Level Inspection.)	Yes Go to next step.
		No Adjust ATF level, then go to Step 7. (See 05-17-18 Automatic Transaxle Fluid (ATF) Level Inspection.)

## ON-BOARD DIAGNOSTIC

STEP	INSPECTION	ACTION	
5	<b>INSPECT LINE PRESSURE</b> <ul style="list-style-type: none"> <li>• Start engine.</li> <li>• Measure line pressure.</li> </ul> <b>Specification</b> <b>FS engine</b> <b>Idle: 330—470 kPa {3.4—4.7 kgf/cm<sup>2</sup>, 49—66 psi}</b> <b>Stall: 1,160—1,320 kPa {11.9—13.4 kgf/cm<sup>2</sup>, 170—190 psi}</b> <b>ZM engine</b> <b>Idle: 330—470 kPa {3.4—4.7 kgf/cm<sup>2</sup>, 49—66 psi}</b> <b>Stall: 1,200—1,360 kPa {12.3—13.8 kgf/cm<sup>2</sup>, 175—196 psi}</b> <ul style="list-style-type: none"> <li>• Is line pressure within specification? (See 05-17-12 Line Pressure Test.)</li> </ul>	Yes	Go to next step.
		No	<ul style="list-style-type: none"> <li>• All ranges: Replace oil pump or control valve body, then go to Step 7.</li> <li>• Any ranges: Replace ATX, then go to Step 7. (See 05-17-31 AUTOMATIC TRANSAXLE (ATX) REMOVAL/INSTALLATION.) (See ATX Workshop Manual FN4A-EL (9999-95-FN4A-99).)</li> </ul>
6	<b>CHECK OPERATION OF EACH VALVE AND EACH SPRING</b> <ul style="list-style-type: none"> <li>• Turn ignition key to OFF.</li> <li>• Remove control valve body.</li> <li>• Disassemble control valve body.</li> <li>• Is each valve operation okay and is return spring okay?</li> </ul> (See 05-17-36 CONTROL VALVE BODY REMOVAL/INSTALLATION.) (See ATX Workshop Manual FN4A-EL (9999-95-FN4A-99).)	Yes	Replace ATX, then go to next step (See ATX Workshop Manual FN4A-EL (9999-95-FN4A-99).)
		No	Repair or replace shift valve and return spring, then go to next step. (See 05-17-36 CONTROL VALVE BODY REMOVAL/INSTALLATION.) (See ATX Workshop Manual FN4A-EL (9999-95-FN4A-99).)
7	<b>VERIFY TROUBLESHOOTING OF DTC P0751 COMPLETED</b> <ul style="list-style-type: none"> <li>• Make sure to reconnect all disconnected connectors.</li> <li>• Clear DTC from memory using WDS or equivalent.</li> <li>• Start engine.</li> <li>• Warm up ATX.</li> <li>• Drive the vehicle under the following conditions and make sure that gears shift smoothly from 1GR to 4GR.               <ul style="list-style-type: none"> <li>— ATF temperature: <b>20 °C {68 °F} or above</b></li> <li>— Drive in D range</li> </ul> </li> <li>• Is pending code present?</li> </ul>	Yes	Replace PCM, then go to next step. (See 01-40A-7 PCM REMOVAL/INSTALLATION [ZM].) (See 01-40B-7 PCM REMOVAL/INSTALLATION [FS].)
		No	Go to next step.
8	<b>VERIFY AFTER REPAIR PROCEDURE</b> <ul style="list-style-type: none"> <li>• Perform "After Repair Procedure". (See 05-02-6 AFTER REPAIR PROCEDURE.)</li> <li>• Are any DTCs present?</li> </ul>	Yes	Go to applicable DTC inspection.
		No	Troubleshooting completed.

05-02

# ON-BOARD DIAGNOSTIC

DTC P0752

A3U050201030W20

<b>DTC P0752</b>	<b>Shift solenoid A stuck ON</b>
<b>DETECTION CONDITION</b>	<ul style="list-style-type: none"> <li>• When P0734 is not generated, and all conditions below satisfied in 1GR and 2GR.               <ul style="list-style-type: none"> <li>— ATF temperature <b>20 °C {68 °F} or above.</b></li> <li>— Engine run.</li> <li>— Either of P0705 or P0706 output, or D range is selected.</li> <li>— Brake pedal depressed.</li> <li>— Throttle opening angle closed throttle position.</li> <li>— Vehicle speed <b>0 km/h {0 mph}.</b></li> <li>— Input/turbine speed sensor signal <b>187.5 rpm or above.</b></li> <li>— Any of the following not generated: DTC P0500, P0705, P0706, P0710, P0715, P0751, P0752, P0753, P0756, P0757, P0758, P0761, P0762, P0763, P0766, P0767, P0768, P0771, P0772, P0773.</li> </ul> </li> </ul> <p><b>Diagnostic support note:</b></p> <ul style="list-style-type: none"> <li>• This is a continuous monitor (CCM).</li> <li>• MIL illuminates if PCM detects the above malfunction conditions during two consecutive drive cycles.</li> <li>• PENDING CODE is available.</li> <li>• FREEZE FRAME DATA is available.</li> <li>• O/D OFF indicator light flashes.</li> <li>• DTC is stored in the PCM memory.</li> </ul>
<b>POSSIBLE CAUSE</b>	<ul style="list-style-type: none"> <li>• ATF level low</li> <li>• Deteriorated ATF</li> <li>• Shift solenoid A stuck</li> <li>• Control valve stuck</li> <li>• PCM malfunction</li> </ul>

## Diagnostic procedure

STEP	INSPECTION		ACTION
1	<b>VERIFY FREEZE FRAME DATA HAS BEEN RECORDED</b> <ul style="list-style-type: none"> <li>• Has FREEZE FRAME PID DATA been recorded?</li> </ul>	Yes	Go to next step.
		No	Record FREEZE FRAME PID DATA on repair order, then go to next step.
2	<b>VERIFY RELATED REPAIR INFORMATION AVAILABILITY</b> <ul style="list-style-type: none"> <li>• Check for related Service Bulletins availability.</li> <li>• Is any related repair information available?</li> </ul>	Yes	Perform repair or diagnosis according to available repair information. <ul style="list-style-type: none"> <li>• If vehicle is not repaired, go to next step.</li> </ul>
		No	Go to next step.
3	<b>CHECK ATF CONDITION</b> <ul style="list-style-type: none"> <li>• Turn ignition key to OFF.</li> <li>• Check ATF condition.               <ul style="list-style-type: none"> <li>— Clear red: Normal</li> <li>— Milky: Water mixed in fluid</li> <li>— Reddish brown: Deteriorated ATF</li> </ul> </li> <li>• Is it okay?</li> </ul> (See 05–17–17 Automatic Transaxle Fluid (ATF) Condition Inspection.)	Yes	Go to next step.
		No	If ATF color milky or reddish brown, replace ATF, then go to Step 5. (See 05–17–18 AUTOMATIC TRANSAXLE FLUID (ATF) REPLACEMENT.)
4	<b>CHECK ATF LEVEL</b> <ul style="list-style-type: none"> <li>• Start engine.</li> <li>• Warm up ATX.</li> <li>• Is ATF level within specification?</li> </ul> (See 05–17–18 Automatic Transaxle Fluid (ATF) Level Inspection.)	Yes	Go to next step.
		No	Adjust ATF level, then go to Step 7. (See 05–17–18 Automatic Transaxle Fluid (ATF) Level Inspection.)
5	<b>INSPECT LINE PRESSURE</b> <ul style="list-style-type: none"> <li>• Start engine.</li> <li>• Measure line pressure.</li> </ul> <b>Specification</b> <b>FS engine</b> <b>Idle: 330—470 kPa {3.4—4.7 kgf/cm<sup>2</sup>, 49—66 psi}</b> <b>Stall: 1,160—1,320 kPa {11.9—13.4 kgf/cm<sup>2</sup>, 170—190 psi}</b> <b>ZM engine</b> <b>Idle: 330—470 kPa {3.4—4.7 kgf/cm<sup>2</sup>, 49—66 psi}</b> <b>Stall: 1,200—1,360 kPa {12.3—13.8 kgf/cm<sup>2</sup>, 175—196 psi}</b> <ul style="list-style-type: none"> <li>• Is line pressure within specification?</li> </ul> (See 05–17–12 Line Pressure Test.)	Yes	Go to next step.
		No	<ul style="list-style-type: none"> <li>• All ranges: Replace oil pump or control valve body, then go to Step 7.</li> <li>• Any ranges: Replace ATX, then go to Step 7. (See 05–17–31 AUTOMATIC TRANSAXLE (ATX) REMOVAL/INSTALLATION.) (See ATX Workshop Manual FN4A-EL (9999-95-FN4A-99).)</li> </ul>

## ON-BOARD DIAGNOSTIC

STEP	INSPECTION	ACTION	
6	<b>CHECK OPERATION OF EACH VALVE AND EACH SPRING</b> <ul style="list-style-type: none"> <li>• Turn ignition key to OFF.</li> <li>• Remove control valve body.</li> <li>• Disassemble control valve body.</li> <li>• Is each valve operation okay and is return spring okay?</li> </ul> (See 05-17-36 CONTROL VALVE BODY REMOVAL/INSTALLATION.) (See ATX Workshop Manual FN4A-EL (9999-95-FN4A-99).)	Yes	Replace ATX, then go to next step (See ATX Workshop Manual FN4A-EL (9999-95-FN4A-99).)
		No	Repair or replace shift valve and return spring, then go to next step. (See 05-17-36 CONTROL VALVE BODY REMOVAL/INSTALLATION.) (See ATX Workshop Manual FN4A-EL (9999-95-FN4A-99).)
7	<b>VERIFY TROUBLESHOOTING OF DTC P0752 COMPLETED</b> <ul style="list-style-type: none"> <li>• Make sure to reconnect all disconnected connectors.</li> <li>• Clear DTC from memory using WDS or equivalent.</li> <li>• Start engine.</li> <li>• Warm up ATX.</li> <li>• Drive the vehicle under the following conditions and make sure that gears shift smoothly from 1GR to 4GR.                             <ul style="list-style-type: none"> <li>— ATF temperature: <b>20 °C {68 °F} or above</b></li> <li>— Drive in D range</li> </ul> </li> <li>• Is pending code present?</li> </ul>	Yes	Replace PCM, then go to next step. (See 01-40A-7 PCM REMOVAL/INSTALLATION [ZM].) (See 01-40B-7 PCM REMOVAL/INSTALLATION [FS].)
		No	Go to next step.
8	<b>VERIFY AFTER REPAIR PROCEDURE</b> <ul style="list-style-type: none"> <li>• Perform "After Repair Procedure".</li> </ul> (See 05-02-6 AFTER REPAIR PROCEDURE.) <ul style="list-style-type: none"> <li>• Are any DTCs present?</li> </ul>	Yes	Go to applicable DTC inspection.
		No	Troubleshooting completed.

05-02

# ON-BOARD DIAGNOSTIC

**DTC P0753**

A3U050201030W21

<b>DTC P0753</b>	<b>Shift solenoid A malfunction (electrical)</b>
<b>DETECTION CONDITION</b>	<ul style="list-style-type: none"> <li>• If PCM detects either of following conditions, PCM determines that shift solenoid A circuit has a malfunction:                             <ul style="list-style-type: none"> <li>— Shift solenoid A voltage is stuck at <b>B+</b> after engine start.</li> <li>— Shift solenoid A voltage is stuck at <b>0 V</b> after engine start.</li> </ul> </li> </ul> <p><b>Diagnostic support note:</b></p> <ul style="list-style-type: none"> <li>• This is a continuous monitor (CCM).</li> <li>• MIL illuminates if PCM detects the above malfunction conditions during first drive cycle.</li> <li>• PENDING CODE is not available.</li> <li>• FREEZE FRAME DATA is available.</li> <li>• O/D OFF indicator light flashes.</li> <li>• DTC is stored in the PCM memory.</li> </ul>
<b>POSSIBLE CAUSE</b>	<ul style="list-style-type: none"> <li>• Shift solenoid A malfunction</li> <li>• Short to ground between ATX connector terminal A and PCM terminal 82</li> <li>• Short to power between ATX connector terminal A and PCM terminal 82</li> <li>• Open circuit between shift solenoid A terminal B and ATX connector terminal A</li> <li>• Open circuit between ATX connector terminal A and PCM terminal 82</li> <li>• Open circuit between shift solenoid A terminal A and body ground point</li> <li>• Damaged connector between shift solenoid A and PCM</li> <li>• PCM malfunction</li> </ul>

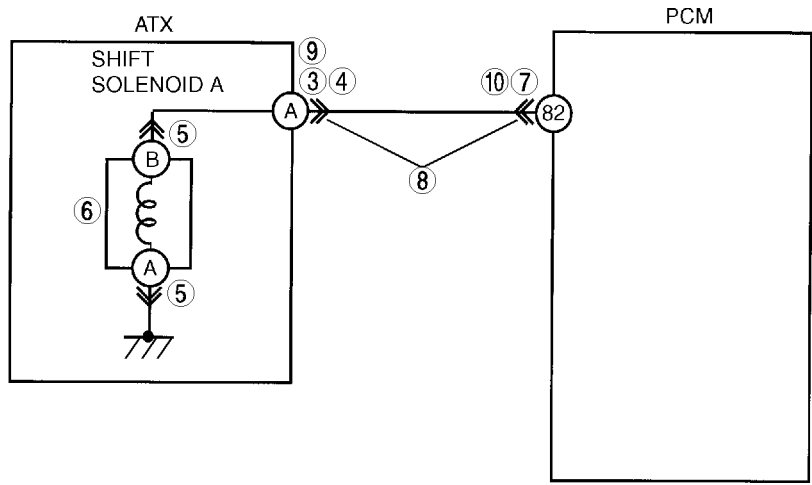

ATX CONNECTOR

SHIFT SOLENOID A



HARNESS SIDE CONNECTOR  
(VIEW FROM HARNESS SIDE)

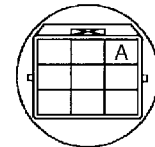

HARNESS SIDE CONNECTOR  
(VIEW FROM HARNESS SIDE)

PCM

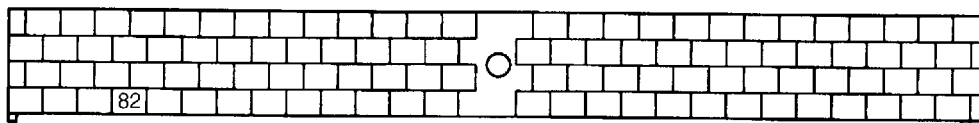

HARNESS SIDE CONNECTOR  
(VIEW FROM TERMINAL SIDE)

## ON-BOARD DIAGNOSTIC

### Diagnostic procedure

STEP	INSPECTION	ACTION	
1	<b>VERIFY FREEZE FRAME DATA HAS BEEN RECORDED</b> <ul style="list-style-type: none"> <li>Has FREEZE FRAME PID DATA been recorded?</li> </ul>	Yes	Go to next step.
		No	Record FREEZE FRAME PID DATA on repair order, then go to next step.
2	<b>VERIFY RELATED REPAIR INFORMATION AVAILABILITY</b> <ul style="list-style-type: none"> <li>Check for related Service Bulletins availability.</li> <li>Is any related repair information available?</li> </ul>	Yes	Perform repair or diagnosis according to available repair information. <ul style="list-style-type: none"> <li>If vehicle is not repaired, go to next step.</li> </ul>
		No	Go to next step.
3	<b>INSPECT ATX CONNECTOR FOR POOR CONNECTION</b> <ul style="list-style-type: none"> <li>Turn ignition key to OFF.</li> <li>Disconnect ATX connector.</li> <li>Check for poor connection (damaged/pulled-out terminals, corrosion, etc.).</li> <li>Is connection okay?</li> </ul>	Yes	Go to next step.
		No	Repair or replace connector and/or terminals, then go to Step 11.
4	<b>INSPECT RESISTANCE</b> <ul style="list-style-type: none"> <li>Check resistance between ATX connector terminal A (transaxle case side) and body ground.</li> <li>Is resistance <b>within 1.0—4.2 ohms</b>? (See 05-17-28 Inspection of Resistance (On-vehicle).)</li> </ul>	Yes	Go to Step 7.
		No	Go to next step.
5	<b>INSPECT SHIFT SOLENOID A CONNECTOR FOR POOR CONNECTION</b> <ul style="list-style-type: none"> <li>Disconnect shift solenoid A connector.</li> <li>Check for poor connection (damaged/pulled-out terminals, corrosion, etc.).</li> <li>Is connection okay?</li> </ul>	Yes	Go to next step.
		No	Repair or replace connector and/or terminal, then go to Step 11.
6	<b>INSPECT RESISTANCE</b> <ul style="list-style-type: none"> <li>Inspect resistance between shift solenoid A terminals A and B (part-side).</li> <li>Is resistance <b>within 1.0—4.2 ohms</b>? (See 05-17-29 Resistance Inspection (Off-vehicle).)</li> </ul>	Yes	Replace solenoid harness, then go to Step 11.
		No	Verify shift solenoid A installation. <ul style="list-style-type: none"> <li>If solenoid installed correctly, replace solenoid, then go to Step 11.</li> </ul> (See 05-17-30 SOLENOID VALVES REMOVAL/INSTALLATION.)
7	<b>INSPECT PCM CONNECTOR FOR POOR CONNECTION</b> <ul style="list-style-type: none"> <li>Disconnect PCM connector.</li> <li>Check for poor connection (damaged/pulled-out terminals, corrosion, etc.).</li> <li>Is connection okay?</li> </ul>	Yes	Go to next step.
		No	Repair or replace connector and/or terminals, then go to Step 11.
8	<b>INSPECT ATX CONNECTOR CIRCUIT FOR OPEN</b> <ul style="list-style-type: none"> <li>Inspect for continuity between PCM terminal 82 (harness-side) and ATX connector terminal A (vehicle harness-side).</li> <li>Is there continuity between terminals?</li> </ul>	Yes	Go to next step.
		No	Repair or replace harness, then go to Step 11.
9	<b>INSPECT ATX CONNECTOR CIRCUIT FOR SHORT TO POWER</b> <ul style="list-style-type: none"> <li>Turn ignition key to ON (engine OFF).</li> <li>Inspect voltage at ATX connector terminal A (vehicle harness-side).</li> <li>Is voltage <b>0 V</b>?</li> </ul>	Yes	Go to next step.
		No	Repair or replace harness, then go to Step 11.
10	<b>INSPECT PCM CIRCUIT FOR SHORT TO GROUND</b> <ul style="list-style-type: none"> <li>Turn ignition key to OFF.</li> <li>Inspect for continuity between PCM terminal 82 (harness-side) and body ground.</li> <li>Is there continuity?</li> </ul>	Yes	Repair or replace harness, then go to Step 11.
		No	Go to next step.

05-02

## ON-BOARD DIAGNOSTIC

STEP	INSPECTION	ACTION	
11	<b>VERIFY TROUBLESHOOTING OF DTC P0753 COMPLETED</b> <ul style="list-style-type: none"> <li>• Make sure to reconnect all disconnected connectors.</li> <li>• Clear DTC from memory using WDS or equivalent.</li> <li>• Drive vehicle in D range and make sure that gears shift smoothly from 1GR to 4GR.</li> <li>• Are any DTCs present?</li> </ul>	Yes	Replace PCM, then go to next step. (See 01-40A-7 PCM REMOVAL/INSTALLATION [ZM].) (See 01-40B-7 PCM REMOVAL/INSTALLATION [FS].)
		No	No concern is detected. Go to next step.
12	<b>VERIFY AFTER REPAIR PROCEDURE</b> <ul style="list-style-type: none"> <li>• Perform "After Repair Procedure". (See 05-02-6 AFTER REPAIR PROCEDURE.)</li> <li>• Are any DTCs present?</li> </ul>	Yes	Go to applicable DTC inspection.
		No	Troubleshooting completed.

### DTC P0756

A3U050201030W22

DTC P0756	Shift solenoid B stuck OFF
<b>DETECTION CONDITION</b>	<ul style="list-style-type: none"> <li>• When any of DTC P0732, P0733, and P0734 are not generated, and all conditions below satisfied. <ul style="list-style-type: none"> <li>— ATF temperature <b>20 °C {68 °F} or above.</b></li> <li>— Driving in 1GR at D range.</li> <li>— Engine run.</li> <li>— Turbine speed <b>within 225—4,988 rpm.</b></li> <li>— Differential gear case (output) revolution speed <b>35 rpm or above</b></li> <li>— Throttle opening angle (TP PID) <b>3.13% or above</b> (FS engine).</li> <li>— Throttle opening angle (TP PID) <b>3.91% or above</b> (ZM engine).</li> <li>— Revolution ratio of forward clutch drum revolution to differential gear case revolution <b>below 2.157.</b></li> <li>— Any of the following not generated: DTC P0500, P0705, P0706, P0710, P0715, P0751, P0752, P0753, P0756, P0757, P0758, P0761, P0762, P0763, P0766, P0767, P0768, P0771, P0772, P0773.</li> </ul> </li> </ul> <p><b>Diagnostic support note:</b></p> <ul style="list-style-type: none"> <li>• This is a continuous monitor (CCM).</li> <li>• MIL illuminates if PCM detects the above malfunction conditions during two consecutive drive cycles.</li> <li>• PENDING CODE is available.</li> <li>• FREEZE FRAME DATA is available.</li> <li>• O/D OFF indicator light flashes.</li> <li>• DTC is stored in the PCM memory.</li> </ul>
<b>POSSIBLE CAUSE</b>	<ul style="list-style-type: none"> <li>• ATF level low</li> <li>• Deteriorated ATF</li> <li>• Shift solenoid B stuck</li> <li>• Control valve stuck</li> <li>• PCM malfunction</li> </ul>

### Diagnostic procedure

STEP	INSPECTION	ACTION	
1	<b>VERIFY FREEZE FRAME DATA HAS BEEN RECORDED</b> <ul style="list-style-type: none"> <li>• Has FREEZE FRAME PID DATA been recorded?</li> </ul>	Yes	Go to next step.
		No	Record FREEZE FRAME PID DATA on repair order, then go to next step.
2	<b>VERIFY RELATED REPAIR INFORMATION AVAILABILITY</b> <ul style="list-style-type: none"> <li>• Check for related Service Bulletins availability.</li> <li>• Is any related repair information available?</li> </ul>	Yes	Perform repair or diagnosis according to available repair information. <ul style="list-style-type: none"> <li>• If vehicle is not repaired, go to next step.</li> </ul>
		No	Go to next step.
3	<b>CHECK ATF CONDITION</b> <ul style="list-style-type: none"> <li>• Turn ignition key to OFF.</li> <li>• Check ATF condition. <ul style="list-style-type: none"> <li>— Clear red: Normal</li> <li>— Milky: Water mixed in fluid</li> <li>— Reddish brown: Deteriorated ATF</li> </ul> </li> <li>• Is it okay?</li> </ul> (See 05-17-17 Automatic Transaxle Fluid (ATF) Condition Inspection.)	Yes	Go to next step.
		No	If ATF color milky or reddish brown, replace ATF, then go to Step 5. (See 05-17-18 AUTOMATIC TRANSAXLE FLUID (ATF) REPLACEMENT.)
4	<b>CHECK ATF LEVEL</b> <ul style="list-style-type: none"> <li>• Start engine.</li> <li>• Warm up ATX.</li> <li>• Is ATF level within specification?</li> </ul> (See 05-17-18 Automatic Transaxle Fluid (ATF) Level Inspection.)	Yes	Go to next step.
		No	Adjust ATF level, then go to Step 7. (See 05-17-18 Automatic Transaxle Fluid (ATF) Level Inspection.)



## ON-BOARD DIAGNOSTIC

STEP	INSPECTION	ACTION	
5	<b>INSPECT LINE PRESSURE</b> <ul style="list-style-type: none"> <li>• Start engine.</li> <li>• Measure line pressure.</li> </ul> <b>Specification</b> <b>FS engine</b> <b>Idle: 330—470 kPa {3.4—4.7 kgf/cm<sup>2</sup>, 49—66 psi}</b> <b>Stall: 1,160—1,320 kPa {11.9—13.4 kgf/cm<sup>2</sup>, 170—190 psi}</b> <b>ZM engine</b> <b>Idle: 330—470 kPa {3.4—4.7 kgf/cm<sup>2</sup>, 49—66 psi}</b> <b>Stall: 1,200—1,360 kPa {12.3—13.8 kgf/cm<sup>2</sup>, 175—196 psi}</b> <ul style="list-style-type: none"> <li>• Is line pressure within specification? (See 05-17-12 Line Pressure Test.)</li> </ul>	Yes	Go to next step.
		No	<ul style="list-style-type: none"> <li>• All ranges: Replace oil pump or control valve body, then go to Step 7.</li> <li>• Any ranges: Replace ATX, then go to Step 7. (See 05-17-31 AUTOMATIC TRANSAXLE (ATX) REMOVAL/INSTALLATION.) (See ATX Workshop Manual FN4A-EL (9999-95-FN4A-99).)</li> </ul>
6	<b>CHECK OPERATION OF EACH VALVE AND EACH SPRING</b> <ul style="list-style-type: none"> <li>• Turn ignition key to OFF.</li> <li>• Remove control valve body.</li> <li>• Disassemble control valve body.</li> <li>• Is each valve operation okay and is return spring okay? (See 05-17-36 CONTROL VALVE BODY REMOVAL/INSTALLATION.) (See ATX Workshop Manual FN4A-EL (9999-95-FN4A-99).)</li> </ul>	Yes	Replace ATX, then go to next step (See ATX Workshop Manual FN4A-EL (9999-95-FN4A-99).)
		No	Repair or replace shift valve and return spring, then go to next step. (See 05-17-36 CONTROL VALVE BODY REMOVAL/INSTALLATION.) (See ATX Workshop Manual FN4A-EL (9999-95-FN4A-99).)
7	<b>VERIFY TROUBLESHOOTING OF DTC P0756 COMPLETED</b> <ul style="list-style-type: none"> <li>• Make sure to reconnect all disconnected connectors.</li> <li>• Clear DTC from memory using WDS or equivalent.</li> <li>• Start engine.</li> <li>• Warm up ATX.</li> <li>• Drive the vehicle under the following conditions and make sure that gears shift smoothly from 1GR to 4GR. <ul style="list-style-type: none"> <li>— ATF temperature: <b>20 °C {68 °F} or above</b></li> <li>— Drive in D range</li> <li>— Engine speed: <b>450 rpm or above</b> (RPM PID)</li> <li>— Throttle opening angle (TP PID): <b>3.13% or above</b> (FS engine)</li> <li>— Throttle opening angle (TP PID): <b>3.91% or above</b> (ZM engine)</li> </ul> </li> <li>• Is pending code present?</li> </ul>	Yes	Replace PCM, then go to next step. (See 01-40A-7 PCM REMOVAL/INSTALLATION [ZM].) (See 01-40B-7 PCM REMOVAL/INSTALLATION [FS].)
		No	Go to next step.
8	<b>VERIFY AFTER REPAIR PROCEDURE</b> <ul style="list-style-type: none"> <li>• Perform "After Repair Procedure". (See 05-02-6 AFTER REPAIR PROCEDURE.)</li> <li>• Are any DTCs present?</li> </ul>	Yes	Go to applicable DTC inspection.
		No	Troubleshooting completed.

05-02

# ON-BOARD DIAGNOSTIC

**DTC P0757**

A3U050201030W23

DTC P0757	Shift solenoid B stuck ON
<b>DETECTION CONDITION</b>	<ul style="list-style-type: none"> <li>• When either of DTC P0731 and P0733 are not generated, and both the following conditions are satisfied.                             <ul style="list-style-type: none"> <li>— When all conditions below satisfied while driving in 2GR.                                     <ul style="list-style-type: none"> <li>• ATF temperature <b>20 °C {68 °F} or above.</b></li> <li>• Driving in D range.</li> <li>• Engine run.</li> <li>• Turbine speed <b>within 225—4,988 rpm.</b></li> <li>• Differential gear case (output) revolution speed <b>35 rpm or above.</b></li> <li>• Revolution ratio of forward clutch drum revolution to differential gear case revolution <b>below 1.249 or more than 2.157.</b></li> </ul> </li> <li>• Any of the following not generated: DTC P0500, P0705, P0706, P0710, P0715, P0751, P0752, P0753, P0756, P0757, P0758, P0761, P0762, P0763, P0766, P0767, P0768, P0771, P0772, P0773.</li> </ul> </li> <li>— When all conditions below satisfied with driving in 4GR.                                     <ul style="list-style-type: none"> <li>• ATF temperature <b>20 °C {68 °F} or above.</b></li> <li>• Driving in D range.</li> <li>• Engine run.</li> <li>• Turbine speed <b>within 225—4,988 rpm.</b></li> <li>• Differential gear case (output) revolution speed <b>35 rpm or above.</b></li> <li>• Vehicle speed <b>50 km/h {31 mph}.</b></li> <li>• Throttle opening angle closed throttle position.</li> <li>• Revolution ratio of forward clutch drum revolution to differential gear case revolution <b>below 0.6 or 1.249 or above.</b></li> <li>• Any of the following not generated: DTC P0500, P0705, P0706, P0710, P0715, P0751, P0752, P0753, P0756, P0757, P0758, P0761, P0762, P0763, P0766, P0767, P0768, P0771, P0772, P0773.</li> </ul> </li> </ul> <p><b>Diagnostic support note:</b></p> <ul style="list-style-type: none"> <li>• This is a continuous monitor (CCM).</li> <li>• MIL illuminates if PCM detects the above malfunction conditions during two consecutive drive cycles.</li> <li>• PENDING CODE is available.</li> <li>• FREEZE FRAME DATA is available.</li> <li>• O/D OFF indicator light flashes.</li> <li>• DTC is stored in the PCM memory.</li> </ul>
<b>POSSIBLE CAUSE</b>	<ul style="list-style-type: none"> <li>• ATF level low</li> <li>• Deteriorated ATF</li> <li>• Shift solenoid B stuck</li> <li>• Control valve stuck</li> <li>• PCM malfunction</li> </ul>

**Diagnostic procedure**

STEP	INSPECTION		ACTION
1	<b>VERIFY FREEZE FRAME DATA HAS BEEN RECORDED</b> <ul style="list-style-type: none"> <li>• Has FREEZE FRAME PID DATA been recorded?</li> </ul>	Yes	Go to next step.
		No	Record FREEZE FRAME PID DATA on repair order, then go to next step.
2	<b>VERIFY RELATED REPAIR INFORMATION AVAILABILITY</b> <ul style="list-style-type: none"> <li>• Check for related Service Bulletins availability.</li> <li>• Is any related repair information available?</li> </ul>	Yes	Perform repair or diagnosis according to available repair information. <ul style="list-style-type: none"> <li>• If vehicle is not repaired, go to next step.</li> </ul>
		No	Go to next step.
3	<b>CHECK ATF CONDITION</b> <ul style="list-style-type: none"> <li>• Turn ignition key to OFF.</li> <li>• Check ATF condition.                                     <ul style="list-style-type: none"> <li>— Clear red: Normal</li> <li>— Milky: Water mixed in fluid</li> <li>— Reddish brown: Deteriorated ATF</li> </ul> </li> <li>• Is it okay?</li> </ul> (See 05–17–17 Automatic Transaxle Fluid (ATF) Condition Inspection.)	Yes	Go to next step.
		No	If ATF color milky or reddish brown, replace ATF, then go to Step 5. (See 05–17–18 AUTOMATIC TRANSAXLE FLUID (ATF) REPLACEMENT.)
4	<b>CHECK ATF LEVEL</b> <ul style="list-style-type: none"> <li>• Start engine.</li> <li>• Warm up ATX.</li> <li>• Is ATF level within specification?</li> </ul> (See 05–17–18 Automatic Transaxle Fluid (ATF) Level Inspection.)	Yes	Go to next step.
		No	Adjust ATF level, then go to Step 7. (See 05–17–18 Automatic Transaxle Fluid (ATF) Level Inspection.)

## ON-BOARD DIAGNOSTIC

STEP	INSPECTION	ACTION	
5	<b>INSPECT LINE PRESSURE</b> <ul style="list-style-type: none"> <li>• Start engine.</li> <li>• Measure line pressure.</li> </ul> <b>Specification</b> <b>FS engine</b> <b>Idle: 330—470 kPa {3.4—4.7 kgf/cm<sup>2</sup>, 49—66 psi}</b> <b>Stall: 1,160—1,320 kPa {11.9—13.4 kgf/cm<sup>2</sup>, 170—190 psi}</b> <b>ZM engine</b> <b>Idle: 330—470 kPa {3.4—4.7 kgf/cm<sup>2</sup>, 49—66 psi}</b> <b>Stall: 1,200—1,360 kPa {12.3—13.8 kgf/cm<sup>2</sup>, 175—196 psi}</b> <ul style="list-style-type: none"> <li>• Is line pressure within specification? (See 05-17-12 Line Pressure Test.)</li> </ul>	Yes	Go to next step.
		No	<ul style="list-style-type: none"> <li>• All ranges: Replace oil pump or control valve body, then go to Step 7.</li> <li>• Any ranges: Replace ATX, then go to Step 7. (See 05-17-31 AUTOMATIC TRANSAXLE (ATX) REMOVAL/INSTALLATION.) (See ATX Workshop Manual FN4A-EL (9999-95-FN4A-99).)</li> </ul>
6	<b>CHECK OPERATION OF EACH VALVE AND EACH SPRING</b> <ul style="list-style-type: none"> <li>• Turn ignition key to OFF.</li> <li>• Remove control valve body.</li> <li>• Disassemble control valve body.</li> <li>• Is each valve operation okay and is return spring okay? (See 05-17-36 CONTROL VALVE BODY REMOVAL/INSTALLATION.) (See ATX Workshop Manual FN4A-EL (9999-95-FN4A-99).)</li> </ul>	Yes	Replace ATX, then go to next step (See ATX Workshop Manual FN4A-EL (9999-95-FN4A-99).)
		No	Repair or replace shift valve and return spring, then go to next step. (See 05-17-36 CONTROL VALVE BODY REMOVAL/INSTALLATION.) (See ATX Workshop Manual FN4A-EL (9999-95-FN4A-99).)
7	<b>VERIFY TROUBLESHOOTING OF DTC P0757 COMPLETED</b> <ul style="list-style-type: none"> <li>• Make sure to reconnect all disconnected connectors.</li> <li>• Clear DTC from memory using WDS or equivalent.</li> <li>• Start engine.</li> <li>• Warm up ATX.</li> <li>• Drive the vehicle under the following conditions make sure that gears shift smoothly from 1GR to 4GR. <ul style="list-style-type: none"> <li>— ATF temperature: <b>20 °C {68 °F} or above</b></li> <li>— Drive in D range</li> <li>— Engine speed: <b>450 rpm or above</b> (RPM PID)</li> <li>— Throttle opening angle (TP PID): <b>0%</b> (4th gear only)</li> <li>— Vehicle speed (VSS PID): <b>50 km/h {31 mph}</b> (4th gear only)</li> </ul> </li> <li>• Is pending code present?</li> </ul>	Yes	Replace PCM, then go to next step. (See 01-40A-7 PCM REMOVAL/INSTALLATION [ZM].) (See 01-40B-7 PCM REMOVAL/INSTALLATION [FS].)
		No	Go to next step.
8	<b>VERIFY AFTER REPAIR PROCEDURE</b> <ul style="list-style-type: none"> <li>• Perform "After Repair Procedure". (See 05-02-6 AFTER REPAIR PROCEDURE.)</li> <li>• Are any DTCs present?</li> </ul>	Yes	Go to applicable DTC inspection.
		No	Troubleshooting completed.

05-02

# ON-BOARD DIAGNOSTIC

**DTC P0758**

A3U050201030W24

<b>DTC P0758</b>	<b>Shift solenoid B malfunction (electrical)</b>
<b>DETECTION CONDITION</b>	<ul style="list-style-type: none"> <li>• If PCM detects either of following conditions, PCM determines that shift solenoid B circuit has a malfunction:                             <ul style="list-style-type: none"> <li>— Shift solenoid B voltage is stuck at <b>B+</b> after engine start.</li> <li>— Shift solenoid B voltage is stuck at <b>0 V</b> after engine start.</li> </ul> </li> </ul> <p><b>Diagnostic support note:</b></p> <ul style="list-style-type: none"> <li>• This is a continuous monitor (CCM).</li> <li>• MIL illuminates if PCM detects the above malfunction conditions during first drive cycle.</li> <li>• PENDING CODE is not available.</li> <li>• FREEZE FRAME DATA is available.</li> <li>• O/D OFF indicator light flashes.</li> <li>• DTC is stored in the PCM memory.</li> </ul>
<b>POSSIBLE CAUSE</b>	<ul style="list-style-type: none"> <li>• Shift solenoid B malfunction</li> <li>• Short to ground between ATX connector terminal C and PCM terminal 99</li> <li>• Short to power between ATX connector terminal C and PCM terminal 99</li> <li>• Open circuit between shift solenoid B terminal B and ATX connector terminal C</li> <li>• Open circuit between ATX connector terminal C and PCM terminal 99</li> <li>• Open circuit between shift solenoid B terminal A and body ground point</li> <li>• Damaged connector between shift solenoid B and PCM</li> <li>• PCM malfunction</li> </ul>

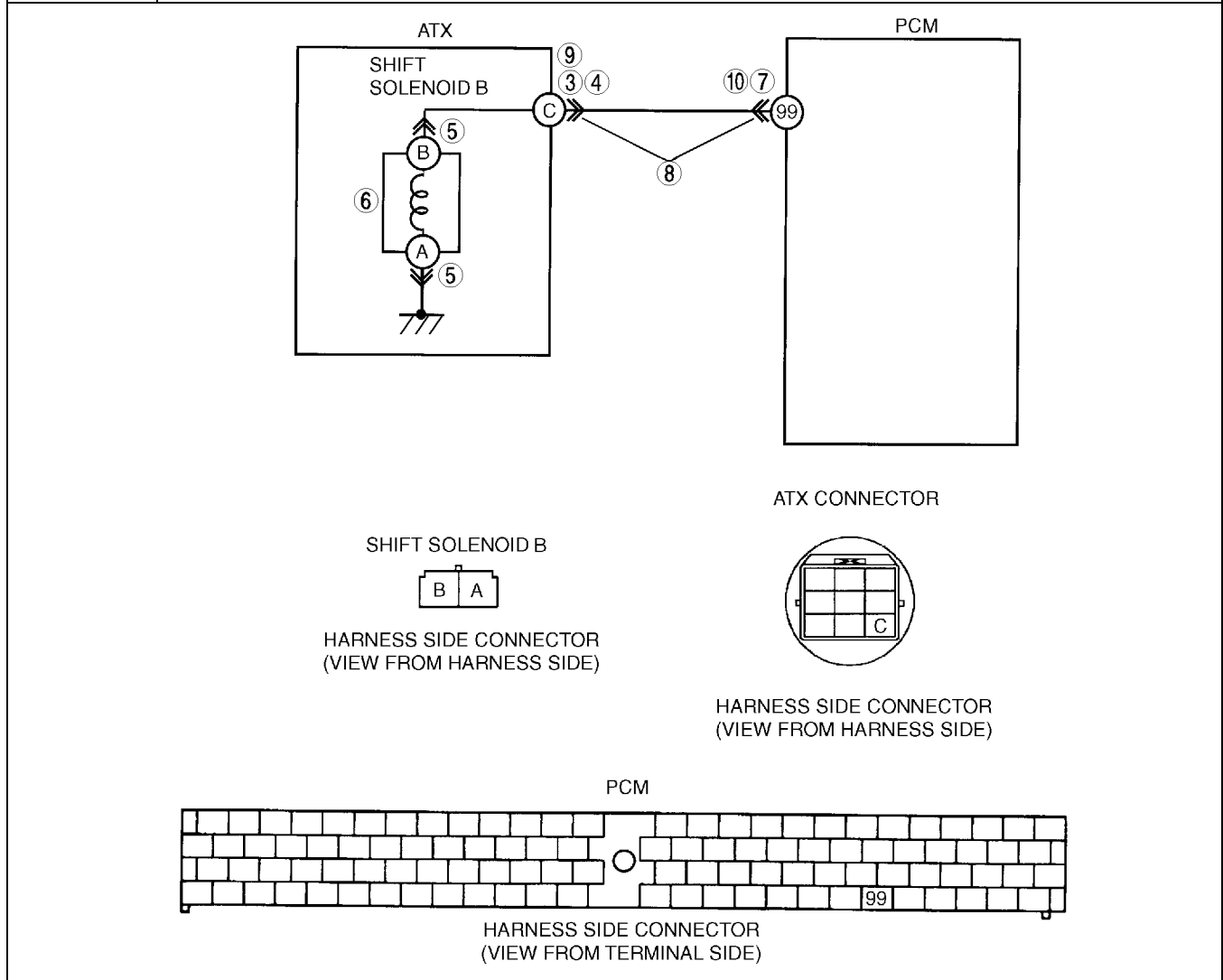

**Diagnostic procedure**

STEP	INSPECTION		ACTION
1	<b>VERIFY FREEZE FRAME DATA HAS BEEN RECORDED</b> <ul style="list-style-type: none"> <li>• Has FREEZE FRAME PID DATA been recorded?</li> </ul>	Yes	Go to next step.
		No	Record FREEZE FRAME PID DATA on repair order, then go to next step.

## ON-BOARD DIAGNOSTIC

STEP	INSPECTION	ACTION	
2	<b>VERIFY RELATED REPAIR INFORMATION AVAILABILITY</b> <ul style="list-style-type: none"> <li>Check for related Service Bulletins availability.</li> <li>Is any related repair information available?</li> </ul>	Yes	Perform repair or diagnosis according to available repair information. <ul style="list-style-type: none"> <li>If vehicle is not repaired, go to next step.</li> </ul>
		No	Go to next step.
3	<b>INSPECT ATX CONNECTOR FOR POOR CONNECTION</b> <ul style="list-style-type: none"> <li>Turn ignition key to OFF.</li> <li>Disconnect ATX connector.</li> <li>Check for poor connection (damaged/pulled-out terminals, corrosion, etc.).</li> <li>Is connection okay?</li> </ul>	Yes	Go to next step.
		No	Repair or replace connector and/or terminals, then go to Step 11.
4	<b>INSPECT RESISTANCE</b> <ul style="list-style-type: none"> <li>Inspect resistance between ATX connector terminal C (transaxle case side) and body ground.</li> <li>Is resistance <b>within 1.0—4.2 ohms</b>? (See 05-17-28 Inspection of Resistance (On-vehicle).)</li> </ul>	Yes	Go to Step 7.
		No	Go to next step.
5	<b>INSPECT SHIFT SOLENOID B CONNECTOR FOR POOR CONNECTION</b> <ul style="list-style-type: none"> <li>Disconnect shift solenoid B connector.</li> <li>Check for poor connection (damaged/pulled-out terminals, corrosion, etc.).</li> <li>Is connection okay?</li> </ul>	Yes	Go to next step.
		No	Repair or replace connector and/or terminal, then go to Step 11.
6	<b>INSPECT RESISTANCE</b> <ul style="list-style-type: none"> <li>Inspect resistance between shift solenoid B terminals A and B (part-side).</li> <li>Is resistance <b>within 1.0—4.2 ohms</b>? (See 05-17-29 Resistance Inspection (Off-vehicle).)</li> </ul>	Yes	Replace solenoid harness, then go to Step 11.
		No	Verify shift solenoid B installation. <ul style="list-style-type: none"> <li>If solenoid installed correctly, replace solenoid, then go to Step 11.</li> </ul> (See 05-17-30 SOLENOID VALVES REMOVAL/INSTALLATION.)
7	<b>INSPECT PCM CONNECTOR FOR POOR CONNECTION</b> <ul style="list-style-type: none"> <li>Disconnect PCM connector.</li> <li>Check for poor connection (damaged/pulled-out terminals, corrosion, etc.).</li> <li>Is connection okay?</li> </ul>	Yes	Go to next step.
		No	Repair or replace connector and/or terminals, then go to Step 11.
8	<b>INSPECT ATX CONNECTOR CIRCUIT FOR OPEN</b> <ul style="list-style-type: none"> <li>Inspect for continuity between PCM terminal 99 (harness-side) and ATX connector terminal C (vehicle harness-side).</li> <li>Is there continuity between terminals?</li> </ul>	Yes	Go to next step.
		No	Repair or replace harness, then go to Step 11.
9	<b>INSPECT ATX CONNECTOR CIRCUIT FOR SHORT TO POWER</b> <ul style="list-style-type: none"> <li>Turn ignition key to ON (engine OFF).</li> <li>Check for voltage at ATX connector terminal C (vehicle harness-side).</li> <li>Is voltage <b>0 V</b>?</li> </ul>	Yes	Go to next step.
		No	Repair or replace harness, then go to Step 11.
10	<b>INSPECT PCM CIRCUIT FOR SHORT TO GROUND</b> <ul style="list-style-type: none"> <li>Turn ignition key to OFF.</li> <li>Check for continuity between PCM terminal 99 (harness-side) and body ground.</li> <li>Is there continuity?</li> </ul>	Yes	Repair or replace harness, then go to Step 11.
		No	Go to next step.
11	<b>VERIFY TROUBLESHOOTING OF DTC P0758 SHIFT SOLENOID B COMPLETED</b> <ul style="list-style-type: none"> <li>Make sure to reconnect all disconnected connectors.</li> <li>Clear DTC from memory using WDS or equivalent.</li> <li>Drive vehicle in D range and make sure that gears shift smoothly from 1GR to 4GR.</li> <li>Are any DTCs present?</li> </ul>	Yes	Replace PCM, then go to next step. (See 01-40A-7 PCM REMOVAL/INSTALLATION [ZM].) (See 01-40B-7 PCM REMOVAL/INSTALLATION [FS].)
		No	Go to next step.
12	<b>VERIFY AFTER REPAIR PROCEDURE</b> <ul style="list-style-type: none"> <li>Perform "After Repair Procedure". (See 05-02-6 AFTER REPAIR PROCEDURE.)</li> <li>Are any DTCs present?</li> </ul>	Yes	Go to applicable DTC inspection.
		No	Troubleshooting completed.

05-02

# ON-BOARD DIAGNOSTIC

DTC P0761

A3U050201030W25

DTC P0761	Shift solenoid C stuck OFF
<b>DETECTION CONDITION</b>	<ul style="list-style-type: none"> <li>• When either of DTC P0733 and P0734 are not generated, and both the following conditions are satisfied.                             <ul style="list-style-type: none"> <li>— When all conditions below satisfied while driving in 1GR.                                     <ul style="list-style-type: none"> <li>• ATF temperature <b>20 °C {68 °F} or above.</b></li> <li>• Driving in D range.</li> <li>• Engine run.</li> <li>• Turbine speed <b>within 225—4,988 rpm.</b></li> <li>• Throttle opening angle (<b>TP PID</b>) <b>3.13% or above</b> (FS engine).</li> <li>• Throttle opening angle (<b>TP PID</b>) <b>3.91% or above</b> (ZM engine).</li> <li>• Differential gear case (output) revolution speed <b>35 rpm or above.</b></li> <li>• Revolution ratio of forward clutch drum revolution to differential gear case revolution <b>below 2.157.</b></li> <li>• Any of DTC P0500, P0705, P0706, P0710, P0715, P0751, P0752, P0753, P0756, P0757, P0758, P0761, P0762, P0763, P0766, P0767, P0768, P0771, P0772, P0773 not output.</li> </ul> </li> <li>— When all conditions below satisfied while driving in 2GR.                                     <ul style="list-style-type: none"> <li>• ATF temperature <b>20 °C {68 °F} or above.</b></li> <li>• Driving in D range.</li> <li>• Engine run.</li> <li>• Turbine speed <b>within 225—4,988 rpm.</b></li> <li>• Differential gear case (output) revolution speed <b>35 rpm or above.</b></li> <li>• Revolution ratio of forward clutch drum revolution to differential gear case revolution <b>below 1.249 or 2.157 or above.</b></li> <li>• Any of the following not generated: DTC P0500, P0705, P0706, P0710, P0715, P0751, P0752, P0753, P0756, P0757, P0758, P0761, P0762, P0763, P0766, P0767, P0768, P0771, P0772, P0773.</li> </ul> </li> </ul> </li> </ul> <p><b>Diagnostic support note:</b></p> <ul style="list-style-type: none"> <li>• This is a continuous monitor (CCM).</li> <li>• MIL illuminates if PCM detects the above malfunction conditions during two consecutive drive cycles.</li> <li>• PENDING CODE is available.</li> <li>• FREEZE FRAME DATA is available.</li> <li>• O/D OFF indicator light flashes.</li> <li>• DTC is stored in the PCM memory.</li> </ul>
<b>POSSIBLE CAUSE</b>	<ul style="list-style-type: none"> <li>• ATF level low</li> <li>• Deteriorated ATF</li> <li>• Shift solenoid C stuck</li> <li>• Control valve stuck</li> <li>• PCM malfunction</li> </ul>

## Diagnostic procedure

STEP	INSPECTION		ACTION
1	<b>VERIFY FREEZE FRAME DATA HAS BEEN RECORDED</b> <ul style="list-style-type: none"> <li>• Has FREEZE FRAME PID DATA been recorded?</li> </ul>	Yes	Go to next step.
		No	Record FREEZE FRAME PID DATA on repair order, then go to next step.
2	<b>VERIFY RELATED REPAIR INFORMATION AVAILABILITY</b> <ul style="list-style-type: none"> <li>• Check for related Service Bulletins availability.</li> <li>• Is any related repair information available?</li> </ul>	Yes	Perform repair or diagnosis according to available repair information. <ul style="list-style-type: none"> <li>• If vehicle is not repaired, go to next step.</li> </ul>
		No	Go to next step.
3	<b>CHECK ATF CONDITION</b> <ul style="list-style-type: none"> <li>• Turn ignition key to OFF.</li> <li>• Check ATF condition.                                     <ul style="list-style-type: none"> <li>— Clear red: Normal</li> <li>— Milky: Water mixed in fluid</li> <li>— Reddish brown: Deteriorated ATF</li> </ul> </li> <li>• Is it okay?</li> </ul> (See 05–17–17 Automatic Transaxle Fluid (ATF) Condition Inspection.)	Yes	Go to next step.
		No	If ATF color milky or reddish brown, replace ATF, then go to Step 5. (See 05–17–18 AUTOMATIC TRANSAXLE FLUID (ATF) REPLACEMENT.)
4	<b>CHECK ATF LEVEL</b> <ul style="list-style-type: none"> <li>• Start engine.</li> <li>• Warm up ATX.</li> <li>• Is ATF level within specification?</li> </ul> (See 05–17–18 Automatic Transaxle Fluid (ATF) Level Inspection.)	Yes	Go to next step.
		No	Adjust ATF level, then go to Step 7. (See 05–17–18 Automatic Transaxle Fluid (ATF) Level Inspection.)

## ON-BOARD DIAGNOSTIC

STEP	INSPECTION	ACTION	
5	<b>INSPECT LINE PRESSURE</b> <ul style="list-style-type: none"> <li>• Start engine.</li> <li>• Measure line pressure.</li> </ul> <b>Specification</b> <b>FS engine</b> <b>Idle: 330—470 kPa {3.4—4.7 kgf/cm<sup>2</sup>, 49—66 psi}</b> <b>Stall: 1,160—1,320 kPa {11.9—13.4 kgf/cm<sup>2</sup>, 170—190 psi}</b> <b>ZM engine</b> <b>Idle: 330—470 kPa {3.4—4.7 kgf/cm<sup>2</sup>, 49—66 psi}</b> <b>Stall: 1,200—1,360 kPa {12.3—13.8 kgf/cm<sup>2</sup>, 175—196 psi}</b> <ul style="list-style-type: none"> <li>• Is line pressure within specification? (See 05-17-12 Line Pressure Test.)</li> </ul>	Yes	Go to next step.
		No	<ul style="list-style-type: none"> <li>• All ranges: Replace oil pump or control valve body, then go to Step 7.</li> <li>• Any ranges: Replace ATX, then go to Step 7. (See 05-17-31 AUTOMATIC TRANSAXLE (ATX) REMOVAL/INSTALLATION.) (See ATX Workshop Manual FN4A-EL (9999-95-FN4A-99).)</li> </ul>
6	<b>CHECK OPERATION OF EACH VALVE AND EACH SPRING</b> <ul style="list-style-type: none"> <li>• Turn ignition key to OFF.</li> <li>• Remove control valve body.</li> <li>• Disassemble control valve body.</li> <li>• Is each valve operation okay and is return spring okay? (See 05-17-36 CONTROL VALVE BODY REMOVAL/INSTALLATION.) (See ATX Workshop Manual FN4A-EL (9999-95-FN4A-99).)</li> </ul>	Yes	Replace ATX, then go to next step (See ATX Workshop Manual FN4A-EL (9999-95-FN4A-99).)
		No	Repair or replace shift valve and return spring, then go to next step. (See 05-17-36 CONTROL VALVE BODY REMOVAL/INSTALLATION.) (See ATX Workshop Manual FN4A-EL (9999-95-FN4A-99).)
7	<b>VERIFY TROUBLESHOOTING OF DTC P0761 COMPLETED</b> <ul style="list-style-type: none"> <li>• Make sure to reconnect all disconnected connectors.</li> <li>• Clear DTC from memory using WDS or equivalent.</li> <li>• Start engine.</li> <li>• Warm up ATX.</li> <li>• Drive the vehicle under the following conditions and make sure that gears shift smoothly from 1GR to 4GR.                             <ul style="list-style-type: none"> <li>— ATF temperature: <b>20 °C {68 °F} or above</b></li> <li>— Drive in D range</li> <li>— Throttle opening angle (TP PID): <b>3.13% or above</b> (FS engine)</li> <li>— Throttle opening angle (TP PID): <b>3.91% or above</b> (ZM engine) (TP PID)</li> </ul> </li> <li>• Is pending code present?</li> </ul>	Yes	Replace PCM, then go to next step. (See 01-40A-7 PCM REMOVAL/INSTALLATION [ZM].) (See 01-40B-7 PCM REMOVAL/INSTALLATION [FS].)
		No	Go to next step.
8	<b>VERIFY AFTER REPAIR PROCEDURE</b> <ul style="list-style-type: none"> <li>• Perform "After Repair Procedure". (See 05-02-6 AFTER REPAIR PROCEDURE.)</li> <li>• Are any DTCs present?</li> </ul>	Yes	Go to applicable DTC inspection.
		No	Troubleshooting completed.

05-02

# ON-BOARD DIAGNOSTIC

**DTC P0762**

A3U050201030W26

DTC P0762	Shift solenoid C stuck ON
<b>DETECTION CONDITION</b>	<ul style="list-style-type: none"> <li>• When either of DTC P0731 and P0732 are not generated, and both the following conditions are satisfied.                             <ul style="list-style-type: none"> <li>— When all conditions below satisfied while driving in 3GR.                                     <ul style="list-style-type: none"> <li>• ATF temperature <b>20 °C {68 °F} or above.</b></li> <li>• Driving in D range.</li> <li>• Engine run.</li> <li>• Turbine speed <b>within 225—4,988 rpm.</b></li> <li>• Differential gear case (output) revolution speed <b>35 rpm or above.</b></li> <li>• Revolution ratio of forward clutch drum revolution to differential gear case revolution <b>below 0.863 or 1.249 or above.</b></li> </ul> </li> <li>• Any of the following not generated: DTC P0500, P0705, P0706, P0710, P0715, P0751, P0752, P0753, P0756, P0757, P0758, P0761, P0762, P0763, P0766, P0767, P0768, P0771, P0772, P0773.</li> </ul> </li> <li>— When all conditions below satisfied while driving in 4GR.                                     <ul style="list-style-type: none"> <li>• ATF temperature <b>20 °C {68 °F} or above.</b></li> <li>• Driving in D range.</li> <li>• Engine run.</li> <li>• Turbine speed <b>within 225—4,988 rpm.</b></li> <li>• Vehicle speed <b>50 km/h {31mph} or above.</b></li> <li>• Differential gear case (output) revolution speed <b>35 rpm or above.</b></li> <li>• Throttle opening angle at closed throttle position</li> <li>• Revolution ratio of forward clutch drum revolution to differential gear case revolution <b>below 0.6 or 1.249 or above.</b></li> <li>• Any of the following not generated: DTC P0500, P0705, P0706, P0710, P0715, P0751, P0752, P0753, P0756, P0757, P0758, P0761, P0762, P0763, P0766, P0767, P0768, P0771, P0772, P0773.</li> </ul> </li> </ul> <p><b>Diagnostic support note:</b></p> <ul style="list-style-type: none"> <li>• This is a continuous monitor (CCM).</li> <li>• MIL illuminates if PCM detects the above malfunction conditions during two consecutive drive cycles.</li> <li>• PENDING CODE is available.</li> <li>• FREEZE FRAME DATA is available.</li> <li>• O/D OFF indicator light flashes.</li> <li>• DTC is stored in the PCM memory.</li> </ul>
<b>POSSIBLE CAUSE</b>	<ul style="list-style-type: none"> <li>• ATF level low</li> <li>• Deteriorated ATF</li> <li>• Shift solenoid C and pressure control solenoid stuck</li> <li>• Control valve stuck</li> <li>• PCM malfunction</li> </ul>

**Diagnostic procedure**

STEP	INSPECTION		ACTION
1	<b>VERIFY FREEZE FRAME DATA HAS BEEN RECORDED</b> <ul style="list-style-type: none"> <li>• Has FREEZE FRAME PID DATA been recorded?</li> </ul>	Yes	Go to next step.
		No	Record FREEZE FRAME PID DATA on repair order, then go to next step.
2	<b>VERIFY RELATED REPAIR INFORMATION AVAILABILITY</b> <ul style="list-style-type: none"> <li>• Check for related Service Bulletins availability.</li> <li>• Is any related repair information available?</li> </ul>	Yes	Perform repair or diagnosis according to available repair information. <ul style="list-style-type: none"> <li>• If vehicle is not repaired, go to next step.</li> </ul>
		No	Go to next step.
3	<b>CHECK ATF CONDITION</b> <ul style="list-style-type: none"> <li>• Turn ignition key to OFF.</li> <li>• Check ATF condition.                             <ul style="list-style-type: none"> <li>— Clear red: Normal</li> <li>— Milky: Water mixed in fluid</li> <li>— Reddish brown: Deteriorated ATF</li> </ul> </li> <li>• Is it okay?</li> </ul> (See 05–17–17 Automatic Transaxle Fluid (ATF) Condition Inspection.)	Yes	Go to next step.
		No	If ATF color milky or reddish brown, replace ATF, then go to Step 5. (See 05–17–18 AUTOMATIC TRANSAXLE FLUID (ATF) REPLACEMENT.)
4	<b>CHECK ATF LEVEL</b> <ul style="list-style-type: none"> <li>• Start engine.</li> <li>• Warm up ATX.</li> <li>• Is ATF level within specification?</li> </ul> (See 05–17–18 Automatic Transaxle Fluid (ATF) Level Inspection.)	Yes	Go to next step.
		No	Adjust ATF level, then go to Step 7. (See 05–17–18 Automatic Transaxle Fluid (ATF) Level Inspection.)



## ON-BOARD DIAGNOSTIC

STEP	INSPECTION	ACTION	
5	<b>INSPECT LINE PRESSURE</b> <ul style="list-style-type: none"> <li>• Start engine.</li> <li>• Measure line pressure.</li> </ul> <b>Specification</b> <b>FS engine</b> <b>Idle: 330—470 kPa {3.4—4.7 kgf/cm<sup>2</sup>, 49—66 psi}</b> <b>Stall: 1,160—1,320 kPa {11.9—13.4 kgf/cm<sup>2</sup>, 170—190 psi}</b> <b>ZM engine</b> <b>Idle: 330—470 kPa {3.4—4.7 kgf/cm<sup>2</sup>, 49—66 psi}</b> <b>Stall: 1,200—1,360 kPa {12.3—13.8 kgf/cm<sup>2</sup>, 175—196 psi}</b> <ul style="list-style-type: none"> <li>• Is line pressure within specification? (See 05-17-12 Line Pressure Test.)</li> </ul>	Yes	Go to next step.
		No	<ul style="list-style-type: none"> <li>• All ranges: Replace oil pump or control valve body, then go to Step 7.</li> <li>• Any ranges: Replace ATX, then go to Step 7. (See 05-17-31 AUTOMATIC TRANSAXLE (ATX) REMOVAL/INSTALLATION.) (See ATX Workshop Manual FN4A-EL (9999-95-FN4A-99).)</li> </ul>
6	<b>CHECK OPERATION OF EACH VALVE AND EACH SPRING</b> <ul style="list-style-type: none"> <li>• Turn ignition key to OFF.</li> <li>• Remove control valve body.</li> <li>• Disassemble control valve body.</li> <li>• Is each valve operation okay and is return spring okay? (See 05-17-36 CONTROL VALVE BODY REMOVAL/INSTALLATION.) (See ATX Workshop Manual FN4A-EL (9999-95-FN4A-99).)</li> </ul>	Yes	Replace ATX, then go to next step (See ATX Workshop Manual FN4A-EL (9999-95-FN4A-99).)
		No	Repair or replace shift valve and return spring, then go to next step. (See 05-17-36 CONTROL VALVE BODY REMOVAL/INSTALLATION.) (See ATX Workshop Manual FN4A-EL (9999-95-FN4A-99).)
7	<b>VERIFY TROUBLESHOOTING OF DTC P0762 COMPLETED</b> <ul style="list-style-type: none"> <li>• Make sure to reconnect all disconnected connectors.</li> <li>• Clear DTC from memory using WDS or equivalent.</li> <li>• Start engine.</li> <li>• Warm up ATX.</li> <li>• Drive the vehicle under the following conditions and make sure that gears shift smoothly from 1GR to 4GR.                             <ul style="list-style-type: none"> <li>— ATF temperature: <b>20 °C {68 °F} or above</b></li> <li>— Drive in D range</li> <li>— Throttle opening angle (TP PID): <b>0%</b> (4GR only)</li> <li>— Vehicle speed (VSS PID): <b>50 km/h {31 mph} or above</b> (4GR only)</li> </ul> </li> <li>• Is pending code present?</li> </ul>	Yes	Replace PCM, then go to next step. (See 01-40A-7 PCM REMOVAL/INSTALLATION [ZM].) (See 01-40B-7 PCM REMOVAL/INSTALLATION [FS].)
		No	Go to next step.
8	<b>VERIFY AFTER REPAIR PROCEDURE</b> <ul style="list-style-type: none"> <li>• Perform "After Repair Procedure". (See 05-02-6 AFTER REPAIR PROCEDURE.)</li> <li>• Are any DTCs present?</li> </ul>	Yes	Go to applicable DTC inspection.
		No	Troubleshooting completed.

05-02

# ON-BOARD DIAGNOSTIC

DTC P0763

A3U050201030W27

<b>DTC P0763</b>	<b>Shift solenoid C malfunction (electrical)</b>
<b>DETECTION CONDITION</b>	<ul style="list-style-type: none"> <li>• If PCM detects either of following conditions, PCM determines that shift solenoid C circuit has a malfunction:                             <ul style="list-style-type: none"> <li>— Shift solenoid C voltage is stuck at <b>B+</b> after engine start.</li> <li>— Shift solenoid C voltage is stuck at <b>0 V</b> after engine start.</li> </ul> </li> </ul> <p><b>Diagnostic support note:</b></p> <ul style="list-style-type: none"> <li>• This is a continuous monitor (CCM).</li> <li>• MIL illuminates if PCM detects the above malfunction conditions during first drive cycle.</li> <li>• PENDING CODE is not available.</li> <li>• FREEZE FRAME DATA is available.</li> <li>• O/D OFF indicator light flashes.</li> <li>• DTC is stored in the PCM memory.</li> </ul>
<b>POSSIBLE CAUSE</b>	<ul style="list-style-type: none"> <li>• Shift solenoid C malfunction</li> <li>• Short to ground between ATX connector terminal G and PCM terminal 102</li> <li>• Short to power between ATX connector terminal G and PCM terminal 102</li> <li>• Open circuit between shift solenoid C terminal B and ATX connector terminal G</li> <li>• Open circuit between ATX connector terminal G and PCM terminal 102</li> <li>• Open circuit between shift solenoid C terminal A and body ground point</li> <li>• Damaged connector between shift solenoid C and PCM.</li> <li>• PCM malfunction.</li> </ul>

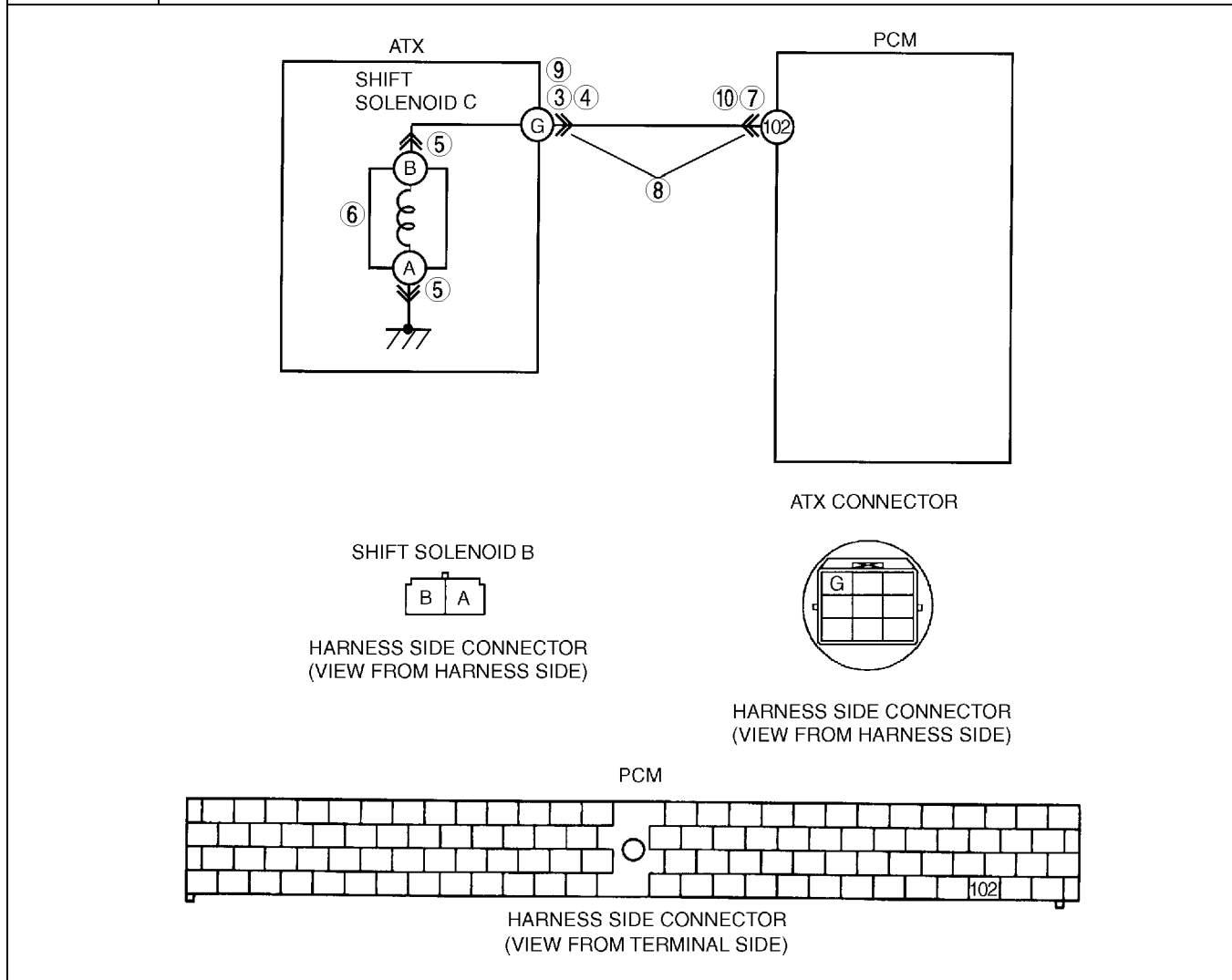

**Diagnostic procedure**

STEP	INSPECTION		ACTION
1	<b>VERIFY FREEZE FRAME DATA HAS BEEN RECORDED</b> <ul style="list-style-type: none"> <li>• Has FREEZE FRAME PID DATA been recorded?</li> </ul>	Yes	Go to next step.
		No	Record FREEZE FRAME PID DATA on repair order, then go to next step.

## ON-BOARD DIAGNOSTIC

STEP	INSPECTION		ACTION
2	<b>VERIFY RELATED REPAIR INFORMATION AVAILABILITY</b> <ul style="list-style-type: none"> <li>Check for related Service Bulletins availability.</li> <li>Is any related repair information available?</li> </ul>	Yes	Perform repair or diagnosis according to available repair information. <ul style="list-style-type: none"> <li>If vehicle is not repaired, go to next step.</li> </ul>
		No	Go to next step.
3	<b>INSPECT ATX CONNECTOR FOR POOR CONNECTION</b> <ul style="list-style-type: none"> <li>Turn ignition key to OFF.</li> <li>Disconnect ATX connector.</li> <li>Check for poor connection (damaged/pulled-out terminals, corrosion, etc.).</li> <li>Is connection okay?</li> </ul>	Yes	Go to next step.
		No	Repair or replace connector and/or terminals, then go to Step 11.
4	<b>INSPECT RESISTANCE</b> <ul style="list-style-type: none"> <li>Inspect resistance between ATX connector terminal G (transaxle case side) and body ground.</li> <li>Is resistance <b>within 1.0—4.2 ohms</b>? (See 05-17-28 Inspection of Resistance (On-vehicle).)</li> </ul>	Yes	Go to Step 7.
		No	Go to next step.
5	<b>INSPECT SHIFT SOLENOID C CONNECTOR FOR POOR CONNECTION</b> <ul style="list-style-type: none"> <li>Disconnect shift solenoid C connector.</li> <li>Check for poor connection (damaged/pulled-out terminals, corrosion, etc.).</li> <li>Is connection okay?</li> </ul>	Yes	Go to next step.
		No	Repair or replace connector and/or terminal, then go to Step 11.
6	<b>INSPECT RESISTANCE</b> <ul style="list-style-type: none"> <li>Inspect resistance between shift solenoid C terminals A and B (part-side).</li> <li>Is resistance <b>within 1.0—4.2 ohms</b>? (See 05-17-29 Resistance Inspection (Off-vehicle).)</li> </ul>	Yes	Replace solenoid harness, then go to Step 11.
		No	Verify shift solenoid C installation. <ul style="list-style-type: none"> <li>If solenoid installed correctly, replace solenoid, then go to Step 11.</li> </ul> (See 05-17-30 SOLENOID VALVES REMOVAL/INSTALLATION.)
7	<b>INSPECT PCM CONNECTOR FOR POOR CONNECTION</b> <ul style="list-style-type: none"> <li>Disconnect PCM connector.</li> <li>Check for poor connection (damaged/pulled-out terminals, corrosion, etc.).</li> <li>Is connection okay?</li> </ul>	Yes	Go to next step.
		No	Repair or replace connector and/or terminals, then go to Step 11.
8	<b>INSPECT ATX CONNECTOR CIRCUIT FOR OPEN</b> <ul style="list-style-type: none"> <li>inspect for continuity between PCM terminal 102 (harness-side) and ATX connector terminal G (vehicle harness-side).</li> <li>Is there continuity between terminals?</li> </ul>	Yes	Go to next step.
		No	Repair or replace harness, then go to Step 11.
9	<b>INSPECT ATX CONNECTOR CIRCUIT FOR SHORT TO POWER</b> <ul style="list-style-type: none"> <li>Turn ignition key to ON (engine OFF).</li> <li>Check voltage at ATX connector terminal G (vehicle harness-side).</li> <li>Is voltage <b>0 V</b>?</li> </ul>	Yes	Go to next step.
		No	Repair or replace harness, then go to Step 11.
10	<b>INSPECT PCM CIRCUIT FOR SHORT TO GROUND</b> <ul style="list-style-type: none"> <li>Turn ignition key to OFF.</li> <li>Inspect for continuity between PCM terminal 102 (harness-side) and body ground.</li> <li>Is there continuity?</li> </ul>	Yes	Repair or replace harness, then go to Step 11.
		No	Go to next step.
11	<b>VERIFY TROUBLESHOOTING OF DTC P0763 COMPLETED</b> <ul style="list-style-type: none"> <li>Make sure to reconnect all disconnected connectors.</li> <li>Clear DTC from memory using WDS or equivalent.</li> <li>Drive vehicle in D range and make sure that gears shift smoothly from 1GR to 4GR.</li> <li>Are any DTCs present?</li> </ul>	Yes	Replace PCM, then go to next step. (See 01-40A-7 PCM REMOVAL/INSTALLATION [ZM].) (See 01-40B-7 PCM REMOVAL/INSTALLATION [FS].)
		No	No concern is detected. Go to next step.
12	<b>VERIFY AFTER REPAIR PROCEDURE</b> <ul style="list-style-type: none"> <li>Perform "After Repair Procedure". (See 05-02-6 AFTER REPAIR PROCEDURE.)</li> <li>Are any DTCs present?</li> </ul>	Yes	Go to applicable DTC inspection.
		No	Troubleshooting completed.

05-02

# ON-BOARD DIAGNOSTIC

**DTC P0766**

A3U050201030W28

<b>DTC P0766</b>	<b>Shift solenoid D stuck OFF</b>
<b>DETECTION CONDITION</b>	<ul style="list-style-type: none"> <li>• When any of DTC P0731, P0732, and P0733 not output (correct judgment), and all conditions below are satisfied. <ul style="list-style-type: none"> <li>— ATF temperature <b>20 °C {68 °F} or above.</b></li> <li>— Driving in 4GR at D range.</li> <li>— Engine run.</li> <li>— Turbine speed <b>within 225—4,988 rpm.</b></li> <li>— Differential gear case (output) revolution speed <b>35 rpm or above.</b></li> <li>— Vehicle speed <b>50 km/h {31 mph} or above.</b></li> <li>— Throttle opening angle closed throttle position.</li> <li>— Revolution ratio of forward clutch drum revolution to differential gear case revolution <b>below 0.6 or 1.249 or above.</b></li> <li>— Any of the following not generated: DTC P0500, P0705, P0706, P0710, P0715, P0751, P0752, P0753, P0756, P0757, P0758, P0761, P0762, P0763, P0766, P0767, P0768, P0771, P0772, P0773.</li> </ul> </li> </ul> <p><b>Diagnostic support note:</b></p> <ul style="list-style-type: none"> <li>• This is a continuous monitor (CCM).</li> <li>• MIL illuminates if PCM detects the above malfunction conditions during two consecutive drive cycles.</li> <li>• PENDING CODE is available.</li> <li>• FREEZE FRAME DATA is available.</li> <li>• O/D OFF indicator light flashes.</li> <li>• DTC is stored in the PCM memory.</li> </ul>
<b>POSSIBLE CAUSE</b>	<ul style="list-style-type: none"> <li>• ATF level low</li> <li>• Deteriorated ATF</li> <li>• Shift solenoid D stuck</li> <li>• Control valve stuck</li> <li>• PCM malfunction</li> </ul>

**Diagnostic procedure**

STEP	INSPECTION		ACTION
1	<b>VERIFY FREEZE FRAME DATA HAS BEEN RECORDED</b> <ul style="list-style-type: none"> <li>• Has FREEZE FRAME PID DATA been recorded?</li> </ul>	Yes	Go to next step.
		No	Record FREEZE FRAME PID DATA on repair order, then go to next step.
2	<b>VERIFY RELATED REPAIR INFORMATION AVAILABILITY</b> <ul style="list-style-type: none"> <li>• Check for related Service Bulletins availability.</li> <li>• Is any related repair information available?</li> </ul>	Yes	Perform repair or diagnosis according to available repair information. <ul style="list-style-type: none"> <li>• If vehicle is not repaired, go to next step.</li> </ul>
		No	Go to next step.
3	<b>CHECK ATF CONDITION</b> <ul style="list-style-type: none"> <li>• Turn ignition key to OFF.</li> <li>• Check ATF condition. <ul style="list-style-type: none"> <li>— Clear red: Normal</li> <li>— Milky: Water mixed in fluid</li> <li>— Reddish brown: Deteriorated ATF</li> </ul> </li> <li>• Is it okay?</li> </ul> (See 05–17–17 Automatic Transaxle Fluid (ATF) Condition Inspection.)	Yes	Go to next step.
		No	If ATF color milky or reddish brown, replace ATF, then go to Step 5. (See 05–17–18 AUTOMATIC TRANSAXLE FLUID (ATF) REPLACEMENT.)
4	<b>CHECK ATF LEVEL</b> <ul style="list-style-type: none"> <li>• Start engine.</li> <li>• Warm up ATX.</li> <li>• Is ATF level within specification?</li> </ul> (See 05–17–18 Automatic Transaxle Fluid (ATF) Level Inspection.)	Yes	Go to next step.
		No	Adjust ATF level, then go to Step 7. (See 05–17–18 Automatic Transaxle Fluid (ATF) Level Inspection.)

## ON-BOARD DIAGNOSTIC

STEP	INSPECTION	ACTION	
5	<b>INSPECT LINE PRESSURE</b> <ul style="list-style-type: none"> <li>• Start engine.</li> <li>• Measure line pressure.</li> </ul> <b>Specification</b> <b>FS engine</b> <b>Idle: 330—470 kPa {3.4—4.7 kgf/cm<sup>2</sup>, 49—66 psi}</b> <b>Stall: 1,160—1,320 kPa {11.9—13.4 kgf/cm<sup>2</sup>, 170—190 psi}</b> <b>ZM engine</b> <b>Idle: 330—470 kPa {3.4—4.7 kgf/cm<sup>2</sup>, 49—66 psi}</b> <b>Stall: 1,200—1,360 kPa {12.3—13.8 kgf/cm<sup>2</sup>, 175—196 psi}</b> <ul style="list-style-type: none"> <li>• Is line pressure within specification? (See 05-17-12 Line Pressure Test.)</li> </ul>	Yes	Go to next step.
		No	<ul style="list-style-type: none"> <li>• All ranges: Replace oil pump or control valve body, then go to Step 7.</li> <li>• Any ranges: Replace ATX, then go to Step 7. (See 05-17-31 AUTOMATIC TRANSAXLE (ATX) REMOVAL/INSTALLATION.) (See ATX Workshop Manual FN4A-EL (9999-95-FN4A-99).)</li> </ul>
6	<b>CHECK OPERATION OF EACH VALVE AND EACH SPRING</b> <ul style="list-style-type: none"> <li>• Turn ignition key to OFF.</li> <li>• Remove control valve body.</li> <li>• Disassemble control valve body.</li> <li>• Is each valve operation okay and is return spring okay? (See 05-17-36 CONTROL VALVE BODY REMOVAL/INSTALLATION.) (See ATX Workshop Manual FN4A-EL (9999-95-FN4A-99).)</li> </ul>	Yes	Replace ATX, then go to next step (See ATX Workshop Manual FN4A-EL (9999-95-FN4A-99).)
		No	Repair or replace shift valve and return spring, then go to next step. (See 05-17-36 CONTROL VALVE BODY REMOVAL/INSTALLATION.) (See ATX Workshop Manual FN4A-EL (9999-95-FN4A-99).)
7	<b>VERIFY TROUBLESHOOTING OF DTC P0766 COMPLETED</b> <ul style="list-style-type: none"> <li>• Make sure to reconnect all disconnected connectors.</li> <li>• Clear DTC from memory using WDS or equivalent.</li> <li>• Start engine.</li> <li>• Warm up ATX.</li> <li>• Drive the vehicle under the following conditions and make sure that gears shift smoothly from 1GR to 4GR.                             <ul style="list-style-type: none"> <li>— ATF temperature: <b>20 °C {68 °F} or above</b></li> <li>— Drive in D range</li> <li>— Throttle opening angle (TP PID): <b>0%</b> (4GR only)</li> <li>— Vehicle speed: <b>50 km/h {31 mph} or above.</b> (4GR only) (VSS PID)</li> </ul> </li> <li>• Is pending code present?</li> </ul>	Yes	Replace PCM, then go to next step. (See 01-40A-7 PCM REMOVAL/INSTALLATION [ZM].) (See 01-40B-7 PCM REMOVAL/INSTALLATION [FS].)
		No	Go to next step.
8	<b>VERIFY AFTER REPAIR PROCEDURE</b> <ul style="list-style-type: none"> <li>• Perform "After Repair Procedure". (See 05-02-6 AFTER REPAIR PROCEDURE.)</li> <li>• Are any DTCs present?</li> </ul>	Yes	Go to applicable DTC inspection.
		No	Troubleshooting completed.

05-02

# ON-BOARD DIAGNOSTIC

**DTC P0767**

A3U050201030W29

<b>DTC P0767</b>	<b>Shift solenoid D stuck ON</b>
<b>DETECTION CONDITION</b>	<ul style="list-style-type: none"> <li>• When any of DTC P0731, P0732, P0734, and P0741 are not generated, and all conditions below are satisfied.                             <ul style="list-style-type: none"> <li>— ATF temperature <b>20 °C {68 °F} or above.</b></li> <li>— Driving in D range.</li> <li>— Engine run.</li> <li>— Turbine speed <b>within 225—4,988 rpm.</b></li> <li>— Differential gear case (output) revolution speed <b>35 rpm or above.</b></li> <li>— Revolution ratio of forward clutch drum revolution to differential gear case revolution <b>below 0.863 or 1.249 or above.</b></li> <li>— Any of the following not generated: DTC P0500, P0705, P0706, P0710, P0715, P0751, P0752, P0753, P0756, P0757, P0758, P0761, P0762, P0763, P0766, P0767, P0768, P0771, P0772, P0773.</li> </ul> </li> </ul> <p><b>Diagnostic support note:</b></p> <ul style="list-style-type: none"> <li>• This is a continuous monitor (CCM).</li> <li>• MIL illuminates if PCM detects the above malfunction conditions during two consecutive drive cycles.</li> <li>• PENDING CODE is available.</li> <li>• FREEZE FRAME DATA is available.</li> <li>• O/D OFF indicator light flashes.</li> <li>• DTC is stored in the PCM memory.</li> </ul>
<b>POSSIBLE CAUSE</b>	<ul style="list-style-type: none"> <li>• ATF level low</li> <li>• Deteriorated ATF</li> <li>• Shift solenoid D stuck</li> <li>• Control valve stuck</li> <li>• PCM malfunction</li> </ul>

**Diagnostic procedure**

STEP	INSPECTION		ACTION
1	<b>VERIFY FREEZE FRAME DATA HAS BEEN RECORDED</b> <ul style="list-style-type: none"> <li>• Has FREEZE FRAME PID DATA been recorded?</li> </ul>	Yes	Go to next step.
		No	Record FREEZE FRAME PID DATA on repair order, then go to next step.
2	<b>VERIFY RELATED REPAIR INFORMATION AVAILABILITY</b> <ul style="list-style-type: none"> <li>• Check for related Service Bulletins availability.</li> <li>• Is any related repair information available?</li> </ul>	Yes	Perform repair or diagnosis according to available repair information. <ul style="list-style-type: none"> <li>• If vehicle is not repaired, go to next step.</li> </ul>
		No	Go to next step.
3	<b>CHECK ATF CONDITION</b> <ul style="list-style-type: none"> <li>• Turn ignition key to OFF.</li> <li>• Check ATF condition.                                     <ul style="list-style-type: none"> <li>— Clear red: Normal</li> <li>— Milky: Water mixed in fluid</li> <li>— Reddish brown: Deteriorated ATF</li> </ul> </li> <li>• Is it okay?</li> </ul> (See 05–17–17 Automatic Transaxle Fluid (ATF) Condition Inspection.)	Yes	Go to next step.
		No	If ATF color milky or reddish brown, replace ATF, then go to Step 5. (See 05–17–18 AUTOMATIC TRANSAXLE FLUID (ATF) REPLACEMENT.)
4	<b>CHECK ATF LEVEL</b> <ul style="list-style-type: none"> <li>• Start engine.</li> <li>• Warm up ATX.</li> <li>• Is ATF level within specification?</li> </ul> (See 05–17–18 Automatic Transaxle Fluid (ATF) Level Inspection.)	Yes	Go to next step.
		No	Adjust ATF level, then go to Step 7. (See 05–17–18 Automatic Transaxle Fluid (ATF) Level Inspection.)
5	<b>INSPECT LINE PRESSURE</b> <ul style="list-style-type: none"> <li>• Start engine.</li> <li>• Measure line pressure.</li> </ul> <b>Specification</b> <b>FS engine</b> Idle: 330—470 kPa {3.4—4.7 kgf/cm <sup>2</sup> , 49—66 psi} Stall: 1,160—1,320 kPa {11.9—13.4 kgf/cm <sup>2</sup> , 170—190 psi} <b>ZM engine</b> Idle: 330—470 kPa {3.4—4.7 kgf/cm <sup>2</sup> , 49—66 psi} Stall: 1,200—1,360 kPa {12.3—13.8 kgf/cm <sup>2</sup> , 175—196 psi}	Yes	Go to next step.
		No	<ul style="list-style-type: none"> <li>• All ranges: Replace oil pump or control valve body, then go to Step 7.</li> <li>• Any ranges: Replace ATX, then go to Step 7. (See 05–17–31 AUTOMATIC TRANSAXLE (ATX) REMOVAL/INSTALLATION.) (See ATX Workshop Manual FN4A-EL (9999-95-FN4A-99).)</li> </ul>

## ON-BOARD DIAGNOSTIC

STEP	INSPECTION	ACTION	
6	<b>CHECK OPERATION OF EACH VALVE AND EACH SPRING</b> <ul style="list-style-type: none"> <li>• Turn ignition key to OFF.</li> <li>• Remove control valve body.</li> <li>• Disassemble control valve body.</li> <li>• Is each valve operation okay and is return spring okay?</li> </ul> (See 05-17-36 CONTROL VALVE BODY REMOVAL/INSTALLATION.) (See ATX Workshop Manual FN4A-EL (9999-95-FN4A-99).)	Yes	Replace ATX, then go to next step. (See ATX Workshop Manual FN4A-EL (9999-95-FN4A-99).)
		No	Repair or replace shift valve and return spring, then go to next step. (See 05-17-36 CONTROL VALVE BODY REMOVAL/INSTALLATION.) (See ATX Workshop Manual FN4A-EL (9999-95-FN4A-99).)
7	<b>VERIFY TROUBLESHOOTING OF DTC P0767 COMPLETED</b> <ul style="list-style-type: none"> <li>• Make sure to reconnect all disconnected connectors.</li> <li>• Clear DTC from memory using WDS or equivalent.</li> <li>• Start engine.</li> <li>• Warm up ATX.</li> <li>• Drive the vehicle under the following conditions and make sure that gears shift smoothly from 1GR to 4GR.                             <ul style="list-style-type: none"> <li>— ATF temperature: <b>20 °C {68 °F} or above</b></li> <li>— Drive in D range</li> </ul> </li> <li>• Is pending code present?</li> </ul>	Yes	Replace PCM, then go to next step. (See 01-40A-7 PCM REMOVAL/INSTALLATION [ZM].) (See 01-40B-7 PCM REMOVAL/INSTALLATION [FS].)
		No	Go to next step.
8	<b>VERIFY AFTER REPAIR PROCEDURE</b> <ul style="list-style-type: none"> <li>• Perform "After Repair Procedure". (See 05-02-6 AFTER REPAIR PROCEDURE.)</li> <li>• Are any DTCs present?</li> </ul>	Yes	Go to applicable DTC inspection.
		No	Troubleshooting completed.

05-02

# ON-BOARD DIAGNOSTIC

**DTC P0768**

A3U050201030W30

<b>DTC P0768</b>	<b>Shift solenoid D malfunction (electrical)</b>
<b>DETECTION CONDITION</b>	<ul style="list-style-type: none"> <li>• If PCM detects either of following conditions while driving in 4GR at D range, PCM determines that shift solenoid D circuit has a malfunction:                             <ul style="list-style-type: none"> <li>— Shift solenoid D voltage is stuck at <b>B+</b> after engine start.</li> <li>— Shift solenoid D voltage is stuck at <b>0 V</b> after engine start.</li> </ul> </li> </ul> <p><b>Diagnostic support note:</b></p> <ul style="list-style-type: none"> <li>• This is a continuous monitor (CCM).</li> <li>• MIL illuminates if PCM detects the above malfunction conditions during first drive cycle.</li> <li>• PENDING CODE is not available.</li> <li>• FREEZE FRAME DATA is available.</li> <li>• O/D OFF indicator light flashes.</li> <li>• DTC is stored in the PCM memory.</li> </ul>
<b>POSSIBLE CAUSE</b>	<ul style="list-style-type: none"> <li>• Shift solenoid D malfunction</li> <li>• Short to ground between ATX connector terminal B and PCM terminal 27</li> <li>• Short to power between ATX connector terminal B and PCM terminal 27</li> <li>• Open circuit between shift solenoid D terminal A and ATX connector terminal B</li> <li>• Open circuit between ATX connector terminal B and PCM terminal 27</li> <li>• Damaged connector between shift solenoid D and PCM</li> <li>• PCM malfunction</li> </ul>

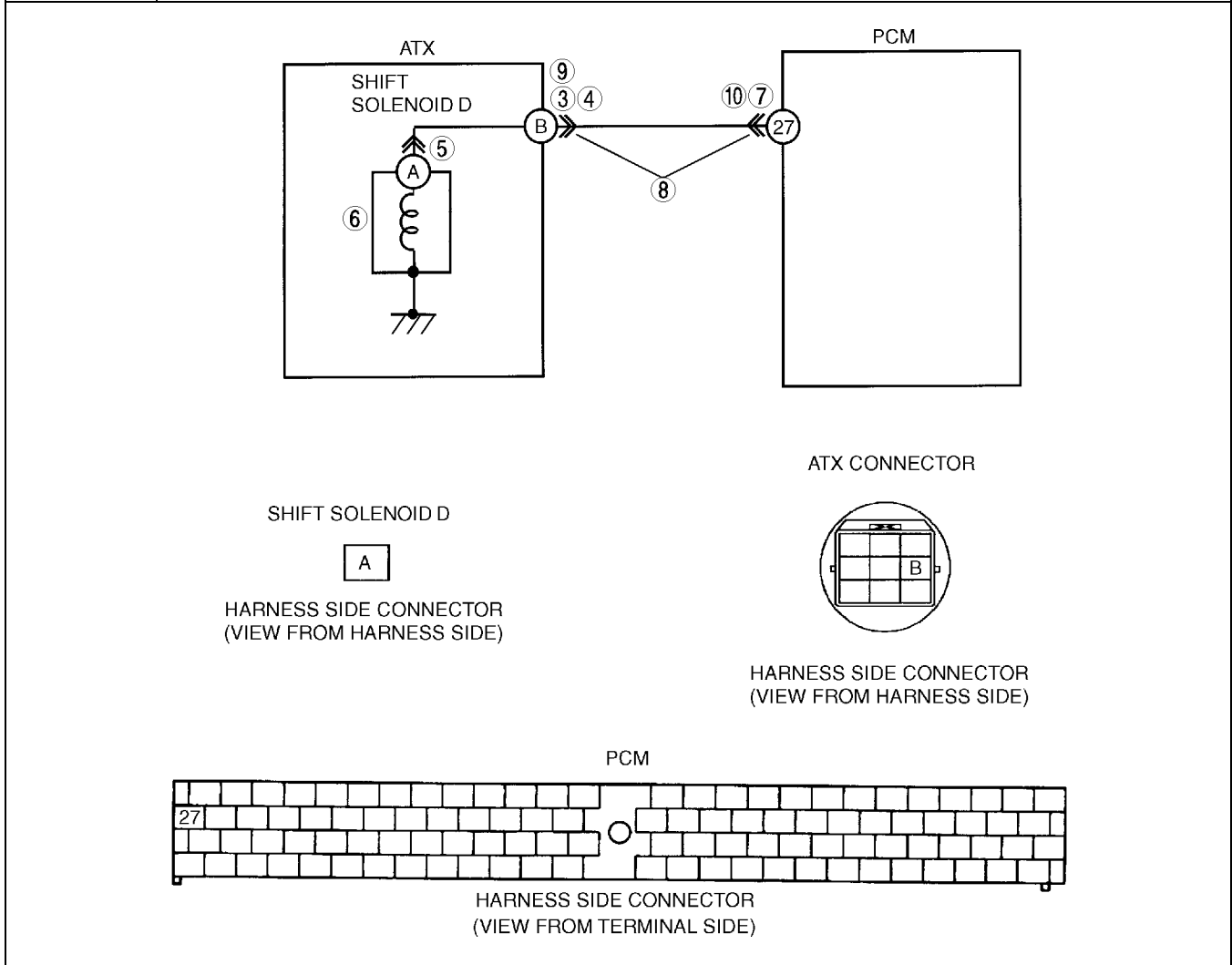

**Diagnostic procedure**

STEP	INSPECTION		ACTION
1	<b>VERIFY FREEZE FRAME DATA HAS BEEN RECORDED</b> <ul style="list-style-type: none"> <li>• Has FREEZE FRAME PID DATA been recorded?</li> </ul>	Yes	Go to next step.
		No	Record FREEZE FRAME PID DATA on repair order, then go to next step.



## ON-BOARD DIAGNOSTIC

STEP	INSPECTION		ACTION
2	<b>VERIFY RELATED REPAIR INFORMATION AVAILABILITY</b> <ul style="list-style-type: none"> <li>Check for related Service Bulletins availability.</li> <li>Is any related repair information available?</li> </ul>	Yes	Perform repair or diagnosis according to available repair information. <ul style="list-style-type: none"> <li>If vehicle is not repaired, go to next step.</li> </ul>
		No	Go to next step.
3	<b>INSPECT ATX CONNECTOR FOR POOR CONNECTION</b> <ul style="list-style-type: none"> <li>Turn ignition key to OFF.</li> <li>Disconnect ATX connector.</li> <li>Check for poor connection (damaged/pulled-out terminals, corrosion, etc.).</li> <li>Is connection okay?</li> </ul>	Yes	Go to next step.
		No	Repair or replace connector and/or terminals, then go to Step 11.
4	<b>INSPECT RESISTANCE</b> <ul style="list-style-type: none"> <li>Inspect resistance between ATX connector terminal B (transaxle case side) and body ground.</li> <li>Is resistance <b>within 10.9—26.2 ohms</b>? (See 05-17-28 Inspection of Resistance (On-vehicle).)</li> </ul>	Yes	Go to Step 7.
		No	Go to next step.
5	<b>INSPECT SHIFT SOLENOID D CONNECTOR FOR POOR CONNECTION</b> <ul style="list-style-type: none"> <li>Disconnect shift solenoid D connector.</li> <li>Check for poor connection (damaged/pulled-out terminals, corrosion, etc.).</li> <li>Is connection okay?</li> </ul>	Yes	Go to next step.
		No	Repair or replace connector and/or terminal, then go to Step 11.
6	<b>INSPECT RESISTANCE</b> <ul style="list-style-type: none"> <li>inspect resistance between shift solenoid D terminal A (part-side) and body ground.</li> <li>Is resistance <b>within 10.9—26.2 ohms</b>? (See 05-17-29 Resistance Inspection (Off-vehicle).)</li> </ul>	Yes	Replace solenoid harness, then go to Step 11.
		No	Verify shift solenoid D installation. <ul style="list-style-type: none"> <li>If solenoid installed correctly, replace solenoid, then go to Step 11.</li> </ul> (See 05-17-30 SOLENOID VALVES REMOVAL/INSTALLATION.)
7	<b>INSPECT PCM CONNECTOR FOR POOR CONNECTION</b> <ul style="list-style-type: none"> <li>Disconnect PCM connector.</li> <li>Check for poor connection (damaged/pulled-out terminals, corrosion, etc.).</li> <li>Is connection okay?</li> </ul>	Yes	Go to next step.
		No	Repair or replace connector and/or terminals, then go to Step 11.
8	<b>INSPECT ATX CONNECTOR CIRCUIT FOR OPEN</b> <ul style="list-style-type: none"> <li>Inspect for continuity between PCM terminal 27 (harness-side) and ATX connector terminal B (vehicle harness-side).</li> <li>Is there continuity between terminals?</li> </ul>	Yes	Go to next step.
		No	Repair or replace harness, then go to Step 11.
9	<b>INSPECT ATX CONNECTOR CIRCUIT FOR SHORT TO POWER</b> <ul style="list-style-type: none"> <li>Turn ignition key to ON (engine OFF).</li> <li>Inspect voltage at ATX connector terminal B (vehicle harness-side).</li> <li>Is voltage <b>0 V</b>?</li> </ul>	Yes	Go to next step.
		No	Repair or replace harness, then go to Step 11.
10	<b>INSPECT PCM CIRCUIT FOR SHORT TO GROUND</b> <ul style="list-style-type: none"> <li>Turn ignition key to OFF.</li> <li>Inspect continuity between PCM terminal 27 (harness-side) and body ground.</li> <li>Is there continuity?</li> </ul>	Yes	Repair or replace harness, then go to Step 11.
		No	Go to next step.
11	<b>VERIFY TROUBLESHOOTING OF DTC P0768 COMPLETED</b> <ul style="list-style-type: none"> <li>Make sure to reconnect all disconnected connectors.</li> <li>Clear DTC from memory using WDS or equivalent.</li> <li>Drive vehicle in D range and make sure that gears shift smoothly from 1GR to 4GR.</li> <li>Are any DTCs present?</li> </ul>	Yes	Replace PCM, then go to next step. (See 01-40A-7 PCM REMOVAL/INSTALLATION [ZM].) (See 01-40B-7 PCM REMOVAL/INSTALLATION [FS].)
		No	No concern is detected. Go to next step.
12	<b>VERIFY AFTER REPAIR PROCEDURE</b> <ul style="list-style-type: none"> <li>Perform "After Repair Procedure". (See 05-02-6 AFTER REPAIR PROCEDURE.)</li> <li>Are any DTCs present?</li> </ul>	Yes	Go to applicable DTC inspection.
		No	Troubleshooting completed.

05-02

# ON-BOARD DIAGNOSTIC

**DTC P0771**

A3U050201030W31

<b>DTC P0771</b>	<b>Shift solenoid E stuck OFF</b>
<b>DETECTION CONDITION</b>	<ul style="list-style-type: none"> <li>• When any of P0731, P0732, and P0734 are not generated, and all conditions below are satisfied.               <ul style="list-style-type: none"> <li>— ATF temperature <b>20 °C {68 °F} or above.</b></li> <li>— Driving in 4GR at D range.</li> <li>— Engine run.</li> <li>— Turbine speed <b>within 225—4,988 rpm.</b></li> <li>— Vehicle speed <b>within 60—100 km/h {37—62 mph}.</b></li> <li>— TCC operation</li> <li>— Shift solenoid A duty value exceeds <b>99%</b></li> <li>— Power or normal mode</li> <li>— Difference between engine speed and turbine speed <b>more than 100 rpm</b></li> <li>— Any of the following not generated: DTC P0500, P0705, P0706, P0710, P0715, P0751, P0752, P0753, P0756, P0757, P0758, P0761, P0762, P0763, P0766, P0767, P0768, P0771, P0772, P0773.</li> </ul> </li> </ul> <p><b>Diagnostic support note:</b></p> <ul style="list-style-type: none"> <li>• This is a continuous monitor (CCM).</li> <li>• MIL illuminates if PCM detects the above malfunction conditions during two consecutive drive cycles.</li> <li>• PENDING CODE is available.</li> <li>• FREEZE FRAME DATA is available.</li> <li>• O/D OFF indicator light flashes.</li> <li>• DTC is stored in the PCM memory.</li> </ul>
<b>POSSIBLE CAUSE</b>	<ul style="list-style-type: none"> <li>• ATF level low</li> <li>• Deteriorated ATF</li> <li>• Shift solenoid E stuck</li> <li>• Control valve stuck</li> <li>• PCM malfunction</li> </ul>

**Diagnostic procedure**

STEP	INSPECTION		ACTION
1	<b>VERIFY FREEZE FRAME DATA HAS BEEN RECORDED</b> <ul style="list-style-type: none"> <li>• Has FREEZE FRAME PID DATA been recorded?</li> </ul>	Yes	Go to next step.
		No	Record FREEZE FRAME PID DATA on repair order, then go to next step.
2	<b>VERIFY RELATED REPAIR INFORMATION AVAILABILITY</b> <ul style="list-style-type: none"> <li>• Check for related Service Bulletins availability.</li> <li>• Is any related repair information available?</li> </ul>	Yes	Perform repair or diagnosis according to available repair information. <ul style="list-style-type: none"> <li>• If vehicle is not repaired, go to next step.</li> </ul>
		No	Go to next step.
3	<b>CHECK ATF CONDITION</b> <ul style="list-style-type: none"> <li>• Turn ignition key to OFF.</li> <li>• Check ATF condition.               <ul style="list-style-type: none"> <li>— Clear red: Normal</li> <li>— Milky: Water mixed in fluid</li> <li>— Reddish brown: Deteriorated ATF</li> </ul> </li> <li>• Is it okay?</li> </ul> (See 05–17–17 Automatic Transaxle Fluid (ATF) Condition Inspection.)	Yes	Go to next step.
		No	If ATF color milky or reddish brown, replace ATF, then go to Step 5. (See 05–17–18 AUTOMATIC TRANSAXLE FLUID (ATF) REPLACEMENT.)
4	<b>CHECK ATF LEVEL</b> <ul style="list-style-type: none"> <li>• Start engine.</li> <li>• Warm up ATX.</li> <li>• Is ATF level within specification?</li> </ul> (See 05–17–18 Automatic Transaxle Fluid (ATF) Level Inspection.)	Yes	Go to next step.
		No	Adjust ATF level, then go to Step 7. (See 05–17–18 Automatic Transaxle Fluid (ATF) Level Inspection.)

## ON-BOARD DIAGNOSTIC

STEP	INSPECTION	ACTION	
5	<b>INSPECT LINE PRESSURE</b> <ul style="list-style-type: none"> <li>• Start engine.</li> <li>• Measure line pressure.</li> </ul> <b>Specification</b> <b>FS engine</b> <b>Idle: 330—470 kPa {3.4—4.7 kgf/cm<sup>2</sup>, 49—66 psi}</b> <b>Stall: 1,160—1,320 kPa {11.9—13.4 kgf/cm<sup>2</sup>, 170—190 psi}</b> <b>ZM engine</b> <b>Idle: 330—470 kPa {3.4—4.7 kgf/cm<sup>2</sup>, 49—66 psi}</b> <b>Stall: 1,200—1,360 kPa {12.3—13.8 kgf/cm<sup>2</sup>, 175—196 psi}</b> <ul style="list-style-type: none"> <li>• Is line pressure within specification?</li> </ul> (See 05-17-12 Line Pressure Test.)	Yes	Go to next step.
		No	<ul style="list-style-type: none"> <li>• All ranges: Replace oil pump or control valve body, then go to Step 7.</li> <li>• Any ranges: Replace ATX, then go to Step 7.</li> </ul> (See 05-17-31 AUTOMATIC TRANSAXLE (ATX) REMOVAL/INSTALLATION.) (See ATX Workshop Manual FN4A-EL (9999-95-FN4A-99).)
6	<b>CHECK OPERATION OF EACH VALVE AND EACH SPRING</b> <ul style="list-style-type: none"> <li>• Turn ignition key to OFF.</li> <li>• Remove control valve body.</li> <li>• Disassemble control valve body.</li> <li>• Is each valve operation okay and is return spring okay?</li> </ul> (See 05-17-36 CONTROL VALVE BODY REMOVAL/INSTALLATION.) (See ATX Workshop Manual FN4A-EL (9999-95-FN4A-99).)	Yes	Replace ATX, then go to next step (See ATX Workshop Manual FN4A-EL (9999-95-FN4A-99).)
		No	Repair or replace shift valve and return spring, then go to next step. (See 05-17-36 CONTROL VALVE BODY REMOVAL/INSTALLATION.) (See ATX Workshop Manual FN4A-EL (9999-95-FN4A-99).)
7	<b>VERIFY TROUBLESHOOTING OF DTC P0771 COMPLETED</b> <ul style="list-style-type: none"> <li>• Make sure to reconnect all disconnected connectors.</li> <li>• Clear DTC from memory using WDS or equivalent.</li> <li>• Start engine.</li> <li>• Warm up ATX.</li> <li>• Drive the vehicle under the following conditions and make sure that gears shift smoothly from 1GR to 4GR.                             <ul style="list-style-type: none"> <li>— ATF temperature: <b>20 °C {68 °F} or above</b></li> <li>— Drive in D range</li> <li>— Vehicle speed: <b>within 60—100 km/h {37—62 mph}</b> (4th gear only).</li> </ul> </li> <li>• Is pending code present?</li> </ul>	Yes	Replace PCM, then go to next step. (See 01-40A-7 PCM REMOVAL/INSTALLATION [ZM].) (See 01-40B-7 PCM REMOVAL/INSTALLATION [FS].)
		No	Go to next step.
8	<b>VERIFY AFTER REPAIR PROCEDURE</b> <ul style="list-style-type: none"> <li>• Perform “After Repair Procedure”.</li> </ul> (See 05-02-6 AFTER REPAIR PROCEDURE.) <ul style="list-style-type: none"> <li>• Are any DTCs present?</li> </ul>	Yes	Go to applicable DTC inspection.
		No	Troubleshooting completed.

05-02

# ON-BOARD DIAGNOSTIC

DTC P0772

A3U050201030W32

DTC P0772	Shift solenoid E stuck ON
<b>DETECTION CONDITION</b>	<ul style="list-style-type: none"> <li>• When any of DTC P0731, P0733, and P0734 are not generated, and all of following conditions satisfied under each of following throttle conditions.                             <ul style="list-style-type: none"> <li>— ATF temperature <b>20 °C {68 °F} or above.</b></li> <li>— Driving in 4GR at D range.</li> <li>— Engine run.</li> <li>— Turbine speed <b>within 225—4,988 rpm.</b></li> <li>— Vehicle speed <b>below 70 km/h {43 mph}.</b></li> <li>— Torque converter clutch (TCC) no operation</li> <li>— Difference between engine speed and turbine speed <b>below 50 rpm</b></li> </ul> </li> <li>• Throttle conditions.                             <ul style="list-style-type: none"> <li>— <b>FS engine</b> <ul style="list-style-type: none"> <li>• Throttle opening angle (TP PID) <b>above 6.25%</b> and <b>10 seconds or more</b> have passed.</li> <li>• Throttle opening angle (TP PID) <b>within 3.13—6.25%</b> and <b>3 seconds or more</b> have passed.</li> <li>• Throttle opening angle at closed throttle position and <b>10 seconds or more</b> have passed.</li> </ul> </li> <li>— <b>ZM engine</b> <ul style="list-style-type: none"> <li>• Throttle opening angle (TP PID) <b>above 7.03%</b> and <b>10 seconds or more</b> have passed.</li> <li>• Throttle opening angle (TP PID) <b>within 1.56—7.03%</b> and <b>3 seconds or more</b> have passed.</li> <li>• Throttle opening angle at closed throttle position and <b>10 seconds or more</b> have passed.</li> </ul> </li> </ul> </li> </ul> <p><b>Diagnostic support note:</b></p> <ul style="list-style-type: none"> <li>• This is a continuous monitor (CCM).</li> <li>• MIL illuminates if PCM detects the above malfunction conditions during two consecutive drive cycles.</li> <li>• PENDING CODE is available.</li> <li>• FREEZE FRAME DATA is available.</li> <li>• O/D OFF indicator light flashes.</li> <li>• DTC is stored in the PCM memory.</li> </ul>
<b>POSSIBLE CAUSE</b>	<ul style="list-style-type: none"> <li>• ATF level low</li> <li>• Deteriorated ATF</li> <li>• Shift solenoid E stuck</li> <li>• Control valve stuck</li> <li>• PCM malfunction</li> </ul>

## Diagnostic procedure

STEP	INSPECTION		ACTION
1	<b>VERIFY FREEZE FRAME DATA HAS BEEN RECORDED</b> <ul style="list-style-type: none"> <li>• Has FREEZE FRAME PID DATA been recorded?</li> </ul>	Yes	Go to next step.
		No	Record FREEZE FRAME PID DATA on repair order, then go to next step.
2	<b>VERIFY RELATED REPAIR INFORMATION AVAILABILITY</b> <ul style="list-style-type: none"> <li>• Check for related Service Bulletins availability.</li> <li>• Is any related repair information available?</li> </ul>	Yes	Perform repair or diagnosis according to available repair information. <ul style="list-style-type: none"> <li>• If vehicle is not repaired, go to next step.</li> </ul>
		No	Go to next step.
3	<b>CHECK ATF CONDITION</b> <ul style="list-style-type: none"> <li>• Turn ignition key to OFF.</li> <li>• Check ATF condition.                                     <ul style="list-style-type: none"> <li>— Clear red: Normal</li> <li>— Milky: Water mixed in fluid</li> <li>— Reddish brown: Deteriorated ATF</li> </ul> </li> <li>• Is it okay?</li> </ul> (See 05–17–17 Automatic Transaxle Fluid (ATF) Condition Inspection.)	Yes	Go to next step.
		No	If ATF color milky or reddish brown, replace ATF, then go to Step 5. (See 05–17–18 AUTOMATIC TRANSAXLE FLUID (ATF) REPLACEMENT.)
4	<b>CHECK ATF LEVEL</b> <ul style="list-style-type: none"> <li>• Start engine.</li> <li>• Warm up ATX.</li> <li>• Is ATF level within specification?</li> </ul> (See 05–17–18 Automatic Transaxle Fluid (ATF) Level Inspection.)	Yes	Go to next step.
		No	Adjust ATF level, then go to Step 7. (See 05–17–18 Automatic Transaxle Fluid (ATF) Level Inspection.)

## ON-BOARD DIAGNOSTIC

STEP	INSPECTION	ACTION	
5	<b>INSPECT LINE PRESSURE</b> <ul style="list-style-type: none"> <li>• Start engine.</li> <li>• Measure line pressure.</li> </ul> <b>Specification</b> <b>FS engine</b> <b>Idle: 330—470 kPa {3.4—4.7 kgf/cm<sup>2</sup>, 49—66 psi}</b> <b>Stall: 1,160—1,320 kPa {11.9—13.4 kgf/cm<sup>2</sup>, 170—190 psi}</b> <b>ZM engine</b> <b>Idle: 330—470 kPa {3.4—4.7 kgf/cm<sup>2</sup>, 49—66 psi}</b> <b>Stall: 1,200—1,360 kPa {12.3—13.8 kgf/cm<sup>2</sup>, 175—196 psi}</b> <ul style="list-style-type: none"> <li>• Is line pressure within specification? (See 05-17-12 Line Pressure Test.)</li> </ul>	Yes	Go to next step.
		No	<ul style="list-style-type: none"> <li>• All ranges: Replace oil pump or control valve body, then go to Step 7.</li> <li>• Any ranges: Replace ATX, then go to Step 7. (See 05-17-31 AUTOMATIC TRANSAXLE (ATX) REMOVAL/INSTALLATION.) (See ATX Workshop Manual FN4A-EL (9999-95-FN4A-99).)</li> </ul>
6	<b>CHECK OPERATION OF EACH VALVE AND EACH SPRING</b> <ul style="list-style-type: none"> <li>• Turn ignition key to OFF.</li> <li>• Remove control valve body.</li> <li>• Disassemble control valve body.</li> <li>• Is each valve operation okay and is return spring okay? (See 05-17-36 CONTROL VALVE BODY REMOVAL/INSTALLATION.) (See ATX Workshop Manual FN4A-EL (9999-95-FN4A-99).)</li> </ul>	Yes	Replace ATX, then go to next step (See ATX Workshop Manual FN4A-EL (9999-95-FN4A-99).)
		No	Repair or replace shift valve and return spring, then go to next step. (See 05-17-36 CONTROL VALVE BODY REMOVAL/INSTALLATION.) (See ATX Workshop Manual FN4A-EL (9999-95-FN4A-99).)
7	<b>VERIFY TROUBLESHOOTING OF DTC P0772 COMPLETED</b> <ul style="list-style-type: none"> <li>• Make sure to reconnect all disconnected connectors.</li> <li>• Clear DTC from memory using WDS or equivalent.</li> <li>• Start engine.</li> <li>• Warm up ATX.</li> <li>• Drive the vehicle under the following conditions and make sure that gears shift smoothly from 1GR to 4GR.                             <ul style="list-style-type: none"> <li>— ATF temperature: <b>20 °C {68 °F} or above</b></li> <li>— Drive in D range</li> <li>— Vehicle speed (VSS PID): <b>below 70 km/h {43 mph}</b> (4th gear only)</li> </ul> </li> <li>• Is pending code present?</li> </ul>	Yes	Replace PCM, then go to next step. (See 01-40A-7 PCM REMOVAL/INSTALLATION [ZM].) (See 01-40B-7 PCM REMOVAL/INSTALLATION [FS].)
		No	Go to next step.
8	<b>VERIFY AFTER REPAIR PROCEDURE</b> <ul style="list-style-type: none"> <li>• Perform "After Repair Procedure". (See 05-02-6 AFTER REPAIR PROCEDURE.)</li> <li>• Are any DTCs present?</li> </ul>	Yes	Go to applicable DTC inspection.
		No	Troubleshooting completed.

05-02

# ON-BOARD DIAGNOSTIC

DTC P0773

A3U050201030W33

<b>DTC P0773</b>	<b>Shift solenoid E malfunction (electrical)</b>
<b>DETECTION CONDITION</b>	<ul style="list-style-type: none"> <li>• If PCM detects either of following conditions while driving in 4GR at D range with TCC operation, PCM determines that shift solenoid E circuit has a malfunction:                             <ul style="list-style-type: none"> <li>— Shift solenoid E voltage is stuck at <b>B+</b> after engine start.</li> <li>— Shift solenoid E voltage is stuck at <b>0 V</b> after engine start.</li> </ul> </li> </ul> <p><b>Diagnostic support note:</b></p> <ul style="list-style-type: none"> <li>• This is a continuous monitor (CCM).</li> <li>• MIL illuminates if PCM detects the above malfunction conditions during first drive cycle.</li> <li>• PENDING CODE is not available.</li> <li>• FREEZE FRAME DATA is available.</li> <li>• O/D OFF indicator light flashes.</li> <li>• DTC is stored in the PCM memory.</li> </ul>
<b>POSSIBLE CAUSE</b>	<ul style="list-style-type: none"> <li>• Shift solenoid E malfunction</li> <li>• Short to ground between ATX connector terminal F and PCM terminal 1</li> <li>• Short to power between ATX connector terminal F and PCM terminal 1</li> <li>• Open circuit between shift solenoid E terminal A and ATX connector terminal F</li> <li>• Open circuit between ATX connector terminal F and PCM terminal 1</li> <li>• Damaged connector between shift solenoid E and PCM</li> <li>• PCM malfunction</li> </ul>

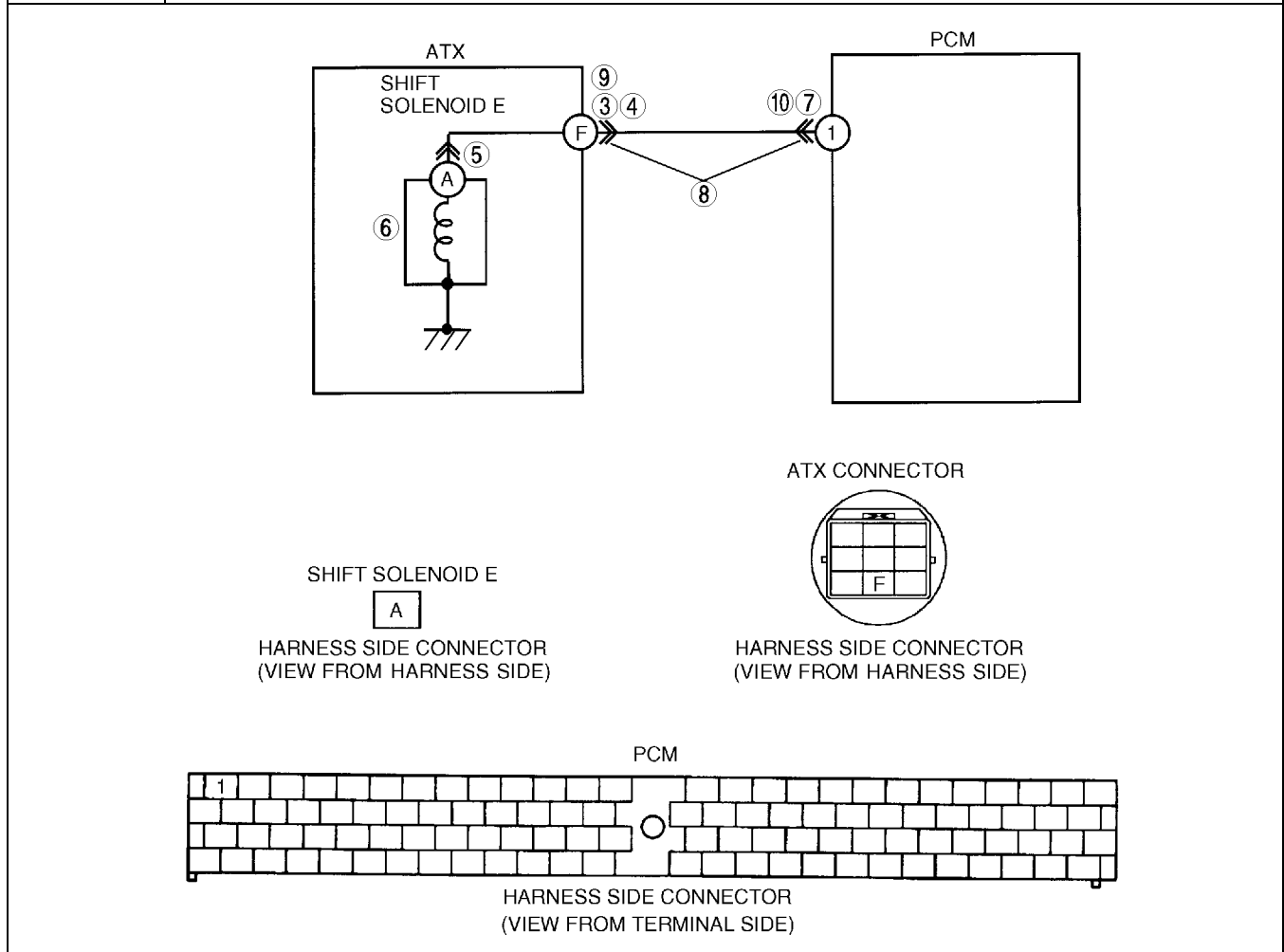

**Diagnostic procedure**

STEP	INSPECTION		ACTION
1	<b>VERIFY FREEZE FRAME DATA HAS BEEN RECORDED</b> <ul style="list-style-type: none"> <li>• Has FREEZE FRAME PID DATA been recorded?</li> </ul>	Yes	Go to next step.
		No	Record FREEZE FRAME PID DATA on repair order, then go to next step.
2	<b>VERIFY RELATED REPAIR INFORMATION AVAILABILITY</b> <ul style="list-style-type: none"> <li>• Check for related Service Bulletins availability.</li> <li>• Is any related repair information available?</li> </ul>	Yes	Perform repair or diagnosis according to available repair information. <ul style="list-style-type: none"> <li>• If vehicle is not repaired, go to next step.</li> </ul>
		No	Go to next step.

## ON-BOARD DIAGNOSTIC

STEP	INSPECTION	ACTION	
3	<b>INSPECT ATX CONNECTOR FOR POOR CONNECTION</b> <ul style="list-style-type: none"> <li>Turn ignition key to OFF.</li> <li>Disconnect ATX connector.</li> <li>Check for poor connection (damaged/pulled-out terminals, corrosion, etc.).</li> <li>Is connection okay?</li> </ul>	Yes	Go to next step.
		No	Repair or replace connector and/or terminals, then go to Step 11.
4	<b>INSPECT RESISTANCE</b> <ul style="list-style-type: none"> <li>Inspect resistance between ATX connector terminal F (transaxle case side) and body ground.</li> <li>Is resistance <b>within 10.9—26.2 ohms</b>? (See 05-17-28 Inspection of Resistance (On-vehicle).)</li> </ul>	Yes	Go to Step 7.
		No	Go to next step.
5	<b>INSPECT SHIFT SOLENOID E CONNECTOR FOR POOR CONNECTION</b> <ul style="list-style-type: none"> <li>Disconnect shift solenoid E connector.</li> <li>Check for poor connection (damaged/pulled-out terminals, corrosion, etc.).</li> <li>Is connection okay?</li> </ul>	Yes	Go to next step.
		No	Repair or replace connector and/or terminal, then go to Step 11.
6	<b>INSPECT RESISTANCE</b> <ul style="list-style-type: none"> <li>Inspect resistance between shift solenoid E terminal A (part-side) and body ground.</li> <li>Is resistance <b>within 10.9—26.2 ohms</b>? (See 05-17-29 Resistance Inspection (Off-vehicle).)</li> </ul>	Yes	Replace solenoid harness, then go to Step 11.
		No	Verify shift solenoid E installation. <ul style="list-style-type: none"> <li>If solenoid installed correctly, replace solenoid, then go to Step 11.</li> </ul> (See 05-17-30 SOLENOID VALVES REMOVAL/INSTALLATION.)
7	<b>INSPECT PCM CONNECTOR FOR POOR CONNECTION</b> <ul style="list-style-type: none"> <li>Disconnect PCM connector.</li> <li>Check for poor connection (damaged/pulled-out terminals, corrosion, etc.).</li> <li>Is connection okay?</li> </ul>	Yes	Go to next step.
		No	Repair or replace connector and/or terminals, then go to Step 11.
8	<b>INSPECT ATX CONNECTOR CIRCUIT FOR OPEN</b> <ul style="list-style-type: none"> <li>Inspect for continuity between PCM terminal 1 (harness-side) and ATX connector terminal F (vehicle harness-side).</li> <li>Is there continuity between terminals?</li> </ul>	Yes	Go to next step.
		No	Repair or replace harness, then go to Step 11.
9	<b>INSPECT ATX CONNECTOR CIRCUIT FOR SHORT TO POWER</b> <ul style="list-style-type: none"> <li>Turn ignition key to ON (engine OFF).</li> <li>Inspect voltage at ATX connector terminal F (vehicle harness-side).</li> <li>Is voltage <b>0 V</b>?</li> </ul>	Yes	Go to next step.
		No	Repair or replace harness, then go to Step 11.
10	<b>INSPECT PCM CIRCUIT FOR SHORT TO GROUND</b> <ul style="list-style-type: none"> <li>Turn ignition key to OFF.</li> <li>Inspect for continuity between PCM terminal 1 (harness-side) and body ground.</li> <li>Is there continuity?</li> </ul>	Yes	Repair or replace harness, then go to Step 11.
		No	Go to next step.
11	<b>VERIFY TROUBLESHOOTING OF DTC P0773 COMPLETED</b> <ul style="list-style-type: none"> <li>Make sure to reconnect all disconnected connectors.</li> <li>Clear DTC from memory using WDS or equivalent.</li> <li>Drive vehicle in D range and make sure that gears shift smoothly from 1GR to 4GR.</li> <li>Are any DTCs present?</li> </ul>	Yes	Replace PCM, then go to next step. (See 01-40A-7 PCM REMOVAL/INSTALLATION [ZM].) (See 01-40B-7 PCM REMOVAL/INSTALLATION [FS].)
		No	No concern is detected. Go to next step.
12	<b>VERIFY AFTER REPAIR PROCEDURE</b> <ul style="list-style-type: none"> <li>Perform "After Repair Procedure". (See 05-02-6 AFTER REPAIR PROCEDURE.)</li> <li>Are any DTCs present?</li> </ul>	Yes	Go to applicable DTC inspection.
		No	Troubleshooting completed.

05-02

# ON-BOARD DIAGNOSTIC

A3U050201030W34

## PID/DATA MONITOR INSPECTION

1. Connect the **SSTs** (WDS or equivalent) to the DLC-2.
2. Measure the PID value.

### Note

- Perform part inspection for the output device after PCM inspection.
- The PID/DATA MONITOR function monitors the calculated value of the input/output signals in the PCM. Therefore, if a monitored value of an output device is out of specification, it is necessary to inspect the monitored value of the input device related to the output device control. Since an output device malfunction is not directly indicated as a malfunction of the monitored value for the output device, it is necessary to inspect the output device individually using the simulation function, etc.

## PID/DATA MONITOR AND RECORD function table

Monitor item (Definition)	Unit/ Condition		Condition/Specification	Action	PCM terminal
GEAR	—		1GR: 1 2GR: 2 3GR: 3 4GR: 4	Inspect following PIDs: SSA/SS1, SSB/SS2, SSC/SS3, SSD/SS4, SSE/SS5	1, 27, 82, 99, 102
TFT (Transaxle fluid temperature)	°C		Indicates transaxle fluid temperature	Inspect TFT sensor. (See 05-17-25 TRANSAXLE FLUID TEMPERATURE (TFT) SENSOR INSPECTION.)	37
TFT V (Transaxle fluid signal voltage)	V		ATF 20 °C {68 °F}: 3.4—3.6 V ATF 130 °C {266 °F}: 0.4—0.5 V	Inspect TFT sensor. (See 05-17-25 TRANSAXLE FLUID TEMPERATURE (TFT) SENSOR INSPECTION.)	37
VPWR (Battery positive voltage)	V		Ignition switch ON: <b>B+</b> Engine running: <b>B+</b>	Inspect main relay. (See 09-21-5 RELAY INSPECTION.) Inspect battery. (See 01-17-1 BATTERY INSPECTION.)	71, 97
TROD (TR switch (D range))	ON/OFF		D range: ON Others: OFF	Inspect TR switch. (See 05-17-20 TRANSAXLE RANGE (TR) SWITCH INSPECTION.)	6
TRL (TR switch (1 range))	ON/OFF		1 range: ON Others: OFF	Inspect TR switch. (See 05-17-20 TRANSAXLE RANGE (TR) SWITCH INSPECTION.)	7
LPS (Pressure control solenoid)	A		ATF temperature at 60 °C {140 °F} Idle: <b>0.94—0.96 A</b> Stall (D range): <b>0.25—0.35 A</b> Stall (R range): <b>0—0.05 A</b>	Inspect pressure control solenoid. (See 05-17-28 SOLENOID VALVES INSPECTION.)	44, 81
LINEDES	kPa	inHg	Indicates target line pressure	Inspect following PIDs: TFT, TFT V, VPWR, TP, TSS, VSS, TROD, TRD, TRL, PNP	—
TCIL (O/D OFF indicator light)	ON/OFF		O/D OFF mode: ON Others: OFF	Inspect O/D OFF indicator light.	43
TCS (O/D OFF switch)	ON/OFF		O/D OFF switch pressed: ON O/D OFF switch released: OFF	Inspect O/D OFF switch. (See 05-17-19 O/D OFF SWITCH INSPECTION.)	29
TRR (TR switch (R position))	ON/OFF		R position: ON Others: OFF	Inspect TR switch. (See 05-17-20 TRANSAXLE RANGE (TR) SWITCH INSPECTION.)	32
TRD (TR switch (2 range))	ON/OFF		2 range: ON Others: OFF	Inspect TR switch. (See 05-17-20 TRANSAXLE RANGE (TR) SWITCH INSPECTION.)	9
SSA/SS1 (Shift solenoid A)	%		4GR: <b>99%</b> others: <b>0%</b>	Inspect shift solenoid A. (See 05-17-28 SOLENOID VALVES INSPECTION.)	82
SSB/SS2 (Shift solenoid B)	%		1GR at D range: <b>99%</b> Others: <b>0%</b>	Inspect shift solenoid B. (See 05-17-28 SOLENOID VALVES INSPECTION.)	99
SSC/SS3 (Shift solenoid C)	%		1GR/2GR: <b>99%</b> Others: <b>0%</b>	Inspect shift solenoid C. (See 05-17-28 SOLENOID VALVES INSPECTION.)	102



## ON-BOARD DIAGNOSTIC

Monitor item (Definition)	Unit/ Condition		Condition/Specification	Action	PCM terminal
SSD/ SS4 (Shift solenoid D)	ON/OFF		P or N position, 4GR, and 1GR at 1range: ON Others: OFF	Inspect shift solenoid D. (See 05-17-28 SOLENOID VALVES INSPECTION.)	27
SSE/SS5 (Shift solenoid E)	ON/OFF		4GR with TCC ON, and 1GR at 1range: ON Others: OFF	Inspect shift solenoid E. (See 05-17-28 SOLENOID VALVES INSPECTION.)	1
TPOD (Throttle position sensor)	%		CTP: <b>0%</b> WOT: <b>100%</b>	Inspect TP sensor. (See 01-40A-28 THROTTLE POSITION (TP) SENSOR INSPECTION [ZM].) (See 01-40B-29 THROTTLE POSITION (TP) SENSOR INSPECTION [FS].)	89
TP (Throttle position sensor signal voltage)	V		CTP: <b>0.4—1.5 V</b> WOT: <b>4.0—5.0 V</b>	Inspect TP sensor. (See 01-40A-28 THROTTLE POSITION (TP) SENSOR INSPECTION [ZM].) (See 01-40B-29 THROTTLE POSITION (TP) SENSOR INSPECTION [FS].)	89
PNP (TR switch)	ON/OFF		P position: ON N position: ON Others: OFF	Inspect TR switch. (See 05-17-20 TRANSAXLE RANGE (TR) SWITCH INSPECTION.)	64
TSS (Input/turbine speed)	RPM		Ignition switch ON: <b>0 rpm</b> Idle: <b>700—800 rpm</b> (P, N position) Indicates Input/turbine speed	Inspect input/turbine speed sensor. (See 05-17-26 INPUT/TURBINE SPEED SENSOR INSPECTION.)	23, 84
VSS (Vehicle speed)	KPH	MPH	Indicates vehicle speed	Inspect VSS. (See 05-17-27 VEHICLE SPEEDOMETER SENSOR (VSS) INSPECTION [ATX].)	58

05-02

**05-03 SYMPTOM TROUBLESHOOTING**

<b>AUTOMATIC TRANSAXLE SYSTEM</b>		<b>NO.15 ENGINE FLARES UP OR SLIPS</b>	
<b>WIRING DIAGRAM</b> .....	05-03-2	<b>WHEN ACCELERATING VEHICLE</b> . . . .	05-03-16
ZM Engine .....	05-03-2	<b>NO.16 JUDDER UPON TORQUE</b>	
FS Engine .....	05-03-4	<b>CONVERTER CLUTCH (TCC)</b>	
<b>FOREWORD</b> .....	05-03-6	<b>OPERATION</b> .....	
<b>AUTOMATIC TRANSAXLE BASIC</b>		<b>NO.17 EXCESSIVE SHIFT SHOCK</b>	
<b>INSPECTION</b> .....	05-03-6	<b>FROM N TO D OR N TO R</b>	
<b>AUTOMATIC TRANSAXLE SYMPTOM</b>		<b>POSITION/RANGE</b> .....	
<b>TROUBLESHOOTING ITEM TABLE</b> ..		05-03-17	
Quick Diagnosis Chart .....		05-03-9	
<b>NO.1 VEHICLE DOES NOT MOVE</b>		<b>NO.18 EXCESSIVE SHIFT SHOCK</b>	
<b>IN D, 2, 1 RANGES, OR IN</b>		<b>WHEN UPSHIFTING AND</b>	
<b>R POSITION</b> .....		<b>DOWNSHIFTING</b> .....	
05-03-11		05-03-17	
<b>NO.2 VEHICLE MOVES IN N POSITION</b>		<b>NO.19 EXCESSIVE SHIFT SHOCK</b>	
05-03-11		<b>ON TORQUE CONVERTER</b>	
<b>NO.3 VEHICLE MOVES IN P</b>		<b>CLUTCH (TCC)</b> .....	
<b>POSITION, OR PARKING GEAR</b>		05-03-17	
<b>DOES NOT DISENGAGE WHEN P</b>		<b>NO.20 NOISE OCCURS AT IDLE</b>	
<b>IS DISENGAGED</b> .....		<b>WHEN VEHICLE IS STOPPED IN</b>	
05-03-11		<b>ALL POSITIONS/RANGES</b> .....	
<b>NO.4 EXCESSIVE CREEP</b> .....		05-03-17	
05-03-11		<b>NO.21 NOISE OCCURS AT IDLE</b>	
<b>NO.5 NO CREEP AT ALL</b> .....		<b>WHEN VEHICLE IS STOPPED IN D,</b>	
05-03-12		<b>2, 1 RANGES, OR IN R POSITION</b> . . . .	
<b>NO.6 LOW MAXIMUM SPEED AND</b>		05-03-18	
<b>POOR ACCELERATION</b> .....		<b>NO.22 NO ENGINE BRAKING IN</b>	
05-03-12		<b>O/D OFF MODE</b> .....	
<b>NO.7 NO SHIFTING</b> .....		05-03-18	
05-03-13		<b>NO.23 TRANSAXLE OVERHEATS</b> . . . .	
<b>NO.8 DOES NOT SHIFT TO FOURTH</b>		05-03-19	
<b>GEAR (4GR)</b> .....		<b>NO.24 ENGINE STALLS WHEN</b>	
05-03-13		<b>SHIFTED TO D, 2, 1 RANGES, OR IN</b>	
<b>NO.9 ABNORMAL SHIFTING</b> .....		<b>R POSITION</b> .....	
05-03-14		05-03-19	
<b>NO.10 FREQUENT SHIFTING</b> .....		<b>NO.25 ENGINE STALLS WHEN DRIVING</b>	
05-03-14		<b>AT SLOW SPEED OR STOPPING</b> . . . .	
<b>NO.11 SHIFT POINT IS HIGH OR LOW</b>		05-03-19	
05-03-14		<b>NO.26 O/D OFF INDICATOR LIGHT</b>	
<b>NO.12 TORQUE CONVERTER</b>		<b>DOES NOT ILLUMINATE WHEN O/D</b>	
<b>CLUTCH (TCC) NON-OPERATION</b> ...		<b>OFF SWITCH IS TURNED TO ON</b> . . . .	
05-03-15		05-03-20	
<b>NO.13 NO KICKDOWN</b> .....		<b>NO.27 O/D OFF INDICATOR LIGHT</b>	
05-03-15		<b>ILLUMINATES WHEN O/D OFF</b>	
<b>NO.14 ENGINE FLARES UP OR</b>		<b>SWITCH IS NOT TURNED TO ON</b> .....	
<b>SLIPS WHEN UPSHIFTING OR</b>		05-03-20	
<b>DOWNSHIFTING</b> .....			
05-03-16			

05-03

# SYMPTOM TROUBLESHOOTING

## AUTOMATIC TRANSAXLE SYSTEM WIRING DIAGRAM

A3U050301030W01

ZM Engine

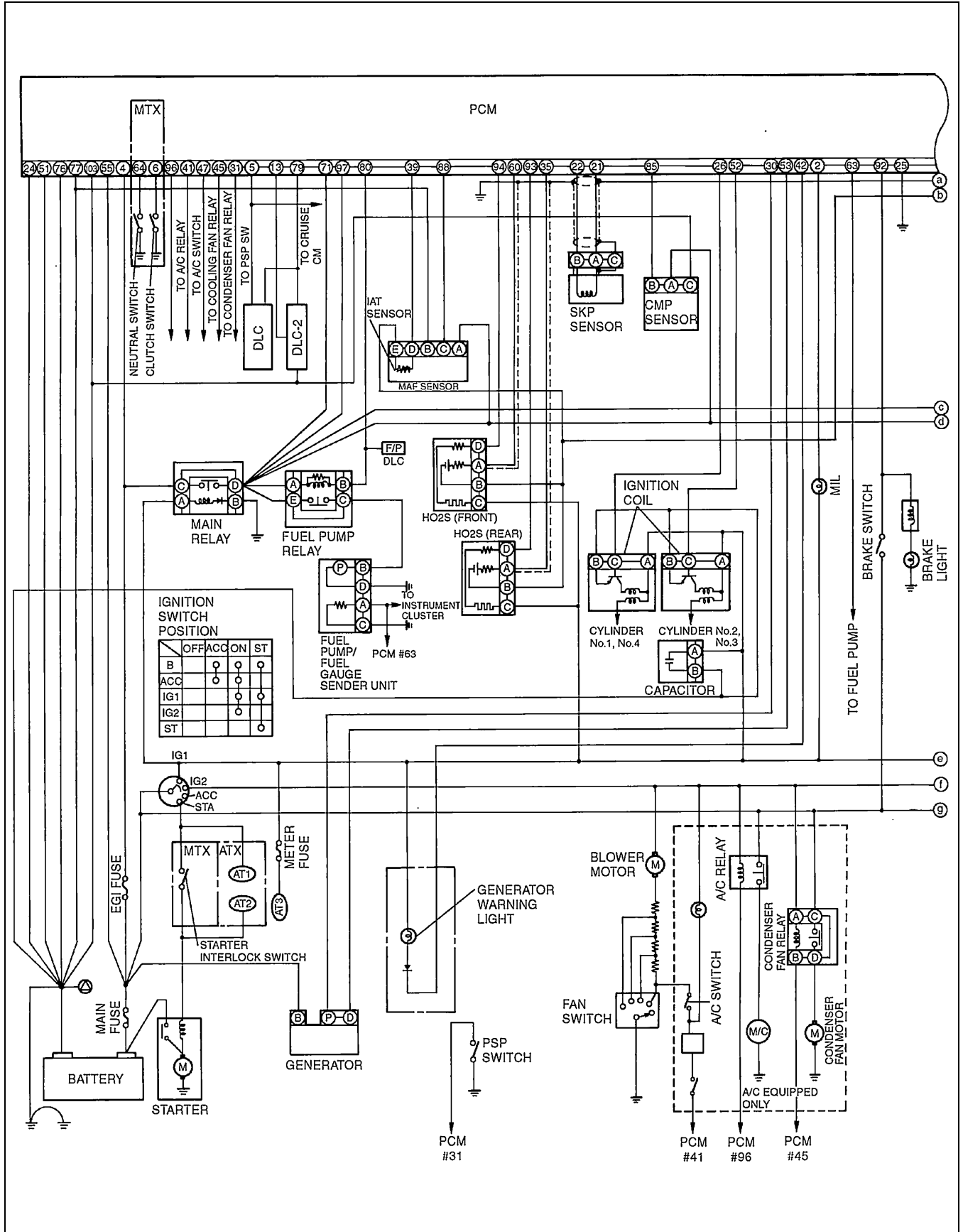

X3U501WA0

# SYMPTOM TROUBLESHOOTING

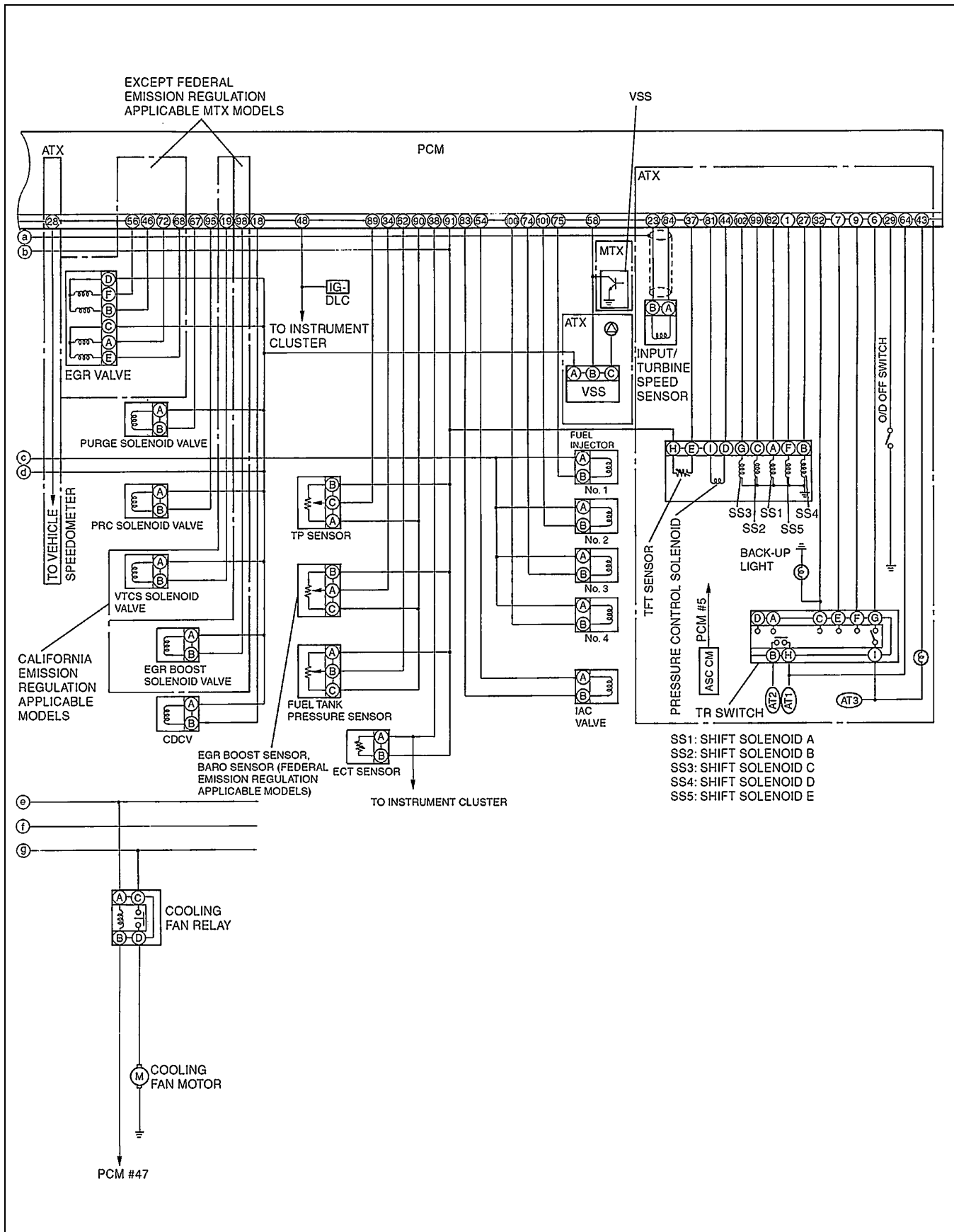

05-03

Y3U503WA0

# SYMPTOM TROUBLESHOOTING

## FS Engine

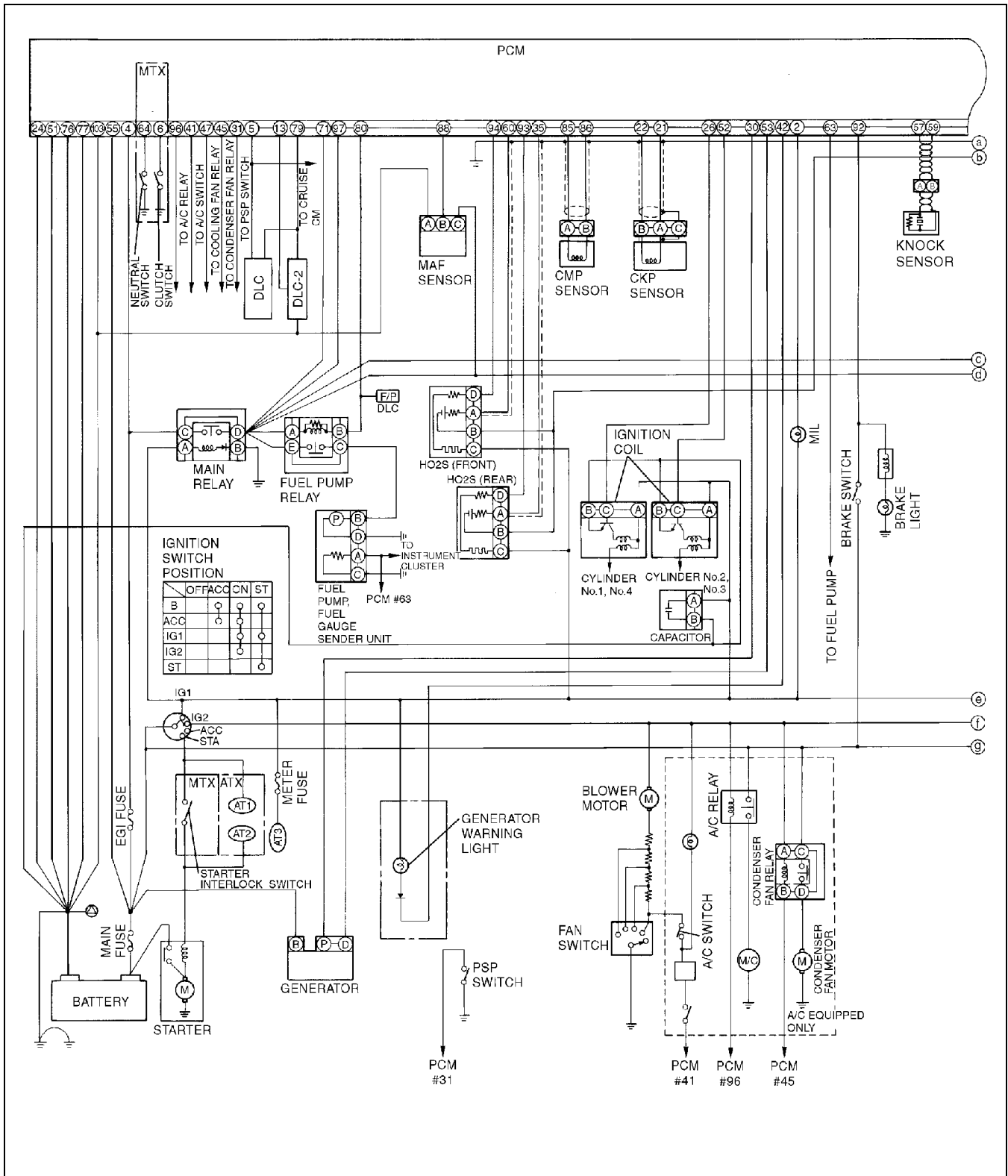

Z3U0140W103

# SYMPTOM TROUBLESHOOTING

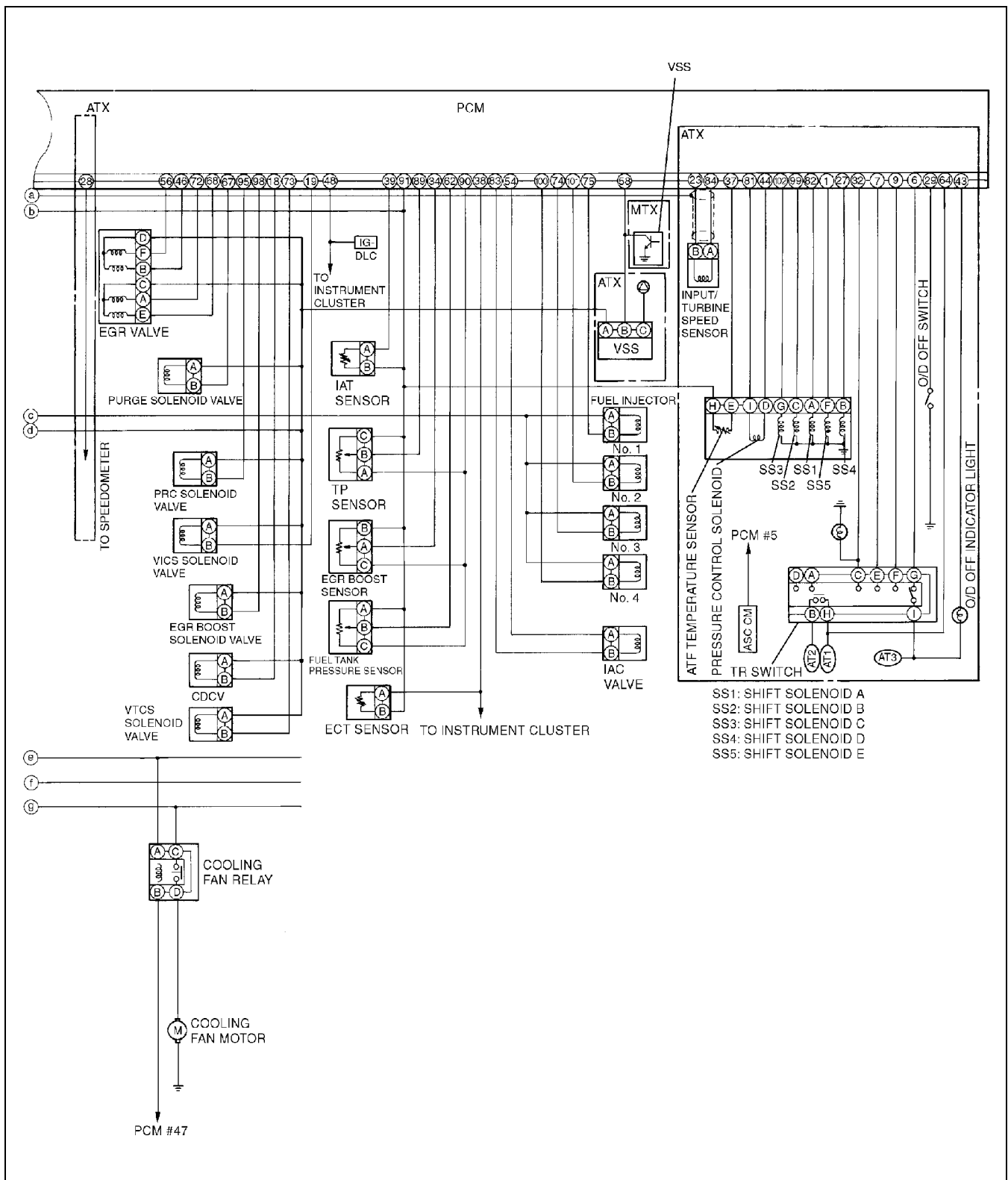

05-03

Z3U0140W104

# SYMPTOM TROUBLESHOOTING

## FOREWORD

A3U050301030W02

- When the customer reports a vehicle malfunction, check the malfunction indicator light (MIL) indication, O/D OFF indicator light flashing, and PCM memory for diagnostic trouble code (DTC), then diagnose the malfunction according to following flowchart.
  - If the DTC exists, diagnose the applicable DTC. (See 05-02-7 DTC TABLE.)
  - If the DTC does not exist and the MIL does not illuminate and no O/D OFF indicator light flashes, diagnose the applicable symptom troubleshooting. (See 05-03-7 AUTOMATIC TRANSAXLE SYMPTOM TROUBLESHOOTING ITEM TABLE.)

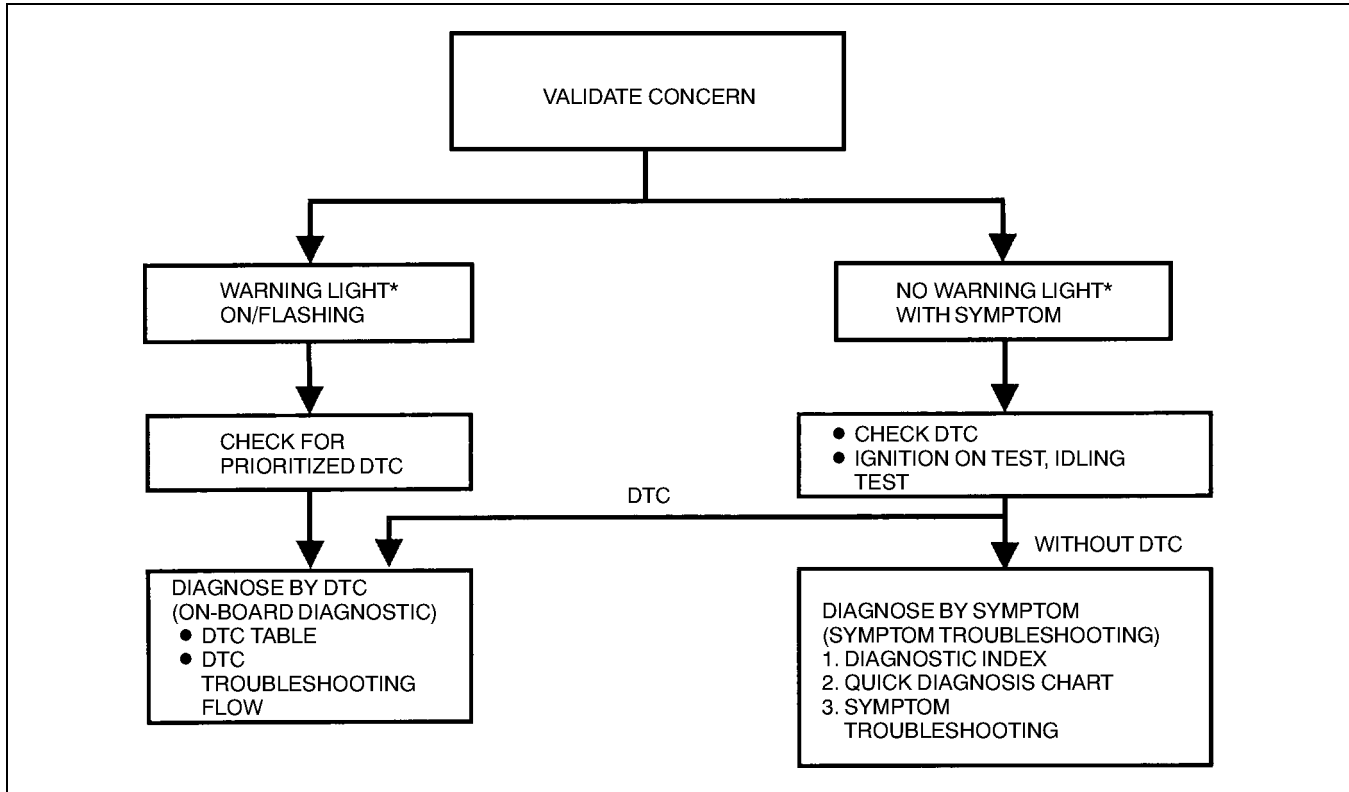

YMU102WBX

\* : Malfunction Indicator Light (MIL), O/D OFF indicator light

## AUTOMATIC TRANSAXLE BASIC INSPECTION

A3U050301030W03

STEP	INSPECTION		ACTION
1	<ul style="list-style-type: none"> <li>• Turn ignition switch on.</li> <li>• When selector lever is moved, is the selector illumination synchronized with the lever location? Also, when other ranges are selected from N or P during idling, does vehicle creep within <b>1 to 2 seconds</b>?</li> </ul>	Yes	Go to next step.
		No	Inspect selector lever and TR switch. Repair or replace defected areas. (See 05-18-2 SELECTOR LEVER INSPECTION.) (See 05-17-20 TRANSAXLE RANGE (TR) SWITCH INSPECTION.) If selector lever and TR switch are okay, go to next step.
2	<ul style="list-style-type: none"> <li>• Inspect ATF color and condition. (See 05-17-17 AUTOMATIC TRANSAXLE FLUID (ATF) INSPECTION.)</li> <li>• Are ATF color and odor normal?</li> </ul>	Yes	Go to next step.
		No	Repair or replace any defective parts according to inspection result. Flush automatic transaxle and cooler line as necessary.
3	<ul style="list-style-type: none"> <li>• Perform the line pressure test. (See 05-17-12 Line Pressure Test.)</li> <li>• Is line pressure okay?</li> </ul>	Yes	Go to next step.
		No	Adjust accelerator cable as necessary. Repair or replace any defective parts according to inspection result.
4	<ul style="list-style-type: none"> <li>• Perform the stall test. (See 05-17-13 Stall Test.)</li> <li>• Is stall speed okay?</li> </ul>	Yes	Go to next step.
		No	Repair or replace any defective parts according to inspection result.

## SYMPTOM TROUBLESHOOTING

STEP	INSPECTION	ACTION				
5	<ul style="list-style-type: none"> <li>Inspect the value at the following PIDs using the WDS or equivalent. (See 01-40A-7 PCM INSPECTION [ZM].) (See 01-40B-7 PCM INSPECTION [FS].) — TP, and VSS PIDs</li> <li>Is PID value okay?</li> </ul>	<table border="1" style="width: 100%; border-collapse: collapse;"> <tr> <td style="width: 50px; text-align: center;">Yes</td> <td>Perform symptom troubleshooting and follow procedures.</td> </tr> <tr> <td style="text-align: center;">No</td> <td>Repair or replace any defective parts according to inspection result.</td> </tr> </table>	Yes	Perform symptom troubleshooting and follow procedures.	No	Repair or replace any defective parts according to inspection result.
Yes	Perform symptom troubleshooting and follow procedures.					
No	Repair or replace any defective parts according to inspection result.					

### AUTOMATIC TRANSAXLE SYMPTOM TROUBLESHOOTING ITEM TABLE

A3U050301030W04

- Use the chart below to verify the symptoms of the trouble in order to diagnose the appropriate area.

No.	TROUBLESHOOTING ITEM	DESCRIPTION	PAGE
1	<ul style="list-style-type: none"> <li>Vehicle does not move in D, 2, 1 ranges, or in R position</li> </ul>	<ul style="list-style-type: none"> <li>Vehicle does not move when accelerator pedal is depressed.</li> </ul>	(See 05-03-11 NO.1 VEHICLE DOES NOT MOVE IN D, 2, 1 RANGES, OR IN R POSITION.)
2	<ul style="list-style-type: none"> <li>Vehicle moves in N position</li> </ul>	<ul style="list-style-type: none"> <li>Vehicle creeps in N position.</li> <li>Vehicle creeps if brake pedal is not depressed in N position.</li> </ul>	(See 05-03-11 NO.2 VEHICLE MOVES IN N POSITION.)
3	<ul style="list-style-type: none"> <li>Vehicle moves in P position, or parking gear does not disengage when P is disengaged</li> </ul>	<ul style="list-style-type: none"> <li>Vehicle rolls when on a downward slope and tires do not lock in P position.</li> <li>Tires are locked when P is disengaged. Vehicle does not move in D, 2, 1 ranges, and R position when accelerator pedal is depressed, and engine remains in stall condition.</li> </ul>	(See 05-03-11 NO.3 VEHICLE MOVES IN P POSITION, OR PARKING GEAR DOES NOT DISENGAGE WHEN P IS DISENGAGED.)
4	<ul style="list-style-type: none"> <li>Excessive creep</li> </ul>	<ul style="list-style-type: none"> <li>Vehicle accelerates in D, 2, 1 ranges, and R position without depressing accelerator pedal.</li> </ul>	(See 05-03-11 NO.4 EXCESSIVE CREEP.)
5	<ul style="list-style-type: none"> <li>No creep at all</li> </ul>	<ul style="list-style-type: none"> <li>Vehicle does not move in D, 2, 1 ranges, or R position when idling on flat paved road.</li> </ul>	(See 05-03-12 NO.5 NO CREEP AT ALL.)
6	<ul style="list-style-type: none"> <li>Low maximum speed and poor acceleration</li> </ul>	<ul style="list-style-type: none"> <li>Vehicle acceleration is poor at start.</li> <li>Delayed acceleration when accelerator pedal is depressed while driving.</li> </ul>	(See 05-03-12 NO.6 LOW MAXIMUM SPEED AND POOR ACCELERATION.)
7	<ul style="list-style-type: none"> <li>No shifting</li> </ul>	<ul style="list-style-type: none"> <li>Single shift range only.</li> <li>Sometimes it shifts correctly.</li> </ul>	(See 05-03-13 NO.7 NO SHIFTING.)
8	<ul style="list-style-type: none"> <li>Does not shift to fourth gear (4GR)</li> </ul>	<ul style="list-style-type: none"> <li>Vehicle does not upshift from 3GR to 4GR even though vehicle speed is increased.</li> <li>Vehicle does not shift to 4GR even though accelerator pedal is released in D range at <b>60 km/h {37 mph}</b>.</li> </ul>	(See 05-03-13 NO.8 DOES NOT SHIFT TO FOURTH GEAR (4GR).)
9	<ul style="list-style-type: none"> <li>Abnormal shifting</li> </ul>	<ul style="list-style-type: none"> <li>Shift incorrectly (incorrect shift pattern).</li> </ul>	(See 05-03-14 NO.9 ABNORMAL SHIFTING.)
10	<ul style="list-style-type: none"> <li>Frequent shifting</li> </ul>	<ul style="list-style-type: none"> <li>Downshifting occurs immediately even when accelerator pedal is depressed slightly in D, 2, 1 ranges except O/D OFF mode.</li> </ul>	(See 05-03-14 NO.10 FREQUENT SHIFTING.)
11	<ul style="list-style-type: none"> <li>Shift point is high or low</li> </ul>	<ul style="list-style-type: none"> <li>Shift point is considerably different from automatic shift diagram.</li> <li>Shift delayed when accelerating.</li> <li>Shift occurs quickly when accelerating and engine speed does not increase.</li> </ul>	(See 05-03-14 NO.11 SHIFT POINT IS HIGH OR LOW.)
12	<ul style="list-style-type: none"> <li>Torque converter clutch (TCC) non-operation</li> </ul>	<ul style="list-style-type: none"> <li>TCC does not operate when vehicle reaches TCC operation range.</li> </ul>	(See 05-03-15 NO.12 TORQUE CONVERTER CLUTCH (TCC) NON-OPERATION.)
13	<ul style="list-style-type: none"> <li>No kickdown</li> </ul>	<ul style="list-style-type: none"> <li>Does not downshift when accelerator pedal is fully depressed within kickdown range.</li> </ul>	(See 05-03-15 NO.13 NO KICKDOWN.)

05-03



## SYMPTOM TROUBLESHOOTING

No.	TROUBLESHOOTING ITEM	DESCRIPTION	PAGE
14	<ul style="list-style-type: none"> <li>Engine flares up or slips when upshifting or downshifting</li> </ul>	<ul style="list-style-type: none"> <li>When accelerator pedal is depressed at start, engine speed increases normally but vehicle speed increase slowly.</li> <li>When accelerator pedal is depressed while driving, engine speed increases but vehicle speed does not.</li> </ul>	(See 05-03-16 NO.14 ENGINE FLARES UP OR SLIPS WHEN UPSHIFTING OR DOWNSHIFTING.)
15	<ul style="list-style-type: none"> <li>Engine flares up or slips when accelerating vehicle</li> </ul>	<ul style="list-style-type: none"> <li>Engine flares up when accelerator pedal is depressed for upshifting.</li> <li>Engine flares up suddenly when accelerator pedal is depressed for downshifting.</li> </ul>	(See 05-03-16 NO.15 ENGINE FLARES UP OR SLIPS WHEN ACCELERATING VEHICLE.)
16	<ul style="list-style-type: none"> <li>Judder upon torque converter clutch (TCC) operation</li> </ul>	<ul style="list-style-type: none"> <li>Vehicle jolts when TCC is engaged.</li> </ul>	(See 05-03-16 NO.16 JUDDER UPON TORQUE CONVERTER CLUTCH (TCC) OPERATION.)
17	<ul style="list-style-type: none"> <li>Excessive shift shock from N to D or N to R position/range</li> </ul>	<ul style="list-style-type: none"> <li>Strong shock is felt when shifting from N to D or N to R position/range at idle.</li> </ul>	(See 05-03-17 NO.17 EXCESSIVE SHIFT SHOCK FROM N TO D OR N TO R POSITION/RANGE.)
18	<ul style="list-style-type: none"> <li>Excessive shift shock when upshifting and downshifting</li> </ul>	<ul style="list-style-type: none"> <li>Excessive shift shock is felt when depressing accelerator pedal to accelerate at upshifting. During cruising, excessive shift shock is felt when depressing accelerator pedal at downshifting.</li> </ul>	(See 05-03-17 NO.18 EXCESSIVE SHIFT SHOCK WHEN UPSHIFTING AND DOWNSHIFTING.)
19	<ul style="list-style-type: none"> <li>Excessive shift shock on torque converter clutch (TCC)</li> </ul>	<ul style="list-style-type: none"> <li>Strong shock is felt when TCC is engaged.</li> </ul>	(See 05-03-17 NO.19 EXCESSIVE SHIFT SHOCK ON TORQUE CONVERTER CLUTCH (TCC).)
20	<ul style="list-style-type: none"> <li>Noise occurs at idle when vehicle is stopped in all positions/ranges</li> </ul>	<ul style="list-style-type: none"> <li>Transaxle is noisy in all positions and ranges when vehicle is idling.</li> </ul>	(See 05-03-17 NO.20 NOISE OCCURS AT IDLE WHEN VEHICLE IS STOPPED IN ALL POSITIONS/RANGES.)
21	<ul style="list-style-type: none"> <li>Noise occurs at idle when vehicle is stopped in D, 2, 1 ranges, or in R position</li> </ul>	<ul style="list-style-type: none"> <li>Transaxle is noisy in driving ranges when vehicle is idling.</li> </ul>	(See 05-03-18 NO.21 NOISE OCCURS AT IDLE WHEN VEHICLE IS STOPPED IN D, 2, 1 RANGES, OR IN R POSITION.)
22	<ul style="list-style-type: none"> <li>No engine braking in O/D OFF mode</li> </ul>	<ul style="list-style-type: none"> <li>Engine speed drops to idle but vehicle coasts when accelerator pedal is released during cruising at medium to high speeds.</li> <li>Engine speed drops to idle but vehicle coasts when accelerator pedal is released when in 1 range at low vehicle speed.</li> </ul>	(See 05-03-18 NO.22 NO ENGINE BRAKING IN O/D OFF MODE.)
23	<ul style="list-style-type: none"> <li>Transaxle overheats</li> </ul>	<ul style="list-style-type: none"> <li>Burnt smell is emitted from transaxle.</li> <li>Smoke is emitted from transaxle.</li> </ul>	(See 05-03-19 NO.23 TRANSAXLE OVERHEATS.)
24	<ul style="list-style-type: none"> <li>Engine stalls when shifted to D, 2, 1 ranges, or in R position</li> </ul>	<ul style="list-style-type: none"> <li>Engine stalls when shifting from N or P position to D, 2, 1 ranges or R position at idle.</li> </ul>	(See 05-03-19 NO.24 ENGINE STALLS WHEN SHIFTED TO D, 2, 1 RANGES, OR IN R POSITION.)
25	<ul style="list-style-type: none"> <li>Engine stalls when driving at slow speed or stopping</li> </ul>	<ul style="list-style-type: none"> <li>Engine stalls when brake pedal is depressed while driving at low speed or stopping.</li> </ul>	(See 05-03-19 NO.25 ENGINE STALLS WHEN DRIVING AT SLOW SPEED OR STOPPING.)
26	<ul style="list-style-type: none"> <li>O/D OFF indicator light does not illuminate when O/D OFF switch is turned to on</li> </ul>	<ul style="list-style-type: none"> <li>O/D OFF indicator light in dashboard does not illuminate when O/D OFF switch is turned on and ignition switch at on.</li> </ul>	(See 05-03-20 NO.26 O/D OFF INDICATOR LIGHT DOES NOT ILLUMINATE WHEN O/D OFF SWITCH IS TURNED TO ON.)
27	<ul style="list-style-type: none"> <li>O/D OFF indicator light illuminates when O/D OFF switch is not turned to on</li> </ul>	<ul style="list-style-type: none"> <li>O/D OFF indicator light in dashboard illuminates even though O/D OFF switch is turned off and ignition switch at on.</li> </ul>	(See 05-03-20 NO.27 O/D OFF INDICATOR LIGHT ILLUMINATES WHEN O/D OFF SWITCH IS NOT TURNED TO ON.)



# SYMPTOM TROUBLESHOOTING

1	Vehicle does not move in D, 2, 1 ranges, or in R position				x			x	x						x	x	x	
2	Vehicle moves in N position									x								
3	Vehicle moves in P position, or parking gear does not disengage when P is disengaged																	
4	Excessive creep																	
5	No creep at all		x	x	x	x	x	x	x	x					x	x	x	
6	Low maximum speed and poor acceleration	x	x	x	x	x	x	x	x	x					x	x	x	x
7	No shifting			x	x	x	x	x	x	x					x	x		
8	Does not shift to fourth gear	x	x	x	x	x	x	x		x					x	x		
9	Abnormal shifting			x	x	x	x	x		x	x	x			x	x		
10	Frequent shifting									x					x			
11	Shift point is high or low																	
12	Torque converter clutch non-operation	x	x	x	x	x	x	x		x							x	x
13	No kickdown			x	x	x	x	x		x					x	x		
14	Engine flares up or slips when upshifting or downshifting		x	x	x	x	x	x	x	x					x	x		
15	Engine flares up or slips when accelerating vehicle		x							x	x				x	x		
16	Judder upon torque converter clutch operation									x							x	x
17	Excessive shift shock from N to D or N to R position/range		x							x	x	x	x		x	x		
18	Excessive shift shock when upshifting and downshifting	x	x	x	x	x	x	x	x	x	x	x			x	x		
19	Excessive shift shock on torque converter clutch		x			x				x							x	x
20	Noise occurs at idle when vehicle is stopped in all positions/ranges																	
21	Noise occurs at idle when vehicle is stopped in D, 2, 1 ranges, or in R position																	
22	No engine braking in O/D OFF mode									x					x	x		
23	Transaxle overheats	x	x							x				x				x
24	Engine stalls when shifted to D, 2, 1 ranges, or in R position									x							x	
25	Engine stalls when driving at slow speed or stopping									x							x	
26	O/D OFF indicator light does not illuminate when O/D OFF switch is turned to on																	
27	O/D OFF indicator light illuminates when O/D OFF switch is not turned to on																	
<b>No.</b>	<b>Item</b>	<b>Electrical system components</b>							<b>Hydraulic system components</b>				<b>Powertrain system</b>					
<b>Symptom</b>	<b>Cause of trouble</b>	<b>ATX outer parts</b>							<b>TFT sensor</b>	<b>Pressure control solenoid malfunction</b>	<b>Control valve is not operating properly</b>	<b>Forward accumulator is not operating properly</b>	<b>Servo apply accumulator is not operating properly</b>	<b>Oil cooler is not operating properly</b>	<b>Slipping (Brake, clutch)</b>	<b>Burnt (Brake, clutch)</b>	<b>Torque converter is not operating properly</b>	<b>TCC burnt</b>
		<b>Signal is not inputted</b>	<b>Malfunction signal is inputted</b>	<b>Shift solenoid D malfunction</b>	<b>Shift solenoid E malfunction</b>	<b>Shift solenoid A malfunction</b>	<b>Shift solenoid B malfunction</b>	<b>Shift solenoid C malfunction</b>										
<b>Inspection method</b>	<b>Item</b>																	
<b>Line pressure test</b>										x					x	x		
<b>Stall test</b>										x					x	x	x	
<b>Time lag test</b>											x	x			x	x		
<b>Diagnostic trouble code</b>		x		x	x	x	x	x										

# SYMPTOM TROUBLESHOOTING

## NO.1 VEHICLE DOES NOT MOVE IN D, 2, 1 RANGES, OR IN R POSITION

A3U050301030W05

<b>1</b>	<b>Vehicle does not move in D, 2, 1 ranges, or in R position</b>
<b>DESCRIPTION</b>	<ul style="list-style-type: none"> <li>• Vehicle does not move when accelerator pedal is depressed.</li> </ul>
<b>POSSIBLE CAUSE</b>	<ul style="list-style-type: none"> <li>• If the vehicle does not move in D, 2, 1 ranges or R position, basically, the malfunction is in the ATX. (Vehicle will move even with a malfunction in the PCM.) Since a malfunction in the sensor circuit or output circuit is the cause of the malfunction in the ATX, inspect the sensors, output circuit, and the related harnesses.               <ul style="list-style-type: none"> <li>a. Clutch slippage, worn (D, 2, 1 ranges - Forward clutch, R position - Reverse clutch, Low and reverse brake)                   <ul style="list-style-type: none"> <li>• Line pressure low</li> <li>• Sensor GND malfunction</li> <li>• Shift solenoid D malfunction</li> <li>• Shift solenoid E malfunction</li> <li>• Shift solenoid A malfunction</li> <li>• Shift solenoid B malfunction</li> <li>• Pressure control solenoid malfunction</li> <li>• Body GND malfunction</li> <li>• Control valve body malfunction</li> </ul> </li> <li>b. Selector lever malfunction</li> <li>c. Parking mechanism not operating properly</li> <li>d. Torque converter malfunction</li> </ul> </li> </ul>

05-03

## NO.2 VEHICLE MOVES IN N POSITION

A3U050301030W06

<b>2</b>	<b>Vehicle moves in N position</b>
<b>DESCRIPTION</b>	<ul style="list-style-type: none"> <li>• Vehicle creeps in N position.</li> <li>• Vehicle creeps if brake pedal is not depressed in N position.</li> </ul>
<b>POSSIBLE CAUSE</b>	<ul style="list-style-type: none"> <li>• If the vehicle moves in N position, basically, the malfunction is in the ATX. Since a malfunction in the sensor circuit or output circuit is the cause of the malfunction in the ATX, inspect the sensors, output circuit, and the related harnesses.               <ul style="list-style-type: none"> <li>a. Clutch burned (Forward clutch)                   <ul style="list-style-type: none"> <li>• Control valve body malfunction</li> </ul> </li> <li>b. Selector lever position disparity (Although the selector illumination shows N position, the hydraulic circuit shows D range or R position)</li> </ul> </li> </ul>

## NO.3 VEHICLE MOVES IN P POSITION, OR PARKING GEAR DOES NOT DISENGAGE WHEN P IS DISENGAGED

A3U050301030W07

<b>3</b>	<b>Vehicle moves in P position, or parking gear does not disengage when P is disengaged</b>
<b>DESCRIPTION</b>	<ul style="list-style-type: none"> <li>• Vehicle rolls when on a downward slope and tires do not lock in P position.</li> <li>• Tires are locked when P is disengaged. Vehicle does not move in D, 2, 1 ranges, and R position when accelerator pedal is depressed, and engine remains in stall condition.</li> </ul>
<b>POSSIBLE CAUSE</b>	<ul style="list-style-type: none"> <li>• Parking mechanism malfunction (May have effect on noise or shock from transaxle)</li> <li>• Improper adjustment of selector lever</li> <li>• If vehicle moves in N position, perform No.2 "Vehicle moves in N position"</li> </ul>

## NO.4 EXCESSIVE CREEP

A3U050301030W08

<b>4</b>	<b>Excessive creep</b>
<b>DESCRIPTION</b>	<ul style="list-style-type: none"> <li>• Vehicle accelerates in D, 2, 1 ranges, and R position without depressing accelerator pedal.</li> </ul>
<b>POSSIBLE CAUSE</b>	<ul style="list-style-type: none"> <li>• Engine idle speed high (transaxle system is not cause of problem)</li> <li>• Go to symptom troubleshooting No.8 "Fast idle/runs on". (See 01-03A-7 SYMPTOM DIAGNOSTIC INDEX [ZM].)</li> <li>• (See 01-03B-7 SYMPTOM DIAGNOSTIC INDEX [FS].)</li> </ul>

## SYMPTOM TROUBLESHOOTING

### NO.5 NO CREEP AT ALL

A3U050301030W09

<b>5</b>	<b>No creep at all</b>
<b>DESCRIPTION</b>	<ul style="list-style-type: none"> <li>• Vehicle does not move in D, 2, 1 ranges, or R position when idling on flat paved road.</li> </ul>
<b>POSSIBLE CAUSE</b>	<ul style="list-style-type: none"> <li>• Either the transaxle is stuck in 3GR or 4GR position, or there is clutch circuit slippage because the 3–4 clutch is stuck.                             <ul style="list-style-type: none"> <li>a. Clutch burned                                     <ul style="list-style-type: none"> <li>• Line pressure low</li> <li>• Shift solenoid D malfunction</li> <li>• Shift solenoid A malfunction</li> <li>• Shift solenoid B malfunction</li> <li>• Pressure control solenoid malfunction</li> <li>• Body GND malfunction</li> <li>• Control valve body malfunction</li> </ul> </li> <li>b. Transaxle fixed in 3GR (Operation of fail-safe function)                                     <ul style="list-style-type: none"> <li>• Short or open circuit in wiring</li> <li>• Poor connection of connector</li> <li>• Electronic parts of output and input system are malfunctioning</li> </ul> </li> <li>c. Engine torque is not produced                                     <ul style="list-style-type: none"> <li>• Torque converter is malfunctioning</li> </ul> </li> </ul> </li> </ul>

### NO.6 LOW MAXIMUM SPEED AND POOR ACCELERATION

A3U050301030W10

<b>6</b>	<b>Low maximum speed and poor acceleration</b>
<b>DESCRIPTION</b>	<ul style="list-style-type: none"> <li>• Vehicle acceleration is poor at start.</li> <li>• Delayed acceleration when accelerator pedal is depressed while driving.</li> </ul>
<b>POSSIBLE CAUSE</b>	<ul style="list-style-type: none"> <li>• If the clutch is stuck or does not stay in 3GR, the malfunction is in the engine circuit.                             <ul style="list-style-type: none"> <li>a. Clutch slippage, burned                                     <ul style="list-style-type: none"> <li>• Line pressure low</li> <li>• TP sensor malfunction</li> <li>• VSS malfunction</li> <li>• Input/turbine speed sensor malfunction</li> <li>• Sensor GND malfunction</li> <li>• Shift solenoid D malfunction</li> <li>• Shift solenoid E malfunction</li> <li>• Shift solenoid A malfunction</li> <li>• Shift solenoid B malfunction</li> <li>• Shift solenoid C malfunction</li> <li>• Pressure control solenoid malfunction</li> <li>• Body GND malfunction</li> <li>• Control valve body malfunction</li> </ul> </li> <li>b. Transaxle fixed in 3GR (Operation of fail-safe function)                                     <ul style="list-style-type: none"> <li>• Short or open circuit in wiring</li> <li>• Poor connection of connector</li> <li>• Electronic parts of output and input system are malfunctioning</li> </ul> </li> <li>c. Insufficient starting torque (Suspected when in-gear condition, shift control and engine circuit are normal)                                     <ul style="list-style-type: none"> <li>• Torque converter is malfunctioning (Poor operation, sticking)</li> </ul> </li> <li>d. Engagement of TCC operation range (Operation of fail-safe function)                                     <ul style="list-style-type: none"> <li>• TFT sensor malfunction (Short or open circuit)</li> </ul> </li> </ul> </li> </ul>

#### Diagnostic procedure

STEP	INSPECTION	ACTION				
1	<ul style="list-style-type: none"> <li>• Go to symptom troubleshooting No.11 "Lack/loss of power". (See 01–03A–7 SYMPTOM DIAGNOSTIC INDEX [ZM].)</li> <li>• (See 01–03B–7 SYMPTOM DIAGNOSTIC INDEX [FS].)</li> <li>• Is engine control system okay?</li> </ul>	<table border="0" style="width: 100%;"> <tr> <td style="text-align: center; vertical-align: middle;">Yes</td> <td style="padding-left: 10px;">Repeat basic inspection and repair or replace any defective parts according to inspection result. (See 05–03–6 AUTOMATIC TRANSAXLE BASIC INSPECTION.)</td> </tr> <tr> <td style="text-align: center; vertical-align: middle;">No</td> <td style="padding-left: 10px;">Repair or replace any defective parts according to inspection results.</td> </tr> </table>	Yes	Repeat basic inspection and repair or replace any defective parts according to inspection result. (See 05–03–6 AUTOMATIC TRANSAXLE BASIC INSPECTION.)	No	Repair or replace any defective parts according to inspection results.
Yes	Repeat basic inspection and repair or replace any defective parts according to inspection result. (See 05–03–6 AUTOMATIC TRANSAXLE BASIC INSPECTION.)					
No	Repair or replace any defective parts according to inspection results.					

#### Note

- If malfunction remains, inspect related Service Bulletins and perform repair or diagnosis.
- If vehicle is repaired, troubleshooting is completed.
- If vehicle is not repaired or additional diagnostic information is not available, replace PCM.

# SYMPTOM TROUBLESHOOTING

## NO.7 NO SHIFTING

A3U050301030W11

<b>7</b>	<b>No shifting</b>
<b>DESCRIPTION</b>	<ul style="list-style-type: none"> <li>• Single shift range only.</li> <li>• Sometimes it shifts correctly.</li> </ul>
<b>POSSIBLE CAUSE</b>	<ul style="list-style-type: none"> <li>• When the gear position is fixed in 3GR due to the fail-safe operation, the malfunction is in the ATX.</li> <li>• Perform malfunction diagnosis according to No.6 “Low maximum speed and poor acceleration”.             <ul style="list-style-type: none"> <li>a. Clutch burned                 <ul style="list-style-type: none"> <li>• Line pressure low</li> <li>• VSS malfunction</li> <li>• Input/turbine speed sensor malfunction</li> <li>• Sensor GND malfunction</li> <li>• Shift solenoid D malfunction</li> <li>• Shift solenoid E malfunction</li> <li>• Shift solenoid A malfunction</li> <li>• Shift solenoid B malfunction</li> <li>• Shift solenoid C malfunction</li> <li>• Pressure control solenoid malfunction</li> <li>• Body GND malfunction</li> <li>• Control valve body malfunction</li> </ul> </li> <li>b. Transaxle fixed in 3GR (Operation in fail-safe function)                 <ul style="list-style-type: none"> <li>• Short or open circuit in wiring</li> <li>• Poor connection of connector</li> <li>• Disconnected shift solenoid connector</li> <li>• Poor GND of shift solenoid</li> </ul> </li> </ul> </li> </ul>

05-03

## NO.8 DOES NOT SHIFT TO FOURTH GEAR (4GR)

A3U050301030W12

<b>8</b>	<b>Does not shift to fourth gear (4GR)</b>
<b>DESCRIPTION</b>	<ul style="list-style-type: none"> <li>• Vehicle does not upshift from 3GR to 4GR even though vehicle speed is increased.</li> <li>• Vehicle does not shift to 4GR even though accelerator pedal is released in D range at <b>60 km/h {37 mph}</b>.</li> </ul>
<b>POSSIBLE CAUSE</b>	<ul style="list-style-type: none"> <li>• Basically, the TCC does not operate when the fail-safe is operating. Verify the DTC first. If the TCC operates when driving at high speeds only, the malfunction (improper adjustment) is in the O/D OFF switch circuit or TR switch circuit.             <ul style="list-style-type: none"> <li><b>Caution</b> <ul style="list-style-type: none"> <li>• <b>If the TCC is stuck, inspect it. In addition, inspect the oil cooler for foreign particles which may have mixed in with the ATF.</b></li> </ul> </li> <li>a. TCC slippage, burned                 <ul style="list-style-type: none"> <li>• Line pressure low</li> <li>• TP sensor malfunction</li> <li>• ECT sensor malfunction</li> <li>• VSS malfunction</li> <li>• Input/turbine speed sensor malfunction</li> <li>• Sensor GND malfunction</li> </ul> </li> <li>b. TFT sensor malfunction                 <ul style="list-style-type: none"> <li>• Short or open circuit in wiring</li> <li>• Poor connection of connector</li> <li>• Sensor malfunction</li> </ul> </li> <li>c. TR switch malfunction                 <ul style="list-style-type: none"> <li>• Short or open circuit in wiring</li> <li>• Poor connection of connector</li> <li>• Sensor malfunction</li> <li>• Selector lever adjustment incorrect</li> <li>• TR switch adjustment incorrect</li> </ul> </li> <li>d. Shift solenoid A, shift solenoid E malfunction                 <ul style="list-style-type: none"> <li>• Short or open circuit in wiring</li> <li>• Poor connection of connector</li> <li>• Solenoid valve stuck</li> </ul> </li> <li>e. O/D OFF switch malfunction</li> <li>f. Torque converter malfunction</li> <li>g. Control valve body malfunction</li> </ul> </li> </ul>

# SYMPTOM TROUBLESHOOTING

## NO.9 ABNORMAL SHIFTING

A3U050301030W13

<b>9</b>	<b>Abnormal shifting</b>
<b>DESCRIPTION</b>	<ul style="list-style-type: none"> <li>• Shift incorrectly (incorrect shift pattern).</li> </ul>
<b>POSSIBLE CAUSE</b>	<ul style="list-style-type: none"> <li>• There is a malfunction in the signal circuit which controls shifting (TP sensor, input/turbine speed sensor, VSS), the control valve is stuck, the accumulator (forward or servo apply) is stuck, or the clutch circuit is stuck.             <ul style="list-style-type: none"> <li>a. Clutch slippage, burned                 <ul style="list-style-type: none"> <li>• Line pressure low</li> <li>• TP sensor malfunction or misadjustment</li> <li>• VSS malfunction</li> <li>• Input/turbine speed sensor malfunction</li> <li>• Sensor GND malfunction</li> <li>• Shift solenoid D malfunction</li> <li>• Shift solenoid E malfunction</li> <li>• Shift solenoid A malfunction</li> <li>• Shift solenoid B malfunction</li> <li>• Shift solenoid C malfunction</li> <li>• Body GND malfunction</li> <li>• Accelerator cable misadjustment</li> <li>• Control valve body malfunction</li> </ul> </li> </ul> </li> </ul>

## NO.10 FREQUENT SHIFTING

A3U050301030W14

<b>10</b>	<b>Frequent shifting</b>
<b>DESCRIPTION</b>	<ul style="list-style-type: none"> <li>• Downshifting occurs immediately even when accelerator pedal is depressed slightly in D, 2, 1 ranges except O/D OFF mode.</li> </ul>
<b>POSSIBLE CAUSE</b>	<ul style="list-style-type: none"> <li>• The circuit which is the cause is basically the same as for No.9 "Abnormal shifting". However, a malfunction of the input signal to the TP sensor, input/turbine speed sensor, VSS (including the sensor GND, sensor harness and connector), or clutch slippage (clutch stuck, low pressure in line) may also be the cause.</li> </ul>

## NO.11 SHIFT POINT IS HIGH OR LOW

A3U050301030W15

<b>11</b>	<b>Shift point is high or low</b>
<b>DESCRIPTION</b>	<ul style="list-style-type: none"> <li>• Shift point is considerably different from automatic shift diagram.</li> <li>• Shift delays when accelerating.</li> <li>• Shift occurs quickly when accelerating and engine speed does not increase.</li> </ul>
<b>POSSIBLE CAUSE</b>	<ul style="list-style-type: none"> <li>• If the transaxle shift abnormal, there is a malfunction of the input signal to the TP sensor, input/turbine speed sensor, or VSS.</li> <li>• If the engine speed is high or low regardless that shifting is normal, inspect the tachometer.</li> <li>• Verify that the output signal of the TP sensor changes linearly.</li> </ul>

# SYMPTOM TROUBLESHOOTING

## NO.12 TORQUE CONVERTER CLUTCH (TCC) NON-OPERATION

A3U050301030W16

<b>12</b>	<b>Torque converter clutch (TCC) non-operation</b>
<b>DESCRIPTION</b>	<ul style="list-style-type: none"> <li>• TCC does not operate when vehicle reaches TCC operation range.</li> </ul>
<b>POSSIBLE CAUSE</b>	<ul style="list-style-type: none"> <li>• Basically, the TCC does not operate when the fail-safe is operating. Verify the DTC first. If the TCC operates when driving at high speeds only, the malfunction (improper adjustment) is in the O/D OFF switch circuit or TR switch circuit.</li> <li><b>Caution</b> <ul style="list-style-type: none"> <li>• <b>If the TCC is stuck, inspect it. In addition, inspect the oil cooler for foreign particles which may have mixed in with the ATF.</b></li> </ul> </li> <li>a. TCC burned                             <ul style="list-style-type: none"> <li>• TP sensor malfunction</li> <li>• TFT sensor malfunction</li> <li>• VSS malfunction</li> <li>• Input/turbine speed sensor malfunction</li> <li>• Sensor GND malfunction</li> <li>• Shift solenoid D malfunction (Sticking)</li> <li>• Shift solenoid E malfunction (Sticking)</li> <li>• Shift solenoid A malfunction (Sticking)</li> <li>• Shift solenoid B malfunction (Sticking)</li> <li>• Shift solenoid C malfunction (Sticking)</li> <li>• TCC hydraulic pressure system (Poor operation, sticking)</li> </ul> </li> <li>b. TP sensor malfunction (Not operating linearly)</li> <li>c. Input/turbine speed sensor or VSS malfunction</li> </ul>

05-03

### Diagnostic procedure

STEP	INSPECTION		ACTION
1	<ul style="list-style-type: none"> <li>• Remove torque converter.</li> <li>• Inspect torque converter. (See ATX Workshop Manual.)</li> <li>• Is torque converter okay?</li> </ul>	Yes	Repeat basic inspection and repair or replace any defective parts according to inspection result. (See 05-03-6 AUTOMATIC TRANSAXLE BASIC INSPECTION.)
		No	Replace torque converter.

#### Note

- If malfunction remains, inspect related Service Bulletins and perform repair or diagnosis.
- If vehicle is repaired, troubleshooting is completed.
- If vehicle is not repaired or additional diagnostic information is not available, replace PCM.

## NO.13 NO KICKDOWN

A3U050301030W17

<b>13</b>	<b>No kickdown</b>
<b>DESCRIPTION</b>	<ul style="list-style-type: none"> <li>• Does not downshift when accelerator pedal is fully depressed within kickdown range.</li> </ul>
<b>POSSIBLE CAUSE</b>	<ul style="list-style-type: none"> <li>• If the transaxle does not downshift though shifting is normal, the malfunction is in the TP sensor circuit (including the sensor GND, sensor harness and connector).</li> </ul>



## SYMPTOM TROUBLESHOOTING

### NO.14 ENGINE FLARES UP OR SLIPS WHEN UPSHIFTING OR DOWNSHIFTING

A3U050301030W18

<b>14</b>	<b>Engine flares up or slips when upshifting or downshifting</b>
<b>DESCRIPTION</b>	<ul style="list-style-type: none"> <li>• When accelerator pedal is depressed at start, engine speed increases normally but vehicle speed increase slowly.</li> <li>• When accelerator pedal is depressed while driving, engine speed increases but vehicle speed does not.</li> </ul>
<b>POSSIBLE CAUSE</b>	<ul style="list-style-type: none"> <li>• There is clutch slip because the clutch is stuck or the line pressure is low.               <ul style="list-style-type: none"> <li>a. Clutch stuck, slippage (forward clutch, 3–4 clutch, low and reverse brake, 2–4 brake band, one-way clutch)                   <ul style="list-style-type: none"> <li>• Line pressure low</li> <li>• TP sensor malfunction or misadjustment</li> <li>• VSS malfunction</li> <li>• Input/turbine speed sensor malfunction</li> <li>• Sensor GND malfunction</li> <li>• Shift solenoid D malfunction</li> <li>• Shift solenoid E malfunction</li> <li>• Shift solenoid A malfunction</li> <li>• Shift solenoid B malfunction</li> <li>• Shift solenoid C malfunction</li> <li>• Pressure control solenoid malfunction</li> <li>• Body GND malfunction</li> <li>• Accelerator cable misadjustment</li> <li>• Control valve body malfunction</li> </ul> </li> <li>b. Poor operation of mechanical pressure                   <ul style="list-style-type: none"> <li>• Selector lever position disparity</li> <li>• TR switch position disparity</li> </ul> </li> </ul> </li> </ul>

### NO.15 ENGINE FLARES UP OR SLIPS WHEN ACCELERATING VEHICLE

A3U050301030W19

<b>15</b>	<b>Engine flares up or slips when accelerating vehicle</b>
<b>DESCRIPTION</b>	<ul style="list-style-type: none"> <li>• Engine flares up when accelerator pedal is depressed for upshifting.</li> <li>• Engine flares up suddenly when accelerator pedal is depressed for downshifting.</li> </ul>
<b>POSSIBLE CAUSE</b>	<ul style="list-style-type: none"> <li>• The malfunction is basically the same as for No.14 “Engine flares up or slips when upshifting or downshifting”. — If conditions for No.14 worsen, the malfunction will develop to No.15.</li> </ul>

### NO.16 JUDDER UPON TORQUE CONVERTER CLUTCH (TCC) OPERATION

A3U050301030W20

<b>16</b>	<b>Judder upon torque converter clutch (TCC) operation</b>
<b>DESCRIPTION</b>	<ul style="list-style-type: none"> <li>• Vehicle jolts when TCC is engaged.</li> </ul>
<b>POSSIBLE CAUSE</b>	<ul style="list-style-type: none"> <li>• Poor TCC engagement due to either slippage because the TCC is stuck or the line pressure is low.           <ul style="list-style-type: none"> <li><b>Caution</b> <ul style="list-style-type: none"> <li>• <b>If the TCC is stuck, inspect it. In addition, inspect the oil cooler for foreign particles which may have mixed in with the ATF.</b></li> </ul> </li> <li>a. TCC piston slippage, burned               <ul style="list-style-type: none"> <li>• Line pressure low</li> <li>• TP sensor malfunction or misadjustment</li> <li>• VSS malfunction</li> <li>• Input/turbine speed sensor malfunction</li> <li>• Shift solenoid A malfunction</li> <li>• Control valve body malfunction</li> </ul> </li> <li>b. Torque converter malfunction</li> </ul> </li> </ul>

# SYMPTOM TROUBLESHOOTING

## NO.17 EXCESSIVE SHIFT SHOCK FROM N TO D OR N TO R POSITION/RANGE

A3U050301030W21

<b>17</b>	<b>Excessive shift shock from N to D or N to R position/range</b>
<b>DESCRIPTION</b>	<ul style="list-style-type: none"> <li>• Strong shock is felt when shifting from N to D or N to R position/range at idle.</li> </ul>
<b>POSSIBLE CAUSE</b>	<ul style="list-style-type: none"> <li>• Shift shock may worsen when the fail-safe is operating. If no DTC is output, the shift shock may worsen due to poor operation of the control valve body or sticking of the clutch.               <ol style="list-style-type: none"> <li>a. Clutch burned (N→D: Forward clutch, N→R: Reverse clutch or low and reverse brake)                   <ul style="list-style-type: none"> <li>• Line pressure low</li> <li>• TP sensor malfunction</li> <li>• VSS malfunction</li> <li>• Input/turbine speed sensor malfunction</li> <li>• Accelerator cable misadjustment</li> <li>• Control valve body malfunction</li> </ul> </li> <li>b. Poor hydraulic operation (Malfunction in range change)                   <ul style="list-style-type: none"> <li>• Servo apply accumulator malfunction</li> </ul> </li> <li>c. Idle speed high</li> <li>d. Poor tightening torque of engine mount and/or exhaust mount</li> </ol> </li> </ul>

## NO.18 EXCESSIVE SHIFT SHOCK WHEN UPSHIFTING AND DOWNSHIFTING

A3U050301030W22

05-03

<b>18</b>	<b>Excessive shift shock when upshifting and downshifting</b>
<b>DESCRIPTION</b>	<ul style="list-style-type: none"> <li>• Excessive shift shock is felt when depressing accelerator pedal to accelerate at upshifting. During cruising, excessive shift shock is felt when depressing accelerator pedal at downshifting.</li> </ul>
<b>POSSIBLE CAUSE</b>	<ul style="list-style-type: none"> <li>• Shift shock may worsen when the fail-safe is operating. The shift shock may also worsen if the TP sensor, input/turbine speed sensor, or VSS signal malfunctions.               <ol style="list-style-type: none"> <li>a. Clutch slippage, burned (2-4 brake band, 3-4 clutch)                   <ul style="list-style-type: none"> <li>• Line pressure low, high</li> <li>• TP sensor malfunction</li> <li>• VSS malfunction</li> <li>• Input/turbine speed sensor malfunction</li> <li>• TFT sensor malfunction</li> <li>• Shift solenoid D malfunction</li> <li>• Shift solenoid E malfunction</li> <li>• Shift solenoid A malfunction</li> <li>• Shift solenoid B malfunction</li> <li>• Shift solenoid C malfunction</li> <li>• Pressure control solenoid malfunction</li> <li>• Accelerator cable misadjustment</li> <li>• Control valve body malfunction</li> </ul> </li> <li>b. Poor hydraulic operation (Malfunction in range change)                   <ul style="list-style-type: none"> <li>• Forward accumulator malfunction</li> <li>• Servo apply accumulator malfunction</li> </ul> </li> </ol> </li> </ul>

## NO.19 EXCESSIVE SHIFT SHOCK ON TORQUE CONVERTER CLUTCH (TCC)

A3U050301030W23

<b>19</b>	<b>Excessive shift shock on torque converter clutch (TCC)</b>
<b>DESCRIPTION</b>	<ul style="list-style-type: none"> <li>• Strong shock is felt when TCC is engaged.</li> </ul>
<b>POSSIBLE CAUSE</b>	<ul style="list-style-type: none"> <li>• The troubleshooting flow is the same as for No.16 "Judder (Intense vibration) upon torque converter clutch (TCC) operation".</li> </ul>

## NO.20 NOISE OCCURS AT IDLE WHEN VEHICLE IS STOPPED IN ALL POSITIONS/RANGES

A3U050301030W24

<b>20</b>	<b>Noise occurs at idle when vehicle is stopped in all positions/ranges</b>
<b>DESCRIPTION</b>	<ul style="list-style-type: none"> <li>• Transaxle is noisy in all positions and ranges when vehicle is idling.</li> </ul>
<b>POSSIBLE CAUSE</b>	<ul style="list-style-type: none"> <li>• The malfunction is in the oil pump which causes a high-pitched noise to be emitted from the transaxle at idle.               <p><b>Note</b></p> <ul style="list-style-type: none"> <li>• If a noise is emitted during shifting only, the malfunction is in shift solenoid D, E or duty solenoid valves.</li> <li>• If a noise is emitted during shifting at certain gears only or during deceleration only, it is gear noise.</li> </ul> </li> </ul>

## SYMPTOM TROUBLESHOOTING

### Diagnostic procedure

STEP	INSPECTION	ACTION				
1	<ul style="list-style-type: none"> <li>• Inspect engine condition.</li> <li>• Is there engine concern (i.e. rough idle)?</li> </ul>	<table border="0" style="width: 100%;"> <tr> <td style="text-align: center; vertical-align: top; width: 50px;">Yes</td> <td>Go to appropriate symptom troubleshooting. (See 01-03A-7 SYMPTOM DIAGNOSTIC INDEX [ZM].) (See 01-03B-7 SYMPTOM DIAGNOSTIC INDEX [FS].)</td> </tr> <tr> <td style="text-align: center; vertical-align: top;">No</td> <td>Repeat basic inspection and repair or replace any defective parts according to inspection result. (See 05-03-6 AUTOMATIC TRANSAXLE BASIC INSPECTION.)</td> </tr> </table>	Yes	Go to appropriate symptom troubleshooting. (See 01-03A-7 SYMPTOM DIAGNOSTIC INDEX [ZM].) (See 01-03B-7 SYMPTOM DIAGNOSTIC INDEX [FS].)	No	Repeat basic inspection and repair or replace any defective parts according to inspection result. (See 05-03-6 AUTOMATIC TRANSAXLE BASIC INSPECTION.)
Yes	Go to appropriate symptom troubleshooting. (See 01-03A-7 SYMPTOM DIAGNOSTIC INDEX [ZM].) (See 01-03B-7 SYMPTOM DIAGNOSTIC INDEX [FS].)					
No	Repeat basic inspection and repair or replace any defective parts according to inspection result. (See 05-03-6 AUTOMATIC TRANSAXLE BASIC INSPECTION.)					

#### Note

- If malfunction remains, inspect related Service Bulletins and perform repair or diagnosis.
- If vehicle is repaired, troubleshooting is completed.
- If vehicle is not repaired or additional diagnostic information is not available, replace PCM.

### NO.21 NOISE OCCURS AT IDLE WHEN VEHICLE IS STOPPED IN D, 2, 1 RANGES, OR IN R POSITION

A3U050301030W25

<b>21</b>	<b>Noise occurs at idle when vehicle is stopped in D, 2, 1 ranges, or in R position</b>
<b>DESCRIPTION</b>	<ul style="list-style-type: none"> <li>• Transaxle is noisy in driving ranges when vehicle is idling.</li> </ul>
<b>POSSIBLE CAUSE</b>	<ul style="list-style-type: none"> <li>• Although the malfunction is basically the same as No.20 "Noise occurs at idle when vehicle is stopped in all positions/ranges", other causes may be selector lever or TR switch not adjusted properly.</li> </ul>

### NO.22 NO ENGINE BRAKING IN O/D OFF MODE

A3U050301030W26

<b>22</b>	<b>No engine braking in O/D OFF mode</b>
<b>DESCRIPTION</b>	<ul style="list-style-type: none"> <li>• Engine speed drops to idle but vehicle coasts when accelerator pedal is released during cruising at medium to high speeds.</li> <li>• Engine speed drops to idle but vehicle coasts when accelerator pedal is released when in 1 range at low vehicle speed.</li> </ul>
<b>POSSIBLE CAUSE</b>	<p>a. Clutch slippage, or burned (low and reverse brake)</p> <ul style="list-style-type: none"> <li>• Line pressure low</li> <li>• VSS malfunction</li> <li>• Input/turbine speed sensor malfunction</li> <li>• TP sensor malfunction</li> <li>• Control valve body malfunction</li> </ul> <p>b. O/D OFF switch on but not recognized by PCM (short, or open circuit, poor operation)</p> <ul style="list-style-type: none"> <li>• O/D OFF switch signal malfunction</li> </ul>

### Diagnostic procedure

STEP	INSPECTION	ACTION				
1	<ul style="list-style-type: none"> <li>• Do following symptoms occur concurrently?</li> <li>• Engine flares up or slips during acceleration.</li> <li>• Engine flares up or slips when shifting.</li> </ul>	<table border="0" style="width: 100%;"> <tr> <td style="text-align: center; vertical-align: top; width: 50px;">Yes</td> <td>Go to symptom troubleshooting No.14 "Engine flares up or slips when upshifting or downshifting" or No.15 "Engine flares up or slips when accelerating vehicle".</td> </tr> <tr> <td style="text-align: center; vertical-align: top;">No</td> <td>Repeat basic inspection and repair or replace any defective parts according to inspection result. (See 05-03-6 AUTOMATIC TRANSAXLE BASIC INSPECTION.)</td> </tr> </table>	Yes	Go to symptom troubleshooting No.14 "Engine flares up or slips when upshifting or downshifting" or No.15 "Engine flares up or slips when accelerating vehicle".	No	Repeat basic inspection and repair or replace any defective parts according to inspection result. (See 05-03-6 AUTOMATIC TRANSAXLE BASIC INSPECTION.)
Yes	Go to symptom troubleshooting No.14 "Engine flares up or slips when upshifting or downshifting" or No.15 "Engine flares up or slips when accelerating vehicle".					
No	Repeat basic inspection and repair or replace any defective parts according to inspection result. (See 05-03-6 AUTOMATIC TRANSAXLE BASIC INSPECTION.)					

#### Note

- If malfunction remains, inspect related Service Bulletins and perform repair or diagnosis.
- If vehicle is repaired, troubleshooting is completed.
- If vehicle is not repaired or additional diagnostic information is not available, replace PCM.

# SYMPTOM TROUBLESHOOTING

## NO.23 TRANSAXLE OVERHEATS

A3U050301030W27

<b>23</b>	<b>Transaxle overheats</b>
<b>DESCRIPTION</b>	<ul style="list-style-type: none"> <li>Burnt smell is emitted from transaxle.</li> <li>Smoke is emitted from transaxle.</li> </ul>
<b>POSSIBLE CAUSE</b>	<ul style="list-style-type: none"> <li>The malfunction is restricted to hindrance of coolant at the oil cooler. In addition, overheating of the transaxle may be caused by a malfunction of the TFT sensor.                             <ol style="list-style-type: none"> <li>Burned (TCC)                                     <ul style="list-style-type: none"> <li>Control valve body malfunction</li> <li>Accelerator cable misadjustment</li> </ul> </li> <li>Oil cooler malfunction (Foreign material mixed in with ATF)</li> <li>TFT sensor malfunction</li> <li>Excessive amount of ATF</li> <li>Torque converter malfunction</li> </ol> </li> </ul>

### Diagnostic procedure

STEP	INSPECTION		ACTION
1	<ul style="list-style-type: none"> <li>Inspect for bend, damage, corrosion or kinks of oil cooler pipes.</li> <li>Are oil cooler pipes okay?</li> </ul>	Yes	Go to next step.
		No	Replace any defective parts.
2	<ul style="list-style-type: none"> <li>Remove torque converter.</li> <li>Inspect torque converter. (See ATX Workshop Manual.)</li> <li>Is torque converter okay?</li> </ul>	Yes	Repeat basic inspection and repair or replace any defective parts according to inspection result. (See 05-03-6 AUTOMATIC TRANSAXLE BASIC INSPECTION.)
		No	Replace torque converter.

05-03

#### Note

- If malfunction remains, inspect related Service Bulletins and perform repair or diagnosis.
- If vehicle is repaired, troubleshooting is completed.
- If vehicle is not repaired or additional diagnostic information is not available, replace PCM.

## NO.24 ENGINE STALLS WHEN SHIFTED TO D, 2, 1 RANGES, OR IN R POSITION

A3U050301030W28

<b>24</b>	<b>Engine stalls when shifted to D, 2, 1 ranges, or in R position</b>
<b>DESCRIPTION</b>	<ul style="list-style-type: none"> <li>Engine stalls when shifting from N or P position to D, 2, 1 ranges or R position at idle.</li> </ul>
<b>POSSIBLE CAUSE</b>	<ul style="list-style-type: none"> <li>The malfunction is on the engine control side (i.e. IAC system). Otherwise, the malfunction is in the input/turbine speed sensor (engine sometimes starts) or TCC circuit (engine always stalls).</li> </ul>

### Diagnostic procedure

STEP	INSPECTION		ACTION
1	<ul style="list-style-type: none"> <li>Go to symptom troubleshooting No.4 "Engine stalls". (See 01-03A-7 SYMPTOM DIAGNOSTIC INDEX [ZM].)</li> <li>(See 01-03B-7 SYMPTOM DIAGNOSTIC INDEX [FS].)</li> <li>Is engine control system okay?</li> </ul>	Yes	Repeat basic inspection and repair or replace any defective parts according to inspection result. (See 05-03-6 AUTOMATIC TRANSAXLE BASIC INSPECTION.)
		No	Repair or replace any defective parts according to inspection results.

#### Note

- If malfunction remains, inspect related Service Bulletins and perform repair or diagnosis.
- If vehicle is repaired, troubleshooting is completed.
- If vehicle is not repaired or additional diagnostic information is not available, replace PCM.

## NO.25 ENGINE STALLS WHEN DRIVING AT SLOW SPEED OR STOPPING

A3U050301030W29

<b>25</b>	<b>Engine stalls when driving at slow speed or stopping</b>
<b>DESCRIPTION</b>	<ul style="list-style-type: none"> <li>Engine stalls when brake pedal is depressed while driving at low speed or stopping.</li> </ul>
<b>POSSIBLE CAUSE</b>	<ul style="list-style-type: none"> <li>The malfunction is on the engine control side (e.g. Fuel injection control and IAC system).</li> </ul>

## SYMPTOM TROUBLESHOOTING

### Diagnostic procedure

STEP	INSPECTION	ACTION	
1	<ul style="list-style-type: none"> <li>• Go to symptom troubleshooting No.9 "Low idle/stalls during deceleration". (See 01-03A-7 SYMPTOM DIAGNOSTIC INDEX [ZM].) (See 01-03B-7 SYMPTOM DIAGNOSTIC INDEX [FS].)</li> <li>• Is engine control system okay?</li> </ul>	Yes	Go to next step.
		No	Repair or replace any defective parts according to inspection results.
2	<ul style="list-style-type: none"> <li>• Go to symptom troubleshooting No.4 "Engine Stalls". (See 01-03A-7 SYMPTOM DIAGNOSTIC INDEX [ZM].) (See 01-03B-7 SYMPTOM DIAGNOSTIC INDEX [FS].)</li> <li>• Is engine control system okay?</li> </ul>	Yes	Repeat basic inspection and repair or replace any defective parts according to inspection result. (See 05-03-6 AUTOMATIC TRANSAXLE BASIC INSPECTION.)
		No	Repair or replace any defective parts according to inspection results.

#### Note

- If malfunction remains, inspect related Service Bulletins and perform repair or diagnosis.
- If vehicle is repaired, troubleshooting is completed.
- If vehicle is not repaired or additional diagnostic information is not available, replace PCM.

### NO.26 O/D OFF INDICATOR LIGHT DOES NOT ILLUMINATE WHEN O/D OFF SWITCH IS TURNED TO ON

A3U050301030W30

26	O/D OFF indicator light does not illuminate when O/D OFF switch is turned to ON
<b>DESCRIPTION</b>	<ul style="list-style-type: none"> <li>• O/D OFF indicator light in instrument cluster does not illuminate when O/D OFF switch is turned on and ignition switch at on.</li> </ul>
<b>POSSIBLE CAUSE</b>	<ul style="list-style-type: none"> <li>• O/D OFF switch, O/D OFF indicator light or related wiring harness malfunction</li> </ul>

### NO.27 O/D OFF INDICATOR LIGHT ILLUMINATES WHEN O/D OFF SWITCH IS NOT TURNED TO ON

A3U050301030W31

27	O/D OFF indicator light illuminates when O/D OFF switch is not turned to ON
<b>DESCRIPTION</b>	<ul style="list-style-type: none"> <li>• O/D OFF indicator light in instrument cluster illuminates even though O/D OFF switch is turned off and ignition switch at on.</li> </ul>
<b>POSSIBLE CAUSE</b>	<ul style="list-style-type: none"> <li>• O/D OFF switch or related wiring harness malfunction</li> </ul>

**05-10 CLUTCH**

<b>CLUTCH COMPONENT</b>		
<b>LOCATION INDEX</b> .....	05-10-2	
<b>GENERAL PROCEDURES</b> .....	05-10-3	
Clutch Pipe Removal/Installation Note.	05-10-3	
<b>CLUTCH FLUID INSPECTION</b> .....	05-10-3	
<b>CLUTCH FLUID</b>		
<b>REPLACEMENT/AIR BLEEDING</b> .....	05-10-3	
<b>CLUTCH PEDAL INSPECTION</b> .....	05-10-3	
Clutch Pedal Height Inspection .....	05-10-3	
Clutch Pedal Free Play Inspection....	05-10-4	
<b>CLUTCH PEDAL ADJUSTMENT</b> .....	05-10-4	
Clutch Pedal Height Adjustment .....	05-10-4	
Clutch Pedal Free Play Adjustment ...	05-10-4	
Clutch Pedal Disengagement Stroke..	05-10-4	
<b>CLUTCH PEDAL</b>		
<b>REMOVAL/INSTALLATION</b> .....	05-10-5	
<b>CLUTCH MASTER CYLINDER</b>		
<b>REMOVAL/INSTALLATION</b> .....	05-10-6	
<b>CLUTCH MASTER CYLINDER</b>		
<b>DISASSEMBLY/ASSEMBLY</b> .....	05-10-7	
Snap Ring Disassembly Note .....	05-10-7	
		Snap Ring Assembly Note .....
		05-10-8
		<b>CLUTCH RELEASE CYLINDER</b>
		<b>REMOVAL/INSTALLATION</b> .....
		05-10-8
		<b>CLUTCH RELEASE CYLINDER</b>
		<b>DISASSEMBLY/ASSEMBLY</b> .....
		05-10-10
		<b>CLUTCH UNIT</b>
		<b>REMOVAL/INSTALLATION</b> .....
		05-10-11
		Clutch Cover Removal Note .....
		05-10-12
		Pilot Bearing Removal Note .....
		05-10-12
		Flywheel Removal Note .....
		05-10-12
		Flywheel Installation Note.....
		05-10-12
		Pilot Bearing Installation Note.....
		05-10-13
		Clutch Disc Installation Note.....
		05-10-13
		Clutch Cover Installation Note.....
		05-10-13
		<b>CLUTCH COVER INSPECTION</b> .....
		05-10-13
		<b>CLUTCH DISC INSPECTION</b> .....
		05-10-14
		<b>CLUTCH RELEASE COLLAR</b>
		<b>INSPECTION</b> .....
		05-10-15
		<b>PILOT BEARING INSPECTION</b> .....
		05-10-15
		<b>FLYWHEEL INSPECTION</b> .....
		05-10-15

05-10

# CLUTCH

## CLUTCH COMPONENT LOCATION INDEX

A3U051016003W01

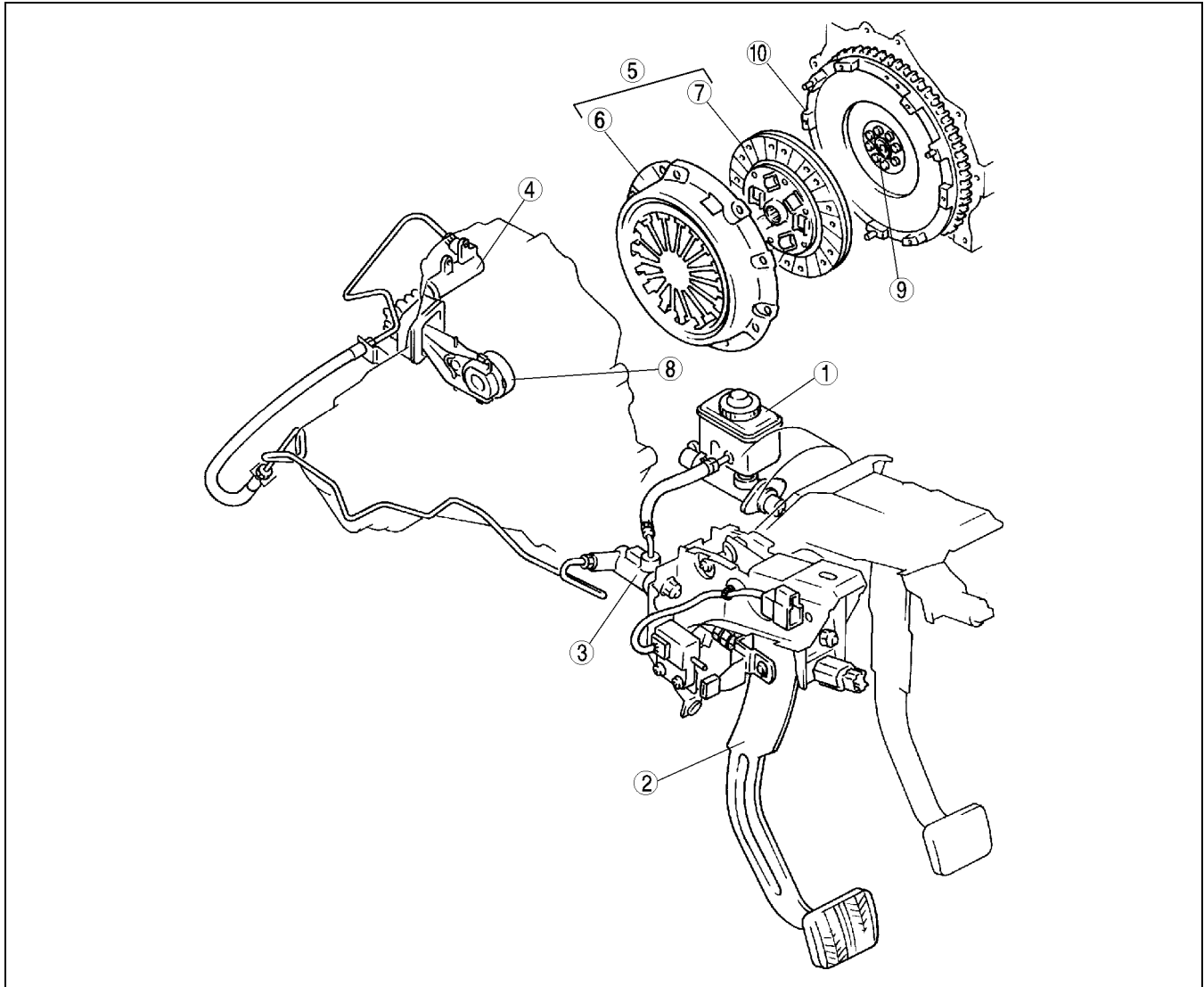

Z3U510W01

1	Clutch fluid (See 05-10-3 CLUTCH FLUID INSPECTION) (See 05-10-3 CLUTCH FLUID REPLACEMENT/ AIR BLEEDING)
2	Clutch pedal (See 05-10-3 CLUTCH PEDAL INSPECTION) (See 05-10-4 CLUTCH PEDAL ADJUSTMENT) (See 05-10-5 CLUTCH PEDAL REMOVAL/ INSTALLATION)
3	Clutch master cylinder (See 05-10-6 CLUTCH MASTER CYLINDER REMOVAL/INSTALLATION) (See 05-10-7 CLUTCH MASTER CYLINDER DISASSEMBLY/ASSEMBLY)
4	Clutch release cylinder (See 05-10-8 CLUTCH RELEASE CYLINDER REMOVAL/INSTALLATION) (See 05-10-10 CLUTCH RELEASE CYLINDER DISASSEMBLY/ASSEMBLY)

5	Clutch unit (See 05-10-11 CLUTCH UNIT REMOVAL/ INSTALLATION)
6	Clutch cover (See 05-10-13 CLUTCH COVER INSPECTION)
7	Clutch disc (See 05-10-14 CLUTCH DISC INSPECTION)
8	Clutch release collar (See 05-10-15 CLUTCH RELEASE COLLAR INSPECTION)
9	Pilot bearing (See 05-10-15 PILOT BEARING INSPECTION)
10	Flywheel (See 05-10-15 FLYWHEEL INSPECTION)

# CLUTCH

## GENERAL PROCEDURES

A3U051016003W02

### Clutch Pipe Removal/Installation Note

- When any clutch pipe has been disconnected anytime during the procedure, add brake fluid, bleed the air, and inspect for leakage after the procedure has been completed.
- When removing the clutch pipe, remove it using the **SST** (49 0259 770B). When installing the clutch pipe, change the clutch pipe tightening torque to allow for use of a torque wrench-**SST** (49 0259 770B) combination, and then tighten the clutch pipe using the **SST** (49 0259 770B). (See 00-00-15 Torque Formulas.)

## CLUTCH FLUID INSPECTION

A3U051016010W01

### Note

- A common reservoir is used for the clutch and brake system fluid.
- The fluid in the reservoir must be maintained between the MIN/MAX level during replacement.

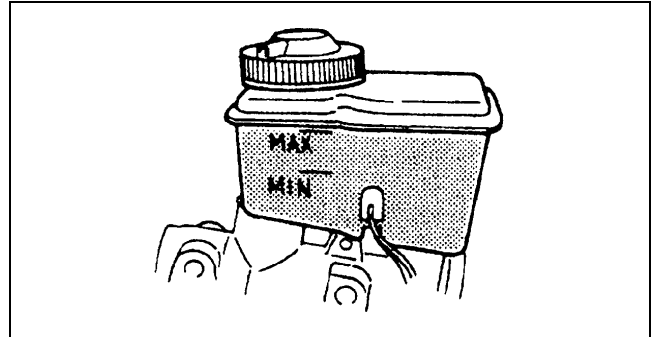

U3U51001

05-10

## CLUTCH FLUID REPLACEMENT/AIR BLEEDING

A3U051016010W02

1. Remove the splash shield.

### Caution

- **Clutch fluid will damage painted surfaces. Be sure to use a container or rags to collect it. If fluid does get on a painted surface, wipe it off immediately with a rag.**

### Note

- Do not mix different brands of fluid.
- Do not reuse the clutch fluid that was drained.

2. Draw the fluid from the reservoir with a suction pump.
3. Remove the bleeder cap from the clutch release cylinder and attach a vinyl hose to the bleeder plug.
4. Place the other end of the vinyl hose in a clear container.
5. Slowly pump the clutch pedal several times.
6. With the clutch pedal depressed, loosen the bleeder screw using the **SST** to let the fluid escape. Close the bleeder screw using the **SST**.
7. Repeat Steps 5 and 6 until only clean fluid is seen.
8. Tighten the bleeder screw.

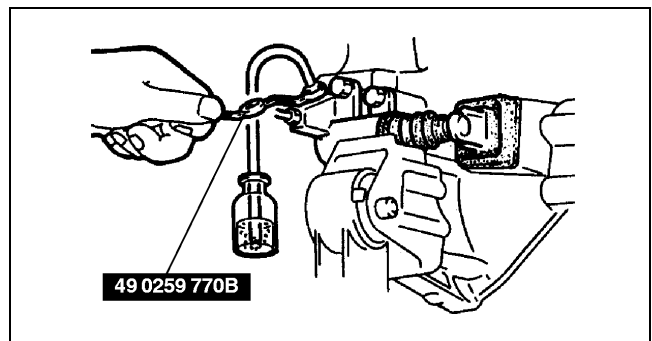

U5U51002

### Tightening torque

5.9—8.8 N·m {60—90 kgf·cm, 53—78 in·lbf}

9. Add fluid to the MAX mark.
10. Install the splash shield.
11. Verify the correct clutch operation.

## CLUTCH PEDAL INSPECTION

A3U051041030W01

### Clutch Pedal Height Inspection

1. Measure the distance from the upper surface of the pedal pad to the set plate.
  - If not as specified, adjust the clutch pedal height.

### Pedal height

210—215 mm {8.27—8.46 in} [from set plate]



# CLUTCH

## Clutch Pedal Free Play Inspection

1. Depress the clutch pedal by hand until clutch resistance is felt, and measure the pedal free play.
  - If not as specified, adjust the clutch pedal free play.

### Free play

0.7—3.5 mm {0.03—0.13 in}

### Total free play

5.6—15.0 mm {0.23—0.59 in}

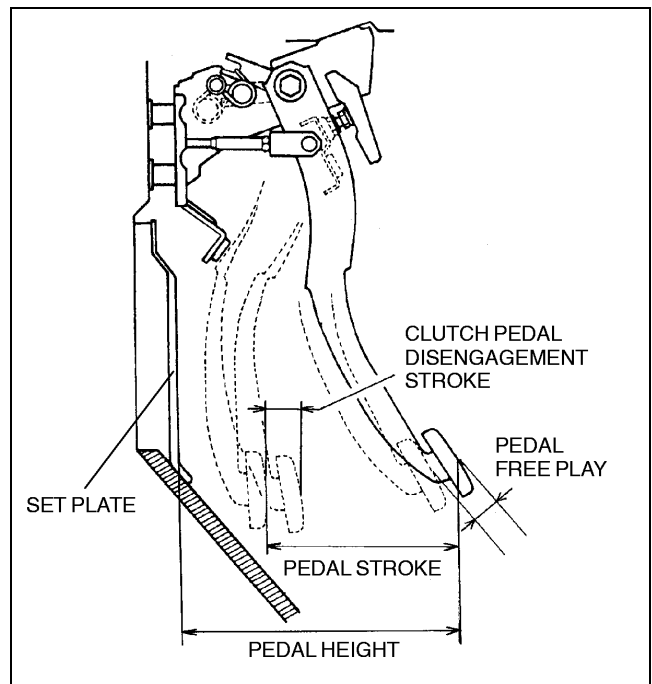

X3U510WA0

## CLUTCH PEDAL ADJUSTMENT

### Clutch Pedal Height Adjustment

1. Adjust the pedal height by turning locknut A and adjustment bolt B.

### Pedal height

210—215 mm {8.27—8.46 in} [from set plate]

### Clutch Pedal Free Play Adjustment

1. Adjust the pedal free play by turning locknut C and adjusting push rod D.

### Pedal free play

0.7—3.5 mm {0.03—0.13 in}

### Clutch Pedal Disengagement Stroke

1. Measure the clutch pedal disengagement stroke.
  - If the clutch pedal disengagement stroke is not within the specification, adjust the pedal height and pedal free play, and verify the pedal stroke.

### Clutch pedal disengagement stroke

45—55 mm {1.8—2.1 in} (reference value)

### Pedal stroke

130—140 mm {5.12—5.51 in} (reference value)

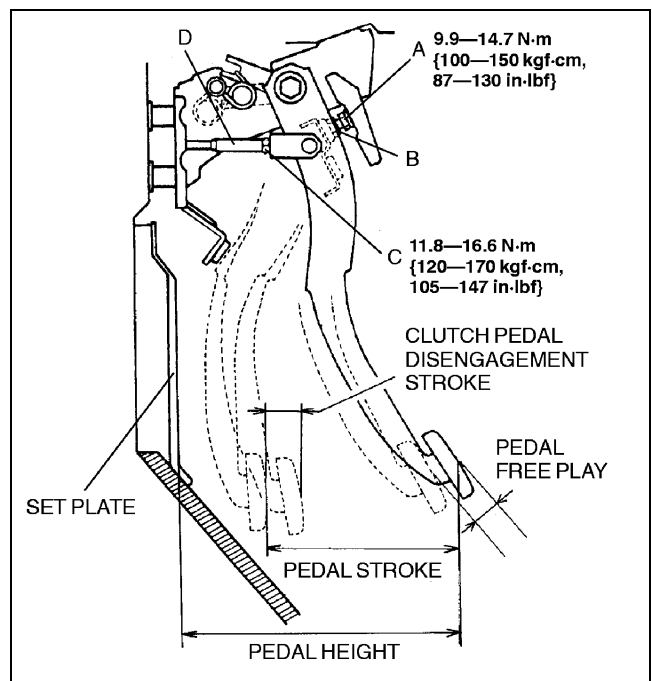

Y3U510WA0

# CLUTCH

## CLUTCH PEDAL REMOVAL/INSTALLATION

A3U051041030W03

1. Disconnect the negative battery cable.
2. Remove in the order indicated in the table.
3. Install in the reverse order of removal.
4. After installation, adjust the clutch pedal. (See 05-10-4 CLUTCH PEDAL ADJUSTMENT.)

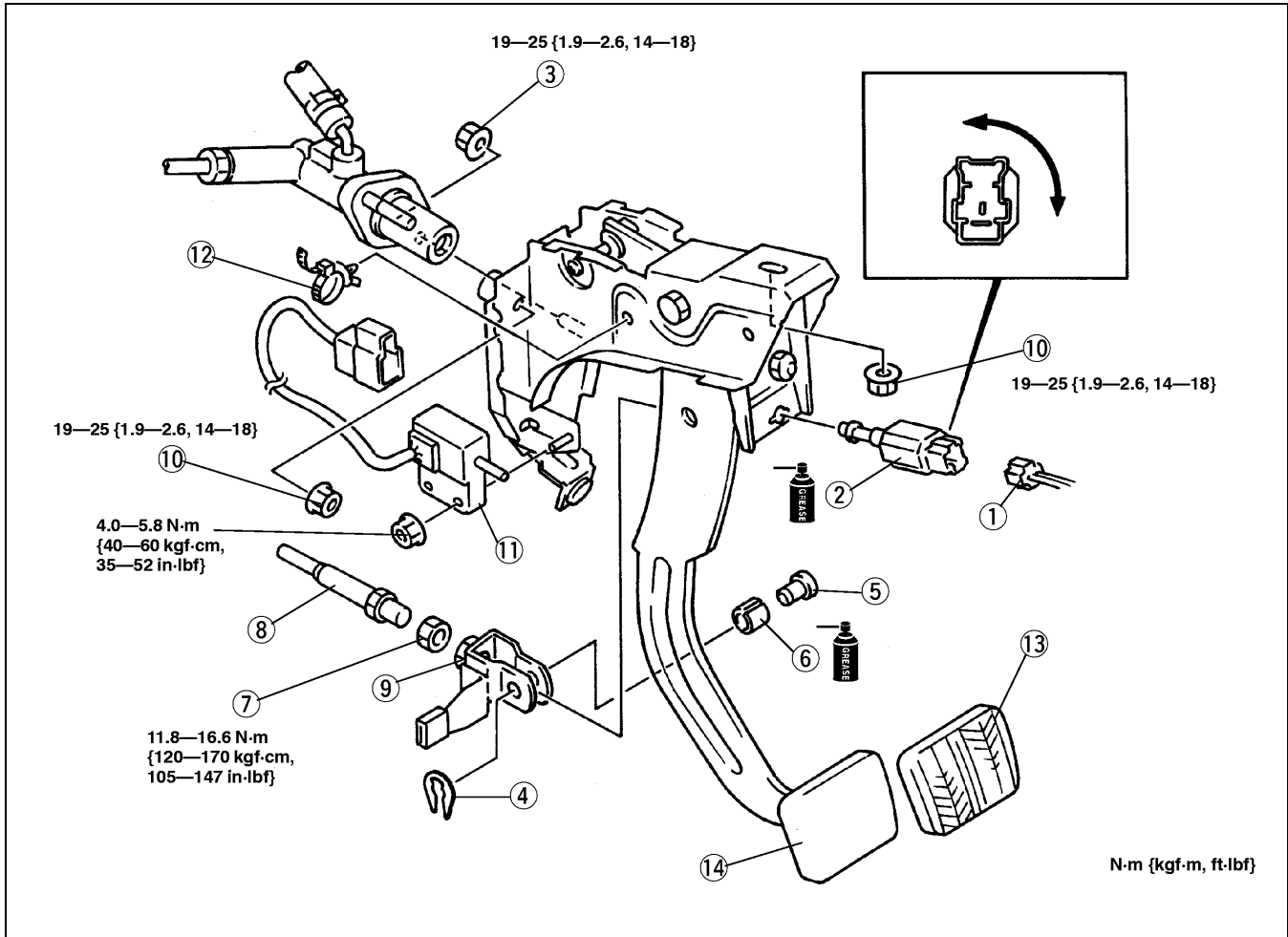

05-10

X3U510WA2

1	Clutch switch connector
2	Clutch switch
3	Nut
4	Clip
5	Pin
6	Bushing
7	Locknut

8	Push rod
9	Fork end
10	Nut
11	Clutch cut switch
12	Band
13	Pedal pad
14	Clutch pedal

# CLUTCH

## CLUTCH MASTER CYLINDER REMOVAL/INSTALLATION

A3U051041990W01

1. Remove the battery and battery cover.

### Caution

- Clutch fluid will damage painted surfaces. Be sure to use a container or rags to collect it. If fluid does get on a painted surface, wipe it off immediately with a rag.

2. Remove in the order indicated in the table.
3. Install in the reverse order of removal.

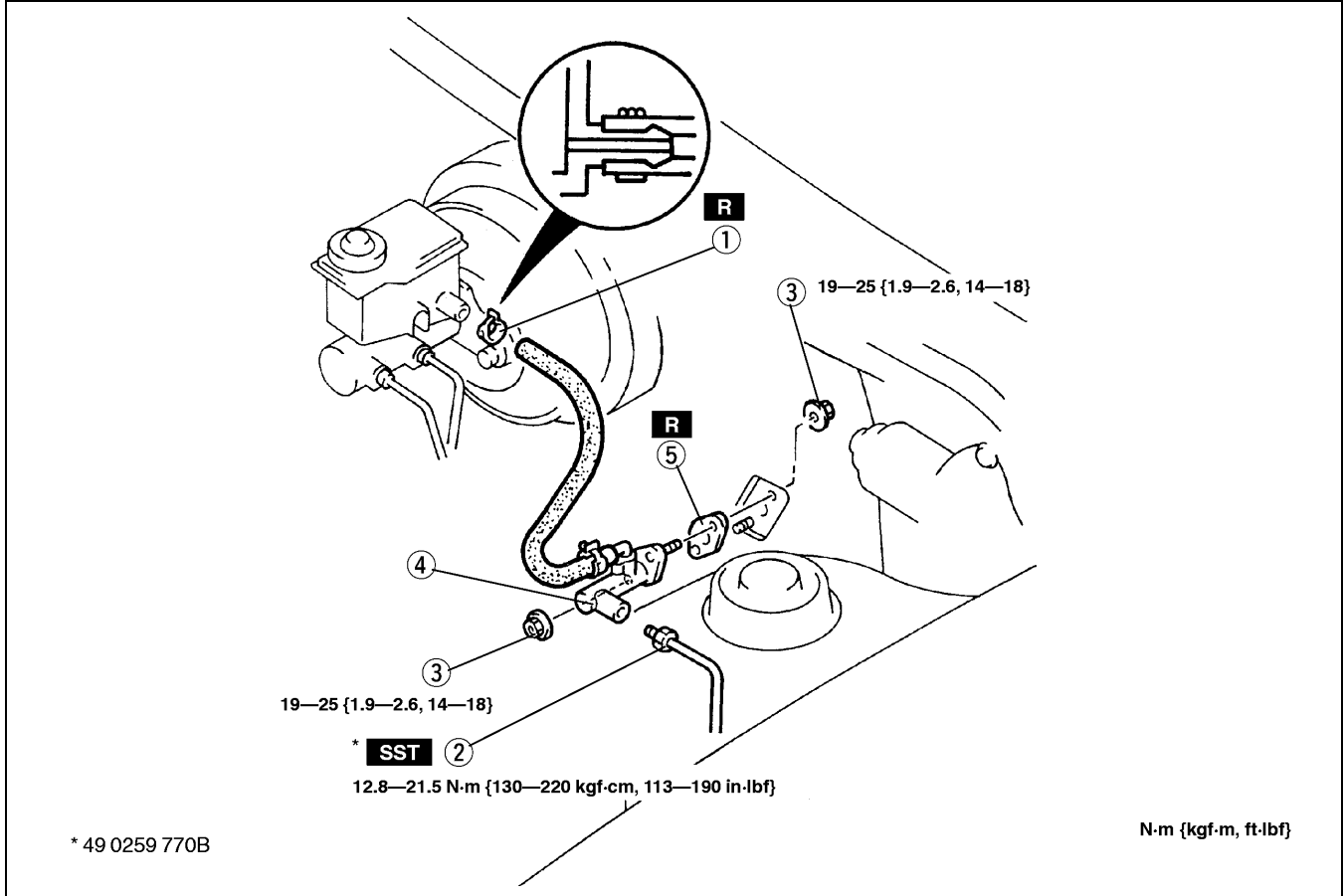

X3U510WA3

1	Clip
2	Clutch pipe
3	Nut

4	Clutch master cylinder
5	Gasket

# CLUTCH

## CLUTCH MASTER CYLINDER DISASSEMBLY/ASSEMBLY

A3U051041990W02

1. Disassemble in the order indicated in the table.

### Warning

- Using compressed air can cause dirt and other particles to fly out, causing injury to the eyes. Wear protective eye wear whenever using compressed air.

2. Assemble in the reverse order of disassembly.

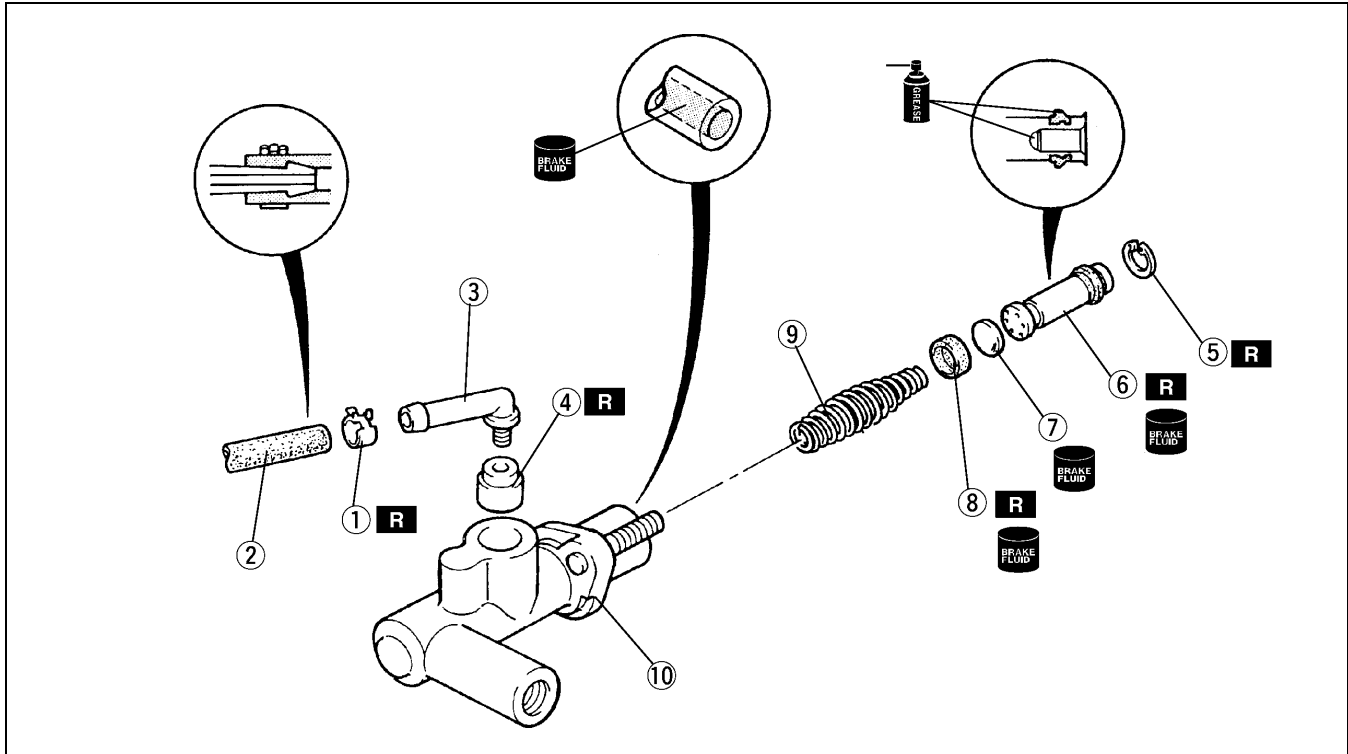

X3U510WA4

1	Clip
2	Hose
3	Joint
4	Bushing
5	Snap ring (See 05-10-7 Snap Ring Disassembly Note.) (See 05-10-8 Snap Ring Assembly Note.)

6	Piston and secondary cup component
7	Spacer
8	Primary cup
9	Return spring
10	Clutch master cylinder body

### Snap Ring Disassembly Note

1. Hold the piston down with a cloth-wrapped pin punch.

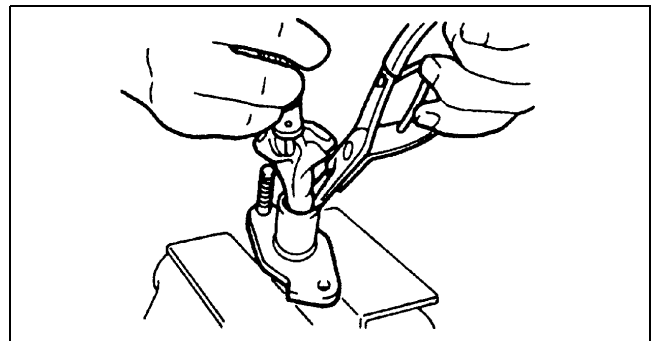

U3U51007

# CLUTCH

## Snap Ring Assembly Note

1. Hold the piston down using a cloth-wrapped pin punch.

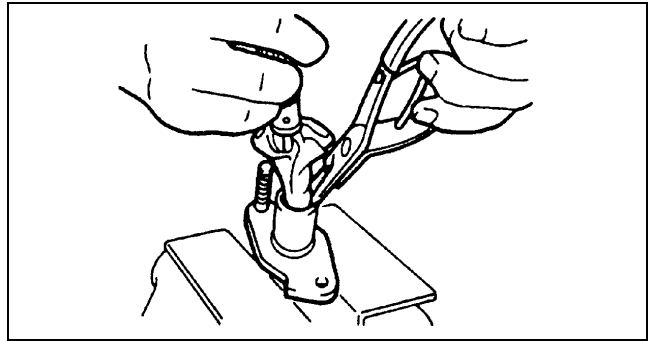

U3U51007

## CLUTCH RELEASE CYLINDER REMOVAL/INSTALLATION

A3U051041920W01

### Caution

- Clutch fluid will damage painted surfaces. If clutch fluid does get on a painted surface, wipe it off immediately.

1. Remove in the order indicated in the table.
2. Plug the clutch pipe after removing it to avoid leakage.
3. Install in the reverse order of removal.

### FS engine

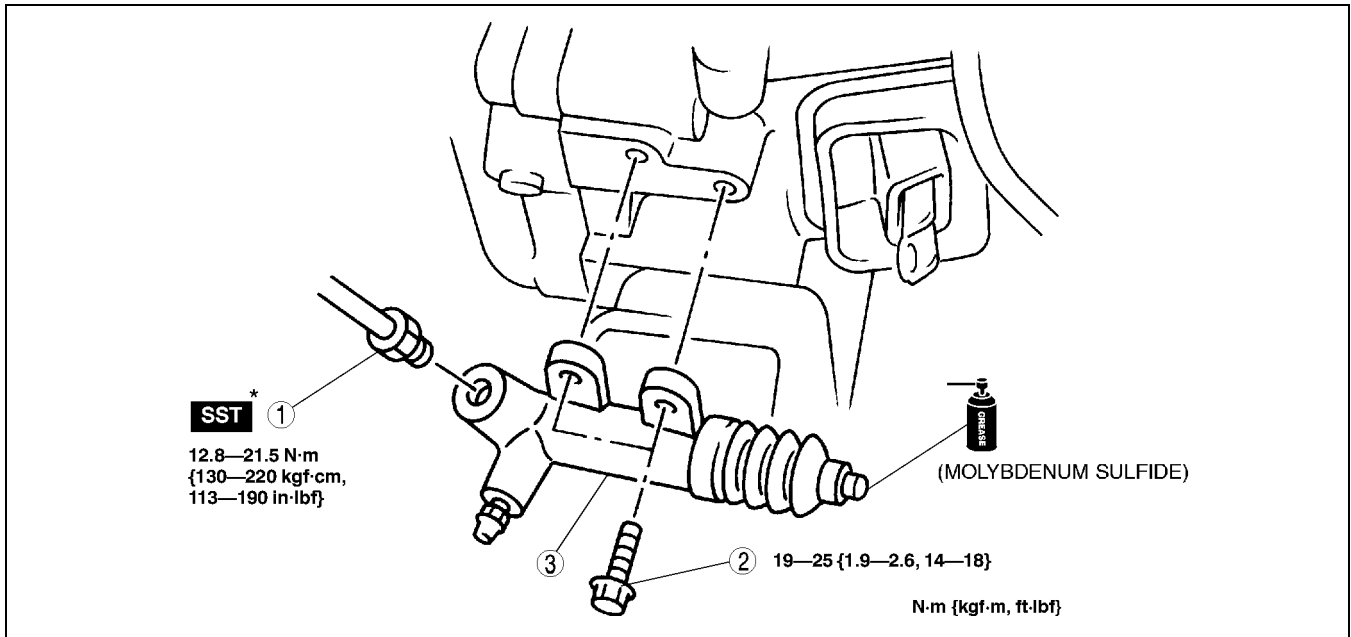

Z3U510W02

# CLUTCH

## ZM engine

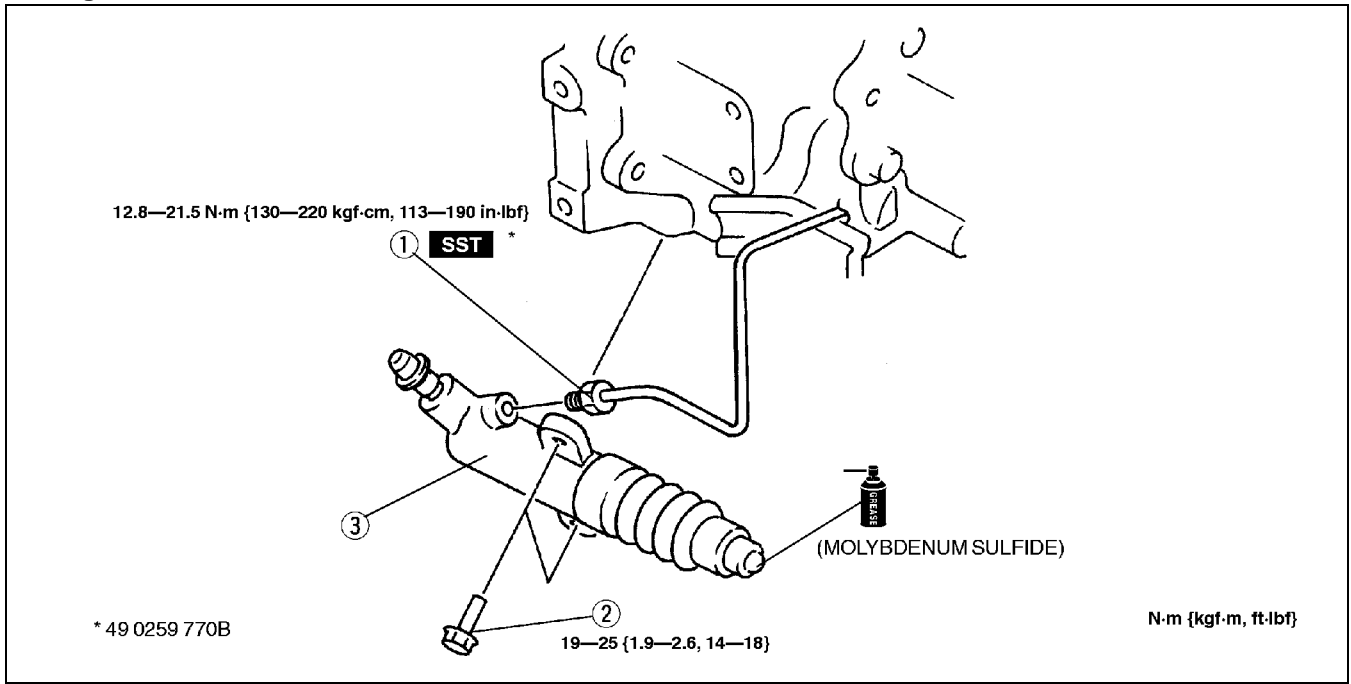

05-10

1	Clutch pipe
2	Bolt

3	Clutch release cylinder
---	-------------------------

# CLUTCH

## CLUTCH RELEASE CYLINDER DISASSEMBLY/ASSEMBLY

A3U051041920W02

1. Disassemble in the order indicated in the table.

### Warning

- Using compressed air can cause dirt and other particles to fly out, causing injury to the eyes. Wear protective eye wear whenever using compressed air.

2. Wipe all parts, and use compressed air to clean all ports, passages, and inner parts.  
3. Assemble in the reverse order of disassembly.

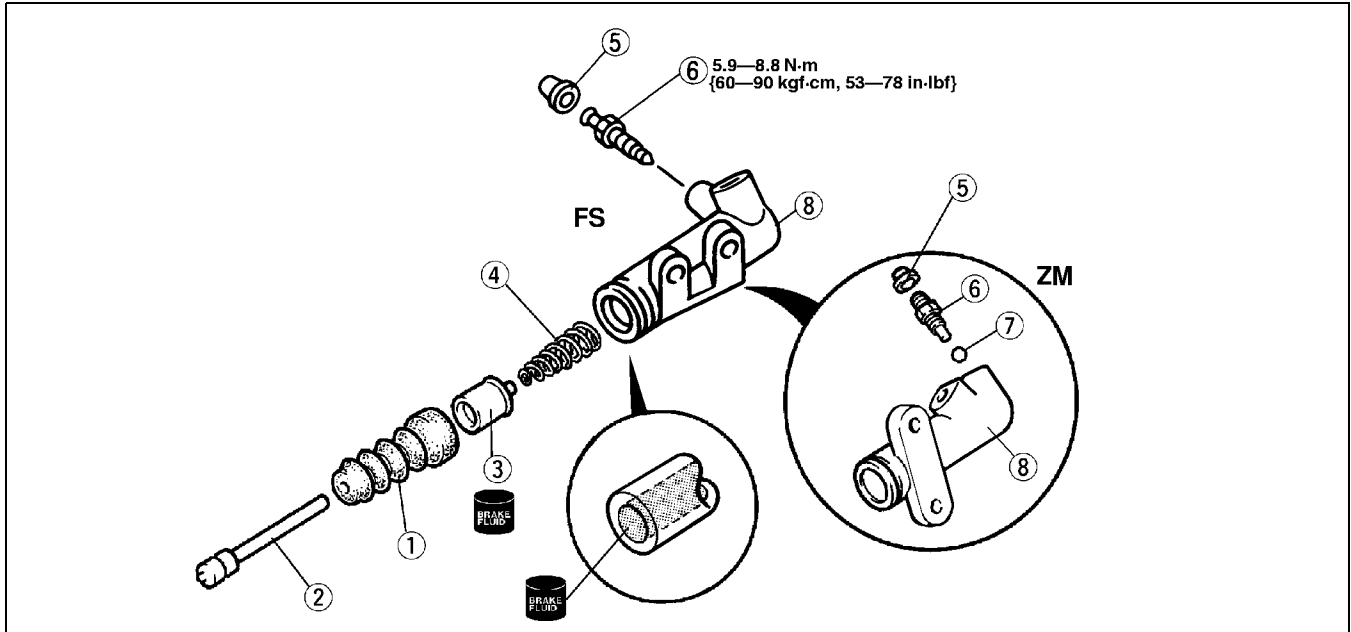

Z3U510W03

1	Boot
2	Push rod
3	Piston and cup component
4	Return spring

5	Bleeder cap
6	Bleeder screw
7	Steel ball
8	Clutch release cylinder body

# CLUTCH

## CLUTCH UNIT REMOVAL/INSTALLATION

A3U051016000W01

1. Disconnect the negative battery cable.
2. Remove in the order indicated in the table.
3. Install in the reverse order of removal.

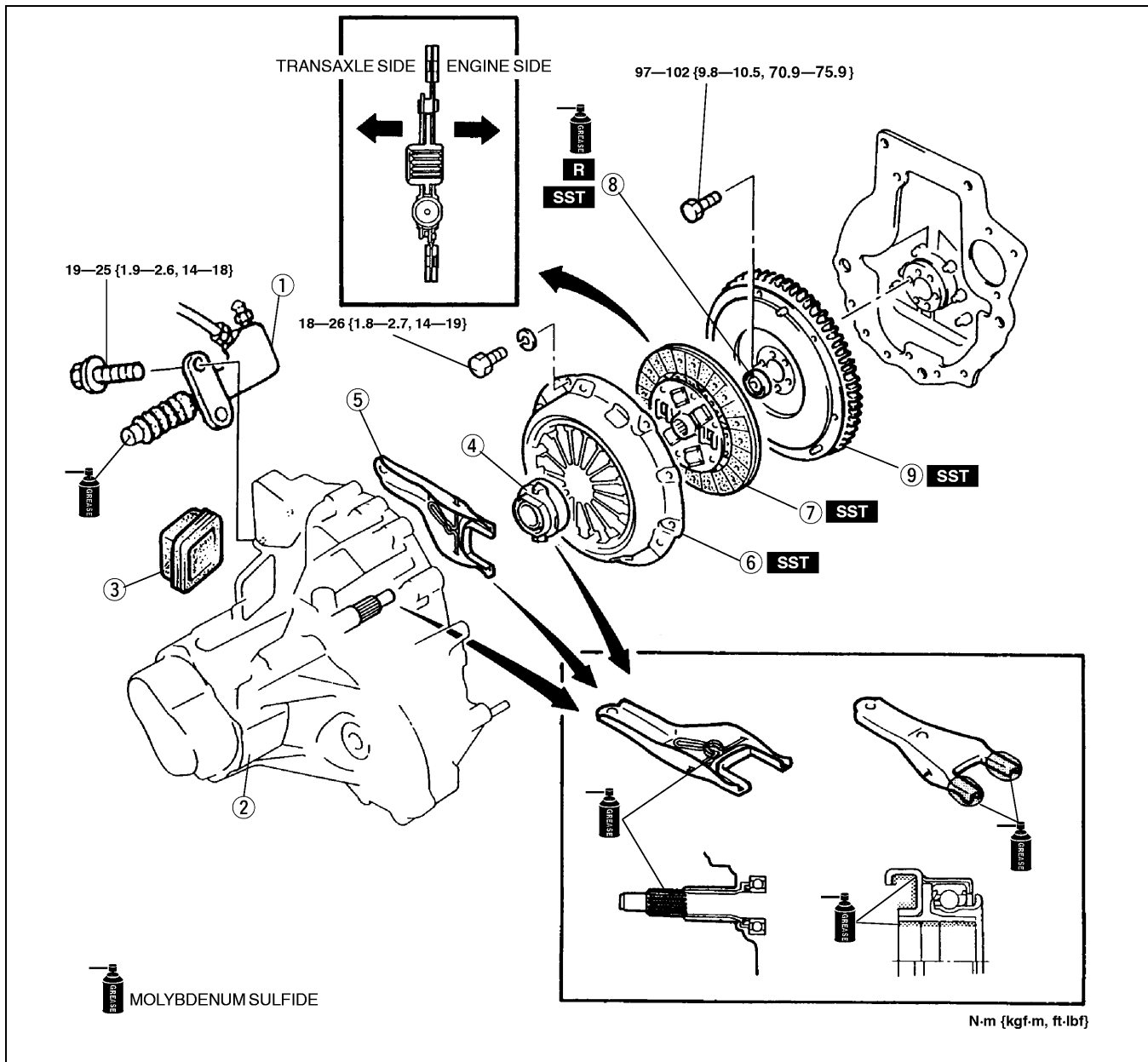

05-10

Y3U510WA1

1	Clutch release cylinder
2	Transaxle (See 05-15A-4 MANUAL TRANSAXLE (MTX) REMOVAL/INSTALLATION [F25M-R].) (See 05-15B-4 MANUAL TRANSAXLE (MTX) REMOVAL/INSTALLATION [G15M-R].)
3	Boot
4	Clutch release collar
5	Clutch release fork

6	Clutch cover (See 05-10-12 Clutch Cover Removal Note.) (See 05-10-13 Clutch Cover Installation Note.)
7	Clutch disc (See 05-10-13 Clutch Disc Installation Note.)
8	Pilot bearing (See 05-10-12 Pilot Bearing Removal Note.) (See 05-10-13 Pilot Bearing Installation Note.)
9	Flywheel (See 05-10-12 Flywheel Removal Note.) (See 05-10-12 Flywheel Installation Note.)



# CLUTCH

## Clutch Cover Removal Note

1. Install the **SSTs**.
2. Loosen each bolt one turn at a time in a crisscross pattern until the spring tension is released.
3. Remove the clutch cover and disc.

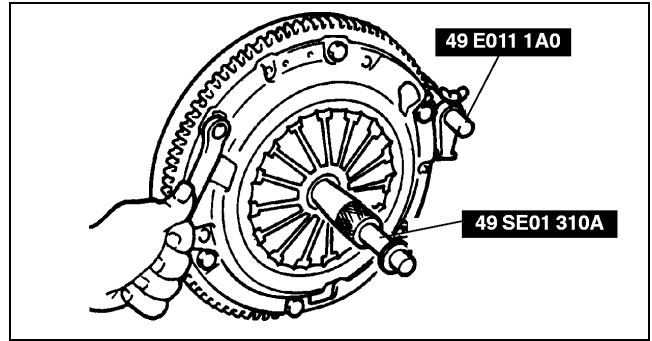

X3U510WA8

## Pilot Bearing Removal Note

### Note

- The pilot bearing does not need to be removed unless you are replacing it.

1. Use the **SSTs** to remove the pilot bearing.

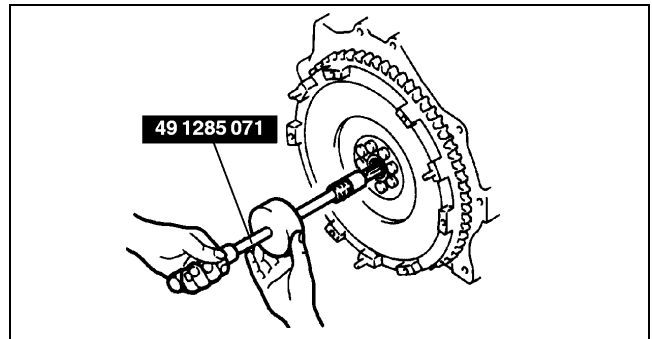

X3U510WA9

## Flywheel Removal Note

1. Hold the flywheel using the **SST**.
2. Remove the bolts evenly and gradually in the pattern shown.
3. Remove the flywheel.
4. Inspect for oil leakage from the crankshaft rear oil seal.
  - If there is any such leakage or if the oil seal is damaged, replace the crankshaft rear oil seal.

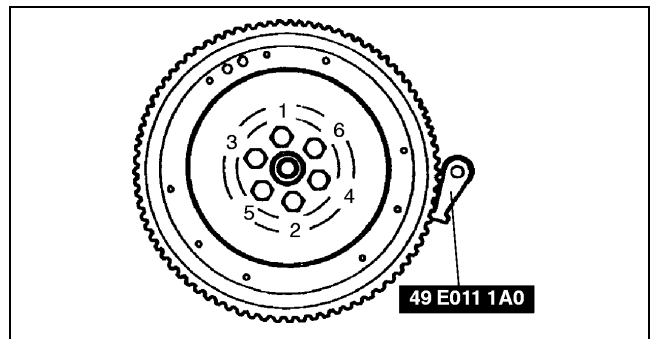

U3U51013

## Flywheel Installation Note

1. Install the flywheel to the crankshaft.
2. Hand-tighten the flywheel installation bolts.
3. Install the **SST** to the flywheel.
4. Tighten the flywheel installation bolts in the pattern shown.

### Tightening torque

97—102 N·m {9.8—10.5 kgf·m, 70.9—75.9 ft·lbf}

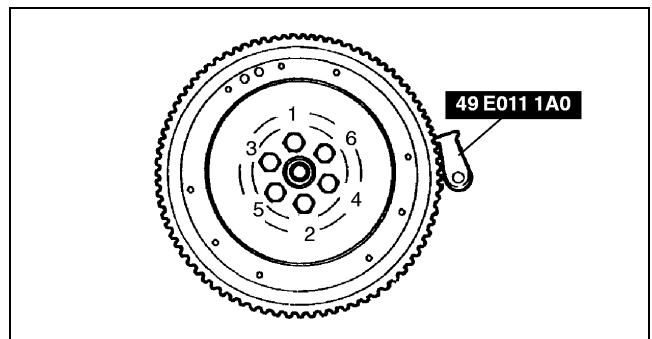

U3U51014

# CLUTCH

## Pilot Bearing Installation Note

1. Install a new pilot bearing using the **SST**.

**Bearing installation depth**  
0—0.4 mm {0—0.01 in}

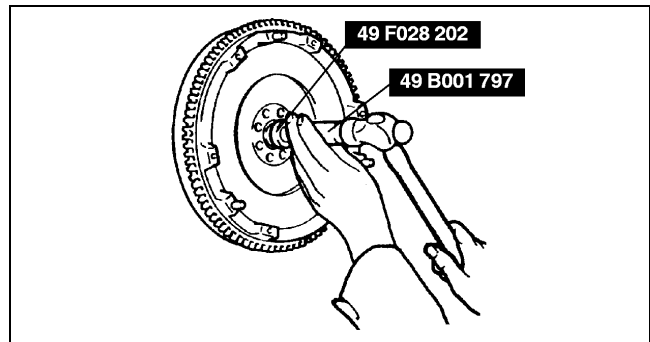

X3U510WB0

## Clutch Disc Installation Note

1. Hold the clutch disc in position using the **SSTs**.

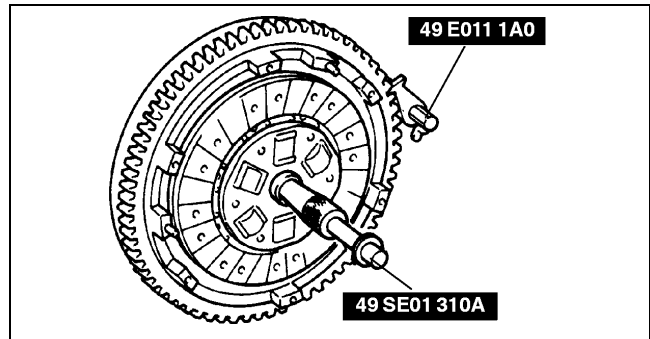

U3U51016

05-10

## Clutch Cover Installation Note

1. Install the **SSTs**.
2. Tighten the bolts evenly and gradually in the pattern shown.

**Tightening torque**  
18—26 N·m {1.8—2.7 kgf·m, 14—19 ft·lbf}

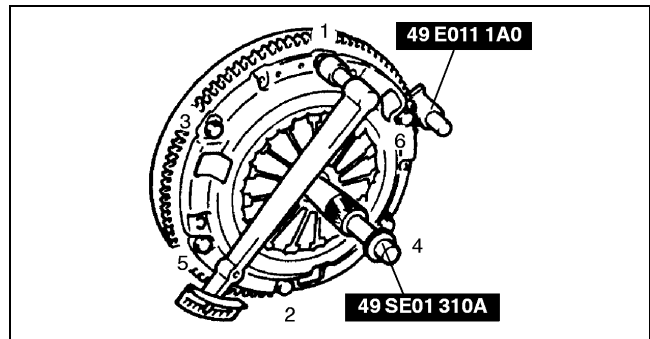

U3U51017

## CLUTCH COVER INSPECTION

1. Measure the wear of the diaphragm spring fingers.

**Depth**  
0.5 mm {0.020 in} max.

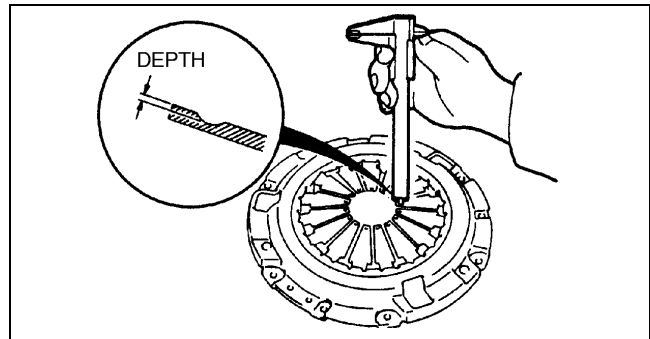

U3U51018

A3U051016410W01

# CLUTCH

2. Measure the flatness of the pressure plate surface using a straightedge and a feeler gauge as shown in the figure.

**Maximum clearance**  
**0.5 mm {0.020 in}**

**Note**

- When inspecting the diaphragm spring fingers, mount a dial indicator on the cylinder block.

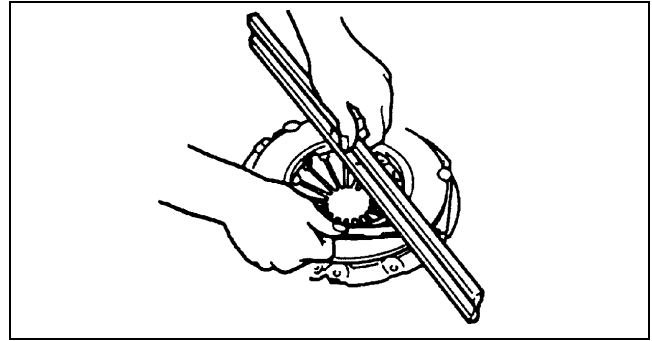

U3U51019

3. Rotate the flywheel and inspect for misaligned diaphragm spring fingers.
  - If the misalignment exceeds the maximum, replace the clutch cover.

**Misalignment**  
**0.6 mm {0.024 in} max.**

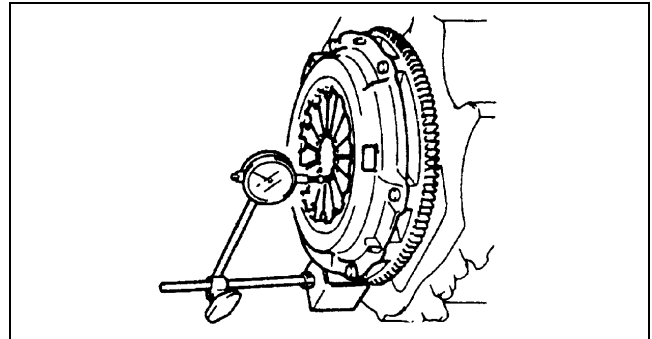

U3U51020

## CLUTCH DISC INSPECTION

1. Inspect the contact surface of the clutch disc for scoring, cracks, burning, and oil contamination.
2. Remove minor scoring or burning using emery paper.
  - Repair if scoring or burning is major.
  - Replace if cracked or contaminated with oil.
3. Inspect for loose facing rivets and dampers.
  - If the clutch disc is loose, replace the clutch disc.

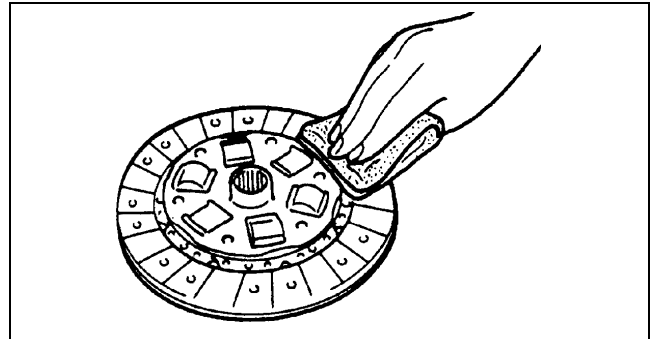

U3U51021

4. Using vernier calipers, measure the thickness of the lining at a rivet head on both sides.
  - If the thickness of the lining at any rivet head is less than the minimum, replace the clutch disc.

**Thickness**  
**0.3 mm {0.012 in} min.**

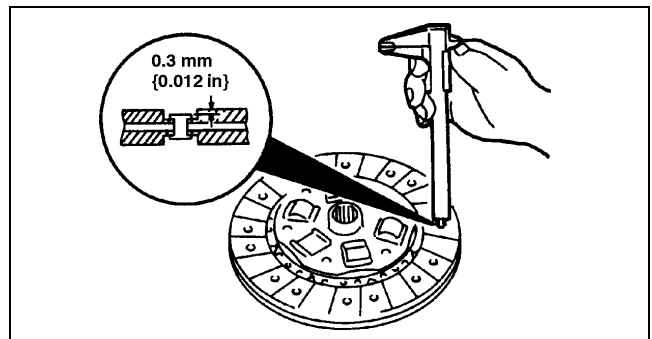

W3U510WC1

# CLUTCH

5. Measure the clutch disc runout using a dial indicator.
  - If the runout exceeds the maximum, replace the clutch disc.

## Runout

**0.7 mm {0.028 in} max.**

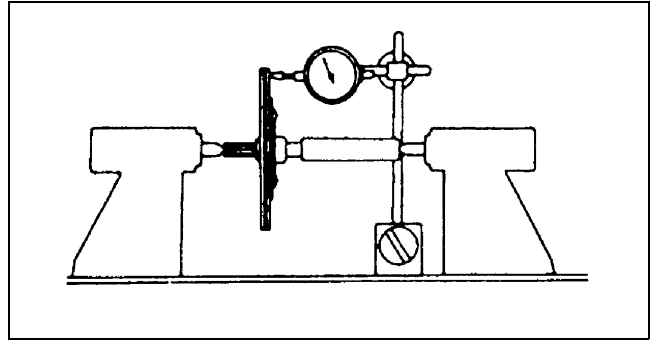

U3U51023

## CLUTCH RELEASE COLLAR INSPECTION

A3U051016510W01

### Caution

- **Cleaning the clutch release collar with cleaning fluids or a steam cleaner can wash the grease out of the sealed bearing.**

1. Turn the collar while applying force in the axial direction.
  - If the collar sticks or has excessive resistance, replace it.

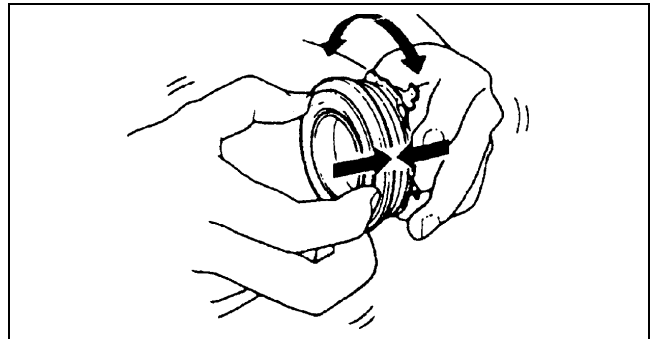

U3U51024

## PILOT BEARING INSPECTION

A3U051011501W01

1. Without removing the pilot bearing from the flywheel, turn the bearing while applying force in the axial direction.
  - If the bearing sticks or has excessive resistance, replace it.

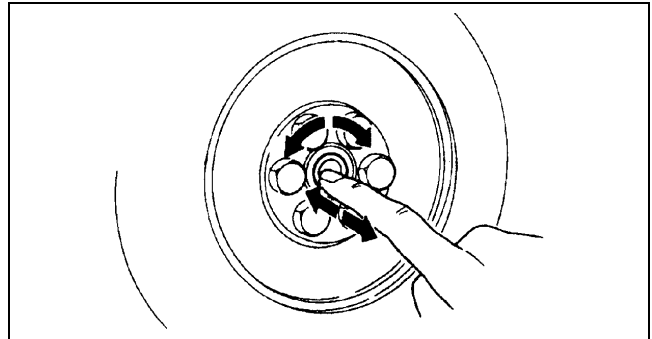

U3U51025

## FLYWHEEL INSPECTION

A3U051011500W01

1. Inspect the contact surface for scoring, cracks, and burning.
2. Remove minor scoring or burning using emery paper.
  - Repair if scoring or burning is major.
  - Replace if cracked.
3. Inspect the ring gear teeth for wear and damage.
  - If worn or damaged, replace the flywheel.

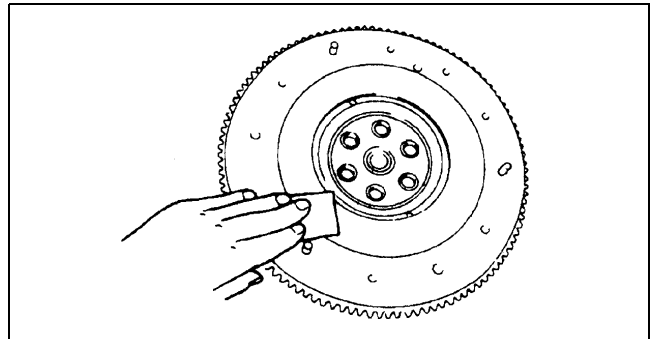

U3U51026

## CLUTCH

4. Install a dial indicator on the cylinder block.
5. Measure the flywheel runout using a dial indicator.
  - If the runout exceeds the maximum, replace the flywheel.

### Runout

**0.2 mm {0.008 in} max.**

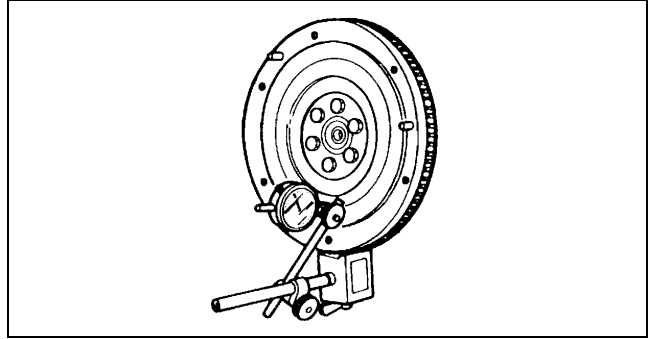

X3U510WB1

# 05-15A MANUAL TRANSAXLE [F25M-R]

MANUAL TRANSAXLE [F25M-R]  
 LOCATION INDEX ..... 05-15A-1  
 TRANSAXLE OIL  
 INSPECTION [F25M-R]..... 05-15A-2  
 TRANSAXLE OIL  
 REPLACEMENT [F25M-R] ..... 05-15A-2  
 OIL SEAL (DIFFERENTIAL) REPLACEMENT  
 [F25M-R] ..... 05-15A-2  
 MANUAL TRANSAXLE (MTX)  
 REMOVAL/INSTALLATION [F25M-R]. 05-15A-4

Lower Arm Ball Joint Removal Note . . . 05-15A-5  
 No.4 Engine Mount Bracket  
 Removal Note ..... 05-15A-5  
 Manual Transaxle (MTX)  
 Removal Note ..... 05-15A-5  
 Manual Transaxle (MTX)  
 Installation Note ..... 05-15A-6  
 Engine Mount Member  
 Installation Note ..... 05-15A-6

## MANUAL TRANSAXLE [F25M-R] LOCATION INDEX

A3U051501025W01

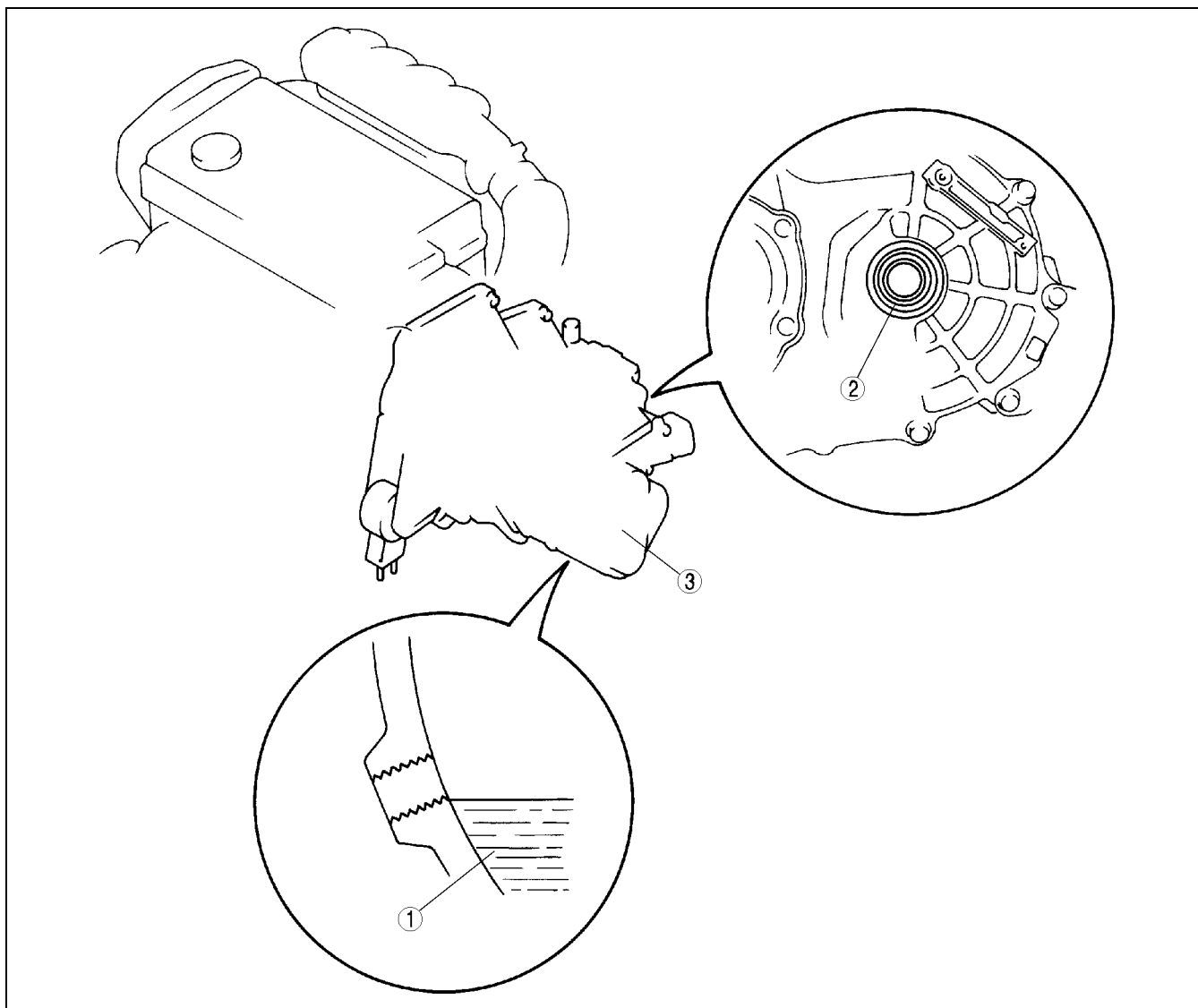

05-15A

1	Transaxle oil (See 05-15A-2 TRANSAXLE OIL INSPECTION [F25M-R]) (See 05-15A-2 TRANSAXLE OIL REPLACEMENT [F25M-R])
---	--

2	Oil seal (differential) (See 05-15A-2 OIL SEAL (DIFFERENTIAL) REPLACEMENT [F25M-R])
3	Manual transaxle (See 05-15A-4 MANUAL TRANSAXLE (MTX) REMOVAL/INSTALLATION [F25M-R])

Z3U515W01

# MANUAL TRANSAXLE [F25M-R]

## TRANSAXLE OIL INSPECTION [F25M-R]

A3U051527001W01

### Note

- Park the vehicle on level ground.

1. Remove the oil level plug and the washer.
2. Verify that the oil is near the bottom of the plug port within the range shown in the figure.
  - If the oil level is low, add the specified type of oil to the bottom of the plug port through the oil level plug hole.

### Specified oil

**Grade:** API service GL-4 or GL-5

**Viscosity:** SAE 75W—90 (All season) or SAE

**80W—90 (Above 10 °C {50 °F})**

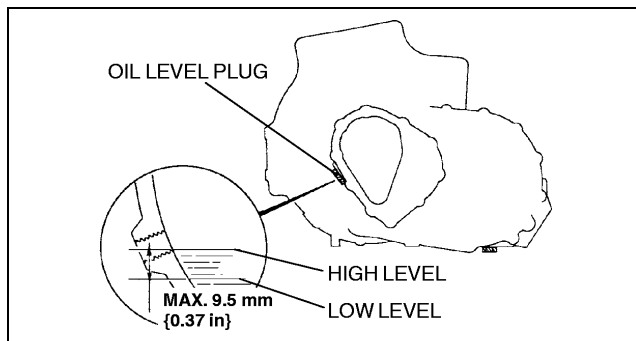

X3U515WA0

3. Install a new washer and the oil level plug.

### Tightening torque

**40—58 N·m {4.0—6.0 kgf·m, 29—43 ft·lbf}**

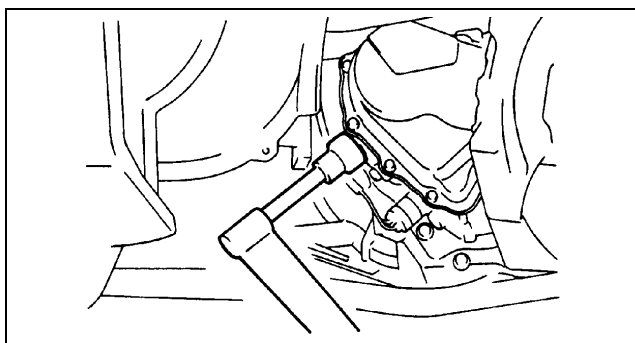

U3U51502

## TRANSAXLE OIL REPLACEMENT [F25M-R]

A3U051527001W02

1. Remove the drain plug and the washer.
2. Drain the oil into a container.
3. Install a new washer and the drain plug.

### Tightening torque

**40—58 N·m {4.0—6.0 kgf·m, 29—43 ft·lbf}**

4. Remove the oil level plug and the washer. Add the specified amount and type of oil through the oil level plug hole until the level reaches the bottom of the oil level plug hole.

### Specified oil

**Grade:** API service GL-4 or GL-5

**Viscosity:** SAE 75W—90 (All season) or SAE

**80W—90 (Above 10 °C {50 °F})**

**Capacity (approximate quantity)**

**2.68 L {2.83 US qt, 2.36 Imp qt}**

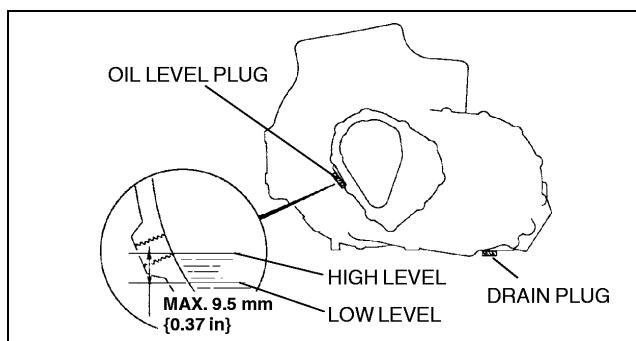

X3U515WA1

5. Install a new washer and the oil level plug.

### Tightening torque

**40—58 N·m {4.0—6.0 kgf·m, 29—43 ft·lbf}**

## OIL SEAL (DIFFERENTIAL) REPLACEMENT [F25M-R]

A3U051527165W01

1. Drain the transaxle oil into a container.
2. Separate the drive shaft and joint shaft from the transaxle. (See 03—13—3 JOINT SHAFT REMOVAL/INSTALLATION.) (See 03—13—9 DRIVE SHAFT REMOVAL/INSTALLATION.)
3. Remove the oil seal using a screwdriver and seal remover.

## MANUAL TRANSAXLE [F25M-R]

4. Using the **SST** and a hammer, tap the new oil seal in evenly until the **SST** contacts the transaxle case.
5. Coat the oil seal lip with transaxle oil.
6. Insert the drive shaft and joint shaft to the transaxle. (See 03-13-3 JOINT SHAFT REMOVAL/INSTALLATION.) (See 03-13-9 DRIVE SHAFT REMOVAL/INSTALLATION.)
7. Add the specified amount and type of transaxle oil. (See 05-15A-2 TRANSAXLE OIL REPLACEMENT [F25M-R].)

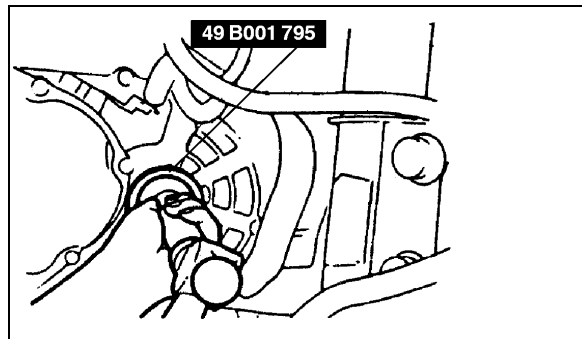

U3U51503

05-15A



# MANUAL TRANSAXLE [F25M-R]

A3U051501029W01

## MANUAL TRANSAXLE (MTX) REMOVAL/INSTALLATION [F25M-R]

1. Remove the battery, battery cover, and battery tray.
2. Remove the fresh-air duct and air cleaner component.
3. Remove the wheels and tires and splash shields.
4. Remove the EGR pipe, front pipe and TWC. (See 01-15-1 EXHAUST SYSTEM REMOVAL/INSTALLATION.)
5. Drain the transaxle oil into a container.
6. Remove the starter. (See 01-19-1 STARTER REMOVAL/INSTALLATION.)
7. Remove in the order indicated in the table.
8. Install in the reverse order of removal.
9. Add the specified amount of the specified transaxle oil. (See 05-15A-2 TRANSAXLE OIL REPLACEMENT [F25M-R].)
10. Warm up the engine and transaxle, inspect for oil leakage, and inspect the transaxle operation.

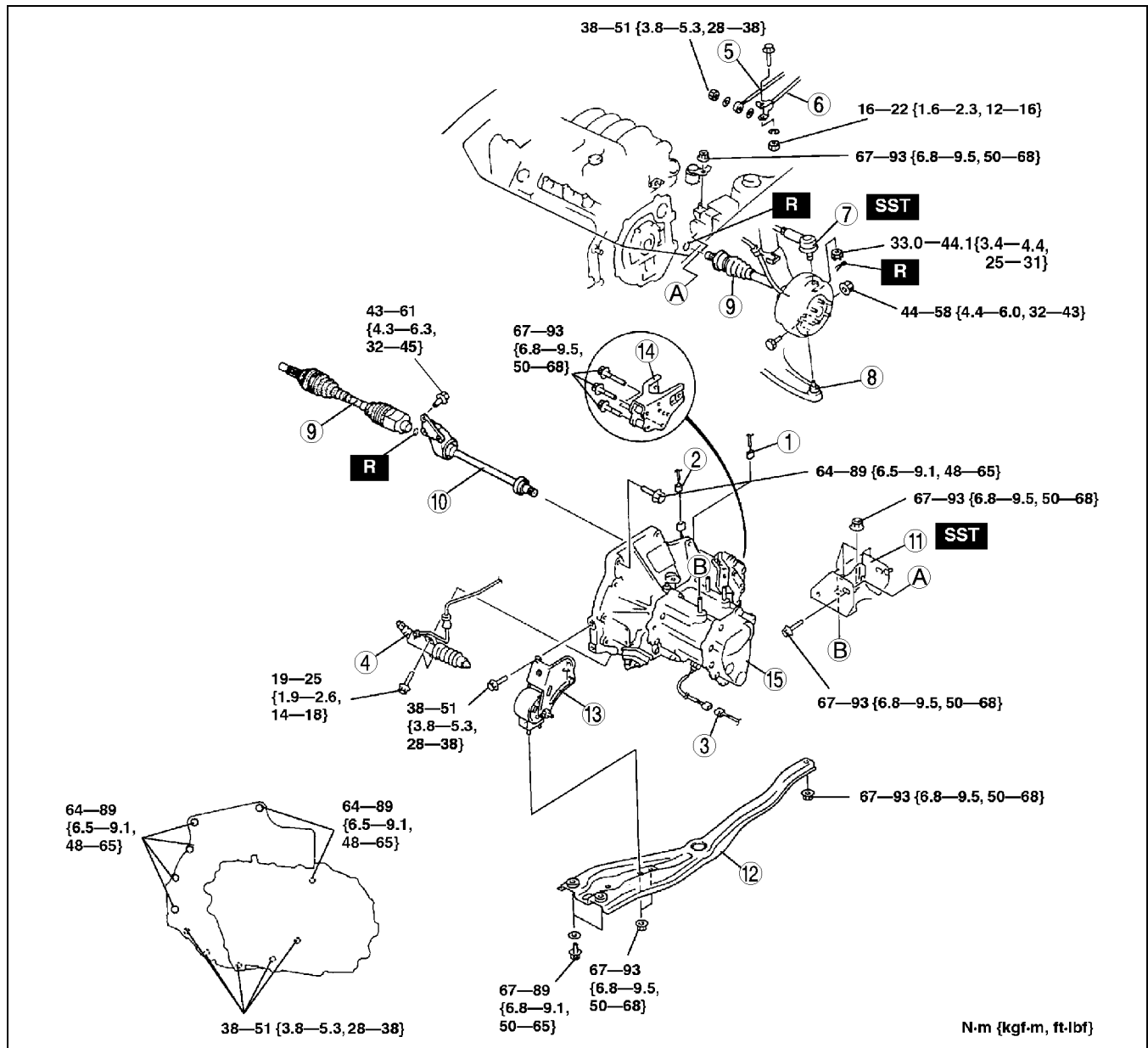

A3U0515W005

1	Speedometer sensor connector
2	Neutral switch connector
3	Back-up light switch connector
4	Clutch release cylinder
5	Extension bar
6	Change control rod

7	Tie-rod end ball joint (See 06-12-9 STEERING GEAR AND LINKAGE REMOVAL/INSTALLATION.)
8	Lower arm ball joint (See 05-15A-5 Lower Arm Ball Joint Removal Note.)

## MANUAL TRANSAXLE [F25M-R]

9	Drive shaft (See 03-13-9 DRIVE SHAFT REMOVAL/ INSTALLATION.)
10	Joint shaft (See 03-13-3 JOINT SHAFT REMOVAL/ INSTALLATION.)
11	No.4 engine mount bracket (See 05-15A-5 No.4 Engine Mount Bracket Removal Note.)
12	Engine mount member (See 05-15A-6 Engine Mount Member Installation Note.)

13	No.2 engine mount
14	No.1 engine mount bracket
15	MTX (See 05-15A-5 Manual Transaxle (MTX) Removal Note.) (See 05-15A-6 Manual Transaxle (MTX) Installation Note.)

### Lower Arm Ball Joint Removal Note

#### Caution

- Wrap a rag around the ball joint dust seal to protect it from getting damages.

1. Pry the lower arm out of the knuckle.

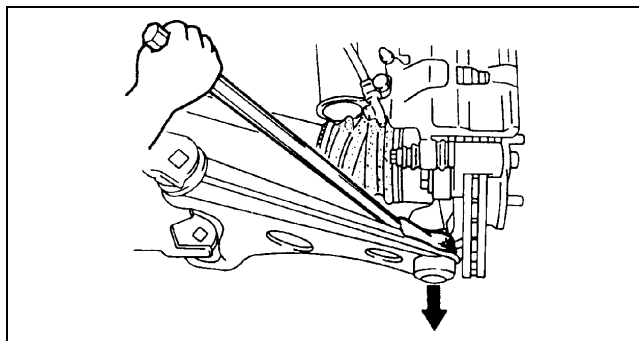

X3U515WA4

05-15A

### No.4 Engine Mount Bracket Removal Note

1. Support the engine using the **SST** before removing the No.4 engine mount bracket.
2. Remove the No.4 engine mount bracket.

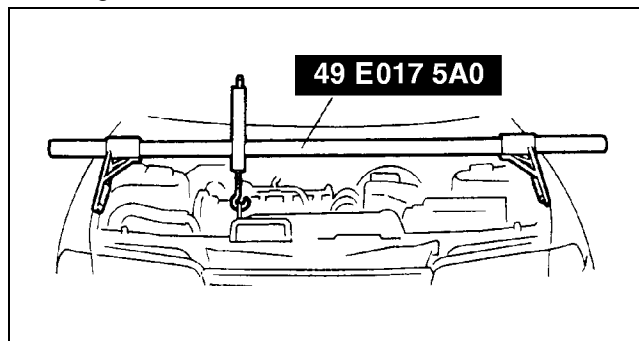

Z3U110WFK

### Manual Transaxle (MTX) Removal Note

1. Loosen the **SST** (49 E017 5A0) and lean the engine toward the transaxle.
2. Support the transaxle on a jack.
3. Remove the transaxle mounting bolts.
4. Remove the transaxle.

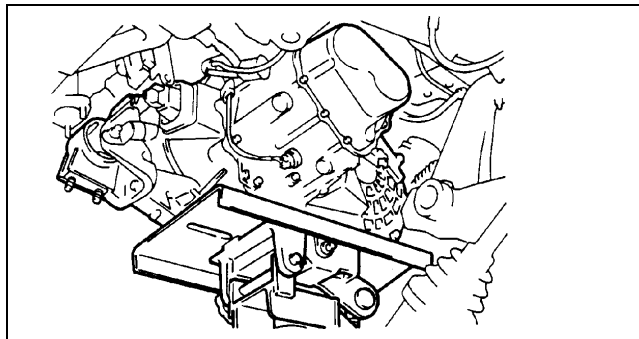

X3U515WA6

# MANUAL TRANSAXLE [F25M-R]

## Manual Transaxle (MTX) Installation Note

1. Set the transaxle on a jack and lift into place.
2. Install the transaxle mounting bolts.

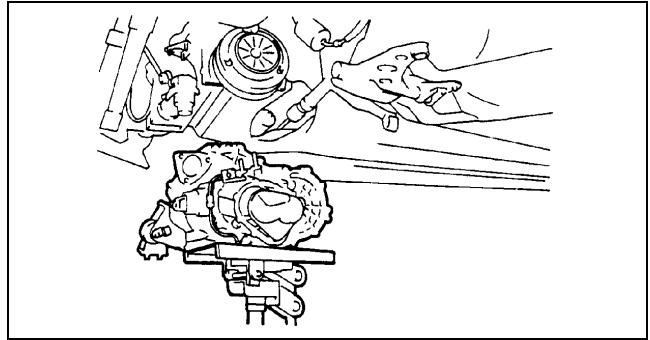

X3U515WA7

## Engine Mount Member Installation Note

1. Verify that the engine mount rubbers are installed as shown.

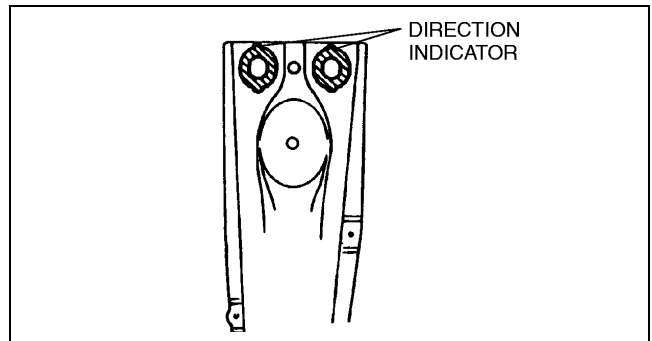

X3U515WA8

2. Put the No.2 engine mount stud bolts in the installation holes when installing the engine mount member.
3. Tighten bolt A and nut B.

### Tightening torque

**Bolt A:** 67—89 N·m {6.8—9.1 kgf·m, 50—65 ft·lbf}

**Nut B:** 67—93 N·m {6.8—9.5 kgf·m, 50—68 ft·lbf}

4. Tighten nuts C.

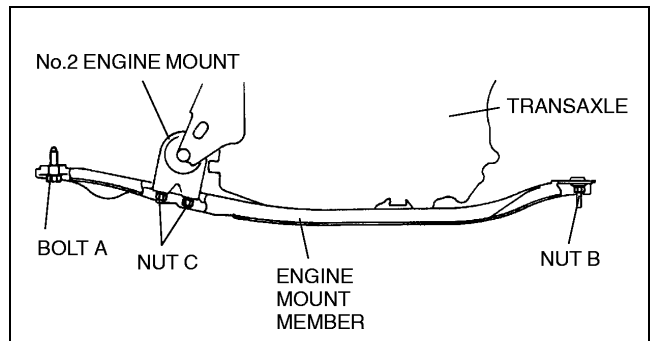

X3U515WA9

### Tightening torque

**Nut C:** 67—93 N·m {6.8—9.5 kgf·m, 50—68 ft·lbf}

5. By aligning the holes with the stud bolts, install the No.4 engine mount bracket to the transaxle.
6. Align the hole of the No.4 engine mount bracket with the No.4 engine mount rubber on vehicle, and temporarily tighten bolt D.
7. Tighten nuts E, then bolt D.

### Tightening torque

**Bolt D and nut E:** 67—93 N·m {6.8—9.5 kgf·m, 50—68 ft·lbf}

8. Remove the SST (49 E017 5A0).

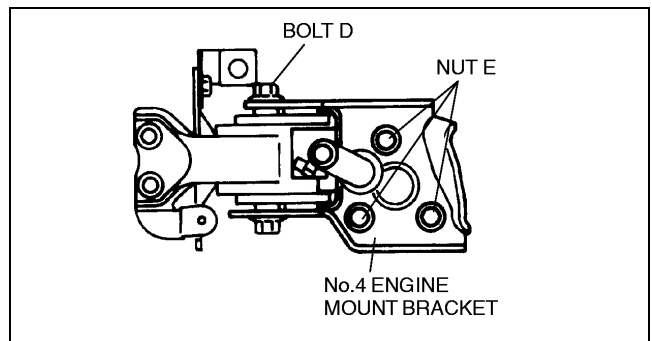

X3U515WB0

# 05-15B MANUAL TRANSAXLE [G15M-R]

MANUAL TRANSAXLE [G15M-R]  
 LOCATION INDEX ..... 05-15B-1  
 TRANSAXLE OIL  
 INSPECTION [G15M-R] ..... 05-15B-2  
 TRANSAXLE OIL  
 REPLACEMENT [G15M-R]. ..... 05-15B-2  
 OIL SEAL (DIFFERENTIAL) REPLACEMENT  
 [G15M-R] ..... 05-15B-2  
 MANUAL TRANSAXLE (MTX)  
 REMOVAL/INSTALLATION [G15M-R]. 05-15B-4

Lower Arm Ball Joint Removal Note . . . 05-15B-5  
 No.4 Engine Mount Bracket  
 Removal Note ..... 05-15B-5  
 Manual Transaxle (MTX)  
 Removal Note ..... 05-15B-5  
 Manual Transaxle (MTX)  
 Installation Note ..... 05-15B-6  
 Engine Mount Member  
 Installation Note ..... 05-15B-6

## MANUAL TRANSAXLE [G15M-R] LOCATION INDEX

A3U051501025W02

05-15B

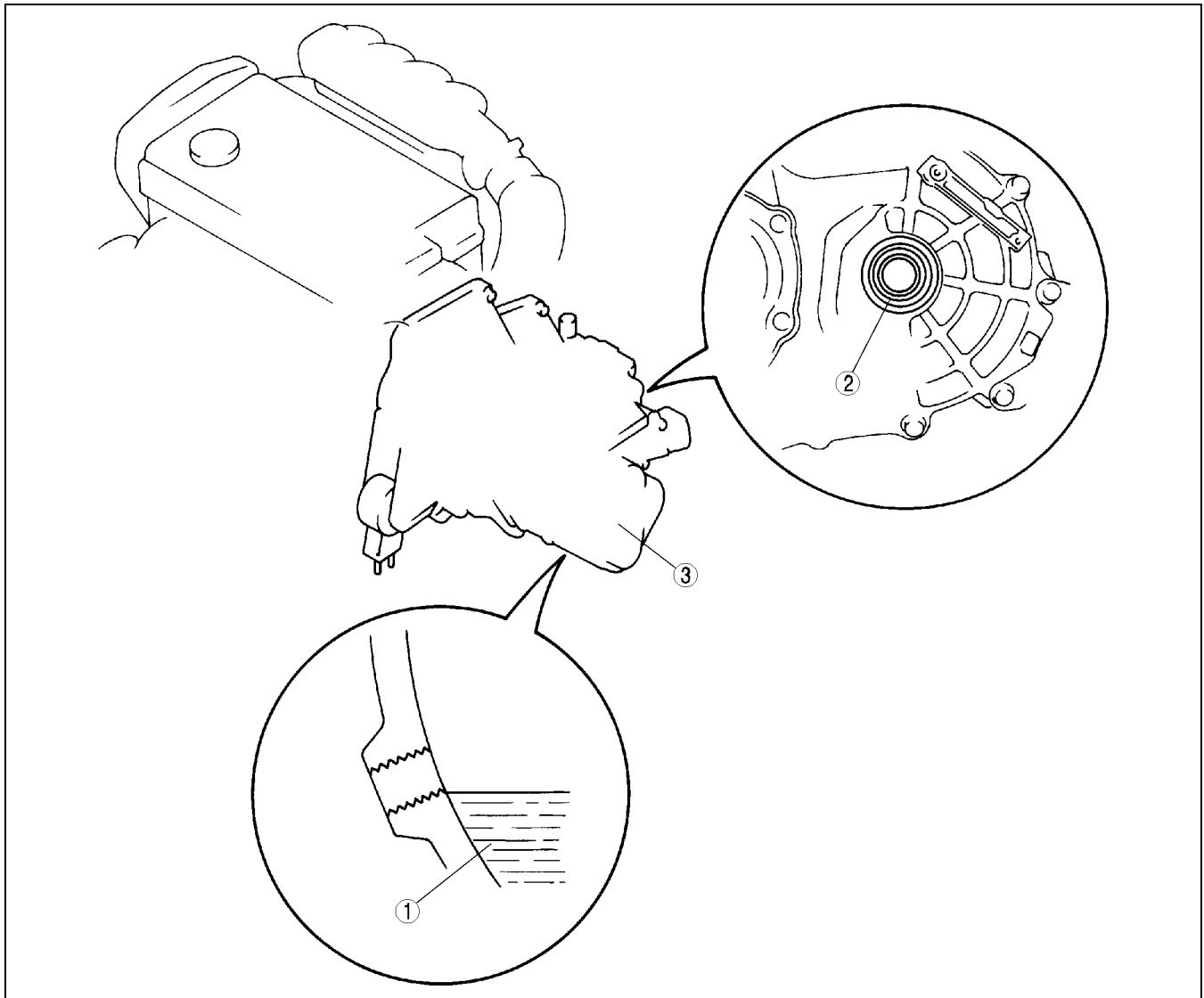

Z3U515W01

1	Transaxle oil (See 05-15B-2 TRANSAXLE OIL INSPECTION [G15M-R]) (See 05-15B-2 TRANSAXLE OIL REPLACEMENT [G15M-R].)
---	---

2	Oil seal (differential) (See 05-15B-2 OIL SEAL (DIFFERENTIAL) REPLACEMENT [G15M-R].)
3	Manual transaxle (See 05-15B-4 MANUAL TRANSAXLE (MTX) REMOVAL/INSTALLATION [G15M-R].)

# MANUAL TRANSAXLE [G15M-R]

## TRANSAXLE OIL INSPECTION [G15M-R]

A3U051527001W03

### Note

- Park the vehicle on level ground.

1. Remove the oil level plug and the washer.
2. Verify that the oil is near the bottom of the plug port within the range shown in the figure.
  - If the oil level is low, add the specified type of oil to the bottom of the plug port through the oil level plug hole.

### Specified oil

**Grade:** API service GL-4 or GL-5

**Viscosity:** SAE 75W—90 (All season) or SAE 80W—90 (Above 10 °C {50 °F})

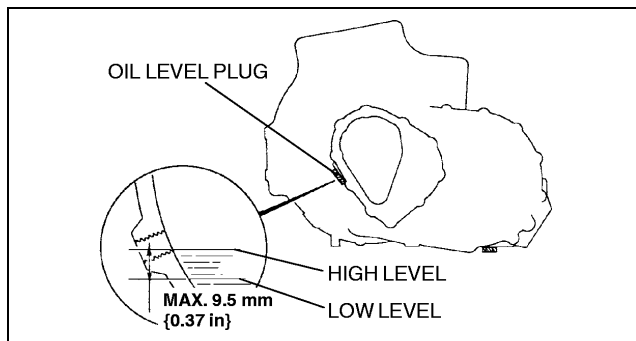

X3U515WA0

3. Install a new washer and the oil level plug.

### Tightening torque

40—58 N·m {4.0—6.0 kgf·m, 29—43 ft·lbf}

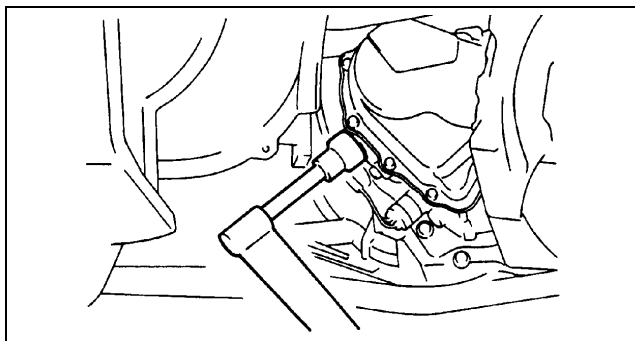

U3U51502

## TRANSAXLE OIL REPLACEMENT [G15M-R]

A3U051527001W04

1. Remove the drain plug and the washer.
2. Drain the oil into a container.
3. Install a new washer and the drain plug.

### Tightening torque

40—58 N·m {4.0—6.0 kgf·m, 29—43 ft·lbf}

4. Remove the oil level plug and the washer. Add the specified amount and type of oil through the oil level plug hole until the level reaches the bottom of the oil level plug hole.

### Specified oil

**Grade:** API service GL-4 or GL-5

**Viscosity:** SAE 75W—90 (All season) or SAE 80W—90 (Above 10 °C {50 °F})

**Capacity (approximate quantity)**

2.68 L {2.83 US qt, 2.36 Imp qt}

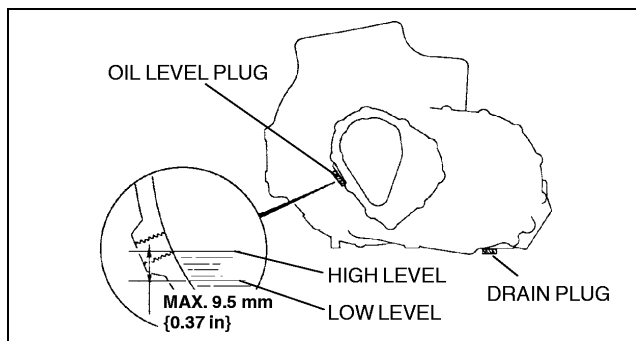

X3U515WA1

5. Install a new washer and the oil level plug.

### Tightening torque

40—58 N·m {4.0—6.0 kgf·m, 29—43 ft·lbf}

## OIL SEAL (DIFFERENTIAL) REPLACEMENT [G15M-R]

A3U051527165W02

1. Drain the transaxle oil into a container.
2. Separate the drive shaft and joint shaft from the transaxle. (See 03-13-3 JOINT SHAFT REMOVAL/INSTALLATION.) (See 03-13-9 DRIVE SHAFT REMOVAL/INSTALLATION.)
3. Remove the oil seal using a screwdriver and seal remover.

## MANUAL TRANSAXLE [G15M-R]

4. Using the **SST** and a hammer, tap the new oil seal in evenly until the **SST** contacts the transaxle case.
5. Coat the oil seal lip with transaxle oil.
6. Insert the drive shaft and joint shaft to the transaxle. (See 03-13-3 JOINT SHAFT REMOVAL/INSTALLATION.) (See 03-13-9 DRIVE SHAFT REMOVAL/INSTALLATION.)
7. Add the specified amount and type of transaxle oil. (See 05-15B-2 TRANSAXLE OIL REPLACEMENT [G15M-R].)

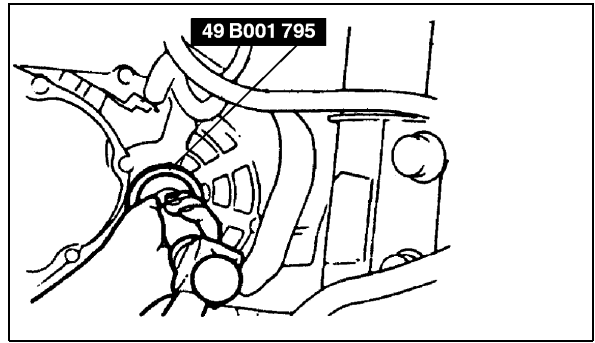

U3U51503

05-15B

# MANUAL TRANSAXLE [G15M-R]

A3U051501029W02

## MANUAL TRANSAXLE (MTX) REMOVAL/INSTALLATION [G15M-R]

1. Remove the battery, battery cover, and battery tray.
2. Remove the fresh-air duct and air cleaner component.
3. Remove the wheels and tires and splash shields.
4. Remove the EGR pipe, front pipe and TWC. (See 01-15-1 EXHAUST SYSTEM REMOVAL/INSTALLATION.)
5. Drain the transaxle oil into a container.
6. Remove the starter. (See 01-19-1 STARTER REMOVAL/INSTALLATION.)
7. Remove in the order indicated in the table.
8. Install in the reverse order of removal.
9. Add the specified amount of the specified transaxle oil. (See 05-15B-2 TRANSAXLE OIL REPLACEMENT [G15M-R].)
10. Warm up the engine and transaxle, inspect for oil leakage, and inspect the transaxle operation.

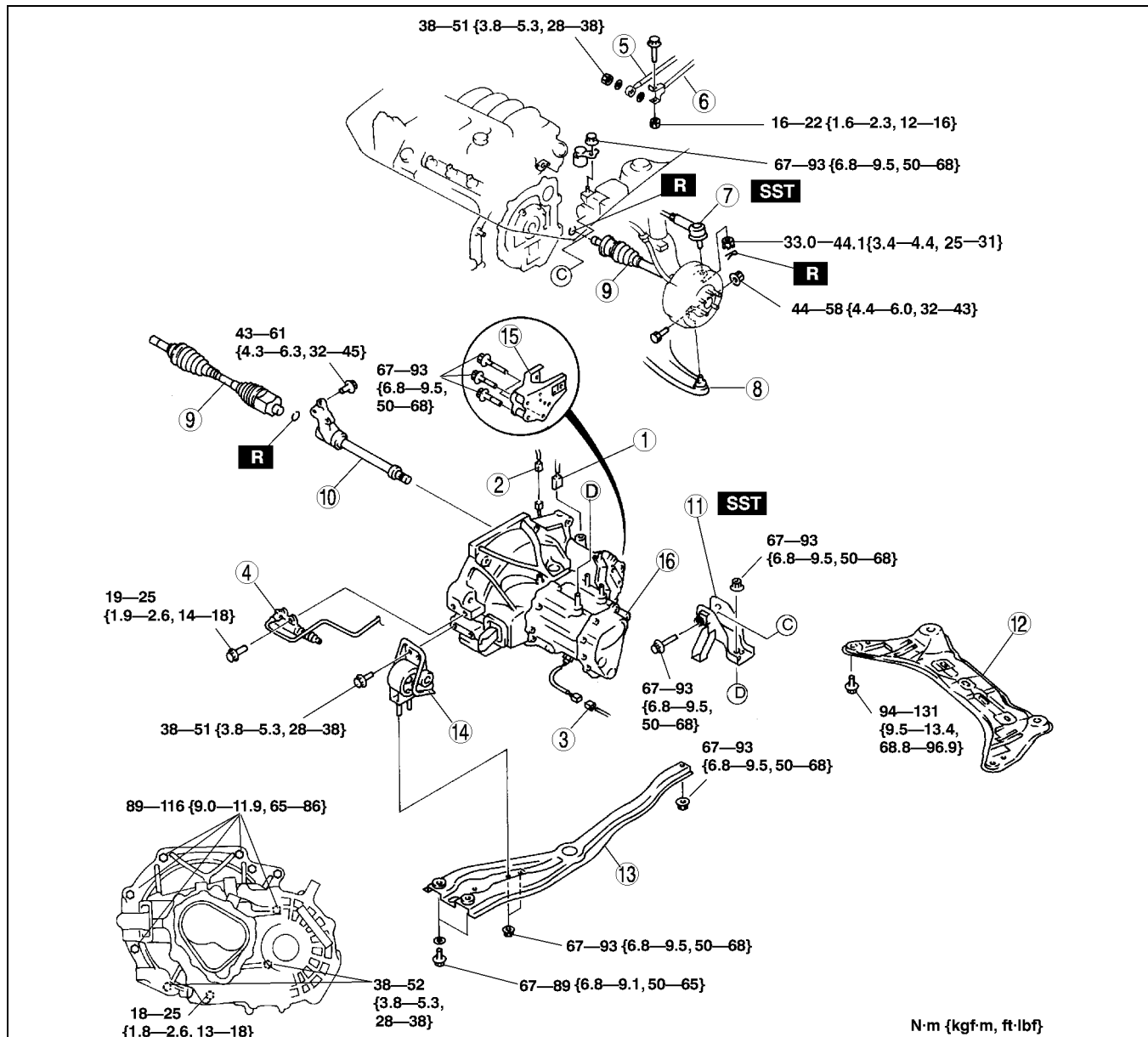

A3U0515W006

1	Speedometer sensor connector
2	Neutral switch connector
3	Back-up light switch connector
4	Clutch release cylinder
5	Extension bar
6	Change control rod

7	Tie-rod end ball joint (See 06-12-9 STEERING GEAR AND LINKAGE REMOVAL/INSTALLATION.)
8	Lower arm ball joint (See 05-15B-5 Lower Arm Ball Joint Removal Note.)
9	Drive shaft (See 03-13-9 DRIVE SHAFT REMOVAL/INSTALLATION.)

## MANUAL TRANSAXLE [G15M-R]

10	Joint shaft (See 03-13-3 JOINT SHAFT REMOVAL/ INSTALLATION.)
11	No.4 engine mount bracket (See 05-15B-5 No.4 Engine Mount Bracket Removal Note.)
12	Transverse member (See 02-13-9 TRANSVERSE MEMBER (ZM (ATX), FS) REMOVAL/INSTALLATION.)
13	Engine mount member (See 05-15B-6 Engine Mount Member Installation Note.)

14	No.2 engine mount
15	No.1 engine mount bracket
16	MTX (See 05-15B-5 Manual Transaxle (MTX) Removal Note.) (See 05-15B-6 Manual Transaxle (MTX) Installation Note.)

### Lower Arm Ball Joint Removal Note

#### Caution

- Wrap a rag around the ball joint dust seal to protect it from getting damages.

1. Pry the lower arm out of the knuckle.

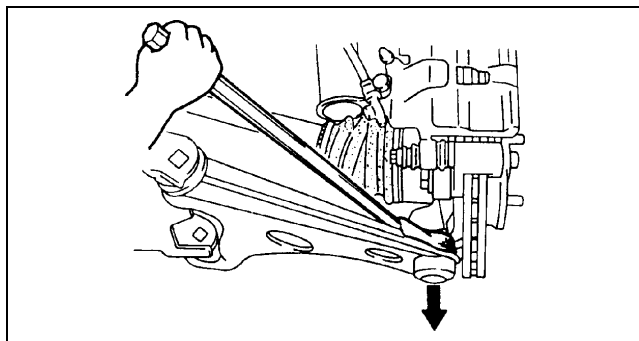

X3U515WA4

05-15B

### No.4 Engine Mount Bracket Removal Note

1. Support the engine using the **SST** before removing the No.4 engine mount bracket.
2. Remove the No.4 engine mount bracket.

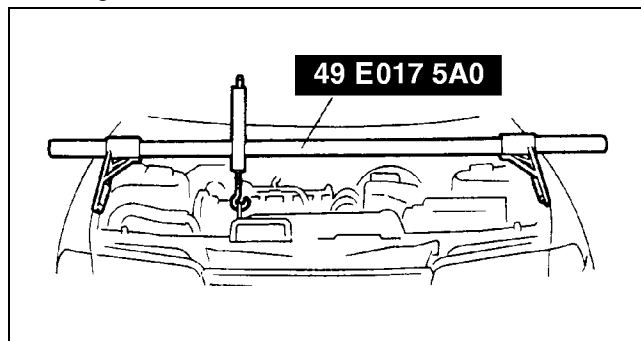

Z3U110WFK

### Manual Transaxle (MTX) Removal Note

1. Loosen the **SST** (49 E017 5A0) and lean the engine toward the transaxle.
2. Support the transaxle on a jack.
3. Remove the transaxle mounting bolts.
4. Remove the transaxle.

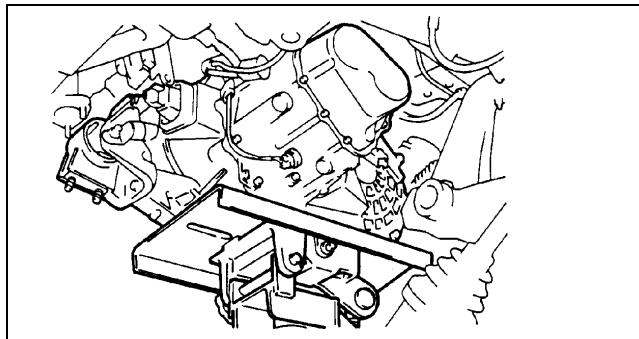

X3U515WA6



# MANUAL TRANSAXLE [G15M-R]

## Manual Transaxle (MTX) Installation Note

1. Set the transaxle on a jack and lift into place.
2. Install the transaxle mounting bolts.

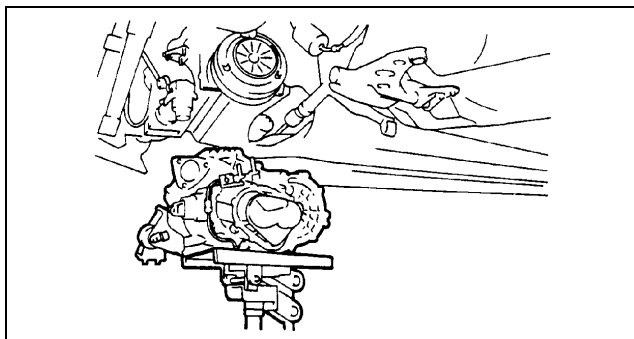

X3U515WA7

## Engine Mount Member Installation Note

1. Verify that the engine mount rubbers are installed as shown.
2. Put the No.2 engine mount stud bolts in the installation holes when installing the engine mount member.

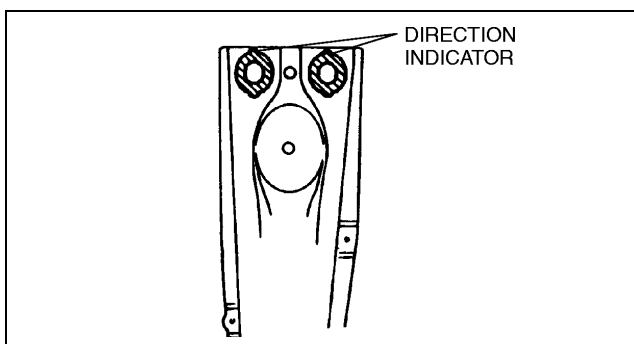

X3U515WA8

3. Tighten bolt A and nut B.

### Tightening torque

**Bolt A: 67—89 N·m {6.8—9.1 kgf·m, 50—65 ft·lbf}**

**Nut B: 67—93 N·m {6.8—9.5 kgf·m, 50—68 ft·lbf}**

4. Tighten nuts C.

### Tightening torque

**Nut C: 67—93 N·m {6.8—9.5 kgf·m, 50—68 ft·lbf}**

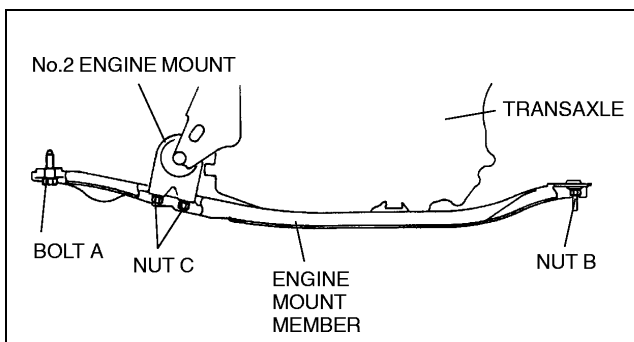

X3U515WA9

5. By aligning the holes with the stud bolts, install the No.4 engine mount bracket to the transaxle.
6. Align the hole of the No.4 engine mount bracket with the No.4 engine mount rubber on vehicle, and temporarily tighten bolt D.
7. Tighten nuts E, then bolt D.

### Tightening torque

**Bolt D and nut E: 67—93 N·m {6.8—9.5 kgf·m, 50—68 ft·lbf}**

8. Remove the **SST** (49 E017 5A0).

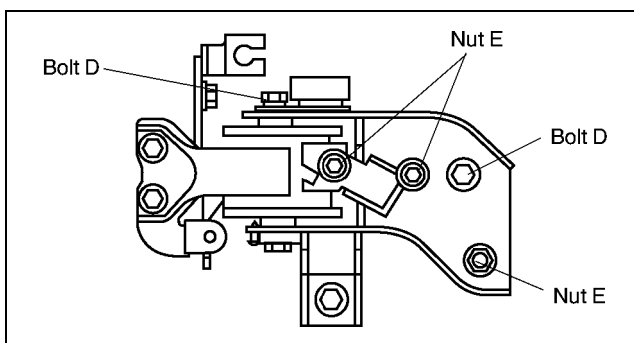

Y3E5212W003

## 05-16 MANUAL TRANSAXLE SHIFT MECHANISM

SHIFT MECHANISM

REMOVAL/INSTALLATION ..... 05-16-2

---

# MANUAL TRANSAXLE SHIFT MECHANISM

A3U051646010W01

## SHIFT MECHANISM REMOVAL/INSTALLATION

1. Remove the front console. (See 09-17-5 CONSOLE REMOVAL/INSTALLATION.)
2. Remove the TWC. (See 01-15-1 EXHAUST SYSTEM REMOVAL/INSTALLATION.)
3. Remove in the order indicated in the table.
4. Install in the reverse order of removal.
5. After installation, verify that the gear shift lever operates smoothly when the clutch pedal is depressed.

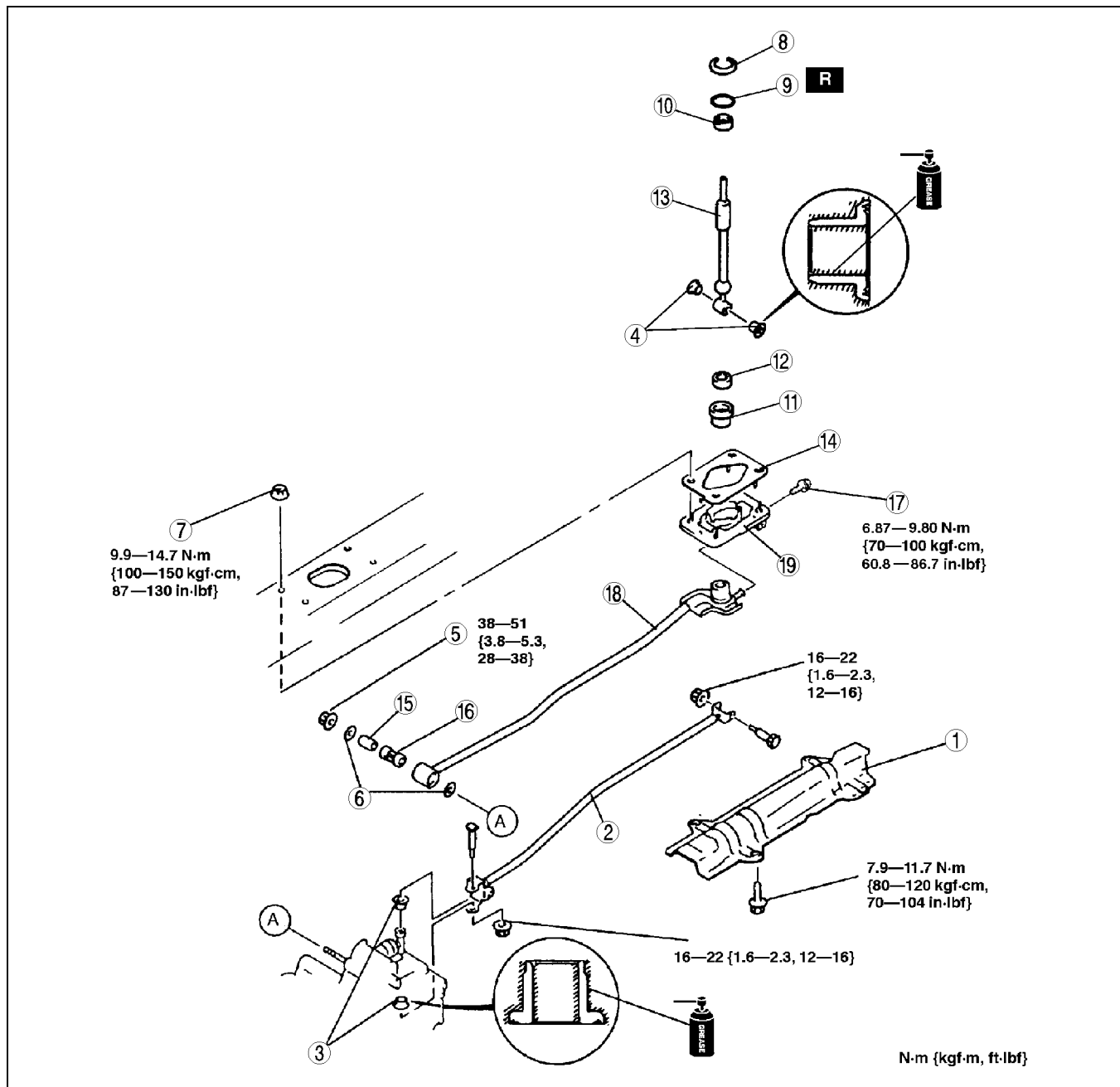

Z3U516W01

1	Heat insulator
2	Change control rod
3	Bushing
4	Bushing
5	Nut
6	Washer
7	Nut
8	Retaining ring
9	O-ring
10	Upper ball seat

11	Boot
12	Lower ball seat
13	Gear shift lever
14	Seal rubber
15	Pipe
16	Bushing
17	Bolt
18	Extension bar
19	Base plate

# 05-17 AUTOMATIC TRANSAXLE

<b>AUTOMATIC TRANSAXLE</b>		<b>VEHICLE SPEEDOMETER SENSOR</b>	
<b>LOCATION INDEX</b> .....	05-17-2	<b>(VSS) INSPECTION [ATX]</b> .....	05-17-27
<b>AUTOMATIC TRANSAXLE (ATX)</b>		Visual Inspection .....	05-17-27
<b>CROSS-SECTIONAL VIEW</b> .....	05-17-4	Wave profile Inspection .....	05-17-27
<b>SYSTEM WIRING DIAGRAM</b> .....	05-17-6	Power Supply Voltage Inspection .....	05-17-27
ZM Engine .....	05-17-6	Open Circuit Inspection.....	05-17-27
FS Engine .....	05-17-8	Short Circuit Inspection.....	05-17-28
<b>AUTOMATIC TRANSAXLE (ATX)</b>		Sensor Rotor Inspection .....	05-17-28
<b>POWERTRAIN STRUCTURAL VIEW.</b> ..	05-17-10	<b>VEHICLE SPEEDOMETER SENSOR</b>	
EC-AT Operation Chart .....	05-17-11	<b>(VSS) REMOVAL/INSTALLATION</b>	
<b>MECHANICAL SYSTEM TEST</b> .....	05-17-11	<b>[ATX]</b> .....	05-17-28
Mechanical System Test Preparation .	05-17-11	<b>SOLENOID VALVES INSPECTION</b> . . . .	05-17-28
Line Pressure Test.....	05-17-12	Inspection of Resistance (On-vehicle) .	05-17-28
Stall Test .....	05-17-13	Inspection of Operation.....	05-17-29
Time Lag Test .....	05-17-14	Resistance Inspection (Off-vehicle) . .	05-17-29
<b>ROAD TEST</b> .....	05-17-14	<b>SOLENOID VALVES</b>	
Road Test Preparation.....	05-17-14	<b>REMOVAL/INSTALLATION</b> .....	05-17-30
Shift Diagram .....	05-17-15	<b>O/D OFF INDICATOR LIGHT</b>	
Vehicle speed at shift point table . . . .	05-17-16	<b>INSPECTION</b> .....	05-17-30
D Range Test.....	05-17-16	Inspection of Operation.....	05-17-30
2 Range Test .....	05-17-17	<b>PCM INSPECTION</b> .....	05-17-30
1 Range Test .....	05-17-17	<b>PCM REMOVAL/INSTALLATION</b> .....	05-17-30
P Position Test.....	05-17-17	<b>AUTOMATIC TRANSAXLE (ATX)</b>	
<b>AUTOMATIC TRANSAXLE FLUID (ATF)</b>		<b>REMOVAL/INSTALLATION</b> .....	05-17-31
<b>INSPECTION</b> .....	05-17-17	Lower Arm Removal Note.....	05-17-33
Automatic Transaxle Fluid (ATF)		Torque Converter Installation Nuts	
Condition Inspection .....	05-17-17	Removal Note .....	05-17-34
Automatic Transaxle Fluid (ATF)		No.4 Engine Mount Removal Note . . . .	05-17-34
Level Inspection.....	05-17-18	Transaxle Removal Note.....	05-17-34
<b>AUTOMATIC TRANSAXLE FLUID (ATF)</b>		Transaxle Installation Note .....	05-17-35
<b>REPLACEMENT</b> .....	05-17-18	No.2 Engine Mount, Engine Mounting	
<b>O/D OFF SWITCH INSPECTION</b> .....	05-17-19	Member, No.4 Engine Mount	
Inspection of Operation .....	05-17-19	Installation Note .....	05-17-35
Inspection of Voltage .....	05-17-19	<b>OIL SEAL (TRANSAXLE)</b>	
Inspection of Continuity .....	05-17-19	<b>REPLACEMENT</b> .....	05-17-36
<b>O/D OFF SWITCH</b>		<b>CONTROL VALVE BODY</b>	
<b>REMOVAL/INSTALLATION</b> .....	05-17-19	<b>REMOVAL/INSTALLATION</b> .....	05-17-36
<b>TRANSAXLE RANGE (TR) SWITCH</b>		On-vehicle Removal .....	05-17-36
<b>INSPECTION</b> .....	05-17-20	On-vehicle Installation.....	05-17-38
Inspection of Operation .....	05-17-20	<b>OIL COOLER FLUSHING</b> .....	05-17-40
Inspection of Continuity .....	05-17-20	Power Flushing .....	05-17-40
<b>TRANSAXLE RANGE (TR) SWITCH</b>		<b>OIL COOLER</b>	
<b>REMOVAL/INSTALLATION</b> .....	05-17-20	<b>REMOVAL/INSTALLATION</b> .....	05-17-41
<b>TRANSAXLE RANGE (TR) SWITCH</b>		Radiator Lower Tank (In Tank Oil	
<b>ADJUSTMENT</b> .....	05-17-23	Cooler) Removal Note.....	05-17-42
<b>TRANSAXLE FLUID TEMPERATURE</b>		Radiator Lower Tank (In Tank Oil	
<b>(TFT) SENSOR INSPECTION</b> .....	05-17-25	Cooler) Installation Note .....	05-17-43
<b>TRANSAXLE FLUID TEMPERATURE</b>		Radiator Installation Note .....	05-17-45
<b>(TFT) SENSOR</b>		Oil Hose Installation Note .....	05-17-45
<b>REMOVAL/INSTALLATION</b> .....	05-17-25	<b>DRIVE PLATE</b>	
<b>INPUT/TURBINE SPEED SENSOR</b>		<b>REMOVAL/INSTALLATION</b> .....	05-17-46
<b>INSPECTION</b> .....	05-17-26	Drive Plate Mounting Bolts	
Resistance Inspection .....	05-17-26	Removal Note .....	05-17-46
<b>INPUT/TURBINE SPEED SENSOR</b>		Drive Plate Mounting Bolts	
<b>REMOVAL/INSTALLATION</b> .....	05-17-26	Installation Note .....	05-17-46

05-17

# AUTOMATIC TRANSAXLE

## AUTOMATIC TRANSAXLE LOCATION INDEX

A3U051701030W01

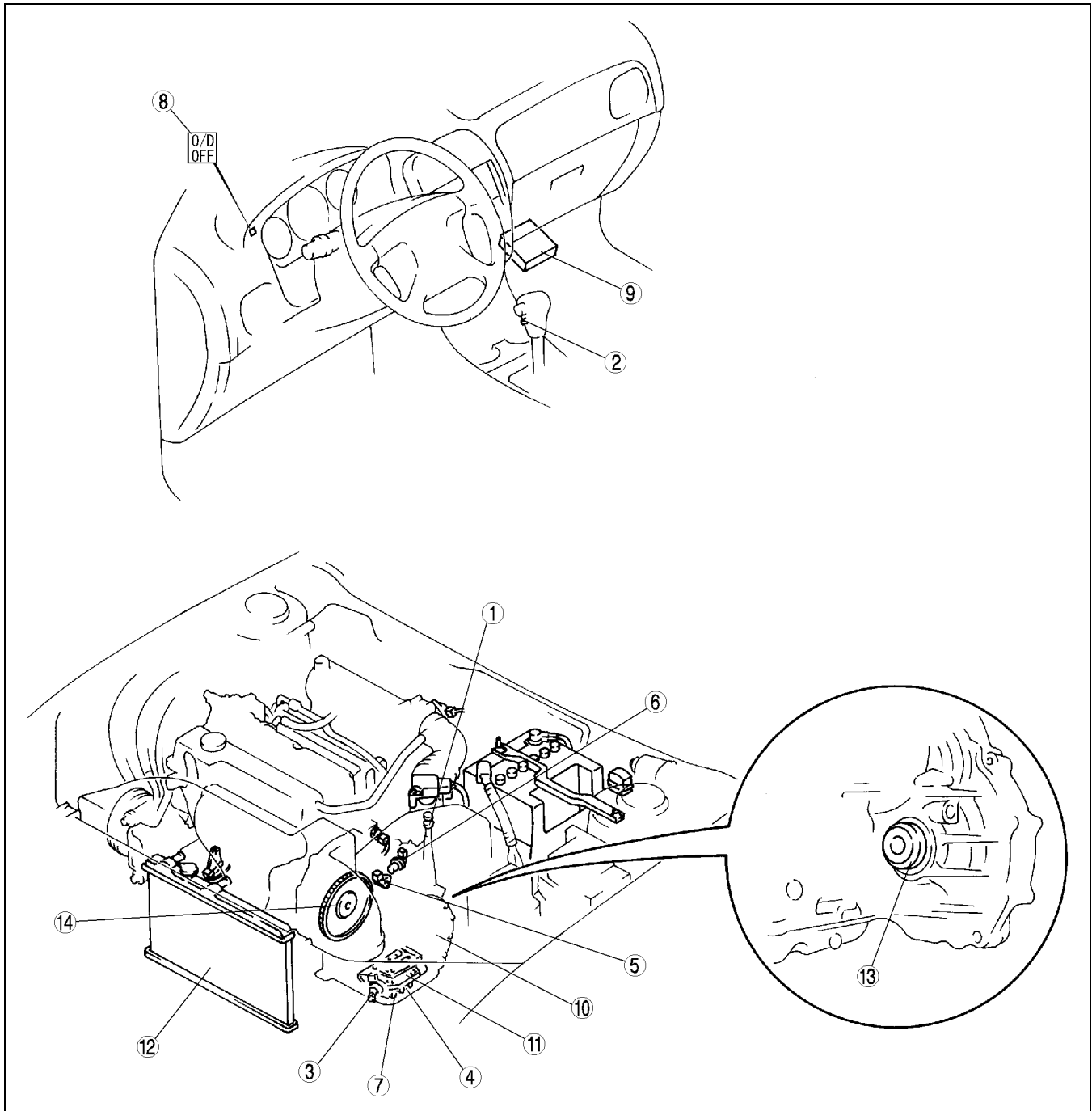

Z3U517W01

1	ATF (See 05-17-17 AUTOMATIC TRANSAXLE FLUID (ATF) INSPECTION.) (See 05-17-18 AUTOMATIC TRANSAXLE FLUID (ATF) REPLACEMENT.)
2	O/D OFF switch (See 05-17-19 O/D OFF SWITCH INSPECTION) (See 05-17-19 O/D OFF SWITCH REMOVAL/INSTALLATION)
3	TR switch (See 05-17-20 TRANSAXLE RANGE (TR) SWITCH INSPECTION) (See 05-17-20 TRANSAXLE RANGE (TR) SWITCH REMOVAL/INSTALLATION) (See 05-17-23 TRANSAXLE RANGE (TR) SWITCH ADJUSTMENT)

4	TFT sensor (See 05-17-25 TRANSAXLE FLUID TEMPERATURE (TFT) SENSOR REMOVAL/INSTALLATION) (See 05-17-25 TRANSAXLE FLUID TEMPERATURE (TFT) SENSOR INSPECTION)
5	Input/turbine speed sensor (See 05-17-26 INPUT/TURBINE SPEED SENSOR INSPECTION) (See 05-17-26 INPUT/TURBINE SPEED SENSOR REMOVAL/INSTALLATION)
6	Vehicle speedometer sensor (without ABS) (See 05-17-28 VEHICLE SPEEDOMETER SENSOR (VSS) REMOVAL/INSTALLATION [ATX]) (See 05-17-27 VEHICLE SPEEDOMETER SENSOR (VSS) INSPECTION [ATX])

## AUTOMATIC TRANSAXLE

7	Solenoid valve (See 05-17-28 SOLENOID VALVES INSPECTION) (See 05-17-30 SOLENOID VALVES REMOVAL/INSTALLATION)
8	O/D OFF indicator light (See 05-17-30 O/D OFF INDICATOR LIGHT INSPECTION)
9	PCM (See 05-17-30 PCM REMOVAL/INSTALLATION)
10	Transaxle (See 05-17-31 AUTOMATIC TRANSAXLE (ATX) REMOVAL/INSTALLATION)
11	Control valve body (See 05-17-36 CONTROL VALVE BODY REMOVAL/INSTALLATION)

12	Oil cooler (See 05-17-40 OIL COOLER FLUSHING) (See 05-17-41 OIL COOLER REMOVAL/INSTALLATION)
13	Oil seal (transaxle) (See 05-17-36 OIL SEAL (TRANSAXLE) REPLACEMENT)
14	Drive plate (See 05-17-46 DRIVE PLATE REMOVAL/INSTALLATION)

# AUTOMATIC TRANSAXLE

## AUTOMATIC TRANSAXLE (ATX) CROSS-SECTIONAL VIEW

A3U051701030W02

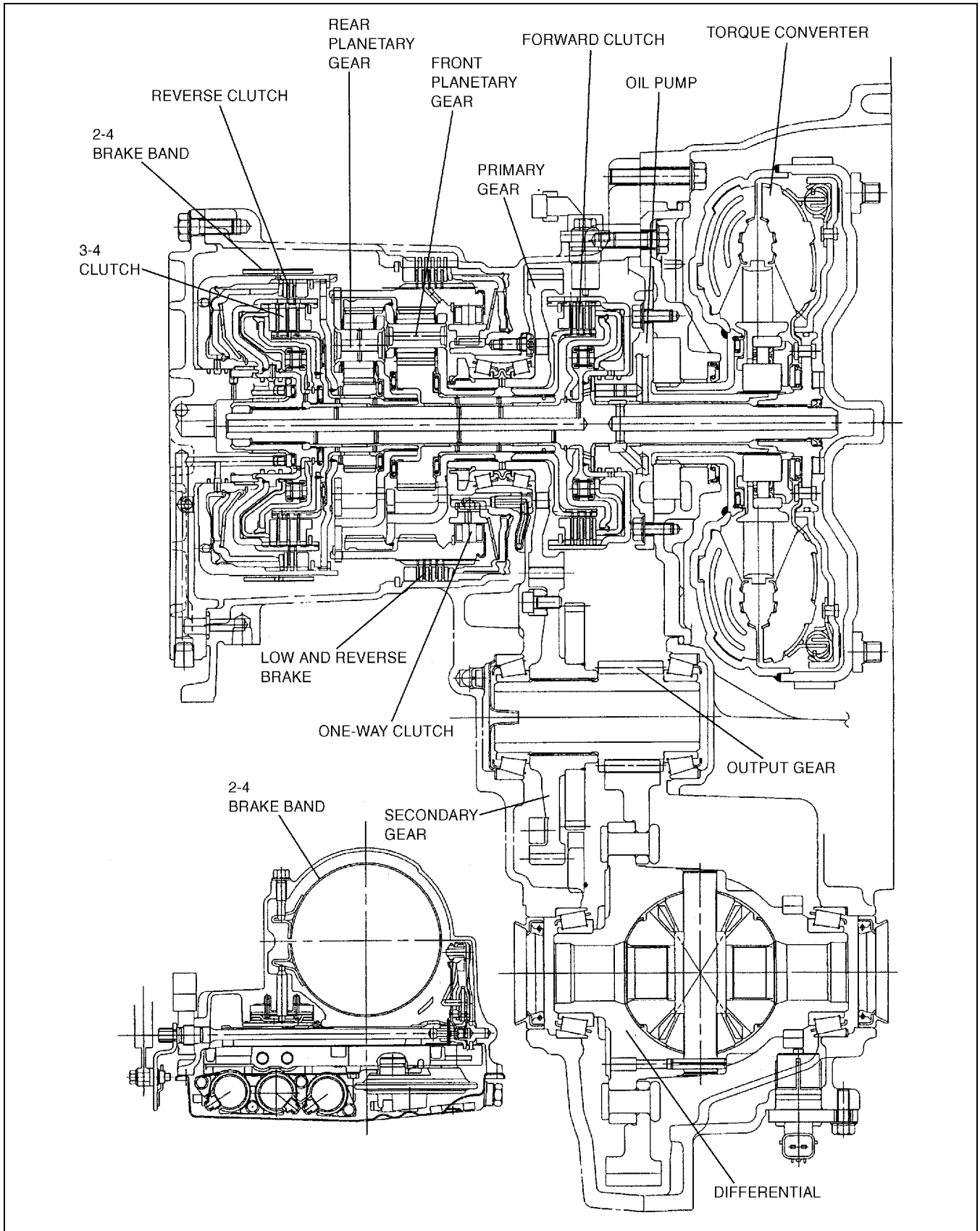

Y3U517WA0





# AUTOMATIC TRANSAXLE

## SYSTEM WIRING DIAGRAM

ZM Engine

A3U051701030W03

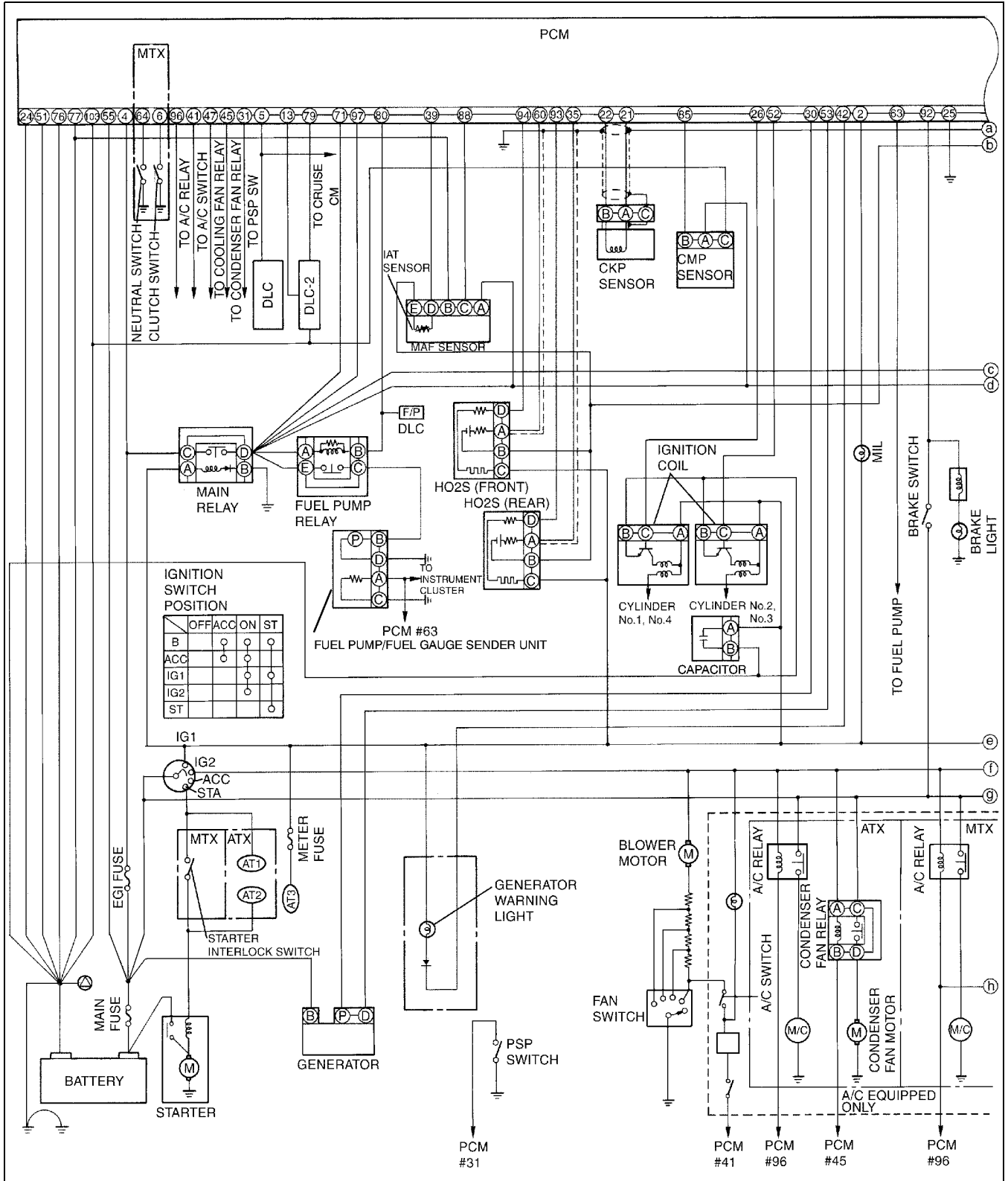

# AUTOMATIC TRANSAXLE

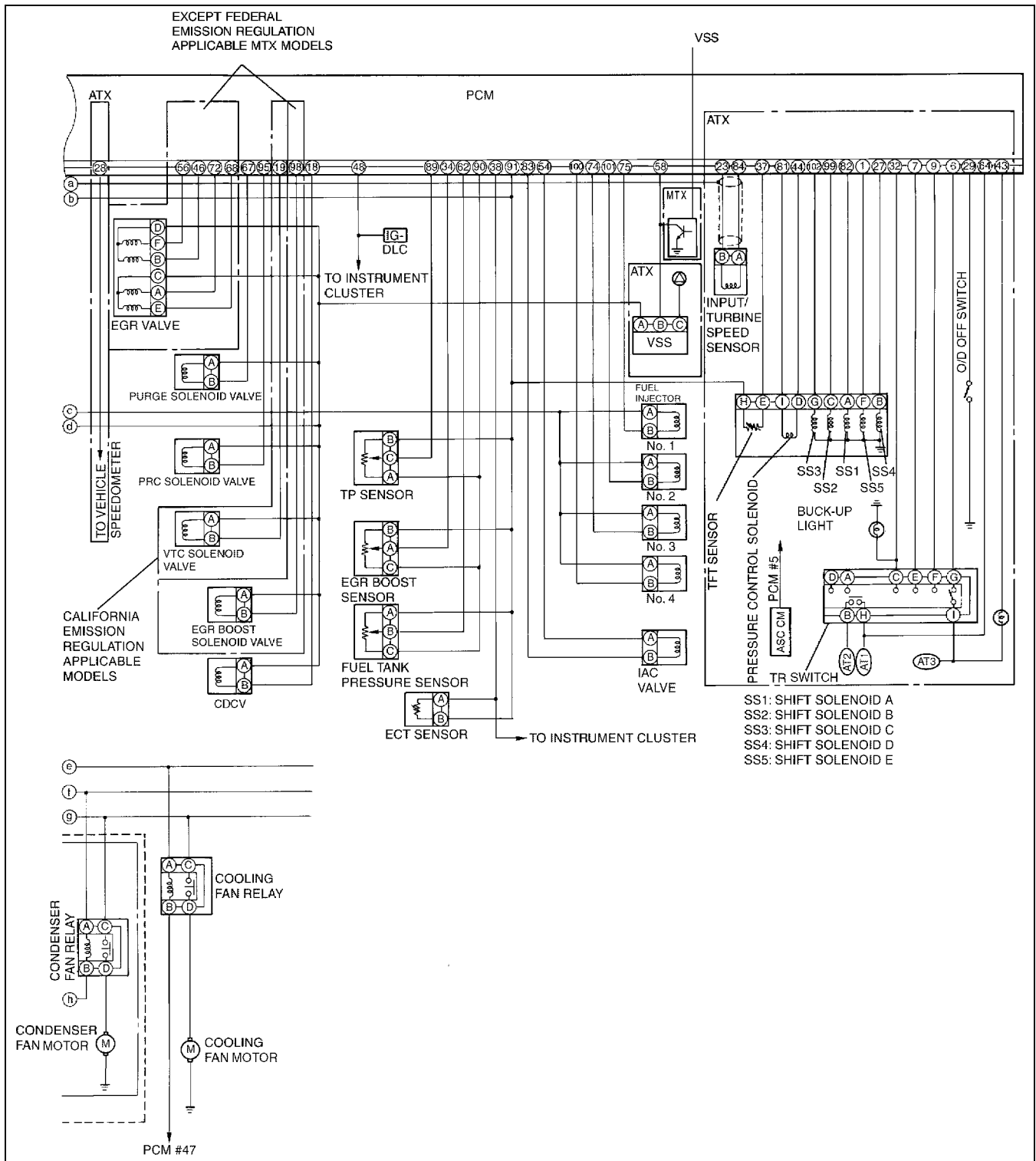

05-17

Y3U517WA1

# AUTOMATIC TRANSAXLE

FS Engine

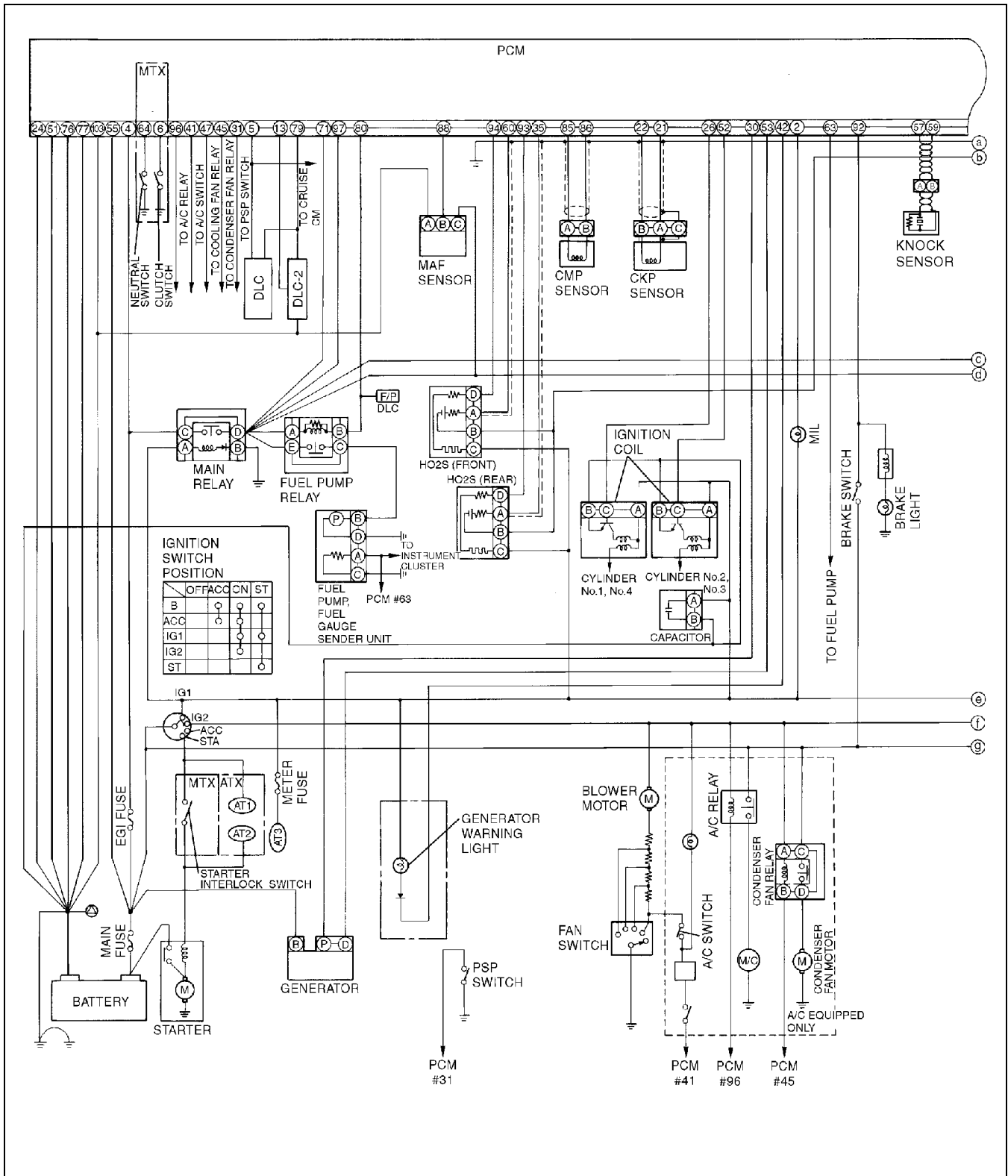

Z3U0140W103

# AUTOMATIC TRANSAXLE

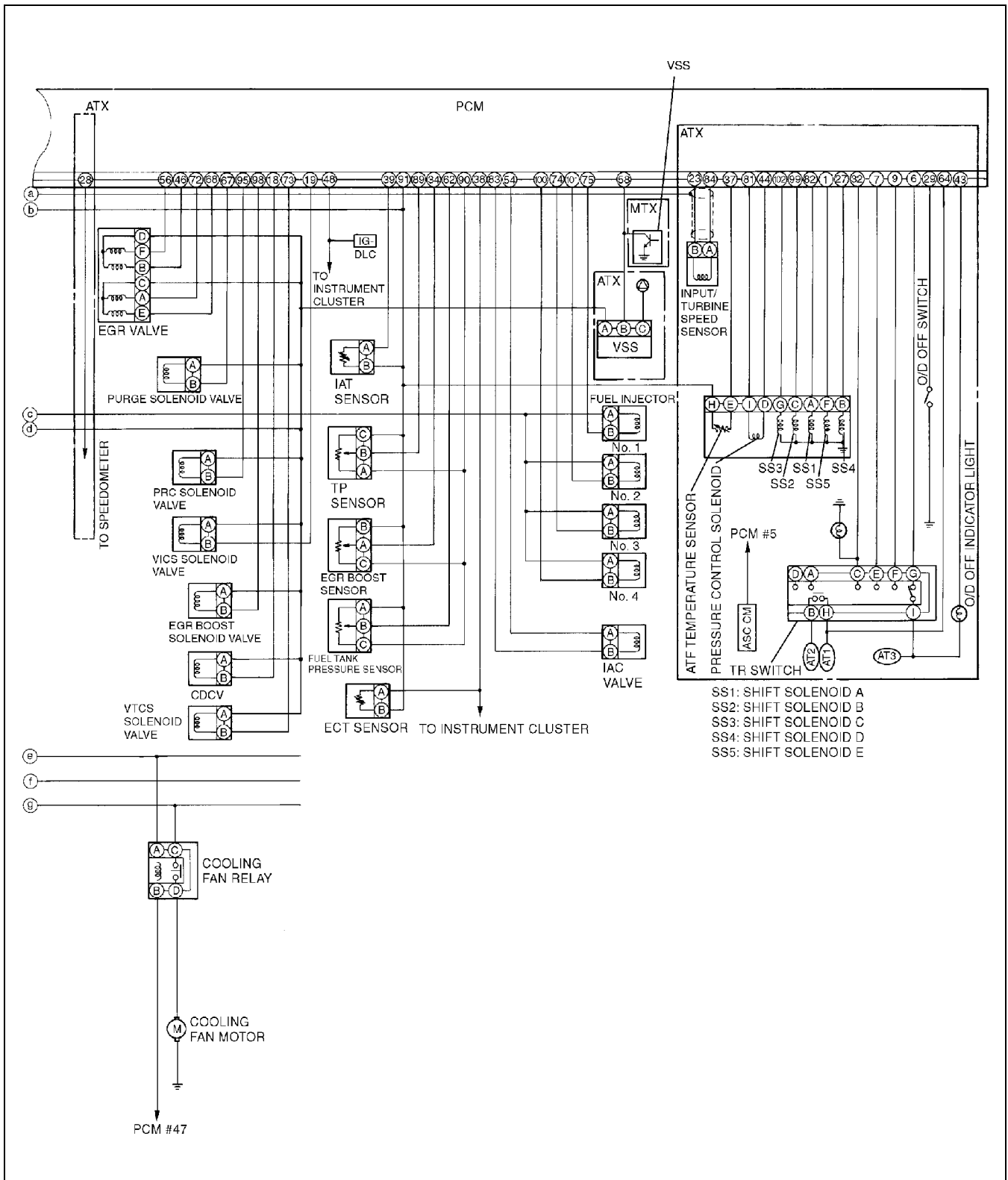

05-17

Z3U0140W104

# AUTOMATIC TRANSAXLE

## AUTOMATIC TRANSAXLE (ATX) POWERTRAIN STRUCTURAL VIEW

A3U051701030W04

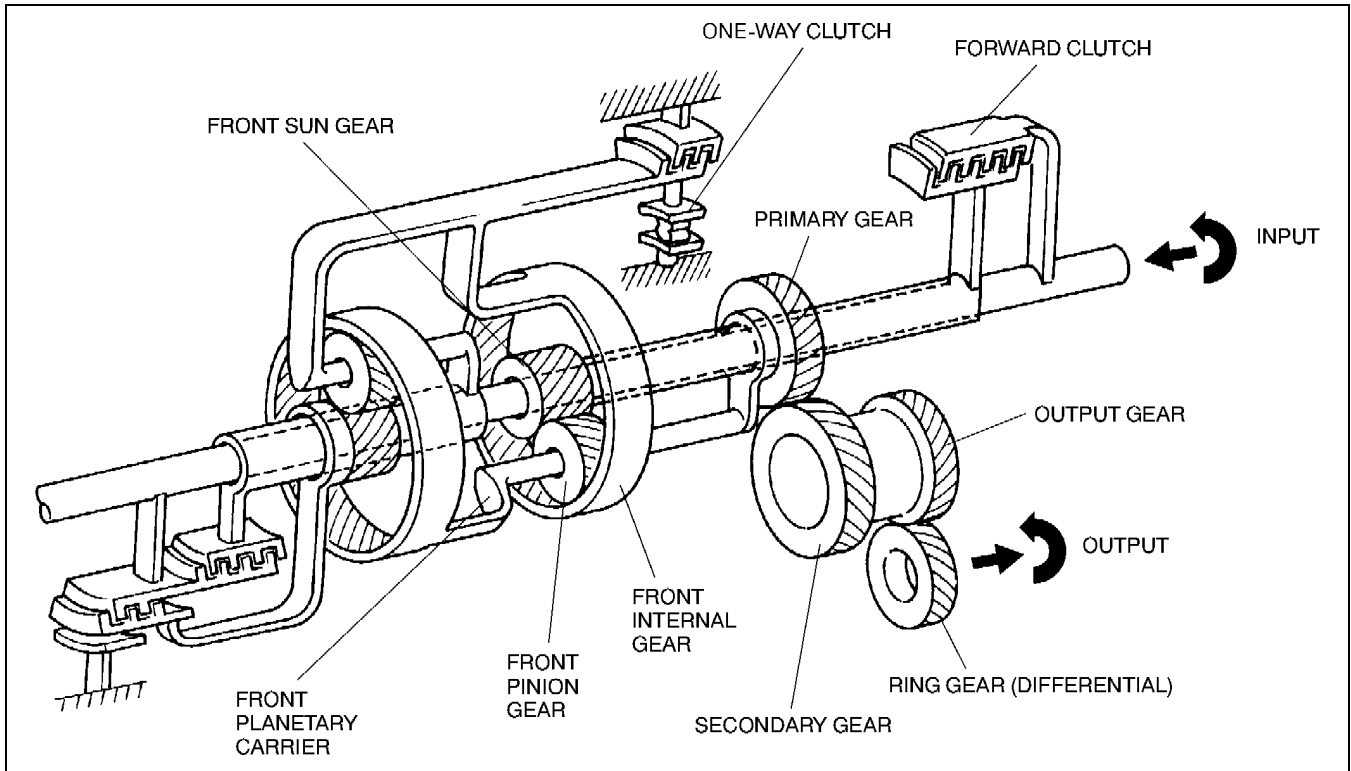

Y3U517WA3

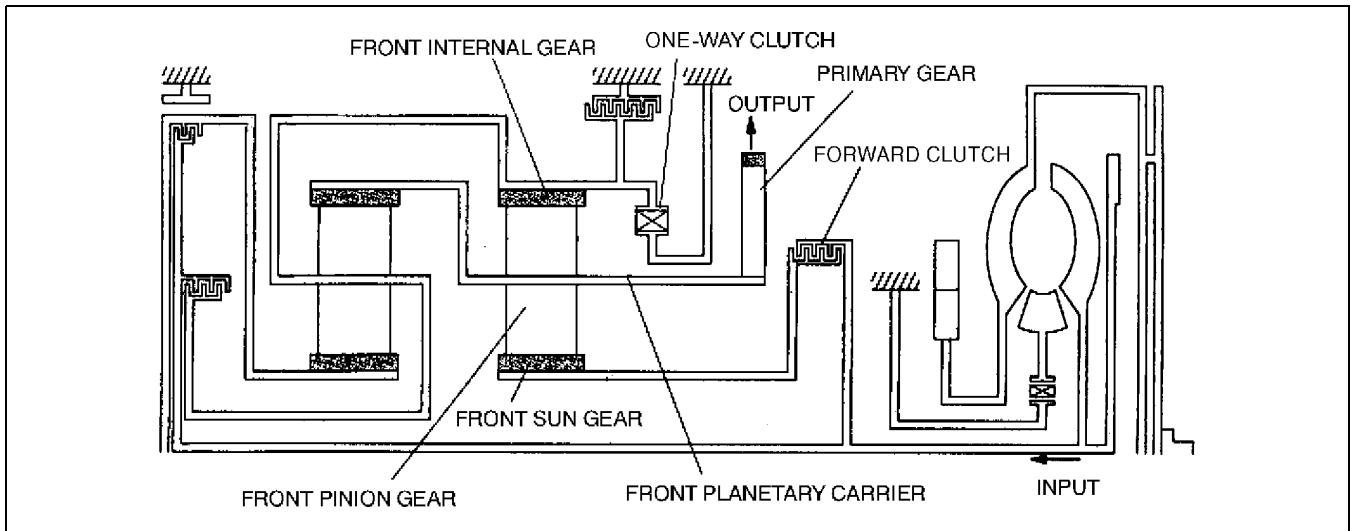

Y3U517WA4

# AUTOMATIC TRANSAXLE

## EC-AT Operation Chart

Position/Range	Mode	Gear position		Shift pattern			Transaxle					Operation of shift solenoid								
				Shift	TCC	Engine brake	Forward clutch	3-4 clutch	Reverse clutch	2-4 brake band		Low and reverse brake	One-way clutch	Solenoid valve (duty-cycle type)			Solenoid valve (ON/OFF type)			
										Applied	Released			Shift solenoid A	Shift solenoid B	Shift solenoid C	Shift solenoid D	Shift solenoid E		
P	-	Neutral	-	-											-	-	-	ON	OFF	
R	-	Reverse	2.648	-		×			×			×			OPEN	OPEN	OPEN	OFF	OFF	
N	-	Neutral	-	-											-	-	-	ON	OFF	
D	*1 POWER/ NORMAL	1GR	2.816	↕			×							×	*4	OPEN	CLOSE	CLOSE	OFF	OFF
		2GR	1.497	↕			×	×			×					OPEN	OPEN	CLOSE	OFF	OFF
		3GR	1.000	↕			×	×	×		×	×				OPEN	OPEN	OPEN	OFF	OFF
		4GR	0.725	↕			×		×		×					CLOSE	OPEN	OPEN	ON	OFF
		4GR *2 TCC ON	0.725		×	×		×								CLOSE	OPEN	OPEN	ON	ON
2	-	2GR	1.497	↑			×	×		×					OPEN	OPEN	CLOSE	OFF	OFF	
		3GR*3	1.000	↑			×	×	×		×	×			OPEN	OPEN	OPEN	OFF	OFF	
		4GR*3	0.725	↑			×		×		×				CLOSE	OPEN	OPEN	ON	OFF	
1	-	1GR	2.816	↑			×	×					×	×	*4	OPEN	OPEN	CLOSE	ON	ON
		2GR*3	1.497	↑			×	×			×					OPEN	OPEN	CLOSE	OFF	OFF
		3GR*3	1.000	↑			×	×	×		×	×				OPEN	OPEN	OPEN	OFF	OFF
		4GR*3	0.725	↑			×		×		×					CLOSE	OPEN	OPEN	ON	OFF

05-17

- \*1: Automatically switches between POWER and NORMAL modes according to accelerator pedal depressing speed
- \*2: Performs TCC operation in NORMAL mode
- \*3: Engine overspeed protection
- \*4: Transmits the torque only when driving
- \*5: Indicates operation although the band servo remains deactivated due to the large area of the release pressure side.
- ×: Operating
- \*: Transmits the torque only when driving
- OPEN: Engages the line pressure to the clutch pressure (Solenoid de-energized)
- CLOSE: Drains the clutch pressure (Solenoid energized)
- ON: Engages the output port and the supply port (Solenoid reducing pressure)
- OFF: Engages the output port and the drain port (Drains the output port)

Y3U517WAP

### MECHANICAL SYSTEM TEST

A3U051701030W05

#### Mechanical System Test Preparation

1. Apply the parking brake and use wheel chocks at the front and rear of the wheels.
2. Inspect the engine coolant. (See 01-12-2 COOLING SYSTEM SERVICE WARNINGS.) (See 01-12-2 ENGINE COOLANT LEVEL INSPECTION.)
3. Inspect the engine oil. (See 01-11-2 ENGINE OIL INSPECTION.)
4. Inspect the ATF levels. (See 05-17-18 Automatic Transaxle Fluid (ATF) Level Inspection.)
5. Inspect the ignition timing. (See 01-10A-25 Ignition Timing Inspection.) (See 01-10B-25 Ignition Timing Inspection.)
6. Inspect the idle speed. (See 01-10A-26 Idle Speed Adjustment.) (See 01-10B-26 Idle Speed Adjustment.)

# AUTOMATIC TRANSAXLE

## Line Pressure Test

1. Perform mechanical system test preparation. (See 05–17–11 Mechanical System Test Preparation.)

### Warning

- Removing the square-head plug when the ATF is hot can be dangerous. Hot ATF can come out of the opening and badly burn you. Before removing the square-head plug, allow the ATF to cool.

2. Connect the **SSTs** (49 0378 400C, 49 B019 901B and 49 H019 002) to the line pressure inspection port.
3. Start the engine and shift the selector lever to D range and read the line pressure at idle.

### Warning

- Removing the **SST** when the ATF is hot can be dangerous. Hot ATF can come out of the opening and badly burn you. Before removing the **SST**, allow the ATF to cool.

4. Turn the engine off and remove the **SST** (49 B019 901B), and replace the gauge part of the **SST** (49 B019 902).

### Caution

- Do not maintain **WOT** in any position/range for more than 5 seconds, or transaxle damage will occur.

5. Start the engine and firmly depress the brake pedal with the left foot, and then depress the accelerator pedal to floor (**WOT**) with the right.
6. When the engine speed no longer increases, quickly read the line pressure and release the accelerator pedal.
7. Shift the selector lever to N position and let the engine idle for **1 minute** or more to cool the ATF.
8. Read the line pressure at idle and at the engine stall speed for the 2, and 1 ranges and R position in the same manner.

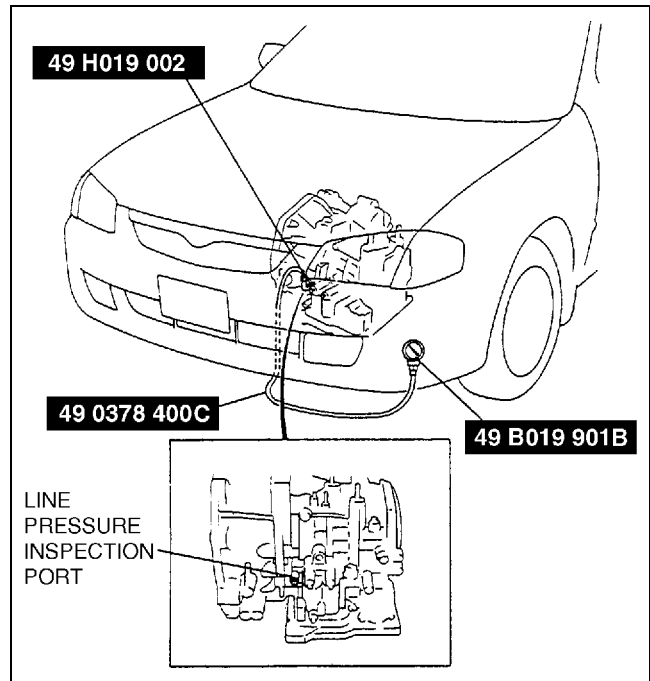

Z3U502W02

## Line pressure specification

Position /range	Line pressure kPa {kgf/cm <sup>2</sup> , psi}			
	Idle		Stall	
	ZM	FS	ZM	FS
D, 2, 1	330—470 {3.4—4.7, 49—66}		1,200—1,360 {12.3—13.8, 175—196}	1,160—1,320 {11.9—13.4, 170—190}
R	490—710 {5.0—7.2, 72—100}		1,470—1,690 {15.0—17.2, 214—244}	

9. Shift the selector lever to P position and turn off the engine.

### Warning

- Removing the **SST** when the ATF is hot can be dangerous. Hot ATF can come out of the opening and badly burn you. Before removing the **SST**, allow the ATF to cool.

10. Remove the **SST**.
11. Install a new square head plug in the inspection port.

### Tightening torque

4.91—9.80 N·m {50—100 kgf·cm, 43.4—86.7 in·lbf}

## AUTOMATIC TRANSAXLE

### Evaluation of line pressure test

Condition	Possible cause
Low pressure in all positions/ranges	<ul style="list-style-type: none"> <li>• Worn oil pump</li> <li>• Oil leaking from oil pump, control valve body, and/or transaxle case</li> <li>• Pressure regulator valve stuck</li> <li>• Pressure control solenoid malfunction</li> <li>• Solenoid reducing valve stuck</li> </ul>
Low pressure in D, 2, 1 only	<ul style="list-style-type: none"> <li>• Oil leaking from forward clutch hydraulic circuit</li> </ul>
Low pressure in 2 only	<ul style="list-style-type: none"> <li>• Oil leaking from 2-4 brake band hydraulic circuit</li> </ul>
Low pressure in 1, R only	<ul style="list-style-type: none"> <li>• Oil leaking from low and reverse brake hydraulic circuit</li> </ul>
Low pressure in R only	<ul style="list-style-type: none"> <li>• Oil leaking from reverse clutch hydraulic circuit</li> </ul>
Higher pressure in all positions/ranges	<ul style="list-style-type: none"> <li>• Pressure control solenoid malfunction and/or open harness</li> <li>• Pressure regulator valve stuck</li> <li>• PCM malfunction</li> </ul>

### Stall Test

1. Perform mechanical system test preparation. (See 05–17–11 Mechanical System Test Preparation.)
2. Start the engine and shift the selector lever to R position.

#### Caution

- **Do not maintain WOT in any position/range for more than 5 seconds, or transaxle damage will occur.**

3. Firmly depress the brake pedal with the left foot, and depress the accelerator pedal to floor (WOT) with the right.
4. When the engine speed no longer increases, quickly read the engine speed and release the accelerator pedal.
5. Shift the selector lever to N position and let the engine idle for **1 minute** or more to cool the ATF.
6. Perform stall tests of D, 2, and 1 ranges in the same manner.

#### Engine stall speed

**ZM engine: 2,300—2,600 rpm**

**FS engine: 2,200—2,500 rpm**

7. Turn off the engine.

### Evaluation of stall test

Condition	Possible cause	
Above specification	Insufficient line pressure, torque converter pressure	• Worn oil pump
		• Oil leaking from oil pump, control valve, and/or transaxle case
		• Pressure regulator valve sticking
		• Converter relief valve sticking
	In D, 2 and 1 ranges	• Pressure control solenoid malfunction
• Forward clutch slipping		
In 2 range	• 2-4 brake band slipping	
In 1 range and R position	• Low and reverse brake slipping	
In R position	<ul style="list-style-type: none"> <li>• Low and reverse brake slipping</li> <li>• Reverse clutch slipping</li> </ul> Perform road test to determine whether problem is in low and reverse brake or reverse clutch <ul style="list-style-type: none"> <li>• Engine braking felt in 1 range: Reverse clutch is defective.</li> <li>• Engine braking not felt in 1 range: Low and reverse brake is defective.</li> </ul>	
Below specification	• Engine lack of power	



# AUTOMATIC TRANSAXLE

## Time Lag Test

1. Perform mechanical system test preparation. (See 05–17–11 Mechanical System Test Preparation.)
2. Start the engine and warm up the engine until the ATF temperature reaches **60–70 °C {141– 158 °F}**.
3. Shift the selector lever from N position to D range.
4. Use a stopwatch to measure the time it takes from shifting until engagement is felt. Take 3 measurements for each test and average the results using the following formula.

**Formula**  
**Average time lag =  $\frac{\text{Time 1} + \text{Time 2} + \text{Time 3}}{3}$**

X3U517WD8

5. Perform the test for the following shifts in the same manner.
  - N position→R position

### Average time lag

**N position→D range: 0.4–0.7 sec**

**N position→R position: 0.4–0.7 sec**

## Evaluation of time lag test

Condition		Possible cause
N→D shift	More than specification	<ul style="list-style-type: none"> <li>Low line pressure</li> <li>Forward clutch slipping</li> <li>Oil leaking from forward clutch fluid circuit</li> <li>Shift solenoid A not operating properly</li> </ul>
	Less than specification	<ul style="list-style-type: none"> <li>Forward accumulator not operating properly</li> <li>Shift solenoid A not operating properly</li> <li>Excessive line pressure</li> </ul>
N→R shift	More than specification	<ul style="list-style-type: none"> <li>Low line pressure</li> <li>Low and reverse brake slipping</li> <li>Reverse clutch slipping</li> <li>Shift solenoid B not operating properly</li> </ul>
	Less than specification	<ul style="list-style-type: none"> <li>Servo apply accumulator not operating properly</li> <li>Shift solenoid B not operating properly</li> <li>Excessive line pressure</li> </ul>

## ROAD TEST

A3U051701030W06

### Road Test Preparation

1. Inspect the engine coolant. (See 01–12–2 COOLING SYSTEM SERVICE WARNINGS.) (See 01–12–2 ENGINE COOLANT LEVEL INSPECTION.)
2. Inspect the engine oil. (See 01–11–2 ENGINE OIL INSPECTION.)
3. Inspect the ATF levels. (See 05–17–18 Automatic Transaxle Fluid (ATF) Level Inspection.)
4. Inspect the ignition timing. (See 01–10A–25 Ignition Timing Inspection.) (See 01–10B–25 Ignition Timing Inspection.)
5. Inspect the idle speed. (See 01–10A–26 Idle Speed Adjustment.) (See 01–10B–26 Idle Speed Adjustment.)
6. Bring up the engine and transaxle to normal operating temperature.

# AUTOMATIC TRANSAXLE

**Shift Diagram**  
**D range (normal mode, O/D OFF switch OFF)**  
**ZM**

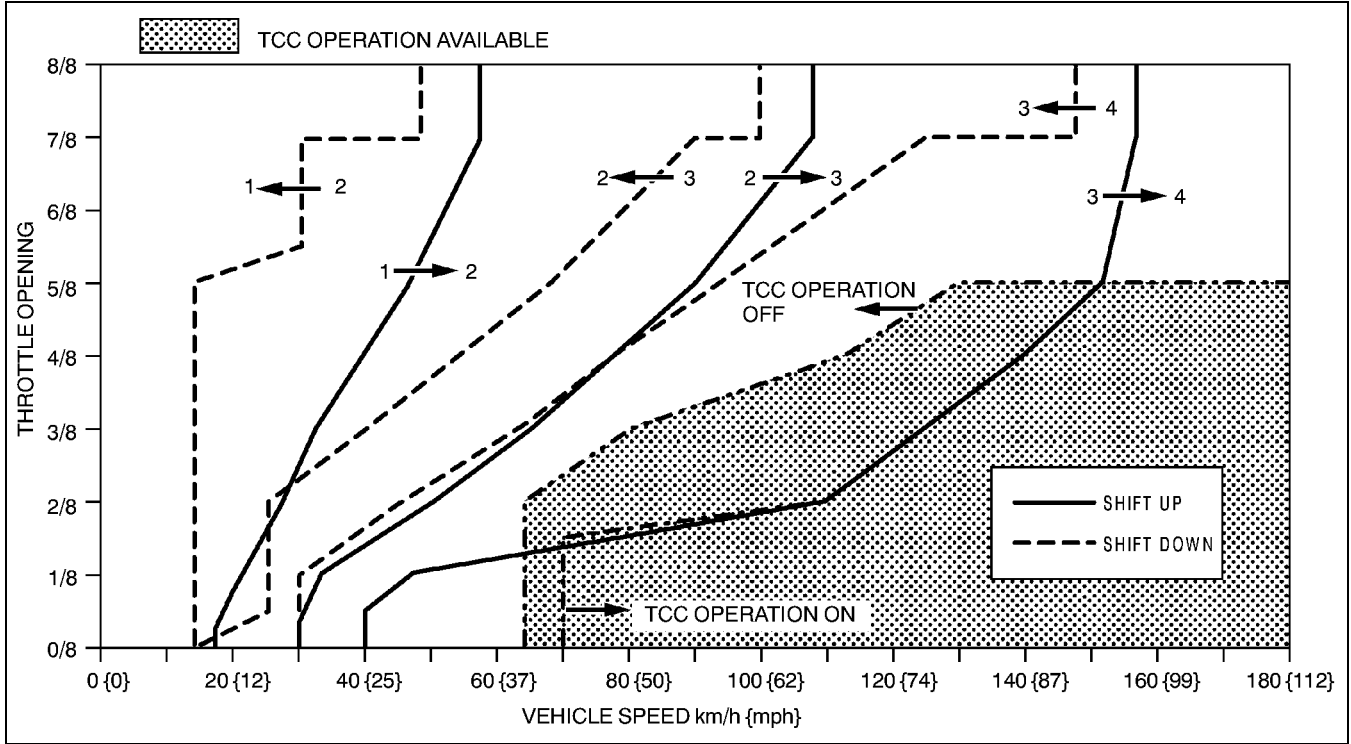

Z3U517W10

05-17

**FS**

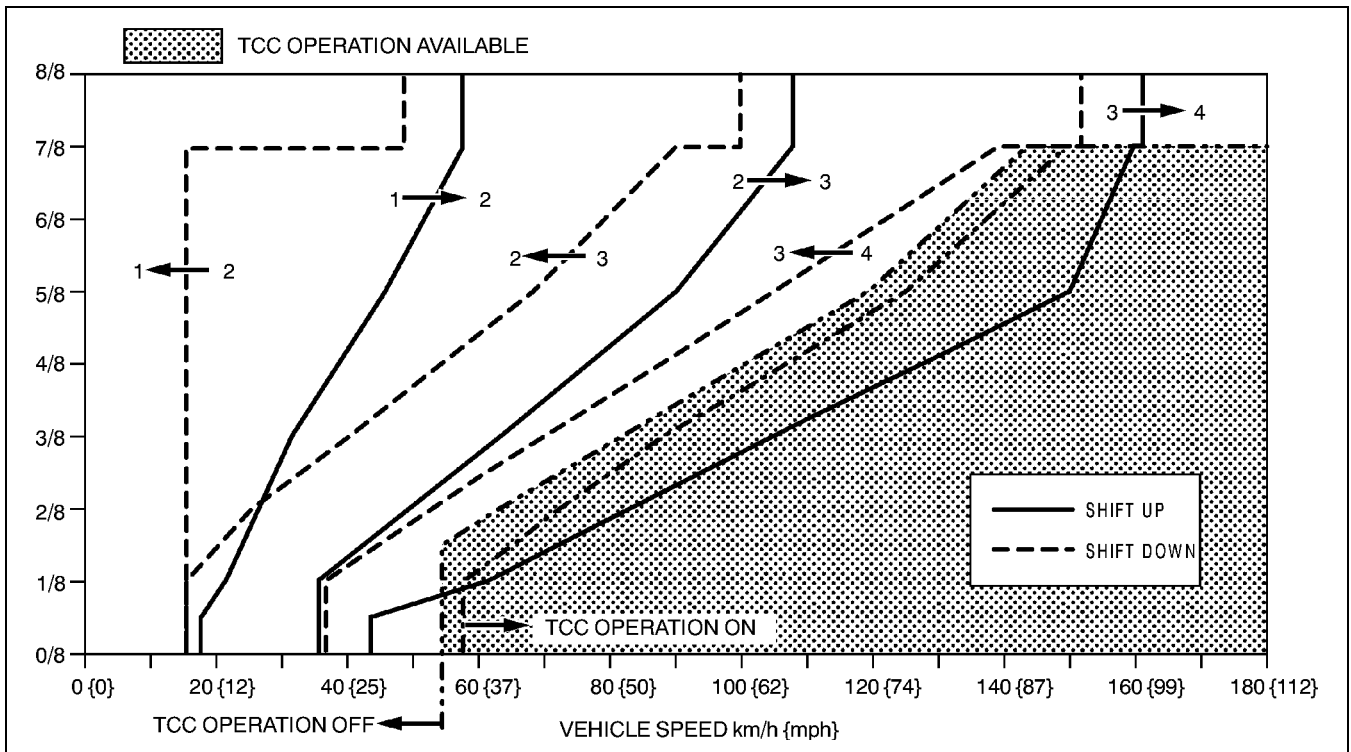

Z3U517W11

# AUTOMATIC TRANSAXLE

**Vehicle speed at shift point table**

Range	Mode	Throttle condition	Shift	Vehicle speed km/h {mph}		Turbine speed (rpm)	
				ZM	FS	ZM	FS
D	Normal	WOT	D <sub>1</sub> →D <sub>2</sub>	56—62 {35—38}	56—62 {35—38}	5,750—6,300	5,750—6,300
			D <sub>2</sub> →D <sub>3</sub>	106—114 {66—70}	106—114 {66—70}	5,750—6,150	5,750—6,150
			D <sub>3</sub> →D <sub>4</sub>	154—164 {96—101}	158—168 {98—104}	5,600—5,900	5,750—6,050
		Half throttle	D <sub>1</sub> →D <sub>2</sub>	35—43 {22—26}	34—42 {22—26}	3,500—4,450	3,400—4,350
			D <sub>2</sub> →D <sub>3</sub>	69—86 {43—53}	68—85 {43—52}	3,750—4,650	3,650—4,650
			D <sub>3</sub> →D <sub>4</sub>	127—150 {79—93}	113—142 {71—88}	4,600—5,450	4,100—5,100
			TCC ON (D <sub>4</sub> )	127—150 {79—93}	113—142 {71—88}	3,350—3,950	3,000—3,700
		CTP	D <sub>4</sub> →D <sub>3</sub>	27—33 {17—20}	33—39 {21—24}	750—850	900—1,000
			D <sub>3</sub> →D <sub>2</sub>	11—17 {7—10}	12—18 {8—11}	400—600	450—650
			D <sub>2</sub> →D <sub>1</sub>	11—17 {7—10}	12—18 {8—11}	600—900	700—950
			D <sub>3</sub> →D <sub>1</sub>	11—17 {7—10}	12—18 {8—11}	400—600	450—650
		Kickdown (WOT)	D <sub>4</sub> →D <sub>3</sub>	143—153 {89—94}	147—157 {92—97}	3,800—4,000	3,900—4,100
	D <sub>3</sub> →D <sub>2</sub>		96—104 {60—64}	96—104 {60—64}	3,500—3,750	3,500—3,750	
	D <sub>2</sub> →D <sub>1</sub>		45—51 {28—31}	45—51 {28—31}	2,450—2,750	2,450—2,750	
	Power	WOT	D <sub>1</sub> →D <sub>2</sub>	56—62 {35—38}	56—62 {35—38}	5,750—6,300	5,750—6,300
			D <sub>2</sub> →D <sub>3</sub>	106—114 {66—70}	106—114 {66—70}	5,750—6,150	5,750—6,150
			D <sub>3</sub> →D <sub>4</sub>	154—164 {96—101}	158—168 {98—104}	5,600—5,900	5,750—6,050
		Half throttle	D <sub>1</sub> →D <sub>2</sub>	35—43 {22—26}	34—42 {22—26}	3,500—4,450	3,400—4,350
			D <sub>2</sub> →D <sub>3</sub>	69—86 {43—53}	68—85 {43—52}	3,750—4,650	3,650—4,650
			D <sub>3</sub> →D <sub>4</sub>	127—150 {79—93}	113—142 {71—88}	4,600—5,450	4,100—5,100
		CTP	D <sub>4</sub> →D <sub>3</sub>	27—33 {17—20}	33—39 {21—24}	750—850	900—1,000
			D <sub>3</sub> →D <sub>2</sub>	11—17 {7—10}	12—18 {8—11}	400—600	450—650
			D <sub>2</sub> →D <sub>1</sub>	11—17 {7—10}	12—18 {8—11}	600—900	700—950
			D <sub>3</sub> →D <sub>1</sub>	11—17 {7—10}	12—18 {8—11}	400—600	450—650
Kickdown (WOT)		D <sub>4</sub> →D <sub>3</sub>	143—153 {89—94}	147—157 {92—97}	3,800—4,000	3,900—4,100	
		D <sub>3</sub> →D <sub>2</sub>	96—104 {60—64}	96—104 {60—64}	3,500—3,750	3,500—3,750	
	D <sub>2</sub> →D <sub>1</sub>	45—51 {28—31}	45—51 {28—31}	2,450—2,750	2,450—2,750		
2	—	—	2 <sub>4</sub> →2 <sub>3</sub>	154—160 {96—99}	158—164 {98—101}	4,050—4,200	4,150—4,300
			2 <sub>3</sub> →2 <sub>2</sub>	99—105 {62—65}	97—103 {61—63}	3,600—3,800	3,550—3,700
1	—	—	1 <sub>4</sub> →1 <sub>3</sub>	154—160 {96—99}	158—164 {98—101}	4,050—4,200	4,150—4,300
			1 <sub>3</sub> →1 <sub>2</sub>	99—105 {62—65}	97—103 {61—63}	3,600—3,800	3,550—3,700
			1 <sub>2</sub> →1 <sub>1</sub>	42—48 {27—29}	42—48 {27—29}	2,300—2,600	2,300—2,600

## D Range Test

1. Perform road test preparation. (See 05-17-14 Road Test Preparation.)
2. Shift the selector lever to D range.
3. Accelerate the vehicle at half and WOT.
4. Verify that 1→2, 2→3, and 3→4 upshifts and downshifts are obtained. The shift points must be as shown in the table below.
  - If not as specified, inspect the PCM and ATX. (See 01-40A-7 PCM INSPECTION [ZM].) (See 01-40B-7 PCM INSPECTION [FS].) (See ATX Workshop Manual.)
5. Drive the vehicle in 4GR, 3GR, and 2GR and verify that kickdown occurs for 4→3, 3→2, 2→1 downshifts, and that the shift points are as shown in the table below.
  - If not as specified, inspect the PCM and ATX. (See 01-40A-7 PCM INSPECTION [ZM].) (See 01-40B-7 PCM INSPECTION [FS].) (See ATX Workshop Manual.)
6. Decelerate the vehicle and verify that engine braking effect is felt in 2GR, 3GR and 4GR.
  - If not as specified, inspect the PCM and ATX. (See 01-40A-7 PCM INSPECTION [ZM].) (See 01-40B-7 PCM INSPECTION [FS].) (See ATX Workshop Manual.)

# AUTOMATIC TRANSAXLE

7. Drive the vehicle and verify that TCC operation is obtained. The operation points must be as shown in the table below.
  - If not as specified, inspect the PCM and ATX. (See 01–40A–7 PCM INSPECTION [ZM].) (See 01–40B–7 PCM INSPECTION [FS].) (See ATX Workshop Manual.)
8. Select O/D OFF mode.
9. Accelerate the vehicle to half throttle and WOT, and verify that 1→2 and 2→3 upshift and downshift are obtained. The shift points must be as shown in the table below.
  - If not as specified, inspect the PCM and ATX. (See 01–40A–7 PCM INSPECTION [ZM].) (See 01–40B–7 PCM INSPECTION [FS].) (See ATX Workshop Manual.)
10. Drive the vehicle in 3GR, 2GR and verify that kickdown occurs for 3→2, 2→1, and that the shift points are as shown in the table below.
  - If not as specified, inspect the PCM and ATX. (See 01–40A–7 PCM INSPECTION [ZM].) (See 01–40B–7 PCM INSPECTION [FS].) (See ATX Workshop Manual.)
11. Decelerate the vehicle and verify that engine braking effect is felt in 2GR and 3GR.
  - If not as specified, inspect the PCM and ATX. (See 01–40A–7 PCM INSPECTION [ZM].) (See 01–40B–7 PCM INSPECTION [FS].) (See ATX Workshop Manual.)

## 2 Range Test

1. Perform road test preparation. (See 05–17–14 Road Test Preparation.)
2. Shift the selector lever to 2 range.
3. Accelerate the vehicle with half throttle and WOT, and verify that 2GR is held.
  - If not as specified, inspect the PCM and ATX. (See 01–40A–7 PCM INSPECTION [ZM].) (See 01–40B–7 PCM INSPECTION [FS].) (See ATX Workshop Manual.)
4. Decelerate the vehicle and verify that engine braking effect is felt.
  - If not as specified, inspect the PCM and ATX. (See 01–40A–7 PCM INSPECTION [ZM].) (See 01–40B–7 PCM INSPECTION [FS].) (See ATX Workshop Manual.)

## 1 Range Test

1. Perform road test preparation. (See 05–17–14 Road Test Preparation.)
2. Shift the selector lever to 1 range.
3. Accelerate the vehicle with half throttle and WOT, and verify that 1GR is held.
  - If not as specified, inspect the PCM and ATX. (See 01–40A–7 PCM INSPECTION [ZM].) (See 01–40B–7 PCM INSPECTION [FS].) (See ATX Workshop Manual.)
4. Decelerate the vehicle and verify that engine braking effect is felt.
  - If not as specified, inspect the PCM and ATX. (See 01–40A–7 PCM INSPECTION [ZM].) (See 01–40B–7 PCM INSPECTION [FS].) (See ATX Workshop Manual.)

## P Position Test

1. Shift into P position on a gentle slope. Release the brake and verify that the vehicle does not roll.
  - If the vehicle rolls, inspect the ATX. (See ATX Workshop Manual.)

## AUTOMATIC TRANSAXLE FLUID (ATF) INSPECTION

A3U051719001W01

### Automatic Transaxle Fluid (ATF) Condition Inspection

1. One way of determining whether the transaxle should be replaced is by noting:
  - If the ATF is muddy or varnished.
  - If the ATF smells strange or unusual.

#### ATF condition

Condition		Possible cause
Clear red	Normal	—
Light red (pink)	Contaminated with water	<ul style="list-style-type: none"> <li>• Broken oil cooler inside of radiator</li> <li>• Poor filler tube installation: Problem could be occurring to parts inside of transaxle by water contamination.</li> <li>• If necessary, replace transaxle.</li> </ul>
Reddish brown	Has burnt smell and metal specks are found	Defect powertrain components inside of transaxle: Specks cause wide range of problems by plugging up oil pipe, control valve body and oil cooler in radiator. <ul style="list-style-type: none"> <li>• When large amount of metal specks are found. Replace transaxle if necessary.</li> <li>• Implement flushing operation as there is a possibility to have specks plugging up oil pipe and/or oil cooler inside of radiator.</li> </ul>
	Has no burnt smell	Normal <ul style="list-style-type: none"> <li>• Discoloration by oxidation.</li> </ul>

# AUTOMATIC TRANSAXLE

## Automatic Transaxle Fluid (ATF) Level Inspection

### Caution

- The ATF amount varies according to ATF temperature. Therefore, when checking the ATF level or replacing the ATF, use a thermometer to measure the temperature then adjust the ATF amount to the specified level according to the specified temperature.

1. Park the vehicle on level ground.
2. Apply the parking brake and position wheel chocks securely to prevent the vehicle from rolling.
3. Adjust the length or thermistor probe to measure the same depth as the oil dipstick and hold the probe with a paper holder.
4. Insert into the filler tube and measure the temperature.
5. Inspect the ATF level before warming up the engine. In this case, use the cool (20 °C {68 °F}) range.
6. Warm up the engine until the ATF reaches (60—70 °C {141—158 °F}).
7. While depressing the brake pedal, shift the selector lever to each range (P—1), pausing momentarily in each range.
8. Shift back to P position.
9. While the engine is idling, verify that the ATF level is in the HOT (65 °C {149 °F}) range. Add ATF to the specification, if necessary.

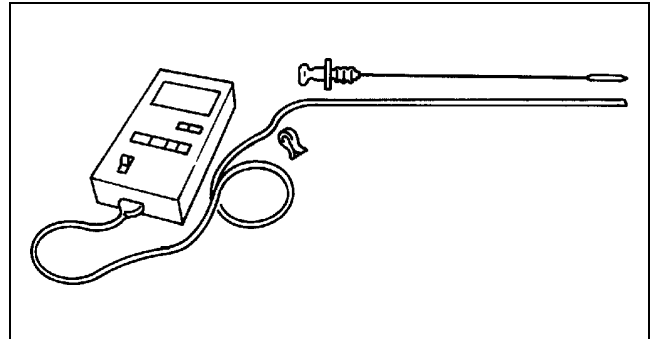

X3U517WA3

### ATF type

M-V or equivalent (e.g. Dexron®III)

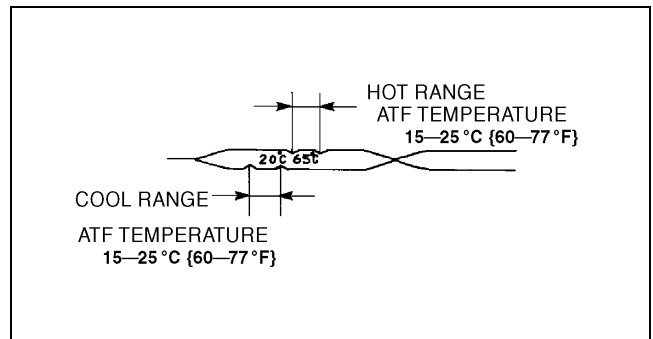

Y3U517WA5

## AUTOMATIC TRANSAXLE FLUID (ATF) REPLACEMENT

A3U051719001W02

### Warning

- When the transaxle and ATF are hot, they can badly burn you. Turn off the engine and wait until they are cool before changing the ATF.

1. Remove the oil dipstick.
2. Remove the drain plug and washer.
3. Drain the ATF into a container.
4. Install a new washer and the drain plug.

### Tightening torque

30—41 N·m {3.0—4.2 kgf·m, 22—30 ft·lbf}

5. Add the specified type of ATF through the oil filler tube until ATF level reaches lower notch of dipstick.

### ATF type

M-V or equivalent (e.g. Dexron®III)

6. That the ATF level is in the HOT (65 °C {149 °F}) range.
7. Add ATF to the specified level if necessary.

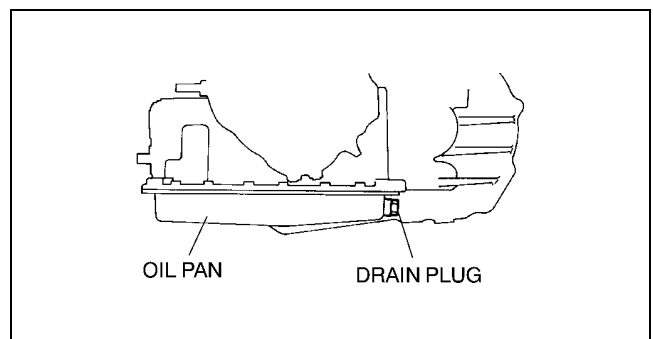

X3U517WA5

# AUTOMATIC TRANSAXLE

## O/D OFF SWITCH INSPECTION

A3U051746040W01

### Inspection of Operation

1. Turn the ignition switch from OFF to ON.
2. Verify that the O/D OFF indicator light is not illuminated. Depress the O/D OFF switch and verify that the O/D OFF indicator light illuminates.
  - If not as specified, inspect the terminal voltage of the O/D OFF switch. (See 05-17-19 Inspection of Voltage.)

### Inspection of Voltage

1. Turn the ignition switch at ON.
2. Measure the voltage at the O/D OFF switch connector.
  - If not as specified, inspect for continuity at the O/D OFF switch. (See 05-17-19 Inspection of Continuity.)

Position	Connector terminal	
	C	D
Normal	B+	0
Depressed	0	0

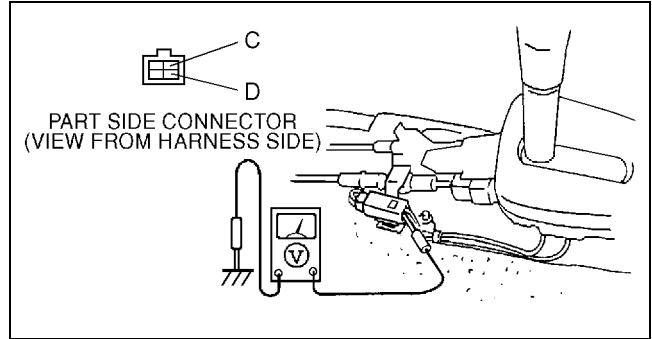

05-17

### Inspection of Continuity

1. Inspect for continuity at the O/D OFF switch.
  - If the switch is okay, inspect the wiring harness. (O/D OFF switch — PCM, O/D OFF switch — Body ground)
  - If not as specified, replace the selector lever knob component. (See 05-18-8 SELECTOR LEVER DISASSEMBLY/ASSEMBLY.)

○—○ : Continuity

Position	Connector Terminal	
	C	D
Normal		
Depressed	○—○	○—○

X3U517WCN

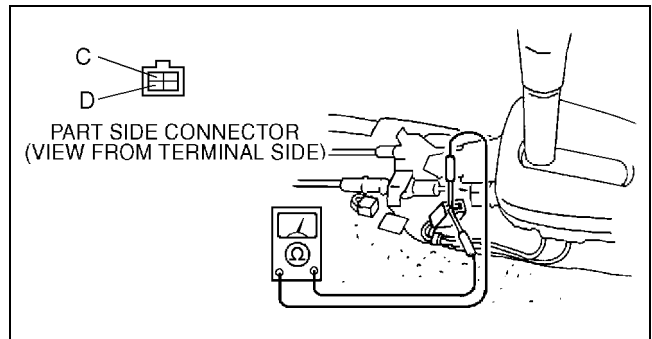

## O/D OFF SWITCH REMOVAL/INSTALLATION

A3U051746040W02

1. Disconnect the negative battery cable.
2. Remove the center console.
3. Remove the selector lever nuts.
4. Disconnect the connector and remove the O/D OFF switch terminals. (See 05-18-8 Connector Disassembly Note.)
5. Remove the selector lever knob component.
6. Install a new selector lever knob component.

### Tightening torque

2.0—2.9 N·m {20—30 kgf·cm, 18—26 in·lbf}

7. Install the selector lever nuts.

### Tightening torque

16—22 N·m {1.6—2.3 kgf·m, 12—16 ft·lbf}

8. Install the O/D OFF switch terminals and connect the connector.
9. Install the center console.
10. Connect the negative battery cable.

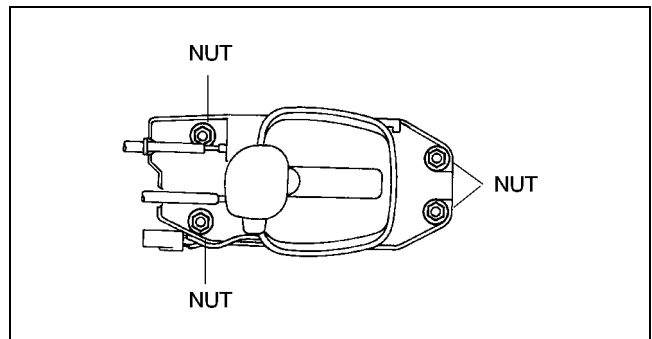

Z3U517W04

# AUTOMATIC TRANSAXLE

## TRANSAXLE RANGE (TR) SWITCH INSPECTION

A3U051719440W01

### Inspection of Operation

1. Verify that the starter operates only with the IG SW at the START position and the selector lever in P and N positions.
  - If not as specified, inspect for continuity at the TR switch. (See 05-17-20 Inspection of Continuity.)
2. Verify that the back-up lights illuminate when shifted to R position with the ignition switch at the ON position.
  - If not as specified, inspect for continuity at the TR switch. (See 05-17-20 Inspection of Continuity.)

### Inspection of Continuity

1. Inspect for continuity at the TR switch.

○—○ : Continuity

Position	Connector terminal								
	A	B	C	D	E	F	G	H	I
P	○	○						○	○
R			○						○
N		○						○	
D				○					○
2						○			○
1					○				○

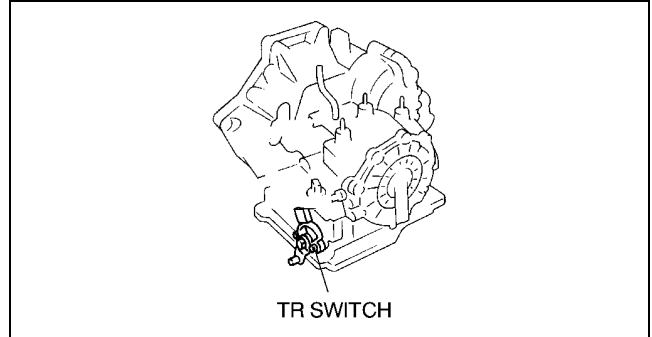

X3U517WA9

Z3U517W13

- If not as specified, replace or adjust the TR switch. (See 05-17-20 TRANSAXLE RANGE (TR) SWITCH REMOVAL/INSTALLATION.) (See 05-17-23 TRANSAXLE RANGE (TR) SWITCH ADJUSTMENT.)

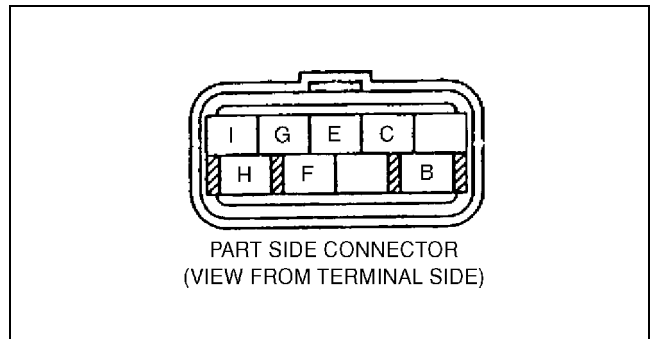

Z3U517W14

## TRANSAXLE RANGE (TR) SWITCH REMOVAL/INSTALLATION

A3U051719440W02

1. Disconnect the negative battery cable.
2. Remove the fresh-air duct and air cleaner component. (See 01-13A-5 INTAKE-AIR SYSTEM REMOVAL/INSTALLATION [ZM].) (See 01-13B-6 INTAKE-AIR SYSTEM REMOVAL/INSTALLATION [FS].)
3. Remove the splash shield.
4. Disconnect the TR switch connector.

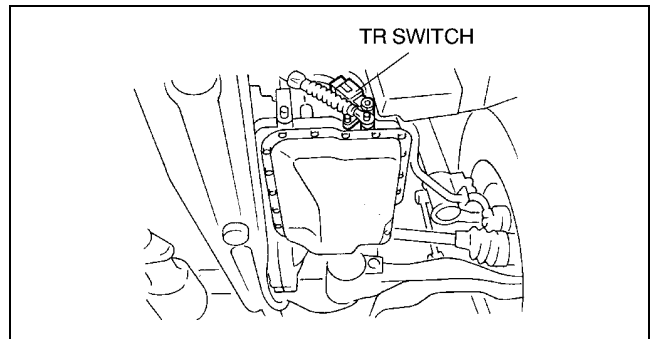

X3U517WAB

# AUTOMATIC TRANSAXLE

- Remove the clip and disconnect the selector cable.

### Caution

- Do not use an impact wrench. Hold the manual shaft lever when removing the manual shaft nut, or the transaxle may be damaged.

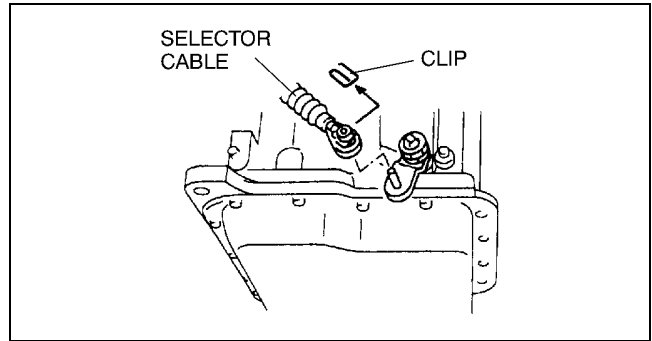

X3U517WAC

- Set the adjustable wrench as shown to hold the manual shaft lever.
- Remove the manual shaft nut and washer.

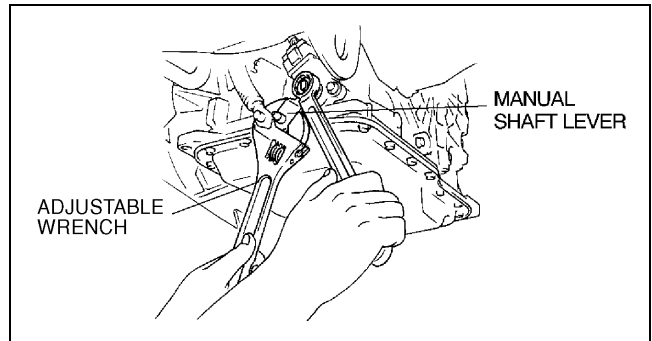

Y3U517WAM

- Remove the manual shaft lever.
- Remove the TR switch.

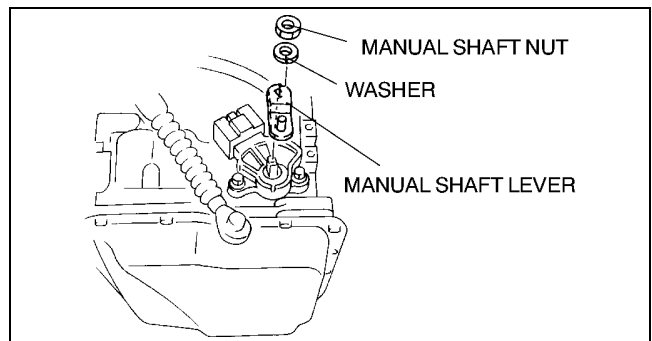

X3U517WAD

- Rotate the manual shaft to the converter housing side fully, then return 2 notches to set the N position.

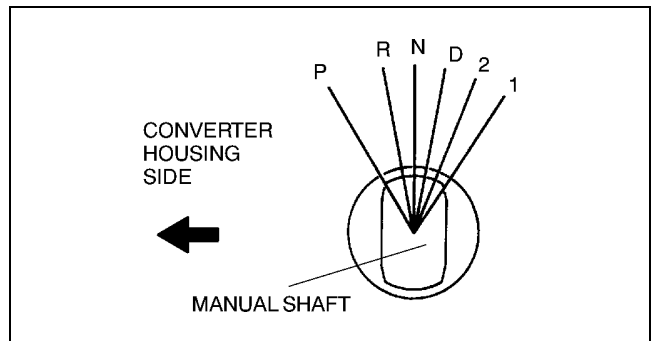

X3U517WAE

- Align the protrusion and mark as shown.

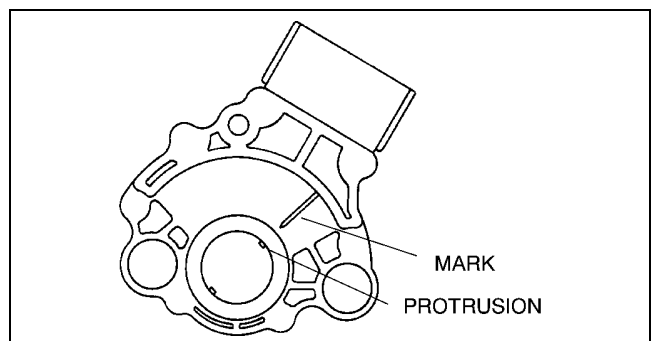

X3U517WCW



## AUTOMATIC TRANSAXLE

12. Install the TR switch while aligning the protrusion and groove as shown.

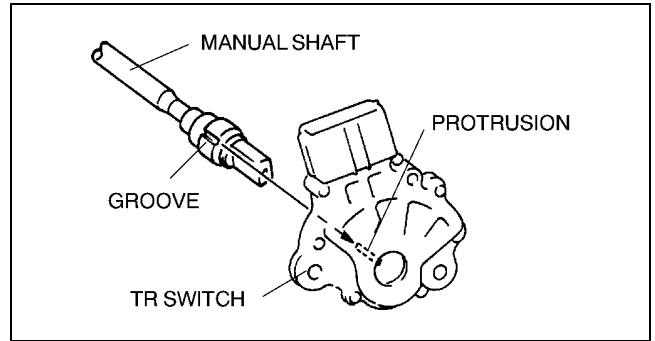

X3U517WCX

13. Turn the TR switch so that the neutral hole is in line with the flat, straight surfaces on either side of the manual shaft.  
14. Hand-tighten the TR switch bolts.  
15. Perform the TR switch adjustment. (See 05-17-23 TRANSAXLE RANGE (TR) SWITCH ADJUSTMENT.)  
16. Install the manual shaft lever and washer.

### Caution

- Do not use an impact wrench. Hold the manual shaft lever when tightening the manual shaft nut, or the transaxle may be damaged.

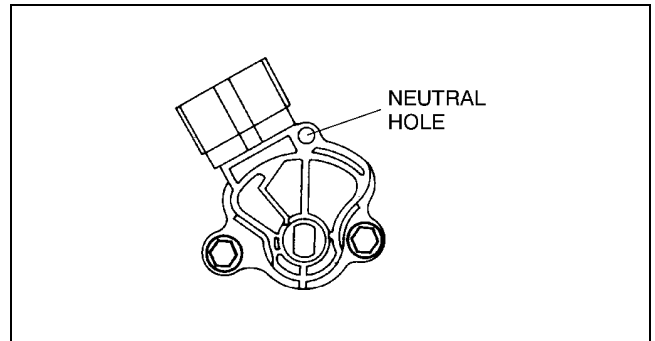

X3U517WAF

17. Set the adjustable wrench as shown to hold the manual shaft lever.  
18. Tighten the manual shaft nut using a torque wrench.

### Tightening torque

**32—46 N·m {3.2—4.7 kgf·m, 24—33 ft·lbf}**

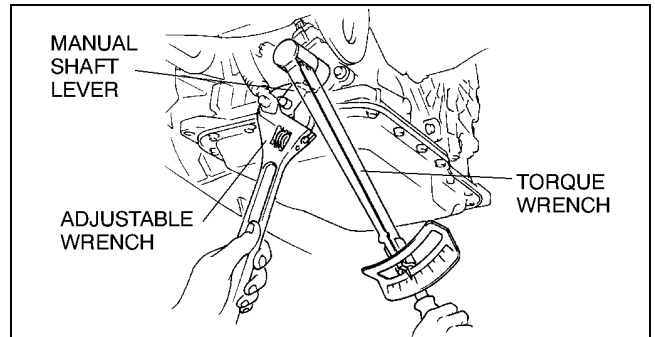

X3U517WAJ

19. Install the clip as shown in the figure.

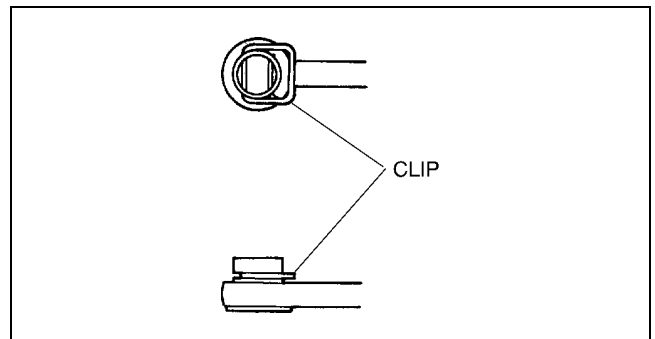

X3U517WCZ

## AUTOMATIC TRANSAXLE

20. Verify that the selector lever range position and TR switch are aligned, then connect the selector cable.
21. Inspect for continuity at the TR switch. (See 05-17-20 Inspection of Continuity.)
22. Connect the TR switch connector.
23. Install the splash shield.
24. Install the air cleaner component and fresh-air duct. (See 01-13A-5 INTAKE-AIR SYSTEM REMOVAL/INSTALLATION [ZM].) (See 01-13B-6 INTAKE-AIR SYSTEM REMOVAL/INSTALLATION [FS].)
25. Connect the negative battery cable.
26. Inspect operation of the TR switch. (See 05-17-20 Inspection of Operation.)

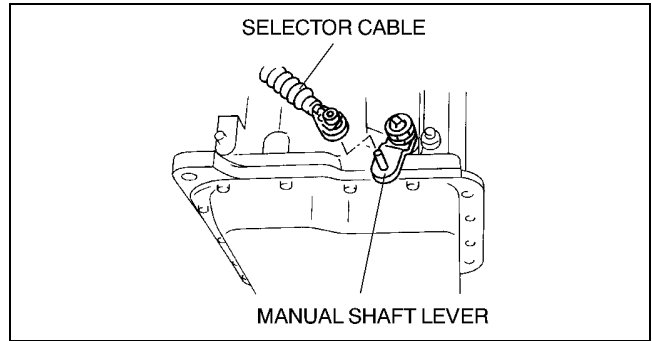

X3U517WAK

### TRANSAXLE RANGE (TR) SWITCH ADJUSTMENT

A3U051719440W03

05-17

1. Disconnect the negative battery cable.
2. Remove the fresh-air duct and air cleaner component. (See 01-13A-5 INTAKE-AIR SYSTEM REMOVAL/INSTALLATION [ZM].) (See 01-13B-6 INTAKE-AIR SYSTEM REMOVAL/INSTALLATION [FS].)
3. Remove the splash shield.
4. Remove the clip and disconnect the selector cable.

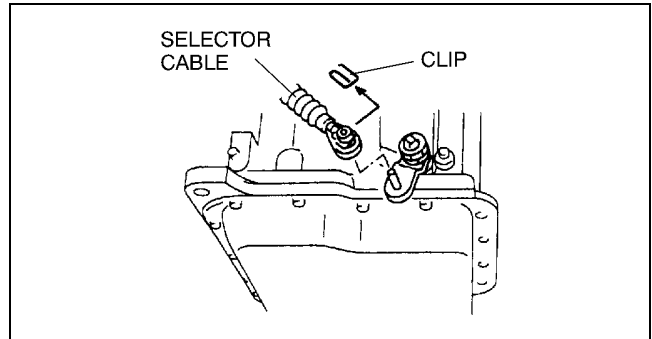

X3U517WD0

5. Rotate the manual shaft to the converter housing side fully, then return 2 notches to set the N position.

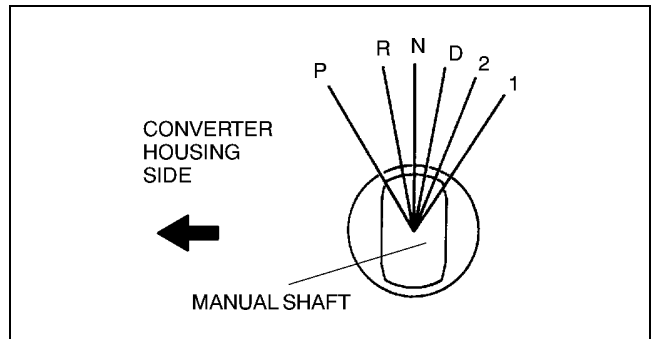

X3U517WD3

6. Disconnect the TR switch connector.

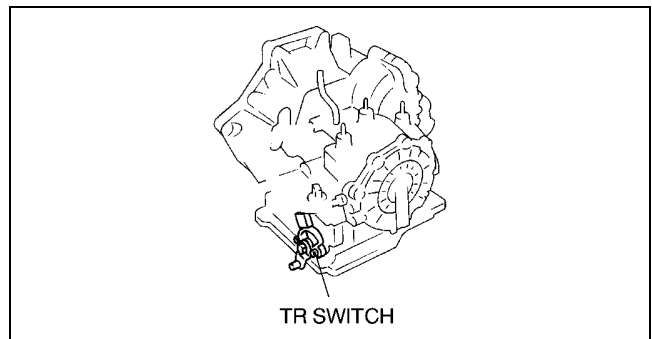

X3U517WAL

## AUTOMATIC TRANSAXLE

7. Loosen the TR switch mounting bolts.

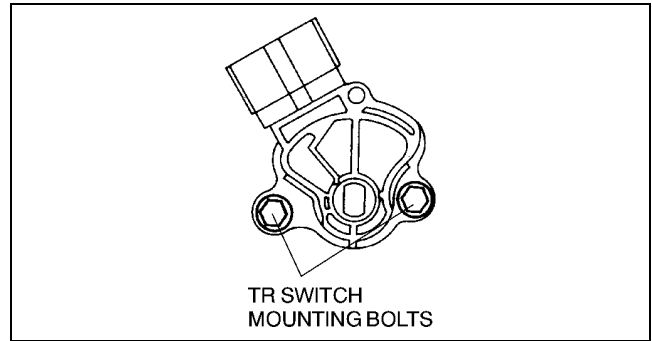

8. Connect an ohmmeter between terminals B and H.
9. Adjust the switch to the point where there is continuity between the terminals.
10. Tighten the TR switch mounting bolts.

### Tightening torque

7.9—10.7 N·m {80—110 kgf·cm, 69.5—95.4 in·lbf}

11. Verify that the selector lever range position and TR switch are aligned.
12. Connect the TR switch connector.
13. Install the clip as shown in the figure.

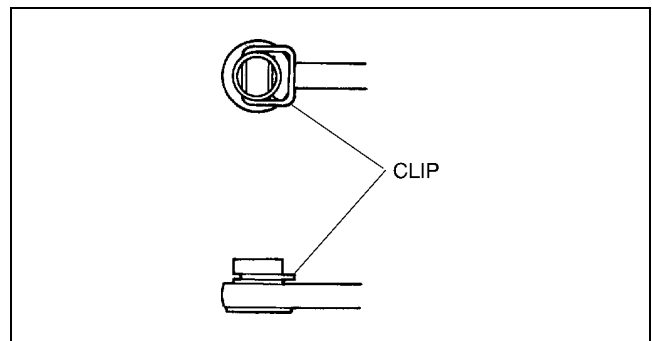
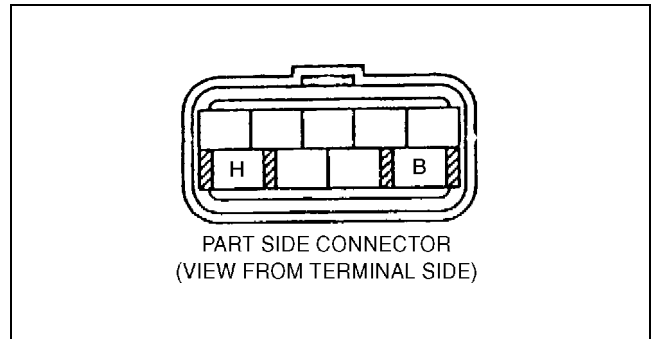

14. Connect the selector cable.
15. Install the splash shield.
16. Install the air cleaner component and fresh-air duct. (See 01-13A-5 INTAKE-AIR SYSTEM REMOVAL/INSTALLATION [ZM].) (See 01-13B-6 INTAKE-AIR SYSTEM REMOVAL/INSTALLATION [FS].)
17. Connect the negative battery cable.

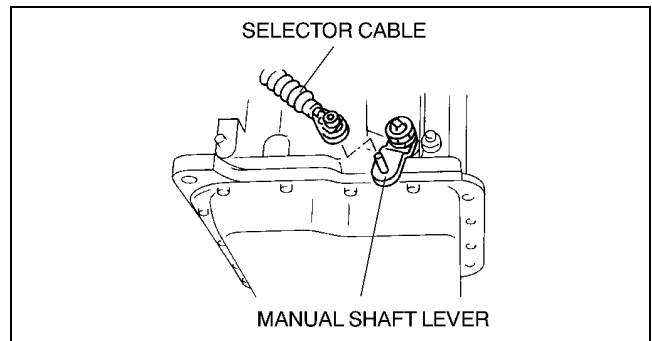

# AUTOMATIC TRANSAXLE

## TRANSAXLE FLUID TEMPERATURE (TFT) SENSOR INSPECTION

A3U051719010W01

1. Measure the resistance between the terminals E and H.
  - If it is out of specifications, replace the TFT sensor. (See 05-17-25 TRANSAXLE FLUID TEMPERATURE (TFT) SENSOR REMOVAL/INSTALLATION.)

ATF temperature (°C {°F})	Resistance (kilohm}
-20 {-4}	236—324
0 {32}	84.3—110
20 {68}	33.5—42.0
40 {104}	14.7—17.9
60 {140}	7.08—8.17
80 {176}	3.61—4.15
100 {212}	1.96—2.24
120 {248}	1.13—1.28
130 {266}	0.87—0.98

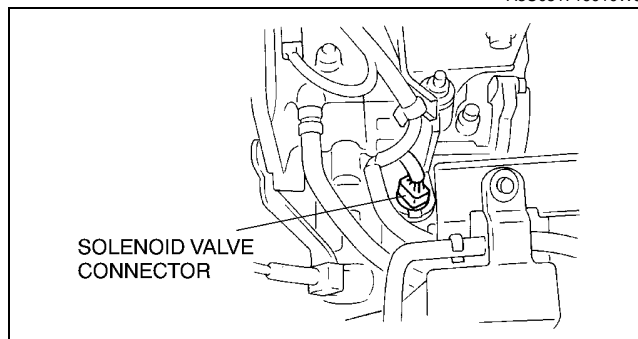

X3U517WAP

05-17

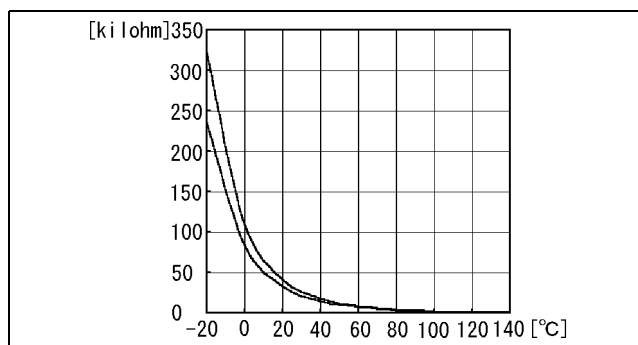

Z3U517W12

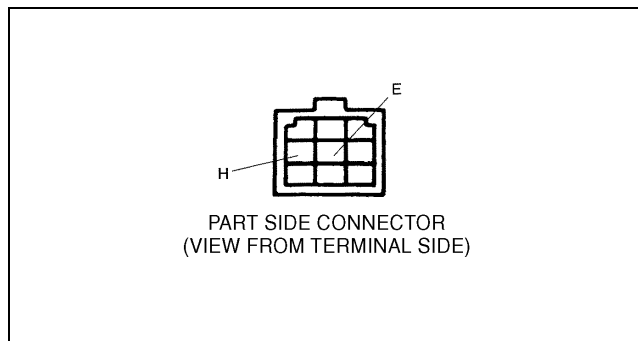

Y3U517WAA

## TRANSAXLE FLUID TEMPERATURE (TFT) SENSOR REMOVAL/INSTALLATION

A3U051719010W02

### Warning

- When the transaxle and ATF are hot, they can badly burn. Turn off the engine and wait until they are cool before performing this procedure.

1. Remove the oil pan. (See 05-17-36 On-vehicle Removal.)
2. Disconnect the TFT sensor connector.

## AUTOMATIC TRANSAXLE

3. Remove the TFT sensor.
4. Install a new TFT sensor.
5. Connect the TFT sensor connector.
6. Install the oil pan. (See 05-17-38 On-vehicle Installation.)
7. Carry out the mechanical system test. (See 05-17-11 MECHANICAL SYSTEM TEST.)

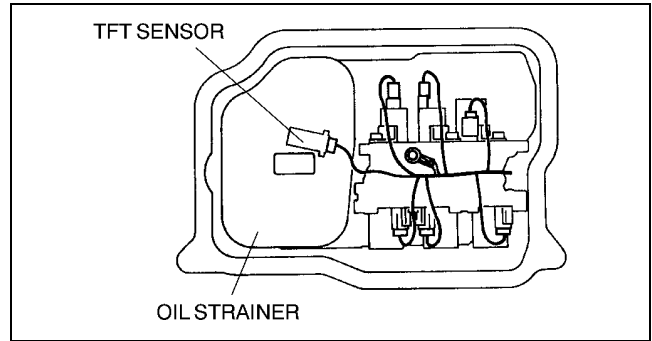

X3U517WAR

### INPUT/TURBINE SPEED SENSOR INSPECTION

#### Resistance Inspection

1. Measure the resistance between the terminals of the input/turbine speed sensor.

#### Resistance

**250—600 ohms (ATF temperature: -40—160 °C {-40—320 °F})**

- If not as specified, replace the input/turbine speed sensor. (See 05-17-26 INPUT/TURBINE SPEED SENSOR REMOVAL/INSTALLATION.)

A3U051721550W01

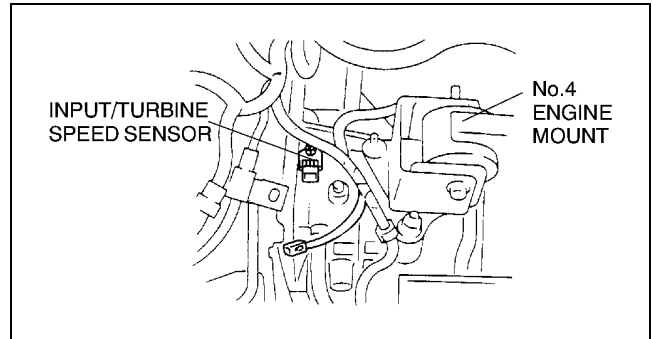

X3U517WAS

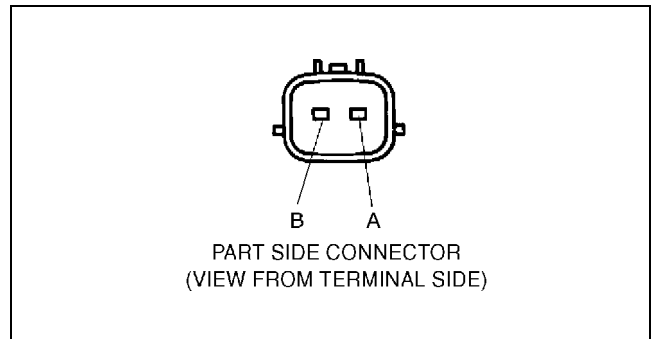

Z3U517W16

### INPUT/TURBINE SPEED SENSOR REMOVAL/INSTALLATION

A3U051721550W02

1. Disconnect the negative battery cable.
2. Remove the air cleaner component. (See 01-13A-5 INTAKE-AIR SYSTEM REMOVAL/INSTALLATION [ZM].) (See 01-13B-6 INTAKE-AIR SYSTEM REMOVAL/INSTALLATION [FS].)

3. Disconnect the input/turbine speed sensor connector.
4. Remove the input/turbine speed sensor.
5. Apply ATF to a new O-ring and install it on a new input/turbine speed sensor.
6. Install the input/turbine speed sensor.

#### Tightening torque

**7.9—10.7 N·m {80—110 kgf·cm, 69.5—95.4 in·lbf}**

7. Connect the input/turbine speed sensor connector.
8. Install the air cleaner component. (See 01-13A-5 INTAKE-AIR SYSTEM REMOVAL/INSTALLATION [ZM].) (See 01-13B-6 INTAKE-AIR SYSTEM REMOVAL/INSTALLATION [FS].)
9. Connect the negative battery cable.

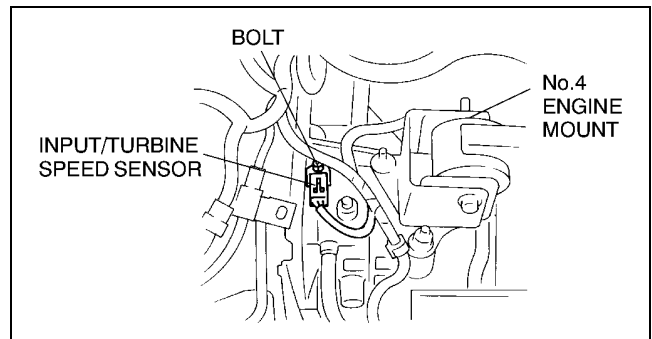

X3U517WAU

# AUTOMATIC TRANSAXLE

## VEHICLE SPEEDOMETER SENSOR (VSS) INSPECTION [ATX]

A3U051717401W01

### Visual Inspection

1. Remove the VSS. (See 05-17-28 VEHICLE SPEEDOMETER SENSOR (VSS) REMOVAL/INSTALLATION [ATX].)
2. Make sure that the sensor is free of any metallic shavings or particles.
  - If any are found on the sensor, clean them off.
3. Install the VSS. (See 05-17-28 VEHICLE SPEEDOMETER SENSOR (VSS) REMOVAL/INSTALLATION [ATX].)

### Wave profile Inspection

1. Remove the PCM. (See 01-40A-7 PCM REMOVAL/INSTALLATION [ZM].) (See 01-40B-7 PCM REMOVAL/INSTALLATION [FS].)
2. Connect WDS or equivalent to DLC-2 connector.
3. Connect the **SST** (104 Pin Breakout Box) to the PCM as shown.
4. Connect oscilloscope test leads to the following PCM connector terminals.
  - (+) lead: PCM terminal 58
  - (-) lead: PCM terminal 103
5. Start the engine.
6. Monitor VSS PID.

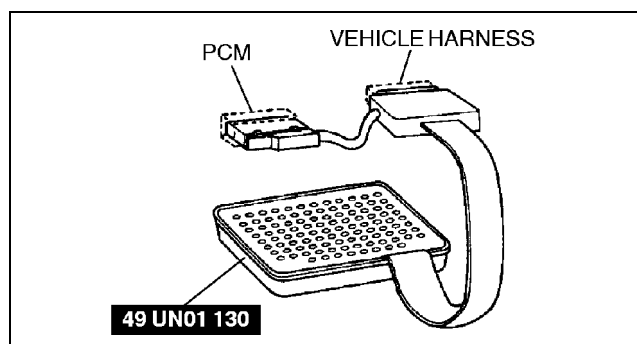

A3U0517W001

05-17

7. Inspect wave profile.
  - PCM terminal: 58 (+)-103(-)
  - Oscilloscope setting: 1 V/DIV(Y), 2.5 ms/DIV(X), DC range
  - Vehicle condition: drive the vehicle with 32 km/h{20 mph}
    - If wave profile or voltage are out of specifications, carry out the “Open Circuit Inspection” or “Short Circuit Inspection”

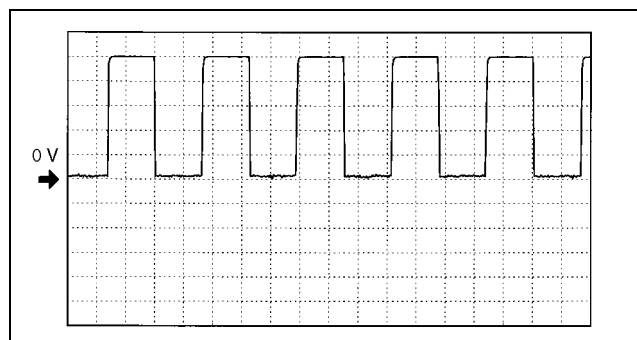

Z3U0140W013

### Power Supply Voltage Inspection

1. Disconnect the VSS connector.
2. Turn the ignition switch to ON.
3. Measure voltage at VSS connector terminal B (wiring harness side).

#### Specification

4.5—5.5 V

- If voltage is okay, go to “See 05-17-27 Open Circuit Inspection” and “Short Circuit Inspection”.
- If voltage is wrong, repair wiring harness between VSS and PCM.

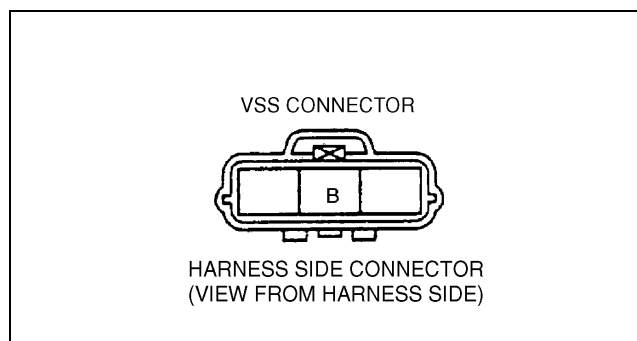

Y3U517WAE

### Open Circuit Inspection

1. Inspect the following circuit for open.
  - Power circuit (VSS connector terminal A to main relay terminal D)
  - Ground circuit (VSS connector terminal C to GND)
  - If an open circuit or short circuit is found, repair the malfunctioning wiring harness.
  - If there are no open or short circuits, perform the sensor rotor inspection. (See 05-17-28 Sensor Rotor Inspection.)

# AUTOMATIC TRANSAXLE

## Short Circuit Inspection

1. Inspect the following circuit for short.
  - Power circuit (VSS connector terminal A to main relay terminal D)
  - If an open circuit or short circuit is found, repair the malfunctioning wiring harness.
  - If there are no open or short circuits, perform the sensor rotor inspection. (See 05-17-28 Sensor Rotor Inspection.)

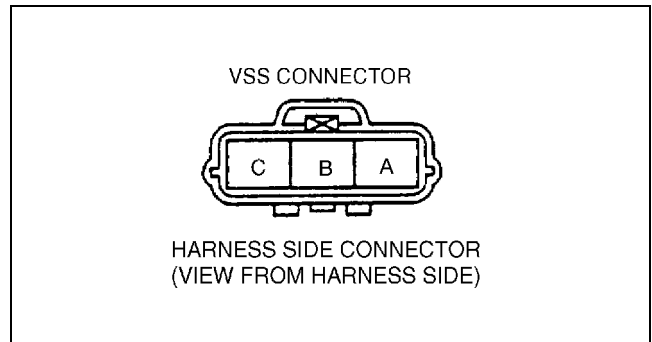

Z3U517W17

## Sensor Rotor Inspection

1. Remove the VSS. (See 05-17-28 VEHICLE SPEEDOMETER SENSOR (VSS) REMOVAL/INSTALLATION [ATX].)
2. Shift the selector lever to N position.
3. Inspect sensor rotor surface via VSS installation hole while rotating the front tire manually.
  - (1) Is sensor rotor free of damage and cracks?
  - (2) Is sensor rotor free of any metallic shavings or particles?
    - If sensor rotor is okay, replace VSS.
    - If there is a problem, clean or replace the sensor rotor.

## VEHICLE SPEEDOMETER SENSOR (VSS) REMOVAL/INSTALLATION [ATX]

A3U051717401W02

1. Disconnect the negative battery cable.
2. Disconnect the VSS connector.
3. Remove the VSS.
4. Apply ATF to a new O-ring and install it on a new VSS.
5. Install the VSS.

### Tightening torque

**7.9—10.7 N·m {80—110 kgf·cm, 69.5—95.4 in·lbf}**

6. Connect the VSS connector.
7. Connect the negative battery cable.

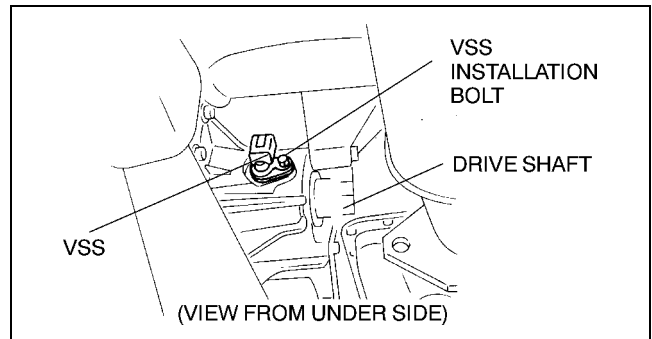

X3U517WAZ

## SOLENOID VALVES INSPECTION

A3U051721280W01

### Inspection of Resistance (On-vehicle)

1. Measure the resistances between the following terminals.
  - If any resistances are out of specifications, inspect the ground, then perform the operation and the part inspection.

ATF temperature: **-40—150 °C {-40—302 °F}**

Terminal	Solenoid valve	Resistance (ohm)
A-GND	Shift solenoid A	1.0—4.2
B-GND	Shift solenoid D	10.9—26.2
C-GND	Shift solenoid B	1.0—4.2
D-I	Pressure control solenoid	2.4—7.3
F-GND	Shift solenoid E	10.9—26.2
G-GND	Shift solenoid C	1.0—4.2

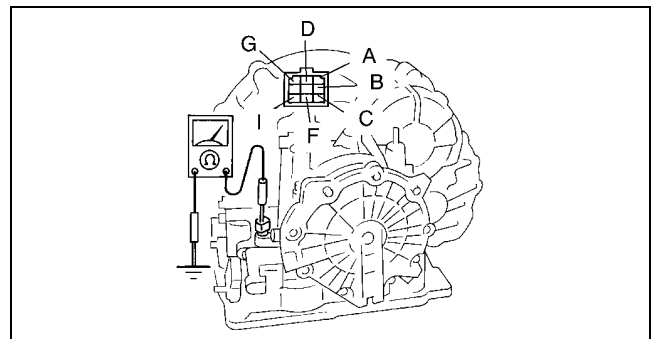

X3U517WB2

# AUTOMATIC TRANSAXLE

## Inspection of Operation

### Note

- When inspecting the pressure control solenoid, connect the GND connection to the GND terminal (I terminal) of the pressure control solenoid inside the solenoid valve connector.
- Do not apply voltage for more than **3 seconds**.

1. Apply B+ to terminal A, B, C, F, or G and battery negative voltage to GND, and verify that a click sound is heard from each solenoid.
  - If the click sound is not heard from each solenoid, replace solenoids.
2. Apply B+ to terminal D and battery negative voltage to terminal I, and verify that a click sound is heard from solenoid.
  - If the "click" is not heard, replace the solenoid valve. (See 05-17-30 SOLENOID VALVES REMOVAL/INSTALLATION.)

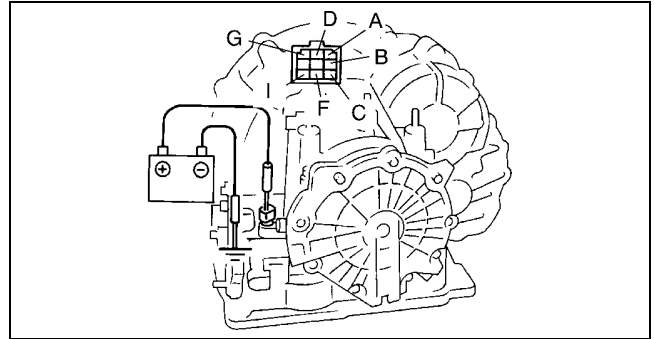

05-17

## Resistance Inspection (Off-vehicle)

1. Measure the resistance of each solenoid valve individually.
  - If not as specified, replace the solenoid valve.

### Pressure control solenoid

Resistance: 2.4—7.3 ohms

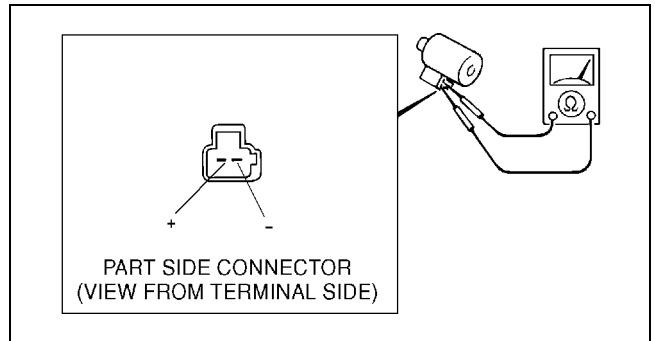

### Shift solenoid A, B, C

Resistance: 1.0—4.2 ohms

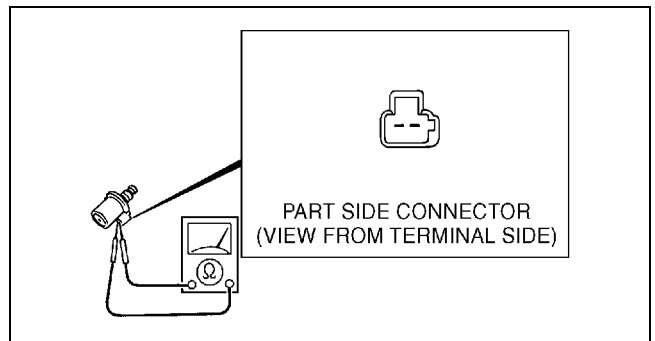



# AUTOMATIC TRANSAXLE

## Shift solenoid D, E

Resistance: 10.9—26.2 ohms

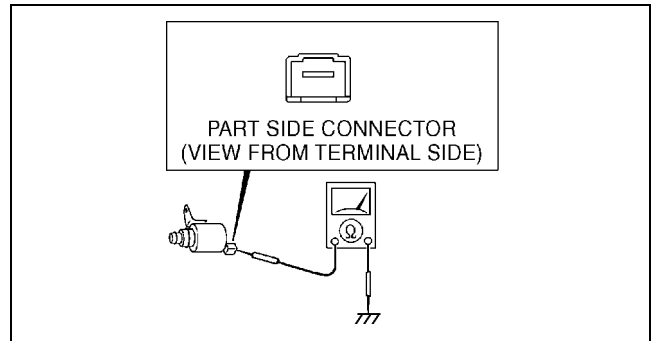

Z3U517W07

## SOLENOID VALVES REMOVAL/INSTALLATION

A3U051721280W02

1. Remove the control valve body. (See 05-17-36 On-vehicle Removal.)
2. Remove the solenoid valve(s).
3. Apply ATF to a new O-ring and install it on the solenoid valve.
4. Install the solenoid valve in the control valve body.

### Tightening torque

7.9—10.7 N·m {80—110 kgf·cm, 69.5—95.4 in·lbf}

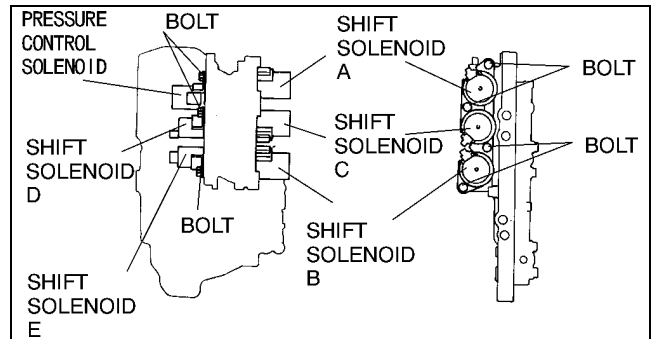

X3U517WB7

5. Install the control valve body. (See 05-17-38 On-vehicle Installation.)
6. Add in ATF and, with the engine idling, inspect the ATF level and inspect for leakage. (See 05-17-18 AUTOMATIC TRANSAXLE FLUID (ATF) REPLACEMENT.) (See 05-17-18 Automatic Transaxle Fluid (ATF) Level Inspection.)
7. Carry out the mechanical system test. (See 05-17-11 MECHANICAL SYSTEM TEST.)
8. Carry out the road test. (See 05-17-14 ROAD TEST.)

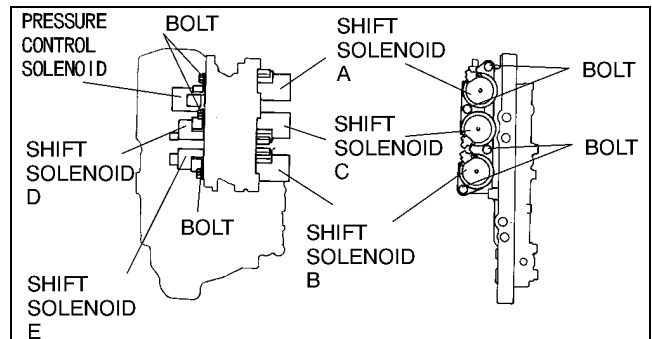

X3U517WB8

## O/D OFF INDICATOR LIGHT INSPECTION

A3U051755480W01

### Inspection of Operation

1. Turn the IG SW from OFF to ON.

### Note

- The O/D OFF indicator light flashes when any malfunction exists in the EC-AT system components.
2. Verify that the O/D OFF indicator light is not illuminating.
  3. Depress the switch and verify that the O/D OFF indicator light illuminates.
    - If the O/D OFF switch does not function, inspect the O/D OFF switch, and then inspect the terminal voltage of the O/D OFF indicator light.

## PCM INSPECTION

A3U051718880W01

1. Inspect the PCM. (See 01-40A-7 PCM INSPECTION [ZM].) (See 01-40B-7 PCM INSPECTION [FS].)

## PCM REMOVAL/INSTALLATION

A3U051718880W02

1. Remove and install the PCM. (See 01-40A-7 PCM REMOVAL/INSTALLATION [ZM].) (See 01-40B-7 PCM REMOVAL/INSTALLATION [FS].)

# AUTOMATIC TRANSAXLE

## AUTOMATIC TRANSAXLE (ATX) REMOVAL/INSTALLATION

A3U051701030W07

1. Drain the ATF. (See 05-17-18 AUTOMATIC TRANSAXLE FLUID (ATF) REPLACEMENT.)
2. Remove the tires and splash shield.
3. Remove the battery and battery carrier.
4. Remove the fresh-air duct and air cleaner component. (See 01-13A-5 INTAKE-AIR SYSTEM REMOVAL/INSTALLATION [ZM].) (See 01-13B-6 INTAKE-AIR SYSTEM REMOVAL/INSTALLATION [FS].)
5. Remove the EGR pipe, front pipe and TWC. (See 01-15-1 EXHAUST SYSTEM REMOVAL/INSTALLATION.)

### Warning

- **Improperly jacking a transaxle is dangerous. It can slip off the jack and may cause serious injury.**

6. Remove in the order indicated in the table.
7. Install in the reverse order of removal.
8. Add ATF to the specified level. (See 05-17-18 AUTOMATIC TRANSAXLE FLUID (ATF) REPLACEMENT.)
9. Carry out the mechanical system test. (See 05-17-11 MECHANICAL SYSTEM TEST.)

Service item	Test item		
	Line pressure test	Stall test	Time lag test
ATX replacement	×		
ATX overhaul	×	×	×
Torque converter replacement	×	×	
Oil pump replacement	×		
Clutch system replacement	×		

× : Test to be performed after the service work

10. Carry out the road test. (See 05-17-14 ROAD TEST.)

05-17

# AUTOMATIC TRANSAXLE

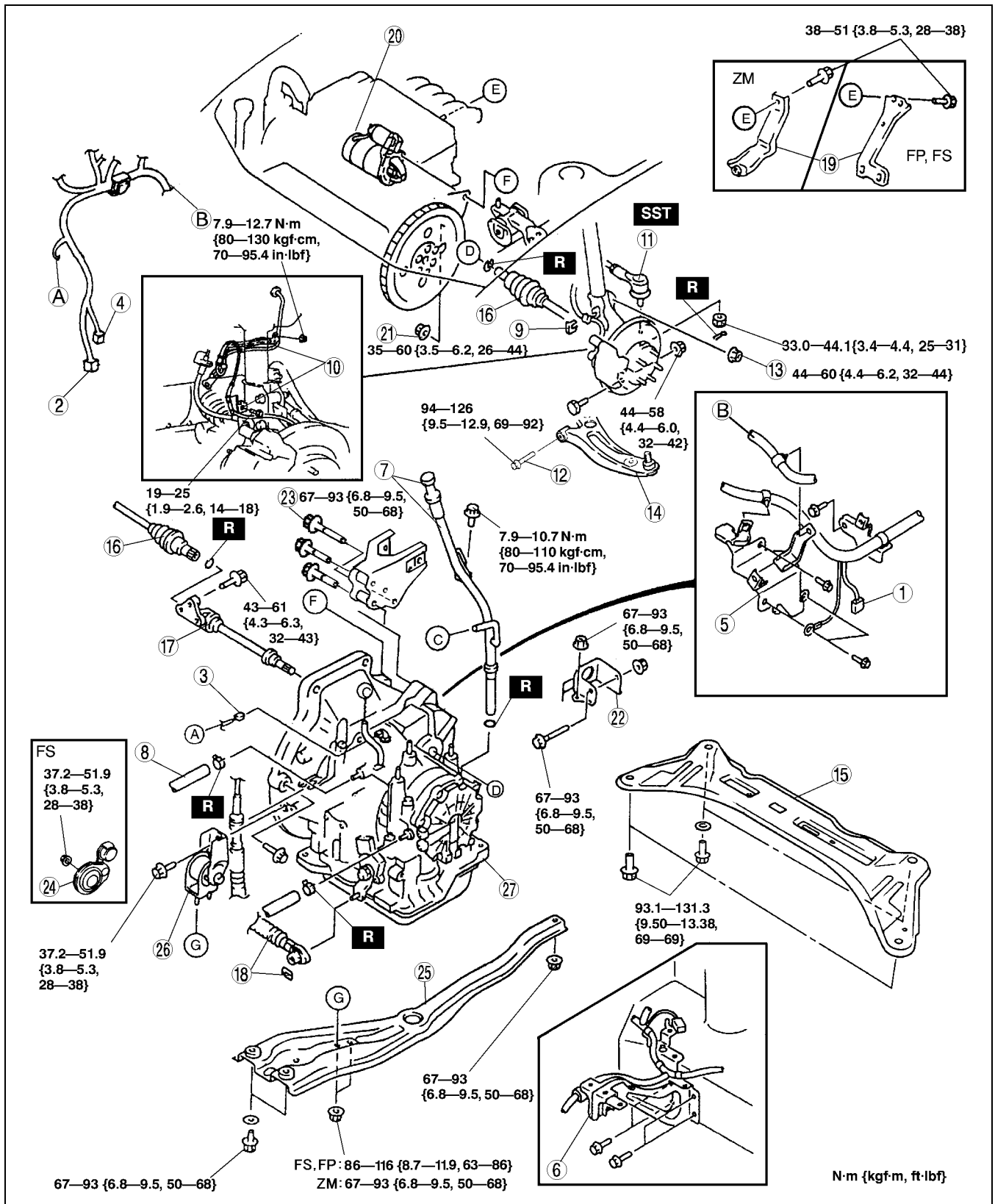

A3U0517W005

1	Vehicle speedometer sensor connector
2	TR switch connector
3	Input/turbine speed sensor connector
4	Transaxle connector
5	Harness bracket
6	Battery tray bracket

7	Oil dipstick and filler tube
8	Oil hose
9	Brake hose clip
10	ABS wheel speed sensor bracket
11	Tie rod end (See 06–12–9 STEERING GEAR AND LINKAGE REMOVAL/INSTALLATION.)

## AUTOMATIC TRANSAXLE

12	Bolt
13	Stabilizer control link nut
14	Lower arm (See 05-17-33 Lower Arm Removal Note.)
15	Transverse member (See 02-13-9 TRANSVERSE MEMBER (ZM (ATX), FS) REMOVAL/INSTALLATION.)
16	Drive shaft (See 03-13-9 DRIVE SHAFT REMOVAL/INSTALLATION.)
17	Joint shaft (See 03-13-3 JOINT SHAFT REMOVAL/INSTALLATION.)
18	Selector cable
19	Intake manifold stay
20	Starter
21	Torque converter installation nuts (See 05-17-34 Torque Converter Installation Nuts Removal Note.)

22	No.4 engine mount (See 05-17-34 No.4 Engine Mount Removal Note.) (See 05-17-35 No.2 Engine Mount, Engine Mounting Member, No.4 Engine Mount Installation Note.)
23	No.1 engine mount bolts
24	Roll damper (FS)
25	Engine mounting member (See 05-17-35 No.2 Engine Mount, Engine Mounting Member, No.4 Engine Mount Installation Note.)
26	No.2 engine mount (See 05-17-35 No.2 Engine Mount, Engine Mounting Member, No.4 Engine Mount Installation Note.)
27	Transaxle (See 05-17-34 Transaxle Removal Note.) (See 05-17-35 Transaxle Installation Note.)

05-17

### Lower Arm Removal Note

1. Remove the clinch bolt from the lower arm ball joint.

#### Caution

- Wrap a rag around the ball joint dust seal to protect it from damage.

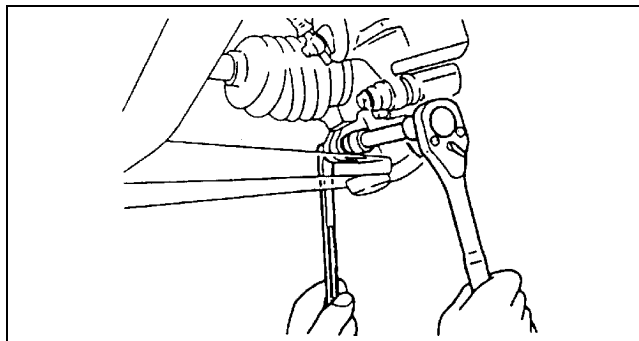

Y3E5614W005

2. Pry the lower arm out of the knuckle.

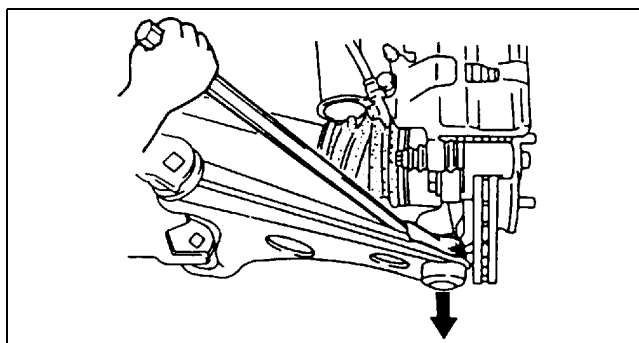

Y3E5614W006

# AUTOMATIC TRANSAXLE

## Torque Converter Installation Nuts Removal Note

1. Remove the seal rubber from the end plate.

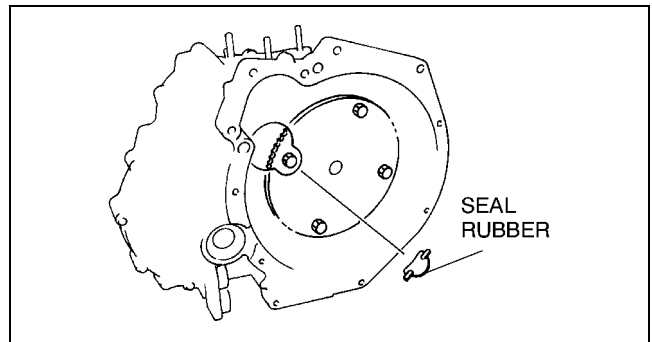

Y3E5614W007

2. Remove the torque converter nuts.

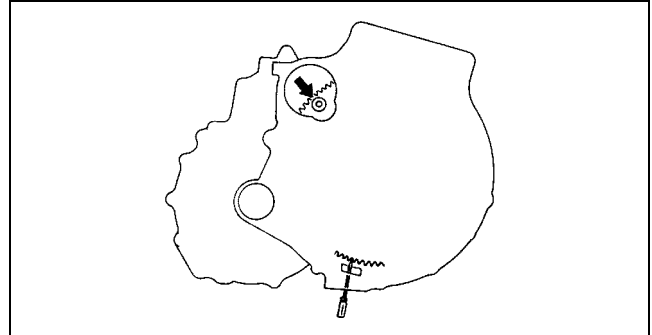

Y3E5614W008

## No.4 Engine Mount Removal Note

1. Support the engine by using the **SST** before removing the engine mounting member.
2. Remove the No.4 engine mount.

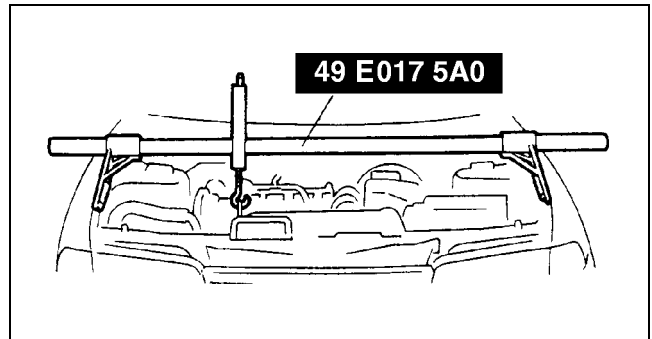

Z3U110WFK

## Transaxle Removal Note

1. Loosen the **SST (engine support)** and lean the engine toward the transaxle.
2. Support the transaxle on a jack.

### Warning

- Do not allow the transaxle to fall from the jack.

3. Remove the transaxle mounting bolts.

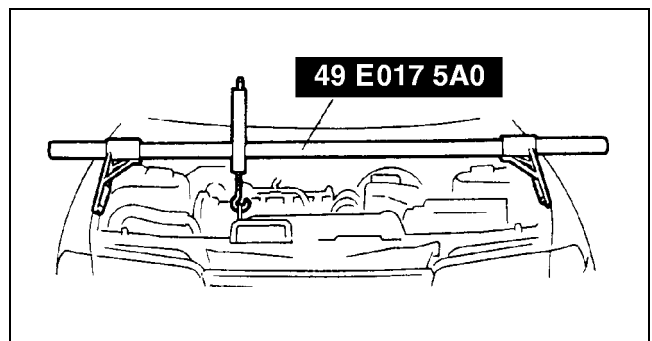

Z3U110WFK

# AUTOMATIC TRANSAXLE

4. Remove the transaxle.

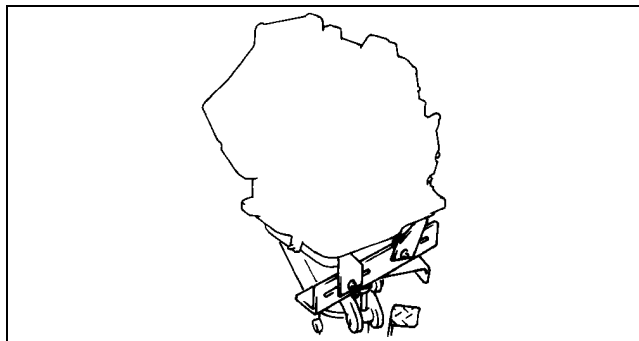

Y3E5614W010

## Transaxle Installation Note

### Warning

- Do not allow the transaxle to fall from the jack.

1. Set the transaxle on a jack and lift it.
2. Install the transaxle mounting bolts.

05-17

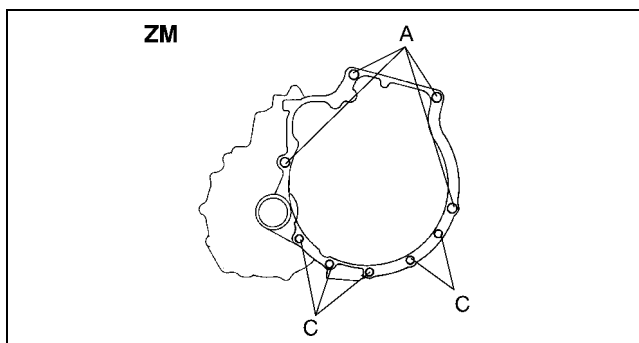

Y3E5614W011

### Tightening torque

A: 64—89 N·m {6.5—9.1 kgf·m, 48—65 ft·lbf}

B: 90—116 N·m {9.1—11.9 kgf·m, 66—86 ft·lbf}

C: 38—51 N·m {3.8—5.3 kgf·m, 28—38 ft·lbf}

D: 19—25 N·m {1.9—2.6 kgf·m, 14—18 ft·lbf}

3. Tighten the **SST** (49 E017 5A0) so that the engine is located at the specified position.

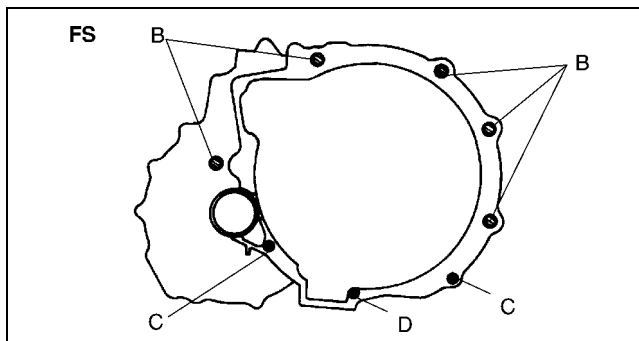

Z3U517W08

## No.2 Engine Mount, Engine Mounting Member, No.4 Engine Mount Installation Note

1. Verify that the engine mounting rubber is installed as shown.
2. Install the No.2 engine mount to the transaxle.
3. Put the No.2 engine mount stud bolts in the installing holes when installing the engine mounting member.

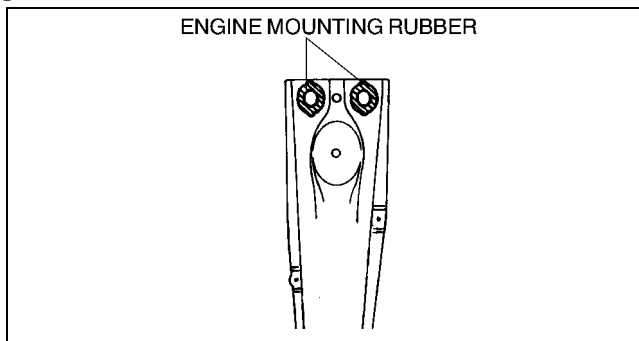

Y3E5614W013

## AUTOMATIC TRANSAXLE

4. Install the bolts and nuts A, then the nuts B as shown.

### Tightening torque

**A:** 67—93 N·m {6.8—9.5 kgf·m, 50—68 ft·lbf}

**B (ZM):** 67—93 N·m {6.8—9.5 kgf·m, 50—68 ft·lbf}

**B (FS):** 86—116 N·m {8.7—11.9 kgf·m, 63—86 ft·lbf}

5. Install the No.4 engine mount bracket by passing it through the stud bolt on the transaxle.
6. Match the positions of the No.4 engine mount bracket and the rubber, then temporarily tighten installation bolt A.
7. Tighten installation nut B, then tighten bolt A.

### Tightening torque

**A, B:** 67—93 N·m {6.8—9.5 kgf·m, 50—68 ft·lbf}

8. Remove the SST (49 E017 5A0).

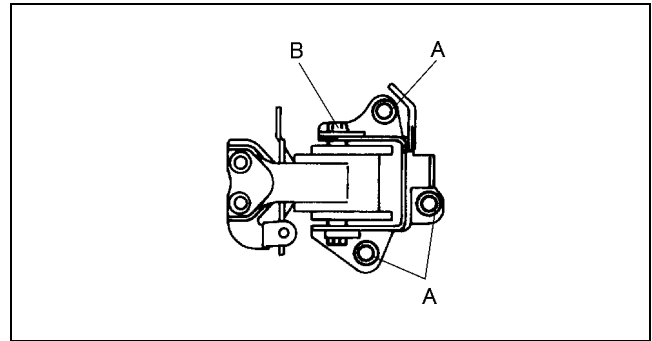
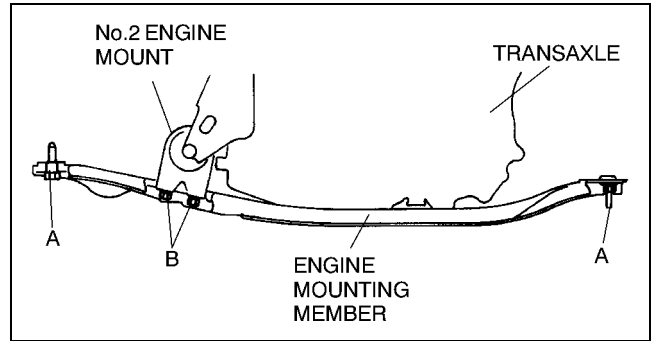

## OIL SEAL (TRANSAXLE) REPLACEMENT

1. Drain the ATF. (See 05-17-18 AUTOMATIC TRANSAXLE FLUID (ATF) REPLACEMENT.)
2. Remove the drive shaft. (See 03-13-9 DRIVE SHAFT REMOVAL/INSTALLATION.)
3. Remove the oil seal.
4. Using the SST and a hammer, tap a new oil seal in evenly until the SST contacts the transaxle case.
5. Coat the lip of the oil seal with transaxle oil.

### Caution

- The oil seal is easily damaged by the sharp edges of the drive shaft splines. Do not let the splines contact the oil seal.

6. Install the drive shaft. (See 03-13-9 DRIVE SHAFT REMOVAL/INSTALLATION.)
7. Add ATF to the specified level. (See 05-17-18 AUTOMATIC TRANSAXLE FLUID (ATF) REPLACEMENT.)
8. Carry out the mechanical system test. (See 05-17-11 MECHANICAL SYSTEM TEST.)

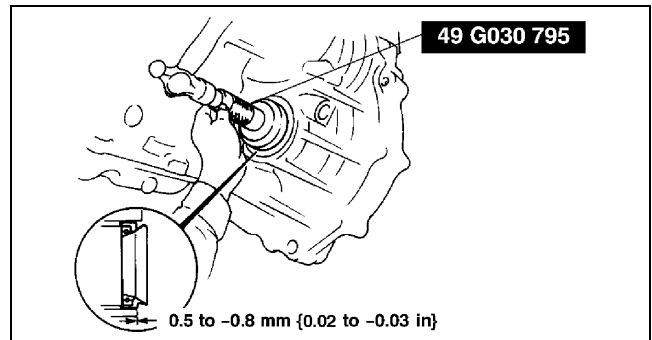

## CONTROL VALVE BODY REMOVAL/INSTALLATION

### On-vehicle Removal

#### Warning

- Using compressed air can cause dirt and other particles to fly out, causing injury to the eyes. Wear protective eye wear whenever using compressed air.

#### Caution

- Clean the transaxle exterior throughout with a steam cleaner or cleaning solvents before removal.
- If any old sealant gets into the transaxle during installation of the oil pan, trouble may occur in the transaxle. Remove any old sealant from the transaxle case and oil pan, and clean with cleaning fluids.

1. Disconnect the negative battery cable.
2. Drain the ATF into a separate suitable container. (See 05-17-18 AUTOMATIC TRANSAXLE FLUID (ATF) REPLACEMENT.)

# AUTOMATIC TRANSAXLE

3. Remove the splash shield.
4. Remove the oil pan.
5. Disconnect the solenoid connectors and TFT sensor connector and GND.

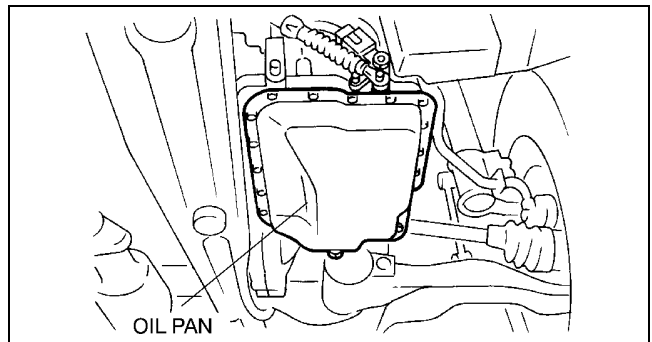

X3U517WBP

6. Remove the oil strainer.

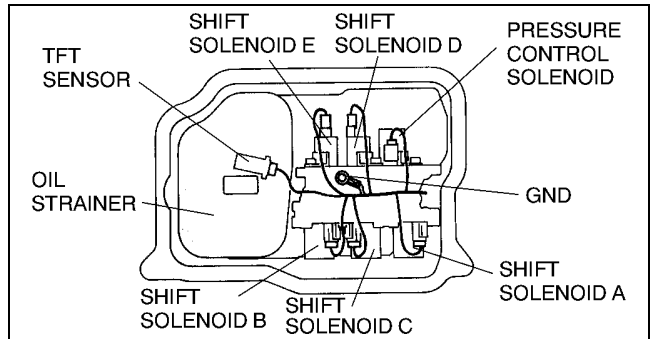

X3U517WBQ

7. Remove the control valve body component as shown.

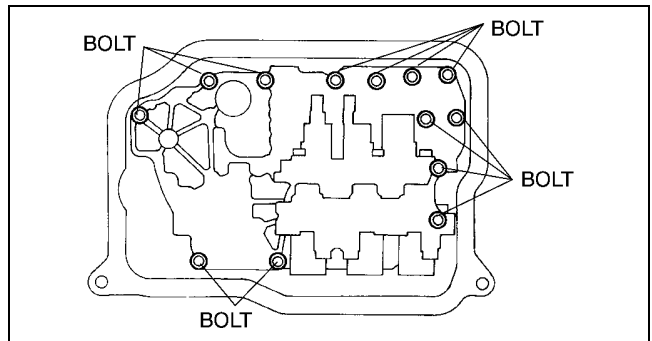

X3U517WBR

8. Remove the accumulators and accumulator springs.

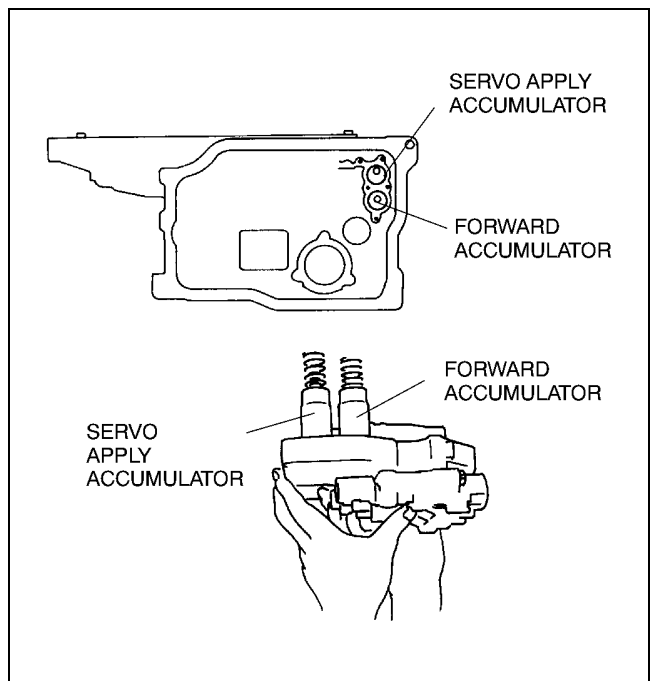

X3U517WCU



# AUTOMATIC TRANSAXLE

## On-vehicle Installation

### Caution

- Be sure to align the parking rod and the manual valve.

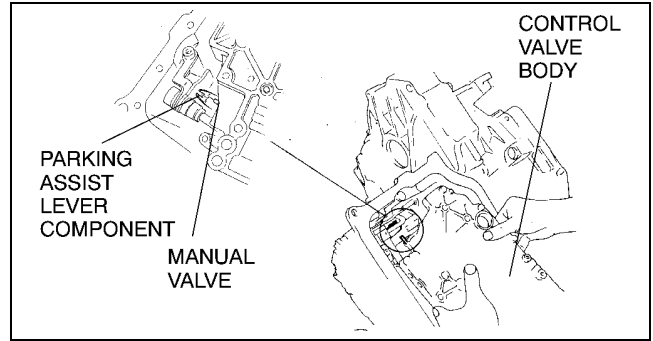

X3U517WBS

1. Install the accumulator springs and accumulator into the transaxle case.

### Accumulator springs specification

Spring	Outer diameter (mm {in})	Free length (mm {in})	No. of coils	Wire diameter (mm {in})
Servo apply accumulator or large spring	21.0 {0.827}	67.8 {2.67}	10.3	3.5 {0.14}
Servo apply accumulator or small spring	13.0 {0.512}	67.8 {2.67}	17.1	2.2 {0.087}
Forward accumulator or large spring	21.0 {0.827}	75.0 {2.95}	10.7	2.3 {0.091}
Forward accumulator or small spring	15.6 {0.614}	55.0 {2.17}	12.9	2.4 {0.094}

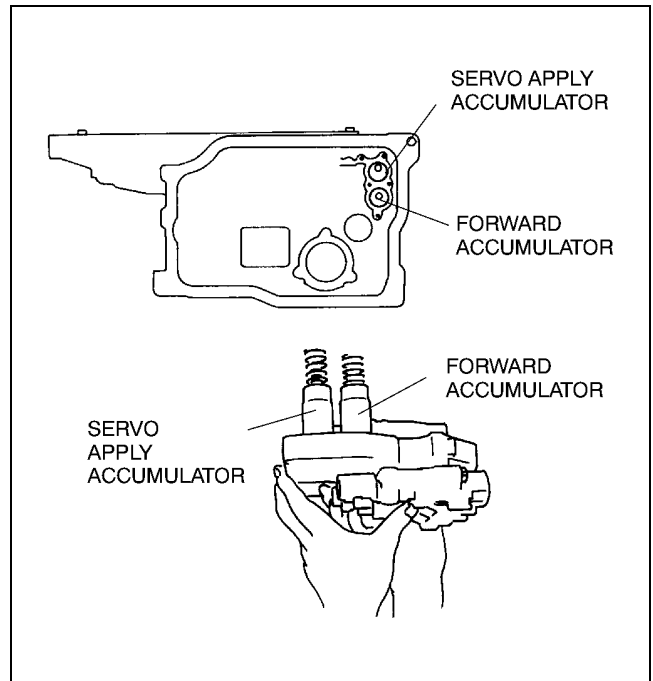

X3U517WBT

2. Install the control valve body component.

### Tightening torque

7.9—10.7 N·m {80—110 kgf·cm, 69.5—95.4 in·lbf}

### Bolt length (measured from below the head)

A: 70 mm {2.8 in}

B: 40 mm {1.6 in}

3. Install the oil strainer.

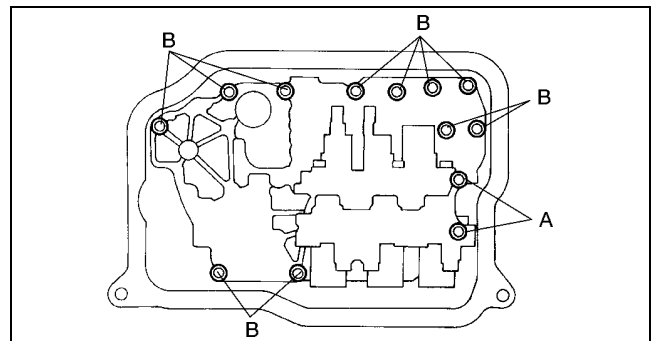

X3U517WBU

## AUTOMATIC TRANSAXLE

- Match the harness colors, then connect the solenoid connectors and TFT sensor connector.

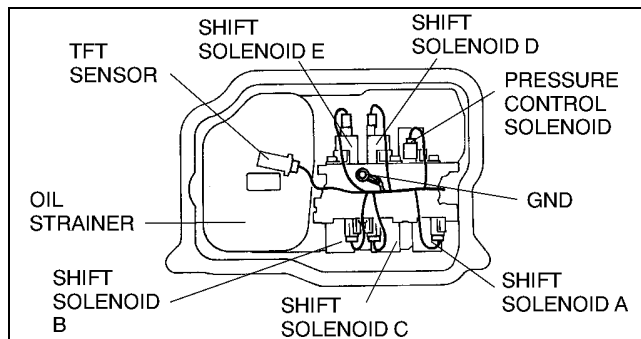

X3U517WBV

- Apply a light coat of silicon sealant to the contact surfaces of the oil pan and transaxle case.
- Install the oil pan.

### Tightening torque

7.9—10.7 N·m {80—110 kgf·cm, 69.5—95.4 in·lbf}

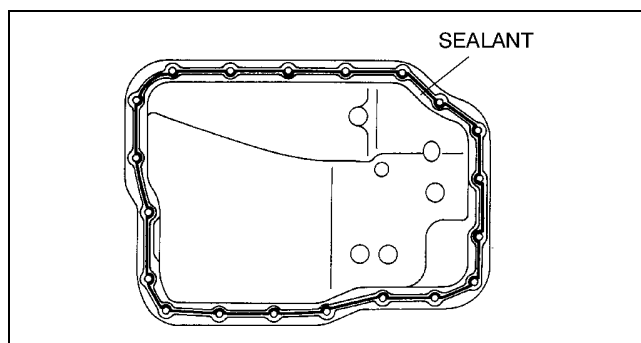

X3U517WBW

- Install the splash shield.
- Connect the negative battery cable.
- Add ATF, and with the engine idling, inspect the ATF level. (See 05-17-18 AUTOMATIC TRANSAXLE FLUID (ATF) REPLACEMENT.) (See 05-17-18 Automatic Transaxle Fluid (ATF) Level Inspection.)
- Carry out the mechanical system test. (See 05-17-11 MECHANICAL SYSTEM TEST.)
- Carry out the road test. (See 05-17-14 ROAD TEST.)

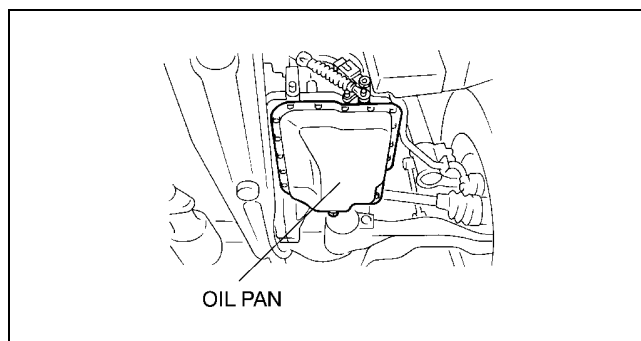

X3U517WBX

05-17

# AUTOMATIC TRANSAXLE

A3U051719900W01

## OIL COOLER FLUSHING

### Note

- The contaminated cooler line (oil pipes and hoses) and auxiliary cooler (if equipped) must be flushed completely when ATX is overhauled or replaced.

1. Remove the two oil cooler line hoses and apply air pressure of **200 kPa {2.0 kgf/cm<sup>2</sup>, 28 psi}** from the return hose (pipe) side.
  - If there is no ventilation, flush the oil cooler lines using the power-flushing tool. (See 05-17-40 Power Flushing)
  - If there is ventilation, go to next step.

### Caution

- **Power flushing should be performed very carefully when removing the accumulated debris from the fluid baffle, otherwise the debris cannot be removed or the problem becomes even worse.**

### Recommended Power-flushing Manufacturer

Manufacturer	Part number	Description
Kent Moore	J35944-AMAZ	Flushing kit or equivalent
OTC	60081	Portable torque converter, oil cooler cleaner or equivalent

2. Carry out the followings steps.

- (1) Remove the oil pan and inspect the fluid filter element from the front filter.
  - If the element is covered with too much debris or particles and cannot be seen, replace the oil cooler. (See 05-17-41 OIL COOLER REMOVAL/INSTALLATION.)
  - If the element can be seen, flush the oil cooler lines using the power-flushing tool.

### Note

- Performing back and reverse power flushing **2 times** each does not work because debris or particles flow out from the feed pipe side of ATX.

### Power Flushing Repair procedure

1. Before power flushing, inspect the hoses/lines and clamps. Power flushing must begin with back flushing followed by forward flushing to quickly dislodge the restriction.
  - If back flushing is not performed before forward flushing, the restriction could further reduce the ATF flow through the internal mesh type baffle of the cooler and flushing will not be effective or possible.

### Inspecting oil lines & clamps

1. Be sure to inspect the lines (hoses/pipes) for cuts, crimps (pinched), cracks or any other damage before reusing them.
  - If any problems exist, replace hoses and/or pipes.

### Caution

- **Always use new clamps when replacing hoses.**

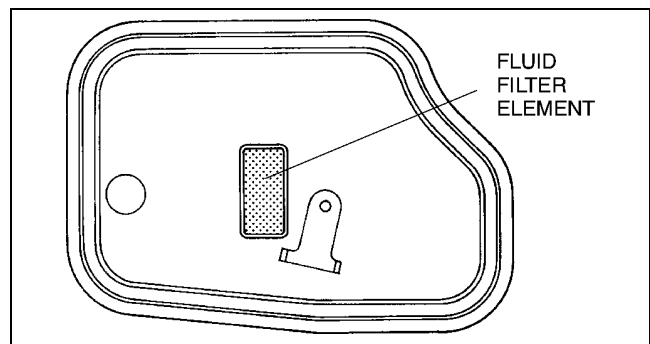
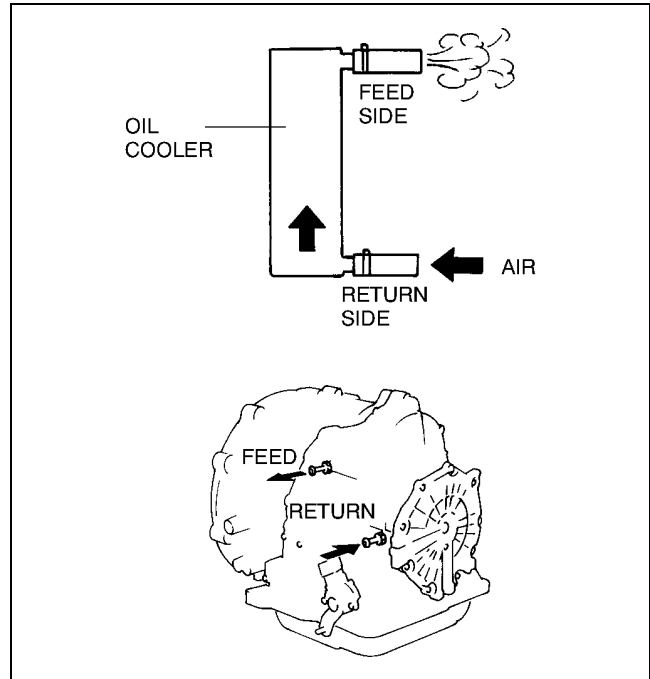

# AUTOMATIC TRANSAXLE

## Back flushing

1. Using the power flushing equipment manufacturer's instructions, connect equipment so the flushing fluid flows in the opposite direction of normal fluid flow.
2. Flush oil cooler/lines until discharge fluid is clean.

### Caution

- If the cooler can not be properly flushed using recommended equipment, send the radiator out for sublet cleaning or replace.

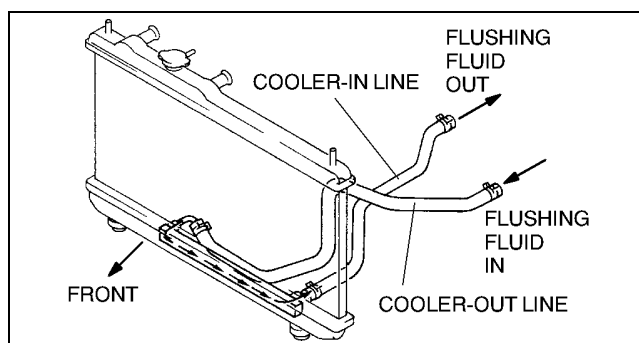

X3U517WD4

## Forward flushing

1. Connect power flushing equipment so the flushing fluid flows in the direction of normal fluid flow.
2. Flush oil cooler/lines until discharge fluid is clean.

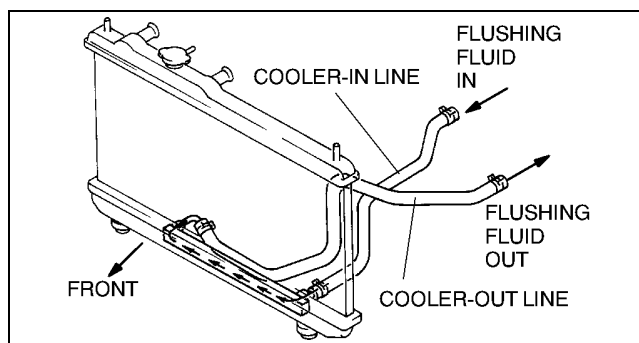

X3U517WD5

## OIL COOLER REMOVAL/INSTALLATION

A3U051719900W02

1. Remove in the order indicated in the table.
2. Install in the reverse order of removal.
3. Add engine coolant. (See 01-12-2 COOLING SYSTEM SERVICE WARNINGS.) (See 01-12-3 ENGINE COOLANT REPLACEMENT.)
4. Add ATF to the specified level. (See 05-17-18 AUTOMATIC TRANSAXLE FLUID (ATF) REPLACEMENT.)
5. Inspect for the coolant and ATF leakage.
6. Carry out the mechanical system test. (See 05-17-11 MECHANICAL SYSTEM TEST.)
7. Carry out the road test. (See 05-17-14 ROAD TEST.)

05-17

# AUTOMATIC TRANSAXLE

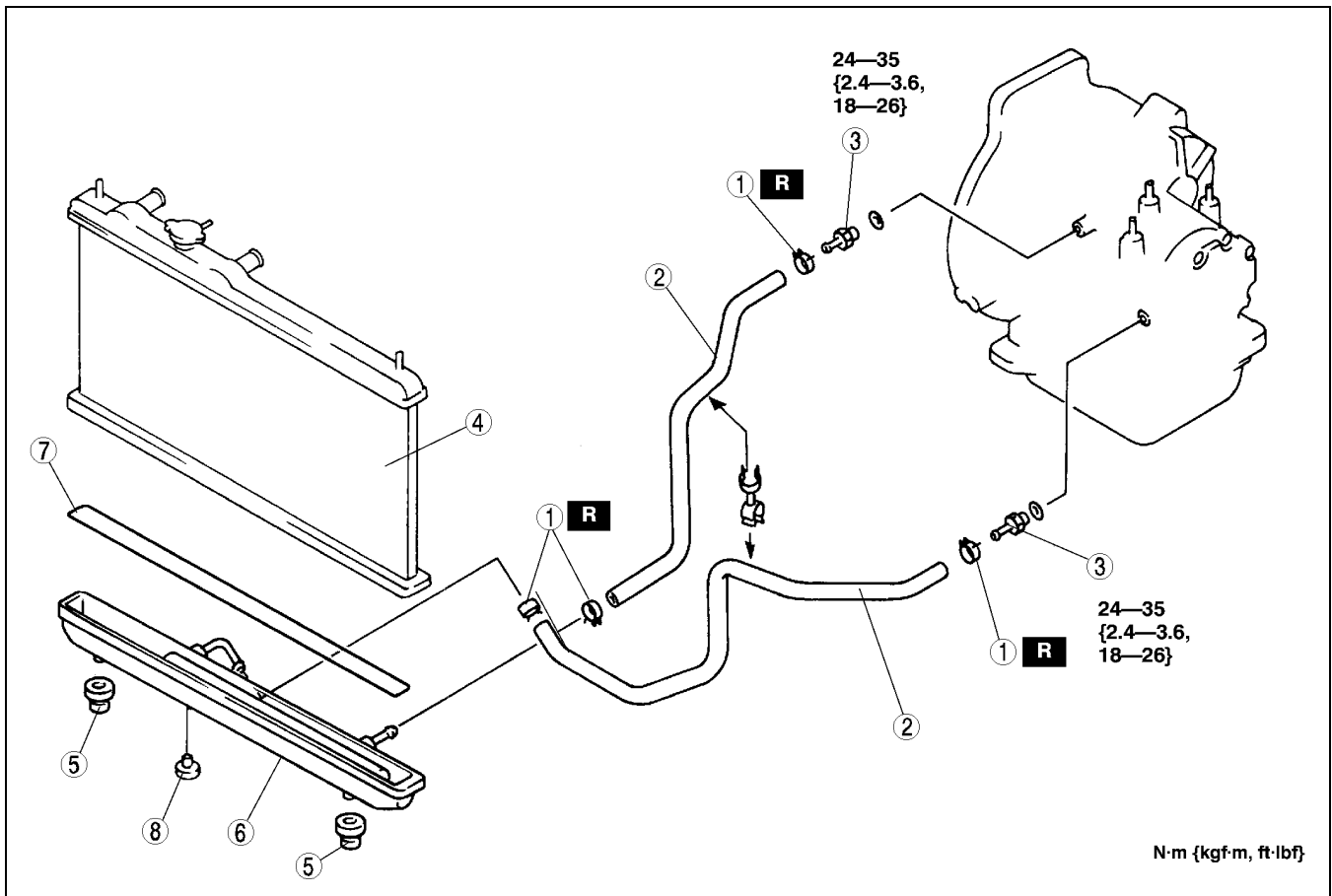

N·m {kgf·m, ft·lbf}

X3U517WC0

1	Hose clamp
2	Oil hose (See 05-17-45 Oil Hose Installation Note.)
3	Connector bolt
4	Radiator (See 05-17-45 Radiator Installation Note.)
5	Mount rubber

6	Radiator lower tank (in tank oil cooler) (See 05-17-42 Radiator Lower Tank (In Tank Oil Cooler) Removal Note.) (See 05-17-43 Radiator Lower Tank (In Tank Oil Cooler) Installation Note.)
7	O-ring
8	Drain cock

## Radiator Lower Tank (In Tank Oil Cooler) Removal Note

1. Inspect the height of the header tabs.
2. Insert the end of a medium tip screwdriver between the end of the header tab and the lower tank.

### Note

- Do not open more tabs than necessary for tank removal.

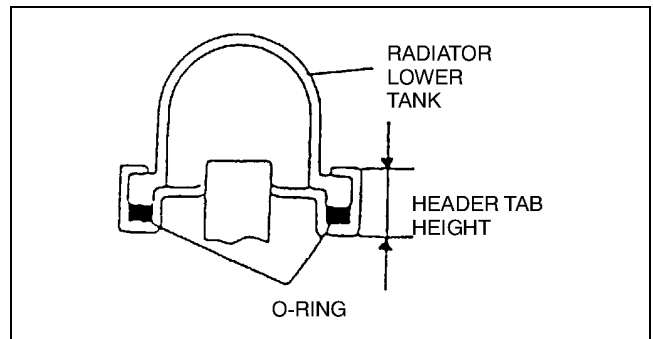

X3U517WC5

## AUTOMATIC TRANSAXLE

3. Pivot the screwdriver to pry the tab away from the tank and repeat the procedure for each tab.
4. Remove the radiator lower tank and O-ring (gasket) from the core header when all of the tabs are opened.

**Note**

- If any header tabs are missing from the core, replace the radiator.

5. Verify that the gasket surface of the radiator core header is clean and free of foreign material or damage.
6. Inspect the radiator lower tank for warping.
  - If it is warped, replace the radiator tank.

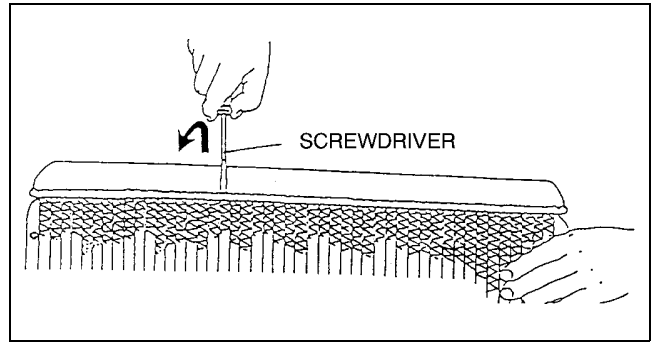

X3U517WC6

### Radiator Lower Tank (In Tank Oil Cooler) Installation Note

1. Install a new O-ring and ensure it is not twisted.

**Note**

- The old O-ring must be replaced.

2. Position the radiator tank in the original direction to the core using care not to scratch the tank sealing surface with the header tabs.

**Note**

- Step 3 will set jaw opening to the correct specification.

3. With the jaws of locking-type pliers (vise grips) closed and locked, turn the adjusting screw to position the jaws against the drill bit with the diameter measured (height) in removal procedure.
  - Tighten the lock nut on the adjusting screw against the handle to lock the adjustment in place.

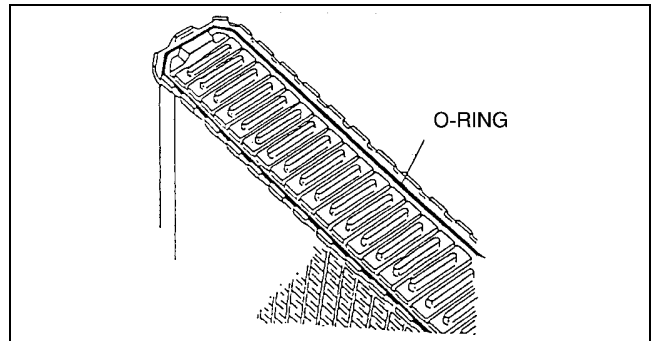

X3U517WC7

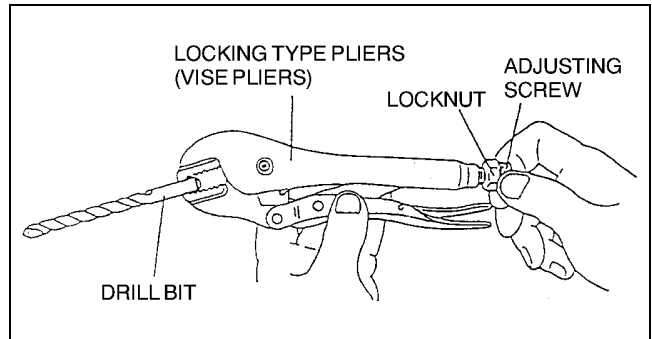

X3U517WC8

05-17

## AUTOMATIC TRANSAXLE

4. Squeeze the header tabs down in order as shown against the lip of radiator lower tank base with locking-type pliers while rotating the pliers toward the tank.

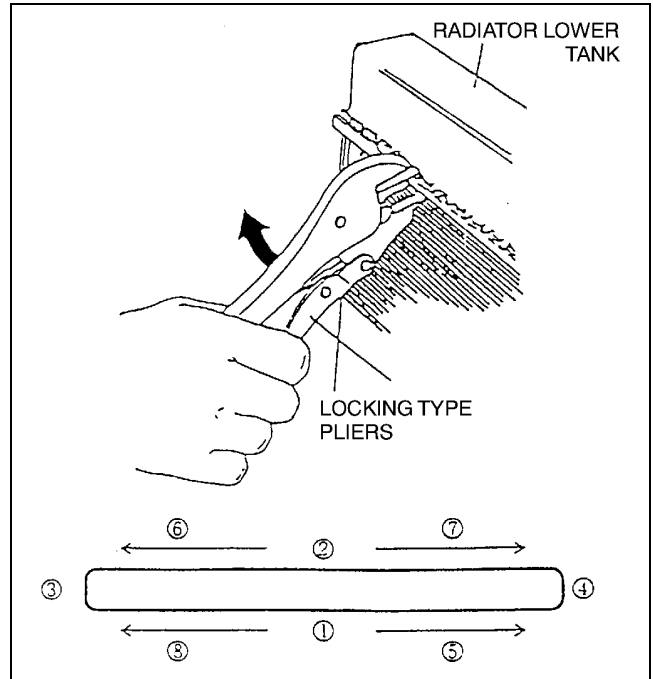

X3U517WC9

5. Verify the height of the header tabs is same as the height before removal.
6. Inspect for the leakage of radiator according to the following procedure.
- (1) Blind the radiator inlet and outlet.
  - (2) Blind the ATF cooler inlet and outlet.
  - (3) Connect a radiator tester.

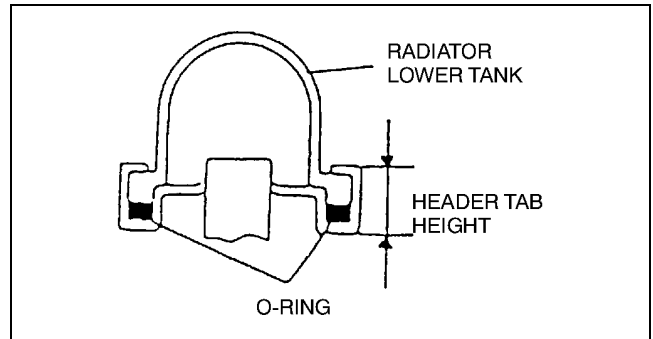

X3U517WCA

- (4) Apply pressure of **150 kPa {1.5 kgf/m<sup>2</sup>, 21 psi}** and verify that the pressure is held.

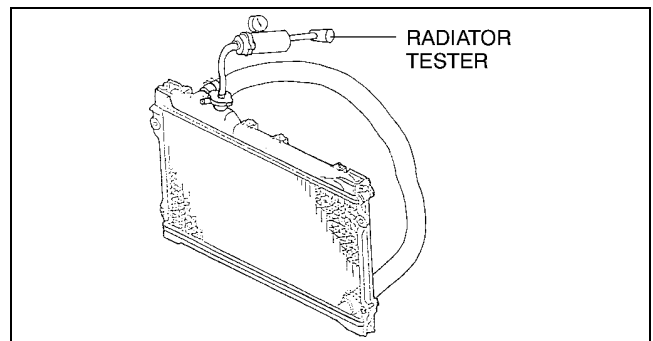

X3U517WCB

- (5) Put the radiator into water slowly with the radiator tester connected.
- (6) Inspect for air leakage.

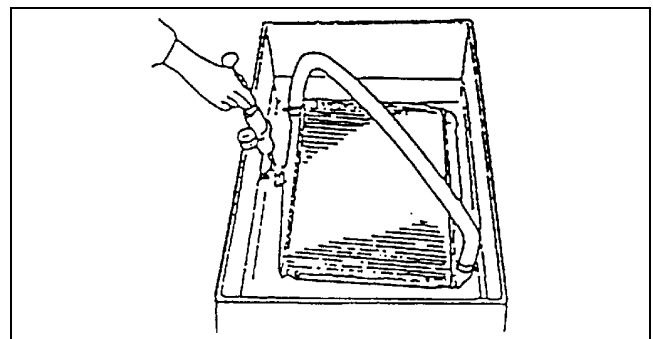

X3U517WCC

# AUTOMATIC TRANSAXLE

## Radiator Installation Note

1. The ATX oil cooler flushing must be performed whenever a transaxle is removed for service because the existing fluid may be contaminated, and to prevent contamination of new fluid. The flushing must be performed after installation of the overhauled or replaced transaxle. (See 05-17-40 OIL COOLER FLUSHING)

## Oil Hose Installation Note

1. Apply compressed air to cooler-side opening more than **1 minute**, and blow any remaining grime and foreign material from the cooler pipes.

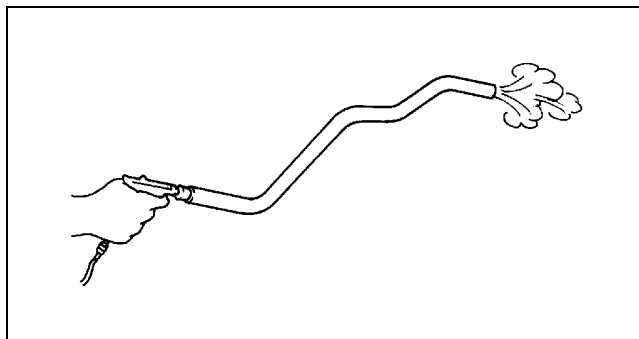

X3U517WC1

05-17

2. Align the marks, and slide the oil hose onto the oil pipe until it is fully seated as shown.

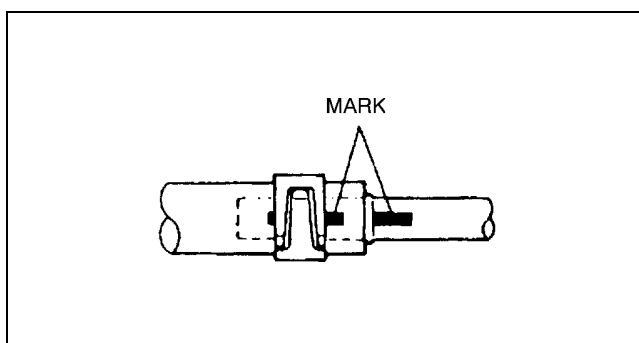

Y3U517WAN

3. Install the hose clamp onto the hose.
  - If reusing the hose, install a new hose clamp exactly on the mark left by the previous hose clamp.
4. Verify that the hose clamp does not interfere with any other components.

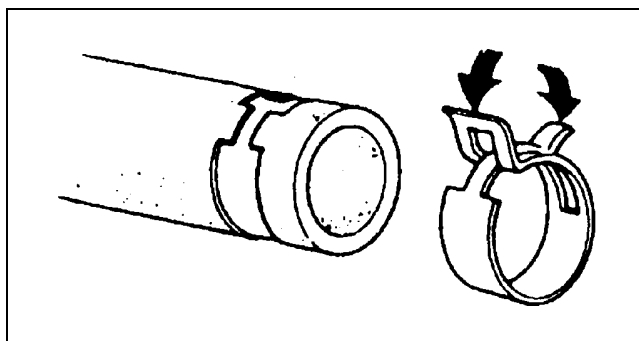

X3U517WC3



# AUTOMATIC TRANSAXLE

A3U051719020W01

## DRIVE PLATE REMOVAL/INSTALLATION

1. Remove the transaxle. (See 05-17-31 AUTOMATIC TRANSAXLE (ATX) REMOVAL/INSTALLATION.)
2. Remove in the order indicated in the table.
3. Install in the reverse order of removal.
4. Install the transaxle. (See 05-17-31 AUTOMATIC TRANSAXLE (ATX) REMOVAL/INSTALLATION.)

1	Drive plate mounting bolt (See 05-17-46 Drive Plate Mounting Bolts Removal Note.) (See 05-17-46 Drive Plate Mounting Bolts Installation Note.)
2	Washer
3	Adapter
4	Drive plate

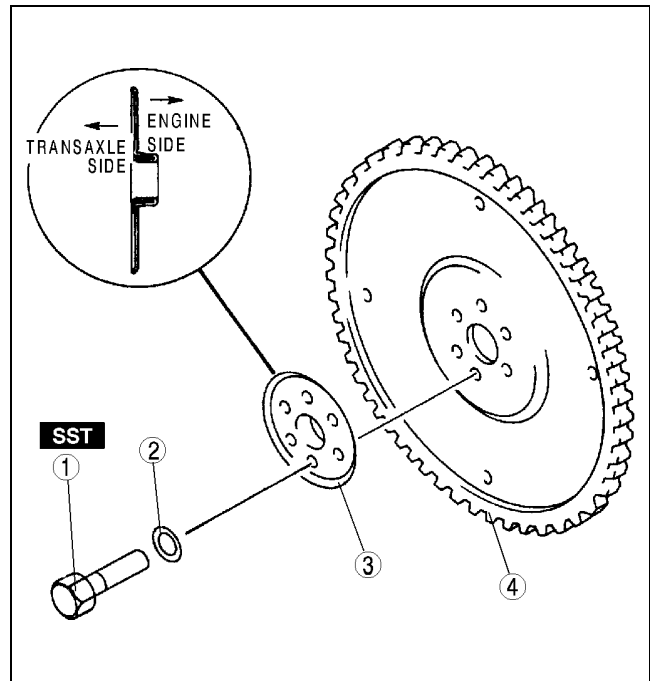

X3U517WCD

### Drive Plate Mounting Bolts Removal Note

1. Set the **SST** or equivalent against the drive plate.
2. Remove the drive plate mounting bolts.

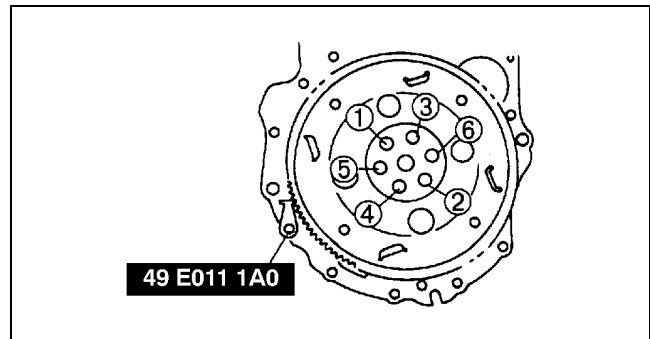

X3U517WCE

### Drive Plate Mounting Bolts Installation Note

#### Caution

- If the bolts are reused, remove the oil sealant from the bolt threads. Tightening a bolt that has old sealant on it can cause thread damage.

1. Remove the sealant from the bolts hole in the crankshaft and from the drive plate mounting bolts.

#### Note

- If all the previous sealant cannot be removed from a bolt, replace the bolts.
- Do not apply sealant if new bolts are used.

2. Install the drive plate.
3. Install the adapter.
4. Apply sealant to the drive plate mounting bolts and install them.
5. Set the **SST** or equivalent against the drive plate.

#### Caution

- When installing sealant covered bolts tighten them immediately. Leaving these bolts in a half installed condition could cause them to be stuck that way, due to the natural hardening of the sealant.

## AUTOMATIC TRANSAXLE

6. Tighten the drive plate installation bolts in 2 or 3 steps as shown.

### Tightening torque

97—102 N·m {9.8—10.5 kgf·m, 70.9—75.9  
ft·lbf}

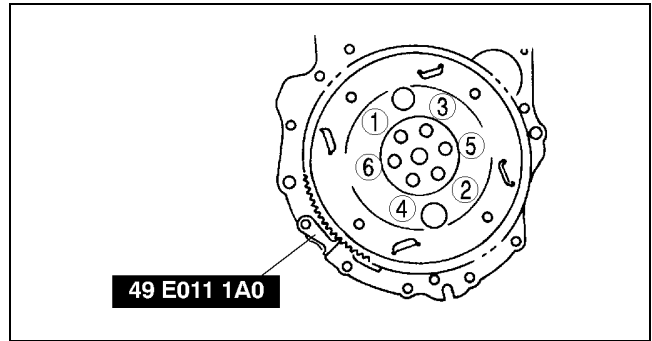

X3U517WCF

05-17

# 05-18 AUTOMATIC TRANSAXLE SHIFT MECHANISM

**AUTOMATIC TRANSMISSION SHIFT**

**MECHANISM LOCATION INDEX** . . . . . 05-18-1  
**INTERLOCK CABLE INSPECTION** . . . . . 05-18-1  
**SELECTOR LEVER INSPECTION** . . . . . 05-18-2  
**SELECTOR LEVER ADJUSTMENT** . . . . . 05-18-2  
**SELECTOR LEVER**  
**REMOVAL/INSTALLATION** . . . . . 05-18-3  
 Selector Cable Removal Note . . . . . 05-18-4

Interlock Cable and Lock Unit  
 Installation Note . . . . . 05-18-4  
 Selector Cable Installation Note . . . . . 05-18-6  
**SELECTOR LEVER**  
**DISASSEMBLY/ASSEMBLY** . . . . . 05-18-8  
 Connector Disassembly Note . . . . . 05-18-8  
 Cam Assembly Note . . . . . 05-18-9

**AUTOMATIC TRANSMISSION SHIFT MECHANISM LOCATION INDEX**

A3U051864350W01

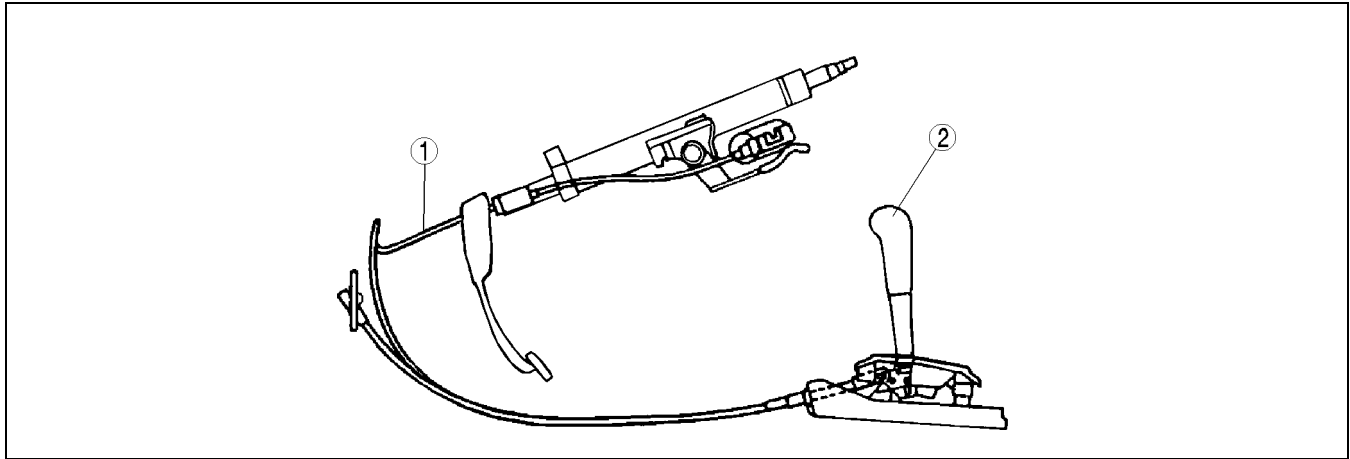

Z3U518W01

**05-18**

1	Interlock cable (See 05-18-1 INTERLOCK CABLE INSPECTION)
---	---

2	Selector lever (See 05-18-3 SELECTOR LEVER REMOVAL/INSTALLATION) (See 05-18-2 SELECTOR LEVER INSPECTION) (See 05-18-2 SELECTOR LEVER ADJUSTMENT) (See 05-18-8 SELECTOR LEVER DISASSEMBLY/ASSEMBLY)
---	--

**INTERLOCK CABLE INSPECTION**

A3U051846300W01

1. Remove the interlock cable and lock unit. (See 05-18-3 SELECTOR LEVER REMOVAL/INSTALLATION.)
  - If the slider pin protrusion is as specified below (dimension A), verify that the interlock cable moves freely in the lock unit.
  - If not as specified, replace the interlock cable.
2. Install the interlock cable and lock unit. (See 05-18-4 Interlock Cable and Lock Unit Installation Note.)

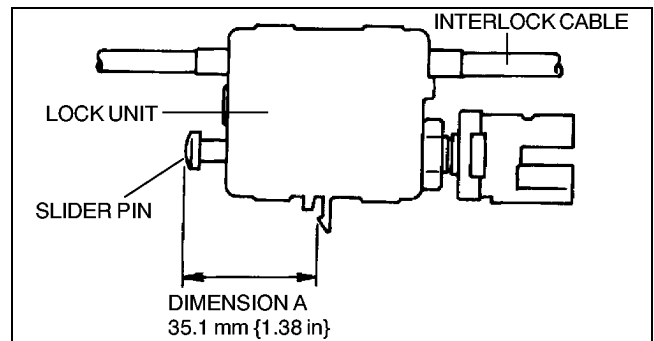

X3U518WA0

# AUTOMATIC TRANSAXLE SHIFT MECHANISM

## SELECTOR LEVER INSPECTION

A3U051846102W01

1. Turn the ignition switch to the ON position (engine off).
2. With the brake pedal depressed, verify that a "click" sound is heard at each range when shifted in the pattern shown.
3. Verify that the selector lever can only be shifted as shown.
4. Verify that a "click" sound is heard at each position when shifted from P position to 1 range.
5. Verify that the positions of the selector lever and the indicator are aligned.
6. Verify that the position of the selector lever and the selector illumination light correspond.
  - If not as specified, adjust the TR switch. (See 05-17-23 TRANSAXLE RANGE (TR) SWITCH ADJUSTMENT.)
7. Verify that the vehicle operates in each selected range.

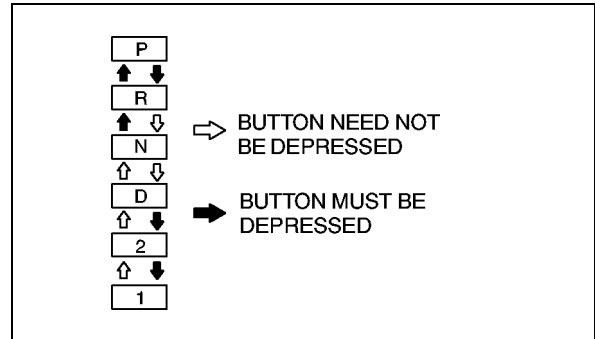

X3U518WA1

## SELECTOR LEVER ADJUSTMENT

A3U051846102W02

1. Remove the center console.
2. Shift the selector lever to the P position.
3. Unlock the lock piece of the selector cable (selector lever side) in the order shown in the figure.
4. Verify that the manual shaft is at the P position.
5. Lock the lock piece of the selector cable (selector lever side) in the order shown in the figure.
6. Install the center console.
7. Shift the selector lever from P position to 1 range, and make sure that there are no other components in that area to interfere with the lever.

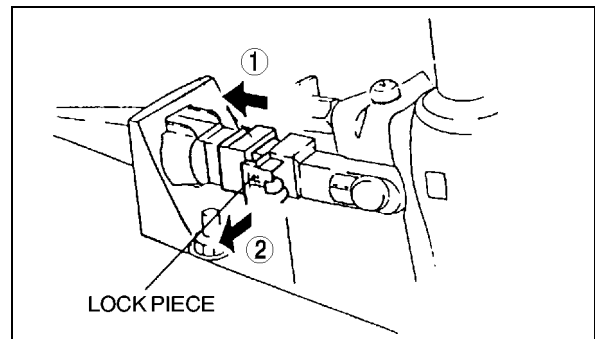

X3U518WA2

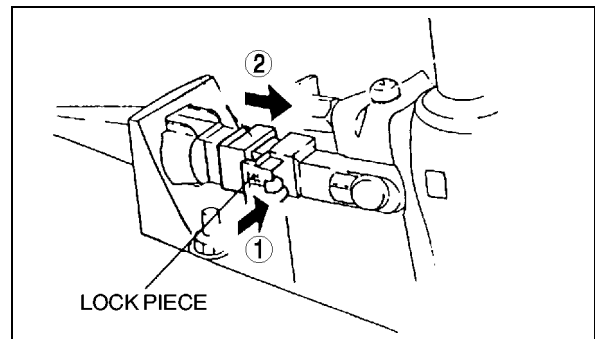

X3U518WA3

# AUTOMATIC TRANSAXLE SHIFT MECHANISM

A3U051846102W03

## SELECTOR LEVER REMOVAL/INSTALLATION

1. Disconnect the negative battery cable.
2. Remove the center console.
3. Disconnect the brake switch connector.
4. Remove in the order indicated in the table.
5. Install in the reverse order of removal.

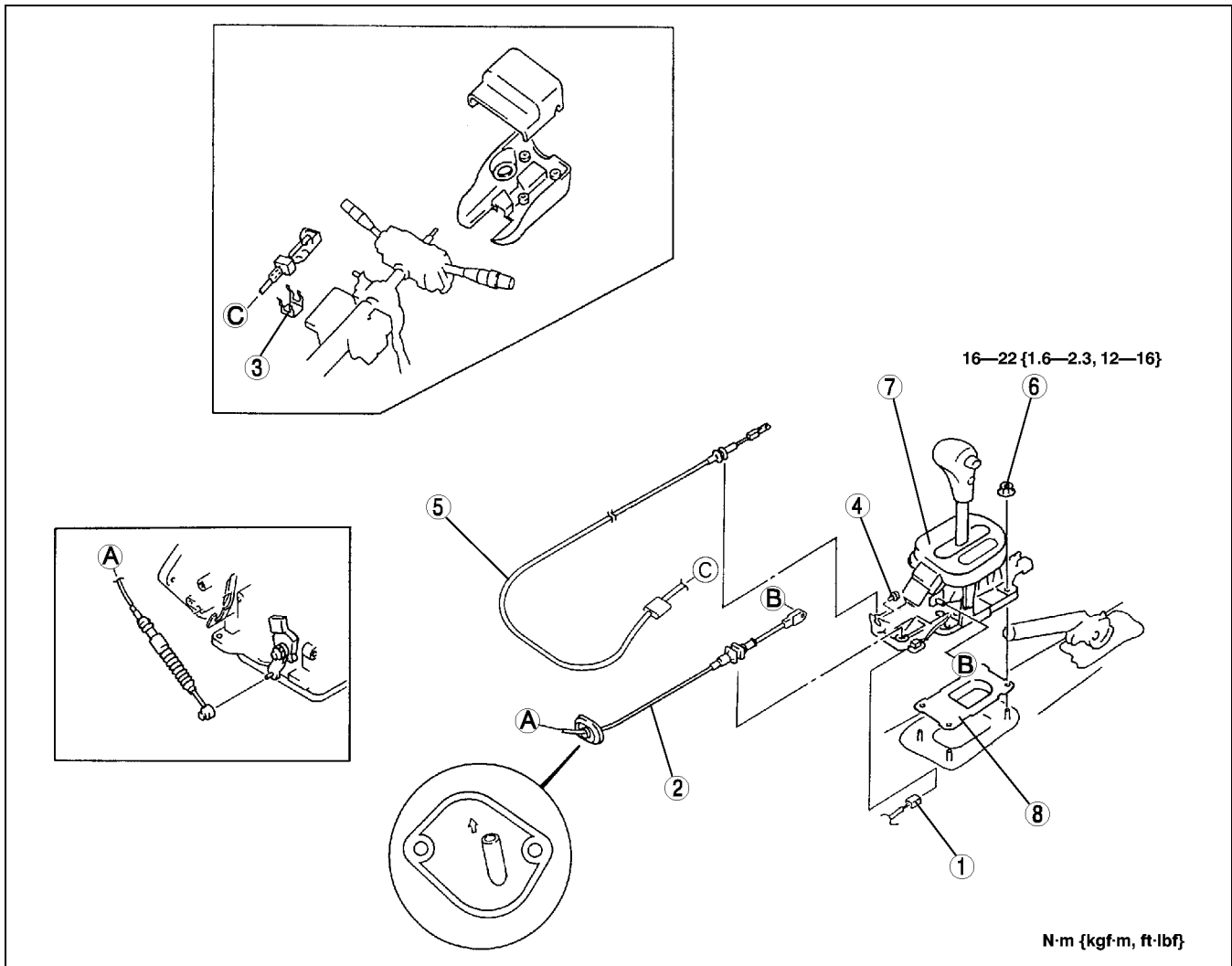

N·m {kgf·m, ft·lbf}

X3U518WA4

1	Connector
2	Selector cable (See 05-18-4 Selector Cable Removal Note.) (See 05-18-6 Selector Cable Installation Note.)
3	Clip
4	Clip

5	Interlock cable and lock unit (See 05-18-4 Interlock Cable and Lock Unit Installation Note.)
6	Nut
7	Selector lever
8	Seal rubber

05-18

# AUTOMATIC TRANSAXLE SHIFT MECHANISM

## Selector Cable Removal Note

### Note

- Remove the clip shown in the figure before removing the selector cable from manual shaft lever.

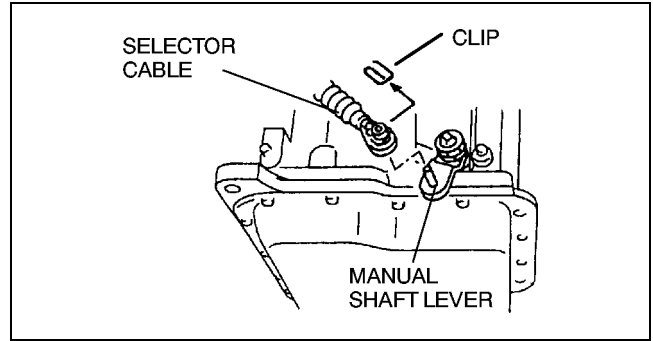

X3U518WA4

## Interlock Cable and Lock Unit Installation Note

- Verify that the ignition switch is at ACC position, and shift the selector lever to P position.
- Press the lock unit onto the brake pedal stopper bracket.
- From this position, slide the lock unit to fix the lock unit hook into the bracket hole securely as shown in the figure.
- Install the interlock cable to the key cylinder.
- Slide the outer casing to the key cylinder. Verify that the outer casing hook is secured in the cylinder hole.

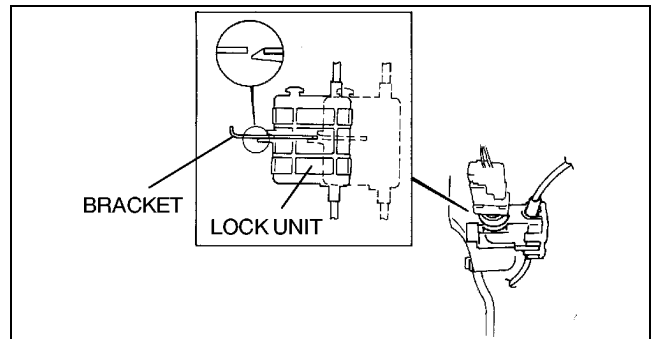

X3U518WA5

- Insert the clip over the convex part of the outer casing.

### Caution

- Allowing the interlock cable to become bent or twisted during installation can affect the lock unit operation.

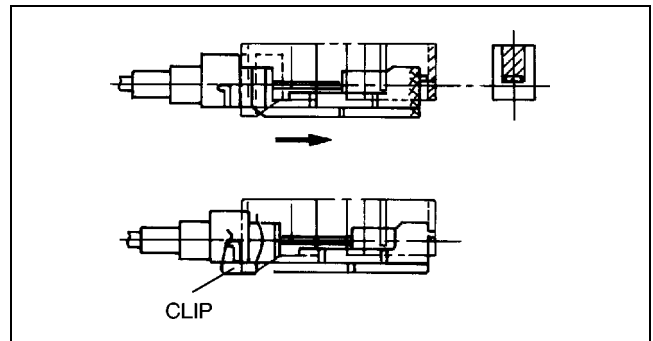

X3U518WA6

- Install the interlock cable end onto the cam pin on the selector lever.

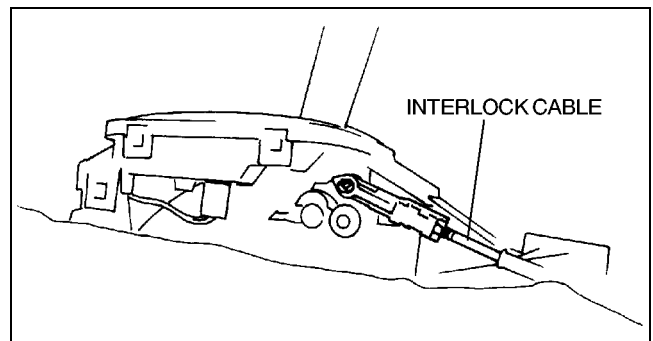

X3U518WA7

## AUTOMATIC TRANSAXLE SHIFT MECHANISM

8. Fit the interlock cable in the U-groove in the selector lever base plate, and install the clip.

### Note

- Steps 9—12 are for the interlock cable replacement only.

### Caution

- **Applying load to the interlock cable while pressing the lock piece in can affect the lock unit operation.**

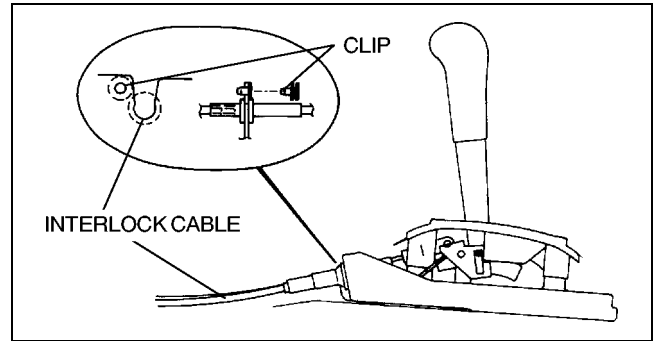

9. Press the interlock cable lock piece in until it is locked.

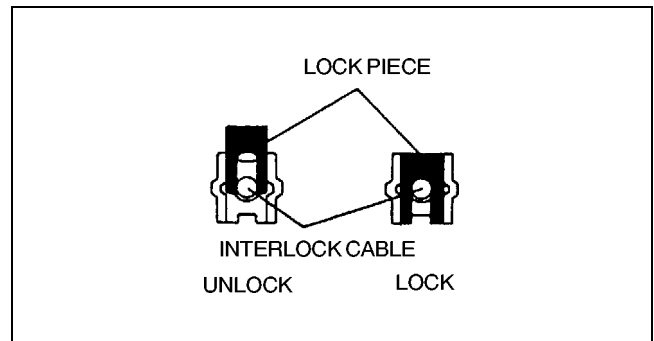

10. Screw the brake switch into the slider pin of the lock unit as far as possible.

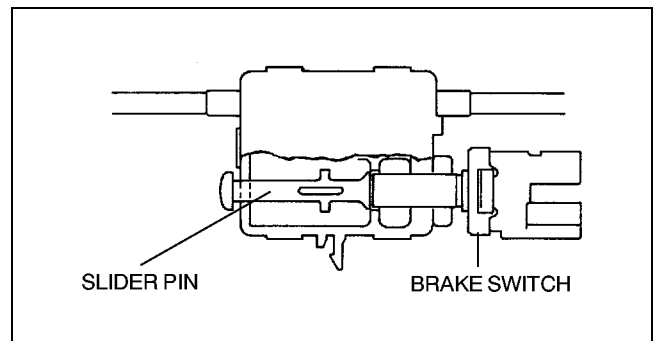

11. From this position, turn the brake switch counterclockwise **about 90 degrees**, then tighten the lock nut.

### Tightening torque

**13.8—17.6 N·m {140—180 kgf·cm, 122—156 in·lbf}**

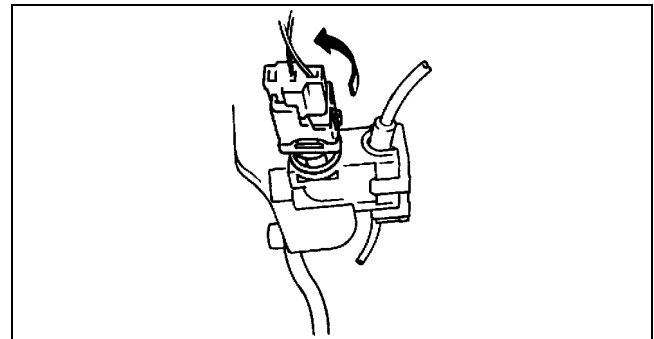

12. Remove the lock unit pin in the order shown in the figure.

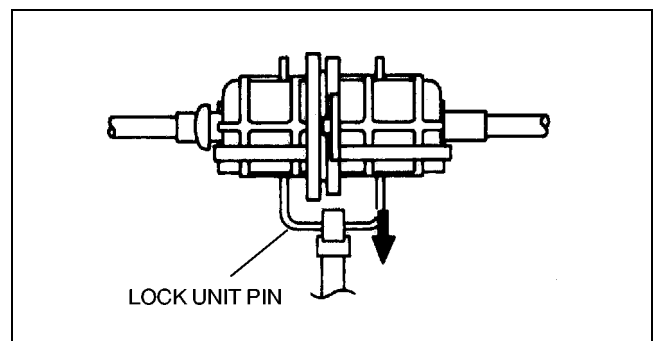

# AUTOMATIC TRANSAXLE SHIFT MECHANISM

## Selector Cable Installation Note

### Caution

- Do not apply load to the manual shaft after manual shaft is shifted to P position. Otherwise, the transaxle may be damaged.

1. Turn the manual shaft to the converter housing side fully, to set the P position.

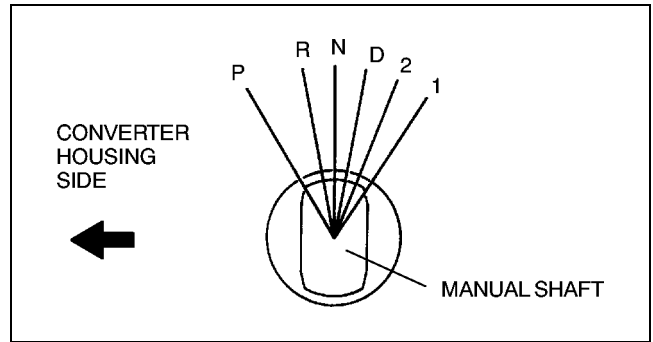

X3U518WAD

2. Install the selector cable to the selector lever.

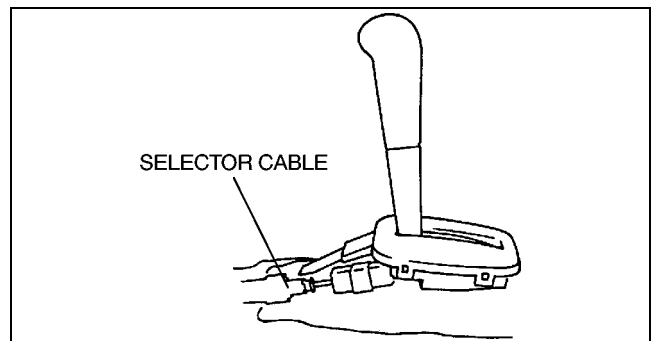

X3U518WAE

### Caution

- Bending the selector cable in the manner shown in the figure will damage the cable and it may become loose when shifted. When installing the selector cable, hold it straight.

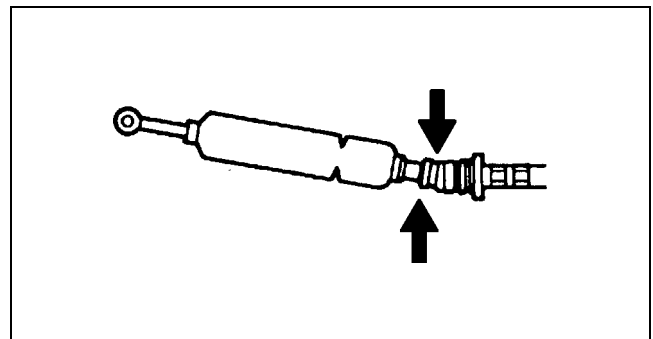

X3U518WAF

3. Install the clip as shown in the figure.

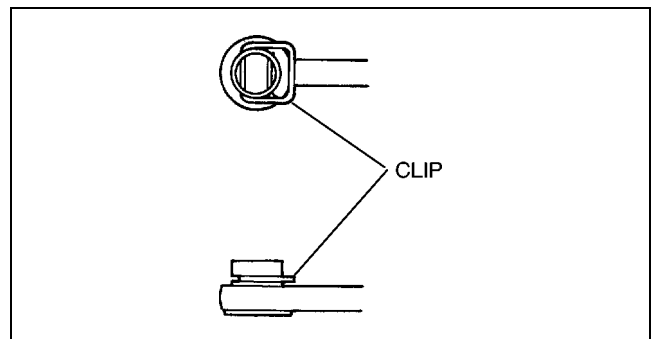

X3U518WAQ



## AUTOMATIC TRANSAXLE SHIFT MECHANISM

### Note

- Install the selector cable to the manual shaft lever with the spring side of the selector cable end facing the front of the vehicle.
4. Install the selector cable to the manual shaft lever in such a way that the selector cable does not bear a load.
  5. Confirm that the end of the manual shaft lever sticks out of the end of the selector cable.
  6. Install the selector cable to the cable bracket.
  7. Verify that the selector lever is at P position.

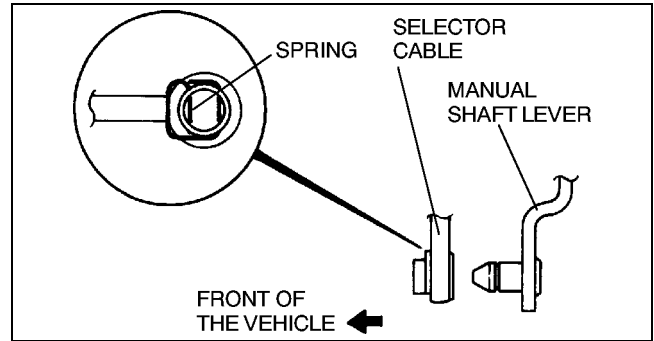

X3U518WAG

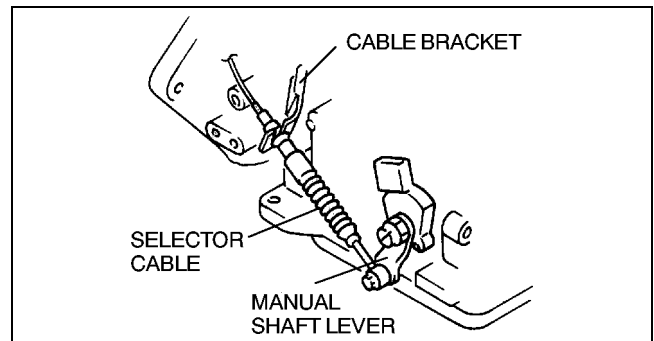

X3U518WAH

8. Unlock the lock piece of the selector cable (selector lever side) in the order shown in the figure.
9. Shift the selector lever from P position to 1 range, and make sure that there are no other components in that area to interfere with the lever.

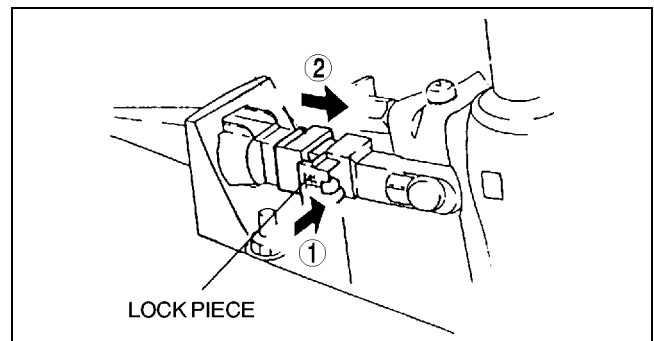

X3U518WAJ

05-18

# AUTOMATIC TRANSAXLE SHIFT MECHANISM

A3U051846102W04

## SELECTOR LEVER DISASSEMBLY/ASSEMBLY

1. Disassemble in the order indicated in the table.
2. Assemble in the reverse order of disassembly.

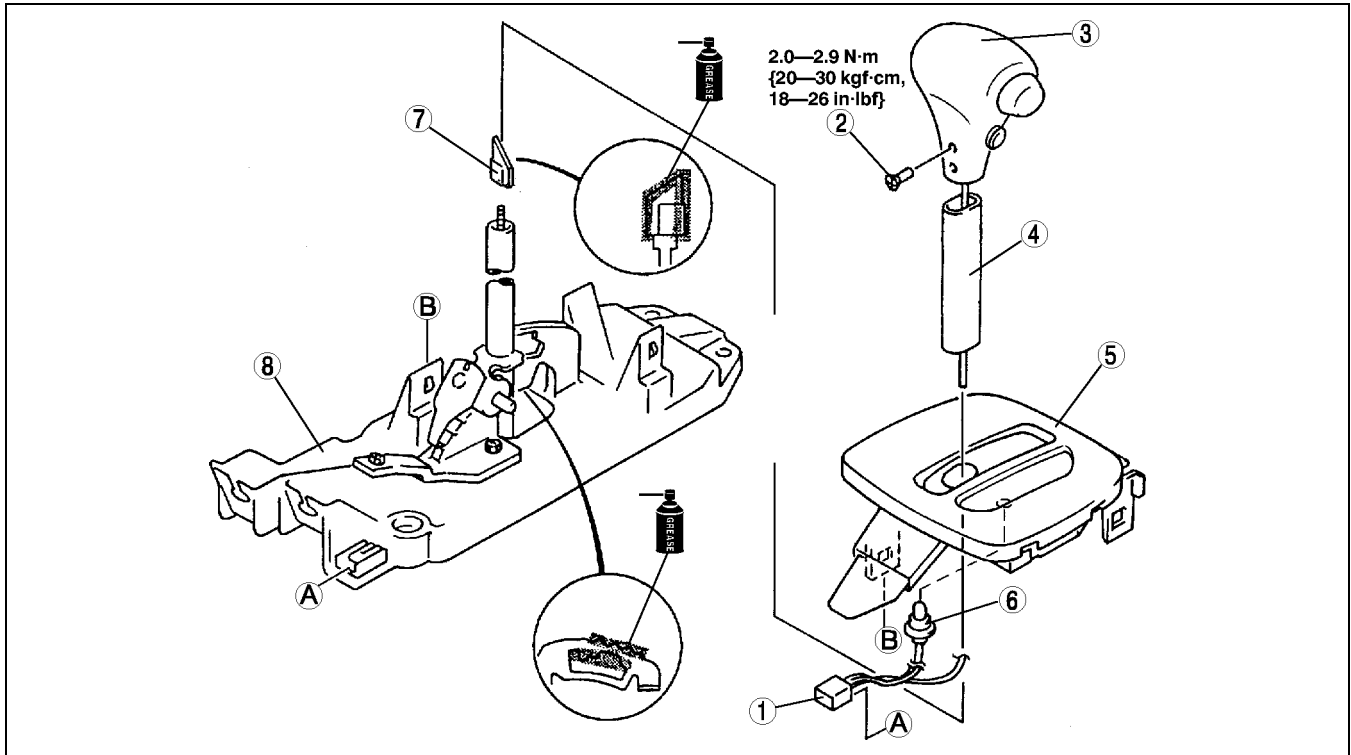

X3U518WAK

1	Connector (See 05–18–8 Connector Disassembly Note.)
2	Screw
3	Selector lever knob
4	Cover

5	Indicator panel
6	Selector illumination light
7	Cam (See 05–18–9 Cam Assembly Note.)
8	Selector lever

### Connector Disassembly Note

1. Insert a thin piece of metal from the terminal side of the connector, and press down the terminal locking tab.
2. Pull the terminal out of the connector.

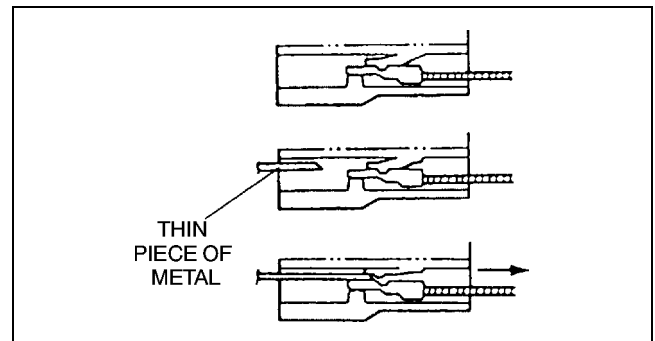

X3U518WAL

# AUTOMATIC TRANSAXLE SHIFT MECHANISM

## Cam Assembly Note

1. Loosely install the cam to the push rod.

### Note

- Clearance can be reduced by turning the cam clockwise.
2. Adjust the clearance between the guide plate and the guide pin by turning the cam.
  3. Install the selector lever knob and verify that the clearance is as specified.
    - If not, repeat from Step 2.
  4. Remove the selector lever knob.

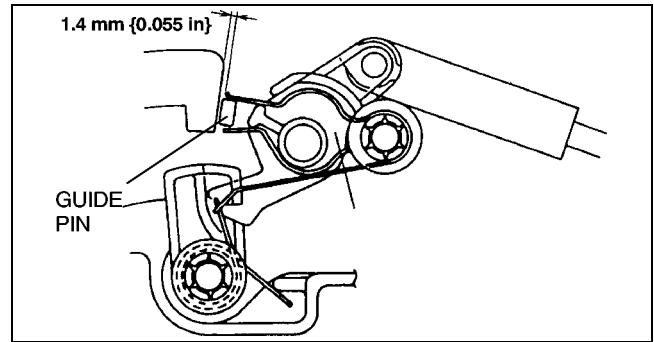

5. Apply grease to the cam as shown.

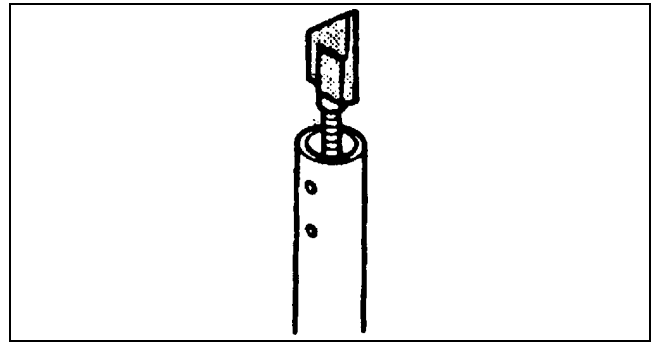

05-18

# TECHNICAL DATA

## 05-50 TECHNICAL DATA

TRANSMISSION/TRANSAXLE  
TECHNICAL DATA . . . . . 05-50-1

### TRANSMISSION/TRANSAXLE TECHNICAL DATA

A3U055001024W01

Item		Engine		
		ZM	FS	
<b>CLUTCH</b>				
Clutch pedal	Full stroke	(mm {in})	130—140 {5.12—5.51}	
	Height (from set plate)	(mm {in})	210—215 {8.27—8.46}	
	Free play	(mm {in})	0.7—3.5 {0.03—0.13}	
Clutch cover	Diaphragm spring fingers	Depth	(mm {in}) 0.5 {0.020}	
		Misalignment	(mm {in}) 0.6 {0.024}	
	Maximum clearance of flatness of the pressure plate	(mm {in})	0.5 {0.020}	
Clutch disc	Minimum thickness	(mm {in})	0.3 {0.012}	
	Run out limit	(mm {in})	0.7 {0.028}	
Flywheel	Run out limit	(mm {in})	0.2 {0.008}	
<b>MANUAL TRANSAXLE</b>				
<b>Transaxle type</b>		<b>F25M-R</b>	<b>G15M-R</b>	
Transaxle oil	Grade		API Service GL-4 or GL-5	
	Viscosity	All season	SAE 75W—90	
		Above 10 °C {50 °F}	SAE 80W—90	
Capacity (Approx. quantity) (L {US qt, Imp qt})		2.68 {2.83, 2.36}		
<b>AUTOMATIC TRANSAXLE</b>				
<b>Transaxle type</b>		<b>FN4A-EL</b>		
Line pressure (kPa {kgf/cm <sup>2</sup> , psi})	D, 2, 1 range	Idle	330—470 {3.4—4.7, 49—66}	
		Stall	1,200—1,360 {12.3—13.8, 175—196}   1,160—1,320 {11.9—13.4, 170—190}	
	R position	Idle	490—710 {5.0—7.2, 72—100}	
		Stall	1,470—1,690 {15.0—17.2, 214—244}	
Engine stall speed (rpm)	D, 2, 1 range	2,300—2,600	2,200—2,500	
	R position	2,300—2,600	2,200—2,500	
Time lag (sec)	N→D	0.4—0.7		
	N→R	0.4—0.7		
Transaxle fluid temperature (TFT) sensor (kilohm)	-20 °C {-4 °F}	236—324		
	0 °C {32 °F}	84.3—110		
	20 °C {68 °F}	33.5—42.0		
	40 °C {104 °F}	14.7—17.9		
	60 °C {140 °F}	7.08—8.17		
	80 °C {176 °F}	3.61—4.15		
	100 °C {212 °F}	1.96—2.24		
Input/turbine speed sensor (ohm)	ATF temperature: -40—160 °C {-40—320 °F}	250—600		
	Solenoid valve (ohm)	Shift solenoid A	1.0—4.2	
		Shift solenoid B	1.0—4.2	
		Shift solenoid C	1.0—4.2	
Shift solenoid D		10.9—26.2		
Shift solenoid E		10.9—26.2		
	Pressure control solenoid	2.4—7.3		

05-50

## TECHNICAL DATA

Item		Engine	
		ZM	FS
Automatic transaxle fluid (ATF)	Type	ATF M-V or equivalent (e.g. Dexron®III)	
	Capacity (Approx. quantity) (L {US qt, Imp qt})	7.2 {7.6, 6.3}	





# SERVICE TOOLS

## 05-60 SERVICE TOOLS

TRANSMISSION/TRANSAXLE SST. . . . 05-60-1

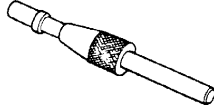
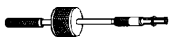
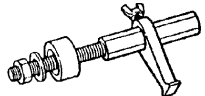
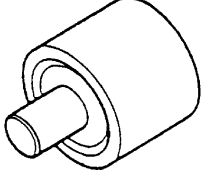
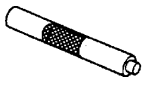
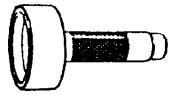
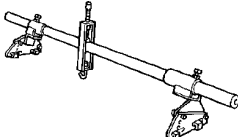
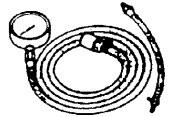
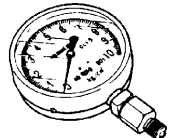
### TRANSMISSION/TRANSAXLE SST

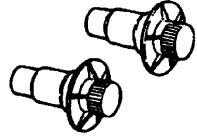
A3U056001024W01

<p>49 0259 770B</p> <p>Flare nut wrench</p> 	<p>49 SE01 310A</p> <p>Clutch disc centering tool</p> 	<p>49 1285 071</p> <p>Bearing puller</p> 
<p>49 E011 1A0</p> <p>Ring gear brake set</p> 	<p>49 F028 202</p> <p>Bush installer</p> 	<p>49 B001 797</p> <p>Handle (Part of 49 B001 795)</p> 
<p>49 B001 795</p> <p>Oil seal installer</p> 	<p>49 E017 5A0</p> <p>Engine support</p> 	<p>49 0378 400C</p> <p>Oil pressure gauge set</p> 
<p>49 B019 901B</p> <p>Oil pressure gauge</p> 	<p>49 H019 002</p> <p>Adapter</p> 	<p>49 G030 455</p> <p>Diff. side gear holder</p> 
<p>49 G030 795</p> <p>Oil seal installer</p> 	<p>418FS475</p> <p>WDS</p> 	<p>—</p>

05-60

# STEERING

**06**  
SECTION

**GENERAL PROCEDURES . . . . . 06-10**  
**ENGINE SPEED SENSING**  
**POWER STEERING . . . . . 06-12**

**TECHNICAL DATA . . . . . 06-50**  
**SERVICE TOOLS . . . . . 06-60**

## 06-10 GENERAL PROCEDURES

**PRECAUTION (STEERING) . . . . . 06-10-1**  
Wheels and Tires  
Removal/Installation . . . . . 06-10-1  
Power Steering Components  
Removal/Installation . . . . . 06-10-1

Connectors  
Disconnection/Connection . . . . . 06-10-1

06-10

### PRECAUTION (STEERING)

A3U061001034W01

#### Wheels and Tires Removal/Installation

1. The removal and installation procedures for the wheels and tires are not mentioned in this section. When a wheel is removed, retighten it to **89—117 N·m {9.0—12.0 kgf·m, 65.1—86.7 ft·lbf}**.

#### Power Steering Components Removal/Installation

1. If any power steering fluid line has been disconnected anytime during the procedure, add ATF M-III or equivalent (e.g. Dexron<sup>®</sup> III), bleed the fluid lines, and inspect for leakage after the procedure has been completed.

#### Connectors Disconnection/Connection

1. Disconnect the negative battery cable before doing any work that requires handling of connectors. Reconnect the negative battery cable only after the work is completed.

# 06-12 ENGINE SPEED SENSING POWER STEERING

**ENGINE SPEED SENSING POWER**

**STEERING LOCATION INDEX** . . . . . 06-12-2

**AIR BLEEDING** . . . . . 06-12-3

**POWER STEERING FLUID**

**INSPECTION** . . . . . 06-12-3

    Fluid Level Inspection . . . . . 06-12-3

    Fluid Leakage Inspection . . . . . 06-12-3

    Fluid Pressure Inspection . . . . . 06-12-4

**STEERING WHEEL AND COLUMN**

**INSPECTION** . . . . . 06-12-5

    Steering Wheel Play Inspection . . . . . 06-12-5

    Steering Wheel Looseness Inspection . 06-12-5

    Steering Wheel Effort Inspection . . . . . 06-12-5

**STEERING WHEEL AND COLUMN**

**REMOVAL/INSTALLATION** . . . . . 06-12-6

    Steering Wheel Removal Note . . . . . 06-12-7

    Steering Lock Mounting Bolts and  
    Bracket Removal Note . . . . . 06-12-7

    Cylinder Outer Component Removal  
    Note . . . . . 06-12-7

    Steering Lock Mounting Bolts and  
    Bracket Installation Note . . . . . 06-12-7

    Steering Shaft Installation Note . . . . . 06-12-8

    Steering Wheel Installation Note . . . . . 06-12-8

**STEERING SHAFT INSPECTION** . . . . . 06-12-8

**STEERING LOCK (ATX MODEL)**

**INSPECTION** . . . . . 06-12-9

**STEERING GEAR AND LINKAGE**

**REMOVAL/INSTALLATION** . . . . . 06-12-9

    Tie-rod End Ball Joint Removal Note . . 06-12-10

    Engine Mount Member Removal Note . 06-12-10

    Bolt (Intermediate Shaft) Removal  
    Note . . . . . 06-12-10

    Steering Gear and Linkage Removal  
    Note . . . . . 06-12-10

    Bolt (Intermediate Shaft) Installation  
    Note . . . . . 06-12-10

**STEERING GEAR AND LINKAGE**

**DISASSEMBLY** . . . . . 06-12-11

    Tie Rod Disassembly Note . . . . . 06-12-12

    Locknut (Adjusting Cover) Disassembly  
    Note . . . . . 06-12-12

    Pinion Shaft and Housing Component  
    Disassembly Note . . . . . 06-12-12

    Pinion Shaft Component Disassembly  
    Note . . . . . 06-12-13

    Snap Ring Disassembly Note . . . . . 06-12-13

    Upper Bearing Disassembly Note . . . . . 06-12-13

    Holder Disassembly Note . . . . . 06-12-13

    Inner Guide Disassembly Note . . . . . 06-12-14

    Mounting Rubber Disassembly Note . . 06-12-14

    Tie-rod End Boot Disassembly Note . . 06-12-15

**STEERING GEAR AND LINKAGE**

**INSPECTION** . . . . . 06-12-15

    Rack Inspection . . . . . 06-12-15

    Tie-rod End Inspection . . . . . 06-12-15

    Tie Rod Inspection . . . . . 06-12-16

**STEERING GEAR AND LINKAGE**

**ASSEMBLY** . . . . . 06-12-17

    Tie-rod End Boot Assembly Note . . . . . 06-12-18

    Mounting Rubber Assembly Note . . . . . 06-12-18

    Oil Seal Assembly Note 1 . . . . . 06-12-19

    Holder Assembly Note . . . . . 06-12-20

    Oil Seal Assembly Note 2 . . . . . 06-12-20

    Upper Bearing Assembly Note . . . . . 06-12-21

    Seal Ring Assembly Note . . . . . 06-12-21

    Adjusting Cover Assembly Note . . . . . 06-12-21

    Hermetic Sealing Inspection . . . . . 06-12-22

**POWER STEERING OIL PUMP**

**REMOVAL/INSTALLATION** . . . . . 06-12-23

**POWER STEERING OIL PUMP (ZM)**

**DISASSEMBLY/ASSEMBLY** . . . . . 06-12-25

    Power Steering Oil Pump Component  
    Disassembly Note . . . . . 06-12-26

    Oil Seal Assembly Note . . . . . 06-12-26

    Vane Assembly Note . . . . . 06-12-26

    Cam Ring Assembly Note . . . . . 06-12-26

    Rear Pump Body Assembly Note . . . . . 06-12-26

**POWER STEERING OIL PUMP (FS)**

**DISASSEMBLY/ASSEMBLY** . . . . . 06-12-27

**06-12**



# ENGINE SPEED SENSING POWER STEERING

## ENGINE SPEED SENSING POWER STEERING LOCATION INDEX

A3U061201036W01

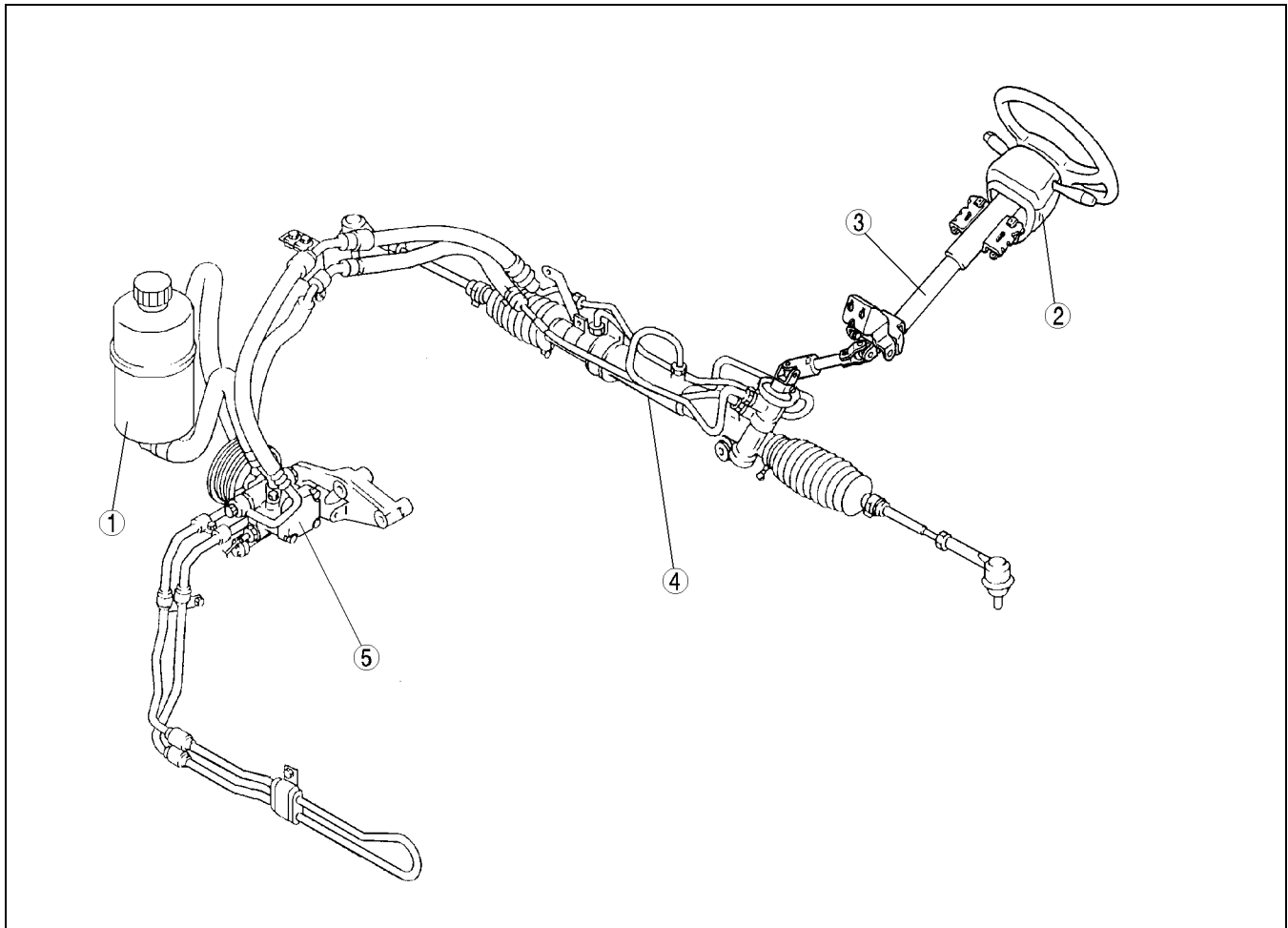

Z3U0612W011

1	Power steering fluid (See 06-12-3 POWER STEERING FLUID INSPECTION)
2	Steering wheel and column (See 06-12-5 STEERING WHEEL AND COLUMN INSPECTION) (See 06-12-6 STEERING WHEEL AND COLUMN REMOVAL/INSTALLATION)
3	Steering shaft (See 06-12-8 STEERING SHAFT INSPECTION)

4	Steering gear and linkage (See 06-12-9 STEERING GEAR AND LINKAGE REMOVAL/INSTALLATION) (See 06-12-11 STEERING GEAR AND LINKAGE DISASSEMBLY) (See 06-12-15 STEERING GEAR AND LINKAGE INSPECTION) (See 06-12-17 STEERING GEAR AND LINKAGE ASSEMBLY)
5	Power steering oil pump (See 06-12-23 POWER STEERING OIL PUMP REMOVAL/INSTALLATION) (See 06-12-25 POWER STEERING OIL PUMP (ZM) DISASSEMBLY/ASSEMBLY) (See 06-12-27 POWER STEERING OIL PUMP (FS) DISASSEMBLY/ASSEMBLY)

# ENGINE SPEED SENSING POWER STEERING

## AIR BLEEDING

A3U061201036W02

1. Inspect the fluid level. (See 06–12–3 Fluid Level Inspection.)
2. Jack up the front of the vehicle and support it on safety stands.
3. Turn the steering wheel fully to the left and right several times with the engine not running.
4. Reinspect the fluid level.
  - If it has dropped, add fluid.
5. Repeat Steps 3 and 4 until the fluid level stabilizes.
6. Lower the vehicle.
7. Start the engine and let it idle.
8. Turn the steering wheel fully to the left and right several times.
9. Verify that the fluid is not foamy and that the fluid level has not dropped.
  - Add fluid as necessary and repeat Steps 8 and 9.

## POWER STEERING FLUID INSPECTION

A3U061232040W01

### Fluid Level Inspection

1. Inspect the power steering fluid level.
  - Add fluid to the specified level as necessary.

### Fluid specification

ATF M-III or equivalent (e.g. Dexron® III)

### Fluid Leakage Inspection

#### Caution

- If the steering wheel is kept in the fully turned position for more than 5 seconds, the fluid temperature will rise excessively and adversely affect the oil pump.

1. Start the engine and let it idle. Turn the steering wheel fully to the left and right to apply fluid pressure.

#### Note

- The points where fluid leakage may occur are indicated in the figure.

2. Inspect for fluid leakage.
  - If fluid leakage is found, replace related pipe or hose.

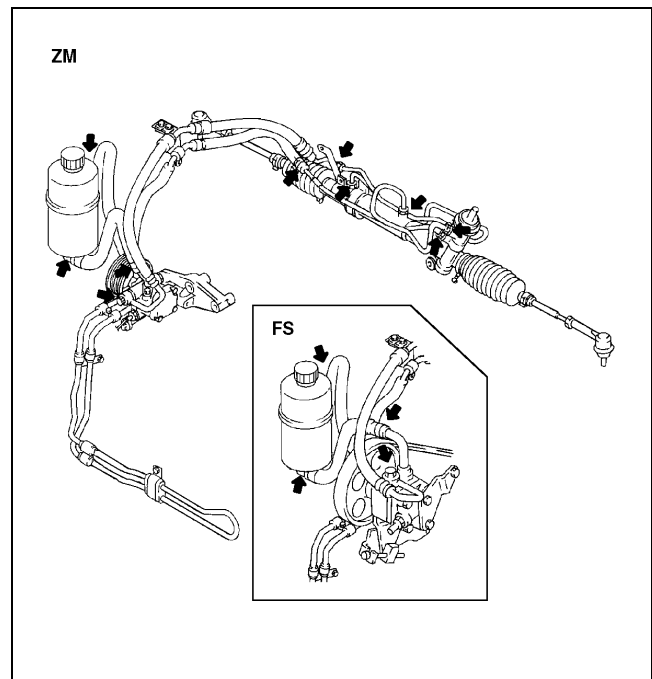

X3U612WBR

# ENGINE SPEED SENSING POWER STEERING

## Fluid Pressure Inspection

1. Assemble the **SSTs** as shown in the figure.
2. Disconnect the pressure pipe from the oil pump, and connect the **SSTs**.

### Tightening torque

30—44 N·m {3.0—4.5 kgf·m, 22—32 ft·lbf}

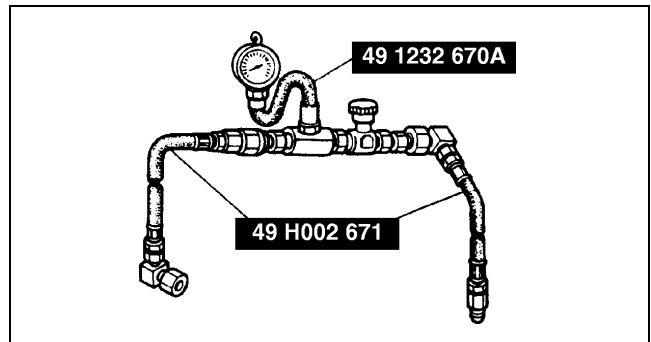

X3U612WA0

3. Bleed the air from the system.
4. Open the gauge valve fully. Start the engine and turn the steering wheel fully left and right to raise the fluid temperature to 50—60 °C {123—140 °F}.

### Caution

- If the valve is left closed for more than 5 seconds, the fluid temperature will rise excessively and adversely affect the oil pump.

5. Close the gauge valve completely. Increase the engine speed to 1,000—1,500 rpm and measure the fluid pressure generated by the oil pump.
  - If the pressure is not within the specification, repair or replace the oil pump component.

### Oil pump fluid pressure

8.34—8.82 MPa {85.0—90.0 kgf/cm<sup>2</sup>, 1,209—1,279 psi}

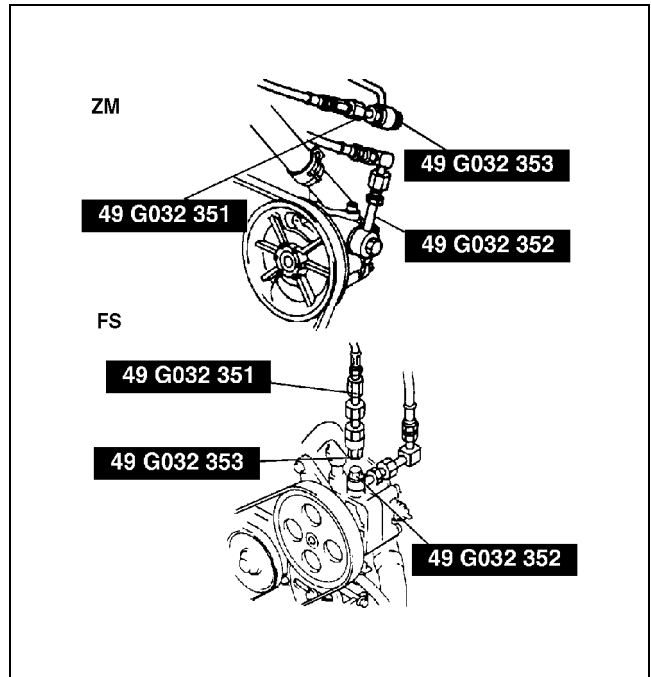

Z3U0612W002

### Caution

- If the steering wheel is kept in the fully turned position for more than 5 seconds, the fluid temperature will rise excessively and adversely affect the oil pump.

6. Open the gauge valve fully and increase the engine speed to 1,000—1,500 rpm.
7. Turn the steering wheel fully to the left and right, then measure the fluid pressure generated at the gear housing.
  - If the pressure is not within the specification, repair or replace the steering gear component.

### Gear housing fluid pressure

8.34—8.82 MPa {85.0—90.0 kgf/cm<sup>2</sup>, 1,209—1,279 psi}

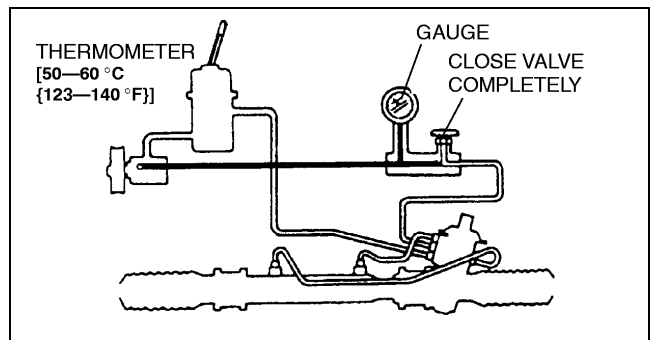

Y3U612WA0

## ENGINE SPEED SENSING POWER STEERING

- Remove the **SSTs**. Install and tighten the pressure pipe to the specified torque.

### Tightening torque

**30—44 N·m {3.0—4.5 kgf·m, 22—32 ft·lbf}**

- Bleed the air from the system.

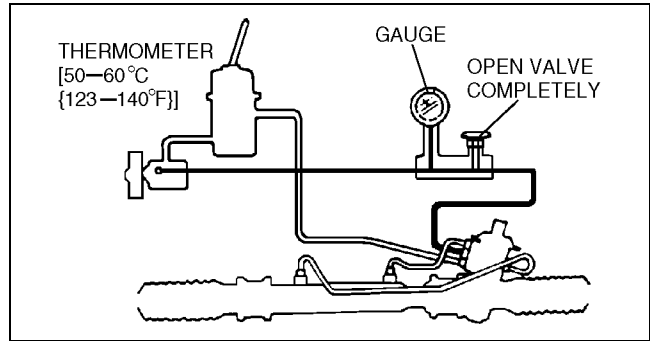

A3U0612W004

## STEERING WHEEL AND COLUMN INSPECTION

A3U061232010W01

### Steering Wheel Play Inspection

- With the wheels in the straight-ahead position, gently turn the steering wheel to the left and right and verify that the play is within the specification.
  - If the play exceeds the specification, either the steering joints are worn or the backlash of the steering gear is excessive. Correct as necessary.

### Play

**0—30 mm {0—1.18 in}**

### Steering Wheel Looseness Inspection

- Move the steering wheel as shown in the figure to inspect for column bearing wear, steering shaft joint play, steering wheel looseness, and column looseness.
  - Repair or replace as necessary.

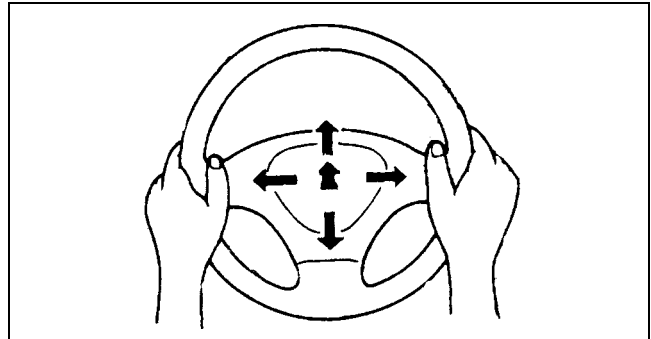

A3U0612W017

### Steering Wheel Effort Inspection

- Inspect the following points:
  - Tire size and tire pressure
  - Fluid level
  - Drive belt deflection
- With the vehicle on a hard, level surface, put the wheels in the straight-ahead position.

### Warning

- See **08-10 DRIVER-SIDE AIR BAG MODULE REMOVAL/INSTALLATION** for removal/installation of the air bag module after inspection.

- Remove the air bag module.
- Start the engine and warm the power steering fluid to **50—60 °C {123—140 °F}**.
- Measure the steering wheel effort using a torque wrench.

- If not within the specification, note the following:
  - Air in system
  - Fluid leakage at hose or connectors
  - Function of oil pump and steering gear

### Steering wheel effort

**7.8 N·m {80 kgf·cm, 69 in·lbf} max.**

### Note

- To determine whether the steering effort is satisfactory or not, perform the inspection on another vehicle of the same model and under the same conditions, and compare the results.

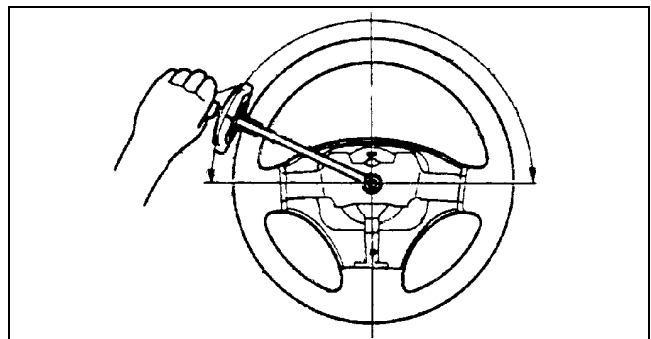

A3U0612W018

# ENGINE SPEED SENSING POWER STEERING

- The steering wheel effort varies with conditions as shown below.
  - Road conditions, such as dry or wet, and asphalt or concrete.
  - Tire conditions, such as brand, wear, and tire pressure.

## STEERING WHEEL AND COLUMN REMOVAL/INSTALLATION

A3U061232010W02

1. Remove in the order indicated in the table.
2. Install in the reverse order of removal.

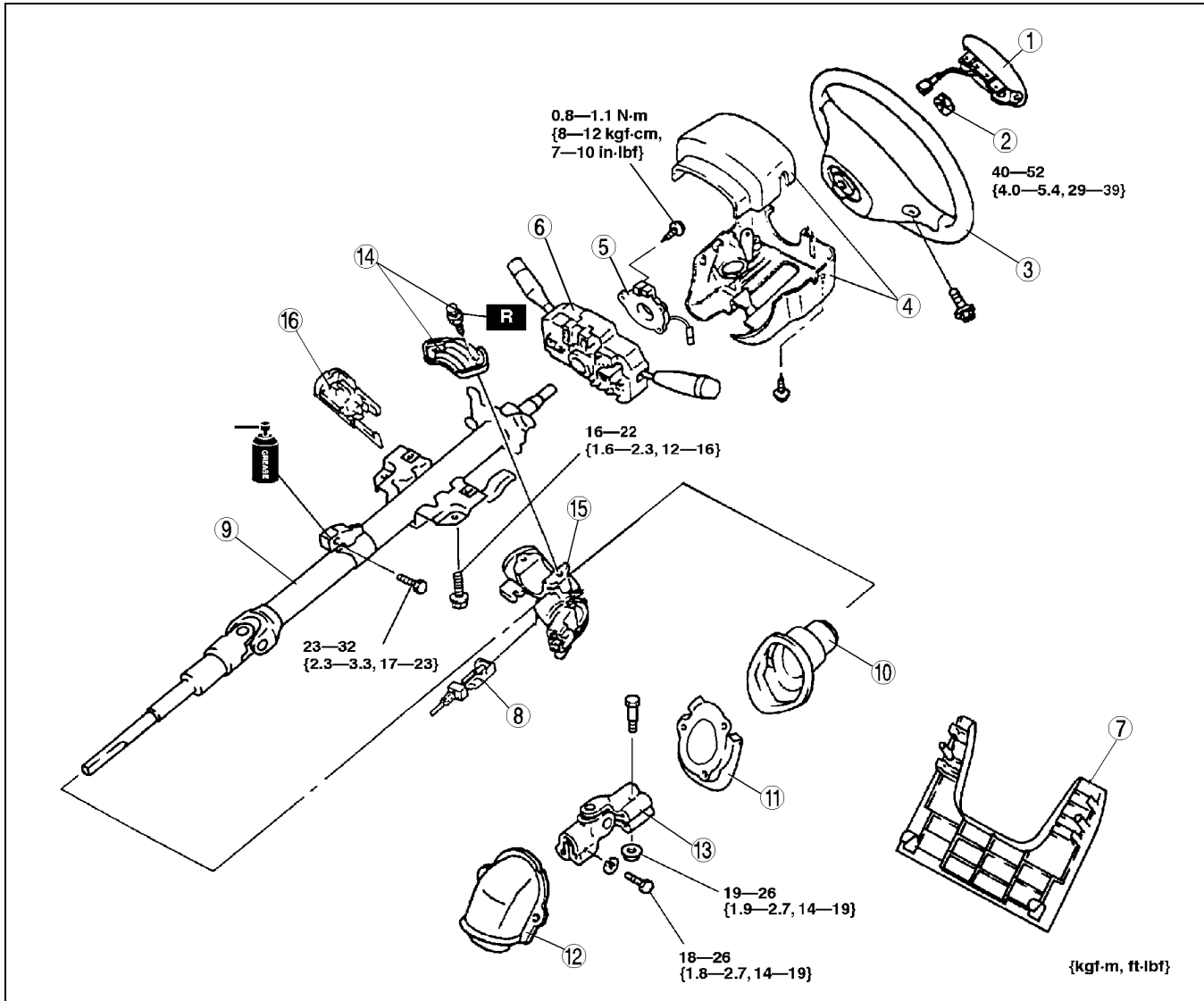

A3U0612W016

1	Air bag module (See 08-10-5 DRIVER-SIDE AIR BAG MODULE REMOVAL/INSTALLATION)
2	Locknut
3	Steering wheel (See 06-12-7 Steering Wheel Removal Note) (See 06-12-8 Steering Wheel Installation Note)
4	Column cover
5	Clock spring (See 08-10-9 CLOCK SPRING REMOVAL/INSTALLATION)
6	Combination switch
7	Lower panel
8	Key interlock cable

9	Steering shaft (See 06-12-8 Steering Shaft Installation Note)
10	Shaft seal
11	Set plate
12	Dust cover
13	Universal joint
14	Steering lock mounting bolts and bracket (See 06-12-7 Steering Lock Mounting Bolts and Bracket Removal Note) (See 06-12-7 Steering Lock Mounting Bolts and Bracket Installation Note)
15	Steering lock component
16	Cylinder outer component (See 06-12-7 Cylinder Outer Component Removal Note)

# ENGINE SPEED SENSING POWER STEERING

## Steering Wheel Removal Note

1. Set the vehicle in the straight-ahead position.
2. Remove the steering wheel using a suitable puller.

### Caution

- Do not try to remove the steering wheel by hitting the shaft with a hammer. The column will collapse.

## Steering Lock Mounting Bolts and Bracket Removal Note

1. Make a groove in the heads of the steering lock mounting bolts using a chisel and a hammer.
2. Remove the bolts using a screwdriver.
3. Disassemble the steering lock component.

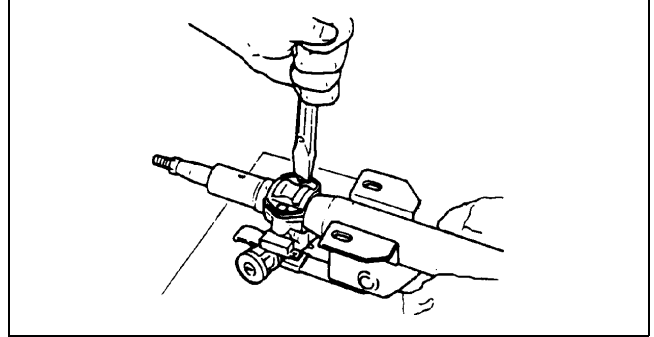

X3U612WA7

06-12

## Cylinder Outer Component Removal Note

### Caution

- When replacing the cylinder outer component, the coil also must be replaced.

1. Set the key in the ACC position.
2. Keep pushing the button and remove the cylinder outer component.

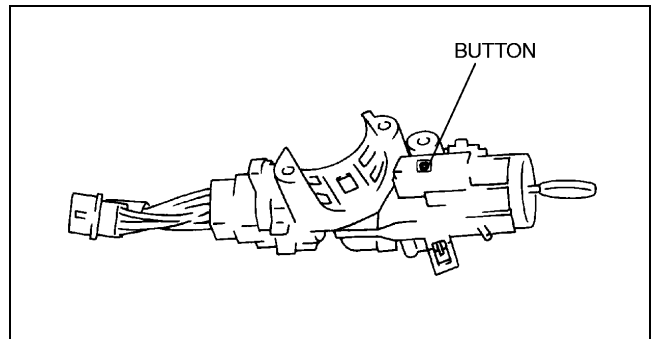

X3U612WA8

## Steering Lock Mounting Bolts and Bracket Installation Note

1. Assemble the steering lock component to the steering shaft.
2. Verify that the lock operates correctly.
3. Install new steering lock mounting bolts.
4. Tighten the bolts until the heads break off.

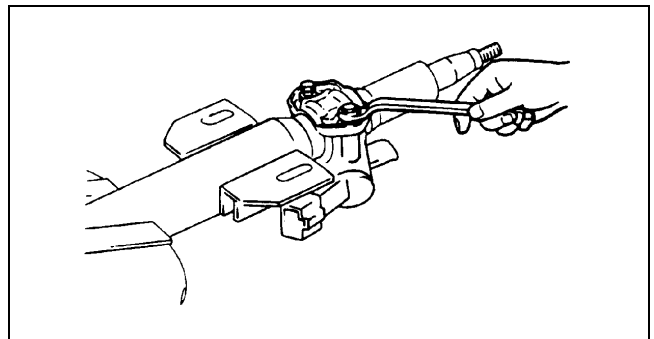

X3U612WA9

# ENGINE SPEED SENSING POWER STEERING

## Steering Shaft Installation Note

### Caution

- Do not apply a shock in the axial direction of the shaft.

1. Tighten bolt A.
2. Tighten bolt C.
3. Tighten bolt B.
4. Release the adjusting lever, and lower the steering shaft to the lowest position.
5. Tighten bolt D.

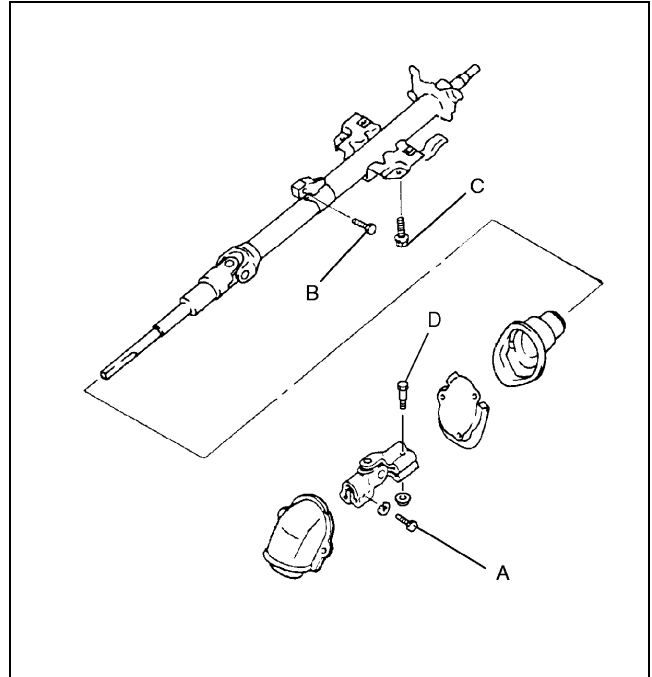

Y3U612WA3

## Steering Wheel Installation Note

1. Set the wheels in the straight-ahead position, and install the steering wheel.

## STEERING SHAFT INSPECTION

A3U061232100W01

1. Inspect the following.
  - (1) Column bearing for damage
  - (2) Steering shaft length
    - Replace the steering shaft component as necessary.

### Length

797.4—800.4 mm {31.40—31.51 in}

2. Tilt operation
  - (1) Verify that the adjusting lever moves smoothly from unlock position to lock position.
  - (2) Verify that the steering shaft is fixed firmly when the adjusting lever is locked.
    - Replace the steering shaft component as necessary.

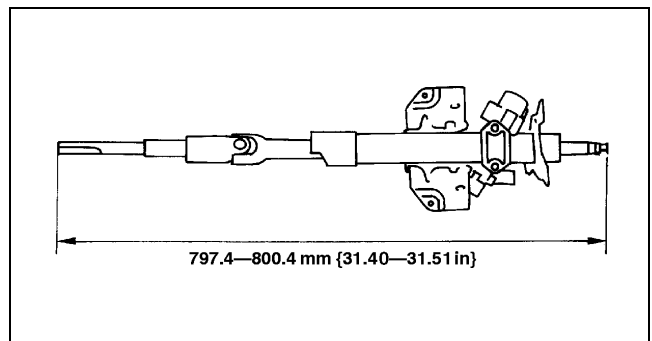

Y3U612WA4

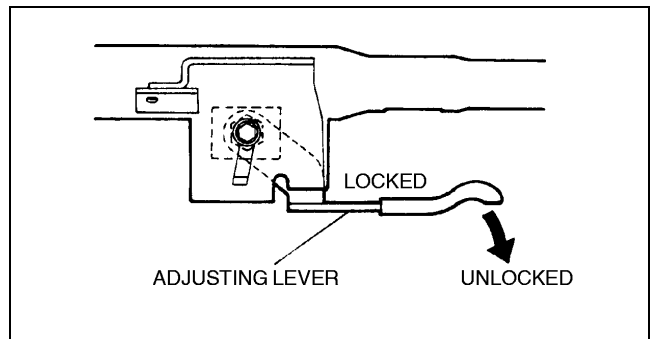

X3U612WAC

# ENGINE SPEED SENSING POWER STEERING

## STEERING LOCK (ATX MODEL) INSPECTION

A3U061275990W01

1. Verify that the cable connector does not move when the key is in the LOCK position and that it moves freely with the key in other positions.
  - Replace the steering lock component as necessary.

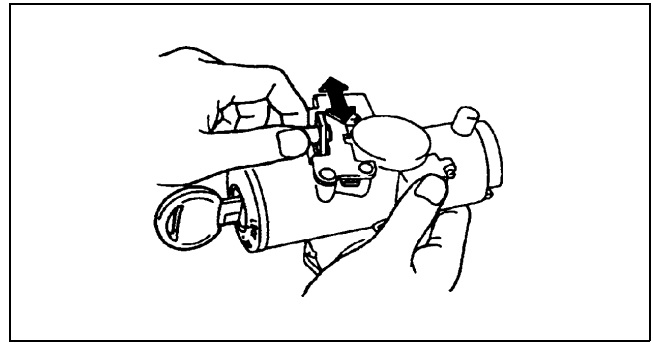

X3U612WAD

## STEERING GEAR AND LINKAGE REMOVAL/INSTALLATION

A3U061232960W01

### Caution

- Performing the following procedures without first removing the ABS wheel-speed sensor may possibly cause an open circuit in the harness if it is pulled by mistake. Before performing the following procedures, remove the ABS wheel-speed sensor (axle side) and fix it to an appropriate place where the sensor will not be pulled by mistake while servicing the vehicle.

06-12

1. Remove in the order indicated in the table.
2. Install in the reverse order of removal.
3. After installation, inspect the toe-in. (See 02-11-1 FRONT WHEEL ALIGNMENT.)

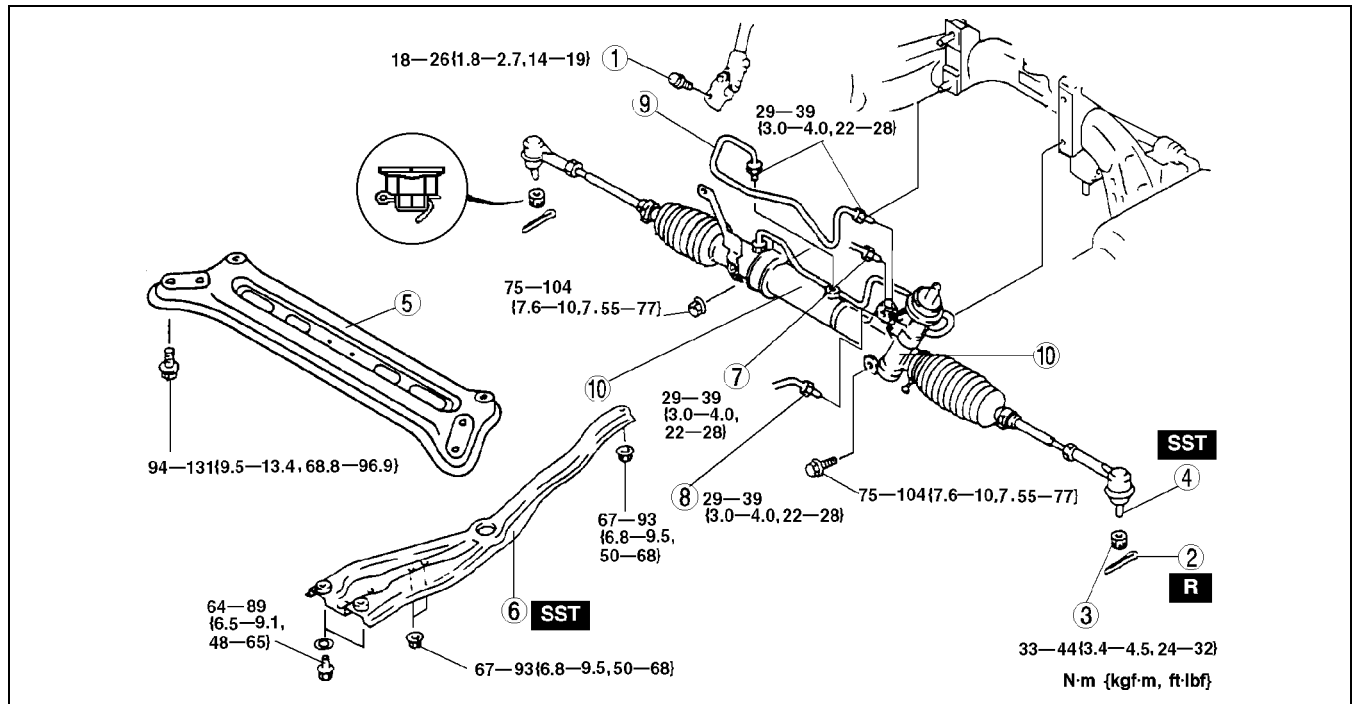

A3U0612W012

1	Bolt (intermediate shaft) (See 06-12-10 Bolt (Intermediate Shaft) Removal Note) (See 06-12-10 Bolt (Intermediate Shaft) Installation Note)
2	Cotter pin
3	Nut
4	Tie-rod end ball joint (See 06-12-10 Tie-rod End Ball Joint Removal Note)

5	Transverse member (ZM (ATX), FS)
6	Engine mount member (See 06-12-10 Engine Mount Member Removal Note)
7	Pressure pipe
8	Return pipe and clamp
9	Oil pipe
10	Steering gear and linkage (See 06-12-10 Steering Gear and Linkage Removal Note)



## ENGINE SPEED SENSING POWER STEERING

### Tie-rod End Ball Joint Removal Note

1. Remove the tie rod nut.
2. Separate the tie-rod end from the steering knuckle using the **SSTs**.

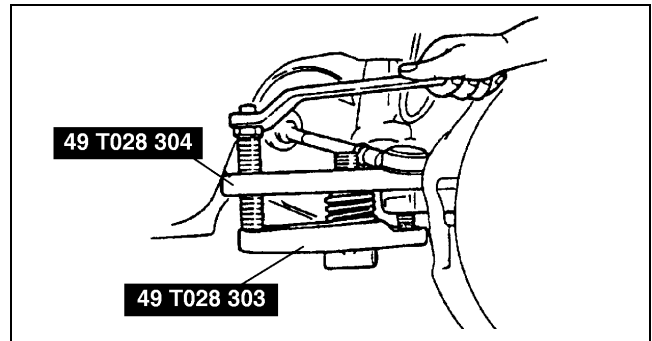

X3U612WAF

### Engine Mount Member Removal Note

1. Set the **SSTs** as shown in the figure.
2. Remove the engine mount member.

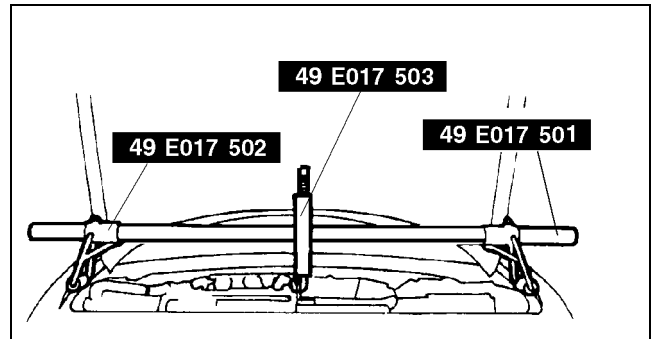

Z3U0612W004

### Bolt (Intermediate Shaft) Removal Note

1. Mark the pinion shaft and gear housing for proper installation.

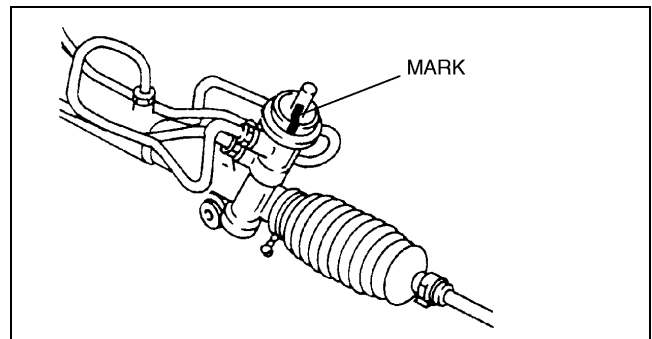

Y3U612WA8

### Steering Gear and Linkage Removal Note

1. Remove the steering gear and linkage by pulling it from the right side.

### Bolt (Intermediate Shaft) Installation Note

1. Align the marks and install the intermediate shaft and bolt.

# ENGINE SPEED SENSING POWER STEERING

## STEERING GEAR AND LINKAGE DISASSEMBLY

A3U061232960W02

1. Disassemble in the order indicated in the table.

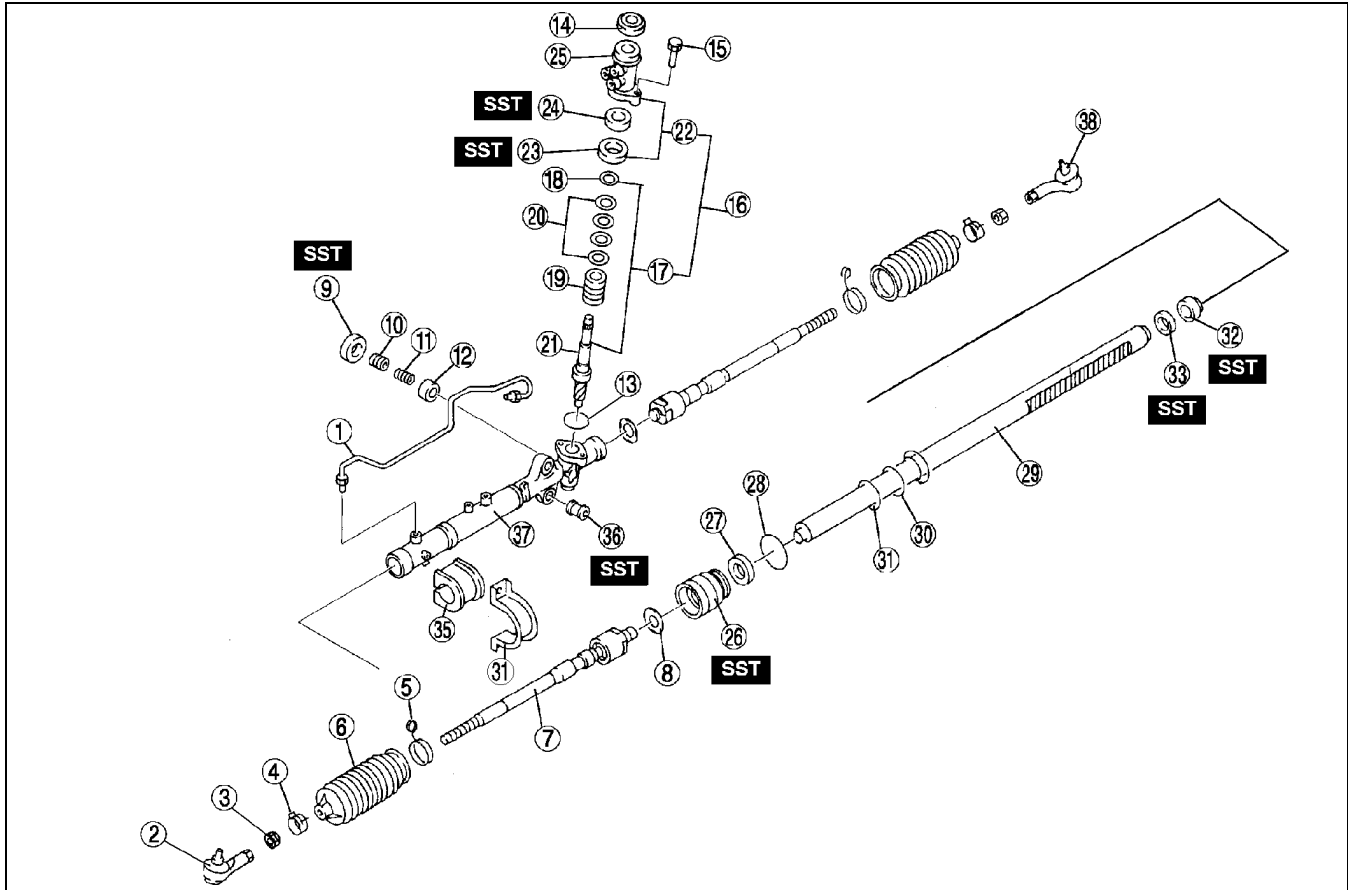

06-12

Z3U0612W013

1	Oil pipe
2	Tie-rod end
3	Locknut (Tie-rod end)
4	Boot band
5	Boot wire
6	Boot
7	Tie rod (See 06-12-12 Tie Rod Disassembly Note)
8	Washer
9	Locknut (Adjusting cover) (See 06-12-12 Locknut (Adjusting Cover) Disassembly Note)
10	Adjusting cover
11	Yoke spring
12	Support yoke
13	O-ring
14	Dust cover
15	Socket bolt
16	Pinion shaft and housing component (See 06-12-12 Pinion Shaft and Housing Component Disassembly Note)
17	Pinion shaft component (See 06-12-13 Pinion Shaft Component Disassembly Note)
18	Snap ring (See 06-12-13 Snap Ring Disassembly Note)
19	Control valve component

20	Seal ring
21	Pinion shaft
22	Valve housing component
23	Upper bearing (See 06-12-13 Upper Bearing Disassembly Note)
24	Oil seal
25	Valve housing
26	Holder (See 06-12-13 Holder Disassembly Note)
27	U-gasket
28	O-ring
29	Steering rack
30	Seal ring
31	O-ring
32	Inner guide (See 06-12-14 Inner Guide Disassembly Note)
33	Oil seal
34	Mounting bracket
35	Mount
36	Mounting rubber (See 06-12-14 Mounting Rubber Disassembly Note)
37	Gear housing
38	Tie-rod end boot (See 06-12-15 Tie-rod End Boot Disassembly Note)

## ENGINE SPEED SENSING POWER STEERING

### Tie Rod Disassembly Note

1. Unclamp the washer.
2. Remove the tie-rod.

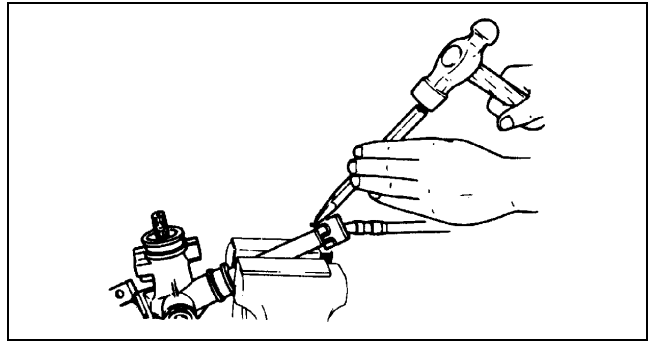

X3U612WAK

### Locknut (Adjusting Cover) Disassembly Note

1. Remove the locknut using the SST.

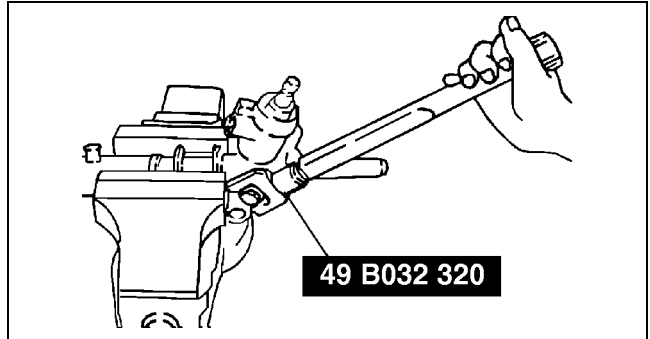

A3U0612W009

### Pinion Shaft and Housing Component Disassembly Note

1. Remove the socket bolts (2 points) which fix the pinion shaft and housing.

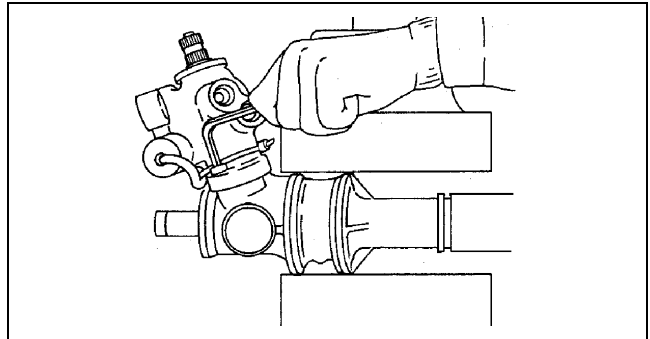

X3U612WAM

2. Hold the pinion shaft as shown, and pull the pinion shaft out and housing component.

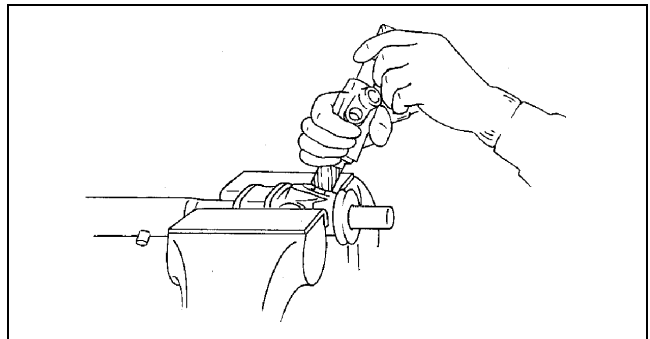

X3U612WAN

## ENGINE SPEED SENSING POWER STEERING

### Pinion Shaft Component Disassembly Note

1. Push the pinion shaft component out from the valve housing as shown.

#### Note

- If the pinion shaft does not come out easily, remove it using a press.

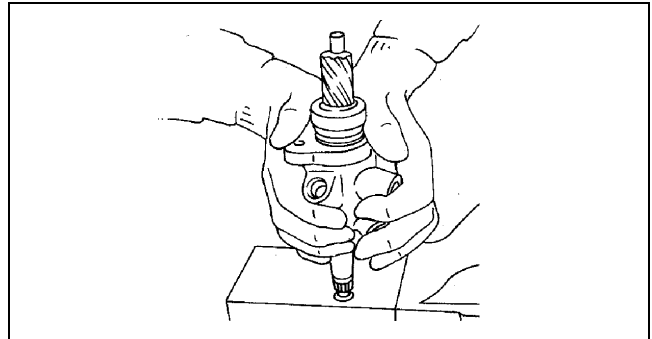

X3U612WAP

### Snap Ring Disassembly Note

1. Carefully remove the snap ring without damaging the pinion shaft component.

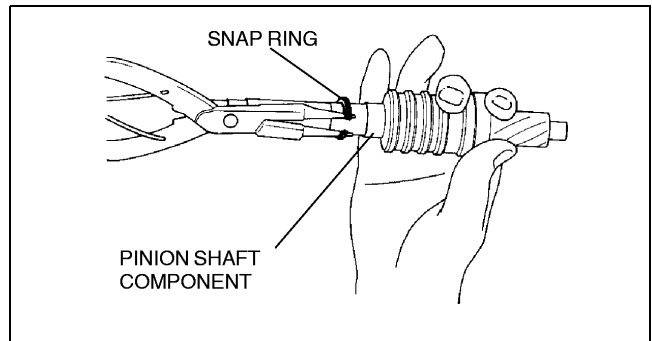

X3U612WQAQ

06-12

### Upper Bearing Disassembly Note

1. Set the **SST** as shown.
2. Using a press, remove the oil seal and upper bearing without applying pressure to the edge of the valve housing.

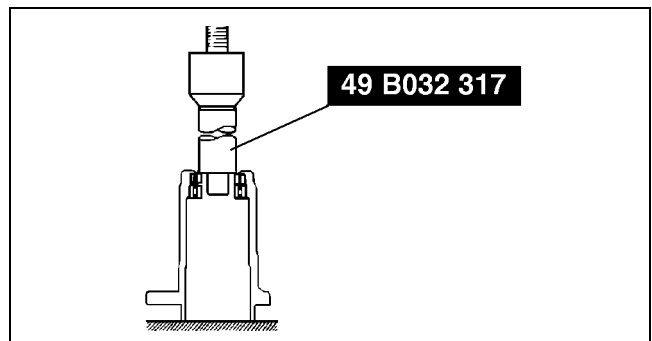

A3U0612W005

### Holder Disassembly Note

1. Cut away the staked area using a drill.

#### Caution

- Carefully pull the holder out without damaging the U-gasket.

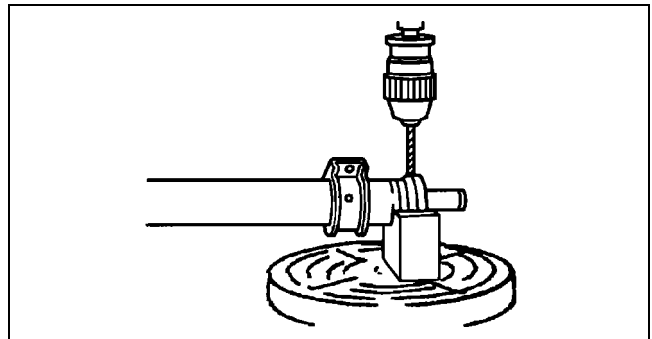

A3U0612W010

## ENGINE SPEED SENSING POWER STEERING

2. Disassemble the holder using the **SST**.

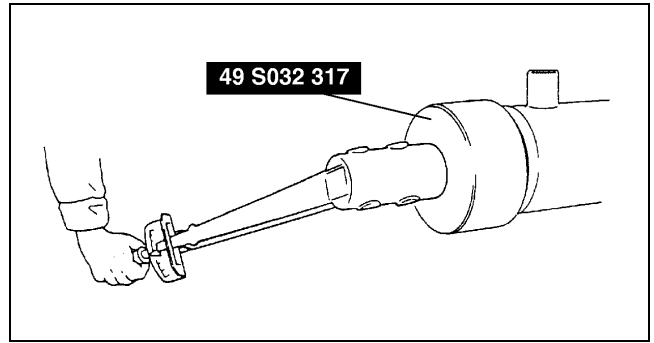

X3U612WAT

### Inner Guide Disassembly Note

1. Set the **SSTs** into the valve side.
2. Install the **SST** to the gear housing.
3. Press the oil seal and inner guide out.

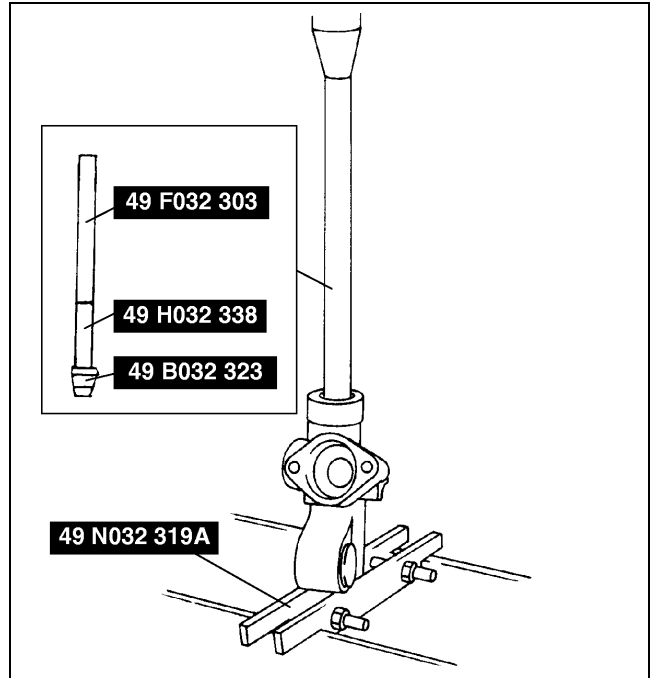

X3U612WAU

### Mounting Rubber Disassembly Note

1. Press the mounting rubber out from the gear housing using the **SSTs** and a press.

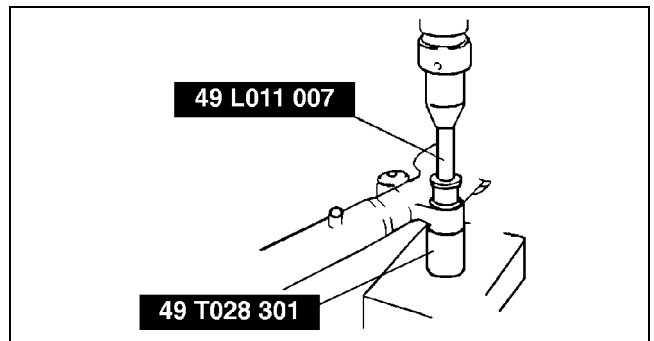

A3U0612W006

# ENGINE SPEED SENSING POWER STEERING

## Tie-rod End Boot Disassembly Note

1. Secure the tie-rod end in a vise.
2. Place a chisel against the boot and hold it at the angle shown.
3. Remove the boot by tapping it with a hammer.

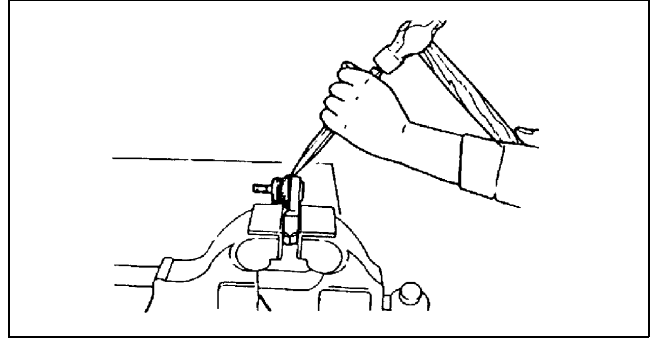

X3U612WAW

## STEERING GEAR AND LINKAGE INSPECTION

### Rack Inspection

1. Inspect the rack for cracking, damage, and tooth wear.
  - Replace it as necessary.
2. Measure the runout of the rack.
  - If not within the specification, replace the rack.

A3U061232960W03

### Runout

Near point A: 0.15 mm {0.0059 in} max.

Near point B: 0.20 mm {0.0079 in} max.

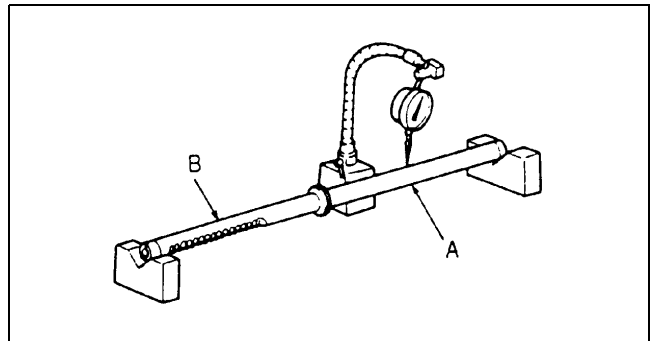

X3U612WAX

06-12

### Tie-rod End Inspection

1. Inspect the tie-rod end for damage and boot cracks.
  - Replace it as necessary.
2. Inspect the ball joint for looseness.
  - Replace the tie-rod end as necessary.
3. Rotate the ball joint **5 times**.
4. Measure the rotation torque of the ball joint using the SST and a pull scale.
  - If not within the specification, replace the tie-rod end.

### Rotation torque

0.35—2.54 N·m {3.5—26.0 kgf·cm, 3.1—22.5 in·lbf}

### Pull scale reading

3.5—25.4 N {0.35—2.60 kgf, 0.78—5.72 lbf}

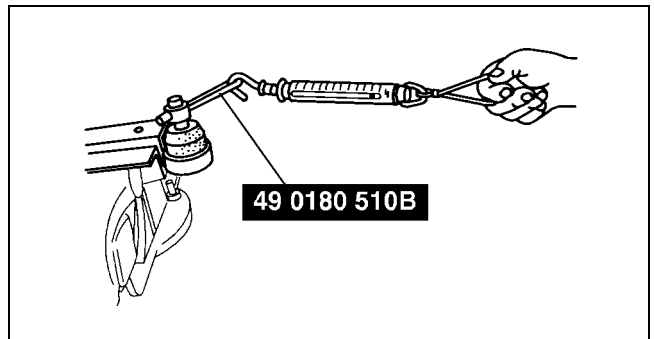

A3U0612W015

## ENGINE SPEED SENSING POWER STEERING

### Tie Rod Inspection

1. Inspect the tie rod for bending and damage.
  - Replace it as necessary.
2. Inspect the ball joint for looseness.
  - Replace the tie rod as necessary.
3. Swing the tie-rod **5 times**.
4. Measure the swinging torque using a pull scale.
  - If not within the specification, replace the tie rod.

### Swinging torque

0.1—3.8 N·m {1—39 kgf·cm, 1—33 in·lbf}

### Pull scale reading

0.6—24.5 N·m {0.06—2.50 kgf, 0.14—5.50 lbf}

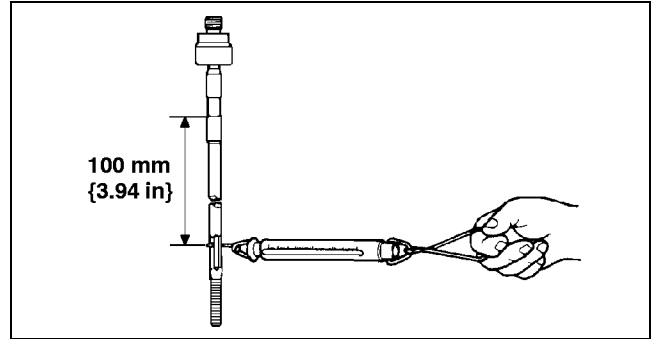

A3U0612W003

# ENGINE SPEED SENSING POWER STEERING

## STEERING GEAR AND LINKAGE ASSEMBLY

A3U061232960W04

1. Assemble in the order indicated in the table.

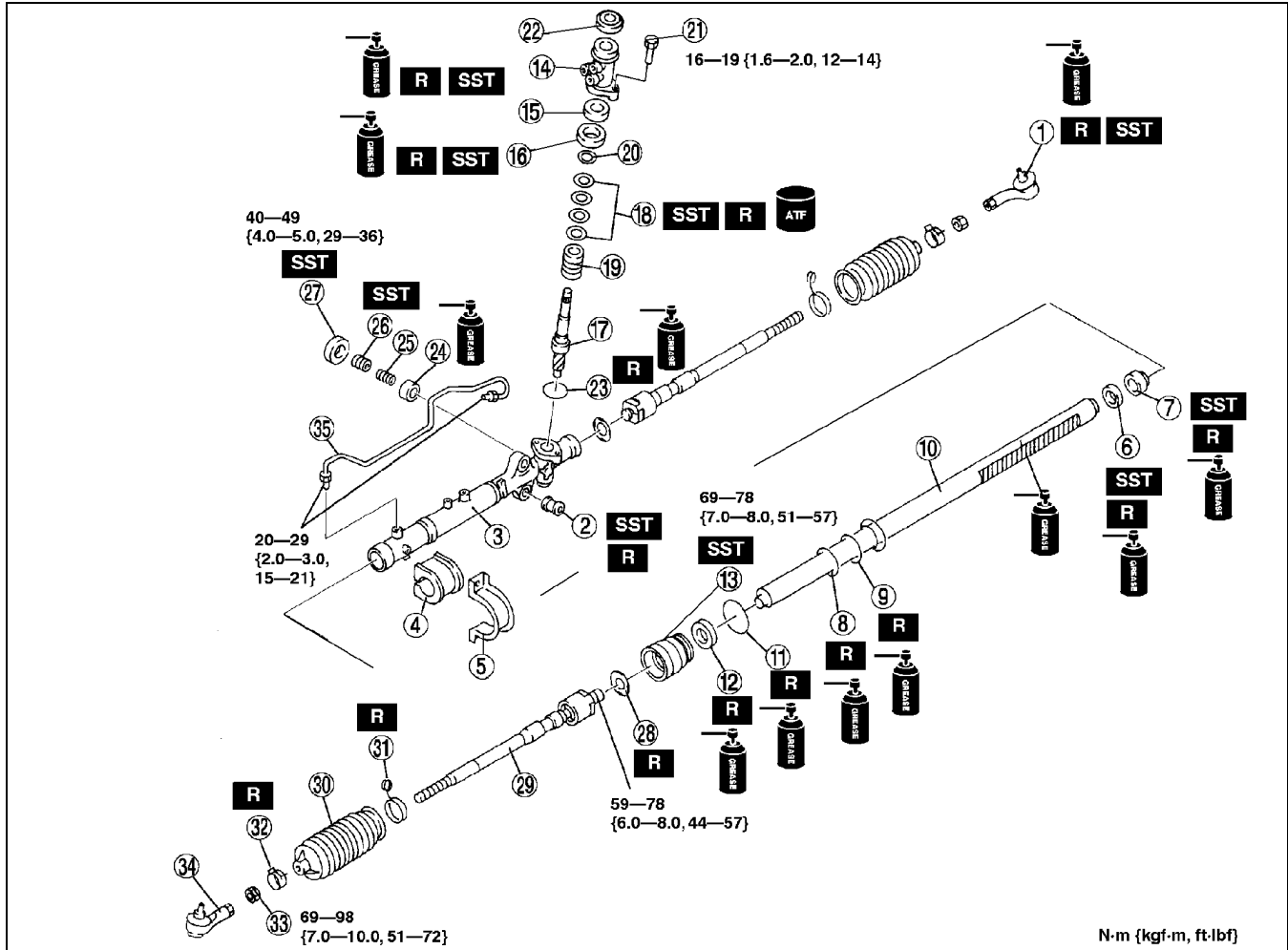

06-12

Z3U0612W014

1	Tie-rod end boot (See 06-12-18 Tie-rod End Boot Assembly Note)
2	Mounting rubber (See 06-12-18 Mounting Rubber Assembly Note)
3	Gear housing
4	Mount
5	Mounting bracket
6	Oil seal (See 06-12-19 Oil Seal Assembly Note 1)
7	Inner guide
8	O-ring
9	Seal ring
10	Steering rack
11	O-ring
12	U-gasket
13	Holder (See 06-12-20 Holder Assembly Note)
14	Valve housing
15	Oil seal (See 06-12-20 Oil Seal Assembly Note 2)
16	Upper bearing (See 06-12-21 Upper Bearing Assembly Note)

17	Pinion shaft
18	Seal ring (See 06-12-21 Seal Ring Assembly Note)
19	Control valve
20	Snap ring
21	Socket bolt
22	Dust cover
23	O-ring
24	Support yoke
25	Yoke spring
26	Adjusting cover (See 06-12-21 Adjusting Cover Assembly Note)
27	Locknut (Adjusting cover)
28	Washer
29	Tie-rod
30	Boot
31	Boot wire
32	Boot band
33	Locknut (Tie-rod End)
34	Tie-rod End
35	Oil pipe



# ENGINE SPEED SENSING POWER STEERING

## Tie-rod End Boot Assembly Note

1. Wipe the grease off the ball joint.
2. Put a small amount of lithium-based grease into a new dust boot.
3. Install the dust boot onto the tie-rod end using the **SST** and a press.
4. Wipe away any excessive grease.

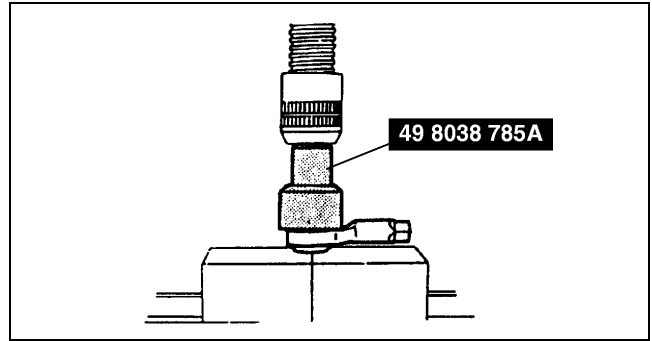

X3U612WB1

## Mounting Rubber Assembly Note

1. Apply soapy water to the rubber part of the mounting rubber.
2. Press the mounting rubber until the mounting rubber end comes out completely from the gear housing using the **SSTs** and a press.

### Note

- Mounting rubber end and steel plate shall be aligned.

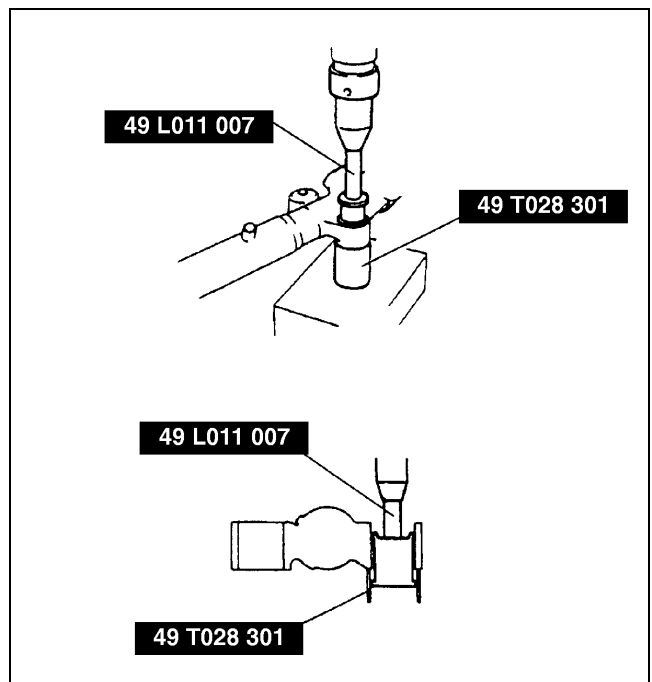

X3U612WB2

3. Reverse the gear housing, then press the mounting rubber until the mounting rubber end comes completely out the other side.

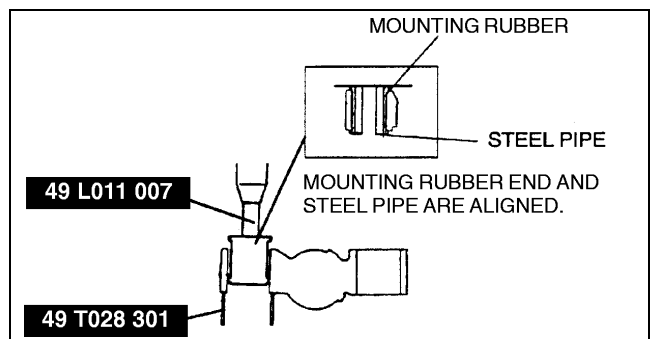

X3U612WB3

## ENGINE SPEED SENSING POWER STEERING

### Oil Seal Assembly Note 1

1. Install a new O-ring and new seal ring to the rack piston.
2. After installing the seal ring, seat it properly at the piston circumference.
3. Install a new oil seal to the **SST** (49 B032 319) using the **SST** (49 B032 318).
4. Remove the **SST** (49 B032 318).

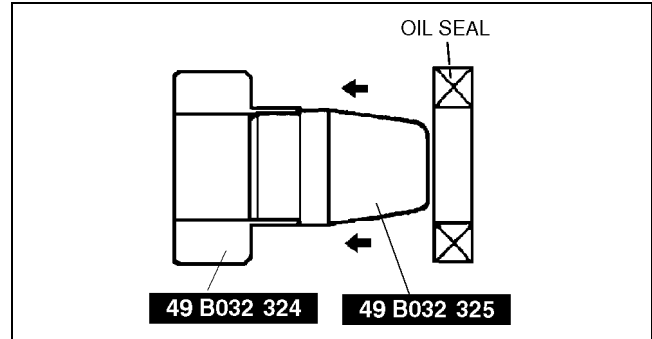

5. Using the **SST**, place the oil seal at the edge of the steering rack's piston and remove the **SST**.
6. Install a new inner guide to the steering rack.

### Caution

- When pressing in, do not apply a load pressure of more than 39.2 MPa {400 kgf/cm<sup>2</sup>, 5,690 psi}. Doing so will damage the oil seal and inner guide.

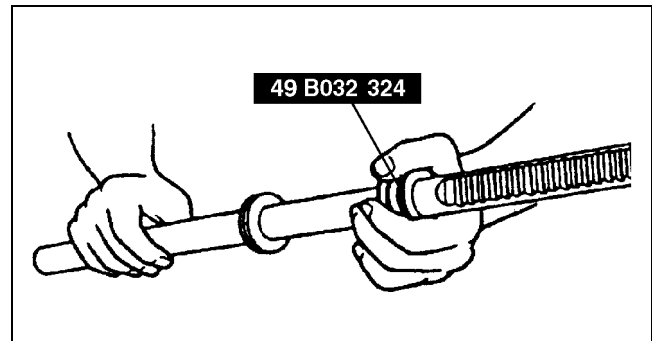

7. After installing the steering rack to the gear housing, press the oil seal and inner guide using the **SST** until the force required suddenly increases.

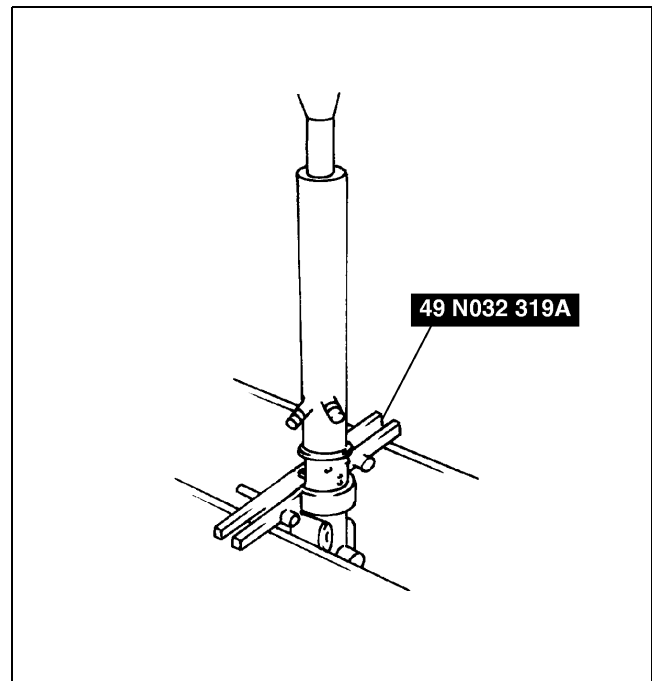

# ENGINE SPEED SENSING POWER STEERING

## Holder Assembly Note

1. Apply grease to the U-gasket and O-ring.
2. Assemble the U-gasket and O-ring into the holder.
3. Assemble the **SST** to the steering rack.

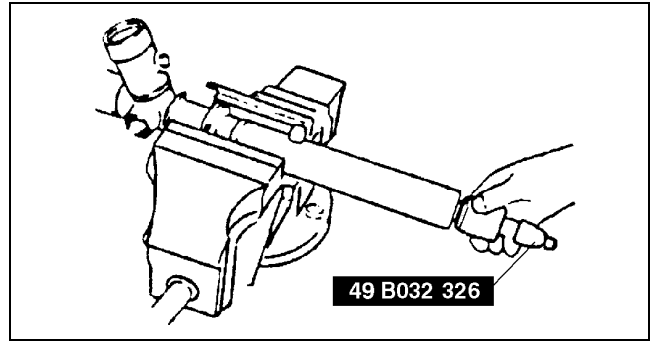

4. Assemble the holder using the **SST**.

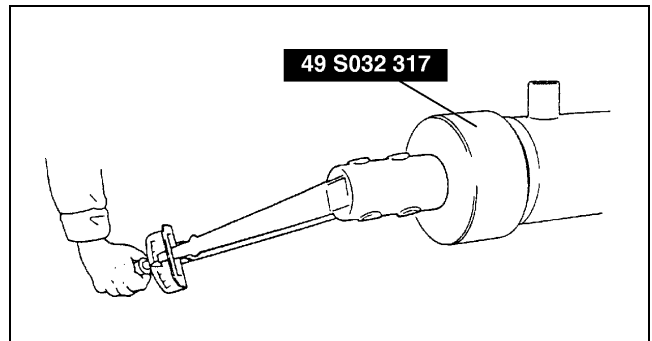

5. Stake the holder to the cylinder using a punch.

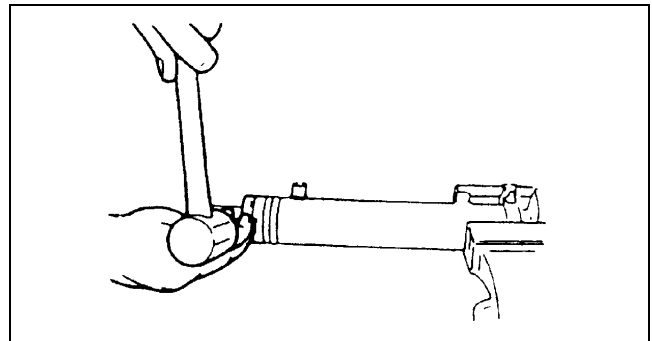

## Oil Seal Assembly Note 2

1. Apply grease to a new oil seal.
2. Press in the new oil seal using the **SSTs**.

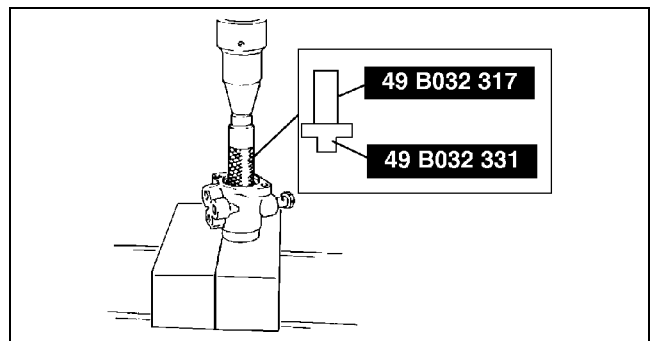

# ENGINE SPEED SENSING POWER STEERING

## Upper Bearing Assembly Note

1. Apply grease to a new upper bearing.
2. Press in the new oil seal using the **SSTs**.

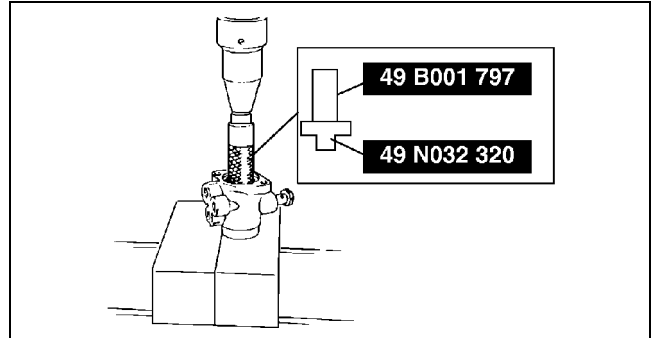

A3U0612W013

## Seal Ring Assembly Note

1. Install a new seal ring to the valve part of the pinion shaft using the **SST**.
2. After installing it, seat it properly using the **SST**.
3. Install the snap ring.

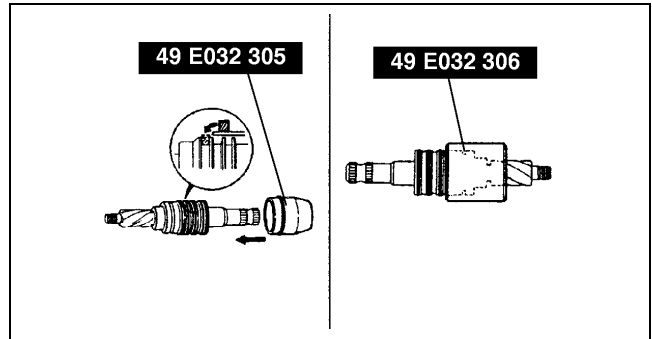

X3U612WBC

06-12

## Adjusting Cover Assembly Note

1. Set the rack to the center position.
2. Tighten the adjusting cover to **20 N·m {2.0 kgf·m, 14 ft·lbf} 3 times**, then return it **42°** using the **SST**.
3. Apply sealant to the threads of the locknut.
4. Attach the locknut.

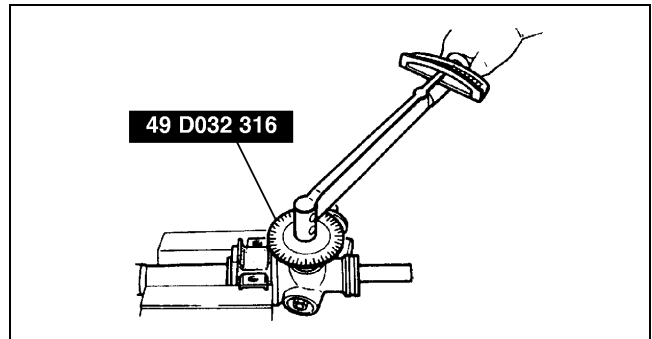

X3U612WBD

5. Measure the pinion torque using the SST and a pull scale.
  - If not as specified, repeat Step 2 through 5.

## Standard

Center of rack  $\pm 90^\circ$  0.8—1.1 N·m {8—11 kgf·cm, 7—9 in·lbf} [Pull scale reading 8—11 N {0.8—1.1 kgf, 1.7—2.4 lbf}]

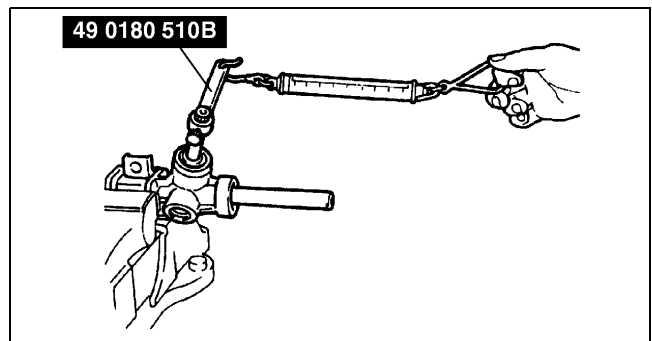

X3U612WBE

## ENGINE SPEED SENSING POWER STEERING

6. Install the locknut using the SST.

### Tightening torque

40—49 N·m {4.0—5.0 kgf·m, 29—36 ft·lbf}

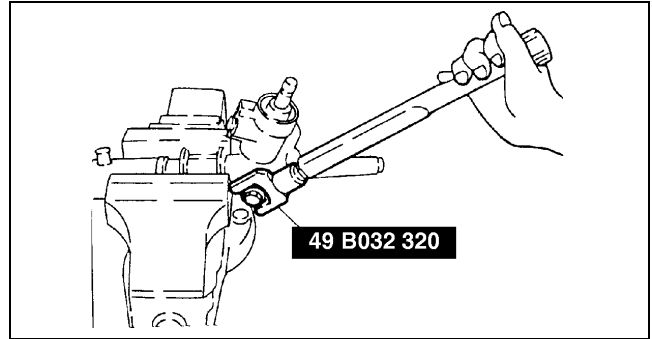

X3U612WBF

### Hermetic Sealing Inspection

1. Connect the SSTs to the power cylinder section of the gear housing.
2. Apply **53.3 kPa {400 mmHg, 15.7 inHg}** vacuum with a vacuum pump and verify that it is held for at least **30 seconds**.
  - If the vacuum is not held, replace the oil seal.

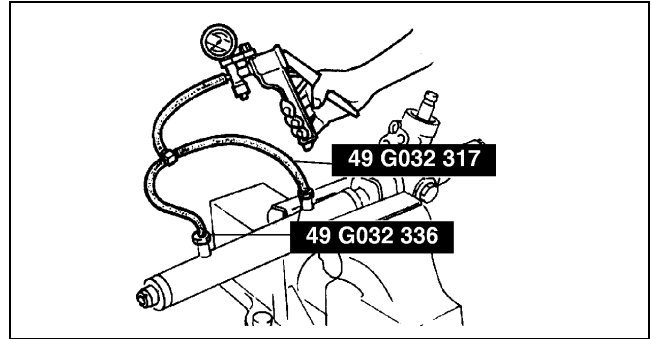

X3U612WBG

# ENGINE SPEED SENSING POWER STEERING

## POWER STEERING OIL PUMP REMOVAL/INSTALLATION

A3U061232650W01

1. Remove in the order indicated in the table.
2. Install in the reverse order of removal.
3. Adjust the drive belt. (See 01-10A-4 DRIVE BELT ADJUSTMENT [ZM].) (See 01-10B-4 DRIVE BELT ADJUSTMENT [FS].)

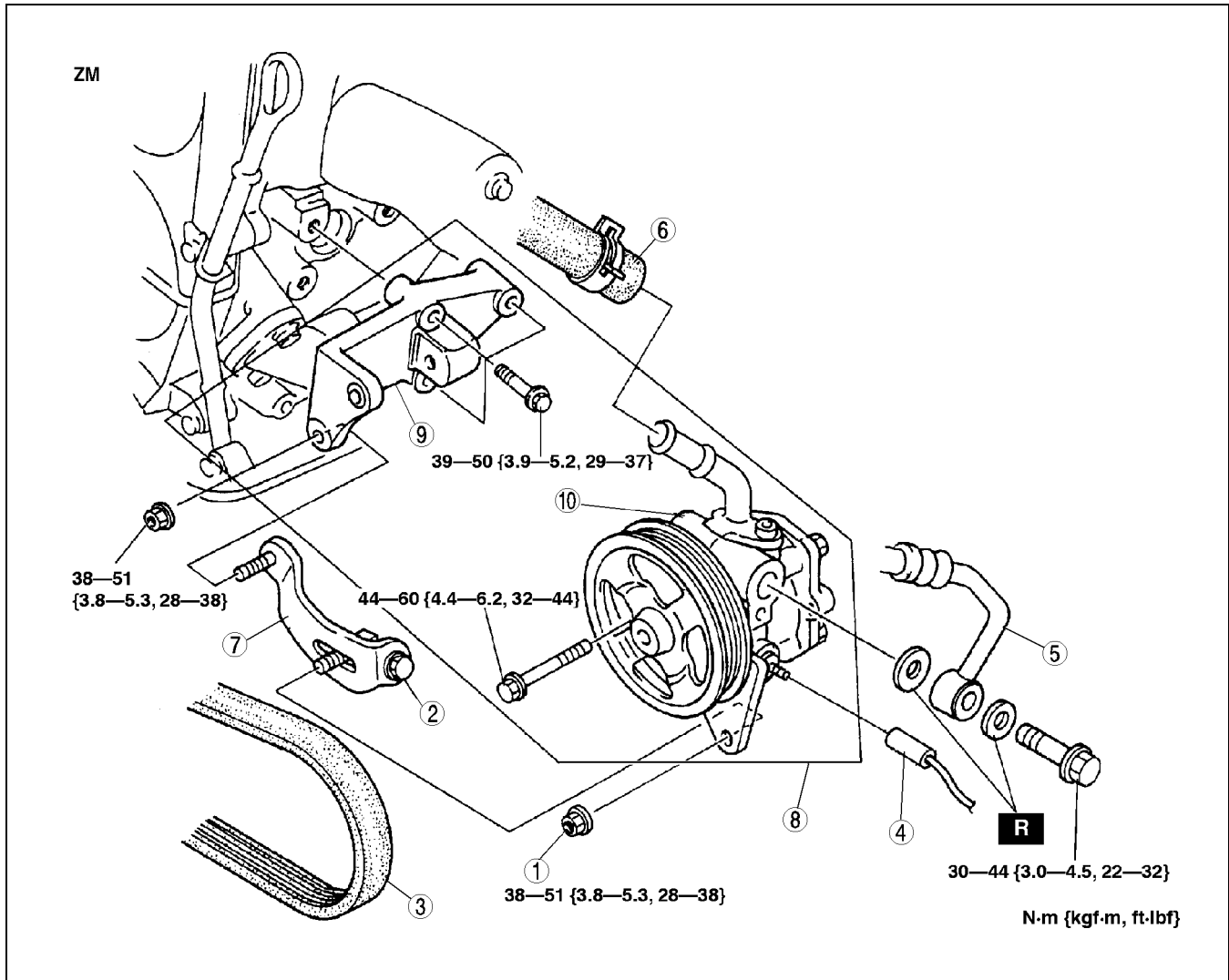

06-12

Z3U0612W008

1	Locknut
2	Adjusting bolt
3	Drive belt
4	Pressure switch connector
5	Pressure pipe

6	Return hose
7	Bracket
8	Power steering oil pump, bracket
9	Oil pump bracket
10	Power steering oil pump

# ENGINE SPEED SENSING POWER STEERING

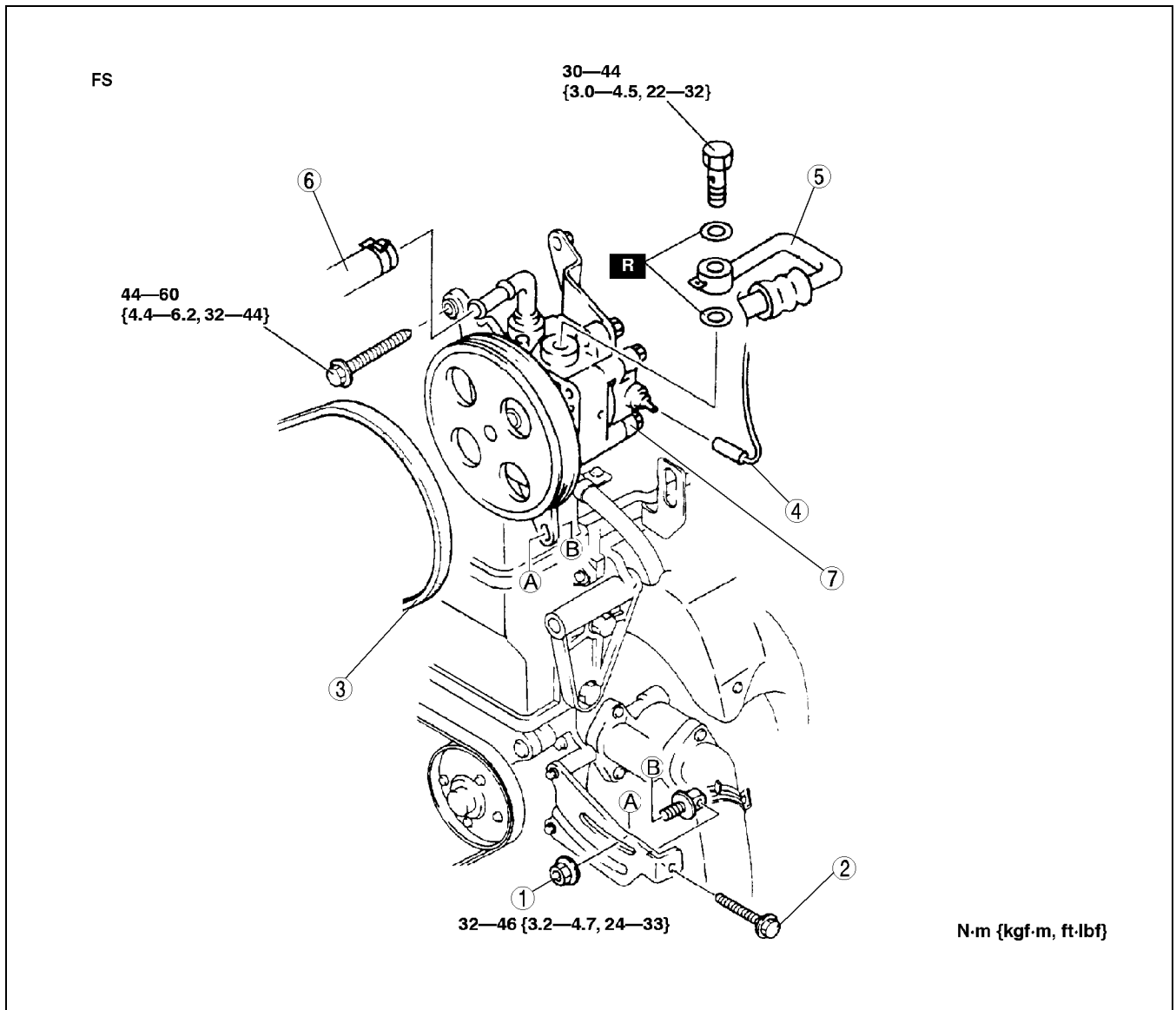

Z3U0612W009

1	Locknut
2	Adjusting bolt
3	Drive belt
4	Pressure switch connector

5	Pressure pipe
6	Return hose
7	Power steering oil pump and bracket

# ENGINE SPEED SENSING POWER STEERING

## POWER STEERING OIL PUMP (ZM) DISASSEMBLY/ASSEMBLY

A3U061232650W02

### Note

- The following procedure is for replacement of the O-ring and oil seal only. Replace the pump component if other repairs are necessary.

- Disassemble in the order indicated in the table.
- Assemble in the reverse order of disassembly.

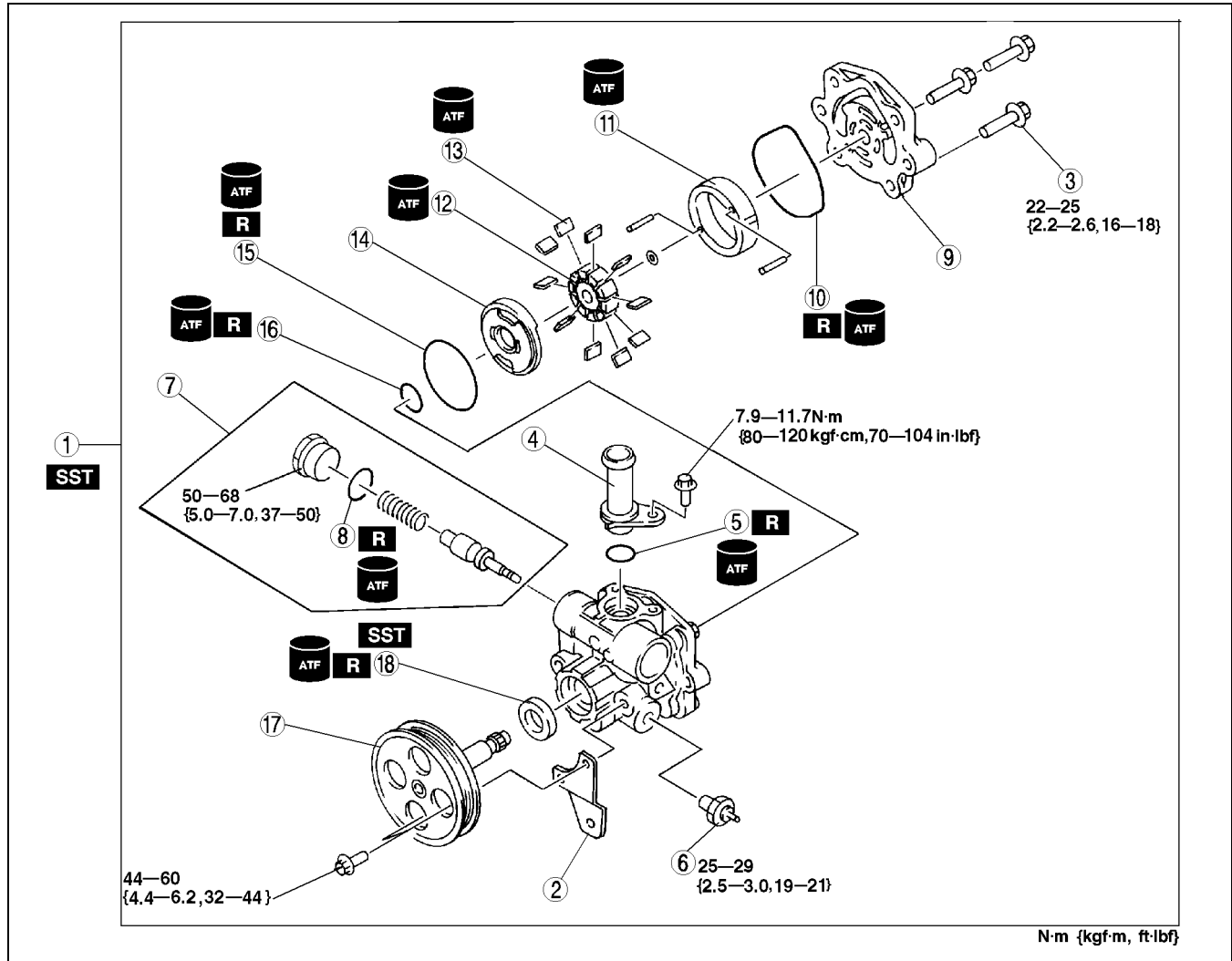

A3U0612W002

1	Power steering oil pump component (See 06-12-26 Power Steering Oil Pump Component Disassembly Note)
2	Front bracket
3	Bolt
4	Suction pipe
5	O-ring
6	Pressure switch component
7	Connector component
8	O-ring
9	Rear pump body (See 06-12-26 Rear Pump Body Assembly Note)

10	O-ring
11	Cam ring (See 06-12-26 Cam Ring Assembly Note)
12	Rotor
13	Vane (See 06-12-26 Vane Assembly Note)
14	Side plate
15	O-ring
16	O-ring
17	Shaft component
18	Oil seal (See 06-12-26 Oil Seal Assembly Note)



# ENGINE SPEED SENSING POWER STEERING

## Power Steering Oil Pump Component Disassembly Note

### Caution

- Use the SST to prevent damage to the pump when securing it in a vise.

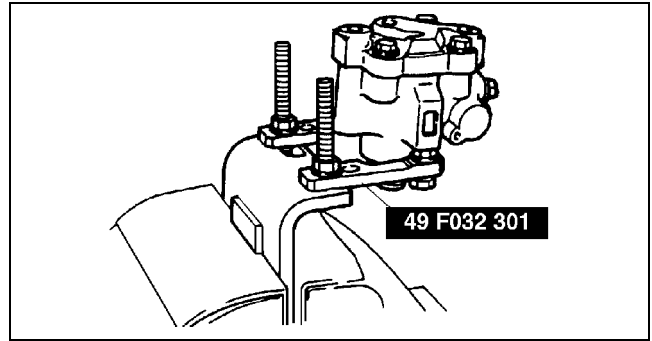

A3U0612W001

## Oil Seal Assembly Note

1. Assemble the oil seal using the SST and a hammer.

### Caution

- The pump body should be positioned evenly.

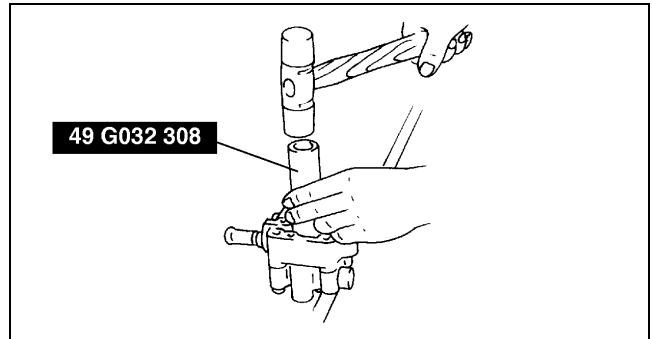

X3U612WBM

## Vane Assembly Note

1. Place the vanes in the rotor with the rounded edges contacting the cam.

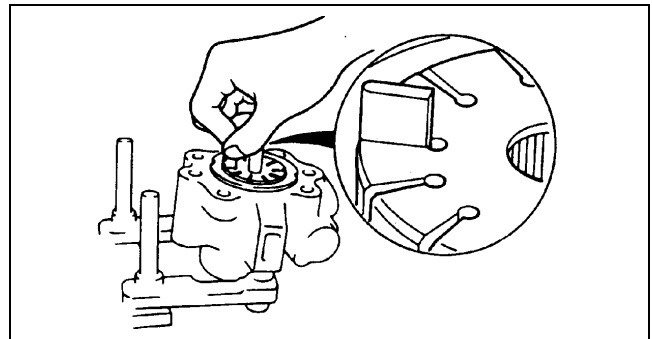

X3U612WBN

## Cam Ring Assembly Note

1. Install the cam ring in the front pump body with the mark facing upward.

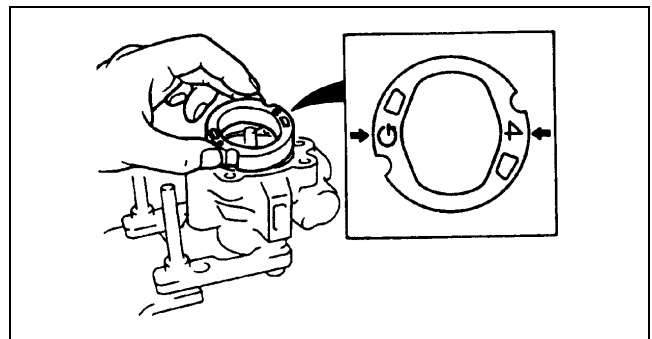

X3U612WBP

## Rear Pump Body Assembly Note

1. After installing the rear body, manually turn the shaft to verify that it rotates smoothly.

# ENGINE SPEED SENSING POWER STEERING

## POWER STEERING OIL PUMP (FS) DISASSEMBLY/ASSEMBLY

A3U061232650W03

### Note

- The following procedure is for replacement of the O-ring and oil seal only. Replace the pump component if other repairs are necessary.

- Disassemble in the order indicated in the table.
- Assemble in the reverse order of disassembly.

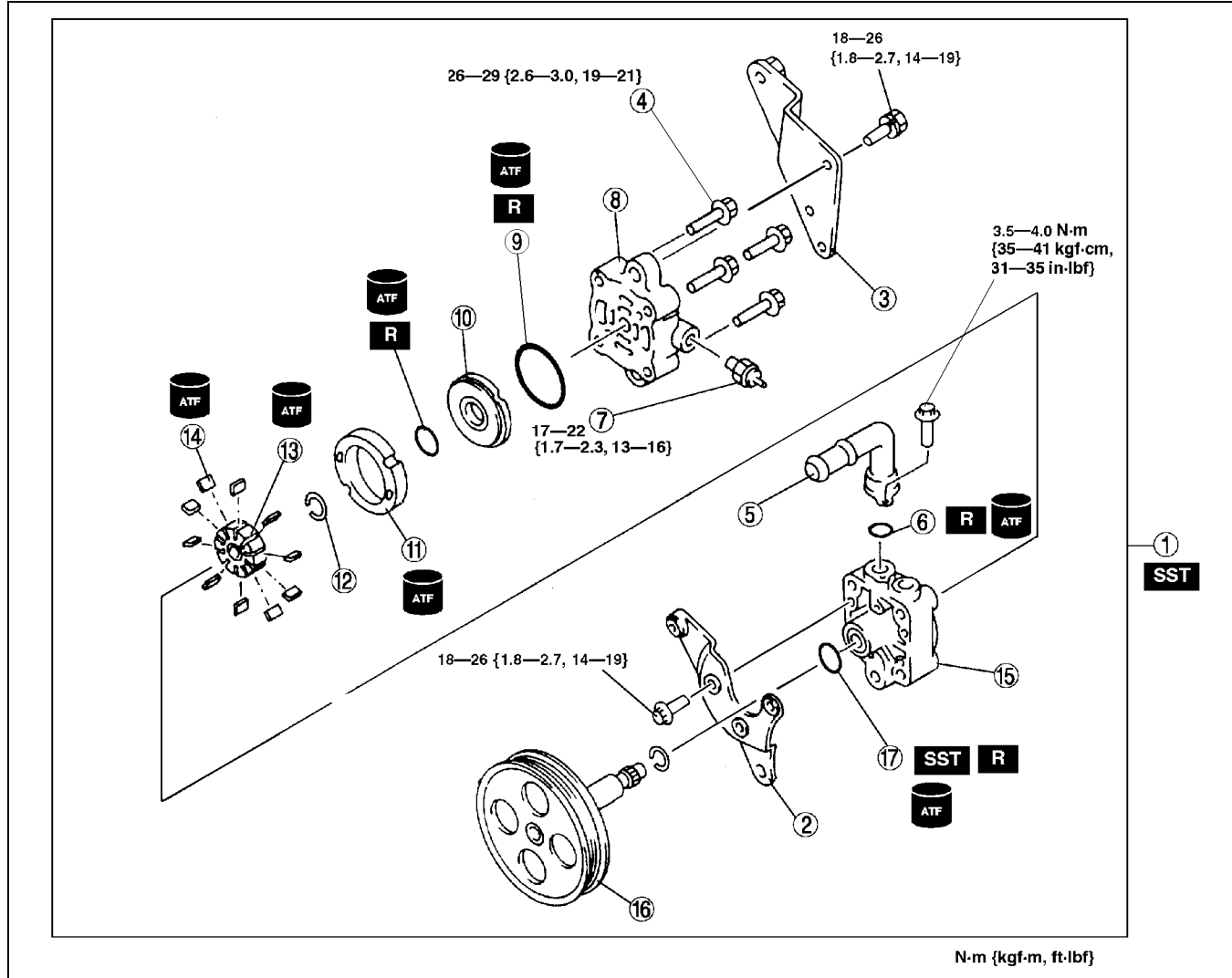

06-12

A3U0612W007

1	Power steering oil pump (See 06-12-26 Power Steering Oil Pump Component Disassembly Note)
2	Front bracket
3	Rear bracket
4	Bolt
5	Suction pipe
6	O-ring
7	Pressure switch component
8	Rear pump body (See 06-12-26 Rear Pump Body Assembly Note)
9	O-ring

10	Side plate
11	Cam ring (See 06-12-26 Cam Ring Assembly Note)
12	Backup ring
13	Rotor
14	Vane (See 06-12-26 Vane Assembly Note)
15	Front pump body
16	Shaft component
17	Oil seal (See 06-12-26 Oil Seal Assembly Note)

# TECHNICAL DATA

## 06-50 TECHNICAL DATA

### STEERING TECHNICAL DATA . . . . . 06-50-1

#### STEERING TECHNICAL DATA

A3U065001034W01

Item		Specification	
<b>ENGINE SPEED SENSING POWER STEERING</b>			
Steering column and shaft	Length (mm {in})	797.4—800.4 {31.40—31.51}	
Steering gear	Tie-rod end	Rotation torque (N·m {kgf·cm, in·lbf})	0.35—2.54 {3.5—26.0, 3.1—22.5}
		[Pull scale reading] (N {kgf, lbf})	3.5—25.4 {0.35—2.60, 0.78—5.72}
	Tie rod	Swinging torque (N·m {kgf·cm, in·lbf})	0.1—3.8 {1—39, 1—33}
		[Pull scale reading] (N {kgf, lbf})	0.6—24.5 {0.06—2.50, 0.14—5.50}
	Pinion shaft	Rotation torque (Center of rack ± 90°) (N·m {kgf·cm, in·lbf})	0.8—1.1 {8—11, 7—9}
		[Pull scale reading] (N {kgf, lbf})	8—11 {0.8—1.1, 1.7—2.4}
	Gear housing fluid pressure (MPa {kgf·cm <sup>2</sup> , psi})	8.34—8.82 {85.0—90.0, 1,209—1,279}	
Power steering oil pump	Oil pump fluid pressure (MPa {kgf·cm <sup>2</sup> , psi})	8.34—8.82 {85.0—90.0, 1,209—1,279}	
Power steering system	Fluid	Type	ATF M-III or equivalent (e.g. Dexron®III)
		Capacity (Approximate quantity) (L {US qt, Imp qt})	1.0 {1.1, 0.9}

06-50











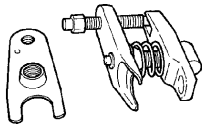
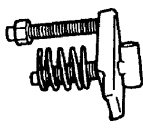

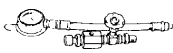
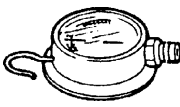
# SERVICE TOOLS

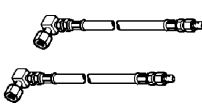
## 06-60 SERVICE TOOLS

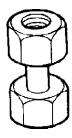
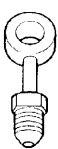
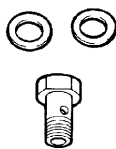
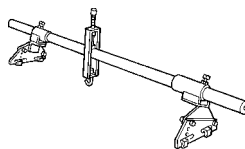
STEERING SST..... 06-60-1

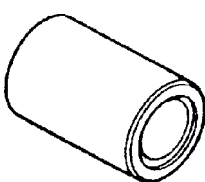
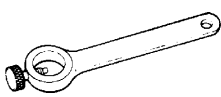
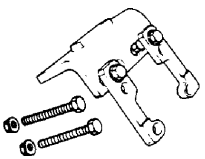

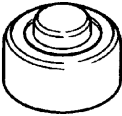
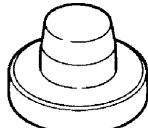



### STEERING SST

A3U066001034W01

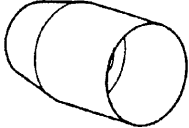
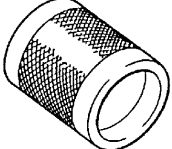
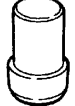
<p>49 T028 3A0</p> <p>Ball joint puller set</p> 	<p>49 T028 303</p> <p>Body (Part of 49 T028 3A0)</p> 	<p>49 T028 304</p> <p>Attachment (Part of 49 T028 3A0)</p> 
<p>49 1232 670B</p> <p>Power steering gauge set</p> 	<p>49 1232 672</p> <p>Gauge (Part of 49 1232 670B)</p> 	<p>49 1232 673</p> <p>Valve body (Part of 49 1232 670B)</p> 
<p>49 H002 671</p> <p>Adapter</p> 	<p>49 G032 3A4</p> <p>Power steering gauge adapter set</p> 	<p>49 G032 351</p> <p>Adapter (Part of 49 G032 3A4)</p> 
<p>49 G032 352</p> <p>Adapter (Part of 49 G032 3A4)</p> 	<p>49 G032 353</p> <p>Bolt (Part of 49 G032 3A4)</p> 	<p>49 E017 5A0</p> <p>Engine support</p> 
<p>49 B032 320</p> <p>Wrench</p> 	<p>49 B032 317</p> <p>Bearing &amp; oil seal remover</p> 	<p>49 8038 785A</p> <p>Dust boot installer</p> 
<p>49 0180 510B</p> <p>Preload measuring attachment</p> 	<p>49 F032 301</p> <p>Power steering pump hanger</p> 	<p>49 B001 797</p> <p>Handle</p> 
<p>49 N032 320</p> <p>Oil seal installer</p> 	<p>49 B032 331</p> <p>Oil seal installer</p> 	<p>49 B032 323</p> <p>Rod seal remover body</p> 

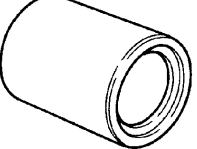
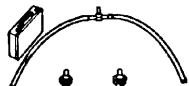
06-60

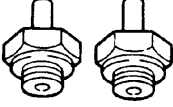
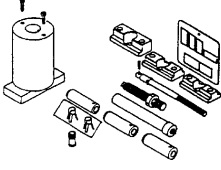
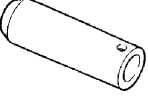
## SERVICE TOOLS

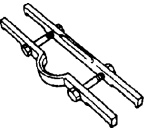
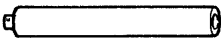
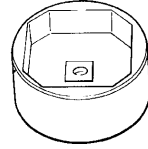
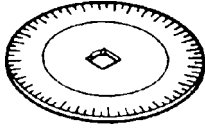
<p>49 E032 305</p> <p>Slipper seal protector</p> 	<p>49 E032 306</p> <p>Slipper seal former</p> 	<p>49 B032 325</p> <p>Rod seal guide</p> 
<p>49 B032 326</p> <p>Outer box protector</p> 	<p>49 B032 324</p> <p>Rod seal protector body</p> 	<p>49 T028 301</p> <p>Dust boot installer</p> 
<p>49 G032 3A1</p> <p>Joint hose set</p> 	<p>49 G032 317</p> <p>Hose (Part of 49 G032 3A1)</p> 	<p>49 B032 336</p> <p>Adapter set</p> 
<p>49 L011 0A0B</p> <p>Piston pin setting tool set</p> 	<p>49 L011 007</p> <p>Guide (Part of 49 L011 0A0B)</p> 	<p>49 G032 308</p> <p>Oil seal installer</p> 
<p>49 F032 303</p> <p>Handle</p> 	<p>49 N032 319A</p> <p>Support plate</p> 	<p>49 H032 338</p> <p>Joint shaft</p> 
<p>49 S032 317</p> <p>Socket wrench</p> 	<p>49 D032 316</p> <p>protoractor</p> 	<p>—</p>

# HEATER, VENTILATION & AIR CONDITIONING (HVAC)

# 07

SECTION

<b>SYMPTOM</b>	<b>CONTROL SYSTEM . . . . . 07-40</b>
TROUBLESHOOTING . . . . . 07-03	<b>TECHNICAL DATA . . . . . 07-50</b>
REFRIGERANT SYSTEM . . . . . 07-10	<b>SERVICE TOOLS . . . . . 07-60</b>
BASIC SYSTEM . . . . . 07-11	

## 07-03 SYMPTOM TROUBLESHOOTING

FOREWORD . . . . . 07-03-1	NO.4 NO TEMPERATURE CONTROL WITH CLIMATE CONTROL UNIT . . . . . 07-03-4
TROUBLESHOOTING INDEX . . . . . 07-03-1	NO.5 WINDSHIELD FOGGED . . . . . 07-03-5
NO.1 INSUFFICIENT AIR (OR NO AIR) BLOWN FROM VENTS . . . . . 07-03-2	NO.6 AIR FROM VENTS NOT COLD ENOUGH . . . . . 07-03-6
NO.2 AMOUNT OF AIR BLOWN FROM VENTS DOES NOT CHANGE . . . . . 07-03-2	NO.7 NO COOL AIR . . . . . 07-03-9
NO.3 AIRFLOW MODE DOES NOT CHANGE . . . . . 07-03-3	NO.8 NOISE WHILE OPERATING A/C SYSTEM . . . . . 07-03-12

07-03

### FOREWORD

A3U070301038W01

- See 00-00-1 HOW TO USE THIS MANUAL, Troubleshooting Procedure. Thoroughly read and understand the basic flow of troubleshooting in order to properly perform the procedures.
- The areas for inspection (steps) are given according to various circuit malfunctions. Use the chart below to verify the symptoms of the trouble in order to diagnose the appropriate area.

### TROUBLESHOOTING INDEX

A3U070301038W02

No.	TROUBLESHOOTING ITEM	DESCRIPTION	PAGE
1	Insufficient air (or no air) blown from vents.	<ul style="list-style-type: none"> <li>• Problem with each vent and/or duct.</li> </ul>	(See 07-03-2 NO.1 INSUFFICIENT AIR (OR NO AIR) BLOWN FROM VENTS)
2	Amount of air blown from vents does not change.	<ul style="list-style-type: none"> <li>• Malfunction in blower system.</li> </ul>	(See 07-03-2 NO.2 AMOUNT OF AIR BLOWN FROM VENTS DOES NOT CHANGE)
3	Airflow mode does not change.	<ul style="list-style-type: none"> <li>• Malfunction in heater unit and/or climate control unit airflow system.</li> </ul>	(See 07-03-3 NO.3 AIRFLOW MODE DOES NOT CHANGE)
4	No temperature control with climate control unit.	<ul style="list-style-type: none"> <li>• Malfunction in heater unit and/or climate control unit air mix system.</li> </ul>	(See 07-03-4 NO.4 NO TEMPERATURE CONTROL WITH CLIMATE CONTROL UNIT)
5	Windshield fogged.	<ul style="list-style-type: none"> <li>• A/C compressor does not operate while airflow mode is in DEFROSTER or HEAT/DEF modes.</li> <li>• Air intake mode does not change to FRESH while airflow mode is in DEFROSTER or HEAT/DEF modes.</li> </ul>	(See 07-03-5 NO.5 WINDSHIELD FOGGED)
6	Air from vents not cold enough.	<ul style="list-style-type: none"> <li>• Magnetic clutch operates but A/C system malfunctions.</li> </ul>	(See 07-03-6 NO.6 AIR FROM VENTS NOT COLD ENOUGH)
7	No cool air.	<ul style="list-style-type: none"> <li>• Magnetic clutch does not operate.</li> </ul>	(See 07-03-9 NO.7 NO COOL AIR)
8	Noise while operating A/C system.	<ul style="list-style-type: none"> <li>• Noise from magnetic clutch, A/C compressor, hose or refrigerant line.</li> </ul>	(See 07-03-12 NO.8 NOISE WHILE OPERATING A/C SYSTEM)

# SYMPTOM TROUBLESHOOTING

## NO.1 INSUFFICIENT AIR (OR NO AIR) BLOWN FROM VENTS

A3U070301038W03

<b>1</b>	<b>Insufficient air (or no air) blown from vents.</b>
<b>DESCRIPTION</b>	<ul style="list-style-type: none"> <li>• Problem with each vent and/or duct.</li> </ul>
<b>POSSIBLE CAUSE</b>	<ul style="list-style-type: none"> <li>• Malfunction in VENT mode system (Steps 1—4)</li> <li>• Malfunction in HEAT mode system (Step 5)</li> <li>• Malfunction in DEFROSTER mode system (Steps 6—8)</li> </ul>

### Diagnostic procedure

STEP	INSPECTION	ACTION	
1	<b>INSPECT AIRFLOW MODE CONTROL SYSTEM, STARTING FROM CLIMATE CONTROL UNIT</b> <ul style="list-style-type: none"> <li>• When airflow mode control dial is operated, is appropriate resistance felt and can it be moved to its full range?</li> </ul>	Yes	Go to next step.
		No	Go to Step 1 of troubleshooting index No. 3.
2	<b>CHECK TO SEE WHETHER MALFUNCTION IS IN VENT MODE OR ANOTHER MODES</b> <ul style="list-style-type: none"> <li>• Does air blow out when in VENT mode?</li> </ul>	Yes	Go to Step 5.
		No	Go to next step.
3	<b>INSPECT VENT</b> <ul style="list-style-type: none"> <li>• Is vent clogged?</li> </ul>	Yes	Remove obstruction, then go to Step 9.
		No	Go to next step.
4	<b>VERIFY THAT DUCT IN DASHBOARD IS INSTALLED</b> <ul style="list-style-type: none"> <li>• Is duct in dashboard properly installed?</li> </ul>	Yes	Inspect duct for clogging, deformity and air leakage, then go to Step 9.
		No	Install duct securely in the proper position, then go to Step 9.
5	<b>CHECK TO SEE WHETHER MALFUNCTION IS IN HEAT MODE OR DEFROSTER MODE</b> <ul style="list-style-type: none"> <li>• Does air blow out when in HEAT mode?</li> </ul>	Yes	Go to next step.
		No	Inspect vent for clogging, then go to Step 9.
6	<b>INSPECT DEFROSTER MODE</b> <ul style="list-style-type: none"> <li>• Does air blow out when in DEFROSTER mode?</li> </ul>	Yes	Operation is okay. Recheck malfunction symptoms.
		No	Go to next step.
7	<b>INSPECT VENT</b> <ul style="list-style-type: none"> <li>• Is vent clogged?</li> </ul>	Yes	Remove obstruction, then go to Step 9.
		No	Go to next step.
8	<b>VERIFY THAT DEFROSTER DUCT IS INSTALLED</b> <ul style="list-style-type: none"> <li>• Is defroster duct properly installed?</li> </ul>	Yes	Inspect duct for clogging, deformity, and air leakage, then go to next step.
		No	Install duct securely in the proper position, then go to next step.
9	<b>VERIFY THAT MALFUNCTION SYMPTOM OCCURS AFTER REPAIR</b> <ul style="list-style-type: none"> <li>• Does air blow out?</li> </ul>	Yes	Troubleshooting completed. Explain repairs to customer.
		No	Recheck malfunction symptoms, then repeat from Step 1 if malfunction recurs.

## NO.2 AMOUNT OF AIR BLOWN FROM VENTS DOES NOT CHANGE

A3U070301038W04

<b>2</b>	<b>Amount of air blown from vents does not change.</b>
<b>DESCRIPTION</b>	<ul style="list-style-type: none"> <li>• Malfunction in blower system.</li> </ul>
<b>POSSIBLE CAUSE</b>	<ul style="list-style-type: none"> <li>• Blower relay, blower motor, resistor, fan switch malfunction (Step 1)</li> <li>• Blower unit malfunction (Steps 2—4)</li> </ul>

### Diagnostic procedure

STEP	INSPECTION	ACTION	
1	<b>INSPECT BLOWER SYSTEM</b> <ul style="list-style-type: none"> <li>• Inspect the following systems and electrical parts. <ul style="list-style-type: none"> <li>— Blower relay</li> <li>— Blower motor</li> <li>— Resistor</li> <li>— Fan switch</li> <li>— Related wiring harnesses</li> </ul> </li> <li>• Are they okay?</li> </ul>	Yes	Go to next step.
		No	Repair or replace malfunctioning part, then go to Step 5.

## SYMPTOM TROUBLESHOOTING

STEP	INSPECTION	ACTION
2	<b>CHECK TO SEE WHETHER MALFUNCTION IS IN BLOWER UNIT OR ELSEWHERE</b> <ul style="list-style-type: none"> <li>• Turn ignition switch to ON position.</li> <li>• Turn fan switch on.</li> <li>• Recirculate air inside vehicle.</li> <li>• Does fan in blower unit rotate smoothly?</li> </ul>	Yes Go to Step 4.
		No Go to next step.
3	<b>INSPECT BLOWER UNIT</b> <ul style="list-style-type: none"> <li>• Inspect fan in blower unit.                             <ul style="list-style-type: none"> <li>— Is fan free of interference from blower unit case?</li> <li>— Is fan free of foreign material and obstructions?</li> </ul> </li> <li>• Is fan okay?</li> </ul>	Yes Go to next step.
		No Remove obstruction, repair or replace fan and blower unit case, then go to Step 5.
4	<b>INSPECT BLOWER UNIT INTAKE VENT</b> <ul style="list-style-type: none"> <li>• Is blower unit intake vent clogged?</li> </ul>	Yes Remove obstruction, then go to next step.
		No Inspect if there are any obstructions in passage between blower unit and heater unit, then go to next step.
5	<b>VERIFY THAT MALFUNCTION SYMPTOM OCCURS AFTER REPAIR</b> <ul style="list-style-type: none"> <li>• Does air blow out?</li> </ul>	Yes Troubleshooting completed. Explain repairs to customer.
		No Recheck malfunction symptoms, then repeat from Step 1 if malfunction recurs.

### NO.3 AIRFLOW MODE DOES NOT CHANGE

A3U070301038W05

07-03

<b>3</b>	<b>Airflow mode does not change.</b>
<b>DESCRIPTION</b>	<ul style="list-style-type: none"> <li>• Malfunction in heater unit and/or climate control unit airflow system.</li> </ul>
<b>POSSIBLE CAUSE</b>	<ul style="list-style-type: none"> <li>• Heater unit airflow mode link, airflow mode crank, airflow mode rod, airflow mode wire, wire clamp malfunction (Steps 1, 2)</li> <li>• Climate control unit rack-and-pinion, airflow mode wire malfunction (Step 3)</li> <li>• Malfunction in one or more heater unit doors (Steps 4, 5)</li> </ul>

#### Diagnostic procedure

STEP	INSPECTION	ACTION
1	<b>INSPECT HEATER UNIT AIRFLOW MODE SYSTEM</b> <ul style="list-style-type: none"> <li>• Inspect heater unit airflow mode links, airflow mode cranks, airflow mode rods, and wire clamp.                             <ul style="list-style-type: none"> <li>— Is there grease on links and cranks?</li> <li>— Are links, cranks and rods installed securely and in the proper position?</li> <li>— Is wire clamp free of deformation?</li> </ul> </li> <li>• Are above items okay?</li> </ul>	Yes Go to next step.
		No Apply grease or install links, cranks and rods securely in their proper positions, repair or replace wire clamp, then go to Step 6.
2	<b>VERIFY THAT AIRFLOW MODE WIRE FROM HEATER UNIT IS POSITIONED SECURELY AND CORRECTLY</b> <ul style="list-style-type: none"> <li>• Is airflow mode wire positioned securely and correctly in relation to the heater unit airflow mode links?</li> </ul>	Yes Go to next step.
		No Adjust airflow mode wire or install correctly, then go to Step 6.
3	<b>INSPECT CLIMATE CONTROL UNIT</b> <ul style="list-style-type: none"> <li>• Inspect climate control unit.                             <ul style="list-style-type: none"> <li>— Is rack-and-pinion properly engaged?</li> <li>— Is airflow mode wire properly installed in correct direction on rack?</li> </ul> </li> <li>• Are above items okay?</li> </ul>	Yes Go to next step.
		No Properly engage rack-and-pinion or install airflow mode wire in correct direction, then go to Step 6.
4	<b>INSPECT HEATER UNIT AIRFLOW MODE DOORS</b> <ul style="list-style-type: none"> <li>• Is there any foreign material or obstructions in any of heater unit doors?</li> </ul>	Yes Remove obstruction, then go to Step 6.
		No Go to next step.
5	<b>VERIFY THAT ALL AIRFLOW MODE DOORS WITHIN HEATER UNIT IS POSITIONED SECURELY AND PROPERLY</b> <ul style="list-style-type: none"> <li>• Are all doors within heater unit securely and properly positioned?</li> </ul>	Yes Inspect each door for cracks or damage, then go to next step.
		No Install malfunction doors securely in proper position, then go to next step.



## SYMPTOM TROUBLESHOOTING

STEP	INSPECTION	ACTION	
6	<b>VERIFY THAT MALFUNCTION SYMPTOM OCCURS AFTER REPAIR</b> <ul style="list-style-type: none"> <li>• Does airflow mode change?</li> </ul>	Yes	Troubleshooting completed. Explain repairs to customer.
		No	Recheck malfunction symptoms, then repeat from Step 1 if malfunction recurs.

### NO.4 NO TEMPERATURE CONTROL WITH CLIMATE CONTROL UNIT

A3U070301038W06

<b>4</b>	<b>No temperature control with climate control unit.</b>
<b>DESCRIPTION</b>	<ul style="list-style-type: none"> <li>• Malfunction in heater unit and/or climate control unit air mix system.</li> </ul>
<b>POSSIBLE CAUSE</b>	<ul style="list-style-type: none"> <li>• Heater unit air mix link, air mix crank, air mix rod, air mix wire, wire clamp malfunction (Steps 2, 3)</li> <li>• Climate control unit rack-and-pinion, air mix wire malfunction (Step 4)</li> <li>• Heater unit air mix door malfunction (Steps 5, 6)</li> <li>• Heater piping malfunction (Step 7)</li> </ul>

#### Diagnostic procedure

STEP	INSPECTION	ACTION	
1	<b>INSPECT COOLANT TEMPERATURE</b> <ul style="list-style-type: none"> <li>• Is coolant sufficiently warmed up?</li> </ul>	Yes	Go to next step.
		No	Warm engine up, then go to Step 8.
2	<b>INSPECT HEATER UNIT AIR MIX SYSTEM</b> <ul style="list-style-type: none"> <li>• Inspect heater unit air mix links, air mix cranks, air mix rods, and wire clamp.                             <ul style="list-style-type: none"> <li>— Is there grease on links and cranks?</li> <li>— Are links, cranks, and rods securely installed in their proper positions?</li> <li>— Is wire clamp free of deformation?</li> </ul> </li> <li>• Are above items okay?</li> </ul>	Yes	Go to next step.
		No	Apply grease or install links, cranks, and rods securely in their proper positions, repair or replace wire clamp, then go to Step 8.
3	<b>VERIFY THAT AIR MIX WIRE FROM HEATER UNIT IS POSITIONED SECURELY AND CORRECTLY</b> <ul style="list-style-type: none"> <li>• Is air mix wire securely installed in the correct position in relation to heater unit air mix links?</li> </ul>	Yes	Go to next step.
		No	Adjust air mix wire or install securely in correct position, then go to Step 8.
4	<b>INSPECT CLIMATE CONTROL UNIT</b> <ul style="list-style-type: none"> <li>• Inspect climate control unit.                             <ul style="list-style-type: none"> <li>— Is rack-and-pinion properly engaged?</li> <li>— Is air mix wire properly installed in correct position on rack?</li> </ul> </li> <li>• Are above items okay?</li> </ul>	Yes	Go to next step.
		No	Properly engage rack-and-pinion or install air mix wire in correct position, then go to Step 8.
5	<b>INSPECT HEATER UNIT</b> <ul style="list-style-type: none"> <li>• Is there any foreign material or obstruction in heater unit air mix doors?</li> </ul>	Yes	Remove obstruction, then go to Step 8.
		No	Go to next step.
6	<b>INSPECT HEATER UNIT AIR MIX DOORS</b> <ul style="list-style-type: none"> <li>• Is heater unit air mix door securely and properly installed?</li> </ul>	Yes	Inspect air mix door for cracks or damage, then go to next step.
		No	Install air mix door securely in proper position, then go to next step.
7	<b>INSPECT HEATER LINES</b> <ul style="list-style-type: none"> <li>• Inspect heater lines.                             <ul style="list-style-type: none"> <li>— Is heater piping free of damage and cracks?</li> <li>— Are heater piping connections free of engine coolant leakage?</li> <li>— Are heater piping connections securely tightened?</li> <li>— Are heater piping installation points on heater unit free of engine coolant leakage?</li> </ul> </li> <li>• Are above items okay?</li> </ul>	Yes	Operation is okay. Recheck malfunction symptoms.
		No	If heater piping connections is loosed, tighten connections with specified torque. Repair or replace heater piping, then go to next step.
8	<b>VERIFY THAT MALFUNCTION SYMPTOM OCCURS AFTER REPAIR</b> <ul style="list-style-type: none"> <li>• Does unit operate in every temperature setting?</li> </ul>	Yes	Troubleshooting completed. Explain repairs to customer.
		No	Recheck malfunction symptoms, then repeat from Step 1 if malfunction recurs.

# SYMPTOM TROUBLESHOOTING

## NO.5 WINDSHIELD FOGGED

A3U070301038W07

- When performing an asterisked (\*) troubleshooting inspection, shake the wiring harness and connectors while doing the inspection to discover whether poor contact points are the cause of any intermittent malfunctions. If there is a problem, check to make sure connectors, terminals and wiring harness are connected correctly and undamaged.

<b>5</b>	<b>Windshield fogged.</b>
<b>DESCRIPTION</b>	<ul style="list-style-type: none"> <li>A/C compressor does not operate while airflow mode is in DEFROSTER or HEAT/DEF modes.</li> <li>Air intake mode does not change to FRESH while airflow mode is in DEFROSTER or HEAT/DEF modes.</li> </ul>
<b>POSSIBLE CAUSE</b>	<ul style="list-style-type: none"> <li>Climate control unit (B+ signal) system malfunction (Steps 2, 4, 5)</li> <li>Air intake actuator malfunction (Steps 3, 7)</li> <li>Climate control unit (RECIRCULATE, FRESH signal) system malfunction (Steps 9—11)</li> <li>Malfunction in blower unit air intake doors (Steps 12, 13)</li> </ul>

### Diagnostic procedure

STEP	INSPECTION	ACTION	
1	<b>COOL AIR BLOW OUT INSPECTION</b> <ul style="list-style-type: none"> <li>When both A/C and fan switch in climate control unit are on, does cool air blow out from front vent?</li> </ul>	Yes	Go to next step.
		No	Go to Step 1 of troubleshooting index No.7.
2	<b>INSPECT CLIMATE CONTROL UNIT POWER SUPPLY FUSE FOR B+ SIGNAL</b> <ul style="list-style-type: none"> <li>Is climate control unit power supply fuse for B+ signal okay?</li> </ul>	Yes	Go to next step.
		No	Inspect for a short to ground on blown fuse circuit. <ul style="list-style-type: none"> <li>Repair or replace as necessary. Install appropriate amperage fuse.</li> </ul>
3	<b>INSPECT AIR INTAKE ACTUATOR</b> <ul style="list-style-type: none"> <li>Inspect air intake actuator.                             <ul style="list-style-type: none"> <li>Is there grease on link?</li> <li>Is link securely and properly positioned?</li> <li>Is link free of obstructions?</li> </ul> </li> <li>Are above items okay?</li> </ul>	Yes	Go to next step.
		No	Apply grease or install link properly and securely, remove obstruction, then go to Step 14.
*4	<b>INSPECT WIRING HARNESS BETWEEN FUSE BLOCK AND CLIMATE CONTROL UNIT FOR CONTINUITY</b> <ul style="list-style-type: none"> <li>Disconnect climate control unit connector (12-pin).</li> <li>Turn ignition switch to ON position.</li> <li>Test voltage at climate control unit connector terminal K (B+ signal).</li> <li>Is voltage <b>approximately 12 V</b>?</li> </ul>	Yes	Go to next step.
		No	Repair wiring harness between fuse block and climate control unit, then go to Step 14.
*5	<b>INSPECT WIRING HARNESS BETWEEN CLIMATE CONTROL UNIT AND GROUND FOR VOLTAGE</b> <ul style="list-style-type: none"> <li>Test voltage at climate control unit connector terminal E (Ground).</li> <li>Is voltage <b>approximately 0V</b>?</li> </ul>	Yes	Go to next step.
		No	Repair wiring harness between climate control unit and ground, then go to Step 14.
6	<b>VERIFY WHETHER MALFUNCTION IS IN BLOWER UNIT AIR INTAKE DOOR OR ELSEWHERE</b> <ul style="list-style-type: none"> <li>Turn ignition switch to LOCK position.</li> <li>Connect climate control unit connector (12-pin).</li> <li>Remove air intake actuator.</li> <li>Turn ignition switch to ON position.</li> <li>Set fan switch to 4th position.</li> <li>Does air intake mode (RECIRCULATE, FRESH) change smoothly when air intake link is operated by hand?</li> </ul>	Yes	Go to next step.
		No	Go to Step 12.
7	<b>INSPECT AIR INTAKE ACTUATOR</b> <ul style="list-style-type: none"> <li>Inspect air intake actuator. (See 07-40-4 AIR INTAKE ACTUATOR INSPECTION)</li> <li>Is it okay?</li> </ul>	Yes	Go to next step.
		No	Replace air intake actuator, go to Step 14.

07-03

## SYMPTOM TROUBLESHOOTING

STEP	INSPECTION	ACTION	
8	<b>INSPECT AIR INTAKE SELECTOR SWITCH AND MICROSWITCH IN CLIMATE CONTROL UNIT</b> <ul style="list-style-type: none"> <li>• Test voltage at climate control unit connector (12-pin) terminals A and I.</li> <li>• Is it okay?</li> </ul>	Yes	Go to next step.
		No	Replace climate control unit, then go to Step 14.
*9	<b>INSPECT WIRING HARNESS BETWEEN CLIMATE CONTROL UNIT AND AIR INTAKE ACTUATOR FOR CONTINUITY</b> <ul style="list-style-type: none"> <li>• Turn ignition switch to LOCK position.</li> <li>• Is there continuity between following climate control unit connector (12-pin) terminal and air intake actuator connector terminal?                             <ul style="list-style-type: none"> <li>— Terminal A —Terminal F (FRESH signal)</li> <li>— Terminal I —Terminal A (RECIRCULATE signal)</li> </ul> </li> </ul>	Yes	Go to next step.
		No	Repair wiring harness between climate control unit and air intake actuator, then go to Step 14.
*10	<b>INSPECT WIRING HARNESS BETWEEN CLIMATE CONTROL UNIT AND AIR INTAKE ACTUATOR FOR SHORT TO GROUND</b> <ul style="list-style-type: none"> <li>• Is there continuity between following climate control unit connector (12-pin) terminal and ground?                             <ul style="list-style-type: none"> <li>— Terminal A (FRESH signal)</li> <li>— Terminal I (RECIRCULATE signal)</li> </ul> </li> </ul>	Yes	Repair wiring harness between climate control unit and air intake actuator, then go to Step 14.
		No	Go to next step.
*11	<b>INSPECT WIRING HARNESS BETWEEN CLIMATE CONTROL UNIT AND AIR INTAKE ACTUATOR FOR SHORT TO B+</b> <ul style="list-style-type: none"> <li>• Turn ignition switch to ON position</li> <li>• Test voltage at following climate control unit connector (12-pin) terminal.                             <ul style="list-style-type: none"> <li>— Terminal A (FRESH signal)</li> <li>— Terminal I (RECIRCULATE signal)</li> </ul> </li> <li>• Is voltage <b>approximately 12 V</b>?</li> </ul>	Yes	Repair wiring harness between climate control unit and air intake actuator, then go to Step 14.
		No	Replace climate control unit, then go to Step 14.
12	<b>INSPECT BLOWER UNIT AIR INTAKE DOOR</b> <ul style="list-style-type: none"> <li>• Is there any foreign material or obstruction in blower unit air intake door?</li> </ul>	Yes	Remove obstruction, then go to Step 14.
		No	Go to next step.
13	<b>VERIFY THAT BLOWER UNIT AIR INTAKE DOOR IS POSITIONED SECURELY AND PROPERLY</b> <ul style="list-style-type: none"> <li>• Is blower unit air intake door securely and properly positioned?</li> </ul>	Yes	Inspect air intake door for cracks or damage, then go to next step.
		No	Install air intake door securely in proper position, then go to next step.
14	<b>VERIFY THAT MALFUNCTION SYMPTOM OCCURS AFTER REPAIR</b> <ul style="list-style-type: none"> <li>• Does malfunction disappear?</li> </ul>	Yes	Troubleshooting completed. Explain repairs to customer.
		No	Recheck malfunction symptoms, then repeat from Step 1 if malfunction recurs.

### NO.6 AIR FROM VENTS NOT COLD ENOUGH

A3U070301038W08

6	Air from vents not cold enough.
<b>DESCRIPTION</b>	<ul style="list-style-type: none"> <li>• Magnetic clutch operates but A/C system malfunctions.</li> </ul>
<b>POSSIBLE CAUSE</b>	<ul style="list-style-type: none"> <li>• Drive belt malfunction (Step 2)</li> <li>• Malfunction in blower unit or condenser (Steps 4, 5)</li> <li>• Malfunction in receiver/drier or expansion valve (valve closes too much) (Steps 8, 9)</li> <li>• Malfunction in refrigerant lines (Steps 10, 11)</li> <li>• A/C compressor system malfunction, insufficient compressor oil (Steps 15, 16)</li> <li>• Over filling of compressor oil, malfunction in expansion valve or heater unit air mix link system (Steps 17—19)</li> </ul>

#### Diagnostic procedure

STEP	INSPECTION	ACTION	
1	<b>INSPECT DRIVE BELT</b> <ul style="list-style-type: none"> <li>• Inspect drive belt. (See 01-10B-3 DRIVE BELT INSPECTION [FS])</li> <li>• Is it okay?</li> </ul>	Yes	Go to next step.
		No	Adjust or replace drive belt, then go to Step 20. (See 01-10B-4 DRIVE BELT ADJUSTMENT [FS])

## SYMPTOM TROUBLESHOOTING

STEP	INSPECTION	ACTION	
2	<b>INSPECT REFRIGERANT SYSTEM PERFORMANCE</b> <ul style="list-style-type: none"> <li>• Perform refrigerant system performance test. (See 07-10-2 REFRIGERANT SYSTEM PERFORMANCE TEST)</li> <li>• Is operation normal?</li> </ul>	Yes	Operation is normal. (Recheck malfunction symptoms.)
		No	Go to next step.
3	<b>CHECK TO SEE WHETHER MALFUNCTION IS IN BLOWER UNIT INTAKE AND CONDENSER OR ELSEWHERE</b> <ul style="list-style-type: none"> <li>• Are refrigerant high-pressure and low-pressure values both high?</li> </ul>	Yes	Go to next step.
		No	Go to Step 6.
4	<b>INSPECT BLOWER UNIT INTAKE</b> <ul style="list-style-type: none"> <li>• Is blower unit intake clogged?</li> </ul>	Yes	Remove obstruction, then go to Step 20. (If air does not reach evaporator within cooling unit, heat exchange does not occur and refrigerant pressure becomes high. Therefore, removal of obstruction is necessary.)
		No	Go to next step.
5	<b>INSPECT CONDENSER</b> <ul style="list-style-type: none"> <li>• Inspect condenser. (See 07-11-13 CONDENSER INSPECTION)</li> <li>• Is it okay?</li> </ul>	Yes	Adjust refrigerant to specified amount, then go to Step 20. (Excessive amount of refrigerant.)
		No	Replace condenser, or repair and clean condenser fins, then go to Step 20.
6	<b>CHECK TO SEE WHETHER MALFUNCTION IS IN EXPANSION VALVE, RECEIVER/DRIER AND REFRIGERANT LINES OR ELSEWHERE</b> <ul style="list-style-type: none"> <li>• Are refrigerant high-pressure and low-pressure values low?</li> </ul>	Yes	Go to next step.
		No	Go to Step 14.
7	<b>CHECK TO SEE WHETHER MALFUNCTION IS IN EXPANSION VALVE AND RECEIVER/DRIER OR ELSEWHERE</b> <ul style="list-style-type: none"> <li>• Immediately after A/C compressor operates, does refrigerant high-pressure value momentarily rise to correct value, then fall and stay below it? (Is there negative pressure on low-pressure side?)</li> </ul>	Yes	Go to next step.
		No	Go to Step 10.
8	<b>CHECK TO SEE WHETHER MALFUNCTION IS IN EXPANSION VALVE OR RECEIVER/DRIER</b> <ul style="list-style-type: none"> <li>• Turn A/C switch off and let air conditioner stop for <b>10 minutes</b>.</li> <li>• Start engine.</li> <li>• Turn both A/C switch and fan switch on.</li> <li>• Does malfunction occur after A/C compressor turns on?</li> </ul>	Yes	Go to next step.
		No	Replace receiver/drier and vacuum refrigerant line <b>more than 30 minutes</b> by vacuum pump, add refrigerant to specified level, then go to Step 20. (Since water has intermixed in receiver/drier and it is saturated, replacement is necessary.)
9	<b>VERIFY THAT EXPANSION VALVE HEAT-SENSING TUBE WITHIN COOLING UNIT IS POSITIONED SECURELY AND CORRECTLY</b> <ul style="list-style-type: none"> <li>• Is expansion valve heat-sensing tube within cooling unit securely installed in proper position?</li> </ul>	Yes	Replace expansion valve, then go to Step 20. (Since valve closes too much, replacement is necessary.)
		No	Install heat-sensing tube securely in proper position, then go to Step 20.
10	<b>INSPECT REFRIGERANT LINES</b> <ul style="list-style-type: none"> <li>• Inspect refrigerant lines.                             <ul style="list-style-type: none"> <li>— Is piping free of damage and cracks?</li> <li>— Are piping connections free of oil grime? (Visual inspection)</li> <li>— Are piping connections free of gas leakage?</li> <li>— Are piping installation points on condenser free of gas leakage?</li> <li>— Are piping installation points on receiver/drier free of gas leakage?</li> <li>— Are piping installation points on A/C compressor free of gas leakage?</li> <li>— Are piping installation points on cooling unit free of gas leakage?</li> </ul> </li> <li>• Perform gas leak inspection using gas leak tester.</li> <li>• Are above items okay?</li> </ul>	Yes	Go to next step.
		No	If piping or A/C component(s) are damaged or cracked, replace them. Then go to Step 20. If there is no damage, go to Step 13.

07-03

## SYMPTOM TROUBLESHOOTING

STEP	INSPECTION	ACTION
11	<b>INSPECT EVAPORATOR PIPING CONNECTIONS IN COOLING UNIT FOR GAS LEAKAGE</b> <ul style="list-style-type: none"> <li>Are piping connections for evaporator in cooling unit free of gas leakage?</li> </ul>	Yes If the vane makes a noise, add <b>10 ml {10 cc, 0.34 fl oz}</b> of compressor oil to the A/C compressor. Verify that the noise is no longer heard. Adjust refrigerant to specified amount, then go to Step 20.
		No If piping is damaged or cracked, replace it. Then go to Step 20. If there is no damage, go to next step.
12	<b>INSPECT EVAPORATOR PIPING CONNECTIONS IN COOLING UNIT FOR LOOSE</b> <ul style="list-style-type: none"> <li>Are piping connections for evaporator in cooling unit loose?</li> </ul>	Yes Tighten connections with specified torque, adjust both compressor oil and refrigerant to specified amount, then go to Step 20.
		No If the vane makes a noise, add <b>10 ml {10 cc, 0.34 fl oz}</b> of compressor oil to the A/C compressor. Verify that the noise is no longer heard. Replace O-ring on piping, adjust refrigerant to specified amount, then go to Step 20.
13	<b>INSPECT PIPING CONNECTIONS FOR LOOSE</b> <ul style="list-style-type: none"> <li>Are piping connections loose?</li> </ul>	Yes Tighten connections with specified torque, adjust both compressor oil and refrigerant to specified amount, then go to Step 20.
		No If the vane makes a noise, add <b>10 ml {10 cc, 0.34 fl oz}</b> of compressor oil to the A/C compressor. Verify that the noise is no longer heard. Replace O-ring on piping, adjust refrigerant to specified amount, then go to Step 20.
14	<b>CHECK TO SEE WHETHER MALFUNCTION IS IN EXPANSION VALVE, AIR MIX ACTUATOR AND COMPRESSOR OIL OR ELSEWHERE</b> <ul style="list-style-type: none"> <li>Does refrigerant high-pressure value hardly increase?</li> </ul>	Yes Go to next step. (Pressure hardly increases.)
		No Go to Step 17.
15	<b>CHECK TO SEE WHETHER MALFUNCTION IS IN COMPRESSOR OIL AMOUNT AND A/C COMPRESSOR OR ELSEWHERE</b> <ul style="list-style-type: none"> <li>When engine is racing, does high-pressure value increase?</li> </ul>	Yes Return to Step 3.
		No Go to next step.
16	<b>CHECK TO SEE WHETHER MALFUNCTION IS IN COMPRESSOR OIL AMOUNT OR A/C COMPRESSOR</b> <ul style="list-style-type: none"> <li>After compressor oil is replenished each <b>10 ml {10 cc, 0.34 fl oz}</b>, does high-pressure value increase?</li> </ul>	Yes Troubleshooting completed. (Explain to customer that cause was insufficient compressor oil.)
		No Replace A/C compressor, then go to Step 20. (Cause is defective A/C compressor.)
17	<b>CHECK TO SEE WHETHER MALFUNCTION IS IN EXPANSION VALVE OR ELSEWHERE</b> <ul style="list-style-type: none"> <li>Is only refrigerant low-pressure value high?</li> </ul>	Yes Go to Step 19.
		No Go to next step.
18	<b>VERIFY THAT AIR MIX IS INSTALLED SECURELY AND PROPERLY</b> <ul style="list-style-type: none"> <li>Are heater unit air mix links, air mix cranks, and air mix rods securely and properly installed?</li> </ul>	Yes Set fan switch to 4th position. Turn A/C switch on. Set FRESH mode. Set temperature control to MAX COLD. Set VENT mode. (1) Start and run the engine at <b>1,500 rpm for 10 minutes</b> . (2) Run the engine at idle for <b>1 minute</b> . (3) Within <b>12 seconds</b> , idle → <b>4,000 rpm</b> → idle. Perform cycle <b>5 times</b> . (4) Run the engine at idle for <b>30 seconds</b> . (5) Drain the compressor oil completely from the A/C compressor and verify the amount. <ul style="list-style-type: none"> <li>If there is <b>approximately 90 ml {90 cc, 3.0 fl oz}</b> of compressor oil, go to Step 20.</li> <li>If there is <b>more than 90 ml {90 cc, 3.0 fl oz}</b> of compressor oil, remove surplus oil and fill A/C compressor with <b>90 ml {90 cc, 3.0 fl oz}</b> of compressor oil. Repeat Steps (1) to (5). (Cause is excessive amount of compressor oil.)</li> </ul>
		No Repair or install links, cranks and rods securely in proper position, then go to Step 20.

## SYMPTOM TROUBLESHOOTING

STEP	INSPECTION	ACTION	
19	<b>VERIFY THAT EXPANSION VALVE HEAT-SENSING TUBE WITHIN COOLING UNIT IS POSITIONED SECURELY AND CORRECTLY</b> <ul style="list-style-type: none"> <li>Is expansion valve heat-sensing tube within cooling unit securely installed in proper position?</li> </ul>	Yes	Replace expansion valve, then go to next step. (Since valve opens too much, replacement is necessary.)
		No	Install heat-sensing tube securely in proper position, then go to next step.
20	<b>VERIFY THAT MALFUNCTION SYMPTOM OCCURS AFTER REPAIR</b> <ul style="list-style-type: none"> <li>Does cool air blow out? (Are results of refrigerant system performance test okay?)</li> </ul>	Yes	Troubleshooting completed. Explain repairs to customer.
		No	Recheck malfunction symptoms, then repeat from Step 1 if malfunction recurs.

### NO.7 NO COOL AIR

A3U070301038W09

- When performing an asterisked (\*) troubleshooting inspection, shake the wiring harness and connectors while doing the inspection to discover whether poor contact points are the cause of any intermittent malfunctions. If there is a problem, check to make sure connectors, terminals and wiring harness are connected correctly and undamaged.

7	No cool air.
<b>DESCRIPTION</b>	<ul style="list-style-type: none"> <li>Magnetic clutch does not operate.</li> </ul>
<b>POSSIBLE CAUSE</b>	<ul style="list-style-type: none"> <li>PCM A/C cut-off control system, coolant system malfunction (Steps 4, 17)</li> <li>A/C amplifier, A/C switch malfunction (Steps 6—10)</li> <li>PCM (A/C signal) system malfunction (Steps 11,12)</li> <li>Refrigerant pressure switch, refrigerant system malfunction (Steps 13, 14)</li> <li>PCM (IG1 signal) system malfunction (Steps 15, 16)</li> <li>A/C compressor system malfunction (Step 18)</li> <li>A/C relay system malfunction (Steps 19—21)</li> </ul>

07-03

### Diagnostic procedure

STEP	INSPECTION	ACTION	
1	<b>CHECK AIRFLOW</b> <ul style="list-style-type: none"> <li>Does air blow out?</li> </ul>	Yes	Go to next step.
		No	Go to Step 1 of troubleshooting indexes No. 1, 2.
2	<b>INSPECT A/C COMPRESSOR OPERATION</b> <ul style="list-style-type: none"> <li>Start engine.</li> <li>Turn both A/C switch and fan switch on.</li> <li>Does A/C compressor operate?</li> </ul>	Yes	Go to Step 1 of troubleshooting index No. 6.
		No	Go to next step.
*3	<b>CHECK TO SEE WHETHER MALFUNCTION (LACK OF CONTINUITY) IS IN CLIMATE CONTROL UNIT OR WIRING HARNESS (BETWEEN A/C SWITCH AND FAN SWITCH)</b> <ul style="list-style-type: none"> <li>Turn both A/C switch and fan switch off.</li> <li>Test voltage at climate control unit terminal D (A/C signal).</li> <li>Is voltage <b>approximately 12 V</b>?</li> </ul>	Yes	Go to next step.
		No	Repair wiring harness between climate control unit and fan switch, then go to Step 22.
4	<b>CHECK FOR DTCs IN PCM</b> <ul style="list-style-type: none"> <li>Check the DTC for the PCM on-board diagnostic system.</li> <li>Are any DTCs displayed? (See 01-03B-4 FOREWORD [FS]) (See 01-03A-4 FOREWORD [ZM])</li> </ul>	Yes	Go to appropriate inspection procedure.
		No	Go to next step.
*5	<b>CHECK TO SEE WHETHER MALFUNCTION IS IN A/C AMPLIFIER SYSTEM OR ELSEWHERE</b> <ul style="list-style-type: none"> <li>Turn ignition switch to LOCK position.</li> <li>Disconnect refrigerant pressure switch connector.</li> <li>Turn ignition switch to ON position.</li> <li>Set fan switch to 1st speed.</li> <li>Test voltage at following terminal of refrigerant pressure switch connector (on wiring harness side). — Terminal A (A/C signal)</li> <li>Is voltage <b>approximately 12 V</b> when A/C switch is off and <b>0 V</b> when it is on?</li> </ul>	Yes	Go to Step 11.
		No	Reconnect refrigerant pressure switch connector, then go to next step.

## SYMPTOM TROUBLESHOOTING

STEP	INSPECTION	ACTION
*6	<b>CHECK TO SEE WHETHER MALFUNCTION IS IN A/C AMPLIFIER (LACK OF CONTINUITY OR SHORT TO GROUND) AND WIRING HARNESS (LACK OF CONTINUITY OR SHORT TO GROUND BETWEEN FUSE BLOCK AND A/C AMPLIFIER) OR ELSEWHERE</b> <ul style="list-style-type: none"> <li>• Turn ignition switch to LOCK position.</li> <li>• Disconnect A/C amplifier connector.</li> <li>• Start engine.</li> <li>• Turn both A/C switch and fan switch on.</li> <li>• When A/C amplifier connector terminals B and C (on wiring harness side) are shorted, does cool air blow out?</li> </ul>	Yes Go to next step.
		No Go to Step 8.
*7	<b>CHECK TO SEE WHETHER MALFUNCTION (LACK OF CONTINUITY OR SHORT TO GROUND) IS IN A/C AMPLIFIER OR WIRING HARNESS (BETWEEN FUSE BLOCK AND A/C AMPLIFIER)</b> <ul style="list-style-type: none"> <li>• Turn ignition switch to ON position.</li> <li>• Test voltage at A/C amplifier connector terminal A (IG2 signal).</li> <li>• Is voltage <b>approximately 12 V</b>?</li> </ul>	Yes Inspect A/C amplifier, then go to Step 22.
		No Repair wiring harness between fuse block and A/C amplifier, then go to Step 22.
*8	<b>INSPECT WIRING HARNESS BETWEEN REFRIGERANT PRESSURE SWITCH AND A/C AMPLIFIER FOR SHORT TO B+</b> <ul style="list-style-type: none"> <li>• Test voltage at A/C amplifier connector terminal B (A/C signal).</li> <li>• Is voltage <b>approximately 12 V</b>?</li> </ul>	Yes Repair wiring harness between refrigerant pressure switch and A/C amplifier, then go to Step 22.
		No Go to next step.
*9	<b>INSPECT WIRING HARNESS BETWEEN REFRIGERANT PRESSURE SWITCH AND A/C AMPLIFIER FOR CONTINUITY</b> <ul style="list-style-type: none"> <li>• Turn ignition switch to LOCK position.</li> <li>• Disconnect refrigerant pressure switch connector.</li> <li>• Inspect for continuity between A/C amplifier connector terminal B (A/C signal) and refrigerant pressure switch connector terminal A.</li> <li>• Is there continuity?</li> </ul>	Yes Go to next step.
		No Repair wiring harness between refrigerant pressure switch and A/C amplifier, then go to Step 22.
*10	<b>CHECK TO SEE WHETHER MALFUNCTION (SHORT TO B+) IS IN CLIMATE CONTROL UNIT OR WIRING HARNESS (BETWEEN CLIMATE CONTROL UNIT AND A/C AMPLIFIER)</b> <ul style="list-style-type: none"> <li>• Turn ignition switch to ON position.</li> <li>• Turn A/C switch on.</li> <li>• Turn fan switch off.</li> <li>• Test voltage at climate control unit connector terminal B (A/C signal).</li> <li>• Is voltage <b>approximately 12 V</b>?</li> </ul>	Yes Inspect wiring harness between A/C amplifier and climate control unit, then go to Step 22.
		No Inspect climate control unit, then go to Step 22.
*11	<b>CHECK TO SEE WHETHER MALFUNCTION IS IN PCM (LACK OF CONTINUITY) AND WIRING HARNESS (BETWEEN PCM AND REFRIGERANT PRESSURE SWITCH) OR ANOTHER AREA</b> <ul style="list-style-type: none"> <li>• Test voltage at refrigerant pressure switch connector (on wiring harness side) terminal B (A/C signal).</li> <li>• Turn ignition switch to ON position.</li> <li>• Is voltage <b>approximately 12 V</b>?</li> </ul>	Yes Go to Step 13.
		No Go to next step.
*12	<b>CHECK TO SEE WHETHER MALFUNCTION IS IN PCM OR WIRING HARNESS (BETWEEN PCM AND REFRIGERANT PRESSURE SWITCH FOR CONTINUITY)</b> <ul style="list-style-type: none"> <li>• Test voltage at PCM connector (96-pin) terminal (A/C signal terminal).</li> <li>• Is voltage <b>approximately 12 V</b>?</li> </ul>	Yes Repair wiring harness between PCM and refrigerant pressure switch, then go to Step 22.
		No Inspect PCM, then go to Step 22.

## SYMPTOM TROUBLESHOOTING

STEP	INSPECTION	ACTION	
13	<b>CHECK TO SEE WHETHER MALFUNCTION IS IN REFRIGERANT PRESSURE SWITCH OR ELSEWHERE</b> <ul style="list-style-type: none"> <li>• When refrigerant pressure switch connector terminals A and B (on wiring harness side) are shorted, does cool air blow out?</li> </ul>	Yes	Go to next step.
		No	Undo short, reconnect refrigerant pressure switch connector, then go to Step 15.
14	<b>INSPECT REFRIGERANT PRESSURE SWITCH</b> <ul style="list-style-type: none"> <li>• Inspect refrigerant pressure switch. (See 07-40-9 REFRIGERANT PRESSURE SWITCH INSPECTION)</li> <li>• Is it okay?</li> </ul>	Yes	If refrigerant amount empty, replace receiver/drier, vacuum refrigerant line <b>more than 30 minutes</b> by vacuum pump, and add refrigerant to specified level, then go to Step 21.
		No	Replace refrigerant pressure switch, then go to Step 22.
*15	<b>CHECK TO SEE WHETHER MALFUNCTION IS IN MAGNETIC CLUTCH SYSTEM OR ELSEWHERE</b> <ul style="list-style-type: none"> <li>• Does magnetic clutch operate when terminal E of A/C relay connector is grounded?</li> </ul>	Yes	Undo short, then go to next step.
		No	Go to Step 18.
*16	<b>INSPECT WIRING HARNESS BETWEEN A/C RELAY AND PCM FOR CONTINUITY</b> <ul style="list-style-type: none"> <li>• Turn A/C switch off.</li> <li>• Test voltage at PCM connector (96-pin) terminal.</li> <li>• Is voltage <b>approximately 12 V</b>?</li> </ul>	Yes	Go to next step.
		No	Repair wiring harness between A/C relay and PCM, then go to Step 22.
*17	<b>INSPECT INPUT SIGNAL FOR PCM A/C CUT-OFF CONTROL</b> <ul style="list-style-type: none"> <li>• Inspect the following input signal components:                             <ul style="list-style-type: none"> <li>— Transaxle range switch and power steering pressure switch including PCM wiring harness (A/C cut-off control)</li> </ul> </li> <li>• Are they okay?</li> </ul>	Yes	Inspect coolant system operation. (See 01-03B-4 FOREWORD [FS]) (See 01-03A-4 FOREWORD [ZM])
		No	Inspect PCM.
*18	<b>CHECK TO SEE WHETHER MALFUNCTION IS IN MAGNETIC CLUTCH AND THERMAL PROTECTOR OR ELSEWHERE</b> <ul style="list-style-type: none"> <li>• Test voltage at magnetic clutch stator and thermal protector terminal A (A/C control signal).</li> <li>• Is voltage <b>approximately 12 V</b>?</li> </ul>	Yes	Inspect magnetic clutch, then go to Step 22.
		No	Go to next step.
19	<b>INSPECT A/C RELAY POWER SUPPLY FUSES</b> <ul style="list-style-type: none"> <li>• Are A/C relay power supply fuses okay?</li> </ul>	Yes	Go to next step.
		No	Inspect for a short to ground on blown fuse circuit. Repair or replace as necessary. Install appropriate amperage fuse.
*20	<b>INSPECT WIRING HARNESS BETWEEN FUSE BLOCK AND A/C RELAY FOR CONTINUITY</b> <ul style="list-style-type: none"> <li>• Turn ignition switch to ON position.</li> <li>• Test voltage at the following A/C relay connector terminals:                             <ul style="list-style-type: none"> <li>— Terminal A (IG2 signal)</li> <li>— Terminal C (A/C control signal)</li> </ul> </li> <li>• Is voltage <b>approximately 12 V</b>?</li> </ul>	Yes	Go to next step.
		No	Repair wiring harness between fuse block and A/C relay, then go to Step 22.
*21	<b>CHECK TO SEE WHETHER MALFUNCTION (LACK OF CONTINUITY) IS IN A/C RELAY OR WIRING HARNESS (BETWEEN A/C RELAY AND MAGNETIC CLUTCH)</b> <ul style="list-style-type: none"> <li>• Test voltage at A/C relay terminal D (A/C control signal).</li> <li>• Is voltage <b>approximately 12 V</b>?</li> </ul>	Yes	Repair wiring harness between A/C relay and stator and thermal protector, then go to next step.
		No	Inspect A/C relay, then go to next step.
22	<b>VERIFY THAT MALFUNCTION SYMPTOM OCCURS AFTER REPAIR</b> <ul style="list-style-type: none"> <li>• Does cool air blow out? (Is refrigerant system performance test result correct?)</li> </ul>	Yes	Troubleshooting completed. Explain repairs to customer.
		No	Recheck malfunction symptoms, then repeat from Step 1 if malfunction recurs.



# SYMPTOM TROUBLESHOOTING

## NO.8 NOISE WHILE OPERATING A/C SYSTEM

A3U070301038W10

<b>8</b>	<b>Noise while operating A/C system.</b>
<b>DESCRIPTION</b>	<ul style="list-style-type: none"> <li>• Noise from magnetic clutch, A/C compressor, hose or refrigerant line.</li> </ul>
<b>POSSIBLE CAUSE</b>	<ul style="list-style-type: none"> <li>• Magnetic clutch operation noise (Step 4)</li> <li>• A/C compressor vane noise (Steps 5—13)</li> <li>• A/C compressor slippage noise (Steps 14—17)</li> <li>• Hose or refrigerant line interference noise (Step 18)</li> </ul>

### Diagnostic procedure

STEP	INSPECTION		ACTION
1	<b>CHECK A/C COMPRESSOR VANE NOISE</b> <ul style="list-style-type: none"> <li>• Is there a jingling, popping, beeping, or buzzing sound (A/C compressor vane noise)?</li> </ul>	Yes	Go to Step 5.
		No	Go to next step.
2	<b>INSPECT A/C COMPRESSOR SLIPPAGE NOISE</b> <ul style="list-style-type: none"> <li>• Is there a squeaking or whirling sound (A/C compressor slippage noise)?</li> </ul>	Yes	Go to Step 14.
		No	Go to next step.
3	<b>INSPECT A/C COMPRESSOR INTERFERENCE NOISE</b> <ul style="list-style-type: none"> <li>• Is there a rattling or vibrating sound (interference noise)?</li> </ul>	Yes	Go to Step 18.
		No	Go to next step.
4	<b>INSPECT MAGNETIC CLUTCH OPERATION NOISE</b> <ul style="list-style-type: none"> <li>• Is there a clicking sound (magnetic clutch operation noise)?</li> </ul>	Yes	Adjust clearance between pressure plate of magnetic clutch and A/C compressor pulley, then go to Step 19. (See 07-40-7 MAGNETIC CLUTCH ADJUSTMENT)
		No	Condition is normal. (Recheck malfunction symptoms.)
5	<b>INSPECT A/C COMPRESSOR NOISE TIME</b> <ul style="list-style-type: none"> <li>• Is noise heard continuously for <b>more than 3 seconds</b> after A/C compressor comes on?</li> </ul>	Yes	Go to next step.
		No	Condition is normal. (Noise occurs for <b>2—3 seconds</b> immediately after A/C compressor turns on.)
6	<b>INSPECT IDLE SPEED</b> <ul style="list-style-type: none"> <li>• Inspect idle speed. (See 01-10B-26 Idle Speed Adjustment)</li> <li>• Is it okay?</li> </ul>	Yes	Go to next step.
		No	Adjust idle speed, then go to Step 19.
7	<b>INSPECT REFRIGERANT AMOUNT</b> <ul style="list-style-type: none"> <li>• Inspect refrigerant amount.</li> <li>• Is it okay?</li> </ul>	Yes	Go to Step 10.
		No	Go to next step.
8	<b>INSPECT REFRIGERANT LINES</b> <ul style="list-style-type: none"> <li>• Inspect refrigerant lines.                             <ul style="list-style-type: none"> <li>— Is piping free of damage and cracks?</li> <li>— Are piping connections free of oil grime? (Visual inspection)</li> <li>— Are piping connections free of gas leakage?</li> <li>— Are piping installation points on condenser free of gas leakage?</li> <li>— Are piping installation points on receiver/drier free of gas leakage?</li> <li>— Are piping installation points on A/C compressor free of gas leakage?</li> <li>— Are piping installation points on cooling unit free of gas leakage</li> <li>— Perform gas leak inspection using gas leak tester.</li> </ul> </li> <li>• Are above items okay?</li> </ul>	Yes	Go to next step.
		No	If piping or A/C component(s) is damaged or cracked, replace then go to Step 19. If there is gas leakage, repair or replace connection and replace receiver/drier*, then go to Step 19.
9	<b>INSPECT EVAPORATOR PIPING CONNECTIONS IN COOLING UNIT FOR GAS LEAKAGE</b> <ul style="list-style-type: none"> <li>• Are piping connections for evaporator in cooling unit free of gas leakage?</li> </ul>	Yes	Adjust refrigerant amount to specified level, then go to Step 19.
		No	If piping is damaged or cracked, replace then go to Step 19. If there is gas leakage, repair or replace connection and replace receiver/drier*, then go to Step 19.
10	<b>CHECK TO SEE WHETHER MALFUNCTION IS IN COMPRESSOR OIL OR ELSEWHERE</b> <ul style="list-style-type: none"> <li>• Add <b>20 ml {20 cc, 0.8 fl oz}</b> of compressor oil.</li> <li>• Is noise heard when racing engine?</li> </ul>	Yes	Go to next step.
		No	Troubleshooting completed. Explain repair to customer.

## SYMPTOM TROUBLESHOOTING

STEP	INSPECTION	ACTION	
11	<b>CHECK TO SEE WHETHER MALFUNCTION IS IN A/C COMPRESSOR OR ELSEWHERE</b> <ul style="list-style-type: none"> <li>• Drain compressor oil.</li> <li>• Is it contaminated with metal particles?</li> </ul>	Yes	Go to next step.
		No	Replace A/C compressor, then go to Step 19.
12	<b>CHECK TO SEE WHETHER MALFUNCTION IS SOMEWHERE IN A/C SYSTEM OR ELSEWHERE</b> <ul style="list-style-type: none"> <li>• Is compressor oil whitish and mixed with water?</li> </ul>	Yes	Replace entire A/C system (excluding heater), then go to Step 19.
		No	Go to next step.
13	<b>INSPECT A/C COMPRESSOR OIL</b> <ul style="list-style-type: none"> <li>• Is compressor oil darker than normal and contaminated with aluminum chips?</li> </ul>	Yes	Replace A/C compressor and receiver/drier, then go to Step 19. (Since A/C compressor may be worn and receiver/drier may be clogged, replacement of receiver/drier is necessary.)
		No	Condition is normal. Recheck malfunction symptoms.
14	<b>CHECK TO SEE WHETHER MALFUNCTION IS IN A/C COMPRESSOR OR ELSEWHERE</b> <ul style="list-style-type: none"> <li>• Is noise heard immediately after A/C compressor is stopped?</li> </ul>	Yes	Replace A/C compressor, then go to Step 19. (A/C compressor discharge valve left open)
		No	Go to next step.
15	<b>INSPECT DRIVE BELT</b> <ul style="list-style-type: none"> <li>• Inspect drive belt. (See 01-10B-3 DRIVE BELT INSPECTION [FS])</li> <li>• Is it okay?</li> </ul>	Yes	Go to next step.
		No	Adjust or replace drive belt, then go to Step 19. (See 01-03B-4 FOREWORD [FS]) (See 01-03A-4 FOREWORD [ZM])
16	<b>INSPECT DRIVE BELT CONDITION</b> <ul style="list-style-type: none"> <li>• Is drive belt worn?</li> <li>• Does it have foreign material imbedded in it, or have oil on it?</li> </ul>	Yes	Remove obstruction, remove oil, or replace drive belt, then go to Step 19.
		No	Go to next step.
17	<b>INSPECT MAGNETIC CLUTCH</b> <ul style="list-style-type: none"> <li>• Inspect magnetic clutch. (See 07-40-8 MAGNETIC CLUTCH INSPECTION)</li> <li>• Is it okay?</li> </ul>	Yes	Replace A/C compressor (excluding pressure plate, A/C compressor pulley, and stator), then go to Step 19.
		No	Replace magnetic clutch, then go to Step 19.
18	<b>CHECK TO SEE WHETHER MALFUNCTION IS IN A/C COMPRESSOR OR REFRIGERANT LINES</b> <ul style="list-style-type: none"> <li>• Is noise emitted from A/C compressor?</li> </ul>	Yes	Visually inspect A/C compressor, replace appropriate parts if necessary, then go to next step.
		No	If noise is due to refrigerant lines, repair detached or missing clips, tighten loose bolts, then go to next step.
19	<b>VERIFY THAT MALFUNCTION SYMPTOM OCCURS AFTER REPAIR</b> <ul style="list-style-type: none"> <li>• Has A/C compressor noise stopped?</li> </ul>	Yes	Troubleshooting completed. Explain repairs to customer.
		No	Recheck malfunction symptoms, then repeat from Step 1 if malfunction recurs.

07-03

\* : If there is gas leakage, air enters into the A/C system. The desiccant within the receiver/drier absorbs the moisture from the air and becomes saturated. If the A/C system is used in this condition, the inside of the A/C compressor will begin to rust due to this moisture, which may cause lock up or noise to occur. Therefore, replacement of the receiver/drier is necessary.

# 07-10 REFRIGERANT SYSTEM

## REFRIGERANT SYSTEM SERVICE

**WARNINGS** . . . . . 07-10-1

- Using/Handling Unapproved Refrigerant . . . . . 07-10-1
- Handling Refrigerant . . . . . 07-10-1
- Storing Refrigerant . . . . . 07-10-1

## REFRIGERANT SYSTEM SERVICE

**CAUTIONS** . . . . . 07-10-1

- Handling Compressor Oil . . . . . 07-10-1

## REFRIGERANT SYSTEM GENERAL

**PROCEDURES** . . . . . 07-10-2

- Manifold Gauge Set Installation . . . . . 07-10-2

## REFRIGERANT SYSTEM

**PERFORMANCE TEST** . . . . . 07-10-2

**REFRIGERANT PRESSURE CHECK** . . . 07-10-3

**REFRIGERANT RECOVERY** . . . . . 07-10-3

**REFRIGERANT CHARGING** . . . . . 07-10-3

- Charging Recycled R-134a Refrigerant . . . . . 07-10-3
- Charging New R-134a Refrigerant . . . . . 07-10-4

## REFRIGERANT SYSTEM SERVICE WARNINGS

A3U071001039W01

### Using/Handling Unapproved Refrigerant

- Using a flammable refrigerant, such as OZ-12, in this vehicle is dangerous. In an accident, the refrigerant may catch fire, resulting in serious injury or death. When servicing this vehicle, use only R-134a.
- Checking for system leakage on a vehicle that has been serviced with flammable refrigerant, such as OZ-12, is dangerous. Conventional leak detectors use an electronically generated arc which can ignite the refrigerant, causing serious injury or death. If a flammable refrigerant may have been used to service the system, or if you suspect a flammable refrigerant has been used, contact the local fire marshal or EPA office for information on handling the refrigerant.

07-10

### Handling Refrigerant

- Avoid breathing air conditioning refrigerant or lubricant vapor. Exposure may irritate eyes, nose and throat. Also, due to environmental concerns, use service equipment certified to meet the requirements of SAE J2210 (R-134a recycling equipment) when draining R-134a from the air conditioning system. If accidental system discharge occurs, ventilate work area before resuming service.
- Do not pressure test or leak test R-134a service equipment and/or vehicle air conditioning system with compressed air. Some mixtures of air and R-134a have been shown to be combustible at elevated pressures. These mixtures, if ignited, may cause injury or property damage. Additional health and safety information may be obtained from refrigerant manufacturers.
- Do not allow the refrigerant to leak near fire or any kind of heat. A poisonous gas may be generated if the refrigerant gas contacts fire or heat such as from cigarettes and heaters. When carrying out any operation that can cause refrigerant leakage, extinguish or remove the above-mentioned heat sources and maintain adequate ventilation.
- Handling liquid refrigerant is dangerous. A drop of it on the skin can result in localized frostbite. When handling the refrigerant, wear gloves and safety goggles. If refrigerant splashes into the eyes, immediately wash them with clean water and consult a doctor.

### Storing Refrigerant

- The refrigerant container is highly pressurized. If it is subjected to high heat, it could explode, scattering metal fragments and liquid refrigerant that can seriously injure you. Store the refrigerant at temperatures below 40 °C {104 °F}.

## REFRIGERANT SYSTEM SERVICE CAUTIONS

A3U071001039W02

### Handling Compressor Oil

- Use only ATMOS GU10 compressor oil for this vehicle. Using a PAG oil other than ATMOS GU10 compressor oil can damage the A/C compressor.
- Do not spill ATMOS GU10 compressor oil on the vehicle. A drop of compressor oil on the vehicle surface can eat away at the paint.
  - If oil gets on the vehicle, wipe it off immediately.

# REFRIGERANT SYSTEM

- **ATMOS GU10 compressor oil (PAG oil) has a higher moisture absorption efficiency than the previously used mineral oil. If moisture mixes with the compressor oil, the refrigerant system could be damaged. Therefore, install caps immediately after using the compressor oil or removing refrigerant system parts to prevent moisture absorption.**

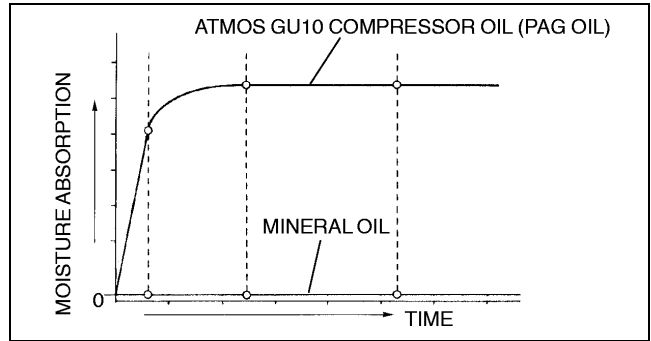

X3U710WA0

## REFRIGERANT SYSTEM GENERAL PROCEDURES

### Manifold Gauge Set Installation

A3U071001039W03

1. Fully close the valves of the manifold gauge.
2. Connect the charging hoses to the high- and low-pressure side joints of the manifold gauge.
3. Connect the quick couplers to the ends of the charging hoses.
4. Remove the caps from the charging valves.
5. Connect the quick couplers to the charging valves.

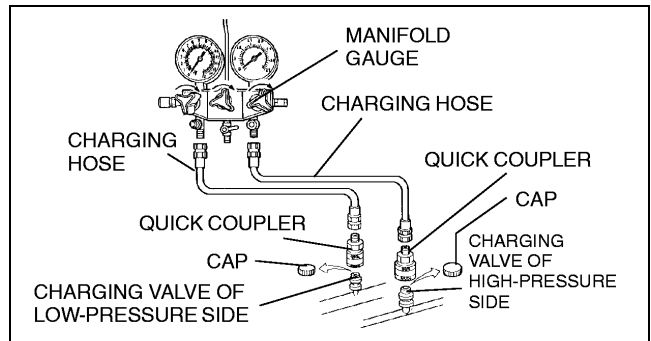

W6U710WA1

## REFRIGERANT SYSTEM PERFORMANCE TEST

A3U071001039W04

1. Perform refrigerant pressure check. (See 07-10-3 REFRIGERANT PRESSURE CHECK.)
  - If they are correct, go to the next step.
  - If not as specified, troubleshoot refrigerant system. (See 07-03-1 TROUBLESHOOTING INDEX.)
2. Place a dry-bulb thermometer in the driver-side center ventilator outlet.
3. Close the hood.
4. Warm up the engine and run it at a constant **1,500 rpm**.
5. Set the fan switch to 4th position.
6. Turn the A/C switch on.
7. Set the RECIRCULATE mode.
8. Set the temperature control to MAX COLD.
9. Set the VENT mode.
10. Close all the doors and all the windows.
11. Wait until the air conditioner output temperature stabilizes. The output temperature is stable when the A/C compressor is repeatedly turned on and off based on the A/C compressor control of A/C amplifier.
12. Record driver-side center ventilator temperature.
13. Determine and record ambient temperature.
14. Verify that the temperature reading is in the shaded zone.
  - If the performance is not within the shaded zone, troubleshoot the refrigerant system. (See 07-03-1 TROUBLESHOOTING INDEX.)

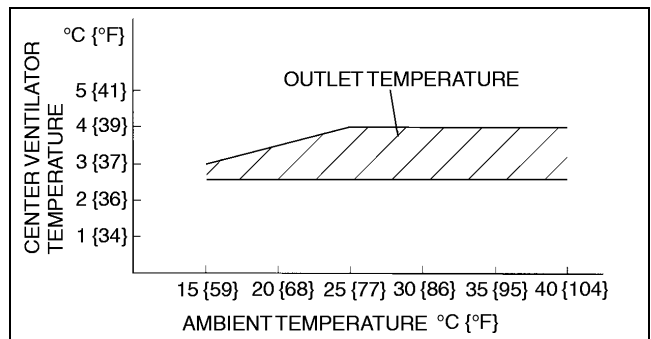

X3U710WA1

# REFRIGERANT SYSTEM

## REFRIGERANT PRESSURE CHECK

A3U071078834W01

1. Install the manifold gauge set.
2. Close the hood.
3. Warm up the engine and run it at a constant **1,500 rpm**.
4. Set the fan switch to 4th position.
5. Turn the A/C switch on.
6. Set the RECIRCULATE mode.
7. Set the temperature control to MAX COLD.
8. Set the VENT mode.
9. Close all the doors and all the windows.
10. Measure the ambient temperature and the high- and low-pressure side readings of the manifold gauge.
  - If the high- and low-pressure side readings are in the shaded zone as shown in the figure, the refrigerant system is normal.
  - If the pressure is abnormal, see No.6 of symptom troubleshooting. (See 07-03-6 NO.6 AIR FROM VENTS NOT COLD ENOUGH.)

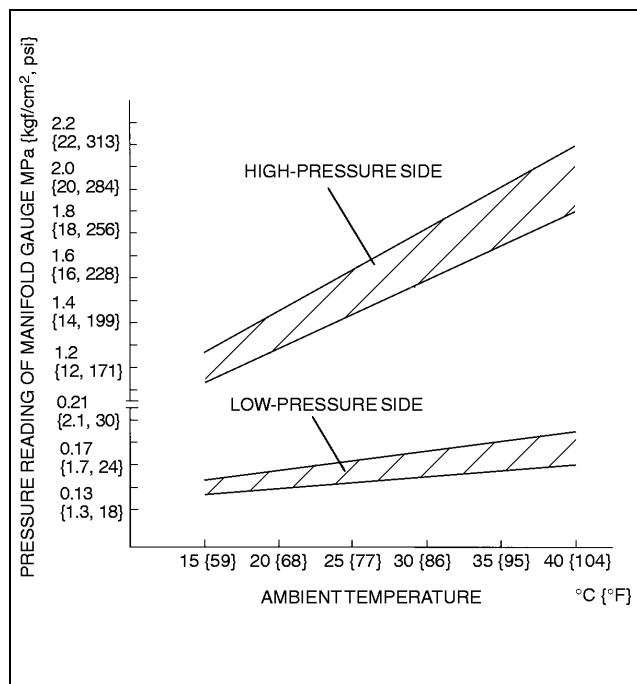

X3U710WA2

## REFRIGERANT RECOVERY

A3U071078834W02

### Warning

- Avoid breathing air conditioning refrigerant or lubricant vapor. Exposure may irritate eyes, nose and throat. Also, due to environmental concerns, use service equipment certified to meet the requirements of SAE J2210 (R-134a recycling equipment) when draining R-134a from the air conditioning system. If accidental system discharge occurs, ventilate work area before resuming service.

1. Connect an R-134a recovery/recycling/recharging device to the vehicle and follow the device manufacturer's instructions.

## REFRIGERANT CHARGING

A3U071078834W03

### Warning

- Avoid breathing air conditioning refrigerant or lubricant vapor. Exposure may irritate eyes, nose and throat. Also, due to environmental concerns, use service equipment certified to meet the requirements of SAE J2210 (R-134a recycling equipment) when draining R-134a from the air conditioning system. If accidental system discharge occurs, ventilate work area before resuming service.

### Caution

- Do not exceed the specification when charging the system with refrigerant. Doing so will decrease the efficiency of the air conditioner or damage the refrigeration cycle parts.

## Charging Recycled R-134a Refrigerant

1. Connect an R-134a recovery/recycling/recharging device to the vehicle and follow the device manufacturer's instructions.

# REFRIGERANT SYSTEM

## Charging New R-134a Refrigerant

1. Install the manifold gauge set.
2. Connect the tap pin side of the charging hose to the air purge valve of the manifold gauge.
3. Connect the vacuum pump hose to the center joint of the manifold gauge.
4. Connect the vacuum pump hose to the vacuum pump.
5. Connect the charging hose to the refrigerant tank.
6. Place the refrigerant tank on the scale.
7. Open all the valves of the manifold gauge.

### Caution

- Close the manifold gauge valve immediately after stopping the vacuum pump. If the valve is left open, the vacuum pump oil will back flow into the refrigeration cycle and cause a decrease in the efficiency of the air conditioner.

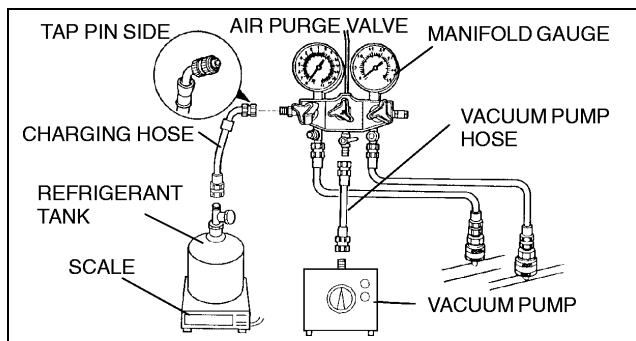

8. Start the vacuum pump and let it operate for 15 minutes.

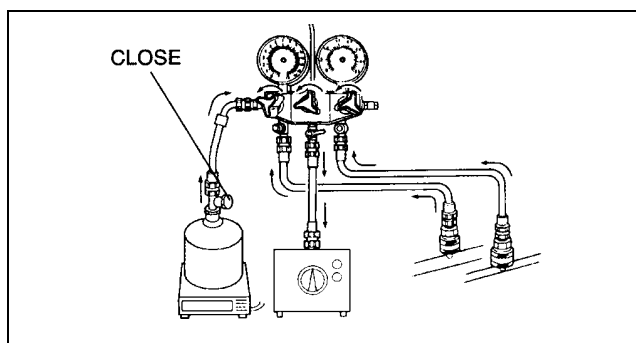

9. Verify that high- and low-pressure side readings of the manifold gauge are at **-101 kPa {-760 mmHg, -29.9 inHg}**. Close each valve of the manifold gauge.
10. Stop the vacuum pump and wait for 5 minutes.
11. Inspect the high- and low-pressure side readings of the manifold gauge.
  - If the reading has changed, inspect for leakage and then repeat from Step 7.
  - If the reading has not changed, and go to next step.
12. Open the valve of the refrigerant tank.
13. Weigh the refrigerant tank.

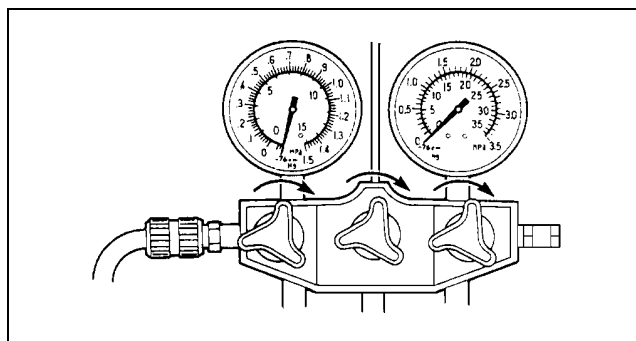

**Regular amount of refrigerant (approximate quantity)**  
**600 g {21.2 oz}**

### Warning

- If the refrigerant system is charged with a large amount of refrigerant when checking for gas leakage, and if any leakage should occur, the refrigerant will be released into the atmosphere. In order to prevent the accidental release of refrigerant which can destroy the ozone layer in the stratosphere, follow the proper procedures and charge with only a small amount of refrigerant when checking for gas leakage.
- If charging the system with refrigerant by service cans or refrigerant tank, running the engine with the high-pressure side valve open is dangerous. Pressure within the service cans or refrigerant tank will increase and they could explode, scattering metal fragments and liquid refrigerant that can seriously injure you. Therefore, do not open the high-pressure side valve while the engine is running.

### Caution

- Always begin charging of refrigerant from the high-pressure side. If charging is begun from the low-pressure side, the vanes of the A/C compressor will not be released and abnormal noise may result.

## REFRIGERANT SYSTEM

14. Open the high-pressure side valve of the manifold gauge.

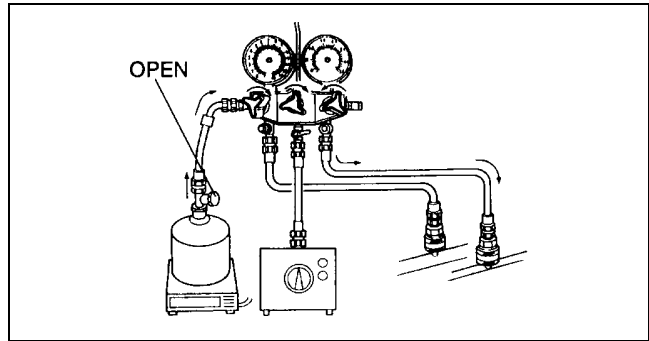

WLU710WAA

15. When the low-pressure side reading increases to **0.098 MPa {1.0 kgf/cm<sup>2</sup>, 14 psi}**, close the high-pressure side valve of the manifold gauge.
16. Inspect for leakage from the cooler pipe/hose connections using a gas leak tester.
- If there is no leakage, go to Step 18.
  - If leakage is found at a loose joint, tighten the joint, then go to the next step.
17. Inspect for leakage again.
- If there is no leakage after tightening the joint, go to the next step.
  - If there is still a leakage at the same joint, discharge the refrigerant and then repair the joint. Repeat the charging procedure from Step 7.

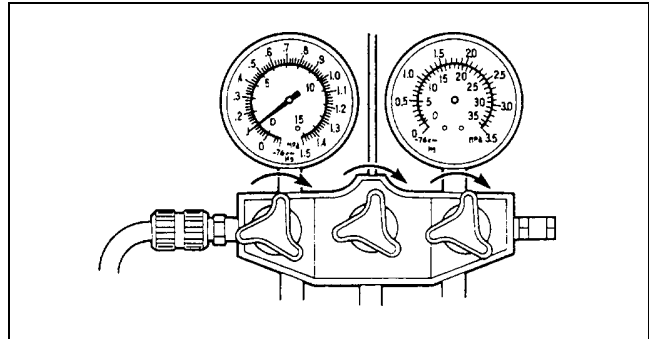

WLU710WAB

07-10

### Warning

- **If charging the system with refrigerant using service cans, running the engine with the high-pressure side valve open is dangerous. Pressure within the service cans will increase and the cans could explode, scattering metal fragments and liquid refrigerant that can seriously injure you. Therefore, do not open the high-pressure side valve while the engine is running.**

18. Open the high-pressure side valve of the manifold gauge and charge with refrigerant until the weight of refrigerant tank has decreased **300 g {10.6 oz}** from the amount in Step 13.

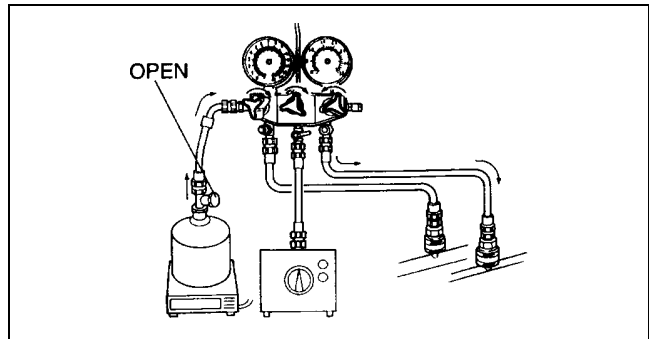

WLU710WAC

19. Close the high-pressure side valve of the manifold gauge.

### Warning

- **If charging the system with refrigerant using service cans, running the engine with the high-pressure side valve open is dangerous. Pressure within the service cans will increase and the cans could explode, scattering metal fragments and liquid refrigerant that can seriously injure you. Therefore, do not open the high-pressure side valve while the engine is running.**

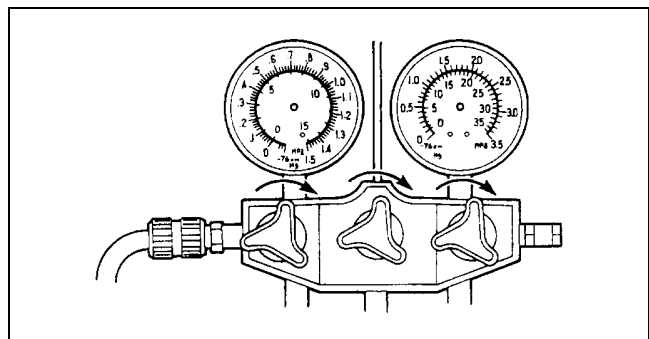

WLU710WAD

20. Start the engine and actuate the A/C compressor.

## REFRIGERANT SYSTEM

21. Open the low-pressure side valve of the manifold gauge and charge with refrigerant until the weight of the refrigerant tank has decreased **600 g {21.2 oz}** from the amount in Step 13.
22. Close the low-pressure side valve of the manifold gauge and the valve of the refrigerant tank.
23. Stop the engine and A/C compressor.
24. Inspect for leakage using a gas leak tester.
  - If there is no leakage, go to Step 26.
  - If leakage is found at a loose joint, tighten the joint, go to the next step.
25. Inspect for leakage again.
  - If there is no leakage after tightening the joint, and go to the next step.
  - If there is still leakage at the same joint, discharge the refrigerant and then repair the joint. Repeat the charging procedure from Step 7.
26. Disconnect the quick couplers from the charging valves.
27. Install the caps to the charging valves.

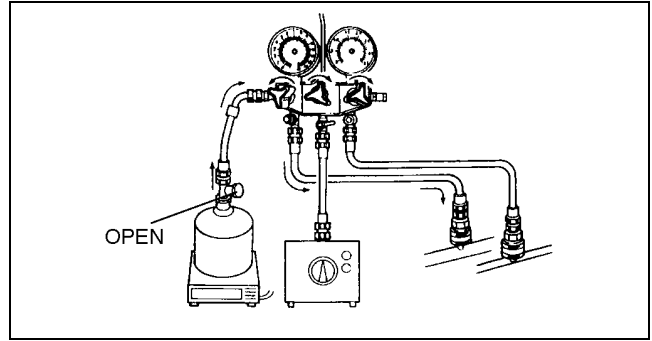

WLU710WAE

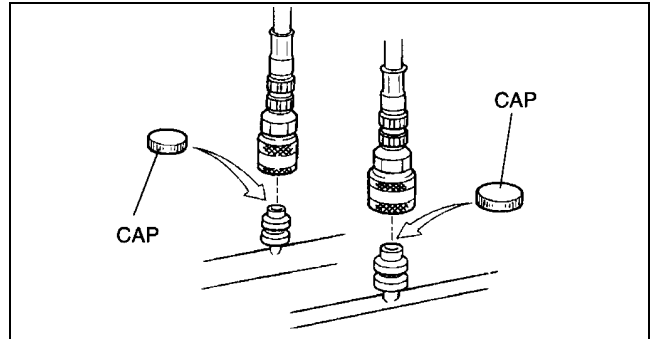

WLU710WAF



## **07-11 BASIC SYSTEM**

<p><b>BASIC SYSTEM LOCATION INDEX ... 07-11-2</b></p> <p><b>BLOWER UNIT</b></p> <p style="padding-left: 20px;"><b>REMOVAL/INSTALLATION ..... 07-11-3</b></p> <p><b>BLOWER UNIT</b></p> <p style="padding-left: 20px;"><b>DISASSEMBLY/ASSEMBLY ..... 07-11-3</b></p> <p><b>COOLING UNIT</b></p> <p style="padding-left: 20px;"><b>REMOVAL/INSTALLATION ..... 07-11-3</b></p> <p style="padding-left: 40px;">Cooling Unit Installation Note..... 07-11-4</p> <p><b>COOLING UNIT</b></p> <p style="padding-left: 20px;"><b>DISASSEMBLY/ASSEMBLY ..... 07-11-4</b></p> <p style="padding-left: 40px;">Expansion Valve Assembly Note..... 07-11-5</p> <p style="padding-left: 40px;">Evaporator Assembly Note ..... 07-11-6</p> <p style="padding-left: 40px;">Adhesive Sponge Rubber</p> <p style="padding-left: 60px;">Assembly Note..... 07-11-6</p> <p style="padding-left: 40px;">Insulator Assembly Note ..... 07-11-6</p> <p style="padding-left: 40px;">A/C Amplifier Assembly Note..... 07-11-6</p> <p style="padding-left: 40px;">Sensor Clamp Assembly Note..... 07-11-7</p> <p style="padding-left: 40px;">Polyethylene Foam Assembly Note... 07-11-7</p> <p><b>EVAPORATOR INSPECTION..... 07-11-7</b></p> <p><b>HEATER UNIT</b></p> <p style="padding-left: 20px;"><b>REMOVAL/INSTALLATION ..... 07-11-7</b></p> <p><b>HEATER UNIT</b></p> <p style="padding-left: 20px;"><b>DISASSEMBLY/ASSEMBLY ..... 07-11-9</b></p>	<p><b>HEATER CORE INSPECTION.....07-11-10</b></p> <p><b>AIRFLOW MODE MAIN LINK</b></p> <p style="padding-left: 20px;"><b>REMOVAL/INSTALLATION.....07-11-10</b></p> <p style="padding-left: 40px;">Airflow Mode Main Link</p> <p style="padding-left: 60px;">Installation Note .....07-11-10</p> <p><b>REAR DUCT</b></p> <p style="padding-left: 20px;"><b>REMOVAL/INSTALLATION.....07-11-11</b></p> <p><b>REAR HEAT DUCT</b></p> <p style="padding-left: 20px;"><b>REMOVAL/INSTALLATION.....07-11-11</b></p> <p><b>A/C COMPRESSOR</b></p> <p style="padding-left: 20px;"><b>REMOVAL/INSTALLATION.....07-11-11</b></p> <p style="padding-left: 40px;">A/C Compressor Installation Note.....07-11-12</p> <p><b>CONDENSER</b></p> <p style="padding-left: 20px;"><b>REMOVAL/INSTALLATION.....07-11-12</b></p> <p style="padding-left: 40px;">Condenser Installation Note .....07-11-13</p> <p><b>CONDENSER INSPECTION .....07-11-13</b></p> <p><b>RECEIVER/DRIER</b></p> <p style="padding-left: 20px;"><b>REMOVAL/INSTALLATION.....07-11-13</b></p> <p style="padding-left: 40px;">Receiver/drier Installation Note.....07-11-14</p> <p><b>REFRIGERANT</b></p> <p style="padding-left: 20px;"><b>LINES REMOVAL/INSTALLATION ....07-11-14</b></p> <p style="padding-left: 40px;">Refrigerant Lines Removal Note .....07-11-15</p> <p style="padding-left: 40px;">Refrigerant Lines Installation Note ....07-11-16</p>
---	--

---

**07-11**

# BASIC SYSTEM

## BASIC SYSTEM LOCATION INDEX

A3U071101040W01

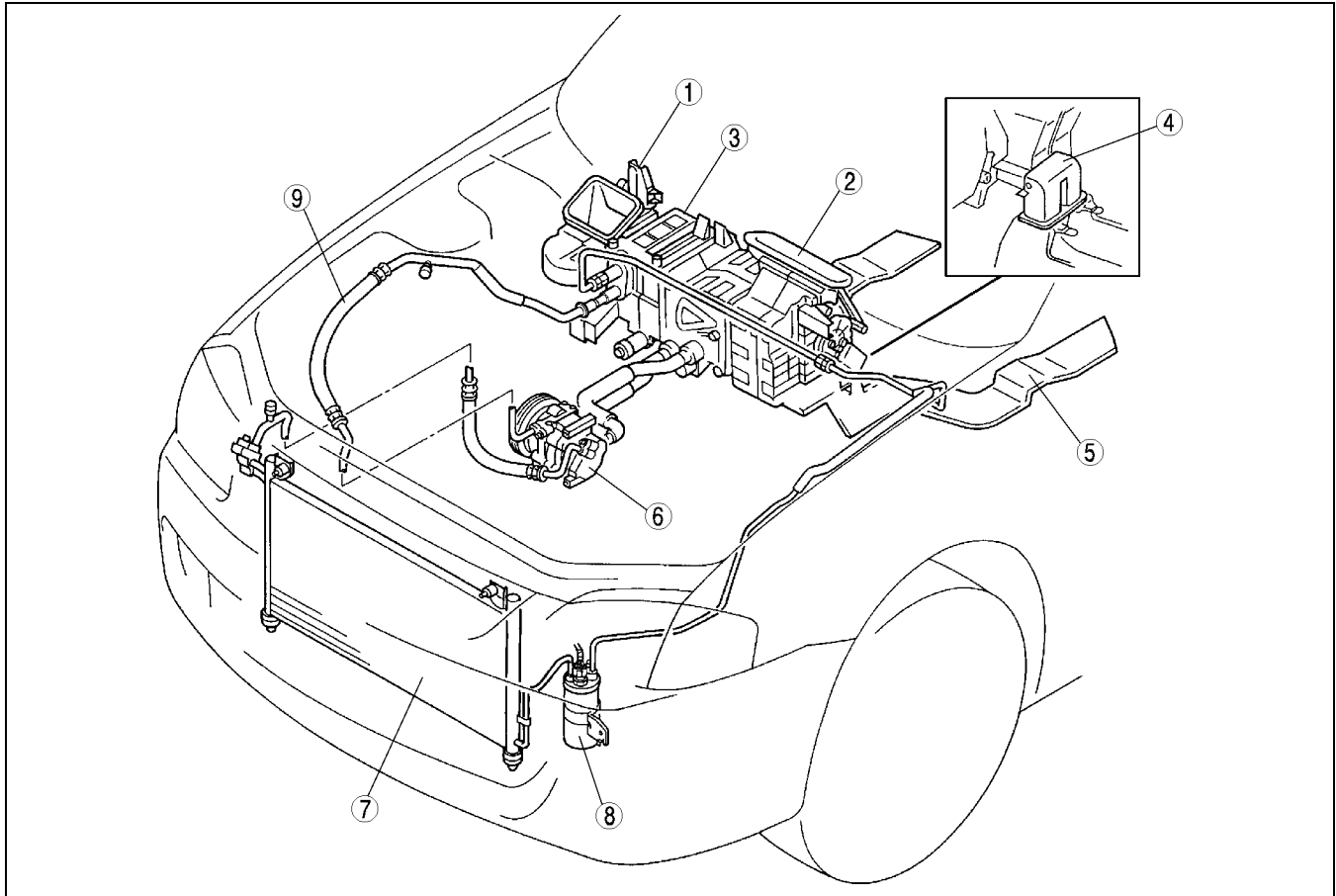

Z3U0711W001

1	Blower unit (See 07-11-3 BLOWER UNIT REMOVAL/ INSTALLATION) (See 07-11-3 BLOWER UNIT DISASSEMBLY/ ASSEMBLY)
2	Heater unit (See 07-11-7 HEATER UNIT REMOVAL/ INSTALLATION) (See 07-11-9 HEATER UNIT DISASSEMBLY/ ASSEMBLY)
3	Cooling unit (See 07-11-3 COOLING UNIT REMOVAL/ INSTALLATION) (See 07-11-4 COOLING UNIT DISASSEMBLY/ ASSEMBLY)
4	Rear duct (See 07-11-11 REAR DUCT REMOVAL/ INSTALLATION)

5	Rear heat duct (See 07-11-11 REAR HEAT DUCT REMOVAL/ INSTALLATION)
6	A/C compressor (See 07-11-11 A/C COMPRESSOR REMOVAL/ INSTALLATION)
7	Condenser (See 07-11-12 CONDENSER REMOVAL/ INSTALLATION) (See 07-11-13 CONDENSER INSPECTION)
8	Receiver/drier (See 07-11-13 RECEIVER/DRIER REMOVAL/ INSTALLATION)
9	Refrigerant lines (See 07-11-14 REFRIGERANT LINES REMOVAL/ INSTALLATION)

# BASIC SYSTEM

## BLOWER UNIT REMOVAL/INSTALLATION

A3U071161140W01

1. Disconnect the negative battery cable.
2. Remove the dashboard. (See 09-17-1 DASHBOARD REMOVAL/INSTALLATION.)
3. Remove the cooling unit. (See 07-11-3 COOLING UNIT REMOVAL/INSTALLATION.)
4. Remove the blower unit.
5. Install in the reverse order of removal.

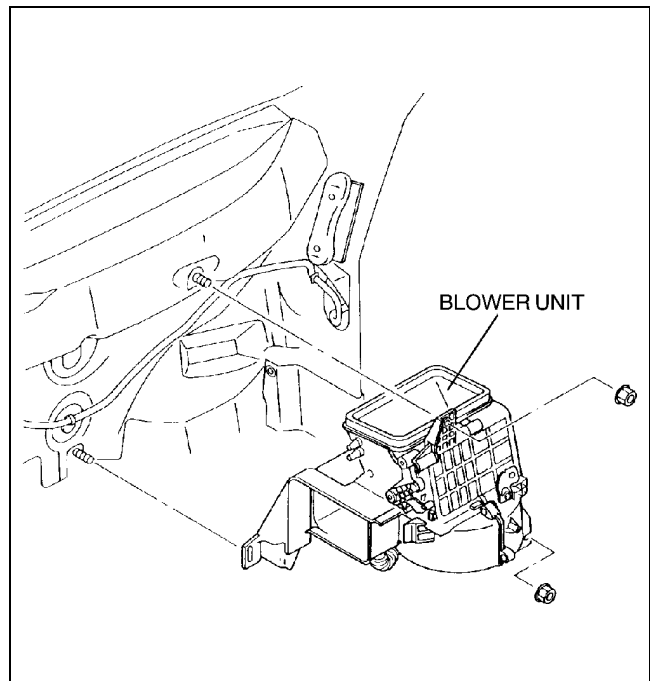

Z3U0711W002

07-11

## BLOWER UNIT DISASSEMBLY/ASSEMBLY

1. Disassemble in the order indicated in the table.

1	Blower motor
2	Blower harness
3	Air intake actuator
4	Air intake crank
5	Air intake door
6	Polyurethane protector
7	Blower case (1)
8	Blower case (2)

2. Assemble in the reverse order of disassembly.

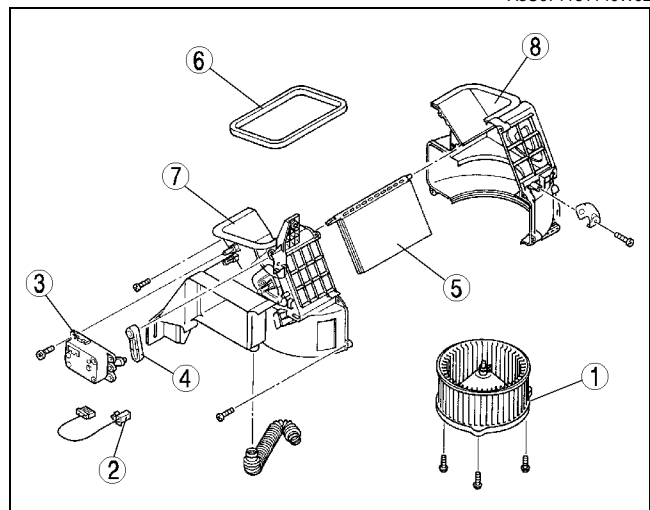

A3U071161140W02

Z3U0711W003

## COOLING UNIT REMOVAL/INSTALLATION

A3U071161520W01

1. Disconnect the negative battery cable.
2. Discharge the refrigerant from the system. (See 07-10-3 REFRIGERANT CHARGING.)
3. Remove the passenger-side lower panel.
4. Remove the glove compartment and glove compartment cover.

### Caution

- If moisture or foreign material enters the refrigeration cycle, cooling ability will be lowered and abnormal noise will occur. Always immediately plug all open fittings after removing any refrigeration cycle parts to keep moisture or foreign material out of the cycle.

## BASIC SYSTEM

5. Disconnect cooler pipe No.3 and cooler hose (LO). (See 07-11-15 Refrigerant Lines Removal Note.) (See 07-11-16 Refrigerant Lines Installation Note.)

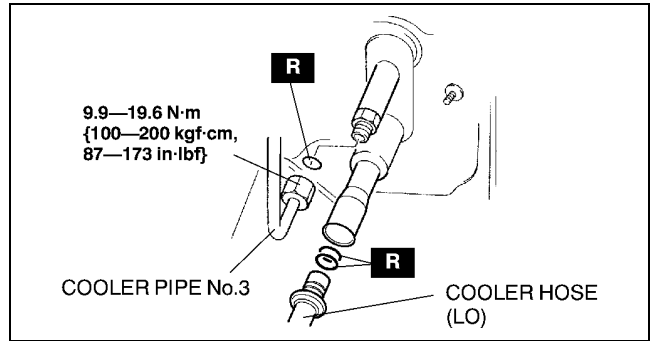

Z3U0711W004

6. Remove in the order indicated in the table. Do not allow compressor oil to spill.

1	Connector
2	Cooling unit (See 07-11-4 Cooling Unit Installation Note)

7. Install in the reverse order of removal.  
8. Perform the refrigerant system performance test. (See 07-10-2 REFRIGERANT SYSTEM PERFORMANCE TEST.)

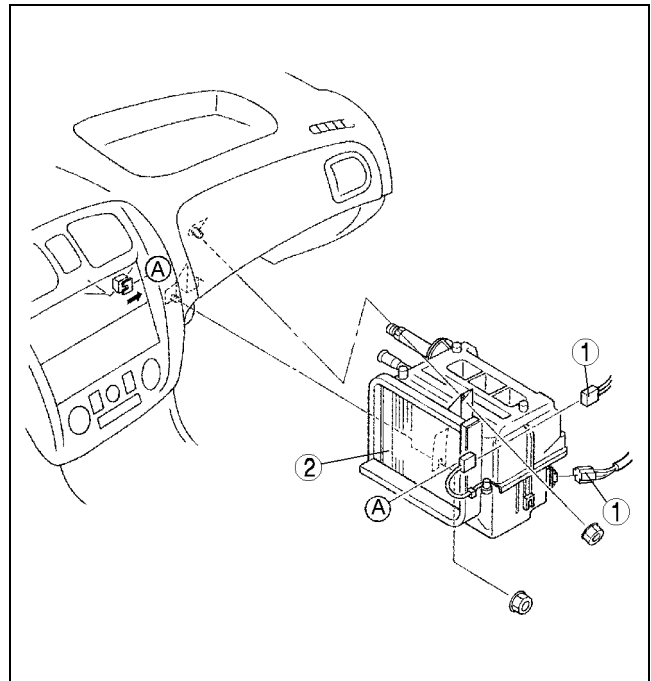

Z3U0711W005

### Cooling Unit Installation Note

1. When installing a new cooling unit (evaporator), add a supplemental amount of ATMOS GU10 compressor oil into the refrigeration cycle.

**Supplemental amount (approximate quantity)**  
30 ml {30 cc, 1.0 fl oz}

### COOLING UNIT DISASSEMBLY/ASSEMBLY

A3U071161520W02

1. Disassemble in the order indicated in the table.

#### Caution

- If moisture or foreign material enters the refrigeration cycle, cooling ability will be lowered and abnormal noise will occur. Always immediately plug all open fittings after removing any refrigeration cycle parts to keep moisture or foreign material out of the cycle.

# BASIC SYSTEM

1	Resistor
2	Polyurethane foam
3	Polyurethane protector (1)
4	Polyurethane protector (2)
5	Cooler case (1)
6	Cooler case (2)
7	Polyethylene foam (See 07-11-7 Polyethylene Foam Assembly Note)
8	Sensor clamp (See 07-11-7 Sensor Clamp Assembly Note)
9	A/C amplifier (See 07-11-6 A/C Amplifier Assembly Note)
10	Insulator (See 07-11-6 Insulator Assembly Note)
11	Adhesive sponge rubber (See 07-11-6 Adhesive Sponge Rubber Assembly Note)
12	Sponge rubber
13	Polyurethane protector (3)
14	Polyethylene protector
15	Polyurethane protector (4)
16	Evaporator (See 07-11-6 Evaporator Assembly Note)
17	Expansion valve (See 07-11-5 Expansion Valve Assembly Note)

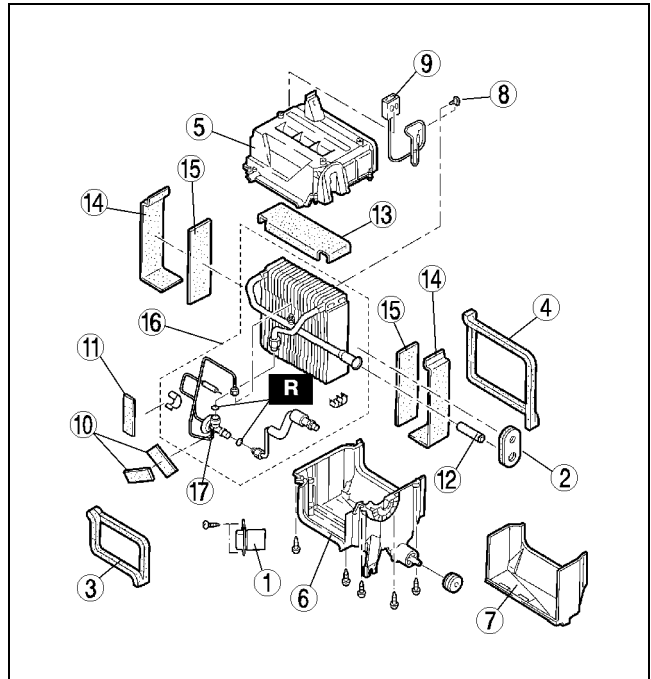

Z3U0711W006

07-11

2. Assemble in the reverse order of disassembly.

## Expansion Valve Assembly Note

1. Apply compressor oil to the O-rings and connect the joint.
2. Tighten the nut of the joint by hand.
3. Tighten the joint with the specified torque with a spanner and torque wrench.
4. Assemble the heat-sensing tube as shown in the figure.
5. Route the capillary tube as shown in the figure.

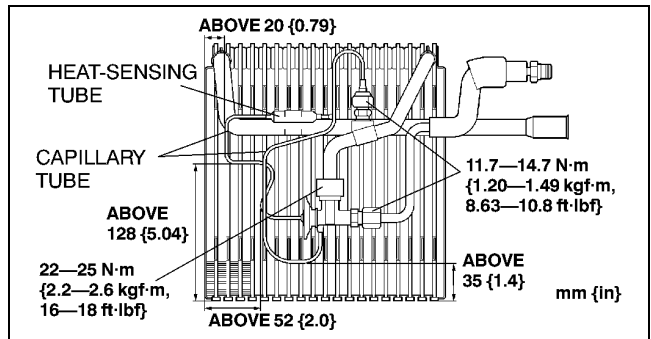

Z3U0711W007

6. Verify that the capillary tube is not in the shaded zone

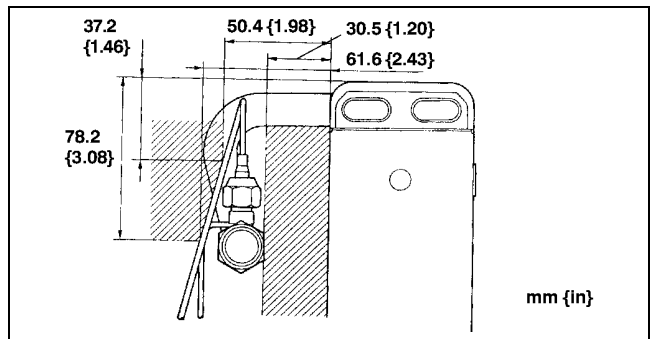

Z3U0711W008

# BASIC SYSTEM

## Evaporator Assembly Note

1. Verify that the dent caused by contact with the polyurethane protector and cooler case (1) in the shaded zone is 3 mm {0.12 in} or less.

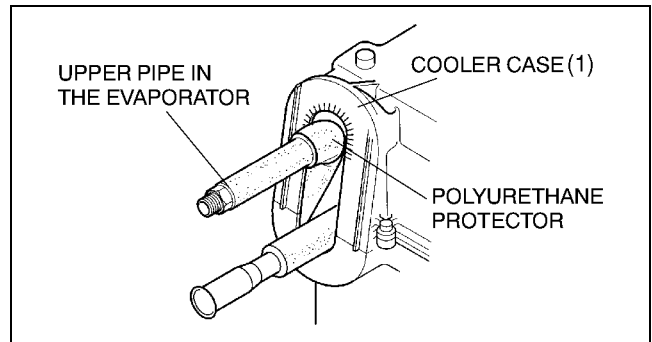

A3U0711W002

## Adhesive Sponge Rubber Assembly Note

1. Attach the adhesive sponge rubber so that the heat sensing tube is hidden.

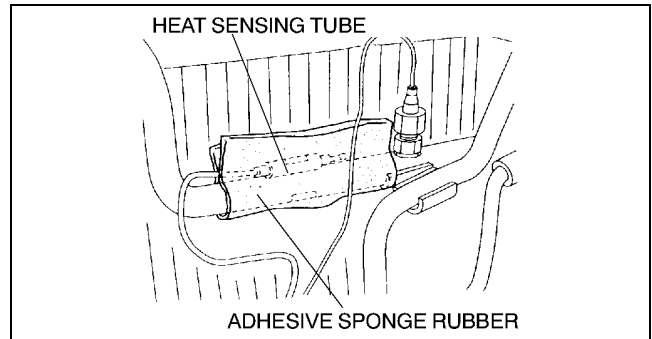

Z3U0711W010

## Insulator Assembly Note

1. Make the two insulators cross.
2. Attach the insulator so that the shaded zone of expansion valve is hidden.

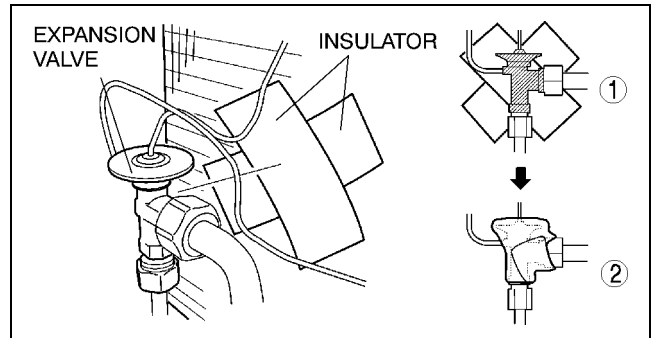

Z3U0711W011

## A/C Amplifier Assembly Note

1. Assemble the evaporator temperature sensor as shown in the figure.

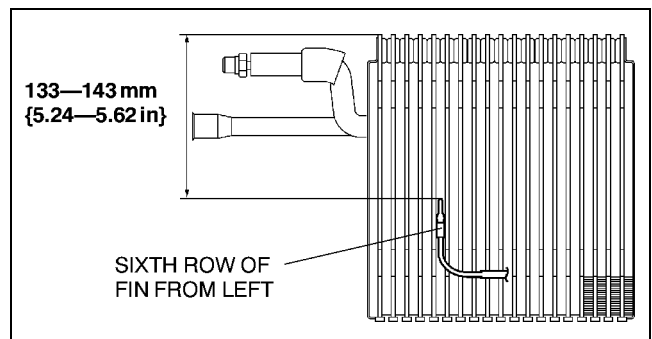

Z3U0711W012

## BASIC SYSTEM

### Sensor Clamp Assembly Note

1. Assemble the sensor clamp as shown in the figure.

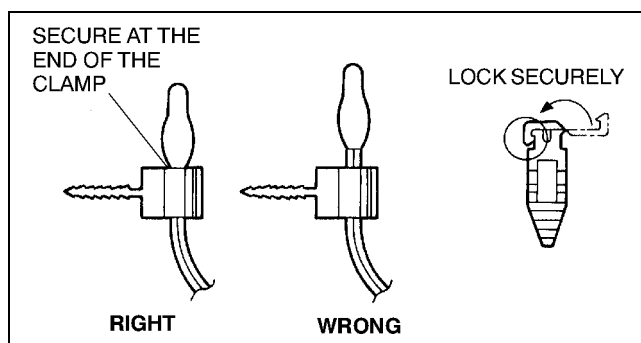

Z3U0711W013

### Polyethylene Foam Assembly Note

1. Apply the adhesive to a range of **50 mm {1.97 in}** from the edge of polyethylene foam, and around the drain outlet. Apply the polyethylene foam to the cooler case (2).

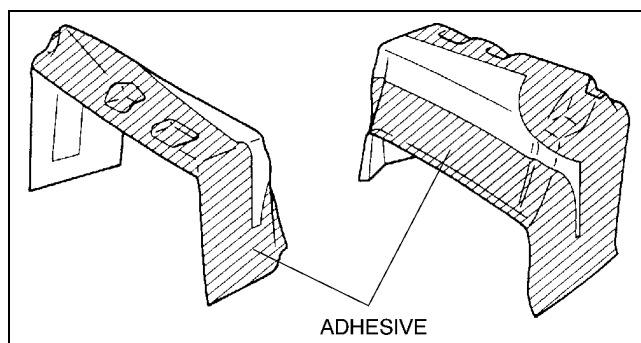

Z3U0711W014

07-11

### EVAPORATOR INSPECTION

1. Remove the cooling unit. (See 07-11-3 COOLING UNIT REMOVAL/INSTALLATION.)
2. Remove the evaporator from the cooling unit.
3. Inspect for cracks, damage, and oil leakage.
  - If any problems are found, replace the evaporator.
4. Inspect for bent fins.
  - If any are bent, use a flathead screwdriver to straighten them.

A3U071161810W01

### HEATER UNIT REMOVAL/INSTALLATION

1. Disconnect the negative battery cable.
2. Drain the engine coolant. (See 01-12-3 ENGINE COOLANT REPLACEMENT.)
3. Remove the dashboard. (See 09-17-1 DASHBOARD REMOVAL/INSTALLATION.)
4. Remove the cooling unit. (See 07-11-3 COOLING UNIT REMOVAL/INSTALLATION.)
5. Remove in the order indicated in the table.

A3U071161130W01

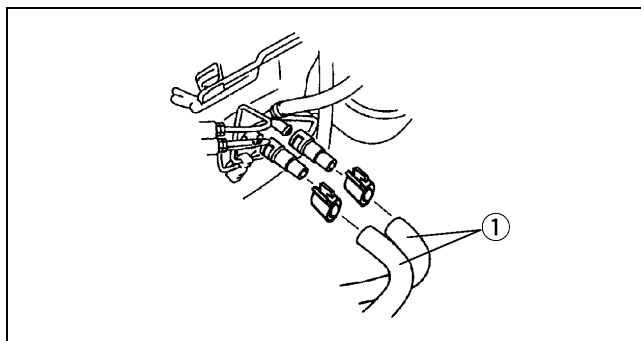

X3U711WAB

## BASIC SYSTEM

1	Heater hose
2	Heater unit
3	Rear duct
4	Heat duct

6. Install in the reverse order of removal.

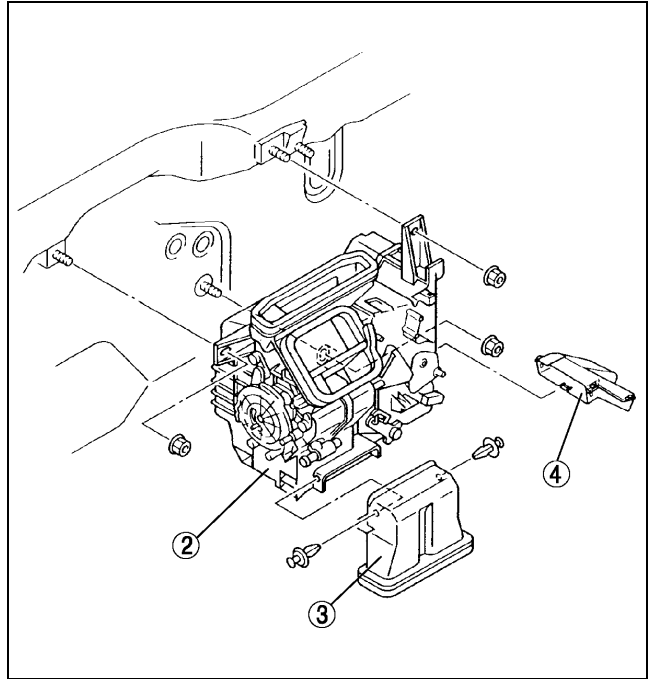

X3U711WAC



# BASIC SYSTEM

## HEATER UNIT DISASSEMBLY/ASSEMBLY

A3U071161130W02

1. Disassemble in the order indicated in the table.
2. Assemble in the reverse order of disassembly.

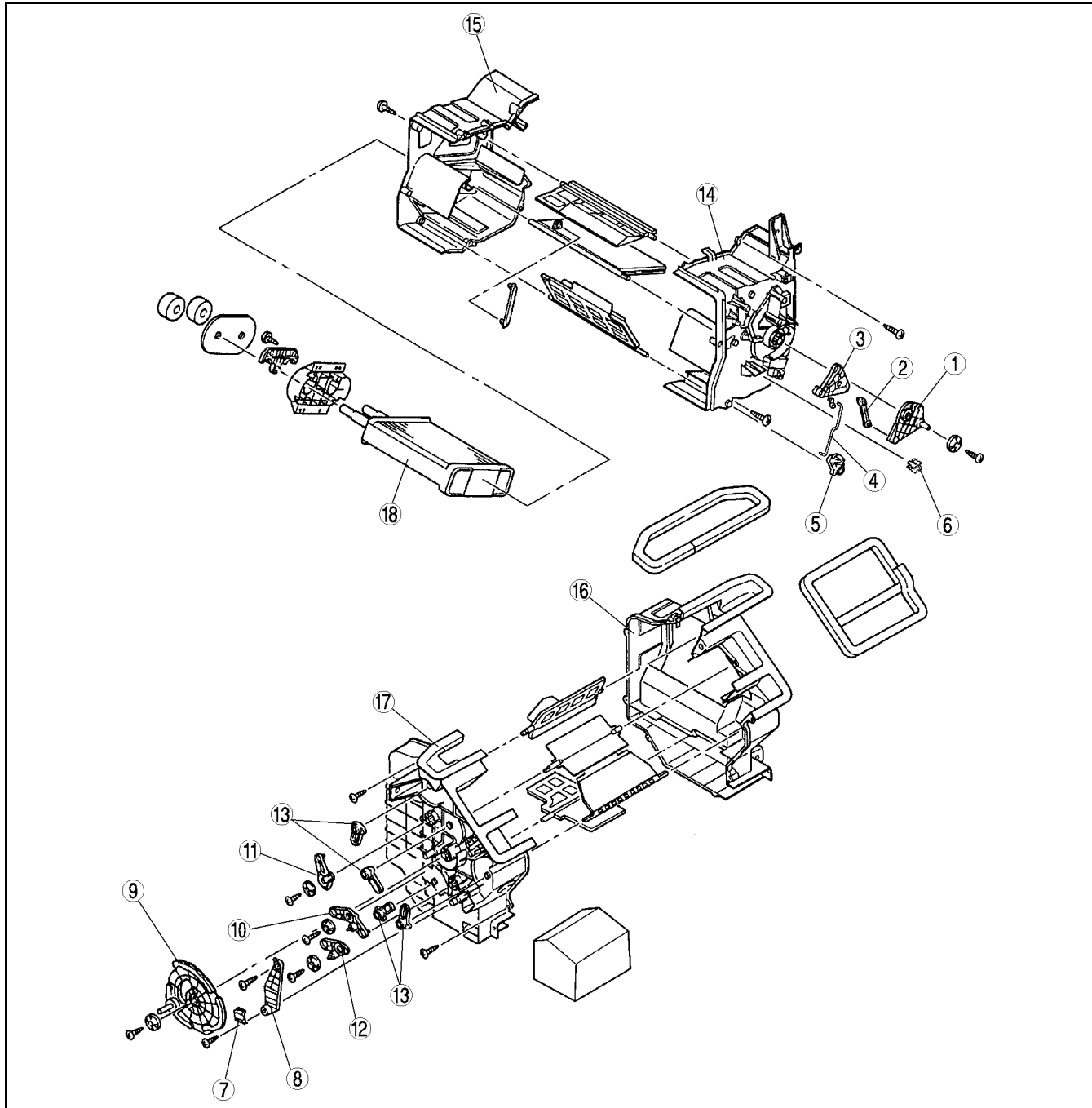

07-11

A3U0711W003

1	Air mix link
2	Air mix rod (2)
3	Air mix crank (1)
4	Air mix rod (1)
5	Air mix crank (2)
6	Wire clamp
7	Wire clamp
8	Bracket
9	Airflow mode main link (See 07-11-10 Airflow Mode Main Link Installation Note)

10	Airflow mode sub link (1)
11	Airflow mode sub link (2)
12	Airflow mode sub link (3)
13	Airflow mode crank
14	Heater case (1)
15	Heater case (2)
16	Heater case (3)
17	Heater case (4)
18	Heater core

# BASIC SYSTEM

## HEATER CORE INSPECTION

A3U071161910W01

1. Remove the heater unit. (See 07–11–7 HEATER UNIT REMOVAL/INSTALLATION.)
2. Remove the heater core from the heater unit.
3. Inspect for cracks, damage, and coolant leakage.
  - If any problems are found, replace the heater core.
4. Inspect for bent fins.
  - If any are bent, use a flathead screwdriver to straighten them.
5. Verify that the heater core inlet and outlet are not distorted or damaged. Repair with pliers if necessary.

## AIRFLOW MODE MAIN LINK REMOVAL/INSTALLATION

A3U071161030W01

1. Disconnect the airflow mode wire from the airflow mode main link.
2. Remove in the airflow mode main link. (See 07–11–10 Airflow Mode Main Link Installation Note)
3. Install in the reverse order of removal.
4. Adjust the airflow mode wire. (See 07–40–11 CLIMATE CONTROL UNIT WIRE ADJUSTMENT.)

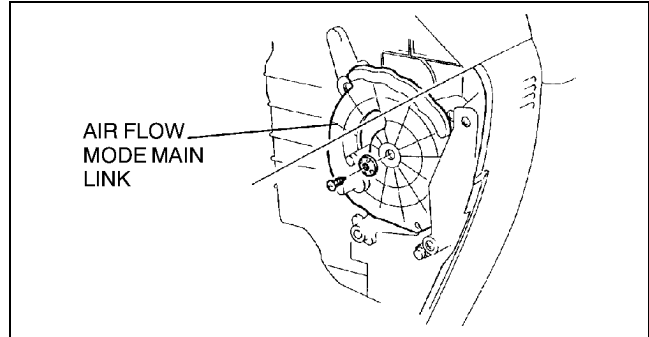

Z3U0711W024

### Airflow Mode Main Link Installation Note

#### Caution

- If any grease other than the specified grease is applied to the links, abnormal noise will occur or the links will not properly operate. Therefore, do not apply any grease to the links.

1. Push and hold each airflow mode sub link in the direction shown by the arrow.

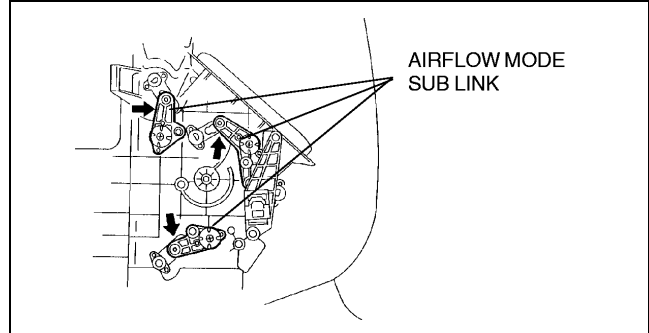

X3U711WAF

2. Set the airflow mode main link to the heater unit as shown in the figure.
3. Press the airflow mode main link lightly and rotate it in the direction shown by the arrow, then set the projections of each airflow mode sub link into the grooves of the airflow mode main link.
4. Rotate airflow mode main link and verify that each mode is accessed properly.

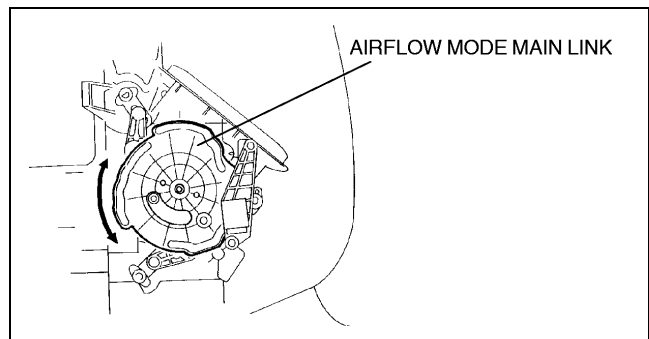

X3U711WAG

## BASIC SYSTEM

### REAR DUCT REMOVAL/INSTALLATION

A3U071161271W01

1. Remove the side wall.
2. Remove in the rear duct.
3. Install in the reverse order of removal.

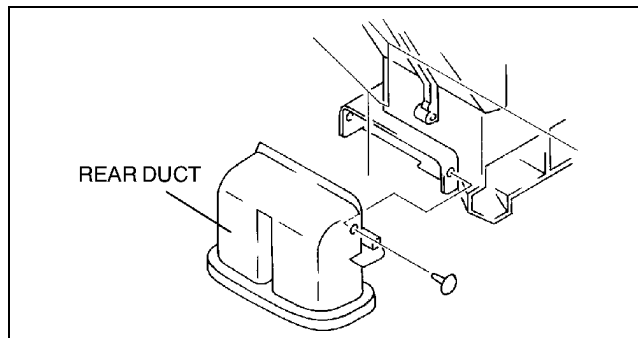

Z3U0711W025

### REAR HEAT DUCT REMOVAL/INSTALLATION

A3U071161273W01

1. Turn the floor covering over. (See 09-17-17 FLOOR COVERING REMOVAL/INSTALLATION.)
2. Remove in the order indicated in the table.

1	Rear heat duct (RH)
2	Rear heat duct (LH)

3. Install in the reverse order of removal.

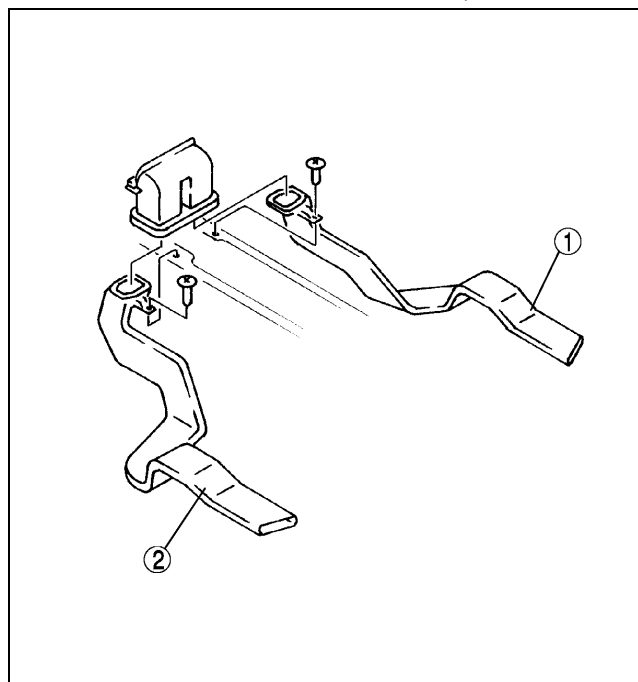

X3U711WAJ

### A/C COMPRESSOR REMOVAL/INSTALLATION

A3U071161450W01

1. Disconnect the negative battery cable.
2. Discharge the refrigerant from the system. (See 07-10-3 REFRIGERANT RECOVERY.) (See 07-10-3 REFRIGERANT CHARGING.)
3. Remove the splash shield (RH) and fresh-air duct.
4. Loosen the mounting bolts, nuts, and the adjusting lock bolt of the power steering oil pump.
5. Loosen the drive belt (P/S + A/C) and remove it. (See 01-10B-4 DRIVE BELT ADJUSTMENT [FS].)

#### Caution

- If moisture or foreign material enters the refrigeration cycle, cooling ability will be lowered and abnormal noise will occur. Always immediately plug open fittings after removing any refrigeration cycle parts to keep moisture or foreign material out of the cycle.

## BASIC SYSTEM

6. Remove in the order indicated in the table. Do not allow compressor oil to spill.

1	Cooler hose (HI) (See 07-11-16 Refrigerant Lines Installation Note)
2	Cooler hose (LO) (See 07-11-16 Refrigerant Lines Installation Note)
3	Connector
4	A/C compressor (See 07-11-12 A/C Compressor Installation Note)

7. Install in the reverse order of removal.  
 8. Adjust the drive belt (P/S + A/C). (See 01-10B-4 DRIVE BELT ADJUSTMENT [FS].)  
 9. Perform the refrigerant system performance test. (See 07-10-2 REFRIGERANT SYSTEM PERFORMANCE TEST.)

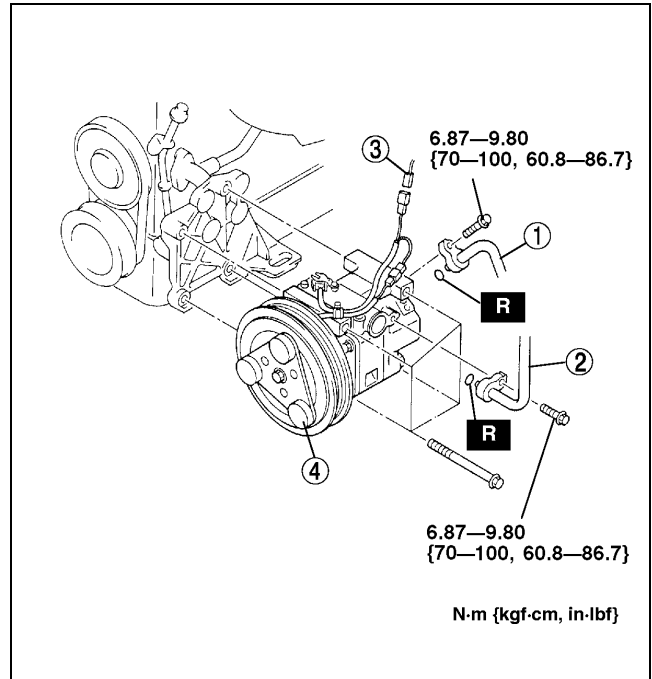

Y3U711WA1

### A/C Compressor Installation Note

1. Remove the following amount of compressor oil from the new A/C compressor when replacing the A/C compressor.

#### Compressor oil to be removed (approximate quantity)

**150 ml {150 cc, 5.07 fl oz} - [compressor oil from old A/C compressor + 15 ml {15 cc, 0.5 fl oz}]**

### CONDENSER REMOVAL/INSTALLATION

A3U071161480W01

1. Disconnect the negative battery cable.
2. Discharge the refrigerant from the system. (See 07-10-3 REFRIGERANT CHARGING.)
3. Pull up the coolant reservoir.
4. Remove the fresh-air duct, radiator bracket, air cleaner, resonance chamber, and mass airflow sensor connector.

#### Caution

- If moisture or foreign material enters the refrigeration cycle, cooling ability will be lowered and abnormal noise will occur. Always immediately plug all open fittings after removing any refrigeration cycle parts to keep moisture or foreign material out of the cycle.

#### Note

- Two kinds of condensers are used:
  - TYPE A (condenser without pipe)
  - TYPE B (condenser with pipe)

## BASIC SYSTEM

5. Remove in the order indicated in the table. Do not allow compressor oil to spill.

1	Cooler hose (H1) (See 07-11-16 Refrigerant Lines Installation Note)
2	Cooler pipe No.1 (type A) or outlet pipe of condenser (type B) (See 07-11-16 Refrigerant Lines Installation Note)
3	Condenser (See 07-11-13 Condenser Installation Note)

6. Install in the reverse order of removal.  
7. Perform the refrigerant system performance test.  
(See 07-10-2 REFRIGERANT SYSTEM PERFORMANCE TEST.)

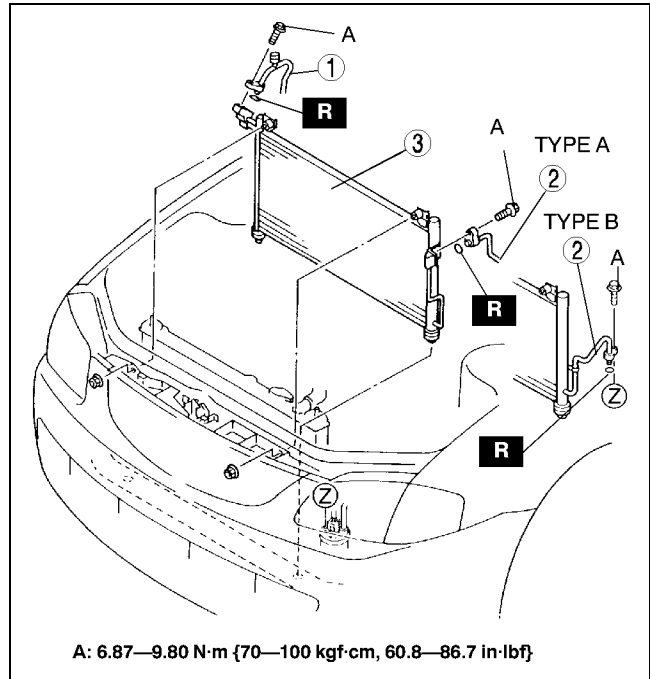

Z3U0711W016

07-11

### Condenser Installation Note

1. When installing a new condenser, add a supplemental amount of ATMOS GU10 compressor oil into the refrigeration cycle.

**Supplemental amount (approximate quantity)**  
**30 ml {30 cc, 1.0 fl oz}**

### CONDENSER INSPECTION

1. Inspect for cracks, damage, and oil leakage.
  - If any are found, replace the condenser.
2. Inspect for fins clogged by dust.
  - If any are clogged, remove the dust from the fins.
3. Inspect for bent fins.
  - If any are bent, use a flathead screwdriver to straighten them.

A3U071161480W02

### RECEIVER/DRIER REMOVAL/INSTALLATION

1. Disconnect the negative battery cable.
2. Discharge the refrigerant from the system. (See 07-10-3 REFRIGERANT RECOVERY.) (See 07-10-3 REFRIGERANT CHARGING.)
3. Pull up the coolant reservoir.
4. Remove the fresh-air duct, air cleaner, and resonance chamber.

A3U071161501W01

### Caution

- If moisture or foreign material enters the refrigeration cycle, cooling ability will be lowered and abnormal noise will occur. Always immediately plug all open fittings after removing any refrigeration cycle parts to keep moisture or foreign material out of the cycle.

## BASIC SYSTEM

5. Remove in the order indicated in the table. Do not allow compressor oil to spill.

1	Cooler pipe No.2 (See 07-11-16 Refrigerant Lines Installation Note)
2	Cooler pipe No.1 (type A) or outlet pipe of condenser (type B) (See 07-11-16 Refrigerant Lines Installation Note)
3	Connector
4	Receiver/drier (See 07-11-14 Receiver/drier Installation Note)

6. Install in the reverse order of removal.  
7. Perform the refrigerant system performance test.  
(See 07-10-2 REFRIGERANT SYSTEM PERFORMANCE TEST.)

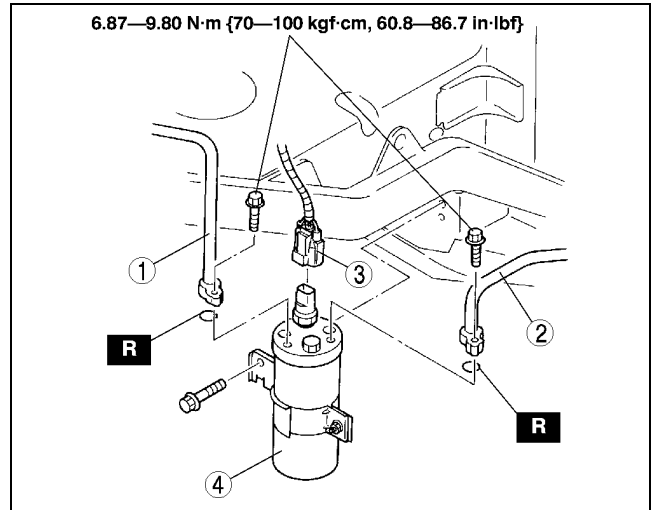

A3U0711W001

### Receiver/drier Installation Note

1. When installing a new receiver/drier, add a supplemental amount of ATMOS GU10 compressor oil into the refrigeration cycle.

**Supplemental amount (approximate quantity)**  
**10 ml {10 cc, 0.3 fl oz}**

### REFRIGERANT LINES REMOVAL/INSTALLATION

A3U071161460W01

1. Disconnect the negative battery cable.
2. Discharge the refrigerant from the system. (See 07-10-3 REFRIGERANT RECOVERY.) (See 07-10-3 REFRIGERANT CHARGING.)
3. Pull up the coolant reservoir.
4. Remove the fresh-air duct, radiator bracket, air cleaner, and resonance chamber.

#### Caution

- If moisture or foreign material enters the refrigeration cycle, cooling ability will be lowered and abnormal noise will occur. Always immediately plug all open fittings after removing any refrigeration cycle parts to keep moisture or foreign material out of the cycle.

5. Remove in the order indicated in the table. Do not allow compressor oil to spill.
6. Install in the reverse order of removal.

## BASIC SYSTEM

7. Perform the refrigerant system performance test. (See 07-10-2 REFRIGERANT SYSTEM PERFORMANCE TEST.)

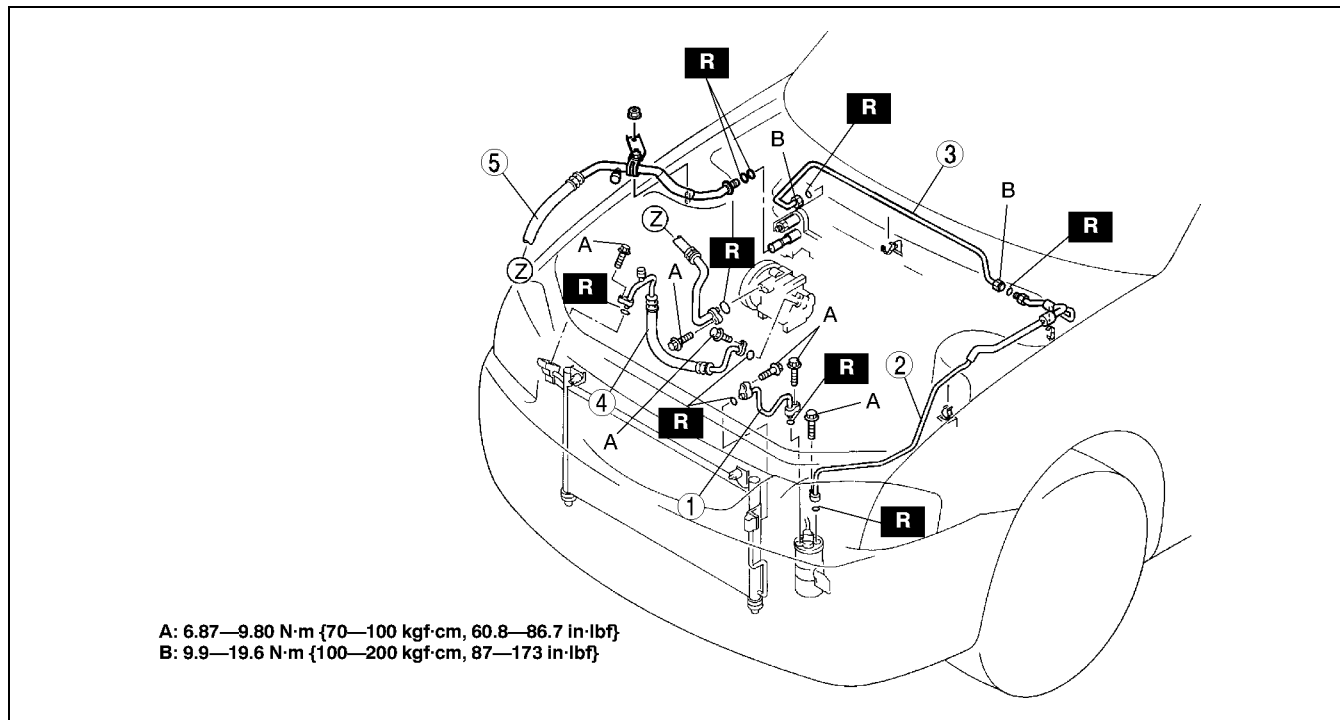

Z3U0711W018

1	Cooler pipe No.1 (type A only) (See 07-11-16 Refrigerant Lines Installation Note)
2	Cooler pipe No.2 (See 07-11-15 Refrigerant Lines Removal Note) (See 07-11-16 Refrigerant Lines Installation Note)
3	Cooler pipe No.3 (See 07-11-15 Refrigerant Lines Removal Note) (See 07-11-16 Refrigerant Lines Installation Note)

4	Cooler hose (HI) (See 07-11-16 Refrigerant Lines Installation Note)
5	Cooler hose (LO) (See 07-11-15 Refrigerant Lines Removal Note) (See 07-11-16 Refrigerant Lines Installation Note)

### Refrigerant Lines Removal Note

#### Nut joint type

- Loosen the nut using 2 spanners, then remove the cooler pipe or hose.

#### Spring-lock coupling type

- Set the SST.

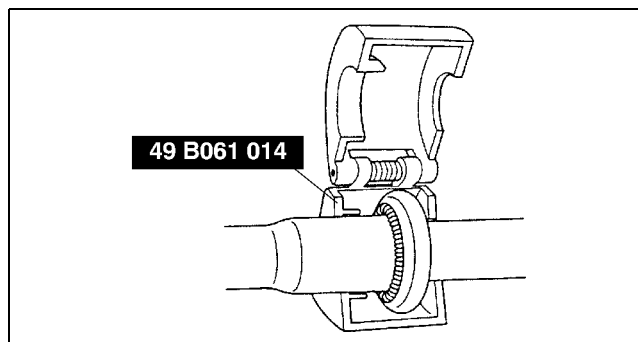

Z3U0711W019

## BASIC SYSTEM

2. While looking through the inspection hole of the **SST**, insert the protruding part of the **SST** until it makes contact with the gauge section.
3. Use the **SST** to disconnect the cooler hose (LO) from cooling unit by pulling the cooler hose (LO) side.

**Note**

- The cooler hose (LO) can be disconnected easily from cooling unit by pulling from the cooler hose (LO) while maintaining the pressure of the protruding part of the **SST**.

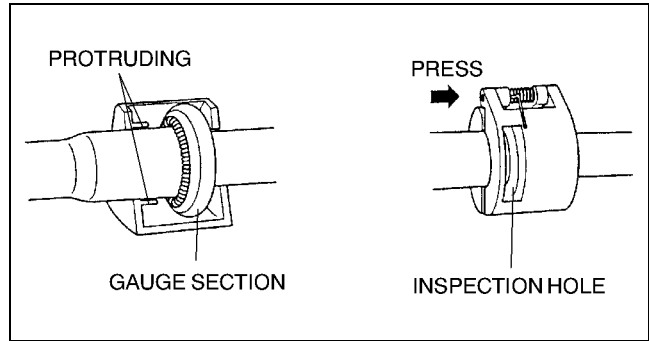

Z3U0711W020

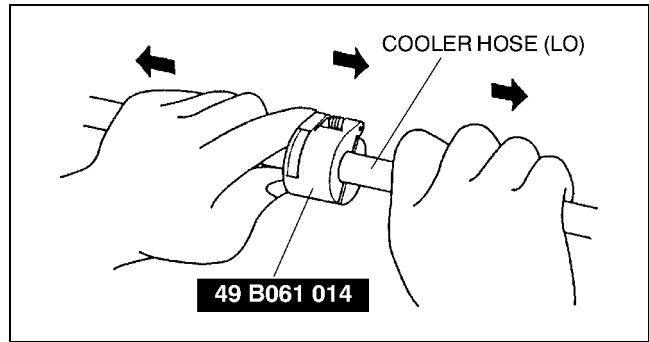

Z3U0711W021

**Refrigerant Lines Installation Note**

1. When installing a new cooler pipe or hose, add a supplemental amount of ATMOS GU10 compressor oil into the refrigeration cycle.

**Supplemental amount (approximate quantity)**

**5 ml {5 cc, 0.2 fl oz}**

2. Apply compressor oil to the O-rings and connect the joints.
3. Tighten the joints.

**Nut or block joint type**

1. Tighten the nut or bolt of the joint by hand.
2. Tighten the joint to the specified torque wrench.

**Spring-lock coupling type**

1. Connect the cooler hose (LO) by twisting it onto cooling unit until the garter spring at the cooler hose (LO) is over the flared end of cooling unit.

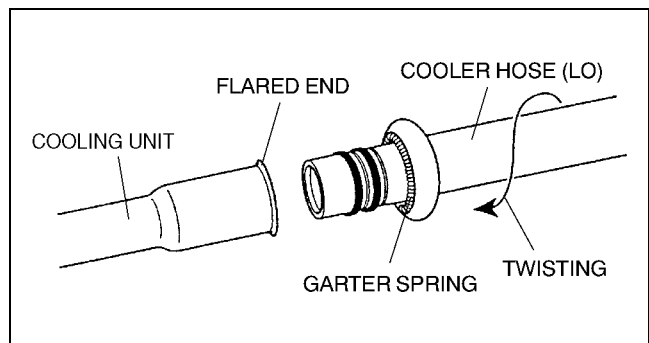

Z3U0711W022

**Note**

- When the cooler hose (LO) is replaced, the indicator ring comes out after connecting to indicate that it is locked.

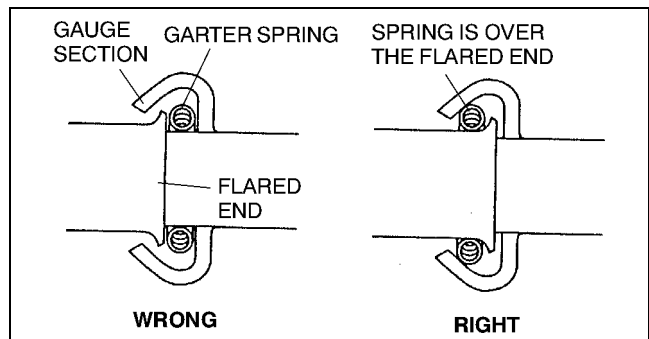

Z3U0711W023



**07-40 CONTROL SYSTEM**

**CONTROL SYSTEM LOCATION INDEX** 07-40-2  
System Wiring Diagram . . . . . 07-40-3  
**AIR INTAKE ACTUATOR**  
REMOVAL/INSTALLATION . . . . . 07-40-3  
**AIR INTAKE ACTUATOR INSPECTION** 07-40-4  
**BLOWER MOTOR**  
REMOVAL/INSTALLATION . . . . . 07-40-4  
**BLOWER MOTOR INSPECTION** . . . . . 07-40-5  
**CONDENSER FAN**  
REMOVAL/INSTALLATION . . . . . 07-40-5  
**CONDENSER FAN INSPECTION** . . . . . 07-40-5  
**RESISTOR REMOVAL/INSTALLATION** 07-40-6  
**RESISTOR INSPECTION** . . . . . 07-40-6  
**MAGNETIC CLUTCH**  
DISASSEMBLY/ASSEMBLY . . . . . 07-40-6  
Bolt Removal/Installation Note . . . . . 07-40-7  
Stator and Thermal Protector Removal  
Note . . . . . 07-40-7  
Stator and Thermal Protector Installation  
Note . . . . . 07-40-7  
Screw Installation Note . . . . . 07-40-7  
Clamp Installation Note . . . . . 07-40-7  
Snap Ring Installation Note . . . . . 07-40-7  
**MAGNETIC CLUTCH ADJUSTMENT** . . . 07-40-7

**MAGNETIC CLUTCH INSPECTION** . . . . 07-40-8  
**REFRIGERANT PRESSURE SWITCH**  
REMOVAL/INSTALLATION . . . . . 07-40-9  
Refrigerant Pressure Switch Installation  
Note . . . . . 07-40-9  
**REFRIGERANT PRESSURE SWITCH**  
INSPECTION . . . . . 07-40-9  
**CLIMATE CONTROL UNIT REMOVAL** . . 07-40-9  
**CLIMATE CONTROL UNIT**  
INSTALLATION . . . . . 07-40-10  
**CLIMATE CONTROL UNIT**  
DISASSEMBLY/ASSEMBLY . . . . . 07-40-10  
Wire Disassembly Note . . . . . 07-40-10  
Wire Assembly Note . . . . . 07-40-11  
**CLIMATE CONTROL UNIT WIRE**  
ADJUSTMENT . . . . . 07-40-11  
Air Mix Wire . . . . . 07-40-11  
Airflow Mode Wire . . . . . 07-40-11  
**CLIMATE CONTROL UNIT**  
INSPECTION . . . . . 07-40-11  
Terminal voltage list (Reference) . . . . 07-40-12  
Fan switch . . . . . 07-40-13  
**A/C AMPLIFIER INSPECTION** . . . . . 07-40-13  
Terminal Voltage List (Reference) . . . . 07-40-14

07-40

# CONTROL SYSTEM

## CONTROL SYSTEM LOCATION INDEX

A3U074001070W01

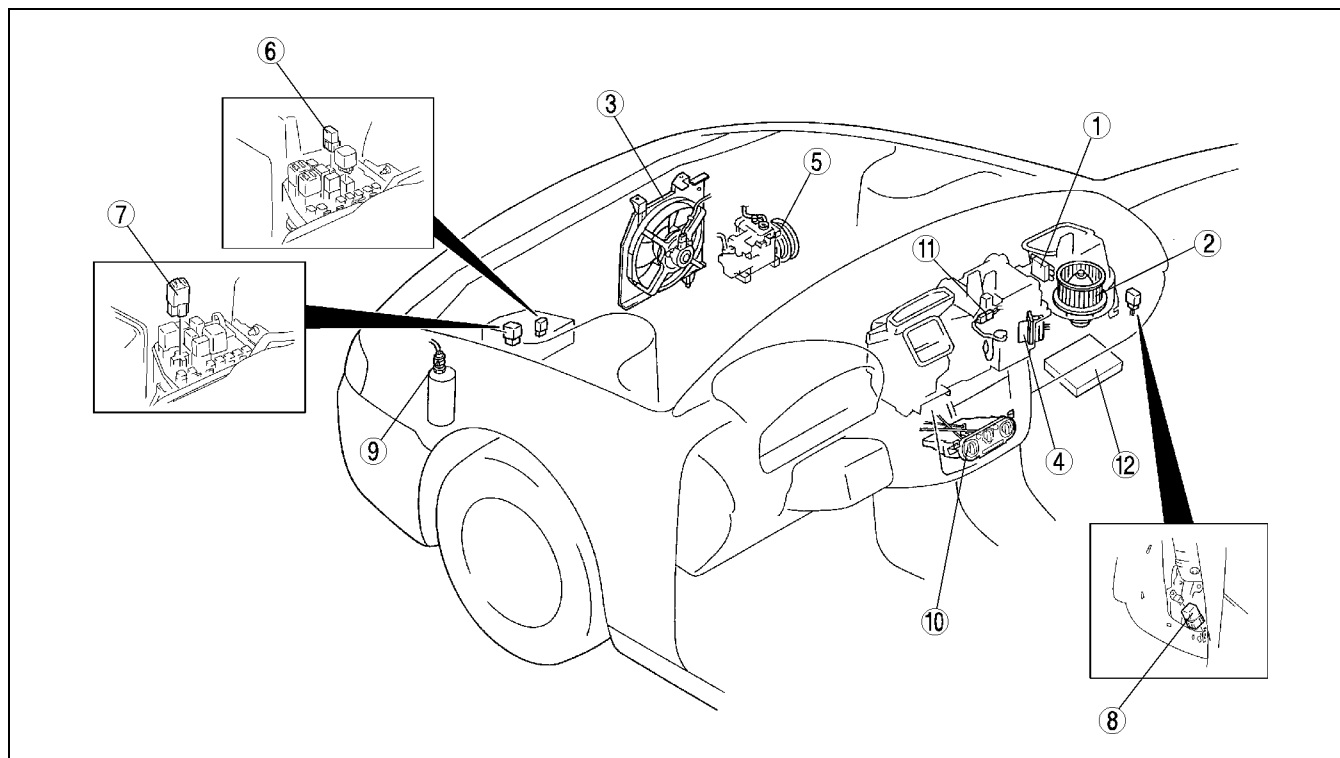

Z3U0740W001

1	Air intake actuator (See 07-40-3 AIR INTAKE ACTUATOR REMOVAL/INSTALLATION) (See 07-40-4 AIR INTAKE ACTUATOR INSPECTION)
2	Blower motor (See 07-40-4 BLOWER MOTOR REMOVAL/INSTALLATION) (See 07-40-5 BLOWER MOTOR INSPECTION)
3	Condenser fan (See 07-40-5 CONDENSER FAN REMOVAL/INSTALLATION) (See 07-40-5 CONDENSER FAN INSPECTION)
4	Resistor (See 07-40-6 RESISTOR REMOVAL/INSTALLATION) (See 07-40-6 RESISTOR INSPECTION)
5	Magnetic clutch (See 07-40-6 MAGNETIC CLUTCH DISASSEMBLY/ASSEMBLY) (See 07-40-7 MAGNETIC CLUTCH ADJUSTMENT) (See 07-40-8 MAGNETIC CLUTCH INSPECTION)
6	A/C relay (See 09-21-5 RELAY INSPECTION)

7	Condenser fan relay (See 09-21-5 RELAY INSPECTION)
8	Blower relay (See 09-21-5 RELAY INSPECTION)
9	Refrigerant pressure switch (See 07-40-9 REFRIGERANT PRESSURE SWITCH REMOVAL/INSTALLATION) (See 07-40-9 REFRIGERANT PRESSURE SWITCH INSPECTION)
10	Climate control unit (See 07-40-9 CLIMATE CONTROL UNIT REMOVAL) (See 07-40-10 CLIMATE CONTROL UNIT INSTALLATION) (See 07-40-10 CLIMATE CONTROL UNIT DISASSEMBLY/ASSEMBLY) (See 07-40-11 CLIMATE CONTROL UNIT INSPECTION)
11	A/C amplifier (See 07-40-13 A/C AMPLIFIER INSPECTION)
12	PCM (See 01-40B-7 PCM REMOVAL/INSTALLATION [FS]) (See 01-40A-7 PCM REMOVAL/INSTALLATION [ZM]) (See 01-40B-7 PCM INSPECTION [FS]) (See 01-40A-7 PCM INSPECTION [ZM])

# CONTROL SYSTEM

## System Wiring Diagram

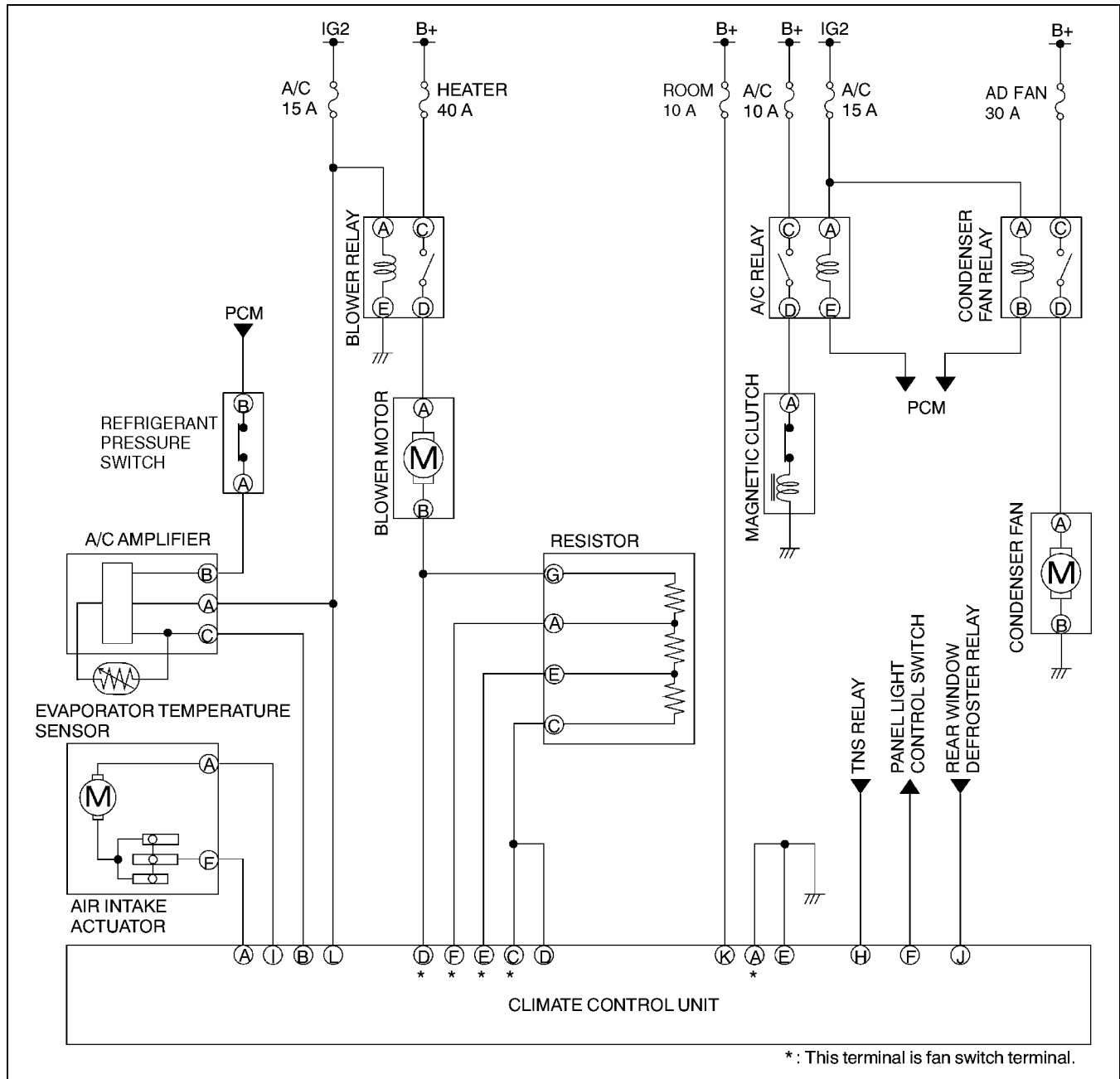

Z3U0740W002

### AIR INTAKE ACTUATOR REMOVAL/INSTALLATION

A3U074061060W01

1. Disconnect the negative battery cable.
2. Remove the cooling unit. (See 07-11-3 COOLING UNIT REMOVAL/INSTALLATION.)
3. Remove in the order indicated in the table.

1	Connector
2	Air intake actuator

4. Install in the reverse order of removal.

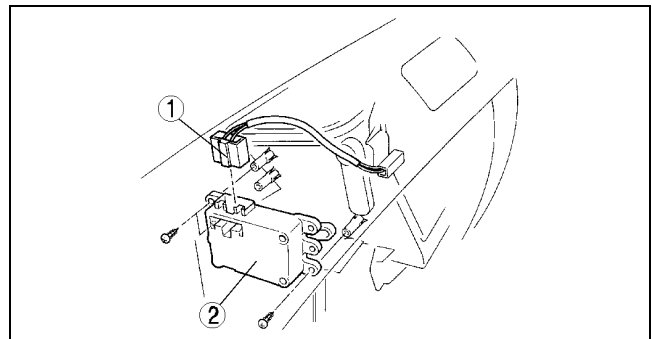

Z3U0740W003

# CONTROL SYSTEM

## AIR INTAKE ACTUATOR INSPECTION

A3U074061060W02

1. Remove the air intake actuator. (See 07-40-3 AIR INTAKE ACTUATOR REMOVAL/INSTALLATION.)
2. Connect B+ to terminal A or F and ground to terminal F or A of the air intake actuator.
3. Verify that the air intake actuator operates as shown below.

Connection		Movement
B+	GND	
A	F	FRESH → RECIRCULATE
F	A	RECIRCULATE → FRESH

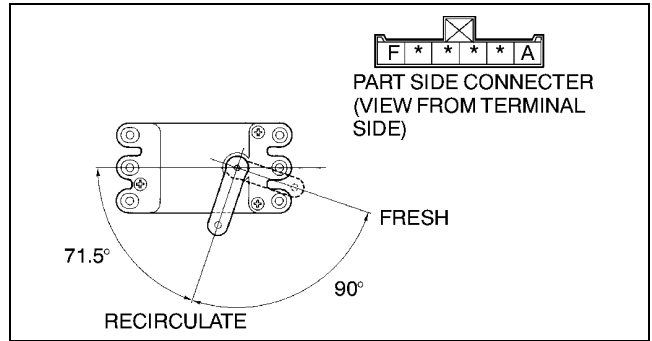

Z3U0740W004

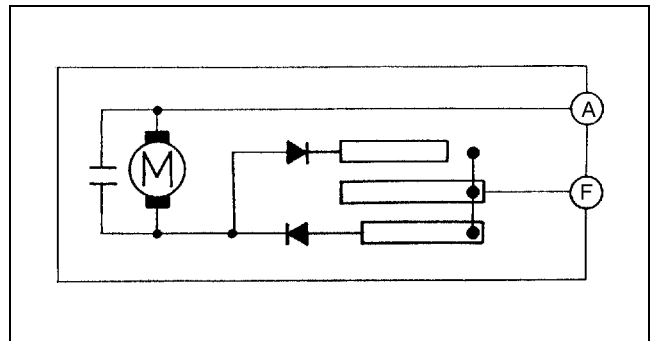

Z3U0740W005

## BLOWER MOTOR REMOVAL/INSTALLATION

A3U074061020W01

1. Disconnect the negative battery cable.
2. Remove the glove compartment.
3. Remove in the order indicated in the table.

1	Connector
2	Blower motor

4. Install in the reverse order of removal.

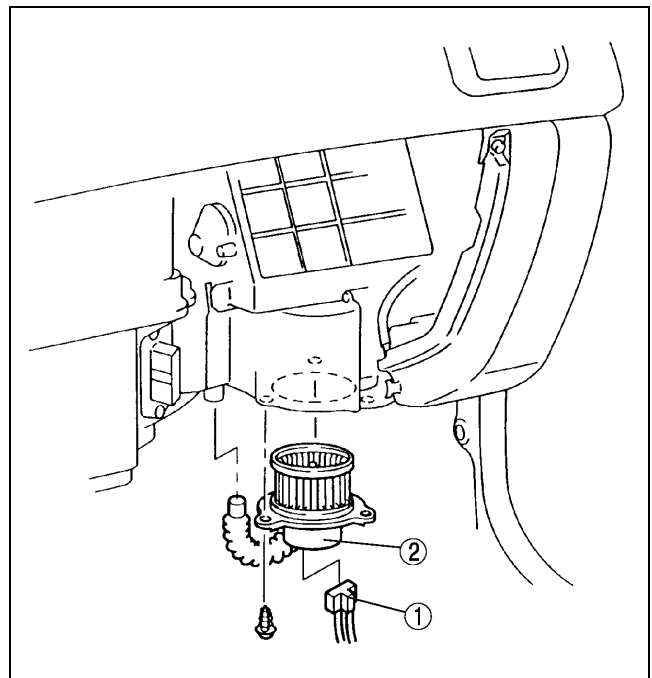

X3U740WA1

# CONTROL SYSTEM

## BLOWER MOTOR INSPECTION

A3U074061020W02

1. Disconnect the blower motor connector.
2. Connect B+ to terminal A and ground to terminal B of the blower motor and verify its operation.
  - If not as specified, replace the blower motor.

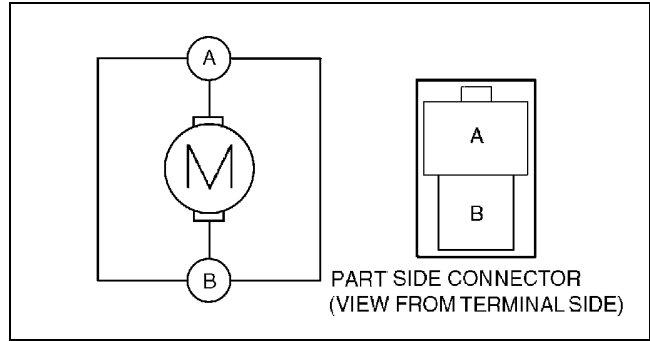

Y3U740WA0

## CONDENSER FAN REMOVAL/INSTALLATION

A3U074061710W01

1. Disconnect the negative battery cable.
2. Remove the fresh-air duct.
3. Remove in the order indicated in the table.

1	Connector
2	Condenser fan

4. Install in the reverse order of removal.

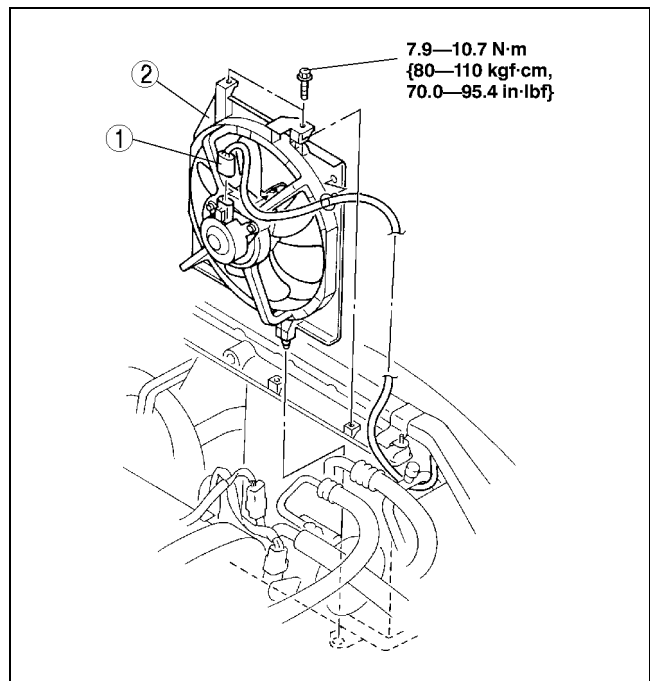

Z3U0740W006

## CONDENSER FAN INSPECTION

A3U074061710W02

1. Disconnect the condenser fan connector.
2. Connect B+ to terminal A and ground to terminal B of the condenser fan and verify its operation.
  - If not as specified, replace the condenser fan.

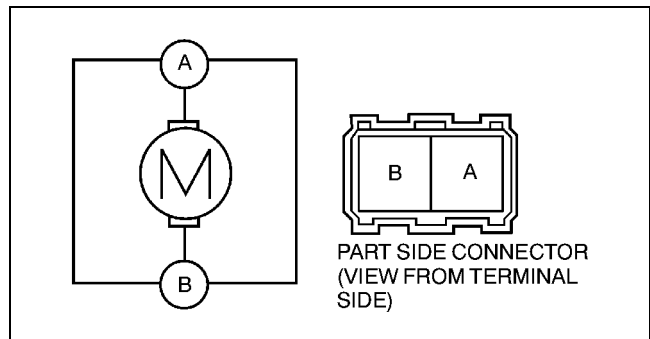

Z3U0740W007

# CONTROL SYSTEM

## RESISTOR REMOVAL/INSTALLATION

A3U074061015W01

1. Disconnect the negative battery cable.
2. Remove the glove compartment.
3. Remove in the order indicated in the table.

1	Connector
2	Resistor

4. Install in the reverse order of removal.

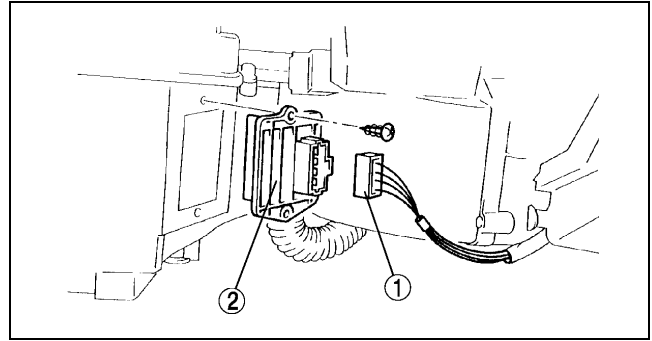

X3U740WA5

## RESISTOR INSPECTION

A3U074061015W02

1. Remove the glove compartment.
2. Disconnect the resistor connector.
3. Verify that the resistance between the terminals of the resistor is as indicated in the table.

Terminal	Resistance (ohm)
G-A	0.17—0.19
G-E	0.51—0.58
G-C	2.35—2.70

- If not as specified, replace the resistor.

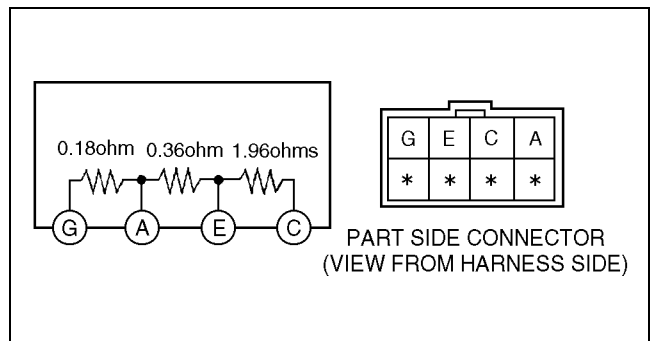

Z6E8540W002

## MAGNETIC CLUTCH DISASSEMBLY/ASSEMBLY

A3U074061010W01

1. Disassemble in the order indicated in the table.

1	Bolt (See 07-40-7 Bolt Removal/Installation Note)
2	Pressure plate
3	Shim
4	Snap ring (See 07-40-7 Snap Ring Installation Note)
5	A/C compressor pulley
6	Screw (See 07-40-7 Screw Installation Note)
7	Clip
8	Screw (See 07-40-7 Screw Installation Note)
9	Clamp (See 07-40-7 Clamp Installation Note)
10	Screw (See 07-40-7 Screw Installation Note)
11	Stator and thermal protector (See 07-40-7 Stator and Thermal Protector Removal Note) (See 07-40-7 Stator and Thermal Protector Installation Note)
12	A/C compressor body

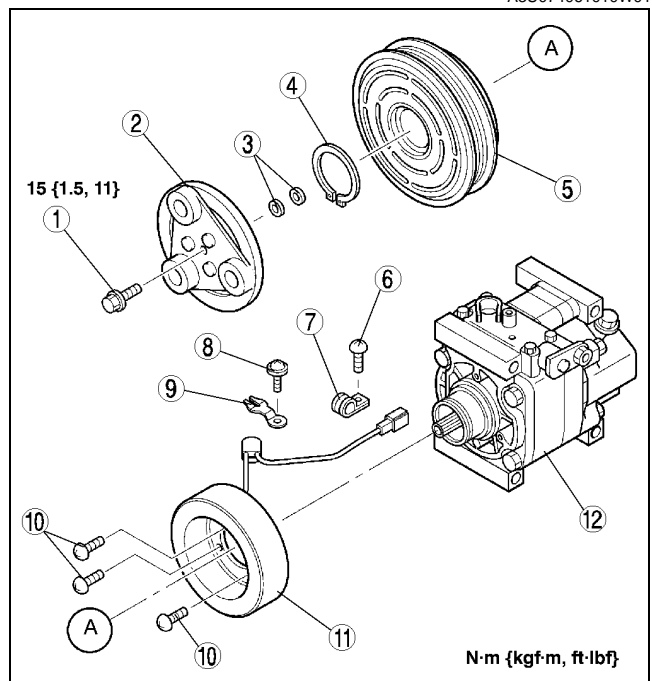

Z3U0740W009

2. Assemble in the reverse order of disassembly.
3. Adjust the magnetic clutch clearance. (See 07-40-7 MAGNETIC CLUTCH ADJUSTMENT.)

## CONTROL SYSTEM

### Bolt Removal/Installation Note

1. When removing or installing the bolt, hold the pressure plate in place as shown in the figure.
2. When installing a new A/C compressor body, replace the bolt.

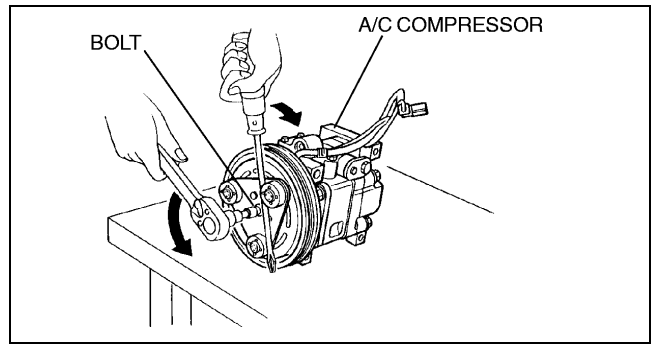

X3U740WA8

### Stator and Thermal Protector Removal Note

1. After removing the thermal protector, completely remove the silicone adhering to the A/C compressor side.

### Stator and Thermal Protector Installation Note

1. Apply **approximately 1 g {0.04 oz}** of silicone (Shin-Etsu Silicone KE-347W or similar)

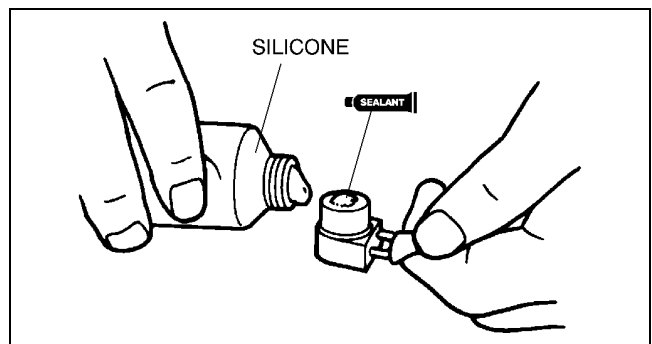

Z3U0740W010

07-40

### Screw Installation Note

1. When installing a new stator and thermal protector, replace the screw.

### Clamp Installation Note

1. When installing a new stator and thermal protector, replace the clamp.

### Snap Ring Installation Note

1. When installing a new pressure plate, A/C compressor pulley, stator and thermal protector, or A/C compressor body, replace the snap ring.

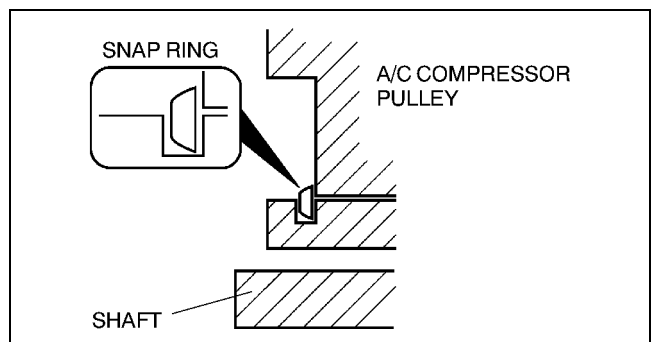

Z3U0740W011

### MAGNETIC CLUTCH ADJUSTMENT

1. Set the A/C compressor on a level block.
2. Turn on the magnetic clutch by connecting the B+ to the magnetic clutch connector terminal and the ground to the A/C compressor body.

A3U074061010W02

## CONTROL SYSTEM

3. Fix a dial gauge on a magnetic base and set the measuring probe onto point A on the pressure plate surface.
4. Turn off the magnetic clutch by disconnecting the ground from the A/C compressor body, then measure the dial gauge readings.

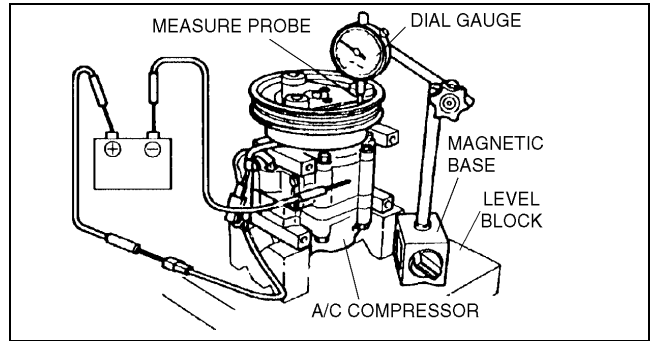

X3U740WA9

5. Measure the clearance for points B and C on the pressure plate surface by repeating the above Steps 2 through 4.

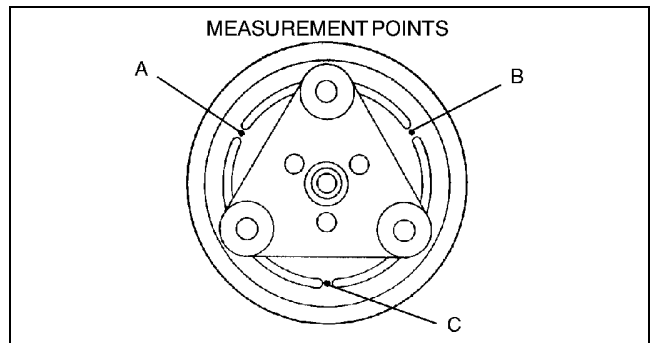

Z3U0740W020

6. Verify that the clearance is within the specification.
  - If not within the specification, remove the pressure plate and adjust the clearance by changing the shim (**0.2 mm {0.008 in}**, **0.5 mm {0.02 in}**) or the number of shims. (See 07-40-6 MAGNETIC CLUTCH DISASSEMBLY/ASSEMBLY.)

### Clearance

0.4—0.6 mm {0.016—0.023 in}

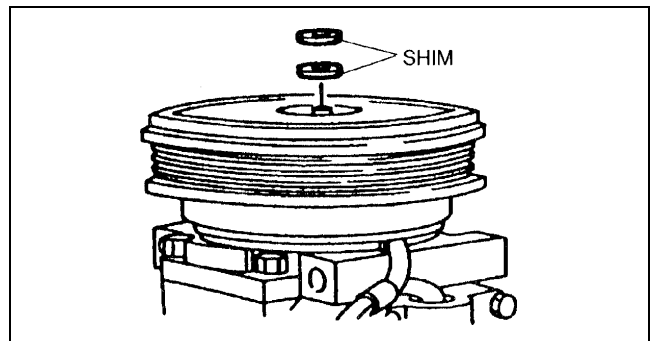

X3U740WAB

A3U074061010W03

## MAGNETIC CLUTCH INSPECTION

1. Disconnect the magnetic clutch connector.
2. Connect B+ to terminal A of magnetic clutch and ground to the A/C compressor body.
3. Verify that the magnetic clutch operates.
  - If not as specified, replace the stator and thermal protector.

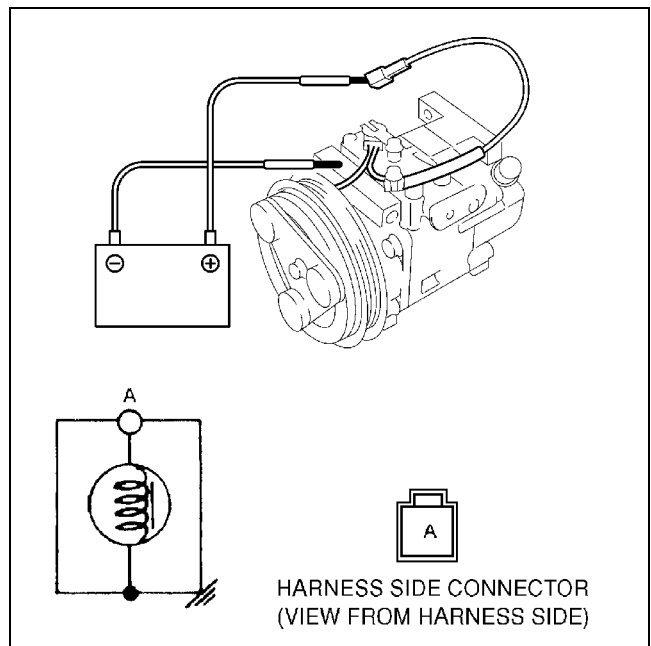

Z3U0740W012



# CONTROL SYSTEM

## REFRIGERANT PRESSURE SWITCH REMOVAL/INSTALLATION

A3U074061503W01

1. Disconnect the negative battery cable.
2. Remove the receiver/drier. (See 07-11-13 RECEIVER/DRIER REMOVAL/INSTALLATION.)
3. Remove the refrigerant pressure switch. (See 07-40-9 Refrigerant Pressure Switch Installation Note)
4. Install in the reverse order of removal.

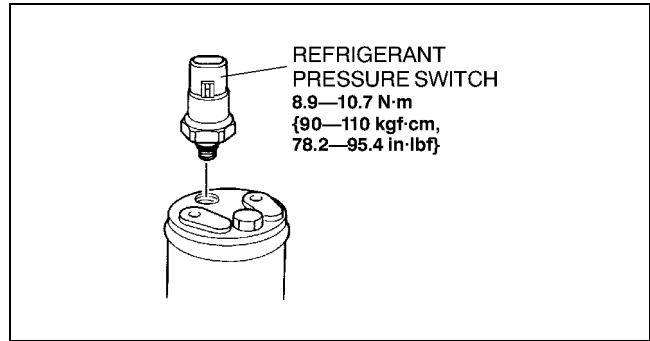

A3U0740W001

### Refrigerant Pressure Switch Installation Note

1. Apply compressor oil to the O-ring and connect the joint.

## REFRIGERANT PRESSURE SWITCH INSPECTION

A3U074061503W02

1. Install the manifold gauge set.
2. Disconnect the refrigerant pressure switch connector.
3. Verify the high-pressure side reading of the manifold gauge and continuity between the terminals of the refrigerant pressure switch.
  - If not as specified, replace the refrigerant pressure switch.

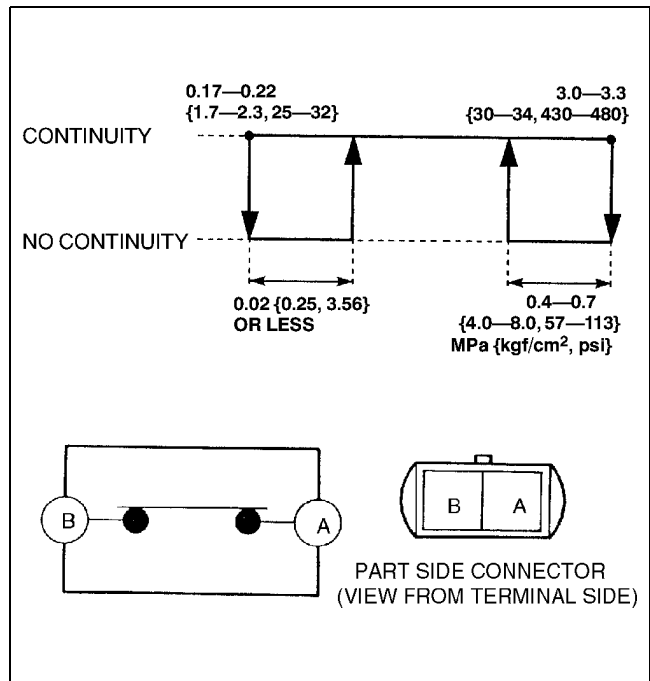

Z3U0740W014

## CLIMATE CONTROL UNIT REMOVAL

A3U074061190W01

1. Disconnect the negative battery cable.
2. Disconnect the air mix and airflow mode wires from each wire clamp and link.
3. Remove the center panel. (See 09-17-4 CENTER PANEL REMOVAL/INSTALLATION.)
4. Remove the screws and the climate control unit.

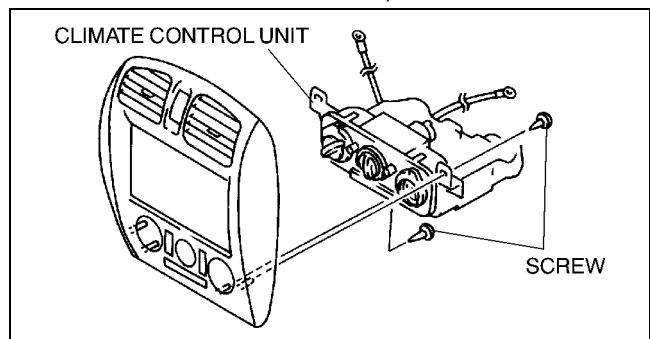

Z3U0740W015

# CONTROL SYSTEM

## CLIMATE CONTROL UNIT INSTALLATION

A3U074061190W02

1. Install the climate control unit to the center panel.
2. Pass each wire through the following routes then connect to each unit.
3. Connect the climate control unit connectors.
4. Install the center panel.
5. Adjust the climate control unit wire. (See 07-40-11 CLIMATE CONTROL UNIT WIRE ADJUSTMENT.)
6. Connect the negative battery cable.

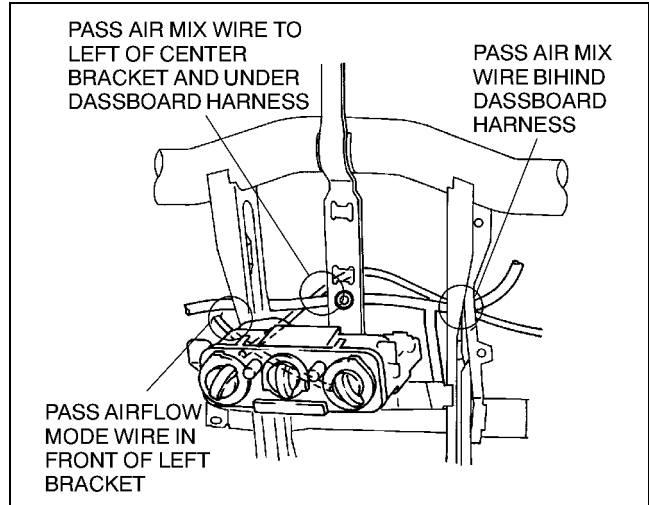

Z3U0740W016

## CLIMATE CONTROL UNIT DISASSEMBLY/ASSEMBLY

A3U074061190W03

1. Disassemble in the order indicated in the table.

1	Dial
2	Knob
3	Panel
4	Fan switch
5	Illumination bulb
6	Air mix wire (See 07-40-10 Wire Disassembly Note) (See 07-40-11 Wire Assembly Note)
7	Airflow mode wire (See 07-40-10 Wire Disassembly Note) (See 07-40-11 Wire Assembly Note)
8	Body

2. Assemble in the reverse order of disassembly.

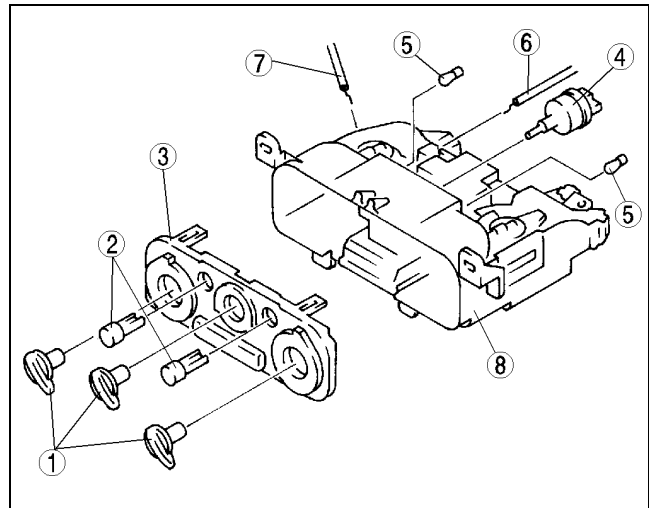

Y3E8540W028

### Wire Disassembly Note

1. Disassemble the wires in the order indicated in the table.

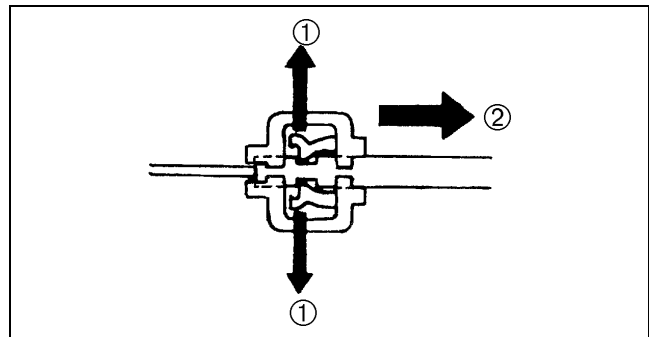

X3U740WAX

# CONTROL SYSTEM

## Wire Assembly Note

1. Assemble the wires in the order indicated in the table.

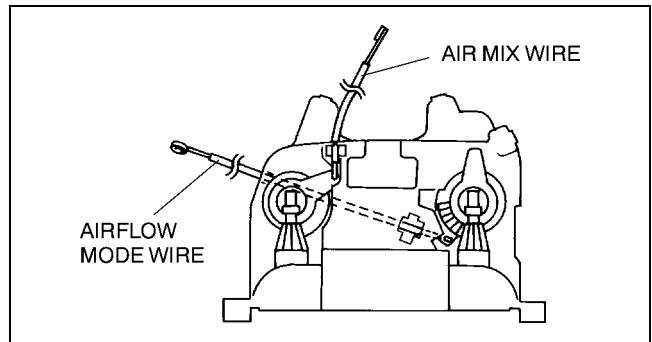

Z3U0740W018

## CLIMATE CONTROL UNIT WIRE ADJUSTMENT

### Air Mix Wire

1. Set the temperature control dial at max cold.
2. Set the air mix link to max cold in the direction shown by the arrow and insert a screwdriver at the set hole.
3. Connect the air mix wire to air mix link.
4. Clamp the air mix wire to wire clamp.
5. Verify that the temperature control dial moves its full stroke.

A3U074061190W04

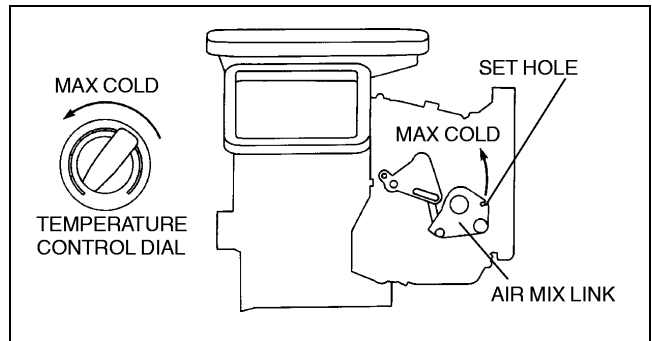

X3U740WB0

### Airflow Mode Wire

1. Set the airflow mode control dial at defroster.
2. Set the airflow mode main link to defroster in the direction shown by the arrow and insert a screwdriver at the set hole.
3. Connect the airflow mode wire to airflow mode main link.
4. Clamp the airflow mode wire to wire clamp.
5. Verify that the airflow mode control dial moves its full stroke.

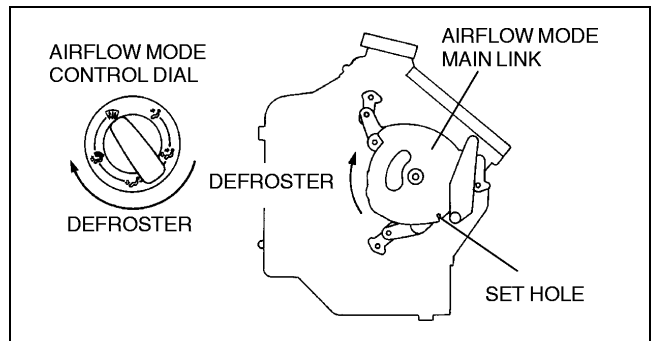

X3U740WB1

## CLIMATE CONTROL UNIT INSPECTION

1. Remove the climate control unit.
2. Connect the climate control unit connector.
3. Turn the ignition switch to ON position.
4. Measure the voltage at each climate control unit terminal and refer to the terminal voltage list.
  - If not as specified, inspect the parts listed under "Action" and the related wiring harness.
    - If there is any malfunction, replace the climate control unit.

A3U074061190W05

# CONTROL SYSTEM

## Terminal voltage list (Reference)

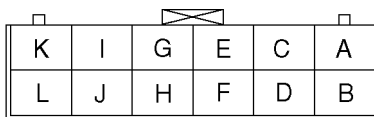

PART SIDE CONNECTOR  
(VIEW FROM HARNESS SIDE)

Y3E8540W027

Terminal	Signal	Connected to	Test condition	Voltage (V)	Action
A	Fresh signal	Air intake actuator	RECIRCULATE	0.3	<ul style="list-style-type: none"> <li>Inspect air intake actuator</li> <li>Inspect related harness</li> </ul>
			FRESH	11.3	
B	A/C signal	A/C amplifier	Fan switch ON, A/C switch ON	1.45	<ul style="list-style-type: none"> <li>Inspect for continuity or short circuit (Climate control unit—A/C amplifier: B—C)</li> <li>Inspect A/C amplifier</li> </ul>
			Fan switch OFF	10.3	
C	—	—	—	—	—
D	A/C signal	Fan switch	Fan switch OFF	B+	<ul style="list-style-type: none"> <li>Inspect for continuity or short circuit (Climate control unit—Fan switch, Resistor: D—C, C)</li> <li>Inspect fan switch</li> <li>Inspect resistor</li> <li>Inspect related harness</li> </ul>
			Fan switch 1st	0.12	
			Fan switch 2nd	0.65	
			Fan switch 3rd	0.60	
			Fan switch 4th	0.30	
E	GND	Ground	Under any condition	Below 1.0	<ul style="list-style-type: none"> <li>Inspect for continuity (A/C amplifier—Ground: E—GND)</li> <li>Inspect related harness</li> </ul>
F	TNS signal	Panel light control switch	Light switch ON and panel light control switch at max. illumination	0.2	<ul style="list-style-type: none"> <li>Inspect for continuity or short circuit (Climate control unit—Panel light control switch: F—C)</li> <li>Inspect panel light control switch</li> <li>Inspect related harness</li> </ul>
			Light switch ON and panel light control switch at min. illumination	9.7	
			Light switch OFF	0.1	
G	—	—	—	—	—
H	TNS signal	TNS relay	Light switch ON	B+	<ul style="list-style-type: none"> <li>Inspect for continuity or short circuit (Climate control unit—TNS relay: H—C)</li> <li>Inspect TNS relay</li> <li>Inspect headlight switch</li> <li>Inspect related harness</li> </ul>
			Light switch OFF	Below 1.0	<ul style="list-style-type: none"> <li>Inspect for short circuit (Climate control unit—TNS relay: H—C)</li> <li>Inspect TNS relay</li> <li>Inspect headlight switch</li> </ul>
I	Recirculate signal	Air intake actuator	RECIRCULATE	11.3	<ul style="list-style-type: none"> <li>Inspect air intake actuator</li> <li>Inspect related harness</li> </ul>
			FRESH	0.3	
J	Rear window defroster relay control signal	Rear window defroster relay	Rear window defroster switch ON	0.1	<ul style="list-style-type: none"> <li>Inspect for continuity or short circuit (Climate control unit—Rear window defroster relay: J—E)</li> <li>Inspect rear window defroster relay</li> <li>Inspect related harness</li> </ul>
			Rear window defroster switch OFF	B+	
K	Power supply	ROOM 10 A fuse	Under any condition	B+	<ul style="list-style-type: none"> <li>Inspect ROOM 10 A fuse</li> <li>Inspect related harness</li> </ul>

# CONTROL SYSTEM

Terminal	Signal	Connected to	Test condition	Voltage (V)	Action
L	IG2	A/C 15 A fuse	Ignition switch at ON position	B+	<ul style="list-style-type: none"> <li>Inspect for continuity (Climate control unit—Fuse: L—A/C 15 A fuse)</li> <li>Inspect A/C 15 A fuse</li> <li>Inspect related harness</li> </ul>
			Ignition switch at LOCK position	0.1	<ul style="list-style-type: none"> <li>Inspect for short circuit (Climate control unit—Fuse: L—A/C 15 A fuse)</li> </ul>

## Fan switch

- Remove the climate control unit.
- Inspect for continuity between the fan switch terminals using an ohmmeter.

○—○ : Continuity

Switch position	Terminal				
	A	C	E	F	D
0					
1	○—○				
2	○—○		○—○		
3	○—○			○—○	
4	○—○				○—○

Y3E8540W026

- If not as specified, replace the fan switch.

## A/C AMPLIFIER INSPECTION

A3U074061790W01

### Note

- A/C amplifier controls A/C signal as shown in the figure at right.

- Remove the glove compartment.
- Pull out the A/C amplifier with the connector still connected.
- Turn the ignition switch to ON position.
- Measure the voltage at each A/C amplifier terminal or climate control unit terminal and refer to the terminal voltage list.
  - If not as specified, inspect the parts listed under "Action" and the related wiring harness.
  - If there is no malfunction under "Action", replace the A/C amplifier.

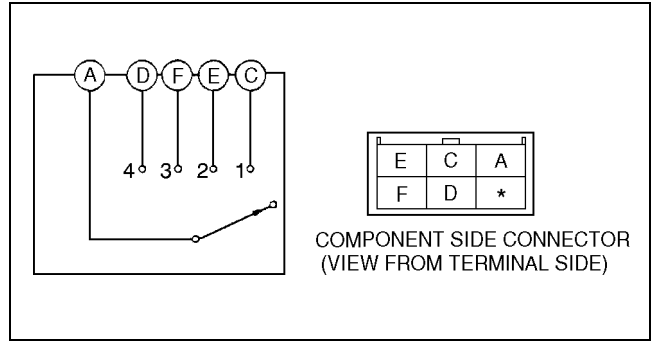

Y3E8540W025

07-40

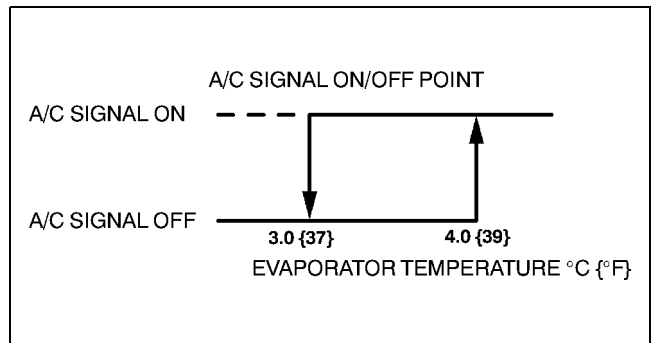

Z3U0740W019

# CONTROL SYSTEM

## Terminal Voltage List (Reference)

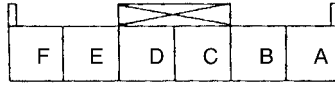

PART SIDE CONNECTOR  
(VIEW FROM HARNESS SIDE)

Y3E8540W024

Terminal	Signal	Connected to	Test condition	Voltage (V)	Action
A	IG2	A/C 15 A fuse	Ignition switch at ON position	B+	<ul style="list-style-type: none"> <li>Inspect for continuity or short circuit (Fuse —A/C amplifier:A/C 15 A fuse —A)</li> <li>Inspect A/C 15 A fuse</li> <li>Inspect related harness</li> </ul>
			Ignition switch at LOCK position	Below 1.0	
B	A/C signal	Refrigerant pressure switch	Fan switch at 1st position, A/C switch ON	0.6	<ul style="list-style-type: none"> <li>Inspect for continuity or short circuit (PCM—Refrigerant pressure switch:4F—B) (Refrigerant pressure switch—A/C amplifier:A—B)</li> <li>Inspect terminal voltage of A/C amplifier (C)</li> <li>Inspect refrigerant pressure switch</li> <li>Inspect PCM (See 01–40B–7 PCM INSPECTION [FS] ) (See 01–40A–7 PCM INSPECTION [ZM] )</li> <li>Inspect related harness</li> </ul>
			Fan switch OFF	12	
C	A/C switch	A/C switch	Fan switch OFF	11.5	<ul style="list-style-type: none"> <li>Inspect for short circuit (A/C amplifier—climate control unit: C—B)</li> <li>Inspect terminal voltage of A/C amplifier (A)</li> </ul>
			Fan switch at 1st position, A/C switch ON	0.6	
D	—	—	—	—	—
E	—	—	—	—	—
F	—	—	—	—	—

# 07-50 TECHNICAL DATA

HVAC TECHNICAL DATA ..... 07-50-1

## HVAC TECHNICAL DATA

A3U075001038W01

Item		Specification	
<b>REFRIGERANT SYSTEM</b>			
Refrigerant	Type	R-134a	
	Regular amount (approximate quantity) (g {oz})	600 {21.2}	
<b>BASIC SYSTEM</b>			
A/C compressor	Lubricating oil	Type	ATMOS GU10
		Sealed volume (approximate quantity) (ml {cc, fl oz}/rev)	150 {150, 5.07}
<b>CONTROL SYSTEM</b>			
Magnetic clutch	Clearance (mm {in})	0.4—0.6 {0.016—0.023}	

07-50

**07-60 SERVICE TOOLS**

HVAC SST..... 07-60-1

**HVAC SST**

A3U076001038W01

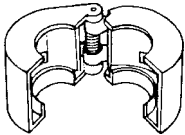
<p>49 B061 014</p> <p>Spring lock coupling disconnect tool</p> 	<p>—</p>	<p>—</p>
--	----------	----------



# RESTRAINTS

**08**  
SECTION

---

ON-BOARD DIAGNOSTIC . . . . .	08-02	AIR BAG SYSTEM . . . . .	08-10
SYMPTOM		SEAT BELT . . . . .	08-11
TROUBLESHOOTING . . . . .	08-03	SERVICE TOOLS . . . . .	08-60

---

## 08-02 ON-BOARD DIAGNOSTIC

AIR BAG SYSTEM WIRING DIAGRAM. . . . .	08-02-2	DTC 11 . . . . .	08-02-13
FOREWORD . . . . .	08-02-2	DTC 12 . . . . .	08-02-15
Flowchart . . . . .	08-02-2	DTC 22 . . . . .	08-02-17
Post-repair Operation . . . . .	08-02-4	DTC 25 . . . . .	08-02-20
DTC TABLE . . . . .	08-02-4	DTC 26 . . . . .	08-02-22
DTC 01 . . . . .	08-02-6	DTC 32 . . . . .	08-02-25
DTC 02 . . . . .	08-02-7	DTC 35 . . . . .	08-02-28
DTC 03 . . . . .	08-02-8	DTC 37 . . . . .	08-02-30
DTC 06 . . . . .	08-02-9	DTC 91 . . . . .	08-02-33
DTC 07 . . . . .	08-02-12		

---

08-02

# ON-BOARD DIAGNOSTIC

## AIR BAG SYSTEM WIRING DIAGRAM

A3U080201046W01

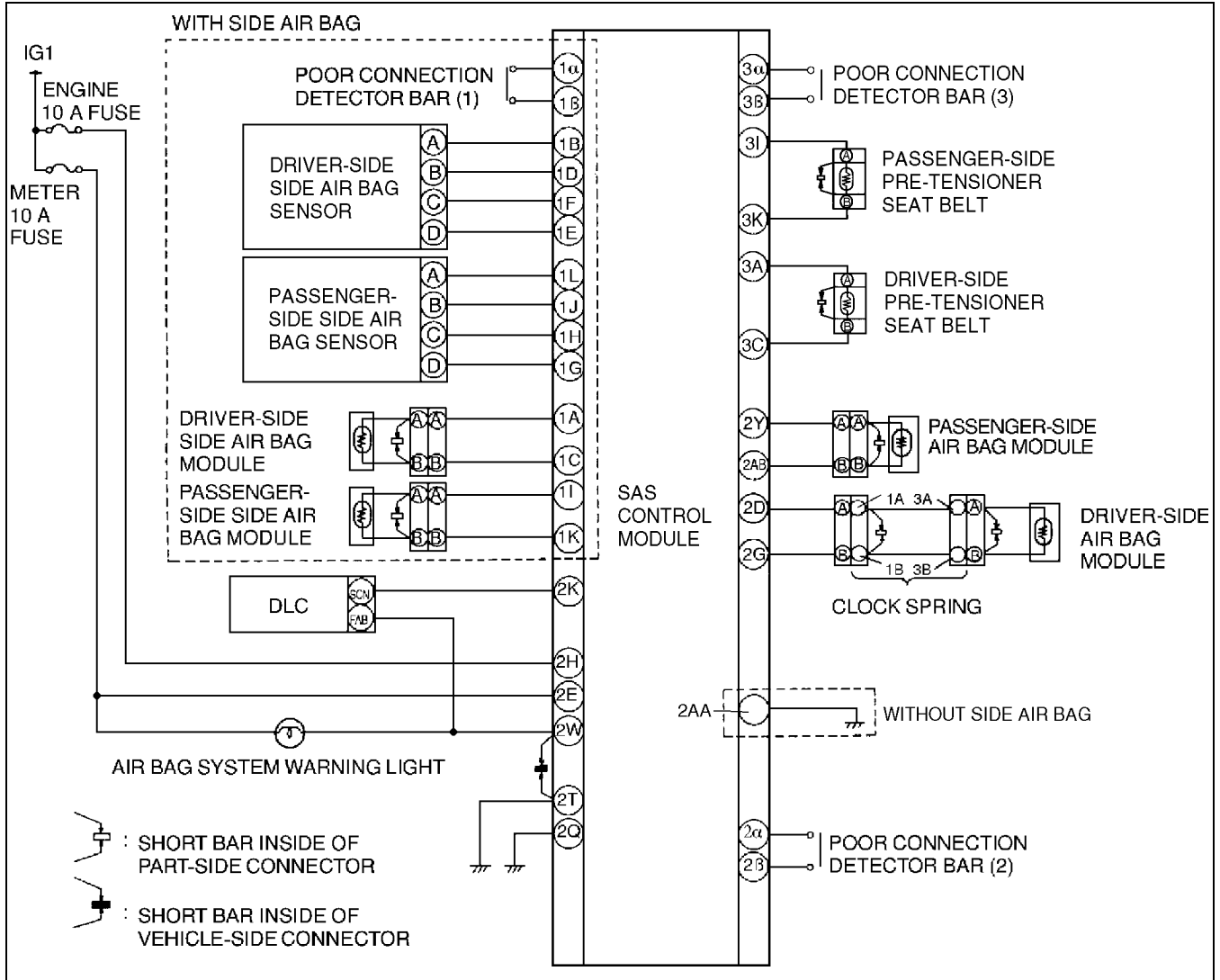

Z3U0802W001

### FOREWORD

- Use the following flowchart to verify the cause of the trouble.

A3U080201046W02

### Flowchart

#### Note

- While performing the inspection of the past malfunction code, the applicable DTCs may be added to memory by removing or disconnecting the related parts. Inspect only the DTCs that were indicated before inspecting.
- When DTCs of present malfunction are no longer output after present and/or past malfunctions have been repaired, be sure to perform past malfunction display cancellation to prevent repair of malfunctions that have already been repaired.

# ON-BOARD DIAGNOSTIC

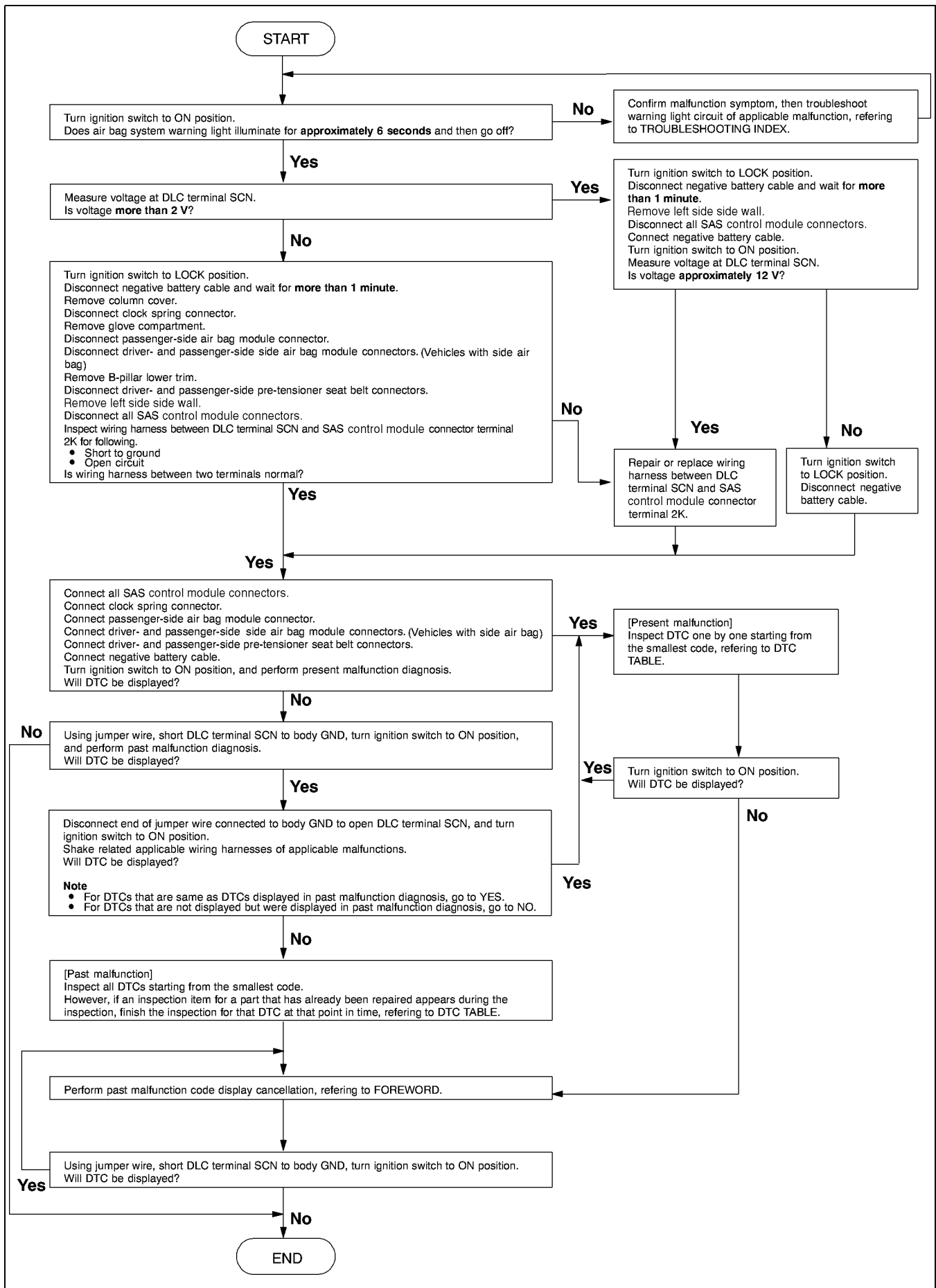

# ON-BOARD DIAGNOSTIC

## Post-repair Operation

### Past malfunction code display cancellation

#### Caution

- Connecting the wrong DLC terminal may possibly cause a malfunction. Carefully connect the specified terminal only.

1. Turn the ignition switch to the ON position.
2. Wait until the air bag system warning light illuminates **approximately 6 seconds** and goes off.
3. Perform both the following steps alternately **three times** each at **0.5—1.5 seconds** intervals.
  - (1) Use a jumper wire to short the DLC terminal SCN to body GND.
  - (2) Disconnect the jumper wire from body GND.
4. If the DTCs are displayed, wait until they disappear.
5. Using a jumper wire, short the DLC terminal SCN to body GND to verify that the DTCs of the past malfunction are not displayed.
  - If the DTCs are still displayed, perform the past malfunction display cancellation again.
6. Turn the ignition switch to the LOCK position.
7. Disconnect the jumper wire from the DLC.

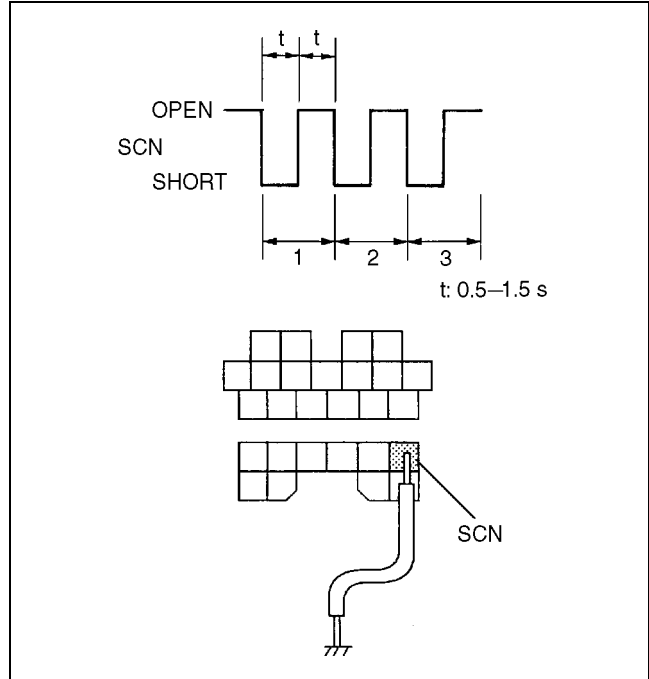

ZLU0802W001

### DTC TABLE

A3U080201046W03











- DTCs are common for present and past malfunction diagnosis.

#### Note

- When DTCs not shown in the DTC table are displayed, replace the SAS control module.
- After a new SAS control module is installed, the air bag system warning light continuously flashes when the ignition switch is turned to ON position. This is the deployment authorization standby code output by the SAS control module. Perform the deployment authorization and restore the system to an operational state.
- If the air bag system warning light does not illuminate or remains illuminated when the ignition switch is turned to ON position, inspect and repair the air bag system warning light circuitry and then confirm that the air bag system warning light is operational.

DTC	Output signal	Malfunction location	Page
01		SAS control module connector poor connection	(See 08-02-6 DTC 01)
02		SAS control module	(See 08-02-7 DTC 02)
03		Power supply of SAS control module	(See 08-02-8 DTC 03)
06		Driver-side air bag module system	(See 08-02-9 DTC 06)

## ON-BOARD DIAGNOSTIC

DTC	Output signal	Malfunction location	Page
07		Passenger-side air bag module system	(See 08-02-12 DTC 07)
11		Driver-side pre-tensioner seat belt system	(See 08-02-13 DTC 11)
12		Passenger-side pre-tensioner seat belt system	(See 08-02-15 DTC 12)
22		Driver-side side air bag sensor system (Internal circuit abnormal)	(See 08-02-17 DTC 22)
25		Driver-side side air bag sensor system (Communication error)	(See 08-02-20 DTC 25)
26		Driver-side side air bag module system	(See 08-02-22 DTC 26)
32		Passenger-side side air bag sensor system (Internal circuit abnormal)	(See 08-02-25 DTC 32)
35		Passenger-side side air bag sensor system (Communication error)	(See 08-02-28 DTC 35)
37		Passenger-side side air bag module system	(See 08-02-30 DTC 37)
91		Air bag system warning light system	(See 08-02-33 DTC 91)
-	Continuously flashes	Deployment authorization standby code	—

08-02

# ON-BOARD DIAGNOSTIC

DTC 01

A3U080201046W04

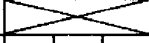
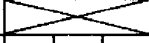
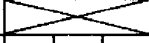
<b>DTC 01</b>	<b>SAS control module connector poor connection</b>																																	
<b>DETECTION CONDITION</b>	<p><b>Warning</b></p> <ul style="list-style-type: none"> <li>• <b>Detection conditions are for understanding DTC outline before performing inspection. Performing inspection with only detection conditions may cause injury due to operating error or damage the system. When performing inspection, always follow diagnostic procedure.</b></li> </ul> <ul style="list-style-type: none"> <li>• There is no continuity between poor connection detector bar terminals of SAS control module.</li> <li>• Terminal 2AA of SAS control module connector is open. (Vehicles without side air bag)</li> </ul>																																	
<b>POSSIBLE CAUSE</b>	<ul style="list-style-type: none"> <li>• Poor connection of any SAS control module connectors.</li> <li>• Malfunction of any SAS control module connectors.</li> <li>• Open or short circuit in wiring harness between SAS control module and ground.</li> <li>• SAS control module malfunction.</li> </ul>																																	
<p>SAS CONTROL MODULE CONNECTOR</p> <table border="1" style="margin: auto; border-collapse: collapse;"> <tr> <td>2AE</td><td>2AB</td><td>2Y</td><td></td><td colspan="4" style="text-align: center;"></td><td>2G</td><td>2D</td><td>2A</td> </tr> <tr> <td>2AF</td><td>2AC</td><td>2Z</td><td>2W</td><td>2T</td><td>2Q</td><td>2N</td><td>2K</td><td>2H</td><td>2E</td><td>2B</td> </tr> <tr> <td>2AG</td><td>2AD</td><td>2AA</td><td>2X</td><td>2U</td><td>2R</td><td>2O</td><td>2L</td><td>2I</td><td>2F</td><td>2C</td> </tr> </table> <p>HARNESS SIDE CONNECTOR (VIEW FROM HARNESS SIDE)</p>		2AE	2AB	2Y						2G	2D	2A	2AF	2AC	2Z	2W	2T	2Q	2N	2K	2H	2E	2B	2AG	2AD	2AA	2X	2U	2R	2O	2L	2I	2F	2C
2AE	2AB	2Y						2G	2D	2A																								
2AF	2AC	2Z	2W	2T	2Q	2N	2K	2H	2E	2B																								
2AG	2AD	2AA	2X	2U	2R	2O	2L	2I	2F	2C																								

**Diagnostic procedure**

STEP	INSPECTION		ACTION
1	<p><b>VERIFY THAT ALL SAS CONTROL MODULE CONNECTORS ARE CONNECTED WITH SAS CONTROL MODULE</b></p> <p><b>Warning</b></p> <ul style="list-style-type: none"> <li>• <b>Handling air bag system components improperly can accidentally deploy air bag modules and pre-tensioner seat belts, which may seriously injure you. Read AIR BAG SYSTEM SERVICE WARNINGS before handling air bag system components. (See 08-10-3 AIR BAG SYSTEM SERVICE WARNINGS)</b></li> </ul> <ul style="list-style-type: none"> <li>• Turn ignition switch to LOCK position.</li> <li>• Disconnect negative battery cable and wait for <b>more than 1 minute</b>.</li> <li>• Remove left side side wall.</li> <li>• Are all SAS control module connectors securely connected?</li> </ul>	<p>Yes</p> <p>No</p>	<p>Go to next step.</p> <p>Reconnect connector properly.</p>
2	<p><b>INSPECT ALL SAS CONTROL MODULE CONNECTORS</b></p> <ul style="list-style-type: none"> <li>• Remove column cover.</li> <li>• Disconnect clock spring connector.</li> <li>• Remove glove compartment.</li> <li>• Disconnect passenger-side air bag module connector.</li> <li>• Disconnect driver- and passenger-side side air bag module connectors. (Vehicles with side air bag)</li> <li>• Remove B-pillar lower trims.</li> <li>• Disconnect driver-and passenger-side pre-tensioner seat belt connectors.</li> <li>• Disconnect all SAS control module connectors.</li> <li>• Are poor connection detector bars of all SAS control module connectors okay?</li> </ul>	<p>Yes</p> <p>No</p>	<p>Go to next step.</p> <p>Replace wiring harnesses.</p>

## ON-BOARD DIAGNOSTIC

STEP	INSPECTION	ACTION	
3	<ul style="list-style-type: none"> <li>• Is vehicle equipped with side air bag?</li> </ul>	Yes	<b>Present malfunction diagnosis:</b> <ul style="list-style-type: none"> <li>• Replace SAS control module. (See 08–10–12 SAS CONTROL MODULE REMOVAL/INSTALLATION)</li> </ul> <b>Past malfunction diagnosis:</b> <ul style="list-style-type: none"> <li>• Complete inspection by DTC.</li> </ul>
		No	Go to next step.
4	<b>VERIFY THAT TERMINAL 2AA OF SAS CONTROL MODULE CONNECTOR IS GROUNDED</b> <ul style="list-style-type: none"> <li>• Inspect wiring harness between terminal 2AA of SAS control module connector and ground for following.                             <ul style="list-style-type: none"> <li>— Short to power supply</li> <li>— Open circuit</li> </ul> </li> <li>• Is wiring harness okay?</li> </ul>	Yes	<b>Present malfunction diagnosis:</b> <ul style="list-style-type: none"> <li>• Replace SAS control module. (See 08–10–12 SAS CONTROL MODULE REMOVAL/INSTALLATION)</li> </ul> <b>Past malfunction diagnosis:</b> <ul style="list-style-type: none"> <li>• Complete inspection by DTC.</li> </ul>
		No	Replace wiring harness.

### DTC 02

A3U080201046W05

DTC 02	SAS control module
<b>DETECTION CONDITION</b>	<b>Warning</b> <ul style="list-style-type: none"> <li>• <b>Detection conditions are for understanding DTC outline before performing inspection. Performing inspection with only detection conditions may cause injury due to operating error or damage the system. When performing inspection, always follow diagnostic procedure.</b></li> <li>• Malfunction in SAS control module inner circuit.</li> </ul>
<b>POSSIBLE CAUSE</b>	<ul style="list-style-type: none"> <li>• SAS control module malfunction.</li> </ul>

08-02

### Diagnostic procedure

ACTION
<ul style="list-style-type: none"> <li>• Replace SAS control module. (See 08–10–12 SAS CONTROL MODULE REMOVAL/INSTALLATION)</li> </ul>

# ON-BOARD DIAGNOSTIC

DTC 03

A3U080201046W06

<b>DTC 03</b>	<b>Power supply of SAS control module</b>
<b>DETECTION CONDITION</b>	<p><b>Warning</b></p> <ul style="list-style-type: none"> <li>• <b>Detection conditions are for understanding DTC outline before performing inspection. Performing inspection with only detection conditions may cause injury due to operating error or damage the system. When performing inspection, always follow diagnostic procedure</b></li> </ul> <ul style="list-style-type: none"> <li>• Voltage detected at SAS control module terminals 2E and 2H is <b>9 V or less</b>.</li> </ul>
<b>POSSIBLE CAUSE</b>	<p><b>Note</b></p> <ul style="list-style-type: none"> <li>• DTC 03 is indicated when voltages in both of following wiring harnesses drop simultaneously.                             <ul style="list-style-type: none"> <li>— Wiring harness between fuse block connector (JB-01) terminal B and SAS control module connector terminal 2E.</li> <li>— Wiring harness between fuse block connector (JB-02) terminal D and SAS control module connector terminal 2H.</li> </ul> </li> <li>• Weak battery.</li> <li>• Malfunction in wiring harness between battery and SAS control module.</li> <li>• SAS control module malfunction.</li> </ul>

FUSE BLOCK CONNECTOR (JB-01)

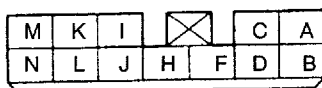

HARNESS SIDE CONNECTOR  
(VIEW FROM HARNESS SIDE)

FUSE BLOCK CONNECTOR (JB-02)

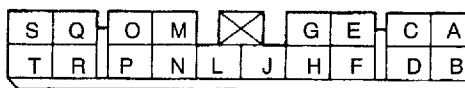

HARNESS SIDE CONNECTOR  
(VIEW FROM HARNESS SIDE)

SAS CONTROL MODULE CONNECTOR

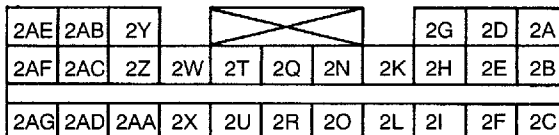

HARNESS SIDE CONNECTOR  
(VIEW FROM HARNESS SIDE)

**Diagnostic procedure**

STEP	INSPECTION		ACTION
1	<p><b>INSPECT BATTERY</b></p> <ul style="list-style-type: none"> <li>• Measure voltage of battery.</li> <li>• Is voltage <b>more than 9 V</b>?</li> </ul>	Yes	Go to next step.
		No	Battery is weak. Inspect charge/discharge system. (See 01-17-1 BATTERY INSPECTION)
2	<p><b>INSPECT WIRING HARNESS BETWEEN BATTERY AND FUSE BLOCK</b></p> <ul style="list-style-type: none"> <li>• Remove driver-side front scuff plate.</li> <li>• Remove driver-side front side trim.</li> <li>• Remove fuse block without disconnecting connectors.</li> <li>• Turn ignition switch to ON position.</li> <li>• Measure voltage at terminals B (JB-01) and D (JB-02) of fuse block connectors.</li> <li>• Is voltage of at least either terminal <b>more than 9 V</b>?</li> </ul>	Yes	Go to next step.
		No	Repair wiring harnesses. (Battery—fuse block)



# ON-BOARD DIAGNOSTIC

STEP	INSPECTION		ACTION
3	<p><b>INSPECT WIRING HARNESS BETWEEN FUSE BLOCK AND SAS CONTROL MODULE</b></p> <p><b>Warning</b></p> <ul style="list-style-type: none"> <li>• <b>Handling air bag system components improperly can accidentally deploy air bag modules and pre-tensioner seat belts, which may seriously injure you. Read AIR BAG SYSTEM SERVICE WARNINGS before handling air bag system components. (See 08-10-3 AIR BAG SYSTEM SERVICE WARNINGS)</b></li> </ul> <ul style="list-style-type: none"> <li>• Turn ignition switch to LOCK position.</li> <li>• Disconnect negative battery cable and wait for <b>more than 1 minute</b>.</li> <li>• Remove column cover.</li> <li>• Disconnect clock spring connector.</li> <li>• Remove glove compartment.</li> <li>• Disconnect passenger-side air bag module connector.</li> <li>• Disconnect driver- and passenger-side side air bag module connectors. (Vehicles with side air bag)</li> <li>• Remove B-pillar lower trims.</li> <li>• Disconnect driver-and passenger-side pre-tensioner seat belt connectors.</li> <li>• Remove left side side wall.</li> <li>• Disconnect all SAS control module connectors.</li> <li>• Connect negative battery cable.</li> <li>• Turn ignition switch to ON position.</li> <li>• Measure voltage at terminals 2E and 2H of SAS control module connector.</li> <li>• Is voltage of at least either terminal <b>more than 9 V</b>?</li> </ul>	<p>Yes</p> <p>No</p>	<p><b>Present malfunction diagnosis:</b></p> <ul style="list-style-type: none"> <li>• Replace SAS control module. (See 08-10-12 SAS CONTROL MODULE REMOVAL/INSTALLATION)</li> </ul> <p><b>Past malfunction diagnosis:</b></p> <ul style="list-style-type: none"> <li>• Complete inspection by DTC.</li> </ul> <p>Replace wiring harness. (Fuse block-SAS control module)</p>

08-02

## DTC 06

A3U080201046W07

DTC 06	Driver-side air bag module system
<b>DETECTION CONDITION</b>	<p><b>Warning</b></p> <ul style="list-style-type: none"> <li>• <b>Detection conditions are for understanding DTC outline before performing inspection. Performing inspection with only detection conditions may cause injury due to operating error or damage the system. When performing inspection, always follow diagnostic procedure.</b></li> </ul> <ul style="list-style-type: none"> <li>• Resistance detected between terminals 2D and 2G of SAS control module is other than <b>1.85—3.46 ohm</b>.</li> <li>• Short circuit in wiring harness related SAS control module terminal 2D or 2G.</li> </ul>
<b>POSSIBLE CAUSE</b>	<ul style="list-style-type: none"> <li>• Driver-side air bag module malfunction.</li> <li>• Clock spring malfunction.</li> <li>• Malfunction of connectors between clock spring and SAS control module.</li> <li>• Open or short circuit in wiring harness between clock spring and SAS control module.</li> <li>• SAS control module malfunction.</li> </ul>

CLOCK SPRING

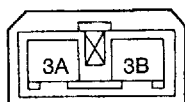

COMPONENT SIDE CONNECTOR (VIEW FROM TERMINAL SIDE)

CLOCK SPRING CONNECTOR

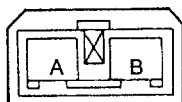

HARNESS SIDE CONNECTOR (VIEW FROM TERMINAL SIDE)

SAS CONTROL MODULE CONNECTOR

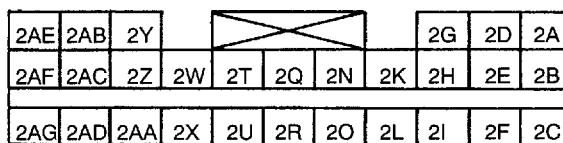

HARNESS SIDE CONNECTOR (VIEW FROM HARNESS SIDE)

## ON-BOARD DIAGNOSTIC

### Diagnostic procedure

STEP	INSPECTION	ACTION	
1	<b>INSPECT SEPARATOR* OF CLOCK SPRING</b>  <b>Warning</b> <ul style="list-style-type: none"> <li>• <b>Handling air bag system components improperly can accidentally deploy air bag modules and pre-tensioner seat belts, which may seriously injure you. Read AIR BAG SYSTEM SERVICE WARNINGS before handling air bag system components. (See 08-10-3 AIR BAG SYSTEM SERVICE WARNINGS)</b></li> </ul> <ul style="list-style-type: none"> <li>• Turn ignition switch to LOCK position.</li> <li>• Disconnect negative battery cable and wait for <b>more than 1 minute</b>.</li> <li>• Remove driver-side air bag module. (See 08-10-5 DRIVER-SIDE AIR BAG MODULE REMOVAL/INSTALLATION)</li> <li>• Is separator* of clock spring okay?</li> </ul>	Yes	<b>Present malfunction diagnosis:</b> <ul style="list-style-type: none"> <li>• Go to next step.</li> </ul> <b>Past malfunction diagnosis:</b> <ul style="list-style-type: none"> <li>• Go to Step 6.</li> </ul>
		No	Replace clock spring. (See 08-10-9 CLOCK SPRING REMOVAL/INSTALLATION)
2	<b>VERIFY WHETHER MALFUNCTION IS IN DRIVER-SIDE AIR BAG MODULE OR OTHER PARTS</b> <ul style="list-style-type: none"> <li>• Connect leads of <b>SST</b> (Fuel And Thermometer checker) or apply <b>2 ohms</b> resistor to clock spring terminals 3A and 3B.</li> <li>• Set resistance of <b>SST</b> (Fuel And Thermometer checker) to <b>2 ohms</b>.</li> <li>• Connect negative battery cable.</li> <li>• Turn ignition switch to ON position.</li> <li>• Is DTC 06 indicated?</li> </ul>	Yes	Go to next step.
		No	Replace driver-side air bag module. (See 08-10-5 DRIVER-SIDE AIR BAG MODULE REMOVAL/INSTALLATION)
3	<b>INSPECT SEPARATOR* OF CLOCK SPRING CONNECTOR</b> <ul style="list-style-type: none"> <li>• Turn ignition switch to LOCK position.</li> <li>• Disconnect negative battery cable and wait for <b>more than 1 minute</b>.</li> <li>• Remove column cover.</li> <li>• Disconnect clock spring connector.</li> <li>• Is separator* of clock spring connector okay?</li> </ul>	Yes	Go to next step.
		No	Replace wiring harness.
4	<b>VERIFY WHETHER MALFUNCTION IS IN CLOCK SPRING OR OTHER PARTS</b> <ul style="list-style-type: none"> <li>• Connect leads of <b>SST</b> (Fuel And Thermometer checker) or apply <b>2 ohms</b> resistor clock spring connector terminals A and B.</li> <li>• Set resistance of <b>SST</b> (Fuel And Thermometer checker) to <b>2 ohms</b>.</li> <li>• Connect negative battery cable.</li> <li>• Turn ignition switch to ON position.</li> <li>• Is DTC 06 indicated?</li> </ul>	Yes	Go to next step.
		No	Replace clock spring. (See 08-10-9 CLOCK SPRING REMOVAL/INSTALLATION)

## ON-BOARD DIAGNOSTIC

STEP	INSPECTION	ACTION	
5	<b>INSPECT WIRING HARNESS BETWEEN CLOCK SPRING AND SAS CONTROL MODULE</b> <ul style="list-style-type: none"> <li>• Turn ignition switch to LOCK position.</li> <li>• Disconnect negative battery cable and wait for <b>more than 1 minute</b>.</li> <li>• Remove glove compartment.</li> <li>• Disconnect passenger-side air bag module connector.</li> <li>• Disconnect driver- and passenger-side side air bag module connectors. (Vehicles with side air bag)</li> <li>• Remove B-pillar lower trims.</li> <li>• Disconnect driver-and passenger-side pre-tensioner seat belt connectors.</li> <li>• Remove left side side wall.</li> <li>• Disconnect all SAS control module connectors.</li> <li>• Are wiring harnesses okay?</li> </ul>	Yes	Replace SAS control module. (See 08-10-12 SAS CONTROL MODULE REMOVAL/INSTALLATION)
		No	Replace wiring harnesses.
6	<b>INSPECT SEPARATOR* OF CLOCK SPRING CONNECTOR</b> <ul style="list-style-type: none"> <li>• Remove column cover.</li> <li>• Disconnect clock spring connector.</li> <li>• Is separator* of clock spring connector okay?</li> </ul>	Yes	Go to next step.
		No	Replace wiring harness.
7	<b>INSPECT CLOCK SPRING</b> <ul style="list-style-type: none"> <li>• Remove clock spring. (See 08-10-9 CLOCK SPRING REMOVAL/INSTALLATION)</li> <li>• Inspect clock spring. (See 08-10-10 CLOCK SPRING INSPECTION)</li> <li>• Is clock spring okay?</li> </ul>	Yes	Go to next step.
		No	Replace wiring harness.
8	<b>INSPECT WIRING HARNESS BETWEEN CLOCK SPRING AND SAS CONTROL MODULE</b> <ul style="list-style-type: none"> <li>• Remove glove compartment.</li> <li>• Disconnect passenger-side air bag module connector.</li> <li>• Disconnect driver- and passenger-side side air bag module connectors. (Vehicles with side air bag)</li> <li>• Remove B-pillar lower trims.</li> <li>• Disconnect driver-and passenger-side pre-tensioner seat belt connectors.</li> <li>• Remove left side side wall.</li> <li>• Disconnect all SAS control module connectors.</li> <li>• Inspect wiring harness between terminal 2D of SAS control module connector and terminal A of clock spring connector, and between terminal 2G of SAS control module connector and terminal B of clock spring connector for following.                             <ul style="list-style-type: none"> <li>— Short to ground</li> <li>— Short to power supply</li> <li>— Open circuit</li> </ul> </li> <li>• Are wiring harnesses okay?</li> </ul>	Yes	Replace driver-side air bag module. (See 08-10-5 DRIVER-SIDE AIR BAG MODULE REMOVAL/INSTALLATION)
		No	Replace wiring harness.

08-02

\* : Consists of 2 parts of female connector that separate the short bar from the terminal when connected to the male connector.

# ON-BOARD DIAGNOSTIC

DTC 07

A3U080201046W08

<b>DTC 07</b>	<b>Passenger-side air bag module system</b>
<b>DETECTION CONDITION</b>	<p><b>Warning</b></p> <ul style="list-style-type: none"> <li>Detection conditions are for understanding DTC outline before performing inspection. Performing inspection with only detection conditions may cause injury due to operating error or damage the system. When performing inspection, always follow diagnostic procedure.</li> </ul> <ul style="list-style-type: none"> <li>Resistance detected between terminals 2Y and 2AB of SAS control module is other than <b>1.63—2.71 ohm</b>.</li> <li>Short circuit in wiring harness related SAS control module terminal 2Y or 2AB.</li> </ul>
<b>POSSIBLE CAUSE</b>	<ul style="list-style-type: none"> <li>Passenger-side air bag module malfunction.</li> <li>Malfunction of connectors between passenger-side air bag module and SAS control module.</li> <li>Open or short circuit in wiring harness between passenger-side air bag module and SAS control module.</li> <li>SAS control module malfunction.</li> </ul>

PASSENGER-SIDE AIR BAG MODULE CONNECTOR

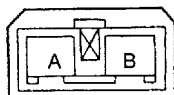

HARNESS SIDE CONNECTOR (VIEW FROM TERMINAL SIDE)

SAS CONTROL MODULE CONNECTOR

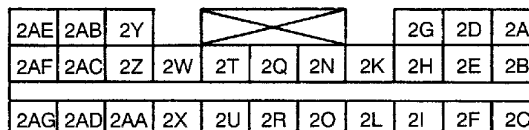

HARNESS SIDE CONNECTOR (VIEW FROM HARNESS SIDE)

**Diagnostic procedure**

STEP	INSPECTION		ACTION
1	<p><b>INSPECT SEPARATOR* OF PASSENGER-SIDE AIR BAG MODULE CONNECTOR</b></p> <p><b>Warning</b></p> <ul style="list-style-type: none"> <li>Handling air bag system components improperly can accidentally deploy air bag modules and pre-tensioner seat belts, which may seriously injure you. Read AIR BAG SYSTEM SERVICE WARNINGS before handling air bag system components. (See 08-10-3 AIR BAG SYSTEM SERVICE WARNINGS)</li> </ul> <ul style="list-style-type: none"> <li>Turn ignition switch to LOCK position.</li> <li>Disconnect negative battery cable and wait for <b>more than 1 minute</b>.</li> <li>Remove glove compartment.</li> <li>Disconnect passenger-side air bag module connector.</li> <li>Is separator* of passenger-side air bag module connector okay?</li> </ul>	Yes	<p><b>Present malfunction diagnosis:</b></p> <ul style="list-style-type: none"> <li>Go to next step.</li> </ul> <p><b>Past malfunction diagnosis:</b></p> <ul style="list-style-type: none"> <li>Go to Step 3.</li> </ul>
		No	Replace wiring harness.
2	<p><b>VERIFY WHETHER MALFUNCTION IS IN PASSENGER-SIDE AIR BAG MODULE OR OTHER PARTS</b></p> <ul style="list-style-type: none"> <li>Connect leads of <b>SST</b> (Fuel And Thermometer checker) or apply <b>2 ohms</b> resistor to passenger-side air bag module connector terminals A and B.</li> <li>Set resistance of <b>SST</b> (Fuel And Thermometer checker) to <b>2 ohms</b>.</li> <li>Connect negative battery cable.</li> <li>Turn ignition switch to ON position.</li> <li>Is DTC 07 indicated?</li> </ul>	Yes	Go to next step.
		No	Replace passenger-side air bag module. (See 08-10-6 PASSENGER-SIDE AIR BAG MODULE REMOVAL/INSTALLATION)

# ON-BOARD DIAGNOSTIC

STEP	INSPECTION		ACTION
3	<b>INSPECT WIRING HARNESS BETWEEN PASSENGER-SIDE AIR BAG MODULE AND SAS CONTROL MODULE</b> <ul style="list-style-type: none"> <li>Turn ignition switch to LOCK position.</li> <li>Disconnect negative battery cable and wait for <b>more than 1 minute</b>.</li> <li>Remove column cover.</li> <li>Disconnect clock spring connector.</li> <li>Disconnect driver- and passenger-side side air bag module connectors. (Vehicles with side air bag)</li> <li>Remove B-pillar lower trims.</li> <li>Disconnect driver-and passenger-side pre-tensioner seat belt connectors.</li> <li>Remove left side side wall.</li> <li>Disconnect all SAS control module connectors.</li> <li>Inspect wiring harness between terminal 2Y of SAS control module connector and terminal A of passenger-side air bag module connector, and between terminal 2AB of SAS control module connector and terminal B of passenger-side air bag module connector for following.                             <ul style="list-style-type: none"> <li>— Short to ground</li> <li>— Short to power supply</li> <li>— Open circuit</li> </ul> </li> <li>Are wiring harnesses okay?</li> </ul>	Yes	<b>Present malfunction diagnosis:</b> <ul style="list-style-type: none"> <li>Replace SAS control module. (See 08–10–12 SAS CONTROL MODULE REMOVAL/INSTALLATION)</li> </ul> <b>Past malfunction diagnosis:</b> <ul style="list-style-type: none"> <li>Replace passenger-side air bag module. (See 08–10–6 PASSENGER-SIDE AIR BAG MODULE REMOVAL/INSTALLATION)</li> </ul>
		No	Replace wiring harness.

08-02

\* : Consists of the 2 parts of the female connector that separate the short bar from the terminal when connected to the male connector.

## DTC 11

A3U080201046W09

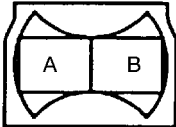
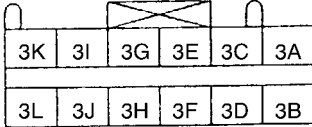
DTC 11	Driver-side pre-tensioner seat belt system
<b>DETECTION CONDITION</b>	<p><b>Warning</b></p> <ul style="list-style-type: none"> <li>Detection conditions are for understanding DTC outline before performing inspection. Performing inspection with only detection conditions may cause injury due to operating error or damage the system. When performing inspection, always follow diagnostic procedure.</li> </ul> <ul style="list-style-type: none"> <li>Abnormal resistance (other than <b>1.83—2.81 ohm</b>) detected in driver-side pre-tensioner seat belt circuit.</li> <li>Short circuit in wiring harness related terminal 3A or 3C of SAS control module.</li> </ul>
<b>POSSIBLE CAUSE</b>	<ul style="list-style-type: none"> <li>Driver-side pre-tensioner seat belt malfunction.</li> <li>Malfunction of connectors between driver-side pre-tensioner seat belt and SAS control module.</li> <li>Open or short circuit in wiring harness between driver-side pre-tensioner seat belt and SAS control module.</li> <li>SAS control module malfunction.</li> </ul>
<p>DRIVER-SIDE PRE-TENSIONER SEAT BELT CONNECTOR</p>  <p>HARNESS SIDE CONNECTOR (VIEW FROM TERMINAL SIDE)</p>	<p>SAS CONTROL MODULE CONNECTOR</p>  <p>HARNESS SIDE CONNECTOR (VIEW FROM HARNESS SIDE)</p>

## ON-BOARD DIAGNOSTIC

### Diagnostic procedure

STEP	INSPECTION	ACTION	
1	<b>INSPECT DRIVER-SIDE PRE-TENSIONER SEAT BELT CONNECTOR</b>  <b>Warning</b> <ul style="list-style-type: none"> <li>• <b>Handling air bag system components improperly can accidentally deploy air bag modules and pre-tensioner seat belts, which may seriously injure you. Read AIR BAG SYSTEM SERVICE WARNINGS before handling air bag system components. (See 08-10-3 AIR BAG SYSTEM SERVICE WARNINGS)</b></li> </ul> <ul style="list-style-type: none"> <li>• Turn ignition switch to LOCK position.</li> <li>• Disconnect negative battery cable and wait for <b>more than 1 minute</b>.</li> <li>• Remove driver-side B-pillar lower trim.</li> <li>• Disconnect driver-side pre-tensioner seat belt connector.</li> <li>• Is there cracking or chipping in driver-side pre-tensioner seat belt connector?</li> </ul>	Yes	Replace wiring harness.
		No	<b>Present malfunction diagnosis:</b> <ul style="list-style-type: none"> <li>• Go to next step.</li> </ul> <b>Past malfunction diagnosis:</b> <ul style="list-style-type: none"> <li>• Go to Step 3.</li> </ul>
2	<b>VERIFY WHETHER MALFUNCTION IS IN DRIVER-SIDE PRE-TENSIONER SEAT BELT OR OTHER PARTS</b> <ul style="list-style-type: none"> <li>• Connect leads of <b>SST</b> (Fuel and thermometer checker) or apply <b>2 ohms</b> resistor to driver-side pre-tensioner seat belt connector terminals A and B.</li> <li>• Set resistance of <b>SST</b> (Fuel and thermometer checker) to <b>2 ohms</b>.</li> <li>• Connect negative battery cable.</li> <li>• Turn ignition switch to ON position.</li> <li>• Is DTC 11 indicated?</li> </ul>	Yes	Go to next step.
		No	Replace driver-side pre-tensioner seat belt.
3	<b>INSPECT WIRING HARNESS BETWEEN DRIVER-SIDE PRE-TENSIONER SEAT BELT AND SAS CONTROL MODULE</b> <ul style="list-style-type: none"> <li>• Turn ignition switch to LOCK position.</li> <li>• Disconnect negative battery cable and wait for <b>more than 1 minute</b>.</li> <li>• Remove column cover.</li> <li>• Disconnect clock spring connector.</li> <li>• Remove glove compartment.</li> <li>• Disconnect passenger-side air bag module connector.</li> <li>• Disconnect driver- and passenger-side side air bag module connectors. (Vehicles with side air bag)</li> <li>• Remove passenger-side B-pillar lower trim.</li> <li>• Disconnect passenger-side pre-tensioner seat belt connector.</li> <li>• Remove left side side wall.</li> <li>• Disconnect all SAS control module connectors.</li> <li>• Inspect wiring harness between SAS control module connector terminal 3A and driver-side pre-tensioner seat belt connector terminal A, and between SAS control module connector terminal 3C and driver-side pre-tensioner seat belt connector terminal B for following.                             <ul style="list-style-type: none"> <li>— Short to ground</li> <li>— Short to power supply</li> <li>— Open circuit</li> </ul> </li> <li>• Are wiring harnesses okay?</li> </ul>	Yes	<b>Present malfunction diagnosis:</b> <ul style="list-style-type: none"> <li>• Replace SAS control module. (See 08-10-12 SAS CONTROL MODULE REMOVAL/INSTALLATION)</li> </ul> <b>Past malfunction diagnosis:</b> <ul style="list-style-type: none"> <li>• Replace driver-side pre-tensioner seat belt.</li> </ul>
		No	Replace wiring harness.

# ON-BOARD DIAGNOSTIC

DTC 12

A3U080201046W10

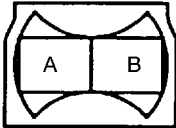
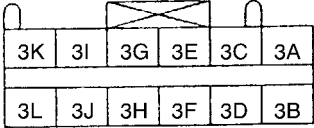
<b>DTC 12</b>	<b>Passenger-side pre-tensioner seat belt system</b>
<b>DETECTION CONDITION</b>	<p><b>Warning</b></p> <ul style="list-style-type: none"> <li>• <b>Detection conditions are for understanding DTC outline before performing inspection. Performing inspection with only detection conditions may cause injury due to operating error or damage the system. When performing inspection, always follow diagnostic procedure.</b></li> <li>• Abnormal resistance (other than <b>1.83—2.81 ohm</b>) detected in passenger-side pre-tensioner seat belt circuit.</li> <li>• Short circuit in wiring harness related terminal 3I or 3K of SAS control module.</li> </ul>
<b>POSSIBLE CAUSE</b>	<ul style="list-style-type: none"> <li>• Passenger-side pre-tensioner seat belt malfunction.</li> <li>• Malfunction of connectors between passenger-side pre-tensioner seat belt and SAS control module.</li> <li>• Open or short circuit in wiring harness between passenger-side pre-tensioner seat belt and SAS control module.</li> <li>• SAS control module malfunction.</li> </ul>
<p>PASSENGER-SIDE PRE-TENSIONER SEAT BELT CONNECTOR</p>  <p>HARNESS SIDE CONNECTOR (VIEW FROM TERMINAL SIDE)</p>	<p>SAS CONTROL MODULE CONNECTOR</p>  <p>HARNESS SIDE CONNECTOR (VIEW FROM HARNESS SIDE)</p>

08-02

**Diagnostic procedure**

STEP	INSPECTION		ACTION
1	<p><b>INSPECT PASSENGER-SIDE PRE-TENSIONER SEAT BELT CONNECTOR</b></p> <p><b>Warning</b></p> <ul style="list-style-type: none"> <li>• <b>Handling air bag system components improperly can accidentally deploy air bag modules and pre-tensioner seat belts, which may seriously injure you. Read AIR BAG SYSTEM SERVICE WARNINGS before handling air bag system components. (See 08-10-3 AIR BAG SYSTEM SERVICE WARNINGS)</b></li> <li>• Turn ignition switch to LOCK position.</li> <li>• Disconnect negative battery cable and wait for <b>more than 1 minute</b>.</li> <li>• Remove passenger-side B-pillar lower trim.</li> <li>• Disconnect passenger-side pre-tensioner seat belt connector.</li> <li>• Is there cracking or chipping in passenger-side pre-tensioner seat belt connector?</li> </ul>	<p>Yes</p> <p>No</p>	<p>Replace wiring harness.</p> <p><b>Present malfunction diagnosis:</b></p> <ul style="list-style-type: none"> <li>• Go to next step.</li> </ul> <p><b>Past malfunction diagnosis:</b></p> <ul style="list-style-type: none"> <li>• Go to Step 3.</li> </ul>
2	<p><b>VERIFY WHETHER MALFUNCTION IS IN PASSENGER-SIDE PRE-TENSIONER SEAT BELT OR OTHER PARTS</b></p> <ul style="list-style-type: none"> <li>• Connect leads of <b>SST</b> (Fuel and thermometer checker) or apply <b>2 ohms</b> resistor to passenger-side pre-tensioner seat belt connector terminals A and B.</li> <li>• Set resistance of <b>SST</b> (Fuel and thermometer checker) to <b>2 ohms</b>.</li> <li>• Connect negative battery cable.</li> <li>• Turn ignition switch to ON position.</li> <li>• Is DTC 12 indicated?</li> </ul>	<p>Yes</p> <p>No</p>	<p>Go to next step.</p> <p>Replace passenger-side pre-tensioner seat belt.</p>

## ON-BOARD DIAGNOSTIC

STEP	INSPECTION	ACTION				
3	<p><b>INSPECT WIRING HARNESS BETWEEN PASSENGER-SIDE PRE-TENSIONER SEAT BELT AND SAS CONTROL MODULE</b></p> <ul style="list-style-type: none"> <li>• Turn ignition switch to LOCK position.</li> <li>• Disconnect negative battery cable and wait for <b>more than 1 minute</b>.</li> <li>• Remove column cover.</li> <li>• Disconnect clock spring connector.</li> <li>• Remove glove compartment.</li> <li>• Disconnect passenger-side air bag module connector</li> <li>• Disconnect driver- and passenger-side side air bag module connectors. (Vehicles with side air bag)</li> <li>• Remove driver-side B-pillar lower trim.</li> <li>• Disconnect driver-side pre-tensioner seat belt connector.</li> <li>• Remove left side side wall.</li> <li>• Disconnect all SAS control module connectors.</li> <li>• Inspect wiring harness between SAS control module connector terminal 3I and passenger-side pre-tensioner seat belt connector terminal A, and between SAS control module connector terminal 3K and passenger-side pre-tensioner seat belt connector terminal B for following. <ul style="list-style-type: none"> <li>— Short to ground</li> <li>— Short to power supply</li> <li>— Open circuit</li> </ul> </li> <li>• Are wiring harnesses okay?</li> </ul>	<table border="0" style="width: 100%;"> <tr> <td style="width: 50px; vertical-align: top;">Yes</td> <td> <p><b>Present malfunction diagnosis:</b></p> <ul style="list-style-type: none"> <li>• Replace SAS control module. (See 08–10–12 SAS CONTROL MODULE REMOVAL/INSTALLATION)</li> </ul> <p><b>Past malfunction diagnosis:</b></p> <ul style="list-style-type: none"> <li>• Replace passenger-side pre-tensioner seat belt.</li> </ul> </td> </tr> <tr> <td style="vertical-align: top;">No</td> <td> <p>Replace wiring harness.</p> </td> </tr> </table>	Yes	<p><b>Present malfunction diagnosis:</b></p> <ul style="list-style-type: none"> <li>• Replace SAS control module. (See 08–10–12 SAS CONTROL MODULE REMOVAL/INSTALLATION)</li> </ul> <p><b>Past malfunction diagnosis:</b></p> <ul style="list-style-type: none"> <li>• Replace passenger-side pre-tensioner seat belt.</li> </ul>	No	<p>Replace wiring harness.</p>
Yes	<p><b>Present malfunction diagnosis:</b></p> <ul style="list-style-type: none"> <li>• Replace SAS control module. (See 08–10–12 SAS CONTROL MODULE REMOVAL/INSTALLATION)</li> </ul> <p><b>Past malfunction diagnosis:</b></p> <ul style="list-style-type: none"> <li>• Replace passenger-side pre-tensioner seat belt.</li> </ul>					
No	<p>Replace wiring harness.</p>					



# ON-BOARD DIAGNOSTIC

DTC 22

A3U080201046W11

<b>DTC 22</b>	<b>Driver-side side air bag sensor system (Internal circuit abnormal)</b>
<b>DETECTION CONDITION</b>	<p><b>Warning</b></p> <ul style="list-style-type: none"> <li>• <b>Detection conditions are for understanding DTC outline before performing inspection. Performing inspection with only detection conditions may cause injury due to operating error or damage the system. When performing inspection, always follow diagnostic procedure.</b></li> </ul> <p><b>Note</b></p> <ul style="list-style-type: none"> <li>• For vehicles without side air bag, DTC 22, 25, 26, 32, 35, or 37 may be indicated concurrently. In such a case, perform only the smallest DTC troubleshooting among them.</li> </ul> <p><b>Vehicles with side air bag</b></p> <ul style="list-style-type: none"> <li>• Malfunction in wiring harness between driver-side side air bag sensor and SAS control module.</li> <li>• Malfunction in driver-side side air bag sensor circuit.</li> </ul> <p><b>Vehicles without side air bag</b></p> <ul style="list-style-type: none"> <li>• Terminal 2AA of SAS control module connector is open.</li> </ul>

<b>POSSIBLE CAUSE</b>	<p><b>Vehicles with side air bag</b></p> <ul style="list-style-type: none"> <li>• Driver-side side air bag sensor malfunction.</li> <li>• Open or short circuit in wiring harness between driver-side side air bag sensor and SAS control module.</li> <li>• SAS control module malfunction.</li> </ul> <p><b>Vehicles without side air bag</b></p> <ul style="list-style-type: none"> <li>• Malfunction of connector between SAS control module and ground.</li> <li>• Open or short circuit in wiring harness between SAS control module and ground.</li> <li>• SAS control module malfunction.</li> </ul>
-----------------------	--

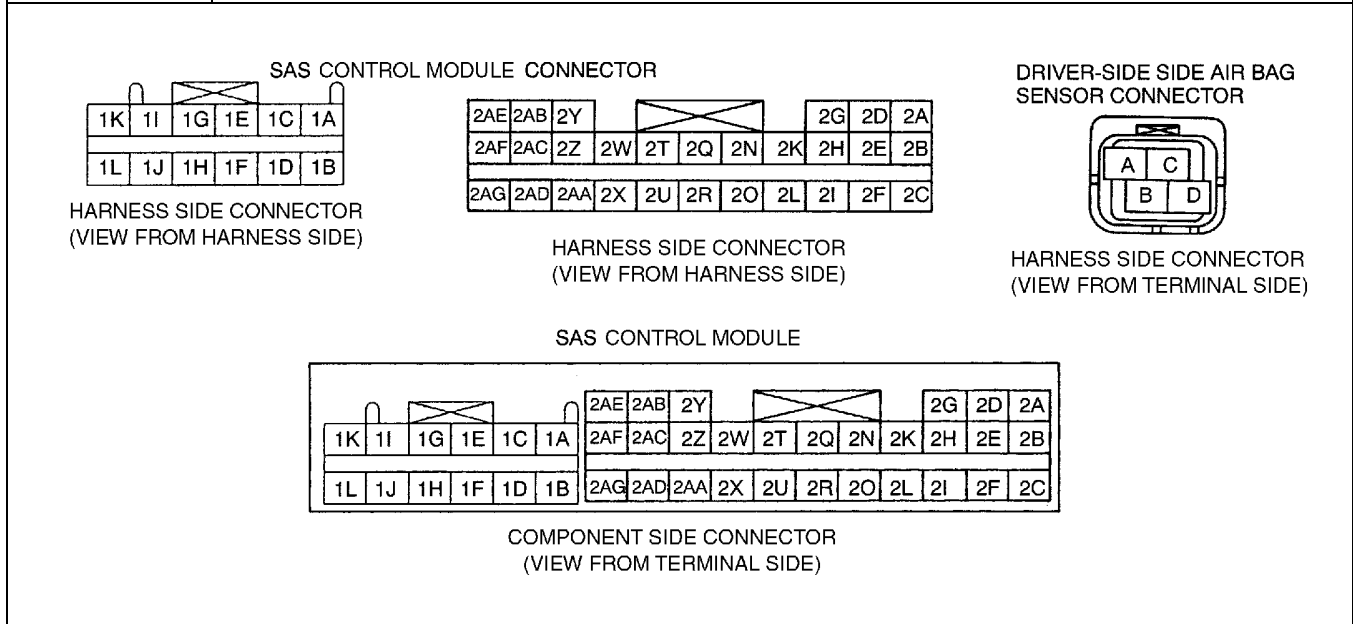

08-02

**Diagnostic procedure**

STEP	INSPECTION		ACTION
1	<ul style="list-style-type: none"> <li>• Is vehicle equipped with side air bag?</li> </ul>	Yes	Go to next step.
		No	Go to Step 6.

## ON-BOARD DIAGNOSTIC

STEP	INSPECTION	ACTION
2	<p><b>INSPECT WIRING HARNESS BETWEEN DRIVER-SIDE SIDE AIR BAG SENSOR AND SAS CONTROL MODULE</b></p> <p><b>Warning</b></p> <ul style="list-style-type: none"> <li>• <b>Handling air bag system components improperly can accidentally deploy air bag modules and pre-tensioner seat belts, which may seriously injure you. Read AIR BAG SYSTEM SERVICE WARNINGS before handling air bag system components. (See 08-10-3 AIR BAG SYSTEM SERVICE WARNINGS)</b></li> </ul> <ul style="list-style-type: none"> <li>• Turn ignition switch to LOCK position.</li> <li>• Disconnect negative battery cable and wait for <b>more than 1 minute</b>.</li> <li>• Remove column cover.</li> <li>• Disconnect clock spring connector.</li> <li>• Remove glove compartment.</li> <li>• Disconnect passenger-side air bag module connector.</li> <li>• Disconnect driver- and passenger-side side air bag module connectors.</li> <li>• Remove B-pillar lower trims.</li> <li>• Disconnect driver-and passenger-side pre-tensioner seat belt connectors.</li> <li>• Remove left side side wall.</li> <li>• Disconnect all SAS control module connectors.</li> <li>• Disconnect driver-side side air bag sensor connector.</li> <li>• Inspect wiring harness between terminal 1B of SAS control module connector and terminal A of driver-side side air bag sensor connector, between terminal 1D of SAS control module connector and terminal B of driver-side side air bag sensor connector, between terminal 1F of SAS control module connector and terminal C of driver-side side air bag sensor connector, and between terminal 1E of SAS control module connector and terminal D of driver-side side air bag sensor connector for following. <ul style="list-style-type: none"> <li>— Short to ground</li> <li>— Short to power supply</li> <li>— Open circuit</li> </ul> </li> <li>• Are wiring harnesses okay?</li> </ul>	<p>Yes</p> <p><b>Present malfunction diagnosis:</b></p> <ul style="list-style-type: none"> <li>• Go to next step.</li> </ul> <p><b>Past malfunction diagnosis:</b></p> <ul style="list-style-type: none"> <li>• Replace driver-side side air bag sensor. (See 08-10-10 SIDE AIR BAG SENSOR REMOVAL/ INSTALLATION)</li> </ul> <p>No</p> <p>Replace wiring harness.</p>
3	<p><b>INSPECT GROUND CIRCUIT IN SAS CONTROL MODULE</b></p> <ul style="list-style-type: none"> <li>• Is there continuity between terminal 1F and 2Q of SAS control module?</li> </ul>	<p>Yes</p> <p>Go to next step.</p> <p>No</p> <p>Replace SAS control module. (See 08-10-12 SAS CONTROL MODULE REMOVAL/ INSTALLATION)</p>
4	<p><b>INSPECT POWER SUPPLY CIRCUIT OF DRIVER-SIDE SIDE AIR BAG SENSOR</b></p> <ul style="list-style-type: none"> <li>• Connect all SAS control module connectors.</li> <li>• Connect clock spring connector.</li> <li>• Connect passenger-side air bag module connector.</li> <li>• Connect driver- and passenger-side side air bag module connectors.</li> <li>• Connect driver- and passenger-side pre-tensioner seat belt connectors.</li> <li>• Connect negative battery cable.</li> <li>• Turn ignition switch to ON position.</li> <li>• Measure voltage at terminal A of driver-side side air bag sensor connector.</li> <li>• Is voltage <b>approximately 5 V</b>?</li> </ul>	<p>Yes</p> <p>Replace driver-side side air bag sensor, then go to next step. (See 08-10-10 SIDE AIR BAG SENSOR REMOVAL/ INSTALLATION)</p> <p>No</p> <p>Replace SAS control module. (See 08-10-12 SAS CONTROL MODULE REMOVAL/ INSTALLATION)</p>

## ON-BOARD DIAGNOSTIC



STEP	INSPECTION	ACTION				
5	<p><b>VERIFY WHETHER SAS CONTROL MODULE IS MALFUNCTIONING OR NOT</b></p> <ul style="list-style-type: none"> <li>• Connect driver-side side air bag sensor connector.</li> <li>• Connect negative battery cable.</li> <li>• Turn ignition switch to ON position.</li> <li>• Is DTC 22 indicated?</li> </ul>	<table border="0" style="width: 100%;"> <tr> <td style="width: 50px; vertical-align: top;">Yes</td> <td>Replace SAS control module. (See 08-10-12 SAS CONTROL MODULE REMOVAL/INSTALLATION)</td> </tr> <tr> <td style="vertical-align: top;">No</td> <td>Complete inspection by DTC.</td> </tr> </table>	Yes	Replace SAS control module. (See 08-10-12 SAS CONTROL MODULE REMOVAL/INSTALLATION)	No	Complete inspection by DTC.
Yes	Replace SAS control module. (See 08-10-12 SAS CONTROL MODULE REMOVAL/INSTALLATION)					
No	Complete inspection by DTC.					
6	<p><b>VERIFY THAT SAS CONTROL MODULE CONNECTOR TERMINAL 2AA IS GROUNDED</b></p> <p><b>Warning</b></p> <ul style="list-style-type: none"> <li>• <b>Handling air bag system components improperly can accidentally deploy air bag modules and pre-tensioner seat belts, which may seriously injure you. Read AIR BAG SYSTEM SERVICE WARNINGS before handling air bag system components. (See 08-10-3 AIR BAG SYSTEM SERVICE WARNINGS)</b></li> </ul> <ul style="list-style-type: none"> <li>• Turn ignition switch to LOCK position.</li> <li>• Disconnect negative battery cable and wait for <b>more than 1 minute</b>.</li> <li>• Remove column cover.</li> <li>• Disconnect clock spring connector.</li> <li>• Remove glove compartment.</li> <li>• Disconnect passenger-side air bag module connector.</li> <li>• Remove B-pillar lower trims.</li> <li>• Disconnect driver-and passenger-side pre-tensioner seat belt connectors.</li> <li>• Remove left side side wall.</li> <li>• Disconnect all SAS control module connectors.</li> <li>• Disconnect driver-side side air bag sensor connector.</li> <li>• Inspect wiring harness between terminal 2AA of SAS control module connector and ground for following. <ul style="list-style-type: none"> <li>— Short to power supply</li> <li>— Open circuit</li> </ul> </li> <li>• Is wiring harnesses okay?</li> </ul>	<table border="0" style="width: 100%;"> <tr> <td style="width: 50px; vertical-align: top;">Yes</td> <td> <p><b>Present malfunction diagnosis:</b></p> <ul style="list-style-type: none"> <li>• Replace SAS control module. (See 08-10-12 SAS CONTROL MODULE REMOVAL/INSTALLATION)</li> </ul> <p><b>Past malfunction diagnosis:</b></p> <ul style="list-style-type: none"> <li>• Complete inspection by DTC.</li> </ul> </td> </tr> <tr> <td style="vertical-align: top;">No</td> <td>Replace wiring harness.</td> </tr> </table>	Yes	<p><b>Present malfunction diagnosis:</b></p> <ul style="list-style-type: none"> <li>• Replace SAS control module. (See 08-10-12 SAS CONTROL MODULE REMOVAL/INSTALLATION)</li> </ul> <p><b>Past malfunction diagnosis:</b></p> <ul style="list-style-type: none"> <li>• Complete inspection by DTC.</li> </ul>	No	Replace wiring harness.
Yes	<p><b>Present malfunction diagnosis:</b></p> <ul style="list-style-type: none"> <li>• Replace SAS control module. (See 08-10-12 SAS CONTROL MODULE REMOVAL/INSTALLATION)</li> </ul> <p><b>Past malfunction diagnosis:</b></p> <ul style="list-style-type: none"> <li>• Complete inspection by DTC.</li> </ul>					
No	Replace wiring harness.					

08-02

# ON-BOARD DIAGNOSTIC

DTC 25

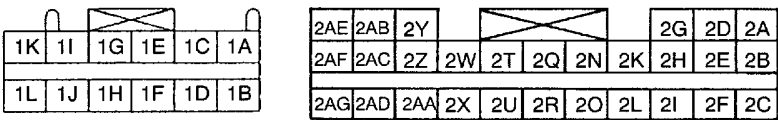
A3U080201046W12

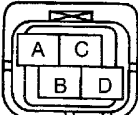
<b>DTC 25</b>	<b>Driver-side side air bag sensor system (Communication error)</b>
<b>DETECTION CONDITION</b>	<p><b>Warning</b></p> <ul style="list-style-type: none"> <li>Detection conditions are for understanding DTC outline before performing inspection. Performing inspection with only detection conditions may cause injury due to operating error or damage the system. When performing inspection, always follow diagnostic procedure.</li> </ul> <p><b>Note</b></p> <ul style="list-style-type: none"> <li>For vehicles without side air bag, DTC 22, 25, 26, 32, 35, or 37 may be indicated concurrently. In such a case, perform only the smallest DTC troubleshooting among them.</li> </ul> <p><b>Vehicles with side air bag</b></p> <ul style="list-style-type: none"> <li>Malfunction in wiring harness between driver-side side air bag sensor and SAS control module.</li> <li>Malfunction in driver-side side air bag sensor circuit.</li> </ul> <p><b>Vehicles without side air bag</b></p> <ul style="list-style-type: none"> <li>Terminal 2AA of SAS control module connector is open.</li> </ul>
<b>POSSIBLE CAUSE</b>	<p><b>Vehicles with side air bag</b></p> <ul style="list-style-type: none"> <li>Driver-side side air bag sensor malfunction.</li> <li>Open or short circuit in wiring harness between driver-side side air bag sensor and SAS control module.</li> <li>SAS control module malfunction.</li> </ul> <p><b>Vehicles without side air bag</b></p> <ul style="list-style-type: none"> <li>Malfunction of connector between SAS control module and ground.</li> <li>Open or short circuit in wiring harness between SAS control module and ground.</li> <li>SAS control module malfunction.</li> </ul>
<p><b>SAS CONTROL MODULE CONNECTOR</b></p>  <p style="text-align: center;"><b>HARNESS SIDE CONNECTOR (VIEW FROM HARNESS SIDE)</b></p> <div style="display: flex; justify-content: space-around; margin-top: 20px;"> <div style="text-align: center;"> <p><b>DRIVER-SIDE SIDE AIR BAG SENSOR</b></p>  <p><b>COMPONENT SIDE CONNECTOR (VIEW FROM TERMINAL SIDE)</b></p> </div> <div style="text-align: center;"> <p><b>DRIVER-SIDE SIDE AIR BAG SENSOR CONNECTOR</b></p>  <p><b>HARNESS SIDE CONNECTOR (VIEW FROM TERMINAL SIDE)</b></p> </div> </div>	

**Diagnostic procedure**

STEP	INSPECTION	ACTION				
1	<ul style="list-style-type: none"> <li>Is vehicle equipped with side air bag?</li> </ul>	<table style="width: 100%; border-collapse: collapse;"> <tr> <td style="width: 10%; text-align: center;">Yes</td> <td>Go to next step.</td> </tr> <tr> <td style="text-align: center;">No</td> <td>Go to Step 5.</td> </tr> </table>	Yes	Go to next step.	No	Go to Step 5.
Yes	Go to next step.					
No	Go to Step 5.					

## ON-BOARD DIAGNOSTIC

STEP	INSPECTION	ACTION	
2	<p><b>INSPECT WIRING HARNESS BETWEEN DRIVER-SIDE SIDE AIR BAG SENSOR AND SAS CONTROL MODULE</b></p> <p><b>Warning</b></p> <ul style="list-style-type: none"> <li>• <b>Handling air bag system components improperly can accidentally deploy air bag modules and pre-tensioner seat belts, which may seriously injure you. Read AIR BAG SYSTEM SERVICE WARNINGS before handling air bag system components. (See 08-10-3 AIR BAG SYSTEM SERVICE WARNINGS)</b></li> </ul> <ul style="list-style-type: none"> <li>• Turn ignition switch to LOCK position.</li> <li>• Disconnect negative battery cable and wait for <b>more than 1 minute</b>.</li> <li>• Remove column cover.</li> <li>• Disconnect clock spring connector.</li> <li>• Remove glove compartment.</li> <li>• Disconnect passenger-side air bag module connector.</li> <li>• Disconnect driver- and passenger-side side air bag module connectors.</li> <li>• Remove B-pillar lower trims.</li> <li>• Disconnect driver- and passenger-side pre-tensioner seat belt connectors.</li> <li>• Remove left side side wall.</li> <li>• Disconnect all SAS control module connectors.</li> <li>• Disconnect driver-side side air bag sensor connector.</li> <li>• Inspect following wiring harness between SAS control module connector and driver-side side air bag sensor connector terminals (harness side) for short to ground, short to power supply, and open circuit: <ul style="list-style-type: none"> <li>— 1B and A</li> <li>— 1D and B</li> <li>— 1F and C</li> <li>— 1E and D</li> </ul> </li> <li>• Are wiring harnesses okay?</li> </ul>	Yes	<p><b>Present malfunction diagnosis:</b></p> <ul style="list-style-type: none"> <li>• Go to next step.</li> </ul> <p><b>Past malfunction diagnosis:</b></p> <ul style="list-style-type: none"> <li>• Replace SAS control module. (See 08-10-12 SAS CONTROL MODULE REMOVAL/ INSTALLATION)</li> </ul>
		No	Replace wiring harness.
3	<p><b>INSPECT DRIVER-SIDE SIDE AIR BAG SENSOR</b></p> <ul style="list-style-type: none"> <li>• Measure resistance between terminals C and D of driver-side side air bag sensor.</li> <li>• Is resistance <b>approximately 1 kilohm</b>?</li> </ul>	Yes	Replace SAS control module, then go to next step. (See 08-10-12 SAS CONTROL MODULE REMOVAL/ INSTALLATION)
		No	Replace driver-side side air bag sensor. (See 08-10-10 SIDE AIR BAG SENSOR REMOVAL/ INSTALLATION)
4	<p><b>VERIFY WHETHER DRIVER-SIDE SIDE AIR BAG SENSOR IS MALFUNCTIONING OR NOT</b></p> <ul style="list-style-type: none"> <li>• Connect all SAS control module connectors and driver-side side air bag sensor connector.</li> <li>• Connect clock spring connector. Connect passenger-side air bag module connector.</li> <li>• Connect driver- and passenger-side side air bag module connectors.</li> <li>• Connect driver- and passenger-side pre-tensioner seat belt connectors.</li> <li>• Connect negative battery cable.</li> <li>• Turn ignition switch to ON position.</li> <li>• Is DTC 25 indicated?</li> </ul>	Yes	Replace driver-side side air bag sensor. (See 08-10-10 SIDE AIR BAG SENSOR REMOVAL/ INSTALLATION)
		No	Complete inspection by DTC.

08-02

## ON-BOARD DIAGNOSTIC

STEP	INSPECTION	ACTION				
5	<p><b>VERIFY THAT SAS CONTROL MODULE CONNECTOR TERMINAL 2AA IS GROUNDED</b></p> <p><b>Warning</b></p> <ul style="list-style-type: none"> <li>• <b>Handling air bag system components improperly can accidentally deploy air bag modules and pre-tensioner seat belts, which may seriously injure you. Read AIR BAG SYSTEM SERVICE WARNINGS before handling air bag system components. (See 08–10–3 AIR BAG SYSTEM SERVICE WARNINGS)</b></li> </ul> <ul style="list-style-type: none"> <li>• Turn ignition switch to LOCK position.</li> <li>• Disconnect negative battery cable and wait for <b>more than 1 minute</b>.</li> <li>• Remove column cover.</li> <li>• Disconnect clock spring connector.</li> <li>• Remove glove compartment.</li> <li>• Disconnect passenger-side air bag module connector.</li> <li>• Remove B-pillar lower trims.</li> <li>• Disconnect driver-and passenger-side pre-tensioner seat belt connectors.</li> <li>• Remove left side side wall.</li> <li>• Disconnect all SAS control module connectors.</li> <li>• Disconnect driver-side side air bag sensor connector.</li> <li>• Inspect wiring harness between terminal 2AA of SAS control module connector and ground for following. <ul style="list-style-type: none"> <li>— Short to power supply</li> <li>— Open circuit</li> </ul> </li> <li>• Is wiring harnesses okay?</li> </ul>	<table border="1" style="width: 100%; border-collapse: collapse;"> <tr> <td style="text-align: center; width: 50px;">Yes</td> <td> <p><b>Present malfunction diagnosis:</b></p> <ul style="list-style-type: none"> <li>• Replace SAS control module. (See 08–10–12 SAS CONTROL MODULE REMOVAL/INSTALLATION)</li> </ul> <p><b>Past malfunction diagnosis:</b></p> <ul style="list-style-type: none"> <li>• Complete inspection by DTC.</li> </ul> </td> </tr> <tr> <td style="text-align: center;">No</td> <td> <p>Replace wiring harness.</p> </td> </tr> </table>	Yes	<p><b>Present malfunction diagnosis:</b></p> <ul style="list-style-type: none"> <li>• Replace SAS control module. (See 08–10–12 SAS CONTROL MODULE REMOVAL/INSTALLATION)</li> </ul> <p><b>Past malfunction diagnosis:</b></p> <ul style="list-style-type: none"> <li>• Complete inspection by DTC.</li> </ul>	No	<p>Replace wiring harness.</p>
Yes	<p><b>Present malfunction diagnosis:</b></p> <ul style="list-style-type: none"> <li>• Replace SAS control module. (See 08–10–12 SAS CONTROL MODULE REMOVAL/INSTALLATION)</li> </ul> <p><b>Past malfunction diagnosis:</b></p> <ul style="list-style-type: none"> <li>• Complete inspection by DTC.</li> </ul>					
No	<p>Replace wiring harness.</p>					

### DTC 26

A3U080201046W13

DTC 26	Driver-side side air bag module system
<b>DETECTION CONDITION</b>	<p><b>Warning</b></p> <ul style="list-style-type: none"> <li>• <b>Detection conditions are for understanding DTC outline before performing inspection. Performing inspection with only detection conditions may cause injury due to operating error or damage the system. When performing inspection, always follow diagnostic procedure.</b></li> </ul> <p><b>Note</b></p> <ul style="list-style-type: none"> <li>• For vehicles without side air bag, DTC 22, 25, 26, 32, 35, or 37 may be indicated concurrently. In such a case, perform only the smallest DTC troubleshooting among them.</li> </ul> <p><b>Vehicles with side air bag</b></p> <ul style="list-style-type: none"> <li>• Resistance detected between terminals 1A and 1C of SAS control module is other than <b>1.63—2.71 ohm</b>.</li> <li>• Short circuit in wiring harness related terminal 1A or 1C of SAS control module.</li> </ul> <p><b>Vehicles without side air bag</b></p> <ul style="list-style-type: none"> <li>• Terminal 2AA of SAS control module connector is open.</li> </ul>
<b>POSSIBLE CAUSE</b>	<p><b>Vehicles with side air bag</b></p> <ul style="list-style-type: none"> <li>• Driver-side side air bag module malfunction.</li> <li>• Malfunction of connectors between driver-side side air bag module and SAS control module.</li> <li>• Open or short circuit in wiring harness between driver-side side air bag module and SAS control module.</li> <li>• SAS control module malfunction.</li> </ul> <p><b>Vehicles without side air bag</b></p> <ul style="list-style-type: none"> <li>• Malfunction of connector between SAS control module and ground.</li> <li>• Open or short circuit in wiring harness between SAS control module and ground.</li> <li>• SAS control module malfunction.</li> </ul>

# ON-BOARD DIAGNOSTIC

DRIVER-SIDE SIDE AIR BAG  
MODULE CONNECTOR

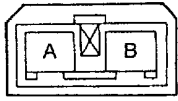

HARNESS SIDE CONNECTOR  
(VIEW FROM TERMINAL SIDE)

SAS CONTROL MODULE CONNECTOR

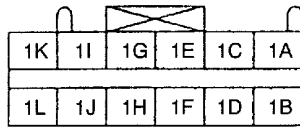

HARNESS SIDE CONNECTOR  
(VIEW FROM HARNESS SIDE)

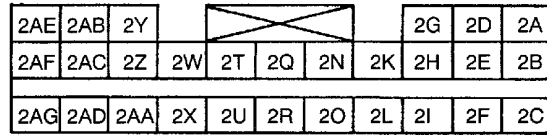

HARNESS SIDE CONNECTOR  
(VIEW FROM HARNESS SIDE)

## Diagnostic procedure

STEP	INSPECTION	ACTION
1	<ul style="list-style-type: none"> <li>Is vehicle equipped with side air bag?</li> </ul>	Yes: Go to next step. No: Go to Step 5.
2	<p><b>INSPECT SEPARATOR* OF DRIVER-SIDE SIDE AIR BAG MODULE CONNECTOR</b></p> <p><b>Warning</b></p> <ul style="list-style-type: none"> <li>Handling air bag system components improperly can accidentally deploy air bag modules and pre-tensioner seat belts, which may seriously injure you. Read AIR BAG SYSTEM SERVICE WARNINGS before handling air bag system components. (See 08-10-3 AIR BAG SYSTEM SERVICE WARNINGS)</li> </ul> <ul style="list-style-type: none"> <li>Turn ignition switch to LOCK position.</li> <li>Disconnect negative battery cable and wait for <b>more than 1 minute</b>.</li> <li>Disconnect driver-side side air bag module connector.</li> <li>Is separator* of driver-side side air bag module connector okay?</li> </ul>	Yes: <b>Present malfunction diagnosis:</b> <ul style="list-style-type: none"> <li>Go to next step.</li> </ul> <b>Past malfunction diagnosis:</b> <ul style="list-style-type: none"> <li>Go to Step 3.</li> </ul> No: Replace wiring harness.
3	<p><b>VERIFY WHETHER MALFUNCTION IS IN DRIVER-SIDE SIDE AIR BAG MODULE OR OTHER PARTS</b></p> <ul style="list-style-type: none"> <li>Connect leads of <b>SST</b> (Fuel And Thermometer checker) or apply <b>2 ohms</b> resistor to driver-side side air bag module connector terminals A and B.</li> <li>Set resistance of <b>SST</b> (Fuel And Thermometer checker) to <b>2 ohms</b>.</li> <li>Connect negative battery cable.</li> <li>Turn ignition switch to ON position.</li> <li>Is DTC 26 indicated?</li> </ul>	Yes: Go to next step. No: Replace driver-side side air bag module. (See 08-10-7 SIDE AIR BAG MODULE REMOVAL/ INSTALLATION)

08-02

## ON-BOARD DIAGNOSTIC

STEP	INSPECTION	ACTION
4	<p><b>INSPECT WIRING HARNESS BETWEEN DRIVER-SIDE SIDE AIR BAG MODULE AND SAS CONTROL MODULE</b></p> <ul style="list-style-type: none"> <li>• Turn ignition switch to LOCK position.</li> <li>• Disconnect negative battery cable and wait for <b>more than 1 minute</b>.</li> <li>• Remove column cover.</li> <li>• Disconnect clock spring connector.</li> <li>• Remove glove compartment.</li> <li>• Disconnect passenger-side air bag module connector.</li> <li>• Disconnect passenger-side side air bag module connector.</li> <li>• Remove B-pillar lower trims.</li> <li>• Disconnect driver-and passenger-side pre-tensioner seat belt connectors.</li> <li>• Remove left side side wall.</li> <li>• Disconnect all SAS control module connectors.</li> <li>• Inspect following wiring harness between SAS control module connector and driver-side side air bag module connector terminals (harness side) for short to ground, short to power supply, and open circuit:                             <ul style="list-style-type: none"> <li>— 1A and A</li> <li>— 1C and B</li> </ul> </li> <li>• Are wiring harnesses okay?</li> </ul>	<p>Yes</p> <p><b>Present malfunction diagnosis:</b></p> <ul style="list-style-type: none"> <li>• Remove SAS control module. (See 08–10–12 SAS CONTROL MODULE REMOVAL/INSTALLATION)</li> </ul> <p><b>Past malfunction diagnosis:</b></p> <ul style="list-style-type: none"> <li>• Replace driver-side side air bag module. (See 08–10–7 SIDE AIR BAG MODULE REMOVAL/INSTALLATION)</li> </ul>
		<p>No</p> <p>Replace wiring harness.</p>
5	<p><b>VERIFY THAT SAS CONTROL MODULE CONNECTOR TERMINAL 2AA IS GROUNDED</b></p> <p><b>Warning</b></p> <ul style="list-style-type: none"> <li>• <b>Handling air bag system components improperly can accidentally deploy air bag modules and pre-tensioner seat belts, which may seriously injure you. Read AIR BAG SYSTEM SERVICE WARNINGS before handling air bag system components. (See 08–10–3 AIR BAG SYSTEM SERVICE WARNINGS)</b></li> </ul> <ul style="list-style-type: none"> <li>• Turn ignition switch to LOCK position.</li> <li>• Disconnect negative battery cable and wait for <b>more than 1 minute</b>.</li> <li>• Remove column cover.</li> <li>• Disconnect clock spring connector.</li> <li>• Remove glove compartment.</li> <li>• Disconnect passenger-side air bag module connector.</li> <li>• Remove B-pillar lower trims.</li> <li>• Disconnect driver-and passenger-side pre-tensioner seat belt connectors.</li> <li>• Remove left side side wall.</li> <li>• Disconnect all SAS control module connectors.</li> <li>• Disconnect driver-side side air bag sensor connector.</li> <li>• Inspect wiring harness between terminal 2AA of SAS control module connector and ground for following.                             <ul style="list-style-type: none"> <li>— Short to power supply</li> <li>— Open circuit</li> </ul> </li> <li>• Is wiring harnesses okay?</li> </ul>	<p>Yes</p> <p><b>Present malfunction diagnosis:</b></p> <ul style="list-style-type: none"> <li>• Replace SAS control module. (See 08–10–12 SAS CONTROL MODULE REMOVAL/INSTALLATION)</li> </ul> <p><b>Past malfunction diagnosis:</b></p> <ul style="list-style-type: none"> <li>• Complete inspection by DTC.</li> </ul>
		<p>No</p> <p>Replace wiring harness.</p>

\* : Consists of the 2 parts of the female connector that separate the short bar from the terminal when connected to the male connector.



# ON-BOARD DIAGNOSTIC

DTC 32

A3U080201046W14

<b>DTC 32</b>	<b>Passenger-side side air bag sensor system (Internal circuit abnormal)</b>
<b>DETECTION CONDITION</b>	<p><b>Warning</b></p> <ul style="list-style-type: none"> <li>Detection conditions are for understanding DTC outline before performing inspection. Performing inspection with only detection conditions may cause injury due to operating error or damage the system. When performing inspection, always follow diagnostic procedure.</li> </ul> <p><b>Note</b></p> <ul style="list-style-type: none"> <li>For vehicles without side air bag, DTC 22, 25, 26, 32, 35, or 37 may be indicated concurrently. In such a case, perform only the smallest DTC troubleshooting among them.</li> </ul> <p><b>Vehicles with side air bag</b></p> <ul style="list-style-type: none"> <li>Malfunction in wiring harness between passenger-side side air bag sensor and SAS control module.</li> <li>Malfunction in passenger-side side air bag sensor circuit.</li> </ul> <p><b>Vehicles without side air bag</b></p> <ul style="list-style-type: none"> <li>Terminal 2AA of SAS control module connector is open.</li> </ul>
<b>POSSIBLE CAUSE</b>	<p><b>Vehicles with side air bag</b></p> <ul style="list-style-type: none"> <li>Passenger-side side air bag sensor malfunction.</li> <li>Open or short circuit in wiring harness between passenger-side side air bag sensor and SAS control module.</li> <li>SAS control module malfunction.</li> </ul> <p><b>Vehicles without side air bag</b></p> <ul style="list-style-type: none"> <li>Malfunction of connector between SAS control module and ground.</li> <li>Open or short circuit in wiring harness between SAS control module and ground.</li> <li>SAS control module malfunction.</li> </ul>

08-02

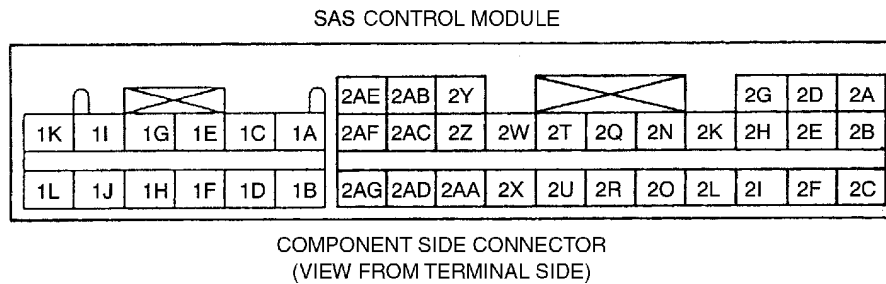
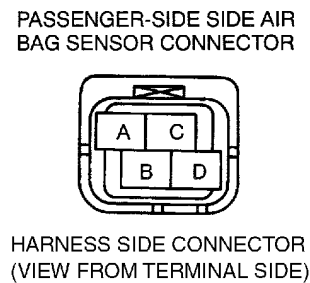
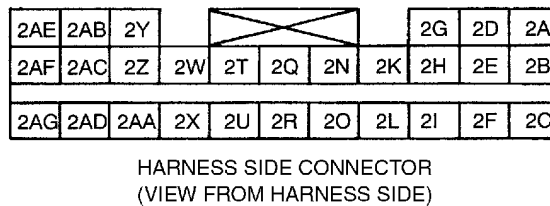
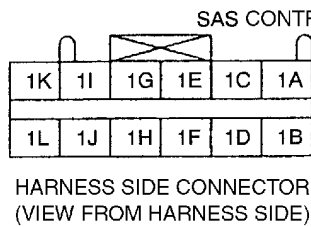

**Diagnostic procedure**

STEP	INSPECTION	ACTION				
1	<ul style="list-style-type: none"> <li>Is vehicle equipped with side air bag?</li> </ul>	<table style="width: 100%; border-collapse: collapse;"> <tr> <td style="width: 10%; text-align: center;">Yes</td> <td>Go to next step.</td> </tr> <tr> <td style="text-align: center;">No</td> <td>Go to Step 6.</td> </tr> </table>	Yes	Go to next step.	No	Go to Step 6.
Yes	Go to next step.					
No	Go to Step 6.					

## ON-BOARD DIAGNOSTIC

STEP	INSPECTION	ACTION
2	<p><b>INSPECT WIRING HARNESS BETWEEN PASSENGER-SIDE SIDE AIR BAG SENSOR AND SAS CONTROL MODULE</b></p> <p><b>Warning</b></p> <ul style="list-style-type: none"> <li>• <b>Handling air bag system components improperly can accidentally deploy air bag modules and pre-tensioner seat belts, which may seriously injure you. Read AIR BAG SYSTEM SERVICE WARNINGS before handling air bag system components. (See 08-10-3 AIR BAG SYSTEM SERVICE WARNINGS)</b></li> </ul> <ul style="list-style-type: none"> <li>• Turn ignition switch to LOCK position.</li> <li>• Disconnect negative battery cable and wait for <b>more than 1 minute</b>.</li> <li>• Remove column cover.</li> <li>• Disconnect clock spring connector.</li> <li>• Remove glove compartment.</li> <li>• Disconnect passenger-side air bag module connector.</li> <li>• Disconnect driver- and passenger-side side air bag module connectors.</li> <li>• Remove B-pillar lower trims.</li> <li>• Disconnect driver-and passenger-side pre-tensioner seat belt connectors.</li> <li>• Remove left side side wall.</li> <li>• Disconnect all SAS control module connectors.</li> <li>• Disconnect passenger-side side air bag sensor connector.</li> <li>• Inspect wiring harness between terminal 1L of SAS control module connector and terminal A of passenger-side side air bag sensor connector, between terminal 1J of SAS control module connector and terminal B of passenger-side side air bag sensor connector, between terminal 1H of SAS control module connector and terminal C of passenger-side side air bag sensor connector, and between terminal 1G of SAS control module connector and terminal D of passenger-side side air bag sensor connector for following. <ul style="list-style-type: none"> <li>— Short to ground</li> <li>— Short to power supply</li> <li>— Open circuit</li> </ul> </li> <li>• Are wiring harnesses okay?</li> </ul>	<p>Yes</p> <p><b>Present malfunction diagnosis:</b></p> <ul style="list-style-type: none"> <li>• Go to next step.</li> </ul> <p><b>Past malfunction diagnosis:</b></p> <ul style="list-style-type: none"> <li>• Replace passenger-side side air bag sensor. (See 08-10-10 SIDE AIR BAG SENSOR REMOVAL/INSTALLATION)</li> </ul> <p>No</p> <p>Replace wiring harness.</p>
3	<p><b>INSPECT GROUND CIRCUIT IN SAS CONTROL MODULE</b></p> <ul style="list-style-type: none"> <li>• Is there continuity between terminal 1H and 2Q of SAS control module?</li> </ul>	<p>Yes</p> <p>Go to next step.</p> <p>No</p> <p>Replace SAS control module. (See 08-10-12 SAS CONTROL MODULE REMOVAL/INSTALLATION)</p>
4	<p><b>INSPECT POWER SUPPLY CIRCUIT OF PASSENGER-SIDE SIDE AIR BAG SENSOR</b></p> <ul style="list-style-type: none"> <li>• Connect all SAS control module connectors.</li> <li>• Connect clock spring connector.</li> <li>• Connect passenger-side air bag module connector.</li> <li>• Connect driver- and passenger-side side air bag module connectors.</li> <li>• Connect driver- and passenger-side pre-tensioner seat belt connectors.</li> <li>• Connect negative battery cable.</li> <li>• Turn ignition switch to ON position.</li> <li>• Measure voltage at terminal A of passenger-side side air bag sensor connector.</li> <li>• Is voltage <b>approximately 5 V</b>?</li> </ul>	<p>Yes</p> <p>Replace passenger-side side air bag sensor, then go to next step. (See 08-10-10 SIDE AIR BAG SENSOR REMOVAL/INSTALLATION)</p> <p>No</p> <p>Replace SAS control module. (See 08-10-12 SAS CONTROL MODULE REMOVAL/INSTALLATION)</p>

## ON-BOARD DIAGNOSTIC

STEP	INSPECTION	ACTION				
5	<p><b>VERIFY WHETHER SAS CONTROL MODULE IS MALFUNCTIONING OR NOT</b></p> <ul style="list-style-type: none"> <li>• Connect passenger-side side air bag sensor connector.</li> <li>• Connect negative battery cable.</li> <li>• Turn ignition switch to ON position.</li> <li>• Is DTC 32 indicated?</li> </ul>	<table border="0" style="width: 100%;"> <tr> <td style="width: 50px; vertical-align: top;">Yes</td> <td>Replace SAS control module. (See 08-10-12 SAS CONTROL MODULE REMOVAL/INSTALLATION)</td> </tr> <tr> <td style="vertical-align: top;">No</td> <td>Complete inspection by DTC.</td> </tr> </table>	Yes	Replace SAS control module. (See 08-10-12 SAS CONTROL MODULE REMOVAL/INSTALLATION)	No	Complete inspection by DTC.
Yes	Replace SAS control module. (See 08-10-12 SAS CONTROL MODULE REMOVAL/INSTALLATION)					
No	Complete inspection by DTC.					
6	<p><b>VERIFY THAT SAS CONTROL MODULE CONNECTOR TERMINAL 2AA IS GROUNDED</b></p> <p><b>Warning</b></p> <ul style="list-style-type: none"> <li>• <b>Handling air bag system components improperly can accidentally deploy air bag modules and pre-tensioner seat belts, which may seriously injure you. Read AIR BAG SYSTEM SERVICE WARNINGS before handling air bag system components. (See 08-10-3 AIR BAG SYSTEM SERVICE WARNINGS)</b></li> </ul> <ul style="list-style-type: none"> <li>• Turn ignition switch to LOCK position.</li> <li>• Disconnect negative battery cable and wait for <b>more than 1 minute</b>.</li> <li>• Remove column cover.</li> <li>• Disconnect clock spring connector.</li> <li>• Remove glove compartment. (Vehicles with passenger-side air bag)</li> <li>• Disconnect passenger-side air bag module connector. (Vehicles with passenger-side air bag)</li> <li>• Remove B-pillar lower trims.</li> <li>• Disconnect driver-and passenger-side pre-tensioner seat belt connectors.</li> <li>• Remove left side side wall.</li> <li>• Disconnect all SAS control module connectors.</li> <li>• Disconnect driver-side side air bag sensor connector.</li> <li>• Inspect wiring harness between terminal 2AA of SAS control module connector and ground for following. <ul style="list-style-type: none"> <li>— Short to power supply</li> <li>— Open circuit</li> </ul> </li> <li>• Is wiring harnesses okay?</li> </ul>	<table border="0" style="width: 100%;"> <tr> <td style="width: 50px; vertical-align: top;">Yes</td> <td> <p><b>Present malfunction diagnosis:</b></p> <ul style="list-style-type: none"> <li>• Replace SAS control module. (See 08-10-12 SAS CONTROL MODULE REMOVAL/INSTALLATION)</li> </ul> <p><b>Past malfunction diagnosis:</b></p> <ul style="list-style-type: none"> <li>• Complete inspection by DTC.</li> </ul> </td> </tr> <tr> <td style="vertical-align: top;">No</td> <td>Replace wiring harness.</td> </tr> </table>	Yes	<p><b>Present malfunction diagnosis:</b></p> <ul style="list-style-type: none"> <li>• Replace SAS control module. (See 08-10-12 SAS CONTROL MODULE REMOVAL/INSTALLATION)</li> </ul> <p><b>Past malfunction diagnosis:</b></p> <ul style="list-style-type: none"> <li>• Complete inspection by DTC.</li> </ul>	No	Replace wiring harness.
Yes	<p><b>Present malfunction diagnosis:</b></p> <ul style="list-style-type: none"> <li>• Replace SAS control module. (See 08-10-12 SAS CONTROL MODULE REMOVAL/INSTALLATION)</li> </ul> <p><b>Past malfunction diagnosis:</b></p> <ul style="list-style-type: none"> <li>• Complete inspection by DTC.</li> </ul>					
No	Replace wiring harness.					

08-02

# ON-BOARD DIAGNOSTIC

DTC 35

A3U080201046W15

<b>DTC 35</b>	<b>Passenger-side side air bag sensor system (Communication error)</b>
<b>DETECTION CONDITION</b>	<p><b>Warning</b></p> <ul style="list-style-type: none"> <li>Detection conditions are for understanding DTC outline before performing inspection. Performing inspection with only detection conditions may cause injury due to operating error or damage the system. When performing inspection, always follow diagnostic procedure.</li> </ul> <p><b>Note</b></p> <ul style="list-style-type: none"> <li>For vehicles without side air bag, DTC 22, 25, 26, 32, 35, or 37 may be indicated concurrently. In such a case, perform only the smallest DTC troubleshooting among them.</li> </ul> <p><b>Vehicles with side air bag</b></p> <ul style="list-style-type: none"> <li>Malfunction in wiring harness between passenger-side side air bag sensor and SAS control module.</li> <li>Malfunction in passenger-side side air bag sensor circuit.</li> </ul> <p><b>Vehicles without side air bag</b></p> <ul style="list-style-type: none"> <li>Terminal 2AA of SAS control module connector is open.</li> </ul>

<b>POSSIBLE CAUSE</b>	<p><b>Vehicles with side air bag</b></p> <ul style="list-style-type: none"> <li>Passenger-side side air bag sensor malfunction.</li> <li>Open or short circuit in wiring harness between passenger-side side air bag sensor and SAS control module.</li> <li>SAS control module malfunction.</li> </ul> <p><b>Vehicles without side air bag</b></p> <ul style="list-style-type: none"> <li>Malfunction of connector between SAS control module and ground.</li> <li>Open or short circuit in wiring harness between SAS control module and ground.</li> <li>SAS control module malfunction.</li> </ul>
-----------------------	--

SAS CONTROL MODULE CONNECTOR

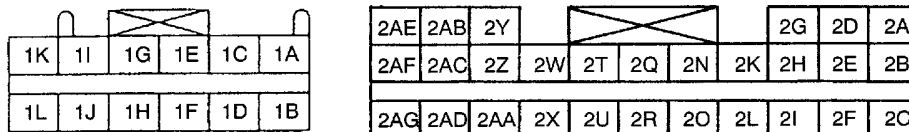

HARNESS SIDE CONNECTOR  
(VIEW FROM HARNESS SIDE)

PASSENGER-SIDE  
SIDE AIR BAG SENSOR



COMPONENT SIDE CONNECTOR  
(VIEW FROM TERMINAL SIDE)

PASSENGER-SIDE SIDE AIR  
BAG SENSOR CONNECTOR

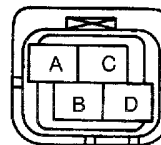

HARNESS SIDE CONNECTOR  
(VIEW FROM TERMINAL SIDE)

**Diagnostic procedure**

STEP	INSPECTION	ACTION				
1	<ul style="list-style-type: none"> <li>Is vehicle equipped with side air bag?</li> </ul>	<table style="width: 100%; border-collapse: collapse;"> <tr> <td style="width: 10%; text-align: center;">Yes</td> <td>Go to next step.</td> </tr> <tr> <td style="text-align: center;">No</td> <td>Go to Step 5.</td> </tr> </table>	Yes	Go to next step.	No	Go to Step 5.
Yes	Go to next step.					
No	Go to Step 5.					

## ON-BOARD DIAGNOSTIC

STEP	INSPECTION	ACTION	
2	<p><b>INSPECT WIRING HARNESS BETWEEN PASSENGER-SIDE SIDE AIR BAG SENSOR AND SAS CONTROL MODULE</b></p> <p><b>Warning</b></p> <ul style="list-style-type: none"> <li>• <b>Handling air bag system components improperly can accidentally deploy air bag modules and pre-tensioner seat belts, which may seriously injure you. Read AIR BAG SYSTEM SERVICE WARNINGS before handling air bag system components. (See 08-10-3 AIR BAG SYSTEM SERVICE WARNINGS)</b></li> </ul> <ul style="list-style-type: none"> <li>• Turn ignition switch to LOCK position.</li> <li>• Disconnect negative battery cable and wait for <b>more than 1 minute</b>.</li> <li>• Remove column cover.</li> <li>• Disconnect clock spring connector.</li> <li>• Remove glove compartment.</li> <li>• Disconnect passenger-side air bag module connector.</li> <li>• Disconnect driver- and passenger-side side air bag module connectors.</li> <li>• Remove B-pillar lower trims.</li> <li>• Disconnect driver- and passenger-side pre-tensioner seat belt connectors.</li> <li>• Remove left side side wall.</li> <li>• Disconnect all SAS control module connectors.</li> <li>• Disconnect passenger-side side air bag sensor connector.</li> <li>• Inspect following wiring harness between SAS control module connector and passenger-side side air bag sensor connector terminals (harness side) for short to ground, short to power supply, and open circuit: <ul style="list-style-type: none"> <li>— 1L and A</li> <li>— 1J and B</li> <li>— 1H and C</li> <li>— 1G and D</li> </ul> </li> <li>• Are wiring harnesses okay?</li> </ul>	Yes	<p><b>Present malfunction diagnosis:</b></p> <ul style="list-style-type: none"> <li>• Go to next step.</li> </ul> <p><b>Past malfunction diagnosis:</b></p> <ul style="list-style-type: none"> <li>• Replace SAS control module. (See 08-10-12 SAS CONTROL MODULE REMOVAL/INSTALLATION)</li> </ul>
		No	Replace wiring harness.
3	<p><b>INSPECT PASSENGER-SIDE SIDE AIR BAG SENSOR</b></p> <ul style="list-style-type: none"> <li>• Measure resistance between terminals C and D of passenger-side side air bag sensor.</li> <li>• Is resistance <b>approximately 1 kilohm</b>?</li> </ul>	Yes	Replace SAS control module, then go to next step. (See 08-10-12 SAS CONTROL MODULE REMOVAL/INSTALLATION)
		No	Replace passenger-side side air bag sensor. (See 08-10-10 SIDE AIR BAG SENSOR REMOVAL/INSTALLATION)
4	<p><b>VERIFY WHETHER PASSENGER-SIDE SIDE AIR BAG SENSOR IS MALFUNCTIONING OR NOT</b></p> <ul style="list-style-type: none"> <li>• Connect all SAS control module connectors and passenger-side side air bag sensor connector.</li> <li>• Connect clock spring connector.</li> <li>• Connect passenger-side air bag module connector.</li> <li>• Connect driver- and passenger-side side air bag module connectors.</li> <li>• Connect driver- and passenger-side pre-tensioner seat belt connectors.</li> <li>• Connect negative battery cable.</li> <li>• Turn ignition switch to ON position.</li> <li>• Is DTC 35 indicated?</li> </ul>	Yes	Replace passenger-side side air bag sensor. (See 08-10-10 SIDE AIR BAG SENSOR REMOVAL/INSTALLATION)
		No	Complete inspection by DTC.

08-02

## ON-BOARD DIAGNOSTIC

STEP	INSPECTION	ACTION				
5	<p><b>VERIFY THAT SAS CONTROL MODULE CONNECTOR TERMINAL 2AA IS GROUNDED</b></p> <p><b>Warning</b></p> <ul style="list-style-type: none"> <li>• <b>Handling air bag system components improperly can accidentally deploy air bag modules and pre-tensioner seat belts, which may seriously injure you. Read AIR BAG SYSTEM SERVICE WARNINGS before handling air bag system components. (See 08–10–3 AIR BAG SYSTEM SERVICE WARNINGS)</b></li> </ul> <ul style="list-style-type: none"> <li>• Turn ignition switch to LOCK position.</li> <li>• Disconnect negative battery cable and wait for <b>more than 1 minute</b>.</li> <li>• Remove column cover.</li> <li>• Disconnect clock spring connector.</li> <li>• Remove glove compartment.</li> <li>• Disconnect passenger-side air bag module connector.</li> <li>• Remove B-pillar lower trims.</li> <li>• Disconnect driver-and passenger-side pre-tensioner seat belt connectors.</li> <li>• Remove left side side wall.</li> <li>• Disconnect all SAS control module connectors.</li> <li>• Disconnect driver-side side air bag sensor connector.</li> <li>• Inspect wiring harness between terminal 2AA of SAS control module connector and ground for following. <ul style="list-style-type: none"> <li>— Short to power supply</li> <li>— Open circuit</li> </ul> </li> <li>• Is wiring harnesses okay?</li> </ul>	<table border="1" style="width: 100%; border-collapse: collapse;"> <tr> <td style="text-align: center; width: 50px;">Yes</td> <td> <p><b>Present malfunction diagnosis:</b></p> <ul style="list-style-type: none"> <li>• Replace SAS control module. (See 08–10–12 SAS CONTROL MODULE REMOVAL/INSTALLATION)</li> </ul> <p><b>Past malfunction diagnosis:</b></p> <ul style="list-style-type: none"> <li>• Complete inspection by DTC.</li> </ul> </td> </tr> <tr> <td style="text-align: center;">No</td> <td> <p>Replace wiring harness.</p> </td> </tr> </table>	Yes	<p><b>Present malfunction diagnosis:</b></p> <ul style="list-style-type: none"> <li>• Replace SAS control module. (See 08–10–12 SAS CONTROL MODULE REMOVAL/INSTALLATION)</li> </ul> <p><b>Past malfunction diagnosis:</b></p> <ul style="list-style-type: none"> <li>• Complete inspection by DTC.</li> </ul>	No	<p>Replace wiring harness.</p>
Yes	<p><b>Present malfunction diagnosis:</b></p> <ul style="list-style-type: none"> <li>• Replace SAS control module. (See 08–10–12 SAS CONTROL MODULE REMOVAL/INSTALLATION)</li> </ul> <p><b>Past malfunction diagnosis:</b></p> <ul style="list-style-type: none"> <li>• Complete inspection by DTC.</li> </ul>					
No	<p>Replace wiring harness.</p>					

### DTC 37

A3U080201046W16

DTC 37	Passenger-side side air bag module system
<b>DETECTION CONDITION</b>	<p><b>Warning</b></p> <ul style="list-style-type: none"> <li>• <b>Detection conditions are for understanding DTC outline before performing inspection. Performing inspection with only detection conditions may cause injury due to operating error or damage the system. When performing inspection, always follow diagnostic procedure.</b></li> </ul> <p><b>Note</b></p> <ul style="list-style-type: none"> <li>• For vehicles without side air bag, DTC 22, 25, 26, 32, 35, or 37 may be indicated concurrently. In such a case, perform only the smallest DTC troubleshooting among them.</li> </ul> <p><b>Vehicles with side air bag</b></p> <ul style="list-style-type: none"> <li>• Resistance detected between terminals 11 and 1K of SAS control module is other than <b>1.63—2.71 ohm</b>.</li> <li>• Short circuit in wiring harness related terminal 11 or 1K of SAS control module.</li> </ul> <p><b>Vehicles without side air bag</b></p> <ul style="list-style-type: none"> <li>• Terminal 2AA of SAS control module connector is open.</li> </ul>
<b>POSSIBLE CAUSE</b>	<p><b>Vehicles with side air bag</b></p> <ul style="list-style-type: none"> <li>• Passenger-side side air bag module malfunction.</li> <li>• Malfunction of connectors between passenger-side side air bag module and SAS control module.</li> <li>• Open or short circuit in wiring harness between passenger-side side air bag module and SAS control module.</li> <li>• SAS control module malfunction.</li> </ul> <p><b>Vehicles without side air bag</b></p> <ul style="list-style-type: none"> <li>• Malfunction of connector between SAS control module and ground.</li> <li>• Open or short circuit in wiring harness between SAS control module and ground.</li> <li>• SAS control module malfunction.</li> </ul>

# ON-BOARD DIAGNOSTIC

PASSENGER-SIDE SIDE AIR BAG MODULE CONNECTOR

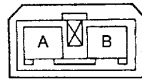

HARNESS SIDE CONNECTOR  
(VIEW FROM TERMINAL SIDE)

SAS CONTROL MODULE CONNECTOR

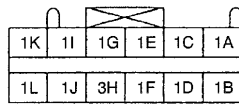

HARNESS SIDE CONNECTOR  
(VIEW FROM HARNESS SIDE)

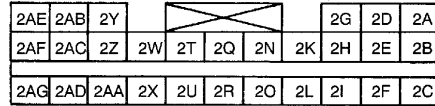

## Diagnostic procedure

STEP	INSPECTION	ACTION
1	<ul style="list-style-type: none"> <li>Is vehicle equipped with side air bag?</li> </ul>	Yes: Go to next step. No: Go to Step 5.
2	<p><b>INSPECT SEPARATOR* OF PASSENGER-SIDE SIDE AIR BAG MODULE CONNECTOR</b></p> <p><b>Warning</b></p> <ul style="list-style-type: none"> <li>Handling air bag system components improperly can accidentally deploy air bag modules and pre-tensioner seat belts, which may seriously injure you. Read AIR BAG SYSTEM SERVICE WARNINGS before handling air bag system components. (See 08-10-3 AIR BAG SYSTEM SERVICE WARNINGS)</li> </ul> <ul style="list-style-type: none"> <li>Turn ignition switch to LOCK position.</li> <li>Disconnect negative battery cable and wait for <b>more than 1 minute</b>.</li> <li>Disconnect passenger-side side air bag module connector.</li> <li>Is separator* of passenger-side side air bag module connector okay?</li> </ul>	Yes: <b>Present malfunction diagnosis:</b> <ul style="list-style-type: none"> <li>Go to next step.</li> </ul> <b>Past malfunction diagnosis:</b> <ul style="list-style-type: none"> <li>Go to Step 3.</li> </ul> No: Replace wiring harness.
3	<p><b>VERIFY WHETHER MALFUNCTION IS IN PASSENGER-SIDE SIDE AIR BAG MODULE OR OTHER PARTS</b></p> <ul style="list-style-type: none"> <li>Connect leads of <b>SST</b> (Fuel And Thermometer checker) or apply <b>2 ohms</b> resistor to passenger-side side air bag module connector terminals A and B.</li> <li>Set resistance of <b>SST</b> (Fuel And Thermometer checker) to <b>2 ohms</b>.</li> <li>Connect negative battery cable.</li> <li>Turn ignition switch to ON position.</li> <li>Is DTC 37 indicated?</li> </ul>	Yes: Go to next step. No: Replace passenger-side side air bag module. (See 08-10-7 SIDE AIR BAG MODULE REMOVAL/INSTALLATION)

08-02

## ON-BOARD DIAGNOSTIC

STEP	INSPECTION	ACTION
4	<p><b>INSPECT WIRING HARNESS BETWEEN PASSENGER-SIDE SIDE AIR BAG MODULE AND SAS CONTROL MODULE</b></p> <ul style="list-style-type: none"> <li>• Turn ignition switch to LOCK position.</li> <li>• Disconnect negative battery cable and wait for <b>more than 1 minute</b>.</li> <li>• Remove column cover.</li> <li>• Disconnect clock spring connector.</li> <li>• Remove glove compartment.</li> <li>• Disconnect passenger-side air bag module connector.</li> <li>• Disconnect driver-side side air bag module connector.</li> <li>• Remove B-pillar lower trims.</li> <li>• Disconnect driver-and passenger-side pre-tensioner seat belt connectors.</li> <li>• Remove left side side wall.</li> <li>• Disconnect all SAS control module connectors.</li> <li>• Inspect following wiring harness between SAS control module connector and passenger-side side air bag module connector terminals (harness side) for short to ground, short to power supply, and open circuit: <ul style="list-style-type: none"> <li>— 1I and A</li> <li>— 1K and B</li> </ul> </li> <li>• Are wiring harnesses okay?</li> </ul>	<p>Yes <b>Present malfunction diagnosis:</b></p> <ul style="list-style-type: none"> <li>• Remove SAS control module. (See 08–10–12 SAS CONTROL MODULE REMOVAL/INSTALLATION)</li> </ul> <p><b>Past malfunction diagnosis:</b></p> <ul style="list-style-type: none"> <li>• Replace passenger-side side air bag module. (See 08–10–7 SIDE AIR BAG MODULE REMOVAL/INSTALLATION)</li> </ul> <p>No Replace wiring harness.</p>
5	<p><b>VERIFY THAT SAS CONTROL MODULE CONNECTOR TERMINAL 2AA IS GROUNDED</b></p> <p><b>Warning</b></p> <ul style="list-style-type: none"> <li>• <b>Handling air bag system components improperly can accidentally deploy air bag modules and pre-tensioner seat belts, which may seriously injure you. Read AIR BAG SYSTEM SERVICE WARNINGS before handling air bag system components. (See 08–10–3 AIR BAG SYSTEM SERVICE WARNINGS)</b></li> </ul> <ul style="list-style-type: none"> <li>• Turn ignition switch to LOCK position.</li> <li>• Disconnect negative battery cable and wait for <b>more than 1 minute</b>.</li> <li>• Remove column cover.</li> <li>• Disconnect clock spring connector.</li> <li>• Remove glove compartment.</li> <li>• Disconnect passenger-side air bag module connector.</li> <li>• Remove B-pillar lower trims.</li> <li>• Disconnect driver-and passenger-side pre-tensioner seat belt connectors.</li> <li>• Remove left side side wall.</li> <li>• Disconnect all SAS control module connectors.</li> <li>• Disconnect driver-side side air bag sensor connector.</li> <li>• Inspect wiring harness between terminal 2AA of SAS control module connector and ground for following. <ul style="list-style-type: none"> <li>— Short to power supply</li> <li>— Open circuit</li> </ul> </li> <li>• Is wiring harnesses okay?</li> </ul>	<p>Yes <b>Present malfunction diagnosis:</b></p> <ul style="list-style-type: none"> <li>• Replace SAS control module. (See 08–10–12 SAS CONTROL MODULE REMOVAL/INSTALLATION)</li> </ul> <p><b>Past malfunction diagnosis:</b></p> <ul style="list-style-type: none"> <li>• Complete inspection by DTC.</li> </ul> <p>No Replace wiring harness.</p>

\* : Consists of the 2 parts of the female connector that separate the short bar from the terminal when connected to the male connector.



# ON-BOARD DIAGNOSTIC

DTC 91

A3U080201046W17

<b>DTC 91</b>	<b>Air bag system warning light system</b>
<b>DETECTION CONDITION</b>	<p><b>Warning</b></p> <ul style="list-style-type: none"> <li>• <b>Detection conditions are for understanding DTC outline before performing inspection. Performing inspection with only detection conditions may cause injury due to operating error or damage the system. When performing inspection, always follow diagnostic procedure.</b></li> </ul> <ul style="list-style-type: none"> <li>• Malfunction in air bag system warning light circuit.</li> </ul>
<b>POSSIBLE CAUSE</b>	<ul style="list-style-type: none"> <li>• Air bag system warning light bulb malfunction.</li> <li>• METER 10 A fuse malfunction.</li> <li>• Instrument cluster malfunction.</li> <li>• Malfunction of connectors between instrument cluster and SAS control module.</li> <li>• Open or short circuit in wiring harness between METER 10 A fuse and instrument cluster.</li> <li>• Open or short circuit in wiring harness between instrument cluster and SAS control module.</li> <li>• SAS control module malfunction.</li> </ul>

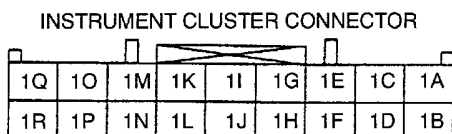

HARNESS SIDE CONNECTOR  
(VIEW FROM HARNESS SIDE)

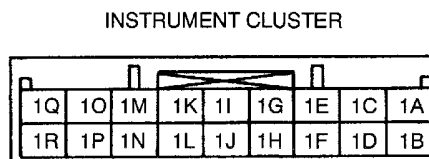

COMPONENT SIDE CONNECTOR  
(VIEW FROM TERMINAL SIDE)

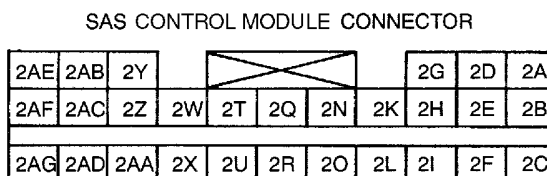

HARNESS SIDE CONNECTOR  
(VIEW FROM HARNESS SIDE)

08-02

**Diagnostic procedure**

STEP	INSPECTION	Yes	ACTION
1	<ul style="list-style-type: none"> <li>• Is this present malfunction diagnosis?</li> </ul>	Yes	Replace SAS control module. (See 08-10-12 SAS CONTROL MODULE REMOVAL/INSTALLATION)
		No	Go to next step.
2	<p><b>INSPECT METER 10 A FUSE</b></p> <ul style="list-style-type: none"> <li>• Turn ignition switch to LOCK position.</li> <li>• Disconnect negative battery cable.</li> <li>• Remove METER 10 A fuse.</li> <li>• Is fuse okay?</li> </ul>	Yes	Reinstall METER 10 A fuse, then go to next step.
		No	Replace METER 10 A fuse.
3	<p><b>INSPECT AIR BAG SYSTEM WARNING LIGHT BULB</b></p> <ul style="list-style-type: none"> <li>• Remove instrument cluster. (See 09-22-3 INSTRUMENT CLUSTER REMOVAL/INSTALLATION)</li> <li>• Remove air bag system warning light bulb.</li> <li>• Is bulb okay?</li> </ul>	Yes	Reinstall air bag system warning light bulb, then go to next step.
		No	Replace air bag system warning light bulb.
4	<p><b>INSPECT INSTRUMENT CLUSTER</b></p> <ul style="list-style-type: none"> <li>• Is there continuity between instrument cluster terminals 1J and 1R?</li> </ul>	Yes	Go to next step.
		No	<p><b>With tachometer</b></p> <ul style="list-style-type: none"> <li>• Replace speedometer and tachometer.</li> </ul> <p><b>Without tachometer</b></p> <ul style="list-style-type: none"> <li>• Replace speedometer. (See 09-22-3 INSTRUMENT CLUSTER DISASSEMBLY/ASSEMBLY)</li> </ul>

## ON-BOARD DIAGNOSTIC

STEP	INSPECTION	ACTION	
5	<b>INSPECT FOR CONTINUITY BETWEEN METER 10 A FUSE AND INSTRUMENT CLUSTER</b> <ul style="list-style-type: none"> <li>• Connect negative battery cable.</li> <li>• Turn ignition switch to ON position.</li> <li>• Measure voltage at instrument cluster connector terminal 1J.</li> <li>• Is voltage <b>more than 9 V</b>?</li> </ul>	Yes	Go to next step.
		No	Replace wiring harness.
6	<b>INSPECT WIRING HARNESS BETWEEN INSTRUMENT CLUSTER AND SAS CONTROL MODULE</b> <p><b>Warning</b></p> <ul style="list-style-type: none"> <li>• <b>Handling air bag system components improperly can accidentally deploy air bag modules and pre-tensioner seat belts, which may seriously injure you. Read AIR BAG SYSTEM SERVICE WARNINGS before handling air bag system components. (See 08–10–3 AIR BAG SYSTEM SERVICE WARNINGS)</b></li> </ul> <ul style="list-style-type: none"> <li>• Turn ignition switch to LOCK position.</li> <li>• Disconnect negative battery cable and wait for <b>more than 1 minute</b>.</li> <li>• Remove column cover.</li> <li>• Disconnect clock spring connector.</li> <li>• Remove glove compartment.</li> <li>• Disconnect passenger-side air bag module connector.</li> <li>• Disconnect driver- and passenger-side side air bag module connectors. (Vehicles with side air bag)</li> <li>• Remove B-pillar trims.</li> <li>• Disconnect driver- and passenger-side pre-tensioner seat belt connectors.</li> <li>• Remove left side side wall.</li> <li>• Disconnect all SAS control module connectors.</li> <li>• Inspect wiring harness between instrument cluster connector terminal 1R and SAS control module connector terminal 2W for following. <ul style="list-style-type: none"> <li>— Short to ground</li> <li>— Short to power supply</li> <li>— Open circuit</li> </ul> </li> <li>• Is wiring harness okay?</li> </ul>	Yes	Go to next step.
		No	Replace wiring harness.
7	<b>INSPECT WIRING HARNESS BETWEEN DLC AND SAS CONTROL MODULE</b> <ul style="list-style-type: none"> <li>• Inspect wiring harness between FAB terminal of DLC and terminal 2W of SAS control module connector for following. <ul style="list-style-type: none"> <li>— Short to ground</li> <li>— Short to power supply</li> </ul> </li> <li>• Is wiring harness okay?</li> </ul>	Yes	Complete inspection by DTC.
		No	Replace wiring harness.

# 08-03 SYMPTOM TROUBLESHOOTING

**AIR BAG SYSTEM WIRING DIAGRAM . 08-03-1**  
**FOREWORD . . . . . 08-03-2**  
 Flowchart . . . . . 08-03-2  
**TRUBLESHOOTING INDEX. . . . . 08-03-4**  
**NO.1 AIR BAG SYSTEM WARNING**  
**LIGHT DOES NOT ILLUMINATE**  
**WHEN IGNITION SWITCH IS**  
**TURNED TO ON POSITION . . . . . 08-03-4**

**NO.2 AIR BAG SYSTEM WARNING LIGHT**  
**ILLUMINATES IMMEDIATELY AFTER IGNITION**  
**SWITCH IS TURNED TO ON POSITION AND**  
**REMAINS ILLUMINATED . . . . . 08-03-6**

## AIR BAG SYSTEM WIRING DIAGRAM

A3U080301046W01

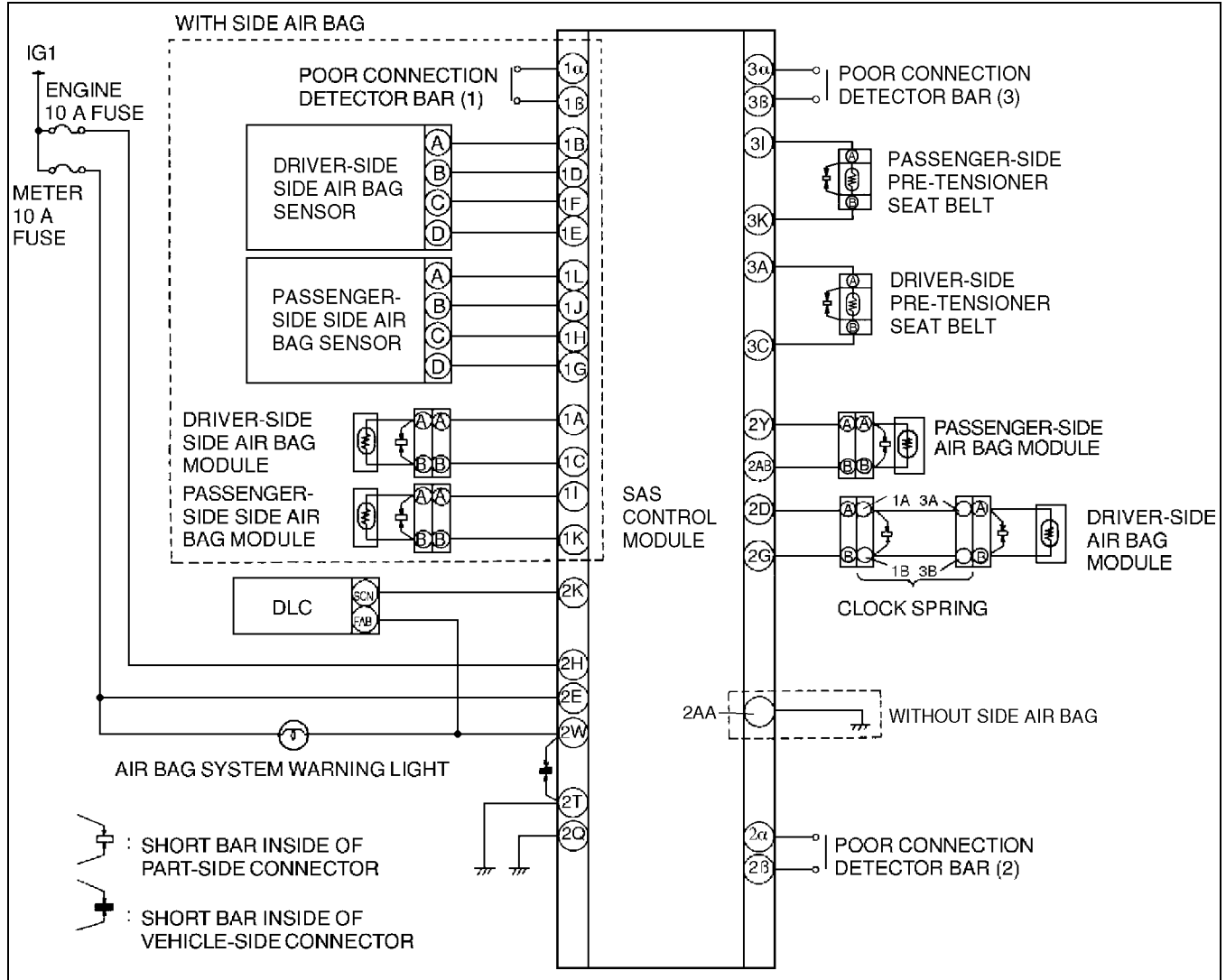

08-03

Z3U0802W001

# SYMPTOM TROUBLESHOOTING

---

## FOREWORD

A3U080301046W02

- Thoroughly read and understand the basic flow of troubleshooting in order to properly perform the procedures. (See 00–00–5 Troubleshooting Procedure.)
- Use the following flowchart to verify the cause of the trouble.

## Flowchart

### Note

- While performing the inspection of the past malfunction code, the applicable DTCs may be added to memory by removing or disconnecting the related parts. Inspect only the DTCs that were indicated before inspecting.
- When DTCs of present malfunction are no longer output after present and/or past malfunctions have been repaired, be sure to perform past malfunction display cancellation to prevent repair of malfunctions that have already been repaired.

# SYMPTOM TROUBLESHOOTING

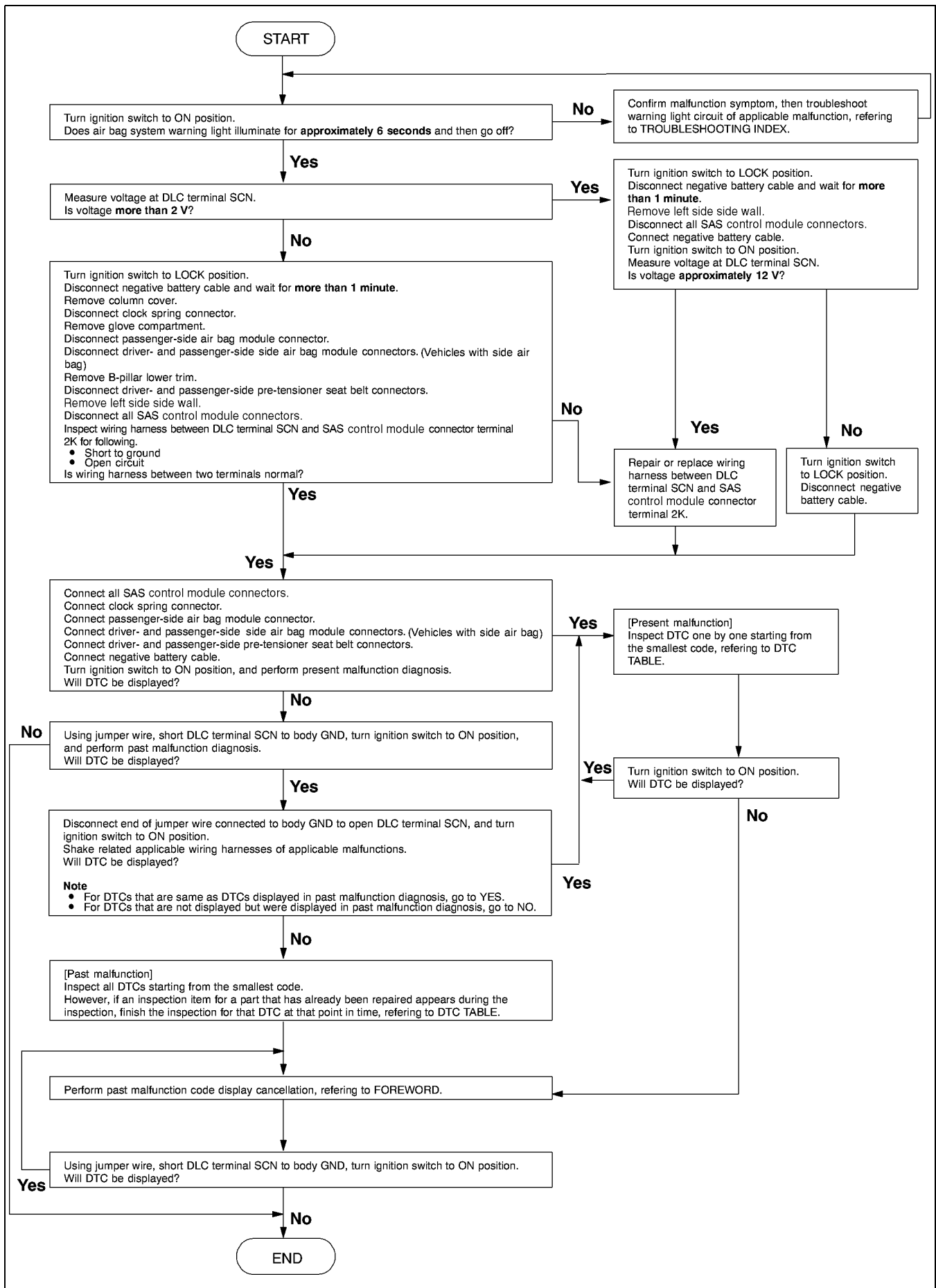

# SYMPTOM TROUBLESHOOTING

## TROUBLESHOOTING INDEX

A3U080301046W03

- Use the chart below to verify the symptoms of the trouble in order to diagnose the appropriate area.

No.	Malfunction symptom	Description	Page
1	Air bag system warning light does not illuminate when ignition switch is turned to ON position.	Malfunction in air bag system warning circuit (open circuit or short to power supply).	(See 08-03-4 NO.1 AIR BAG SYSTEM WARNING LIGHT DOES NOT ILLUMINATE WHEN IGNITION SWITCH IS TURNED TO ON POSITION)
2	Air bag system warning light illuminates immediately after ignition switch is turned to ON position and remains illuminated.	Malfunction in air bag system warning circuit (short to ground).	(See 08-03-6 NO.2 AIR BAG SYSTEM WARNING LIGHT ILLUMINATES IMMEDIATELY AFTER IGNITION SWITCH IS TURNED TO ON POSITION AND REMAINS ILLUMINATED)

### Note

- The following may be the cause of trouble if the symptom does not go away after the symptom troubleshooting steps are followed.
  - Simultaneous poor contact at short connector terminals B and P between METER 10 A fuse and SAS control module, and between ENGINE 10 A fuse and SAS control module.
  - Simultaneous poor contact at SAS control module connector terminals 2T and 2Q.
  - Simultaneous poor contact at SAS control module connector terminals 2E and 2H.
  - Poor contacts in wiring harness between SAS control module connector terminal 2T and ground, and between SAS control module connector terminal 2Q and ground at the same time.
  - Poor contacts or short circuits in wiring harness between METER 10 A fuse and SAS control module, and between ENGINE 10 A fuse and SAS control module at the same time.

## NO.1 AIR BAG SYSTEM WARNING LIGHT DOES NOT ILLUMINATE WHEN IGNITION SWITCH IS TURNED TO ON POSITION

A3U080301046W04

1	<b>Air bag system warning light does not illuminate when ignition switch is turned to ON position.</b>
<p><b>TROUBLESHOOTING HINTS</b></p> <ul style="list-style-type: none"> <li>• Malfunction in air bag system warning light circuit                             <ul style="list-style-type: none"> <li>— Instrument cluster (print plate) malfunction</li> <li>— Air bag system warning light bulb malfunction</li> <li>— Poor contact in instrument cluster connector</li> <li>— Open or short circuit in wiring harness between instrument cluster and SAS control module</li> <li>— SAS control module malfunction</li> </ul> </li> </ul> <p><b>Note</b></p> <ul style="list-style-type: none"> <li>• When inserting insulator between SAS control module connector terminals and short bar, insert it as shown in the figure.</li> </ul>	

- When performing an asterisked(\*) troubleshooting inspection, shake the wiring harness and connectors while doing the inspection to discover the poor contact points which may be the cause of intermittent malfunctions.
- If there is a problem, check to make sure connectors, terminals and wiring harness are connected correctly and undamaged.

## SYMPTOM TROUBLESHOOTING

### Diagnostic procedure

STEP	INSPECTION	ACTION	
1	<b>INSPECT OTHER WARNING AND INDICATOR LIGHTS CIRCUIT IN INSTRUMENT CLUSTER</b> <ul style="list-style-type: none"> <li>• Turn ignition switch to ON position.</li> <li>• Do other warning and indicator lights illuminate?</li> </ul>	Yes	Turn ignition switch to LOCK position, then go to next step.
		No	Inspect instrument cluster power supply system and ground system, then go to Step 6.
2	<b>INSPECT AIR BAG SYSTEM WARNING LIGHT BULB</b> <ul style="list-style-type: none"> <li>• Disconnect negative battery cable.</li> <li>• Remove instrument cluster. (See 09-22-3 INSTRUMENT CLUSTER REMOVAL/INSTALLATION)</li> <li>• Is air bag system warning light bulb functional?</li> </ul>	Yes	Reinstall it properly, then go to next step.
		No	Replace bulb, then go to Step 6.
* 3	<b>INSPECT WIRING HARNESS BETWEEN SAS CONTROL MODULE AND INSTRUMENT CLUSTER FOR CONTINUITY</b> <p><b>Warning</b></p> <ul style="list-style-type: none"> <li>• <b>Handling air bag system components improperly can accidentally deploy air bag modules and pre-tensioner seat belts, which may seriously injure you. Read AIR BAG SYSTEM SERVICE WARNINGS before handling air bag system components. (See 08-10-3 AIR BAG SYSTEM SERVICE WARNINGS)</b></li> </ul> <ul style="list-style-type: none"> <li>• Remove column cover.</li> <li>• Disconnect clock spring connector.</li> <li>• Remove glove compartment.</li> <li>• Disconnect passenger-side air bag module connector.</li> <li>• Disconnect driver- and passenger-side side air bag module connectors. (Vehicles with side air bag)</li> <li>• Remove B-pillar trims.</li> <li>• Disconnect driver- and passenger-side pre-tensioner seat belt connectors.</li> <li>• Remove left side side wall.</li> <li>• Disconnect all SAS control module connectors.</li> <li>• Is there continuity between SAS control module connector terminal 2W and instrument cluster connector terminal 1R?</li> </ul>	Yes	Go to next step.
		No	Replace wiring harness, then go to Step 6.
* 4	<b>INSPECT WIRING HARNESS BETWEEN SAS CONTROL MODULE AND INSTRUMENT CLUSTER FOR SHORT TO POWER SUPPLY</b> <ul style="list-style-type: none"> <li>• Connect negative battery cable.</li> </ul> <p><b>Caution</b></p> <ul style="list-style-type: none"> <li>• <b>Be sure not to cause damage to short bar when inserting insulator. If short bar is damaged, you may not be able to properly inspect connection of SAS control module connector.</b></li> </ul> <ul style="list-style-type: none"> <li>• Insert insulator between SAS control module connector terminals 2W and 2T so short bar cannot function.</li> <li>• Turn ignition switch to ON position.</li> <li>• Measure voltage at instrument cluster connector terminal 1R.</li> <li>• Is voltage <b>more than approximately 9 V</b>?</li> </ul>	Yes	Replace wiring harness, then go to Step 6.
		No	Go to next step.

08-03

## SYMPTOM TROUBLESHOOTING

STEP	INSPECTION	ACTION
5	<b>VERIFY WHETHER MALFUNCTION IS IN PRINT PLATE IN INSTRUMENT CLUSTER</b> <ul style="list-style-type: none"> <li>Is there continuity between terminals 1J and 1R of print plate on instrument cluster?</li> </ul>	Yes Replace SAS control module, then go to next step. (See 08-10-12 SAS CONTROL MODULE REMOVAL/INSTALLATION)
		No Replace instrument cluster, then go to next step. (See 09-22-3 INSTRUMENT CLUSTER REMOVAL/INSTALLATION)
6	<b>VERIFY WHETHER MALFUNCTION SYMPTOM OCCURS AFTER REPAIR OR NOT</b> <ul style="list-style-type: none"> <li>Connect all SAS control module connectors.</li> <li>Connect driver- and passenger-side pretensioner seat belt connectors.</li> <li>Connect driver- and passenger-side side air bag module connectors. (Vehicles with side air bag)</li> <li>Connect passenger-side air bag module connector.</li> <li>Connect clock spring connector.</li> <li>Connect instrument cluster connector.</li> <li>Connect negative battery cable.</li> <li>Turn ignition switch to ON position.</li> <li>Does air bag system warning light operate properly?</li> </ul>	Yes Complete troubleshooting, then explain repairs to customer.
		No Recheck malfunction symptoms, then repeat from Step 1 if malfunction recurs.

### NO.2 AIR BAG SYSTEM WARNING LIGHT ILLUMINATES IMMEDIATELY AFTER IGNITION SWITCH IS TURNED TO ON POSITION AND REMAINS ILLUMINATED

A3U080301046W05

2	<b>Air bag system warning light illuminates immediately after ignition switch is turned to ON position and remains illuminated.</b>
<b>TROUBLESHOOTING HINTS</b> <ul style="list-style-type: none"> <li>Malfunction in air bag system warning light circuit                             <ul style="list-style-type: none"> <li>Instrument cluster (print plate) malfunction</li> <li>Malfunction of short bar between SAS control module connector terminals 2W and 2T</li> <li>No connection in SAS control module connector</li> <li>Short circuit in wiring harness between instrument cluster and SAS control module</li> <li>SAS control module malfunction</li> </ul> </li> </ul> <p><b>Note</b></p> <ul style="list-style-type: none"> <li>When inserting insulator between SAS control module connector terminals and short bar, insert it as shown in the figure.</li> </ul>	

- When performing an asterisked(\*) troubleshooting inspection, shake the wiring harness and connectors while doing the inspection to discover the poor contact points which may be the cause of intermittent malfunctions.
- If there is a problem, check to make sure connectors, terminals and wiring harness are connected correctly and undamaged.



## SYMPTOM TROUBLESHOOTING

### Diagnostic procedure

STEP	INSPECTION	ACTION
1	<b>VERIFY THAT SAS CONTROL MODULE CONNECTOR IS CONNECTED</b>  <b>Warning</b> <ul style="list-style-type: none"> <li>• Handling air bag system components improperly can accidentally deploy air bag modules and pre-tensioner seat belts, which may seriously injure you. Read AIR BAG SYSTEM SERVICE WARNINGS before handling air bag system components. (See 08-10-3 AIR BAG SYSTEM SERVICE WARNINGS)</li> </ul> <ul style="list-style-type: none"> <li>• Turn ignition switch to LOCK position.</li> <li>• Disconnect negative battery cable and wait for <b>more than 1 minute</b>.</li> <li>• Remove left side side wall.</li> <li>• Are all SAS control module connectors securely connected?</li> </ul>	Yes Go to next step.
		No Reconnect connector properly, then go to Step 6.
2	<b>INSPECT SAS CONTROL MODULE TERMINALS 2W AND 2T</b> <ul style="list-style-type: none"> <li>• Remove column cover.</li> <li>• Disconnect clock spring connector.</li> <li>• Remove glove compartment.</li> <li>• Disconnect passenger-side air bag module connector.</li> <li>• Disconnect driver- and passenger-side side air bag module connectors. (Vehicles with side air bag)</li> <li>• Remove B-pillar trims.</li> <li>• Disconnect driver- and passenger-side pre-tensioner seat belt connectors.</li> <li>• Disconnect all SAS control module connectors.</li> <li>• Is short bar between SAS control module connector terminals 2W and 2T bent?</li> </ul>	Yes Replace wiring harness, then go to Step 6.
		No Go to next step.
3	<b>INSPECT SHORT BAR HOOK OF SAS CONTROL MODULE</b> <ul style="list-style-type: none"> <li>• Is short bar hook of SAS control module okay?</li> </ul>	Yes Go to next step.
		No Replace SAS control module, then go to Step 6. (See 08-10-12 SAS CONTROL MODULE REMOVAL/INSTALLATION)
* 4	<b>INSPECT WIRING HARNESS BETWEEN SAS CONTROL MODULE AND INSTRUMENT CLUSTER FOR SHORT TO GROUND</b> <ul style="list-style-type: none"> <li>• Remove instrument cluster. (See 09-22-3 INSTRUMENT CLUSTER REMOVAL/INSTALLATION)</li> </ul> <b>Caution</b> <ul style="list-style-type: none"> <li>• Be sure not to cause damage to short bar when inserting insulator. If short bar is damaged, you may not be able to properly inspect connection of SAS control module connector.</li> </ul> <ul style="list-style-type: none"> <li>• Insert insulator between SAS control module connector terminals 2W and 2T so short bar cannot function.</li> <li>• Is there continuity between SAS (control module) connector terminal 2W and ground?</li> </ul>	Yes Replace wiring harness, then go to Step 6.
		No Go to next step.
5	<b>INSPECT FOR SHORT TO GROUND IN INSTRUMENT CLUSTER CIRCUIT</b> <ul style="list-style-type: none"> <li>• Is there continuity between terminal 1R and any of following terminals of print plate on instrument cluster? <ul style="list-style-type: none"> <li>— Terminal 1D</li> <li>— Terminal 1A</li> <li>— Terminal 2B (Without ABS or ABS/TCS)</li> </ul> </li> </ul>	Yes Replace instrument cluster, then go to next step. (See 09-22-3 INSTRUMENT CLUSTER REMOVAL/INSTALLATION)
		No Replace SAS control module, then go to next step. (See 08-10-12 SAS CONTROL MODULE REMOVAL/INSTALLATION)

08-03

## SYMPTOM TROUBLESHOOTING

STEP	INSPECTION	ACTION				
6	<p><b>VERIFY WHETHER MALFUNCTION SYMPTOM OCCURS AFTER REPAIR OR NOT</b></p> <ul style="list-style-type: none"> <li>• Connect all SAS control module connectors.</li> <li>• Connect driver- and passenger-side pretensioner seat belt connectors.</li> <li>• Connect driver- and passenger-side side air bag module connectors. (Vehicles with side air bag)</li> <li>• Connect passenger-side air bag module connector.</li> <li>• Connect clock spring connector.</li> <li>• Connect instrument cluster connector.</li> <li>• Connect negative battery cable.</li> <li>• Turn ignition switch to ON position.</li> <li>• Does air bag system warning light operate properly?</li> </ul>	<table border="1" style="width: 100%; border-collapse: collapse;"> <tr> <td style="text-align: center; width: 50px;">Yes</td> <td>Complete troubleshooting, then explain repairs to customer.</td> </tr> <tr> <td style="text-align: center;">No</td> <td>Recheck malfunction symptoms, then repeat from Step 1 if malfunction recurs.</td> </tr> </table>	Yes	Complete troubleshooting, then explain repairs to customer.	No	Recheck malfunction symptoms, then repeat from Step 1 if malfunction recurs.
Yes	Complete troubleshooting, then explain repairs to customer.					
No	Recheck malfunction symptoms, then repeat from Step 1 if malfunction recurs.					

## **08-10 AIR BAG SYSTEM**

<b>LOCATION INDEX</b> .....	<b>08-10-2</b>
<b>AIR BAG SYSTEM SERVICE</b>	
<b>WARNINGS</b> .....	<b>08-10-3</b>
Component Disassembly .....	<b>08-10-3</b>
Wiring Harness Repair .....	<b>08-10-3</b>
Air Bag Module Inspection .....	<b>08-10-3</b>
Air Bag Module Handling .....	<b>08-10-3</b>
Side Air Bag Module Handling .....	<b>08-10-4</b>
SAS Control Module Handling .....	<b>08-10-4</b>
Side Air Bag Sensor Handling .....	<b>08-10-4</b>
Pre-tensioner Seat Belt Inspection ...	<b>08-10-5</b>
Component Handling .....	<b>08-10-5</b>
Component Reuse .....	<b>08-10-5</b>
<b>DRIVER-SIDE AIR BAG MODULE</b>	
<b>REMOVAL/INSTALLATION</b> .....	<b>08-10-5</b>
Connector Installation Note .....	<b>08-10-6</b>
<b>PASSENGER-SIDE AIR BAG MODULE</b>	
<b>REMOVAL/INSTALLATION</b> .....	<b>08-10-6</b>
Connector Installation Note .....	<b>08-10-6</b>
<b>SIDE AIR BAG MODULE</b>	
<b>REMOVAL/INSTALLATION</b> .....	<b>08-10-7</b>
<b>CLOCK SPRING ADJUSTMENT</b> .....	
<b>08-10-8</b>	
<b>CLOCK SPRING</b>	
<b>REMOVAL/INSTALLATION</b> .....	<b>08-10-9</b>
<b>CLOCK SPRING INSPECTION</b> .....	
<b>08-10-10</b>	
<b>SIDE AIR BAG SENSOR</b>	
<b>REMOVAL/INSTALLATION</b> .....	<b>08-10-10</b>
Connector Removal Note .....	<b>08-10-11</b>
Connector Installation Note .....	<b>08-10-11</b>
<b>SAS CONTROL MODULE</b>	
<b>REMOVAL/INSTALLATION</b> .....	<b>08-10-12</b>
<b>SAS CONTROL MODULE BRACKET</b>	
<b>REMOVAL/INSTALLATION</b> .....	<b>08-10-12</b>
<b>AIR BAG MODULE AND</b>	
<b>PRE-TENSIONER</b>	
<b>SEAT BELT DEPLOYMENT</b>	
<b>AUTHORIZATION PROCEDURES</b> ....	<b>08-10-13</b>
After Replacing SAS Control Module ..	<b>08-10-13</b>
After Replacing Side Air Bag Sensor ..	<b>08-10-13</b>
<b>AIR BAG MODULE AND</b>	
<b>PRE-TENSIONER</b>	
<b>SEAT BELT DEPLOYMENT</b>	
<b>PROCEDURES</b> .....	<b>08-10-13</b>
Deployment Procedure for	
Inside of Vehicle .....	<b>08-10-13</b>
Deployment Procedure for	
Outside of Vehicle .....	<b>08-10-16</b>
<b>AIR BAG MODULE AND</b>	
<b>PRE-TENSIONER</b>	
<b>SEAT BELT DISPOSAL</b>	
<b>PROCEDURES</b> .....	<b>08-10-23</b>
<b>INSPECTION OF SST</b>	
<b>(DEPLOYMENT TOOL)</b> .....	<b>08-10-24</b>
Inspection Procedure .....	<b>08-10-24</b>

# AIR BAG SYSTEM

## LOCATION INDEX

A3U081001046W01

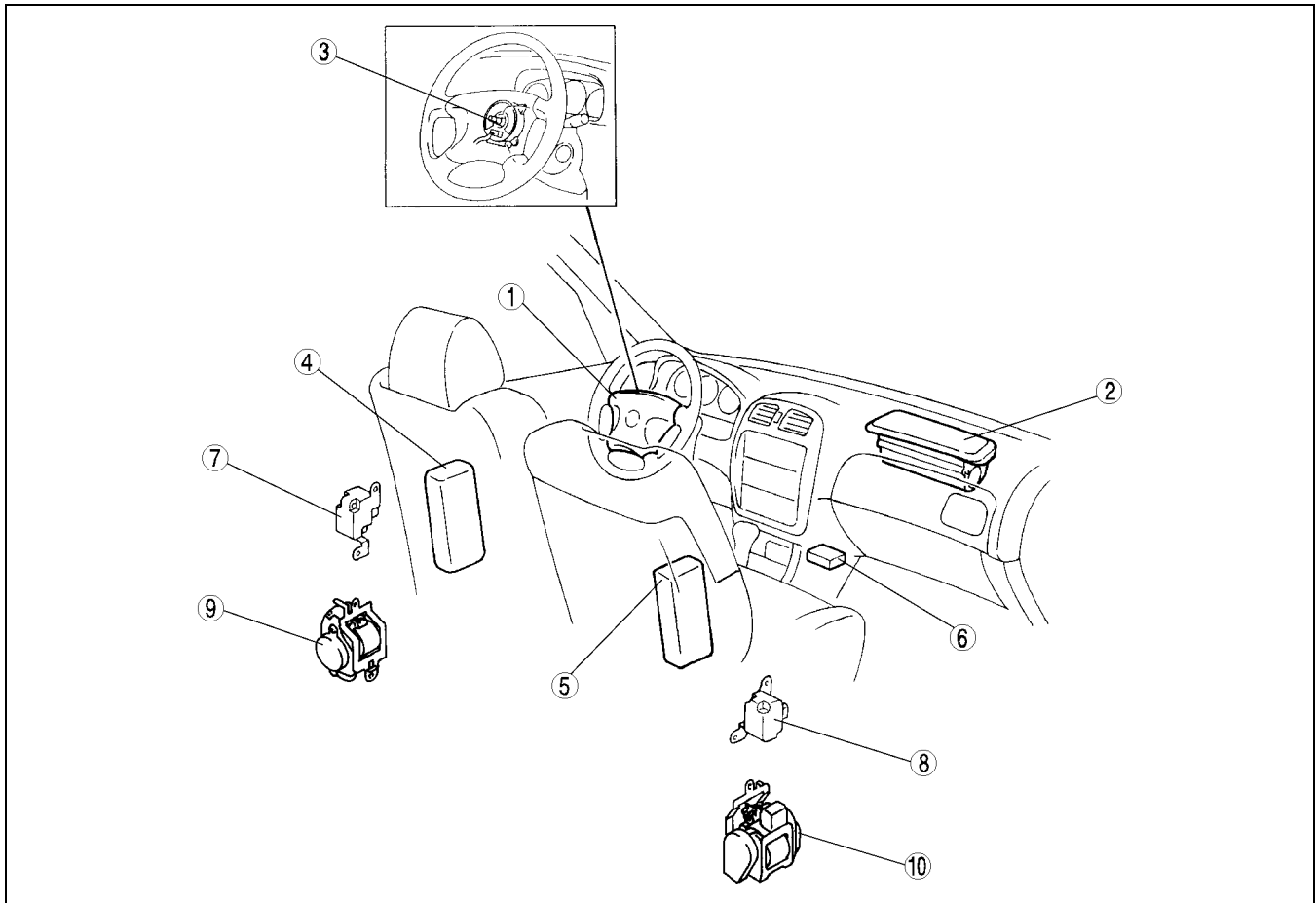

Z3U0810W007

1	Driver-side air bag module (See 08-10-5 DRIVER-SIDE AIR BAG MODULE REMOVAL/INSTALLATION)
2	Passenger-side air bag module (See 08-10-6 PASSENGER-SIDE AIR BAG MODULE REMOVAL/INSTALLATION)
3	Clock spring (See 08-10-8 CLOCK SPRING ADJUSTMENT) (See 08-10-9 CLOCK SPRING REMOVAL/INSTALLATION) (See 08-10-10 CLOCK SPRING INSPECTION)
4	Driver-side side air bag module (See 08-10-7 SIDE AIR BAG MODULE REMOVAL/INSTALLATION)
5	Passenger-side side air bag module (See 08-10-7 SIDE AIR BAG MODULE REMOVAL/INSTALLATION)

6	SAS control module (See 08-10-12 SAS CONTROL MODULE REMOVAL/INSTALLATION) (See 08-10-12 SAS CONTROL MODULE BRACKET REMOVAL/INSTALLATION)
7	Driver-side side air bag sensor (See 08-10-10 SIDE AIR BAG SENSOR REMOVAL/INSTALLATION)
8	Passenger-side side air bag sensor (See 08-10-10 SIDE AIR BAG SENSOR REMOVAL/INSTALLATION)
9	Driver-side pre-tensioner seat belt (See 08-11-1 FRONT SEAT BELT REMOVAL/INSTALLATION)
10	Passenger-side pre-tensioner seat belt (See 08-11-1 FRONT SEAT BELT REMOVAL/INSTALLATION)

# AIR BAG SYSTEM

## AIR BAG SYSTEM SERVICE WARNINGS

A3U081001046W02

### Component Disassembly

- Disassembling and reassembling the components of the air bag system can render the system inoperative, which may result in serious injury or death in the event of an accident. Do not disassemble any air bag system component.

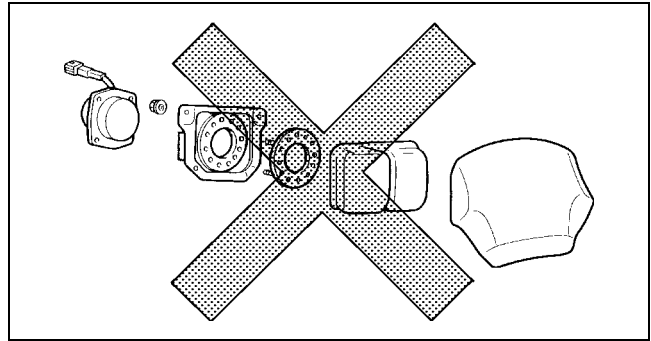

YDE81301200

### Wiring Harness Repair

- Incorrectly repairing an air bag system wiring harness can accidentally deploy the air bag module or pre-tensioner seat belt, which can cause serious injury. If a problem is found in the system wiring, replace the wiring harness. Do not try to repair it.

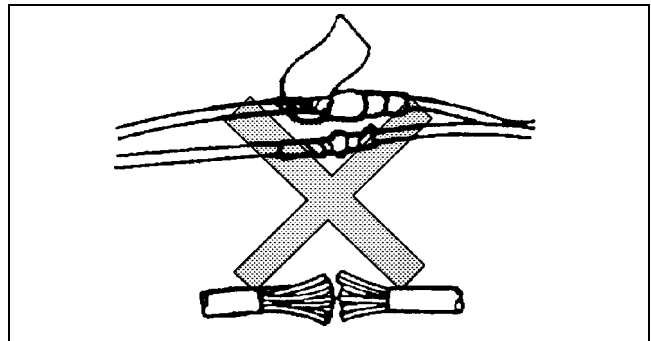

YDE81301201

### Air Bag Module Inspection

- Inspecting an air bag module using an ohmmeter can deploy the air bag module, which may cause serious injury. Do not use an ohmmeter to inspect an air bag module. Always use the on-board diagnostic function to diagnose the air bag module for malfunctions. (See 08-02-2 FOREWORD.)

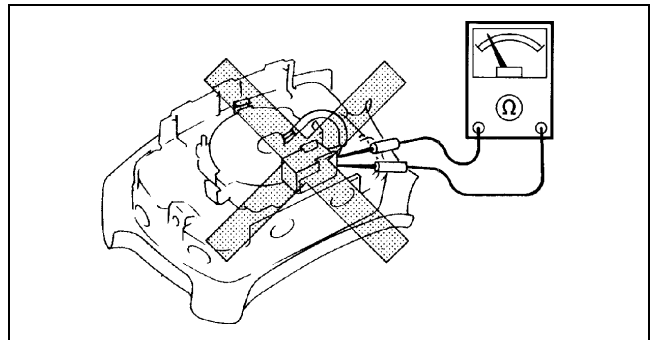

X3U810WA2

### Air Bag Module Handling

- A live (undeployed) air bag module may accidentally deploy when it is handled and cause serious injury. When carrying a live (undeployed) air bag module, point the front surface away from your body to lessen the chance of injury in case it deploys.

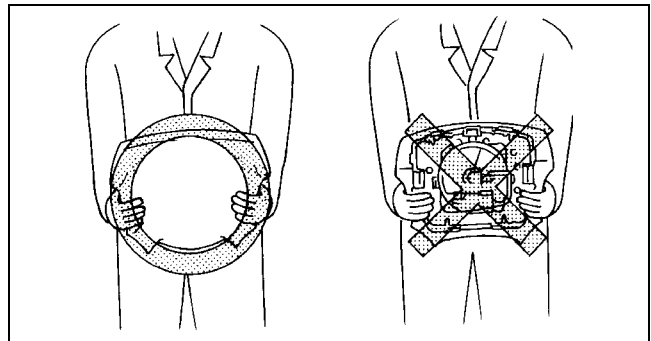

YDE81301004

08-10

## AIR BAG SYSTEM

- A live (undeployed) air bag module placed face down on a surface is dangerous. If the air bag module deploys, the motion of the module can cause serious injury. Always face the front surface up to reduce the motion of the module in case it accidentally deploys.

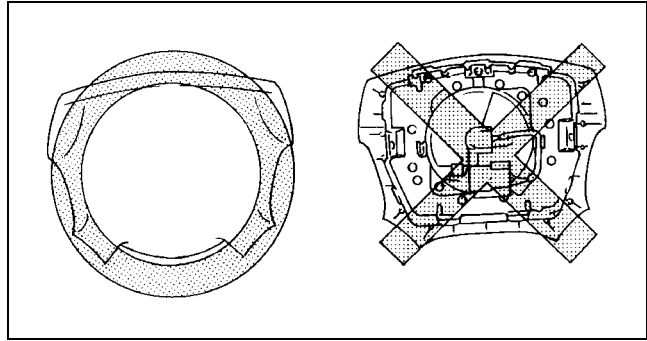

YDE81301005

### Side Air Bag Module Handling

- When the side air bag module deploys due to a collision, the interior of the seat back (pad, frame, etc.) may become damaged. If the seat back is reused and the side air bag module does not deploy properly, a serious accident may result. When the side air bag module deploys, always replace both the side air bag module and the seat back (pad, frame, trim) with new parts. After service, confirm that the seat operates normally and that the harness is positioned properly.

### SAS Control Module Handling

- Disconnecting the SAS control module connector or removing the SAS control module with the ignition switch at ON position can cause the air bag modules to deploy, which may seriously injure you. Before disconnecting the SAS control module connector or removing the SAS control module, turn the ignition switch to LOCK position, then disconnect the negative battery cable and wait for more than 1 minute to allow the backup power supply of the SAS control module to deplete its stored power.
- Connecting the SAS control module connector without firmly installing the SAS control module to the vehicle is dangerous. The crash sensor inside the control module may send an electrical signal to the air bag modules. This will deploy the air bag modules, which may result in serious injury. Therefore, before connecting the connector, firmly mount the control module to the vehicle.
- For vehicles with a single point sensor, once an air bag module is deployed due to an accident or other causes, the SAS control module must be replaced with a new one even if the used one does not have any external signs of damage. The used SAS control module may have been damaged internally which may cause improper operation, resulting in major injuries or even death. The used single point SAS control module cannot be bench-checked or self-checked.

### Side Air Bag Sensor Handling

- Disconnecting the side air bag sensor connector or removing the side air bag sensor with the ignition switch at ON position can cause the side air bag sensor to operate and the side air bag module to deploy, which may seriously injure you. Before disconnecting the side air bag sensor connector or removing the side air bag sensor, always turn the ignition switch to LOCK position, then disconnect the negative battery cable and wait for more than 1 minute to allow the backup power supply of the SAS control module to deplete its stored power.
- If the side air bag sensor is subjected to shock or the sensor is disassembled, the side air bag module may operate (deploy) suddenly and cause injury, or it may fail to operate normally and cause a serious accident. Do not subject the side air bag sensor to shock or disassemble the sensor.
- Because a sensor is built into the side air bag sensor, when the side air bag module operates (deploys), there may be a problem, such as an internal malfunction, even if there is not any external damage or deformation. If the side air bag sensor is reused, the side air bag module may fail to operate normally and cause a serious injury. Always replace the side air bag sensor with a new part. The side air bag sensor cannot be bench-checked or self-checked.

# AIR BAG SYSTEM

## Pre-tensioner Seat Belt Inspection

- Inspecting a pre-tensioner seat belt using an ohmmeter can deploy the pre-tensioner seat belt, which can cause serious injury. Do not use an ohmmeter to inspect the pre-tensioner seat belt. Always use the on-board diagnostic to diagnose the pre-tensioner seat belt for malfunctions.

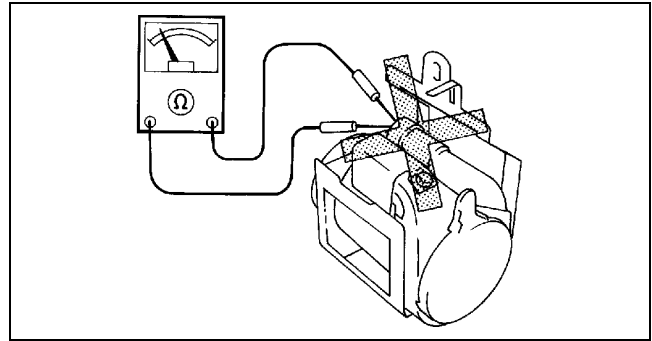

Z3U0810W003

## Component Handling

- Oil, grease, water, etc. on components may cause the air bag modules and pre-tensioner seat belt to fail to deploy in an accident, which may cause serious injury. Do not allow oil, grease, water, etc., on components.
- Inserting a screwdriver, etc. into the connector of an air bag module or a pre-tensioner seat belt may damage the connector and cause the air bag module to deploy improperly, which may cause serious injury. Do not insert any foreign objects into the connector.

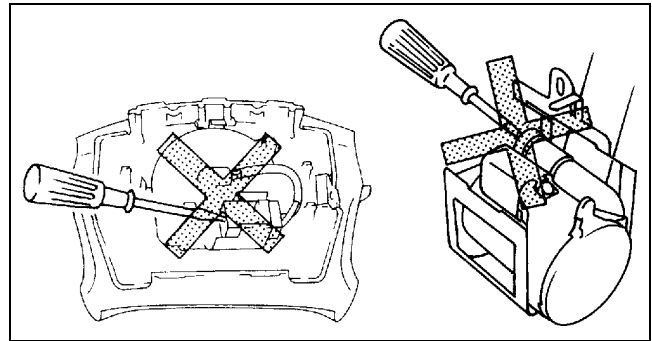

Z3U0810W004

08-10

## Component Reuse

- Even if an air bag module or a pre-tensioner seat belt does not deploy in a collision and does not have any external signs of damage, it may have been damaged internally, which may cause improper operation. Improper operation may cause serious injury. Always self-check the undamaged air bag module or pre-tensioner seat belt to determine whether it can be reused. (See 08-02-2 FOREWORD.)

## DRIVER-SIDE AIR BAG MODULE REMOVAL/INSTALLATION

A3U081057010W01

### Warning

- Handling the air bag module improperly can accidentally deploy the air bag module, which may seriously injure you. Read AIR BAG SYSTEM SERVICE WARNINGS before handling the air bag module. (See 08-10-3 AIR BAG SYSTEM SERVICE WARNINGS.)

- Turn the ignition switch to LOCK position.
- Disconnect the negative battery cable and wait for **more than 1 minute**.
- Remove in the order indicated in the table.

1	Cover
2	Bolt
3	Connector (See 08-10-6 Connector Installation Note)
4	Driver-side air bag module

- Install in the reverse order of removal.
- Turn the ignition switch to ON position.
- Verify that the air bag system warning light illuminates for **approximately 6 seconds** and then goes off.
  - If the air bag system warning light does not operate in the manner described above, there are malfunctions in the system. Inspect the system using the on-board diagnostic function. (See 08-02-2 FOREWORD.)

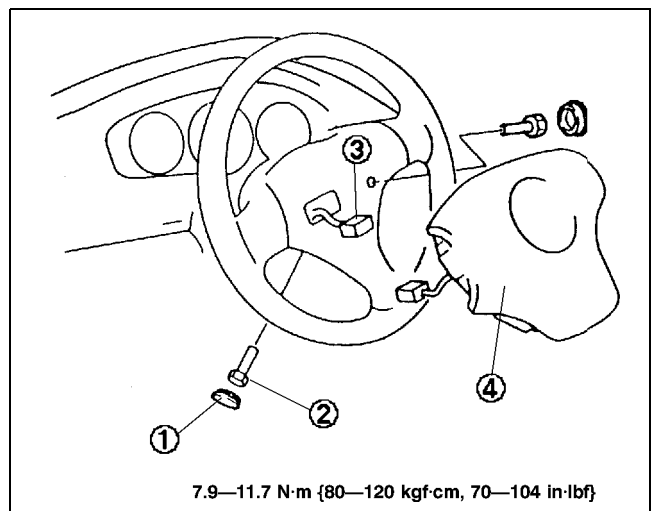

A3U0810W101

# AIR BAG SYSTEM

## Connector Installation Note

1. Install the connector and secure the car-side harness onto the hook as shown in the figure.

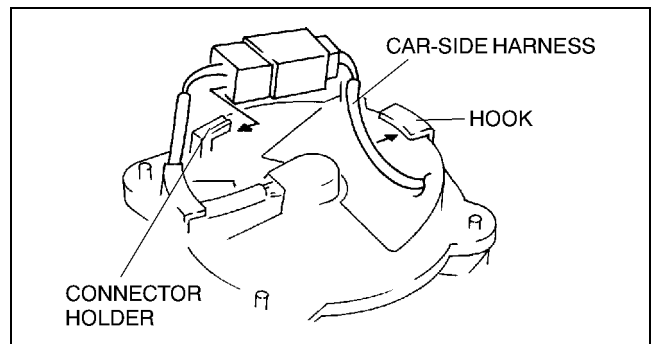

A3U0810W002

## PASSENGER-SIDE AIR BAG MODULE REMOVAL/INSTALLATION

A3U081057050W01

### Warning

- Handling the air bag module improperly can accidentally deploy the air bag module, which may seriously injure you. Read AIR BAG SYSTEM SERVICE WARNINGS before handling the air bag module. (See 08-10-3 AIR BAG SYSTEM SERVICE WARNINGS.)

1. Turn the ignition switch to LOCK position.
2. Disconnect the negative battery cable and wait for **more than 1 minute**.
3. Remove the glove compartment.
4. Remove in the order indicated in the table.

1	Connector (See 08-10-6 Connector Installation Note)
2	Bolt
3	Passenger-side air bag module

5. Install in the reverse order of removal.
6. Turn the ignition switch to ON position.
7. Verify that the air bag system warning light illuminates for **approximately 6 seconds** and then goes off.
  - If the air bag system warning light does not operate in the manner described above, there are malfunctions in the system. Inspect the system using the on-board diagnostic function. (See 08-02-2 FOREWORD.)

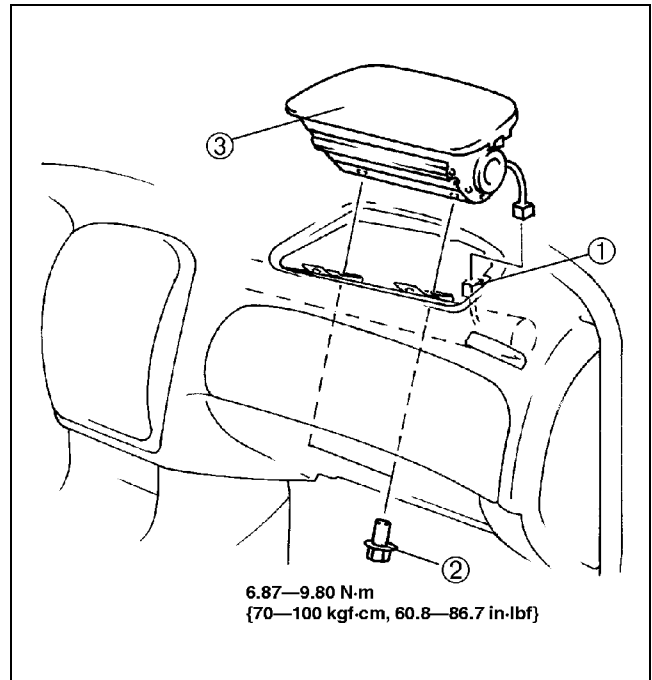

X3U810WAA

## Connector Installation Note

1. Install the connector as shown in the figure.

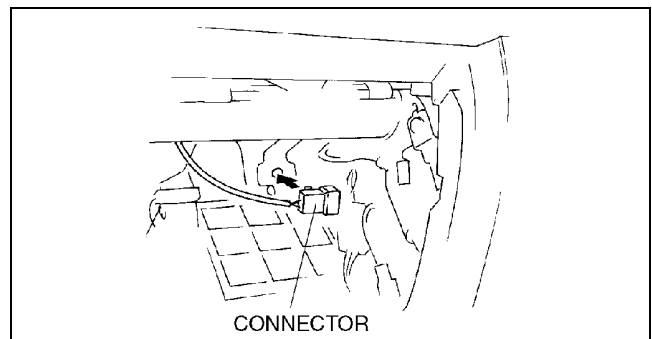

Y3U810WAN



# AIR BAG SYSTEM

## SIDE AIR BAG MODULE REMOVAL/INSTALLATION

A3U081000147W01

### Warning

- Handling the air bag module improperly can accidentally deploy the air bag module, which may seriously injure you. Read AIR BAG SYSTEM SERVICE WARNINGS before handling the air bag module. (See 08-10-3 AIR BAG SYSTEM SERVICE WARNINGS.)

### Warning

- If the side air bag module is installed with a foreign body in the seat back, the debris may be scattered when the side air bag module operates (deploys), causing injury. Verify that there is no foreign body in the seat back before installing the side air bag module.

1. Remove the front seat. (See 09-13-1 FRONT SEAT REMOVAL/INSTALLATION.)
2. Remove the harness clips.

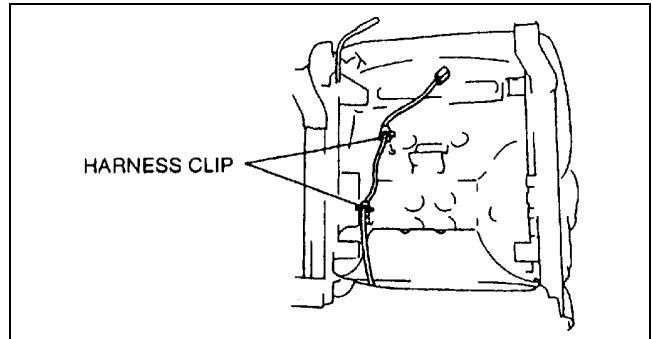

Y3U810WA2

3. Undo the hook on the seat back cushion.

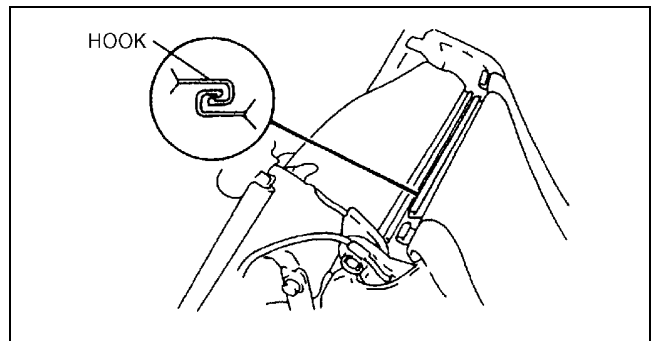

Y3U810WA3

4. Unzip the seat back trim.

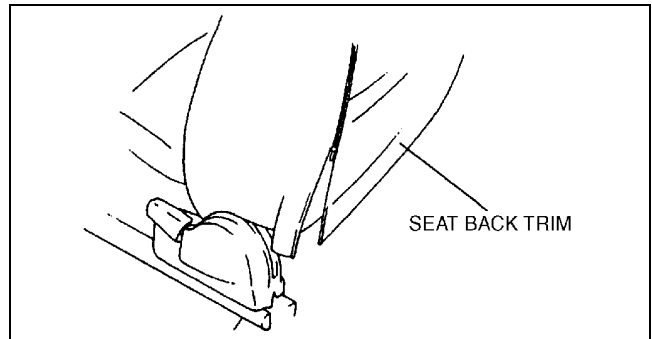

Y3U810WA4

5. Remove the harness belts.

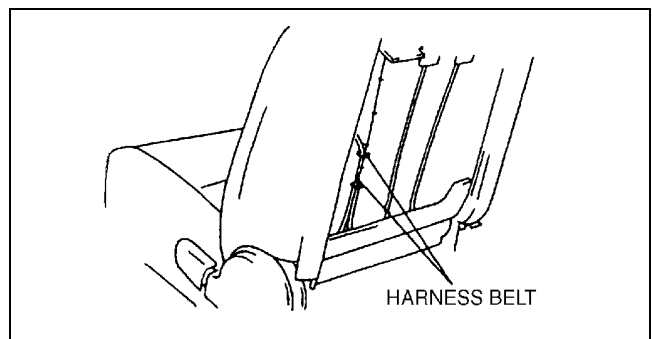

Y3U810WA5

08-10

## AIR BAG SYSTEM

6. Remove the hog rings.
7. Turn over the seat back cushion.

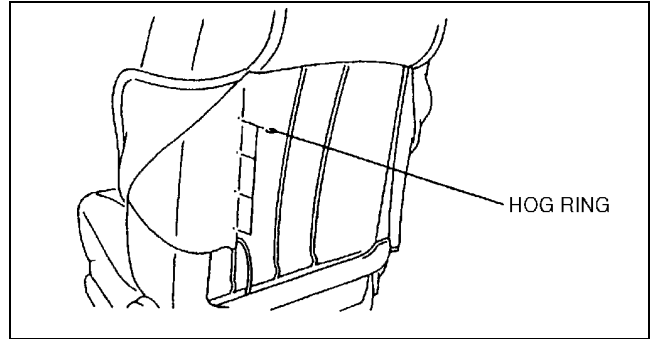

Y3U810WA6

8. Remove the nuts to remove the side air bag module.

### Warning

- If the air bag harness is not secured at the marked point or the harness is caught, the side air bag module may fail to operate (deploy) in an accident, causing a serious accident. Be sure to secure the air bag harness at the marked point, and make sure the harness is not caught during operation of the seat.

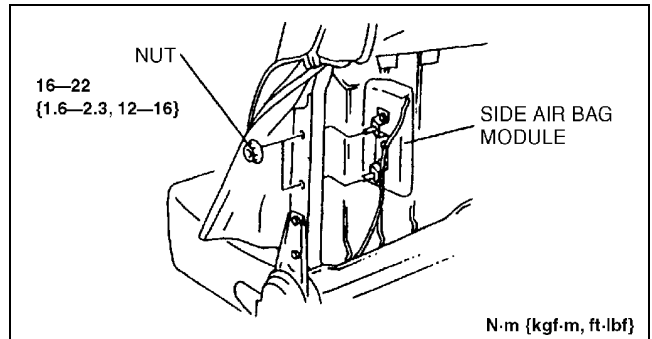

N·m {kgf·m, ft·lbf}

Y3U810WA7

9. Install in the reverse order of removal.
10. Turn the ignition switch to ON position.
11. Verify that the air bag system warning light illuminates for **approximately 6 seconds** and then goes off.
  - If the air bag system warning light does not operate in the manner described above, there are malfunctions in the system. Inspect the system using the on-board diagnostic function. (See 08-02-2 FOREWORD.)

## CLOCK SPRING ADJUSTMENT

A3U081066123W01

### Note

- The adjustment procedure is also specified on the caution label of the clock spring.

1. Set the front wheels straight ahead.

### Caution

- The clock spring will break if over-wound. Do not forcibly turn the clock spring when turning it.

2. Turn the clock spring clockwise until it stops.

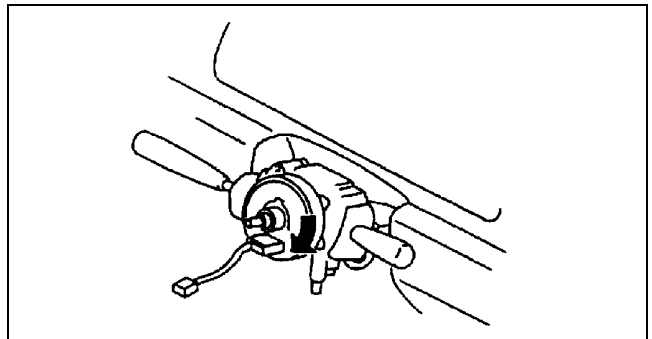

X3U810WAF

# AIR BAG SYSTEM

- Turn the clock spring counterclockwise **2 3/4 turns**.

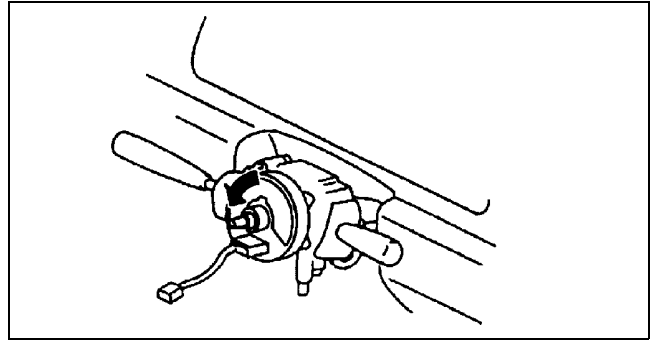

X3U810WAG

- Align the mark on the clock spring with the mark on the outer housing.

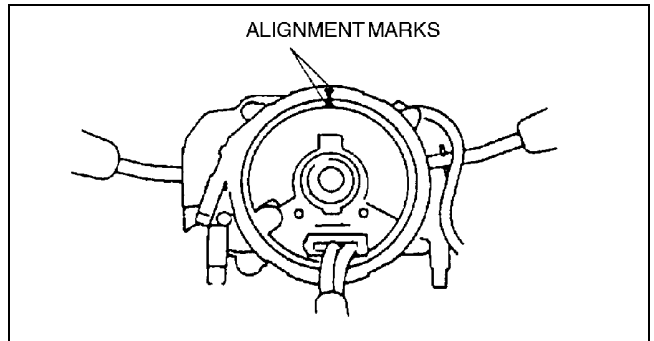

X3U810WAH

## CLOCK SPRING REMOVAL/INSTALLATION

A3U081066123W02

08-10

- Disconnect the negative battery cable.
- Remove the driver-side air bag module. (See 08-10-5 DRIVER-SIDE AIR BAG MODULE REMOVAL/INSTALLATION.)
- Remove the steering wheel. (See 06-12-6 STEERING WHEEL AND COLUMN REMOVAL/INSTALLATION.)
- Remove the column cover.
- Remove in the order indicated in the table.

1	Connector
2	Screw
3	Clock spring

- Install in the reverse order of removal.

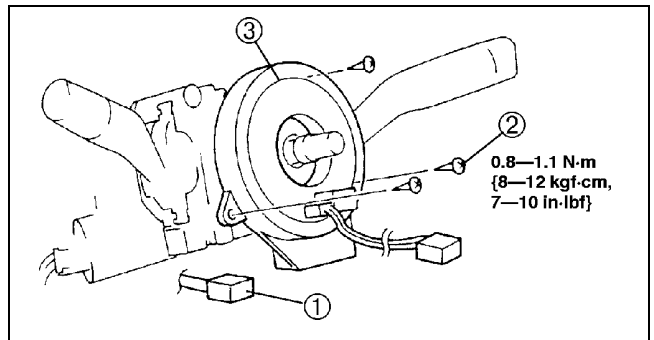

X3U810WAE

# AIR BAG SYSTEM

## CLOCK SPRING INSPECTION

A3U081066123W03

1. Remove the clock spring. (See 08–10–9 CLOCK SPRING REMOVAL/INSTALLATION.)
2. Inspect for continuity between the clock spring terminals using an ohmmeter.
  - If not as specified, replace the clock spring.

○—○ : Continuity

Test condition	Terminal											
	1A	1B	2A	2B	2C	2D	3A	3B	4A	4B	4C	4D
Constant	○	○					○	○				
			○						○			
				○						○		
					○						○	
						○						○

Y3U810WAJ

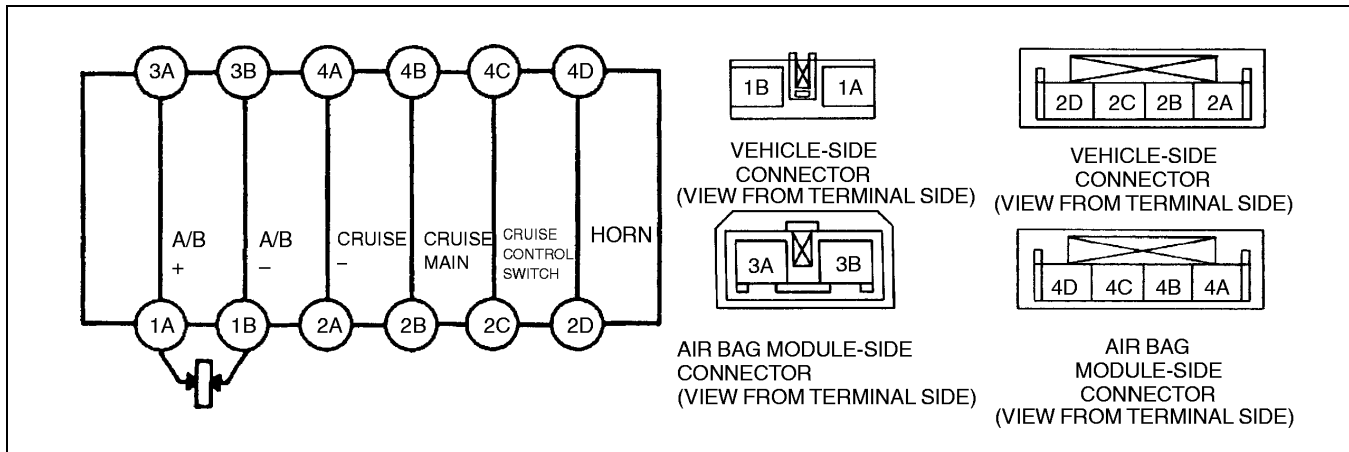

Y3U810WAJ

### Note

- When the vehicle-side connector of clock spring is disconnected, the terminals 1A and 1B are shorted to prevent unexpected deployment of the air bag module. When it is connected, the terminals are open.

## SIDE AIR BAG SENSOR REMOVAL/INSTALLATION

A3U081000146W01

### Warning

- Handling the side air bag sensor improperly can accidentally deploy the side air bag module, which may seriously injure you. Read AIR BAG SYSTEM SERVICE WARNINGS before handling the side air bag sensor. (See 08–10–3 AIR BAG SYSTEM SERVICE WARNINGS.)

1. Turn the ignition switch to LOCK position.
2. Disconnect the negative battery cable and wait for **more than 1 minute**.
3. Remove the B-pillar lower trim. (See 09–17–10 B-PILLAR LOWER TRIM REMOVAL.)
4. Remove in the order indicated in the table.

1	Bolt
2	Connector (See 08–10–11 Connector Removal Note) (See 08–10–11 Connector Installation Note)
3	Side air bag sensor

5. Install in the reverse order of removal.

### Note

- When a new side air bag sensor has been installed, perform the air bag module deployment authorization procedure. (See 08–10–13 AIR BAG MODULE AND PRE-TENSIONER SEAT BELT DEPLOYMENT AUTHORIZATION PROCEDURES.)

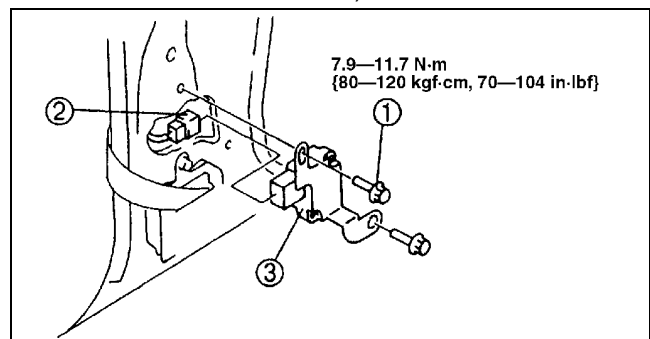

Y3U810WA9

## AIR BAG SYSTEM

6. Turn the ignition switch to ON position.
7. Verify that the air bag system warning light illuminates for **approximately 6 seconds** and then goes off.
  - If the air bag system warning light does not operate in the manner described above, there are malfunctions in the system. Inspect the system using the on-board diagnostic function. (See 08-02-2 FOREWORD.)

### Connector Removal Note

1. Slide the connector cover toward the harness and then disconnect the connector from the side air bag sensor.

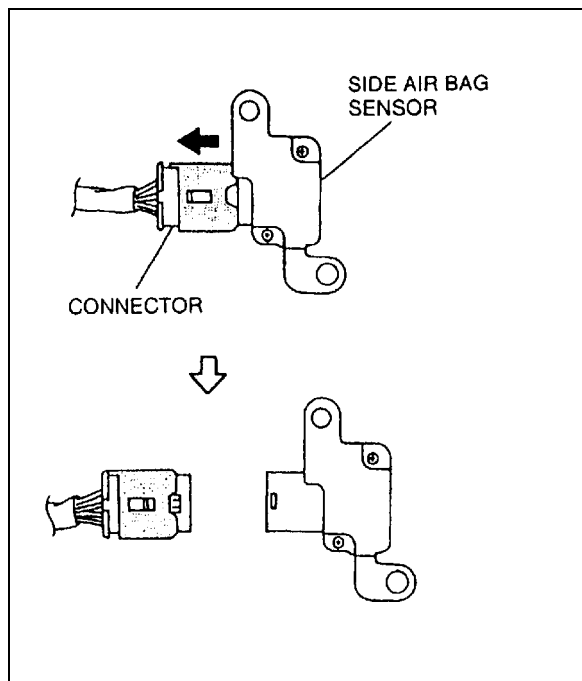

08-10

### Connector Installation Note

1. Attach the connector to the side air bag sensor.
2. Connect the connector by attaching it to the side air bag sensor while lifting up the lock on the connector with a flathead screwdriver.

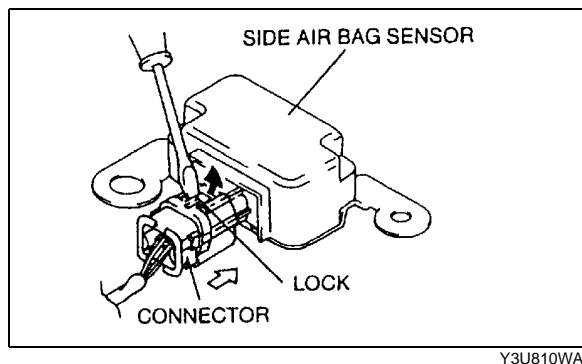

# AIR BAG SYSTEM

## SAS CONTROL MODULE REMOVAL/INSTALLATION

A3U081057030W01

### Warning

- Handling the SAS control module improperly can accidentally deploy the air bag modules, which may seriously injure you. Read AIR BAG SYSTEM SERVICE WARNINGS before handling the SAS control module. (See 08-10-3 AIR BAG SYSTEM SERVICE WARNINGS.)

1. Turn the ignition switch to LOCK position.
2. Disconnect the negative battery cable and wait for **more than 1 minute**.
3. Remove the side walls.
4. Remove in the order indicated in the table.

1	Connector
2	Bolt
3	SAS control module

5. Install in the reverse order of removal.
6. Turn the ignition switch to ON position.
7. Verify that the air bag system warning light illuminates for **approximately 6 seconds** and then goes off.

- If the air bag system warning light does not operate in the manner described above, there are malfunctions in the system. Inspect the system using the on-board diagnostic function. (See 08-02-2 FOREWORD.)

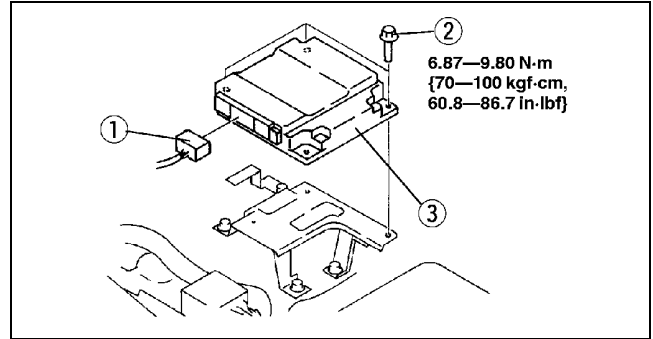

X3U810WAC

### Note

- When a new SAS control module has been installed, the air bag system warning light flashes continuously if there aren't any malfunctions in the system. Perform the air bag module deployment authorization procedure. (See 08-10-13 AIR BAG MODULE AND PRE-TENSIONER SEAT BELT DEPLOYMENT AUTHORIZATION PROCEDURES.)

## SAS CONTROL MODULE BRACKET REMOVAL/INSTALLATION

A3U081057030W02

1. Remove the SAS control module. (See 08-10-12 SAS CONTROL MODULE REMOVAL/INSTALLATION.)
2. Remove in the order indicated in the table.

1	Nut
2	SAS control module bracket

3. Install in the reverse order of removal.

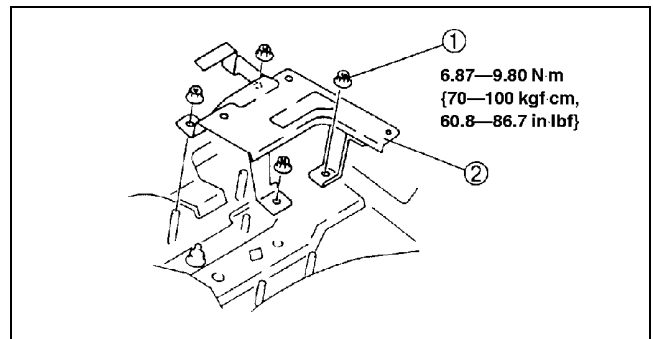

X3U810WAD

# AIR BAG SYSTEM

## AIR BAG MODULE AND PRE-TENSIONER SEAT BELT DEPLOYMENT AUTHORIZATION PROCEDURES

A3U081057000W01

### Note

- When replacing both the SAS control module and side air bag sensor together, perform only “After Replacing SAS Control Module”

### After Replacing SAS Control Module

1. Install a new SAS control module.
  - (1) Turn the ignition switch to ON position.
  - (2) Verify that the air bag system warning light illuminates for **approximately 6 seconds**, goes off, and then flashes continuously.
    - If the air bag system warning light does not flash continuously and indicates a DTC, inspect the system using the on-board diagnostic function. (See 08–02–2 FOREWORD.) When the malfunctions have been repaired and the air bag system warning light flashes continuously, turn the ignition switch to LOCK position. Wait for **approximately 1 second or more** and then turn the ignition switch back to ON position.
    - If the air bag system warning light flashes continuously, turn the ignition switch to LOCK position. Wait for **approximately 1 second or more** and then turn the ignition switch back to ON position.
2. Verify that the air bag system warning light illuminates for **approximately 6 seconds** and then goes off.
  - If the light stays on, perform the deployment authorization procedure again.

### After Replacing Side Air Bag Sensor

1. Install a new side air bag sensor.
2. Turn the ignition switch to ON position.
3. Verify that the air bag system warning light illuminates for **approximately 6 seconds** and then goes off.
  - If the light stays on, perform the deployment authorization procedure again.

08–10

## AIR BAG MODULE AND PRE-TENSIONER SEAT BELT DEPLOYMENT PROCEDURES

A3U081057000W02

### Warning

- **A live (undeployed) air bag module and pre-tensioner seat belt may accidentally deploy when it is disposed of and cause serious injury. Do not dispose of a live (undeployed) air bag module. If the SSTs (Deployment tool and Adapter harness) are not available, consult the nearest Mazda representative for assistance.**

### Caution

- **Deploying the air bag modules inside the vehicle may cause damage to the vehicle interior. When the vehicle is not to be scrapped, always deploy the air bag modules and pre-tensioner seat belts outside the vehicle.**
- When the vehicle is to be scrapped, deploy the air bag modules and pre-tensioner seat belts inside the vehicle. (See 08–10–13 Deployment Procedure for Inside of Vehicle.)
- When the vehicle is not to be scrapped, deploy the air bag modules and pre-tensioner seat belts outside the vehicle. (See 08–10–16 Deployment Procedure for Outside of Vehicle.)

### Note

- When disposing of a deployed air bag module, refer to air bag module and pre-tensioner seat belt disposal procedure. (See 08–10–23 AIR BAG MODULE AND PRE-TENSIONER SEAT BELT DISPOSAL PROCEDURES.)

### Deployment Procedure for Inside of Vehicle

1. Inspect the **SST** (Deployment tool). (See 08–10–24 INSPECTION OF SST (DEPLOYMENT TOOL).)
2. Move the vehicle to an open space, away from strong winds, and close all of the vehicle's doors and windows.
3. Turn the ignition switch to LOCK position.
4. Disconnect the negative battery cable and wait for **more than 1 minute**.
5. Follow the appropriate procedure for deploying the driver-side air bag module, passenger-side air bag module, or side air bag module.

# AIR BAG SYSTEM

## Driver-side air bag module

1. Remove the column cover.
2. Disconnect the clock spring connector.
3. Connect the **SST** (Adapter harness) to the clock spring as shown in the figure.

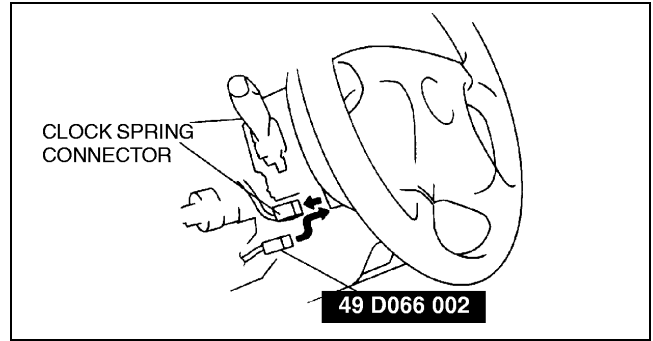

4. Connect the **SST** (Deployment tool) to the **SST** (Adapter harness).
5. Connect the red clip of the **SST** (Deployment tool) to the positive battery terminal and the black clip to the negative battery terminal.
6. Verify that the red light on the **SST** (Deployment tool) is illuminated.
7. Make sure all persons are standing **at least 6 m {20 ft}** away from the vehicle.

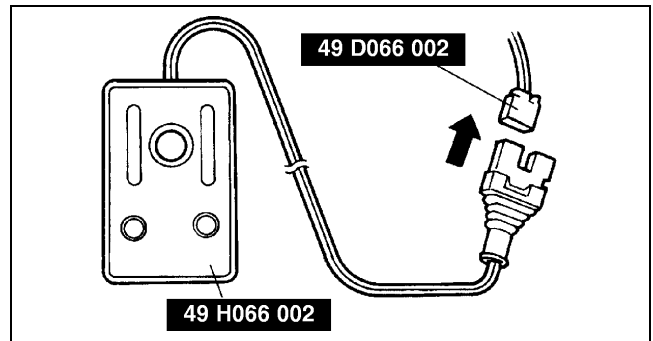

8. Press the activation switch on the **SST** (Deployment tool) to deploy the driver-side air bag module.

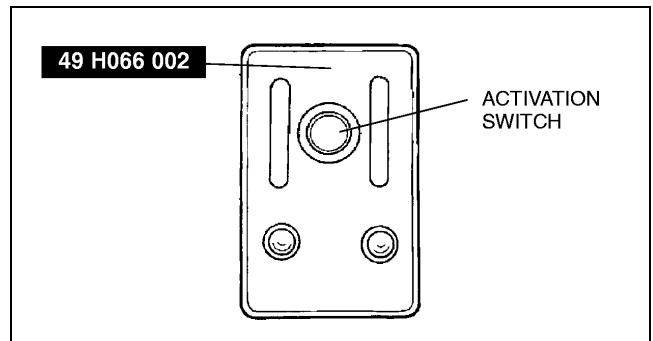

## Passenger-side air bag module

1. Remove the glove compartment.
2. Disconnect the passenger-side air bag module connector.
3. Connect the **SST** (Adapter harness) to the passenger-side air bag module as shown in the figure.

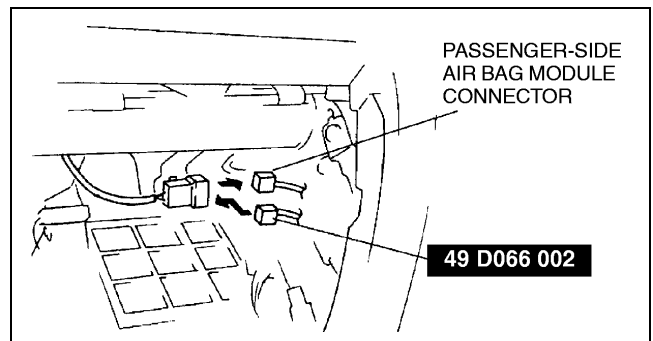



## AIR BAG SYSTEM

4. Connect the **SST** (Deployment tool) to the **SST** (Adapter harness).
5. Connect the red clip of the **SST** (Deployment tool) to the positive battery terminal and the black clip to the negative battery terminal.
6. Verify that the red light on the **SST** (Deployment tool) is illuminated.
7. Make sure all persons are standing **at least 6 m {20 ft}** away from the vehicle.

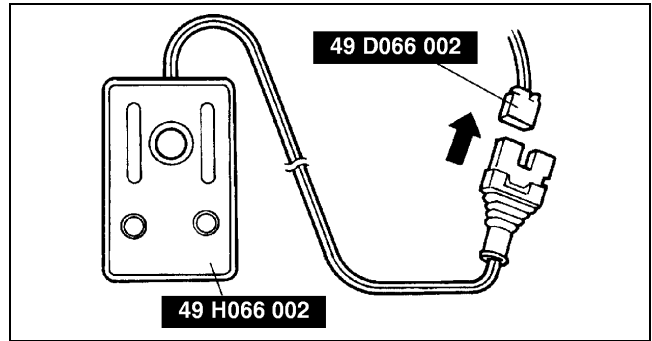

8. Press the activation switch on the **SST** (Deployment tool) to deploy the passenger-side air bag module.

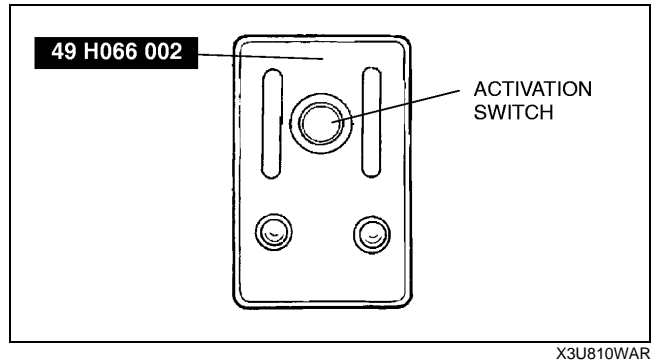

### Side air bag module

1. Disconnect the side air bag module connector.
2. Connect the **SST** (Adapter harness) to the side air bag module.

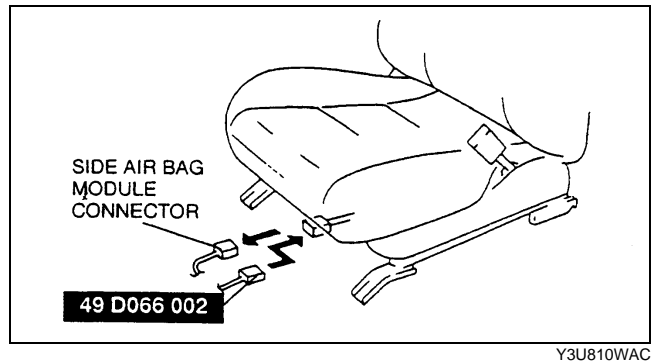

3. Connect the **SST** (Deployment tool) to the **SST** (Adapter harness).
4. Connect the red clip of the **SST** (Deployment tool) to the positive battery terminal and the black clip to the negative battery terminal.
5. Verify that the red light on the **SST** (Deployment tool) is illuminated.
6. Make sure all persons are standing **at least 6 m {20ft}** from the vehicle.

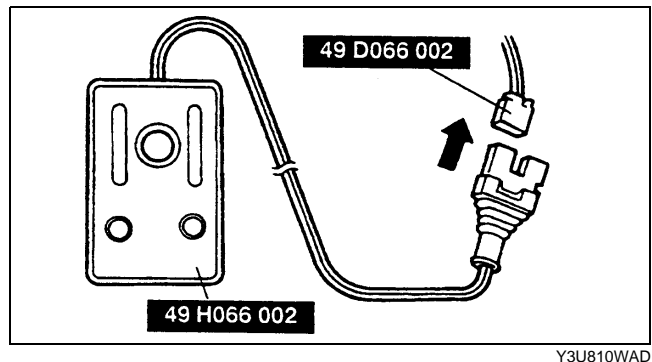

## AIR BAG SYSTEM

7. Press the activation switch on the **SST** (Deployment tool) to deploy the side air bag module.

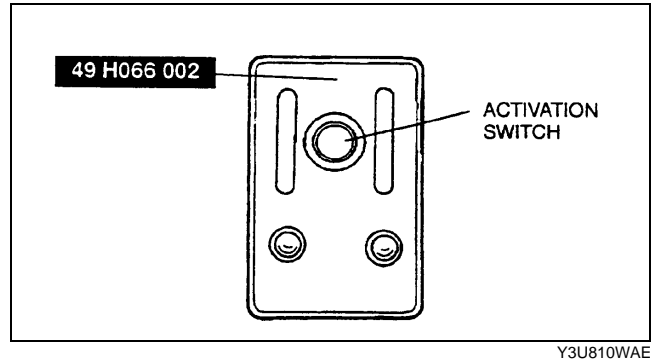

### Pre-tensioner seat belt

1. Remove the B-pillar lower trim.
2. Remove the pre-tensioner seat belt and connect the **SST** (49 D066 003) to it as shown in the figure.
3. Install the pre-tensioner seat belt.

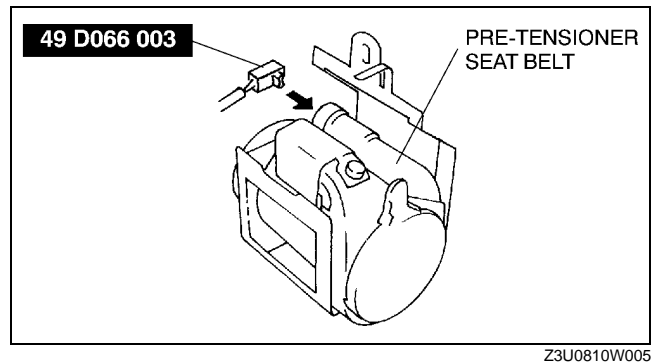

4. Connect the **SST** (49 H066 002) to the **SST** (49 D066 003).
5. Connect the red clip of the **SST** (49 H066 002) to the positive battery terminal and the black clip to the negative battery terminal.
6. Verify that the red light on the **SST** (49 H066 002) is illuminated.
7. Make sure all persons are standing **at least 6 m {20 ft}** from the vehicle.

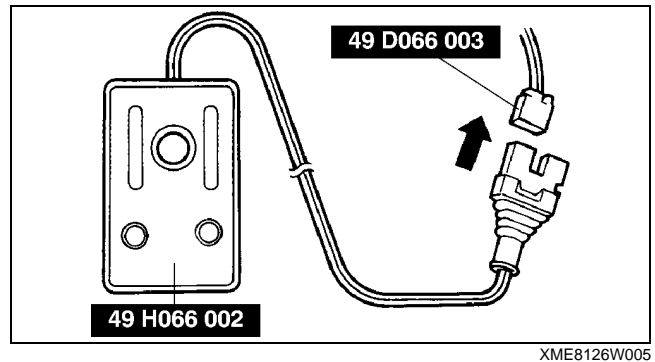

8. Press the activation switch on the **SST** (49 H066 002) to deploy the pre-tensioner seat belt.

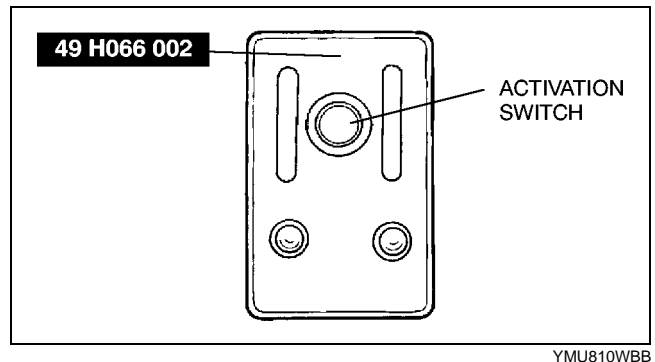

### Deployment Procedure for Outside of Vehicle

1. Inspect the **SST** (Deployment tool). (See 08-10-24 INSPECTION OF SST (DEPLOYMENT TOOL).)
2. Turn the ignition switch to LOCK position.
3. Disconnect the negative battery cable and wait for **more than 1 minute**.
4. Follow the appropriate procedure for deploying the driver-side air bag module, passenger-side air bag module, or side air bag module.

# AIR BAG SYSTEM

## Driver-side air bag module

1. Remove the driver-side air bag module. (See 08-10-5 DRIVER-SIDE AIR BAG MODULE REMOVAL/INSTALLATION.)
2. Place the driver-side air bag module on the center of the wheel with the module facing up. See the illustration below.
  - To secure the air bag module to the wheel, wrap the wire harness through the wheel and the bolt installation hole **at least 4 times**.

### Warning

- **If the air bag module is not properly installed to the wheel, serious injury may occur when the module is deployed. When installing the air bag module to the wheel, make sure the module is facing up.**

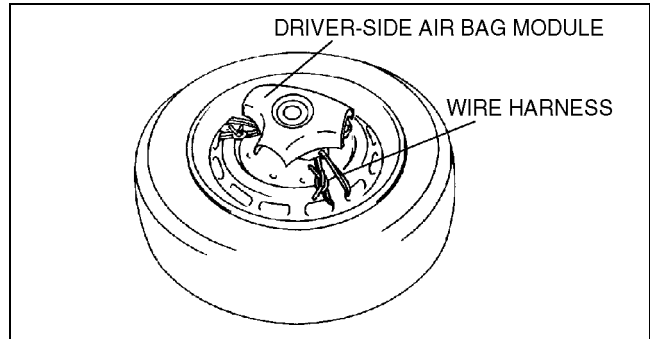

A3U0810W102

3. Connect the **SST** (Adapter harness) to the driver-side air bag module as shown in the figure.

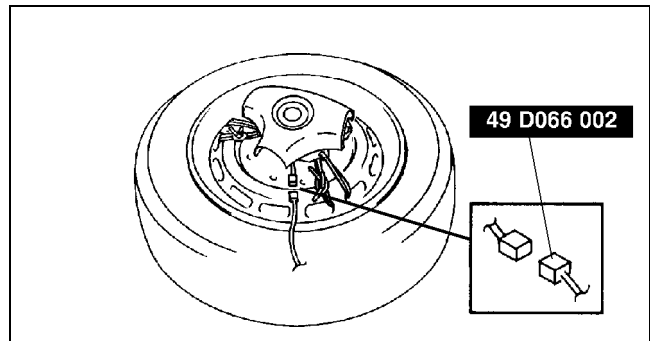

A3U0810W103

4. Stack 3 tires on top of the tire with the air bag module. Stack another tire that has a wheel on top of the 4 tires.

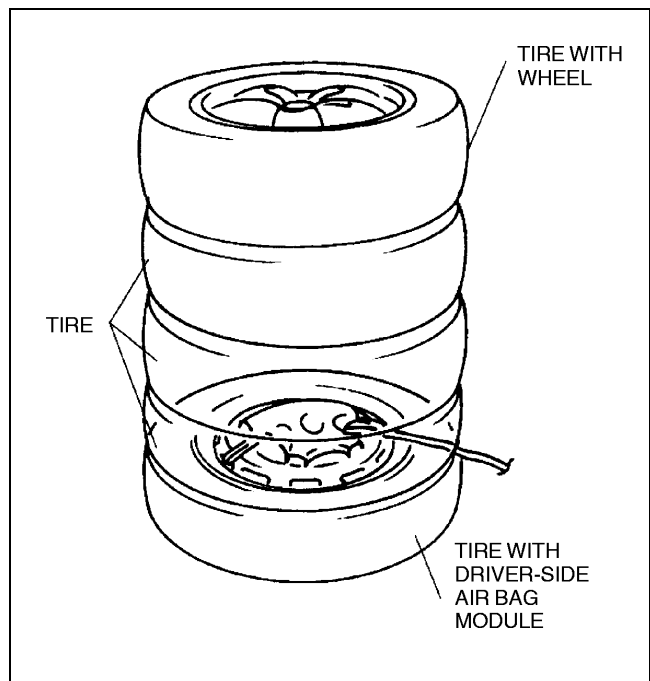

X3U810WAW

08-10

## AIR BAG SYSTEM

5. Tie all tires together with wire.

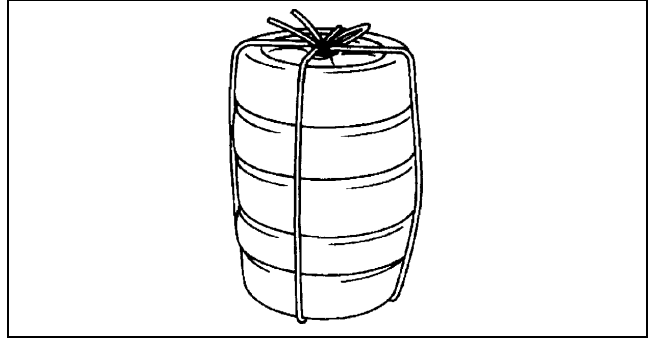

X3U810WAX

6. Connect the **SST** (Deployment tool) to the **SST** (Adapter harness).
7. Connect the red clip of the **SST** (Deployment tool) to the positive battery terminal and the black clip to the negative battery terminal.
8. Verify that the red light on the **SST** (Deployment tool) is illuminated.
9. Make sure all persons are standing **at least 6 m {20 ft}** away from the tires.

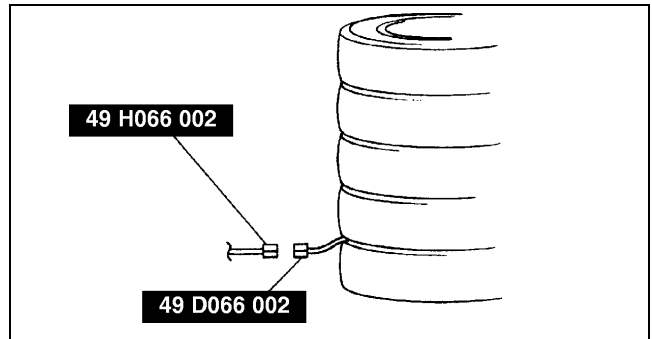

X3U810WAY

10. Press the activation switch on the **SST** (Deployment tool) to deploy the driver-side air bag module.

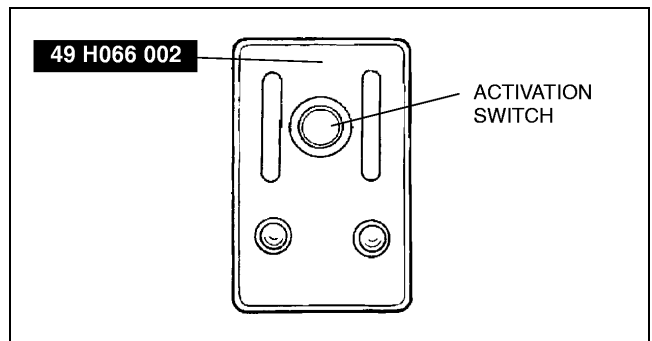

X3U810WAZ

### Passenger-side air bag module

1. Remove the passenger-side air bag module. (See 08-10-6 PASSENGER-SIDE AIR BAG MODULE REMOVAL/INSTALLATION.)
2. Install the bolts to the passenger-side air bag module.

#### Warning

- If the air bag module is not properly installed to the tire, serious injury may occur when the module is deployed. When installing the air bag module to the tire, make sure the module is facing the center of the tire.

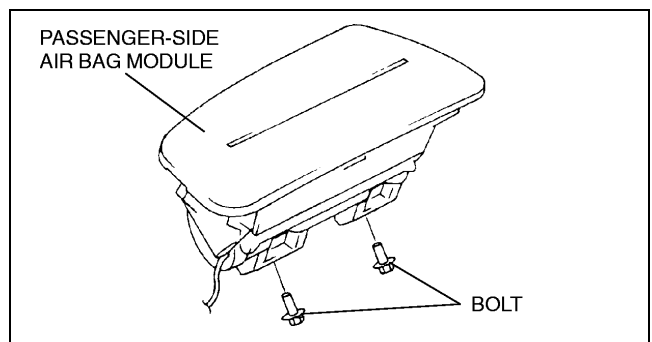

X3U810WB0

# AIR BAG SYSTEM

3. Tie the passenger-side air bag module to a tire with the module facing the center of the tire. Wrap the wire harness through the tire and around the bolts **at least four times**.

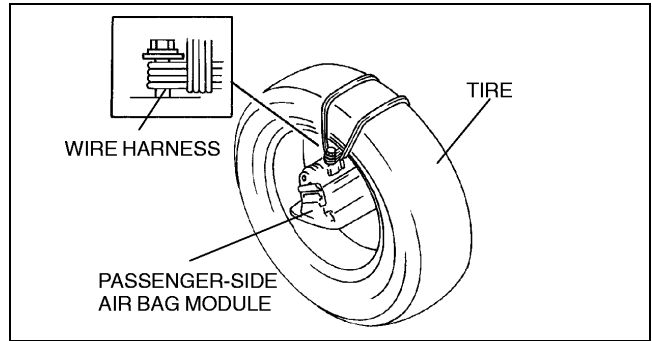

X3U810WB1

4. Connect the **SST** (Adapter harness) to the passenger-side air bag module as shown in the figure.

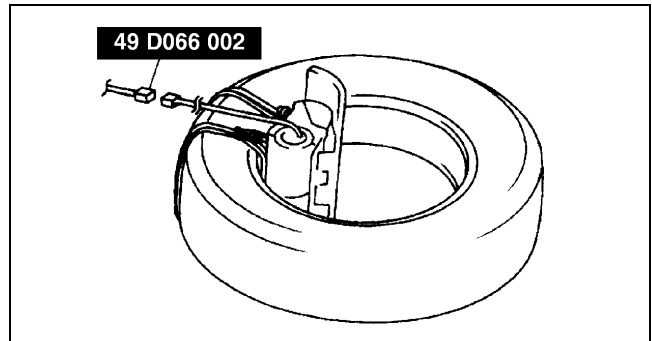

X3U810WB2

5. Stack the tire with the passenger-side air bag module on top of 2 tires. Stack a tire on top of the 3 tires. Stack another tire that has a wheel on top of the 4 tires.

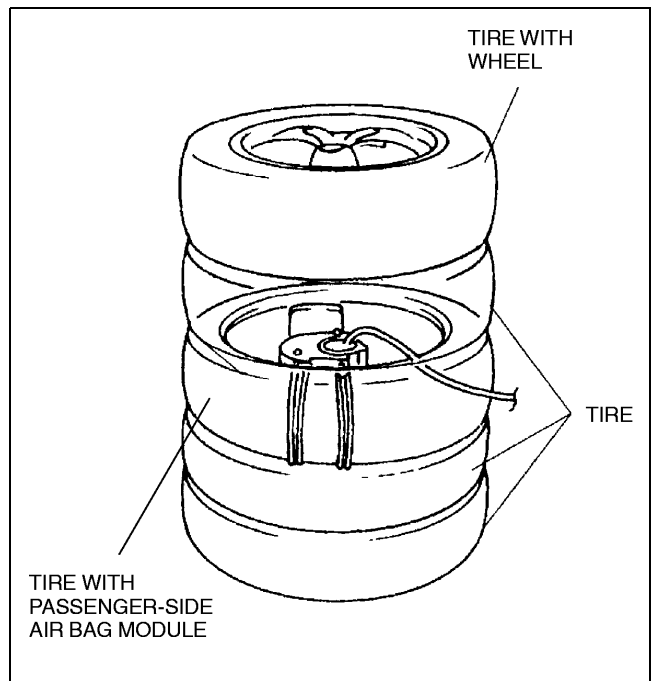

X3U810WB3

6. Tie all tires together with wire.

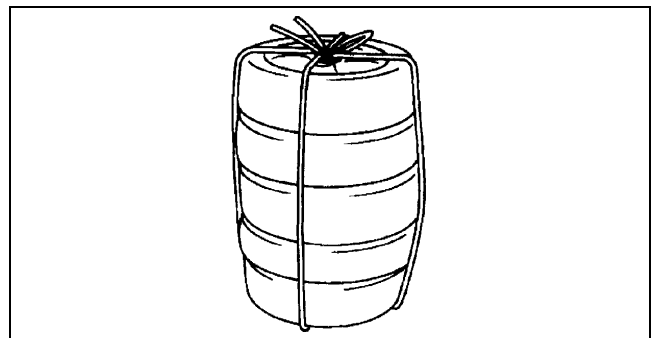

08-10

## AIR BAG SYSTEM

7. Connect the **SST** (Deployment tool) to the **SST** (Adapter harness).
8. Connect the red clip of the **SST** (Deployment tool) to the positive battery terminal and the black clip to the negative battery terminal.
9. Verify that the red light on the **SST** (Deployment tool) is illuminated.
10. Make sure all persons are standing **at least 6 m {20 ft}** away from the tires.

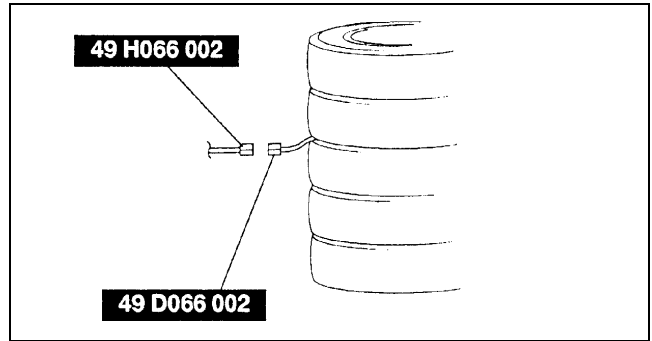

X3U810WB5

11. Press the activation switch on the **SST** (Deployment tool) to deploy the passenger-side air bag module.

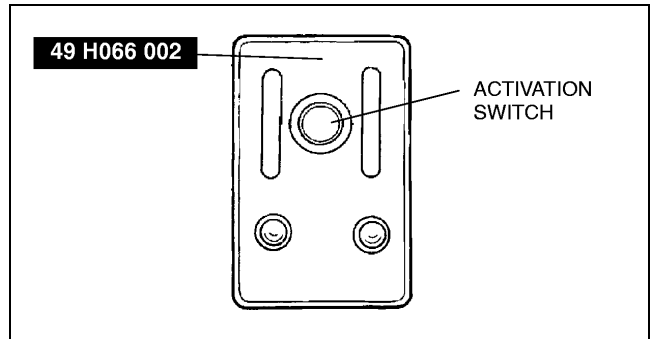

X3U810WB6

### Side air bag module

1. Remove the side air bag module. (See 08–10–7 SIDE AIR BAG MODULE REMOVAL/INSTALLATION.)
2. Install the nuts to the side air bag module.

#### Warning

- If the air bag module is not properly installed to the tire, serious injury may occur when the module is deployed. When installing the air bag module to the tire, make sure the module is facing the center of the tire.

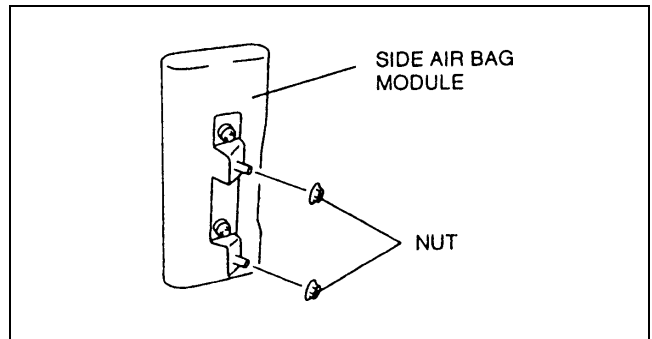

Y3U810WAF

3. Tie the side air bag module to the tire with the module facing the center of the tire. Wrap the wire harness through the tire and around the nuts **at least 4 times**.

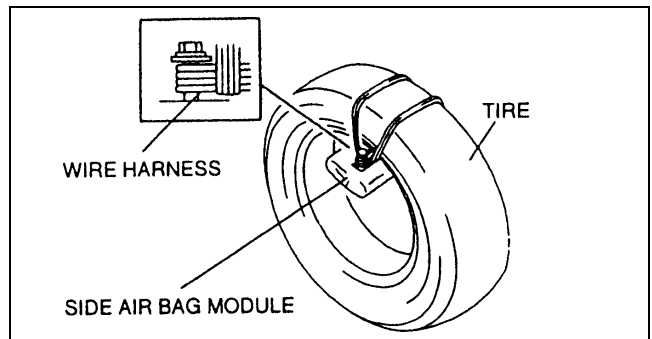

Y3U810WAG

## AIR BAG SYSTEM

4. Connect the **SST** (Adapter harness) to the side air bag module as shown in the figure.

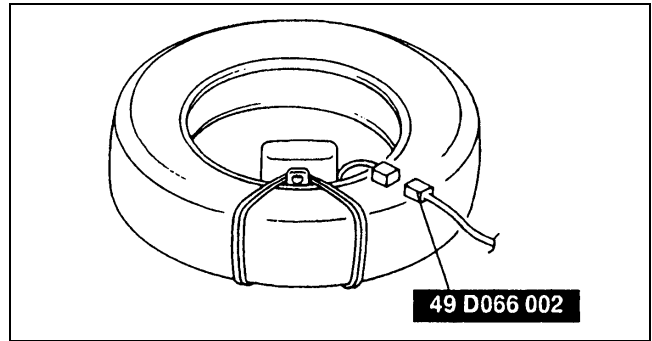

Y3U810WAH

5. Stack the tire with the side air bag module on top of 2 tires. Stack a tire on top of 3 tires. Stack another tire that has a wheel on top of the 4 tires.

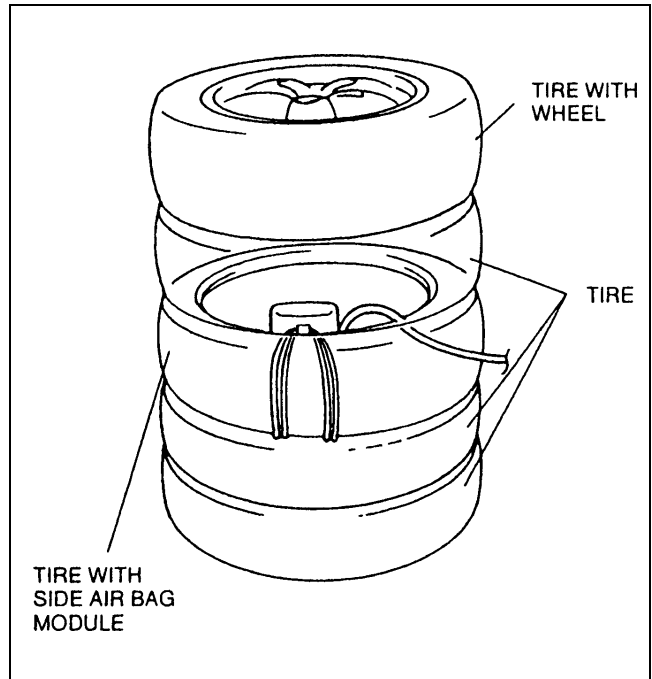

Y3U810WAJ

6. Tie all tires together with wire.

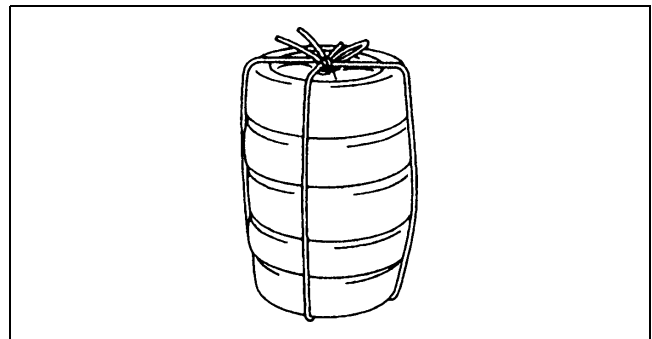

Y3U810WAK

7. Connect the **SST** (Deployment tool) to the **SST** (Adapter harness).
8. Connect the red clip of the **SST** (Deployment tool) to the positive battery terminal and the black clip to the negative battery terminal.
9. Verify that the red light on the **SST** (Deployment tool) is illuminated.
10. Make sure all persons are standing **at least 6 m {20ft}** from the tires.

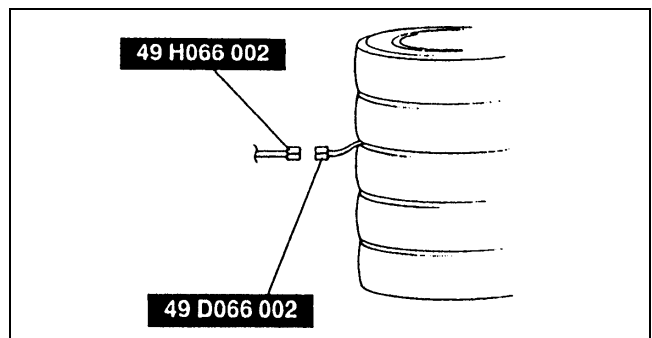

Y3U810WAL

08-10

## AIR BAG SYSTEM

11. Press the activation switch on the **SST** (Deployment tool) to deploy the side air bag module.

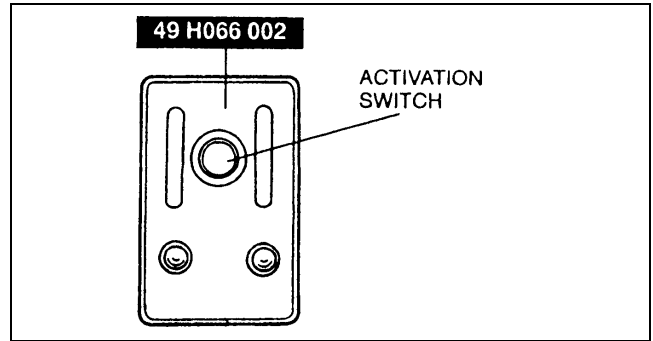

Y3U810WAM

### Pre-tensioner seat belt

1. Remove the pre-tensioner seat belt.
2. Connect the **SST** (49 D066 003) to the pre-tensioner seat belt as shown in the figure.

#### Warning

- If the pre-tensioner seat belt is not properly installed to the tire, serious injury may occur when the pre-tensioner part is deployed. When installing the pre-tensioner seat belt to the tire, make sure the pre-tensioner part is inside the tire.

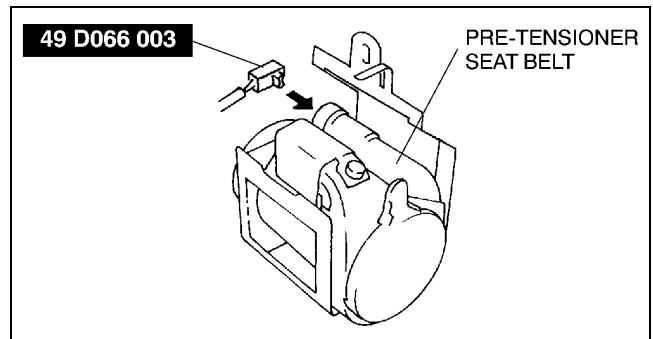

Z3U0810W005

3. With the pre-tensioner part inside the tire, tie the pre-tensioner seat belt to the tire. Wrap the wire harness through the tire and around the pre-tensioner seat belt **at least four times**.

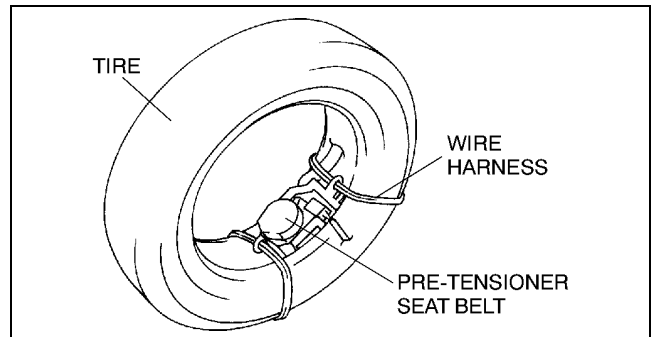

Z3U0810W006

4. Stack the tire with the pre-tensioner seat belt on top of two tires. Stack a tire on top of the three tires. Stack another tire that has a wheel on top of the four tires.

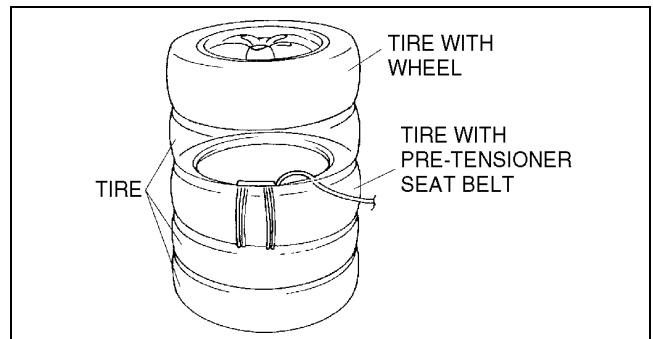

YLE8130W201



## AIR BAG SYSTEM

5. Tie all tires together with wire.

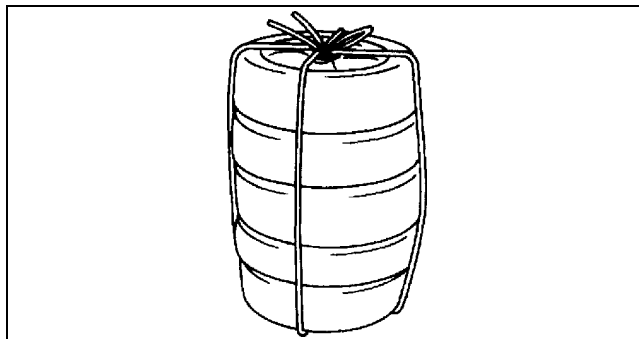

XME8126W008

6. Connect the **SST** (49 H066 002) to the **SST** (49 D066 003).
7. Connect the red clip of the **SST** (49 H066 002) to the positive battery terminal and the black clip to the negative battery terminal.
8. Verify that the red light on the **SST** (49 H066 002) is illuminated.
9. Make sure all persons are standing **at least 6 m {20 ft}** from the vehicle.

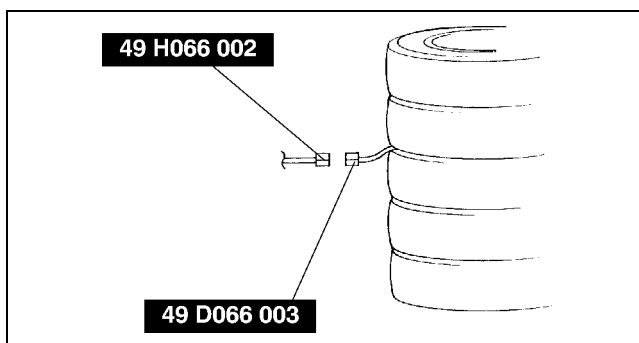

XME8126W009

10. Press the activation switch on the **SST** (49 H066 002) to deploy the pre-tensioner seat belt.

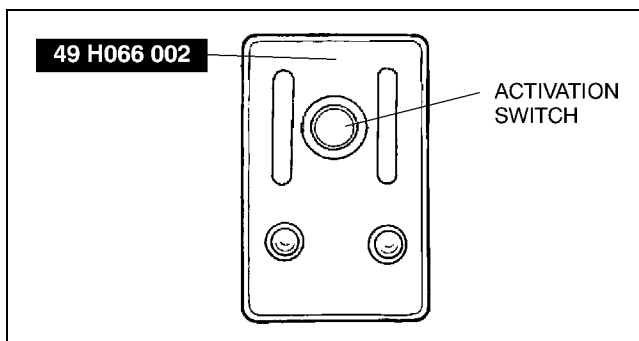

XME8126W010

08-10

### AIR BAG MODULE AND PRE-TENSIONER SEAT BELT DISPOSAL PROCEDURES

A3U081057000W03

#### Warning

- Before scrapping a vehicle with a live (undeployed) air bag module and pre-tensioner seat belt, deploy the air bag module. Never dispose of a live (undeployed) air bag module and pre-tensioner seat belt.
- The air bag module and pre-tensioner seat belt are very hot immediately after it is deployed. You can get burned. Do not touch the air bag module and pre-tensioner seat belt for at least 15 minutes after deployment.
- Pouring water on the deployed air bag module and pre-tensioner seat belt are dangerous. The water will mix with the residual gases to form a gas that can make breathing difficult. Do not pour water on the deployed air bag module and pre-tensioner seat belt.
- The deployed air bag module and pre-tensioner seat belt may contain deposits of sodium hydroxide, a caustic by product of the gas-generated combustion. If this substance gets into your eyes or on your hands, it can cause irritation and itching. When handling the deployed air bag module and pre-tensioner seat belt, wear gloves and safety glasses.

1. Put on gloves and safety glasses.
2. Put the deployed air bag module or pre-tensioner seat belt in a plastic bag, seal it, and then dispose of it.
3. Wash your hands after removing your gloves.

# AIR BAG SYSTEM

## INSPECTION OF SST (DEPLOYMENT TOOL)

- Use the **SST** (Deployment tool) to deploy a live (undeployed) air bag module before disposing of it.
- Before using the **SST** (Deployment tool), inspect its operation.

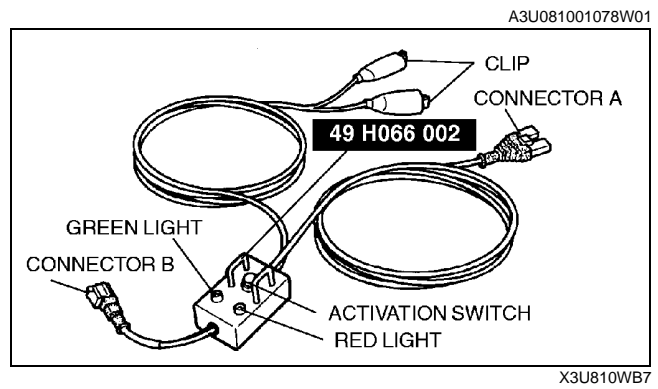

### Inspection Procedure

1. Follow the steps below to verify that the **SST** (Deployment tool) is operating correctly.
  - If not as specified, do not use the **SST** (Deployment tool) because it may cause the air bag module to unexpectedly deploy upon connection to the air bag module.

Step	Inspection procedure	Light condition	
		Green	Red
1	Connect red clip to positive battery terminal and black clip to negative battery terminal.	On	Off
2	Connect connectors A and B of <b>SST</b> (Deployment tool).	Off	On
3	Press activation switch.	On	Off

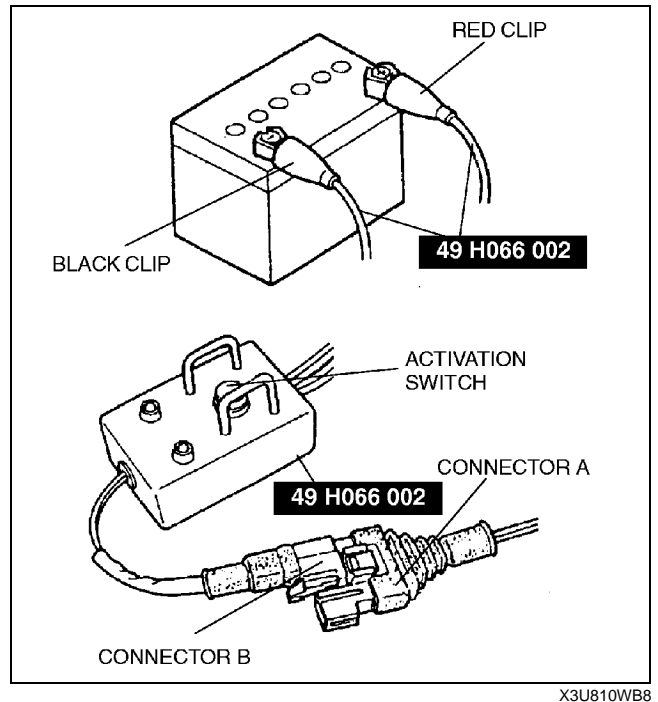

# 08-11 SEAT BELT

**FRONT SEAT BELT**  
 REMOVAL/INSTALLATION ..... 08-11-1

**REAR SEAT BELT**  
 REMOVAL/INSTALLATION ..... 08-11-1  
 4SD ..... 08-11-2  
 5HB ..... 08-11-2

**REAR CENTER SEAT BELT**  
 REMOVAL/INSTALLATION ..... 08-11-3  
 4SD ..... 08-11-3  
 5HB ..... 08-11-3

**FRONT BUCKLE**  
 REMOVAL/INSTALLATION ..... 08-11-3

**REAR BUCKLE**  
 REMOVAL/INSTALLATION ..... 08-11-4

**SEAT BELT INSPECTION** ..... 08-11-4  
 Belt ..... 08-11-4  
 ELR ..... 08-11-4  
 ALR ..... 08-11-4

**BUCKLE SWITCH INSPECTION** ..... 08-11-5

**CHILD RESTRAINT SEAT ANCHOR**  
 REMOVAL/INSTALLATION ..... 08-11-5  
 ISOFIX Anchor ..... 08-11-5  
 Tether Anchor ..... 08-11-5

## FRONT SEAT BELT REMOVAL/INSTALLATION

A3U081157630W01

**Warning**

- Handling the front seat belt (pre-tensioner seat belt) or the side air bag sensor improperly can accidentally deploy the pre-tensioner or the side air bag module, which may seriously injure you. Read SERVICE WARNINGS before handling the front seat belt or working around the B-pillar areas. (See 08-10-3 AIR BAG SYSTEM SERVICE WARNINGS.)

**Note**

- The side air bag sensor is located in the B-pillar.

**Caution**

- The ELR has a spring that will unwind if the retractor's cover is removed. The spring cannot be rewound by hand. If this occurs, the ELR will not work properly. Therefore, do not disassemble the retractor.

1. Disconnect the negative battery cable.
2. Remove the B-pillar lower trim. (See 09-17-10 B-PILLAR LOWER TRIM REMOVAL.) (See 09-17-11 B-PILLAR LOWER TRIM INSTALLATION.)
3. Remove in the order indicated in the table.

1	Anchor cover
2	Front seat belt

4. Install in the reverse order of removal.

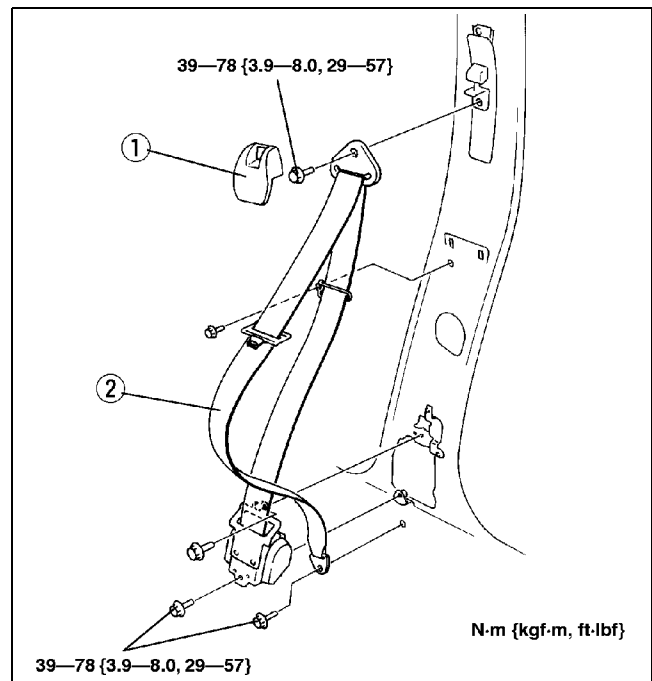

X3U811WA0

# SEAT BELT

## REAR SEAT BELT REMOVAL/INSTALLATION

A3U081157730W01

### Caution

- The ELR has a spring that will unwind if the retractor's cover is removed. The spring cannot be rewound by hand. If this occurs, the ELR will not work properly. Therefore, do not disassemble the retractor.

### 4SD

1. Remove the rear package trim.
2. Remove the bolts, then remove the rear seat belt.
3. Install in the reverse order of removal.

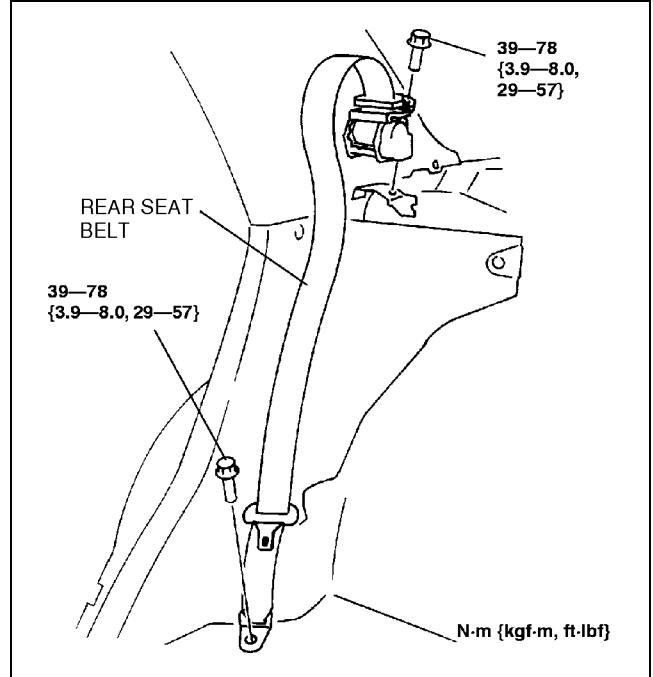

Z3U0811W004

### 5HB

1. Remove the trunk side trim.
2. Remove the bolts, then remove the rear seat belt.
3. Install in the reverse order of removal.

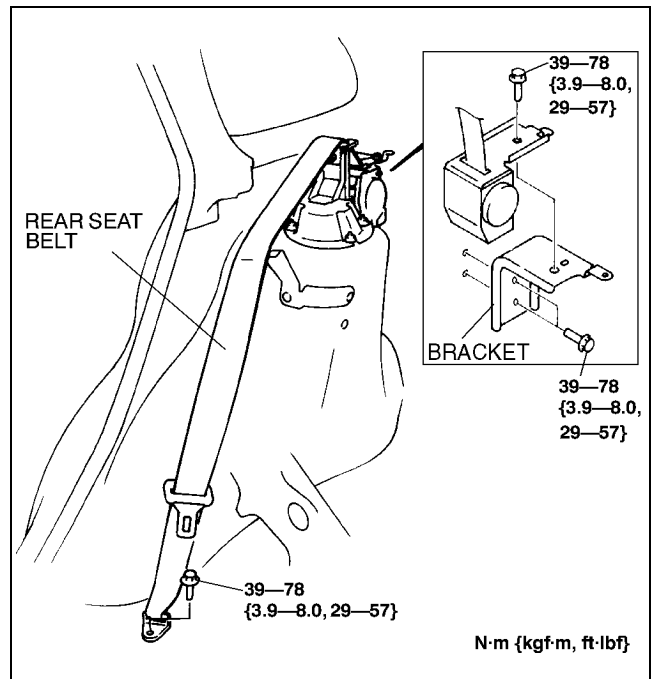

A3U0811W001

# SEAT BELT

## REAR CENTER SEAT BELT REMOVAL/INSTALLATION

A3U081157730W02

### Caution

- The ELR has a spring that will unwind if the retractor's cover is removed. The spring cannot be rewound by hand. If this occurs, the ELR will not work properly. Therefore, do not disassemble the retractor.

### 4SD

1. Remove the rear package trim.
2. Remove the bolt, then remove the rear center seat belt.
3. Install in the reverse order of removal.

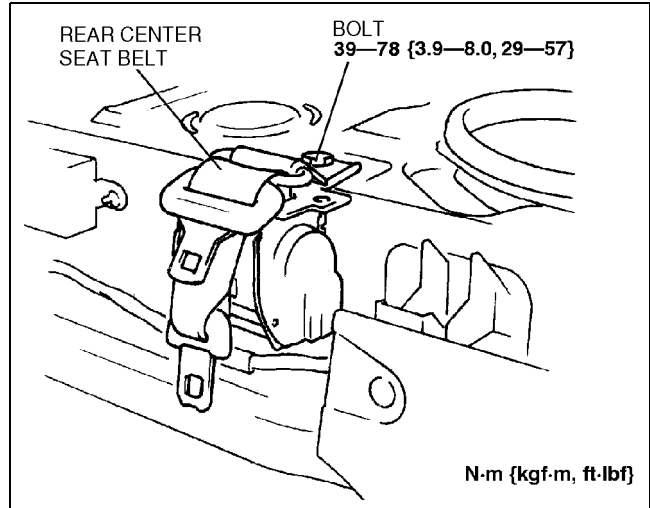

Z3U0811W002

08-11

### 5HB

1. Remove the trunk side trim.
2. Remove the bolts, then remove the rear center seat belt.
3. Install in the reverse order of removal.

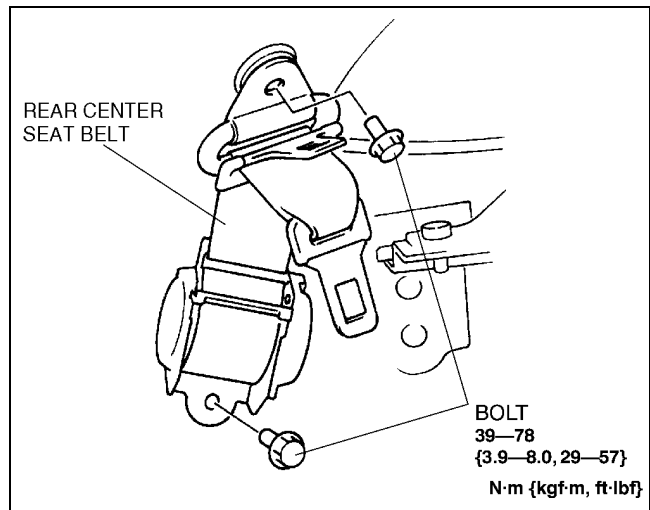

A3U0811W002

A3U081157620W01

## FRONT BUCKLE REMOVAL/INSTALLATION

1. Disconnect the negative battery cable.
2. Remove in the order indicated in the table.

1	Connector
2	Front buckle

3. Install in the reverse order of removal.

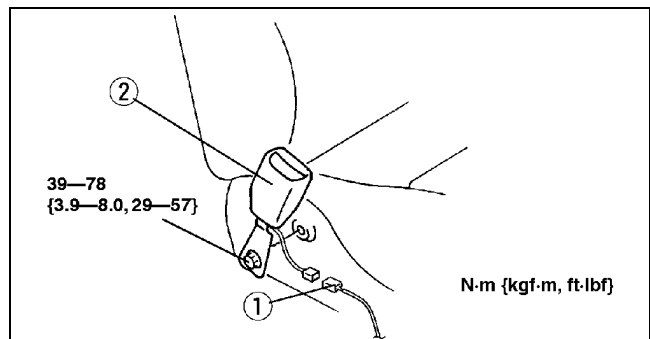

X3U811WA3

# SEAT BELT

## REAR BUCKLE REMOVAL/INSTALLATION

A3U081157720W01

1. For 4SD, remove the rear seat cushion. For 5HB, lift up the rear seat cushion.
2. Remove the bolt, then remove the rear buckle.
3. Install in the reverse order of removal.

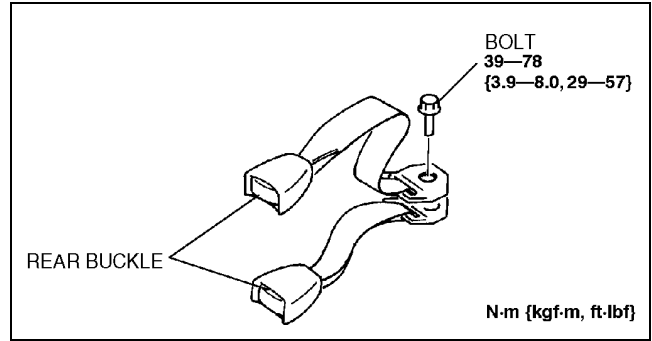

Z3U0811W001

## SEAT BELT INSPECTION

A3U081157630W02

### Belt

1. Confirm that the seat belt is installed correctly.
2. Inspect the seat belt for damage and deformation of metal parts.
  - If any damage is found, replace as necessary.
3. Replace the seat belt if there is any faulty area.

### ELR

1. Verify that the belt can be pulled out smoothly, and that it moves smoothly when wound.
  - If not as specified, replace the seat belt.
2. Verify that the retractor locks when the belt is pulled quickly.
  - If not as specified, replace the seat belt.
3. Remove the retractor. (See 08-11-1 FRONT SEAT BELT REMOVAL/INSTALLATION.) (See 08-11-2 REAR SEAT BELT REMOVAL/INSTALLATION.) (See 08-11-3 REAR CENTER SEAT BELT REMOVAL/INSTALLATION.)
4. Hold the retractor as it would be installed.
5. Slowly incline the retractor while pulling out the belt.
6. Verify that the retractor lks at approximately 30° inclination.
  - If not as specified, replace the seat belt.

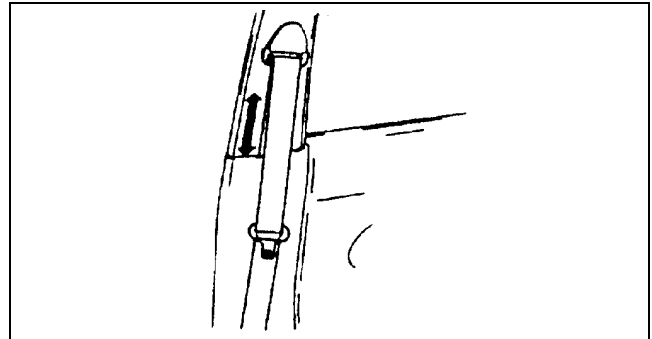

X3U811WA5

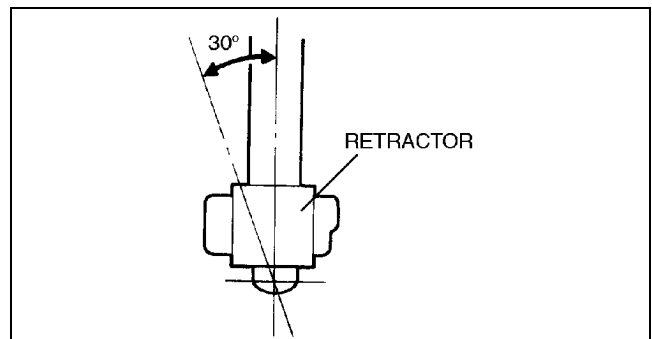

X3U811WA6

### ALR

1. Pull the belt out fully and the lock mode changes from ELR to ALR.
2. Verify that retractor makes a clicking sound as the belt slowly retracts.
  - If no sound is heard, the lock mode has not changed to ALR. If necessary, repeat the above Step 1.
  - If not as specified, replace the seat belt.
3. Verify that the belt locks when pulled.
  - If not as specified, replace the seat belt.
4. Verify that the lock mode changes to ELR when the belt fully retracts.
  - If not as specified, replace the seat belt.

# SEAT BELT

## BUCKLE SWITCH INSPECTION

A3U081157620W02

1. Disconnect the negative battery cable.
2. Disconnect the buckle switch connector.
3. Inspect for continuity between the buckle switch terminals using an ohmmeter.
  - If not as specified, replace the front buckle.

○—○ : Continuity

Seat belt	Terminal	
	A	B
Fastened		
Unfastened	○—○	○—○

X3U811WA7

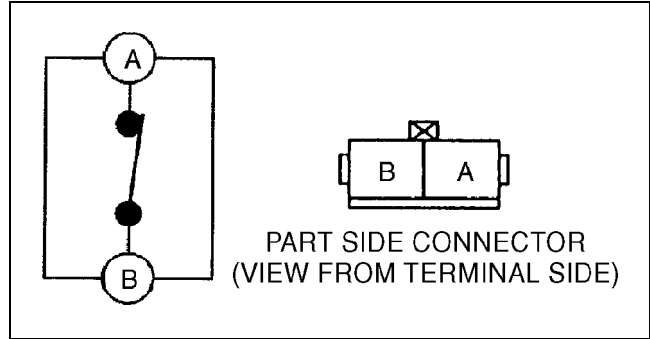

Y3U811WA0

## CHILD RESTRAINT SEAT ANCHOR REMOVAL/INSTALLATION

A3U081157770W01

### ISOFIX Anchor

1. Fold down the rear seat back.
2. Remove the tire house trim.
3. Remove the child restraint seat anchor.
4. Install in the reverse order of removal.

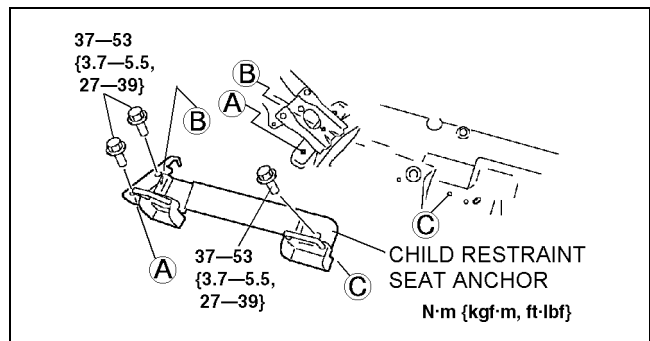

Z3U0811W003

### Tether Anchor

#### 4SD

1. Remove the rear package trim.
2. Remove the bolt, then child restraint seat anchor.
3. Install in the reverse order of removal.

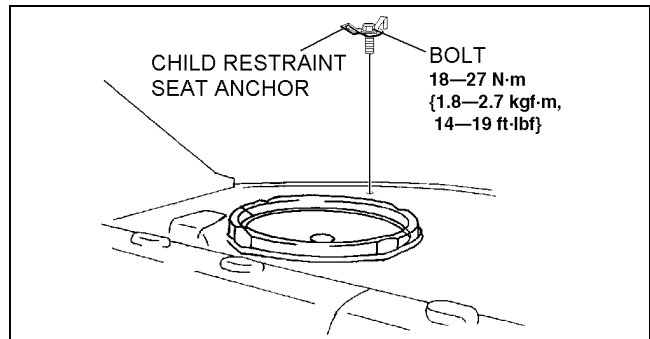

A3U0811W004

#### 5HB

1. Remove the trunk end trim.
2. Remove the bolt, then child restraint seat anchor.
3. Install in the reverse order of removal.

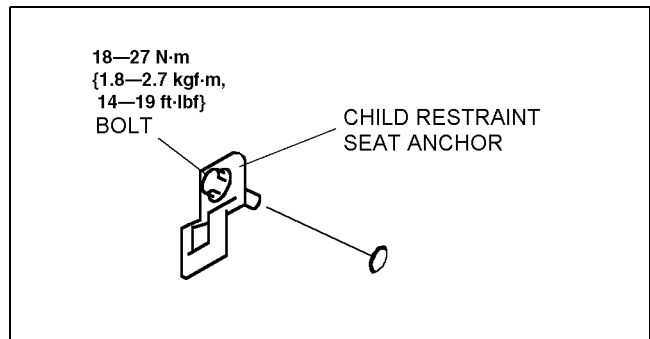



A3U0811W005

**08-60 SERVICE TOOLS**

RESTRAINTS SST ..... 08-60-1

**RESTRAINTS SST**

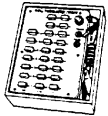
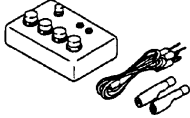
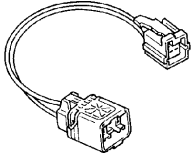
A3U086001045W01

<p>49 H066 002 Deployment tool</p> 	<p>49 0839 285 Fuel and Thermometer checker (Old)</p> 	<p>49 N088 0A0 Fuel and Thermometer checker (New)</p> 
<p>49 D066 002 Adapter harness</p> 	<p>49 D066 003 Adapter harness</p> 	<p>—</p>



# BODY & ACCESSORIES

**09**  
SECTION

ON-BOARD DIAGNOSTIC [POWER DOOR LOCK SYSTEM] . . . . .	09-02A	EXTERIOR TRIM . . . . .	09-16
ON-BOARD DIAGNOSTIC [AUDIO]. . . . .	09-02B	INTERIOR TRIM. . . . .	09-17
BODY PANELS] . . . . .	09-10	LIGHTING SYSTEMS. . . . .	09-18
DOORS AND LIFTGATE . . . . .	09-11	WIPER/WASHER SYSTEM . . . . .	09-19
GLASS/WINDOWS/MIRRORS . . . . .	09-12	ENTERTAINMENT . . . . .	09-20
SEATS . . . . .	09-13	POWER SYSTEMS . . . . .	09-21
SECURITY AND LOCKS . . . . .	09-14	INSTRUMENTATION/DRIVER INFO. . . . .	09-22
SUNROOF . . . . .	09-15	TECHNICAL DATA . . . . .	09-50
		SERVICE TOOLS. . . . .	09-60

## 09-02A ON-BOARD DIAGNOSTIC [POWER DOOR LOCK SYSTEM]

ON-BOARD DIAGNOSTIC FUNCTION [KEYLESS ENTRY SYSTEM] . . . . .	09-02A-2
---	----------

09-02A

# ON-BOARD DIAGNOSTIC [POWER DOOR LOCK SYSTEM]

## ON-BOARD DIAGNOSTIC FUNCTION [KEYLESS ENTRY SYSTEM]

A3U090269000W01

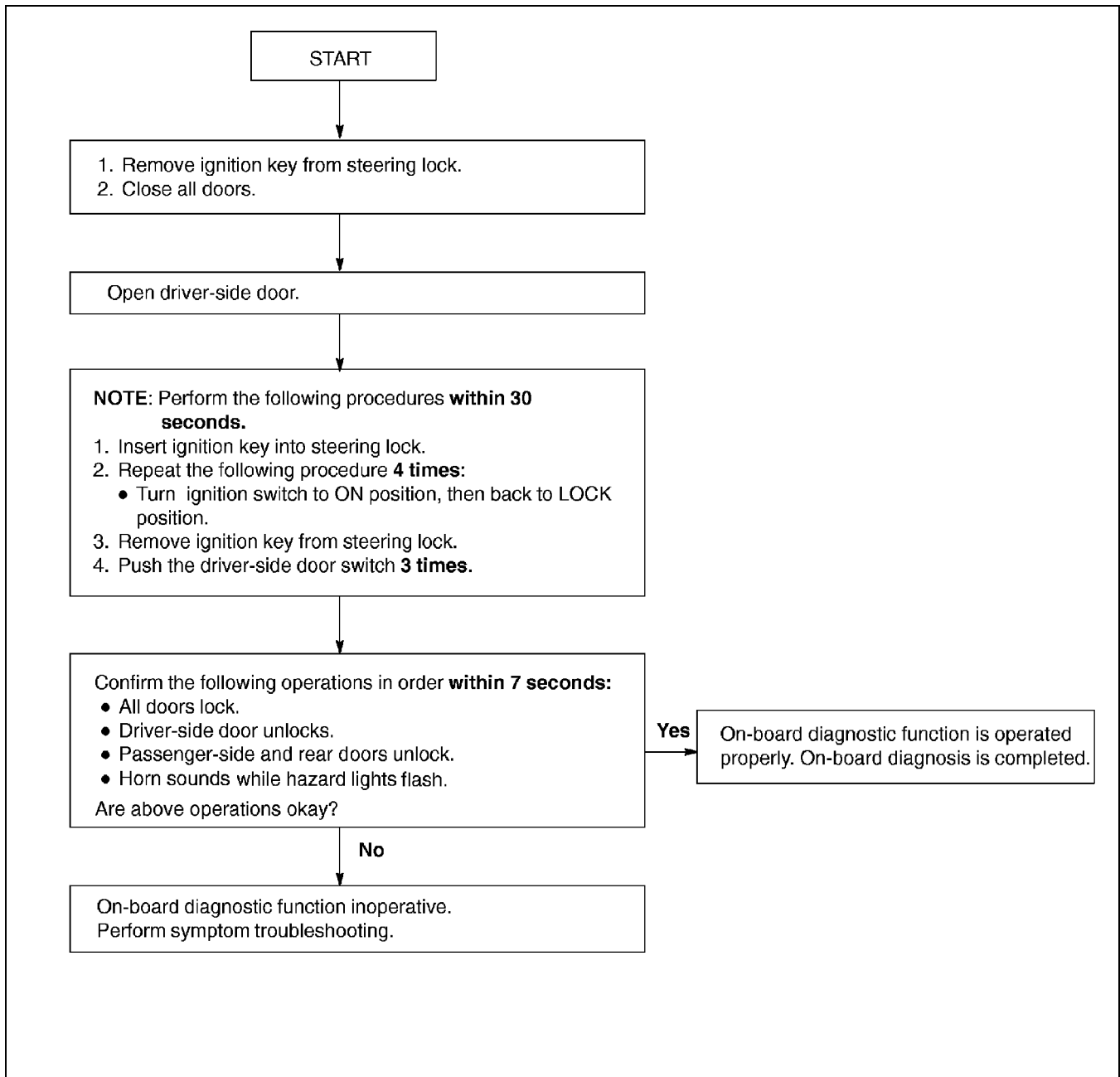

Z3U0902W002

# 09-02B ON-BOARD DIAGNOSTIC [AUDIO]

## STARTING PROCEDURE FOR ON-BOARD

DIAGNOSTIC TEST MODE .....	09-02B-1
<b>SUPPLIER IDENTIFICATION</b>	
PROCEDURE .....	09-02B-1
Identification With Printed	
Numbers/Label .....	09-02B-2
Identification With On-board Diagnostic	
Test Mode .....	09-02B-2
DTC CLEARING PROCEDURE .....	09-02B-2
DTC TABLE .....	09-02B-3
DTC 09:ER22 .....	09-02B-3
DTC 09:ER20 .....	09-02B-4
DTC 00:ER10 .....	09-02B-5
DTC 03:ER10 .....	09-02B-5
DTC 05:ER10 .....	09-02B-6
DTC 06:ER10 .....	09-02B-6
DTC 07:ER10 .....	09-02B-7
DTC 03:ER01 .....	09-02B-7
DTC 03:ER02 .....	09-02B-8

DTC 03:ER07 .....	09-02B-8
DTC 00:ER01 .....	09-02B-9
DTC 00:ER03 .....	09-02B-9
DTC 00:ER04 .....	09-02B-9
DTC 05:ER01 .....	09-02B-10
DTC 05:ER07 .....	09-02B-10
DTC 06:ER01 .....	09-02B-11
DTC 06:ER02 .....	09-02B-11
DTC 06:ER07 .....	09-02B-12
DTC 07:ER01 .....	09-02B-12
DTC 07:ER02 .....	09-02B-13
DTC 07:ER07 .....	09-02B-13
<b>DIAGNOSTIC ASSIST FUNCTION</b> .....	
Structural View .....	09-02B-14
LCD inspection .....	09-02B-14
Button inspection .....	09-02B-15
Speaker inspection .....	09-02B-15
Radio reception condition inspection ..	09-02B-15

## STARTING PROCEDURE FOR ON-BOARD DIAGNOSTIC TEST MODE

A3U090266900W01

### Note

- All DTCs displayed in the on-board diagnostic test mode should be entered on the Audio Exchange Order Form.

09-02B

- Turn the ignition switch to the ACC or ON position.
- First press the POWER button and hold it, then press the AM button and CLOCK button for **2 seconds or more**.

1	AM button
2	CLOCK button
3	SEEK button
4	POWER button

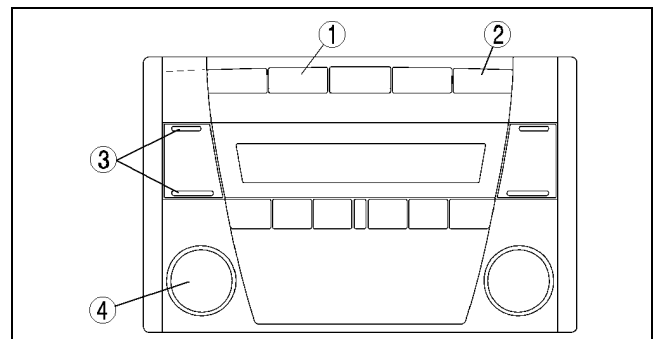

ZLU0920W102

### Note

- If several DTCs are in the memory, they can be displayed by the SEEK button.

- To stop the on-board diagnostic test mode, turn the ignition switch to the LOCK position.

## SUPPLIER IDENTIFICATION PROCEDURE

A3U090266900W02

### Note

- When asking the supplier (service center) for repair or replacement, verify which supplier the module belongs to and enter on the Audio Exchange Order Form. (See Warranty Bulletin Category AD, number 32.) Use the table and illustration below to determine the audio supplier.

# ON-BOARD DIAGNOSTIC [AUDIO]

## Identification With Printed Numbers/Label

### Base unit

- To identify the supplier name, compare the leftmost number of the ID code (4 digits), printed on the upper right corner of the LCD, with the table below.

Audio ID number	Supplier name
1	Panasonic
2	Clarion
4	FMS Audio

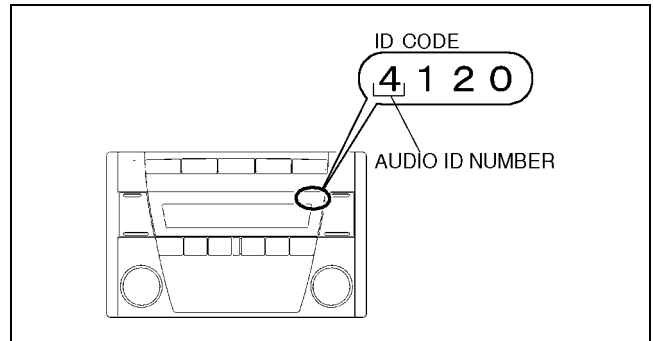

YLE8175W002

### Upper/lower module

- Remove the audio unit.
- Verify the supplier name written on the label attached on each module.

## Identification With On-board Diagnostic Test Mode

- Start the on-board diagnostic test mode.
- Verify the device code and supplier code displayed in the LCD.

### Note

- When no DTCs are in the memory, device code and supplier codes will not be displayed.

Device code	Part name
00	Cassette deck (lower module)
03	CD player (upper module)
05	CD changer (external type)
06	CD changer (upper module)
07	MD player (lower module)
09	Base unit

Supplier code	Supplier name
1	FMS Audio
2	Panasonic
3	Clarion

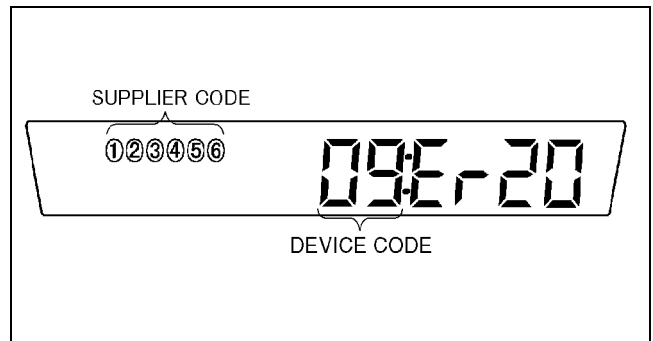

Z3U0920W003

## DTC CLEARING PROCEDURE

A3U090266900W03

- Start the on-board diagnostic test mode.
- First press the POWER button and hold it, then press AUDIO CONT button for **2 seconds or more**.

1	POWER button
2	AUDIO CONT button

### Caution

- Before clearing the DTCs, be sure to enter all of them displayed in the on-board diagnostic test mode on the Audio Exchange Order Form.

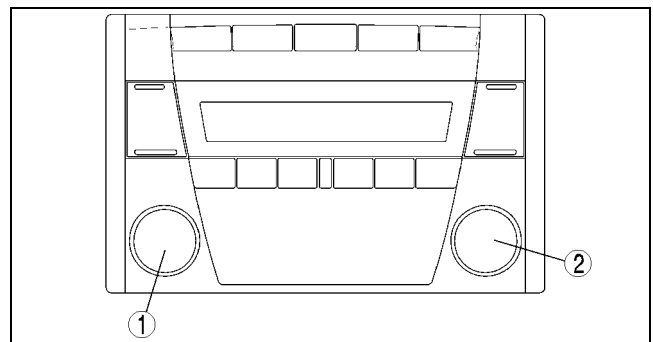

YLE8175W004

- To stop the on-board diagnostic test mode, turn the ignition switch to the LOCK position.

# ON-BOARD DIAGNOSTIC [AUDIO]

## DTC TABLE

A3U090266900W04

Screen display		Malfunction location	Page
DTC	Output signal		
09:Er22	—	Base unit (peripheral circuit)	(See 09-02B-3 DTC 09:ER22)
09:Er20	—	Power supply circuit of base unit	(See 09-02B-4 DTC 09:ER20)
00:Er10	—	Cassette deck—base unit communication line	(See 09-02B-5 DTC 00:ER10)
03:Er10	—	CD player—base unit communication line	(See 09-02B-5 DTC 03:ER10)
05:Er10	—	CD changer (external type)—base unit communication line	(See 09-02B-6 DTC 05:ER10)
06:Er10	—	CD changer (upper module)—base unit communication line	(See 09-02B-6 DTC 06:ER10)
07:Er10	—	MD player—base unit communication line	(See 09-02B-7 DTC 07:ER10)
03:Er01	—	CD player	(See 09-02B-7 DTC 03:ER01)
03:Er02	CHECK*1 CD*2	CD player	(See 09-02B-8 DTC 03:ER02)
03:Er07	CHECK*1 CD*2	CD player	(See 09-02B-8 DTC 03:ER07)
00:Er01	—	Cassette deck	(See 09-02B-9 DTC 00:ER01)
00:Er03	—	Cassette deck	(See 09-02B-9 DTC 00:ER03)
00:Er04	CHECK*1 TAPE*2	Cassette tape	(See 09-02B-9 DTC 00:ER04)
05:Er01	—	CD changer (external type)	(See 09-02B-10 DTC 05:ER01)
05:Er07	CHECK*1 CD*2	CD changer (external type)	(See 09-02B-10 DTC 05:ER07)
06:Er01	—	CD changer (upper module)	(See 09-02B-11 DTC 06:ER01)
06:Er02	CHECK*1 CD*2	CD changer (upper module)	(See 09-02B-11 DTC 06:ER02)
06:Er07	CHECK*1 CD*2	CD changer (upper module)	(See 09-02B-12 DTC 06:ER07)
07:Er01	—	MD player	(See 09-02B-12 DTC 07:ER01)
07:Er02	CHECK*1 MD*2	MD player	(See 09-02B-13 DTC 07:ER02)
07:Er07	CHECK*1 MD*2	MD player	(See 09-02B-13 DTC 07:ER07)
no Err	—	No stored DTCs	—

\*1,\*2: When an error occurs, the error messages are displayed three times in the order of \*1 and \*2, respectively.

## DTC 09:ER22

A3U090266900W05

<b>DTC 09:Er22</b>	Base unit (peripheral circuit)
<b>DETECTION CONDITION</b>	<ul style="list-style-type: none"> <li>Base unit detects malfunction in its inner circuit (related to tuner).</li> </ul>
<b>POSSIBLE CAUSE</b>	<ul style="list-style-type: none"> <li>Base unit malfunction</li> </ul>

## Diagnostic procedure

INSPECTION		ACTION
<b>INSPECT BASE UNIT</b> <ul style="list-style-type: none"> <li>Clear DTC.</li> <li>Turn on radio and operate it for <b>3 seconds or more</b>.</li> <li>Start on-board diagnostic test mode.</li> <li>Is DTC 09:Er22 displayed?</li> </ul>	Yes	Replace base unit.
	No	Troubleshooting completed.

09-02B

# ON-BOARD DIAGNOSTIC [AUDIO]

**DTC 09:Er20**

A3U090266900W06

<b>DTC 09:Er20</b>	Power supply circuit of base unit
<b>DETECTION CONDITION</b>	<ul style="list-style-type: none"> <li>Voltage detected at base unit terminals 1B and 1R is <b>less than 8.5 V, or more than 16 V (must not be 16V)</b>.</li> </ul>
<b>POSSIBLE CAUSE</b>	<ul style="list-style-type: none"> <li>Weak battery</li> <li>Malfunction in wiring harness between battery and base unit</li> </ul>

FUSE BLOCK CONNECTOR  
(JB-01)

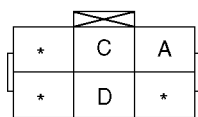

HARNESS SIDE CONNECTOR  
(VIEW FROM HARNESS SIDE)

BASE UNIT CONNECTOR

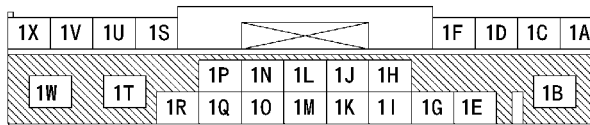

HARNESS SIDE CONNECTOR  
(VIEW FROM HARNESS SIDE)

## Diagnostic procedure

STEP	INSPECTION	ACTION
1	<b>INSPECT BATTERY</b> <ul style="list-style-type: none"> <li>Turn headlights ON then OFF to remove surface charge.</li> <li>Measure battery voltage.</li> <li>Is voltage less than <b>8.5 V</b>?</li> </ul>	Yes Battery is weak. <ul style="list-style-type: none"> <li>Inspect charge/discharge system.</li> </ul>
		No Go to next step.
2	<b>INSPECT BATTERY</b> <ul style="list-style-type: none"> <li>Engine running.</li> <li>Measure battery voltage.</li> <li>Is voltage greater than <b>16 V</b>?</li> </ul>	Yes Battery is overcharging. <ul style="list-style-type: none"> <li>Inspect charge/discharge system.</li> </ul>
		No Go to next step.
3	<b>INSPECT WIRING HARNESS BETWEEN BATTERY AND FUSE BLOCK</b> <ul style="list-style-type: none"> <li>Measure voltage at fuse block connector (JB-01) terminals A and D.</li> <li>Is voltage <b>8.5 V —16 V</b>?</li> </ul>	Yes Go to next step.
		No Repair wiring harness between battery and fuse block.
4	<b>INSPECT WIRING HARNESS BETWEEN FUSE BLOCK AND BASE UNIT</b> <ul style="list-style-type: none"> <li>Measure voltage at base unit connector terminals 1B and 1R.</li> <li>Is voltage <b>8.5 V —16 V</b>?</li> </ul>	Yes Go to next step.
		No Repair wiring harness between fuse block and base unit.
5	<b>INSPECT BASE UNIT</b> <ul style="list-style-type: none"> <li>Clear DTC.</li> <li>Turn ignition switch to ACC or ON position and hold for <b>30 seconds or more</b>.</li> <li>Start on-board diagnostic test mode.</li> <li>Is DTC 09:Er20 displayed?</li> </ul>	Yes Replace base unit.
		No Troubleshooting completed.

## ON-BOARD DIAGNOSTIC [AUDIO]

### DTC 00:Er10

A3U090266900W07

<b>DTC 00:Er10</b>	Cassette deck—base unit communication line
<b>DETECTION CONDITION</b>	<ul style="list-style-type: none"> <li>• Base unit detects communication error with cassette deck (lower module).</li> </ul>
<b>POSSIBLE CAUSE</b>	<ul style="list-style-type: none"> <li>• Malfunction of connectors between base unit and cassette deck (lower module)</li> <li>• Cassette deck (lower module) malfunction</li> <li>• Base unit malfunction</li> </ul>

#### Diagnostic procedure

STEP	INSPECTION	ACTION
1	<b>INSPECT CONNECTOR</b> <ul style="list-style-type: none"> <li>• Remove cassette deck (lower module) and inspect connector for the following.                             <ul style="list-style-type: none"> <li>— Deformation of pin</li> <li>— Poor connection of female terminal</li> <li>— Pinching of foreign material</li> </ul> </li> <li>• Is connector okay?</li> </ul>	Yes Go to next step.
		No Repair connector, then go to next step.
2	<b>VERIFY THAT CASSETTE DECK (LOWER MODULE) IS INSTALLED WITH BASE UNIT</b> <ul style="list-style-type: none"> <li>• Install cassette deck (lower module) and verify its installation condition.</li> <li>• Is cassette deck securely installed?</li> </ul>	Yes Go to next step.
		No Securely install cassette deck (lower module), then go to next step.
3	<b>INSPECT CASSETTE DECK (LOWER MODULE)</b> <ul style="list-style-type: none"> <li>• Clear DTC.</li> <li>• Turn ignition switch to ACC or ON position and hold for <b>3 seconds or more</b>.</li> <li>• Start on-board diagnostic test mode.</li> <li>• Is DTC 00:Er10 displayed?</li> </ul>	Yes Replace base unit and cassette deck (lower module).
		No Troubleshooting completed.

09-02B

### DTC 03:Er10

A3U090266900W08

<b>DTC 03:Er10</b>	CD player—base unit communication line
<b>DETECTION CONDITION</b>	<ul style="list-style-type: none"> <li>• Base unit detects communication error with CD player (upper module).</li> </ul>
<b>POSSIBLE CAUSE</b>	<ul style="list-style-type: none"> <li>• Malfunction of connectors between base unit and CD player (upper module)</li> <li>• CD player (upper module) malfunction</li> <li>• Base unit malfunction</li> </ul>

#### Diagnostic procedure

STEP	INSPECTION	ACTION
1	<b>INSPECT CONNECTOR</b> <ul style="list-style-type: none"> <li>• Remove CD player (upper module) and inspect connector for the following.                             <ul style="list-style-type: none"> <li>— Deformation of pin</li> <li>— Poor connection of female terminal</li> <li>— Pinching of foreign material</li> </ul> </li> <li>• Is connector okay?</li> </ul>	Yes Go to next step.
		No Repair connector, then go to next step.
2	<b>VERIFY THAT CD PLAYER (UPPER MODULE) IS INSTALLED WITH BASE UNIT</b> <ul style="list-style-type: none"> <li>• Install CD player (upper module) and verify its installation condition.</li> <li>• Is CD player securely installed?</li> </ul>	Yes Go to next step.
		No Securely install CD player (upper module), then go to next step.
3	<b>INSPECT CD PLAYER (UPPER MODULE)</b> <ul style="list-style-type: none"> <li>• Clear DTC.</li> <li>• Turn ignition switch to ACC or ON position and wait for <b>3 seconds or more</b>.</li> <li>• Start on-board diagnostic test mode.</li> <li>• Is DTC 03:Er10 displayed?</li> </ul>	Yes Replace base unit and CD player (upper module).
		No Troubleshooting completed.

## ON-BOARD DIAGNOSTIC [AUDIO]

### DTC 05:ER10

A3U090266900W09

<b>DTC 05:Er10</b>	CD changer—base unit communication line
<b>DETECTION CONDITION</b>	<ul style="list-style-type: none"> <li>Base unit detects communication error with CD changer (external type)</li> </ul>
<b>POSSIBLE CAUSE</b>	<ul style="list-style-type: none"> <li>Malfunction of connectors between base unit and CD changer (external type)</li> <li>CD changer (external type) malfunction</li> <li>Base unit malfunction</li> </ul>

#### Diagnostic procedure

STEP	INSPECTION		ACTION
1	<b>INSPECT CONNECTOR</b> <ul style="list-style-type: none"> <li>Inspect base unit and CD changer (external type) connectors for connection.</li> <li>Are connectors securely connected?</li> </ul>	Yes	Go to next step.
		No	Reconnect connector, then go to next step.
2	<b>INSPECT WIRING HARNESS BETWEEN CD CHANGER (EXTERNAL TYPE) AND BASE UNIT</b> <ul style="list-style-type: none"> <li>Inspect wiring harness between base unit and CD changer (external type).</li> <li>Is wiring harness okay?</li> </ul>	Yes	Go to next step.
		No	Securely install CD changer (external type), then go to next step.
3	<b>INSPECT CD CHANGER (EXTERNAL TYPE)</b> <ul style="list-style-type: none"> <li>Clear DTC.</li> <li>Turn ignition switch to ACC or ON position and wait for <b>3 seconds or more</b>.</li> <li>Start on-board diagnostic test mode.</li> <li>Is DTC 05:Er10 displayed?</li> </ul>	Yes	Replace base unit and CD changer (external type).
		No	Troubleshooting completed.

### DTC 06:ER10

A3U090266900W10

<b>DTC 06:Er10</b>	CD changer—base unit communication line
<b>DETECTION CONDITION</b>	<ul style="list-style-type: none"> <li>Base unit detects communication error with CD changer (upper module)</li> </ul>
<b>POSSIBLE CAUSE</b>	<ul style="list-style-type: none"> <li>Malfunction of connectors between base unit and CD changer (upper module)</li> <li>CD changer (upper module) malfunction</li> <li>Base unit malfunction</li> </ul>

#### Diagnostic procedure

STEP	INSPECTION		ACTION
1	<b>INSPECT CONNECTOR</b> <ul style="list-style-type: none"> <li>Remove CD changer (upper module) and inspect connector for the following.                             <ul style="list-style-type: none"> <li>Deformation of pin</li> <li>Poor connection of female terminal</li> <li>Pinching of foreign material</li> </ul> </li> <li>Is connector okay?</li> </ul>	Yes	Go to next step.
		No	Repair connector, then go to next step.
2	<b>VERIFY THAT CD CHANGER (UPPER MODULE) IS INSTALLED WITH BASE UNIT</b> <ul style="list-style-type: none"> <li>Install CD changer (upper module) and verify its installation condition.</li> <li>Is CD changer (upper module) securely installed?</li> </ul>	Yes	Go to next step.
		No	Securely install CD changer (upper module), then go to next step.
3	<b>INSPECT CD CHANGER (UPPER MODULE)</b> <ul style="list-style-type: none"> <li>Clear DTC.</li> <li>Turn ignition switch to ACC or ON position and wait for <b>3 seconds or more</b>.</li> <li>Start on-board diagnostic test mode.</li> <li>Is DTC 06:Er10 displayed?</li> </ul>	Yes	Replace base unit and CD changer (upper module).
		No	Troubleshooting completed.



## ON-BOARD DIAGNOSTIC [AUDIO]

### DTC 07:Er10

A3U090266900W11

<b>DTC 07:Er10</b>	MD player—base unit communication line
<b>DETECTION CONDITION</b>	<ul style="list-style-type: none"> <li>• Base unit detects communication error with MD player (lower module)</li> </ul>
<b>POSSIBLE CAUSE</b>	<ul style="list-style-type: none"> <li>• Malfunction of connectors between base unit and MD player (lower module)</li> <li>• MD player (lower module) malfunction</li> <li>• Base unit malfunction</li> </ul>

#### Diagnostic procedure

STEP	INSPECTION	ACTION	
1	<b>INSPECT CONNECTOR</b> <ul style="list-style-type: none"> <li>• Remove MD player (lower module) and inspect connector for the following.                             <ul style="list-style-type: none"> <li>— Deformation of pin</li> <li>— Poor connection of female terminal</li> <li>— Pinching of foreign material</li> </ul> </li> <li>• Is connector okay?</li> </ul>	Yes	Go to next step.
		No	Repair connector, then go to next step.
2	<b>VERIFY THAT MD PLAYER (LOWER MODULE) IS INSTALLED WITH BASE UNIT</b> <ul style="list-style-type: none"> <li>• Install MD player (lower module) and verify its installation condition.</li> <li>• Is MD player (lower module) securely installed?</li> </ul>	Yes	Go to next step.
		No	Securely install MD player (lower module), then go to next step.
3	<b>INSPECT MD PLAYER (LOWER MODULE)</b> <ul style="list-style-type: none"> <li>• Clear DTC.</li> <li>• Turn ignition switch to ACC or ON position and wait for <b>3 seconds or more</b>.</li> <li>• Start on-board diagnostic test mode.</li> <li>• Is DTC 07:Er10 displayed?</li> </ul>	Yes	Replace base unit and MD player (lower module).
		No	Troubleshooting completed.

09-02B

### DTC 03:Er01

A3U090266900W12

<b>DTC 03:Er01</b>	CD player (upper module)
<b>DETECTION CONDITION</b>	<ul style="list-style-type: none"> <li>• CD player (upper module) cannot perform insert and eject commands.</li> </ul>
<b>POSSIBLE CAUSE</b>	<ul style="list-style-type: none"> <li>• Defective CD (broken or foreign material stuck/attached)</li> <li>• CD player (upper module) malfunction</li> </ul>

#### Diagnostic procedure

STEP	INSPECTION	ACTION	
1	<ul style="list-style-type: none"> <li>• Is CD able to be ejected?</li> </ul>	Yes	Go to next step.
		No	Replace CD player (upper module).
2	<b>INSPECT CD</b> <ul style="list-style-type: none"> <li>• Inspect condition of CD where error has occurred.</li> <li>• Is CD okay?</li> </ul> <p><b>Note</b></p> <ul style="list-style-type: none"> <li>• In some cases, not all CD-R/CD-RW will play.</li> </ul>	Yes	Go to next step.
		No	Repair (remove foreign material) or replace CD, then go to next step.
3	<b>INSPECT CD PLAYER (UPPER MODULE)</b> <ul style="list-style-type: none"> <li>• Clear DTC.</li> <li>• Insert and eject CD with no defect.</li> <li>• Start on-board diagnostic test mode.</li> <li>• Is DTC 03:Er01 displayed?</li> </ul>	Yes	Replace CD player (upper module).
		No	Troubleshooting completed.

## ON-BOARD DIAGNOSTIC [AUDIO]

### DTC 03:ER02

A3U090266900W13

<b>DTC 03:Er02</b>	CD player (upper module)
<b>DETECTION CONDITION</b>	<p><b>Note</b></p> <ul style="list-style-type: none"> <li>When error occurs, error message "CHECK CD" is displayed in the LCD.</li> <li>Cannot play CD normally or change tracks.</li> </ul>
<b>POSSIBLE CAUSE</b>	<ul style="list-style-type: none"> <li>Defective CD (scratches or dirt)</li> <li>CD player (upper module) malfunction</li> </ul>

#### Diagnostic procedure

STEP	INSPECTION	ACTION		
1	<b>VERIFY WHETHER MALFUNCTION IS IN CD PLAYER (UPPER MODULE) OR CD</b> <ul style="list-style-type: none"> <li>Play CD and select other song (change tracks).</li> <li>Does CD player change tracks?</li> </ul>	Yes	Go to Step 3.	
		No	Not able to change particular tracks.	Go to next step.
			Not able to change any tracks.	Change CD and perform tracks-change again. <ul style="list-style-type: none"> <li>If CD player changes tracks, then go to Step 3.</li> <li>If not, replace CD player (upper module).</li> </ul>
2	<b>INSPECT CD</b> <ul style="list-style-type: none"> <li>Inspect condition of CD where error has occurred.</li> <li>Is CD okay?</li> </ul> <p><b>Note</b></p> <ul style="list-style-type: none"> <li>In some cases, not all CD-R/CD-RW will play.</li> </ul>	Yes	Go to next step.	
		No	Repair (remove foreign material) or replace CD, then go to next step.	
3	<b>INSPECT CD PLAYER (UPPER MODULE)</b> <ul style="list-style-type: none"> <li>Clear DTC.</li> <li>Play CD and select other song (change tracks).</li> <li>Start on-board diagnostic test mode.</li> <li>Is DTC 03:Er02 displayed?</li> </ul>	Yes	Replace CD player (upper module).	
		No	Troubleshooting completed.	

### DTC 03:ER07

A3U090266900W14

<b>DTC 03:Er07</b>	CD player (upper module)
<b>DETECTION CONDITION</b>	<p><b>Note</b></p> <ul style="list-style-type: none"> <li>When error occurs, error message "CHECK CD" is displayed in the LCD.</li> <li>Base unit detects CD reading error.</li> </ul>
<b>POSSIBLE CAUSE</b>	<ul style="list-style-type: none"> <li>Defective CD (scratches or dirt)</li> <li>CD player (upper module) malfunction</li> </ul>

#### Diagnostic procedure

STEP	INSPECTION	ACTION	
1	<b>INSPECT CD</b> <ul style="list-style-type: none"> <li>Inspect condition of CD where error has occurred.</li> <li>Is CD okay?</li> </ul> <p><b>Note</b></p> <ul style="list-style-type: none"> <li>In some cases, not all CD-R/CD-RW will play.</li> </ul>	Yes	Go to next step.
		No	Repair (remove foreign material) or replace CD, then go to next step.
2	<b>INSPECT CD PLAYER (UPPER MODULE)</b> <ul style="list-style-type: none"> <li>Clear DTC.</li> <li>Insert and play CD with no defect.</li> <li>Start on-board diagnostic test mode.</li> <li>Is DTC 03:Er07 displayed?</li> </ul>	Yes	Replace CD player (upper module).
		No	Troubleshooting completed.

## ON-BOARD DIAGNOSTIC [AUDIO]

### DTC 00:Er01

A3U090266900W15

<b>DTC 00:Er01</b>	Cassette deck (lower module)
<b>DETECTION CONDITION</b>	<ul style="list-style-type: none"> <li>Cassette deck (lower module) cannot perform insert and eject commands.</li> </ul>
<b>POSSIBLE CAUSE</b>	<ul style="list-style-type: none"> <li>Defective cassette tape (deformation, broken, or foreign material stuck/attached)</li> <li>Cassette deck (lower module) malfunction</li> </ul>

#### Diagnostic procedure

STEP	INSPECTION	ACTION	
1	<ul style="list-style-type: none"> <li>Is cassette tape able to be ejected?</li> </ul>	Yes	Go to next step.
		No	Replace cassette deck (lower module).
2	<b>INSPECT CASSETTE TAPE</b> <ul style="list-style-type: none"> <li>Inspect condition of cassette tape where error has occurred.</li> <li>Is cassette tape okay?</li> </ul>	Yes	Go to next step.
		No	Repair (remove foreign material) or replace cassette tape, then go to next step.
3	<b>INSPECT CASSETTE DECK (LOWER MODULE)</b> <ul style="list-style-type: none"> <li>Clear DTC.</li> <li>Insert and eject cassette tape with no defect.</li> <li>Start on-board diagnostic test mode.</li> <li>Is DTC 00:Er01 displayed?</li> </ul>	Yes	Replace cassette deck (lower module).
		No	Troubleshooting completed.

### DTC 00:Er03

A3U090266900W16

<b>DTC 00:Er03</b>	Cassette deck (lower module)
<b>DETECTION CONDITION</b>	<ul style="list-style-type: none"> <li>Base unit detects that reel built into cassette deck does not operate.</li> </ul>
<b>POSSIBLE CAUSE</b>	<ul style="list-style-type: none"> <li>Defective cassette tape (tape slack, pinched tape in internal cassette deck)</li> <li>Cassette deck (lower module) malfunction</li> </ul>

#### Diagnostic procedure

STEP	INSPECTION	ACTION	
1	<b>INSPECT CASSETTE TAPE</b> <ul style="list-style-type: none"> <li>Inspect condition of cassette tape where error has occurred.</li> <li>Is cassette tape okay?</li> </ul>	Yes	Go to next step.
		No	Repair (remove tape slack or repair pinched tape) or replace cassette tape, then go to next step.
2	<b>INSPECT CASSETTE DECK (LOWER MODULE)</b> <ul style="list-style-type: none"> <li>Clear DTC.</li> <li>Insert cassette tape with no defect.</li> <li>Play cassette tape for <b>20 seconds or more</b>.</li> <li>Start on-board diagnostic test mode.</li> <li>Is DTC 00:Er03 displayed?</li> </ul>	Yes	Replace cassette deck (lower module).
		No	Troubleshooting completed.

### DTC 00:Er04

A3U090266900W17

<b>DTC 00:Er04</b>	Cassette tape
<b>DETECTION CONDITION</b>	<p><b>Note</b></p> <ul style="list-style-type: none"> <li>When error occurs, error message "CHECK TAPE" is displayed in the LCD.</li> </ul> <ul style="list-style-type: none"> <li>Cassette tape is worn out.</li> </ul>
<b>POSSIBLE CAUSE</b>	<ul style="list-style-type: none"> <li>Tape wear</li> <li>Cassette deck (lower module) malfunction</li> </ul>

#### Diagnostic procedure

STEP	INSPECTION	ACTION	
1	<b>INSPECT CASSETTE TAPE</b> <ul style="list-style-type: none"> <li>Inspect condition of cassette tape where error has occurred.</li> <li>Is cassette tape okay?</li> </ul>	Yes	Go to next step.
		No	Replace cassette tape, then go to next step.
2	<b>INSPECT CASSETTE DECK (LOWER MODULE)</b> <ul style="list-style-type: none"> <li>Clear DTC.</li> <li>Insert cassette tape with no defect.</li> <li>Play cassette tape for <b>20 seconds or more</b>.</li> <li>Start on-board diagnostic test mode.</li> <li>Is DTC 00:Er04 displayed?</li> </ul>	Yes	Replace cassette deck (lower module).
		No	Troubleshooting completed.

## ON-BOARD DIAGNOSTIC [AUDIO]

### DTC 05:ER01

A3U090266900W18

<b>DTC 05:Er01</b>	CD changer (external type)
<b>DETECTION CONDITION</b>	<ul style="list-style-type: none"> <li>Changer function does not operate.</li> </ul>
<b>POSSIBLE CAUSE</b>	<ul style="list-style-type: none"> <li>Defective CD (broken or foreign material)</li> <li>Magazine malfunction</li> <li>CD changer (external type) malfunction</li> </ul>

#### Diagnostic procedure

STEP	INSPECTION	ACTION	
1	<b>VERIFY WHETHER MALFUNCTION IS IN CD CHANGER OR OTHER PARTS</b> <ul style="list-style-type: none"> <li>Operate changer function.</li> <li>Is function okay?</li> </ul>	Yes	Go to Step 4.
		No	Not able to change particular CD.
	Not able to change any CD.		Go to Step 3.
2	<b>INSPECT CD</b> <ul style="list-style-type: none"> <li>Inspect condition of CD where error has occurred.</li> <li>Is CD okay?</li> </ul> <p><b>Note</b></p> <ul style="list-style-type: none"> <li>In some cases, not all CD-R/CD-RW will play.</li> </ul>	Yes	Go to next step.
		No	Repair (remove foreign material) or replace CD, then go to next step.
3	<b>INSPECT MAGAZINE</b> <ul style="list-style-type: none"> <li>Inspect magazine.</li> <li>Is magazine okay?</li> </ul>	Yes	Go to next step.
		No	Repair or replace magazine, then go to next step.
4	<b>INSPECT CD CHANGER (EXTERNAL TYPE)</b> <ul style="list-style-type: none"> <li>Clear DTC.</li> <li>Operate changer.</li> <li>Start on-board diagnostic test mode.</li> <li>Is DTC 05:Er01 displayed?</li> </ul>	Yes	Replace CD changer (external type).
		No	Troubleshooting completed.

### DTC 05:ER07

A3U090266900W19

<b>DTC 05:Er07</b>	CD changer (external type)
<b>DETECTION CONDITION</b>	<p><b>Note</b></p> <ul style="list-style-type: none"> <li>When error occurs, error message "CHECK CD" is displayed in the LCD.</li> <li>Base unit detects CD reading error.</li> </ul>
<b>POSSIBLE CAUSE</b>	<ul style="list-style-type: none"> <li>Defective CD (scratches or dirt)</li> <li>CD changer (external type) malfunction</li> </ul>

#### Diagnostic procedure

STEP	INSPECTION	ACTION	
1	<b>VERIFY WHETHER MALFUNCTION IS IN CD CHANGER OR OTHER PARTS</b> <ul style="list-style-type: none"> <li>Play all CD in magazine.</li> <li>Is CD changer able to read them properly?</li> </ul>	Yes	Go to Step 3.
		No	Not able to change particular CD.
	Not able to change any CD.		Go to Step 3.
2	<b>INSPECT CD</b> <ul style="list-style-type: none"> <li>Inspect condition of CD where error has occurred.</li> <li>Is CD okay?</li> </ul> <p><b>Note</b></p> <ul style="list-style-type: none"> <li>In some cases, not all CD-R/CD-RW will play.</li> </ul>	Yes	Go to next step.
		No	Repair (remove foreign material) or replace CD, then go to next step.
3	<b>INSPECT CD CHANGER (EXTERNAL TYPE)</b> <ul style="list-style-type: none"> <li>Clear DTC.</li> <li>Insert and play CD with no defect.</li> <li>Start on-board diagnostic test mode.</li> <li>Is DTC 05:Er07 displayed?</li> </ul>	Yes	Replace CD changer (external type).
		No	Troubleshooting completed.

## ON-BOARD DIAGNOSTIC [AUDIO]

### DTC 06:ER01

A3U090266900W20

<b>DTC 06:Er01</b>	CD changer (upper module)
<b>DETECTION CONDITION</b>	<ul style="list-style-type: none"> <li>CD changer (upper module) cannot perform insert, eject, and disc change commands.</li> </ul>
<b>POSSIBLE CAUSE</b>	<ul style="list-style-type: none"> <li>Defective CD (broken or foreign material stuck/attached)</li> <li>CD changer (upper module) malfunction</li> </ul>

#### Diagnostic procedure

STEP	INSPECTION	ACTION	
1	<ul style="list-style-type: none"> <li>Is CD able to be ejected?</li> </ul>	Yes	Go to next step.
		No	Replace CD changer (upper module).
2	<b>INSPECT CD</b> <ul style="list-style-type: none"> <li>Inspect condition of CD where error has occurred.</li> <li>Is CD okay?</li> </ul> <p><b>Note</b></p> <ul style="list-style-type: none"> <li>In some cases, not all CD-R/CD-RW will play.</li> </ul>	Yes	Go to next step.
		No	Repair (remove foreign material) or replace CD, then go to next step.
3	<b>INSPECT CD CHANGER (UPPER MODULE)</b> <ul style="list-style-type: none"> <li>Clear DTC.</li> <li>Insert and eject CD with no defect.</li> <li>Start on-board diagnostic test mode.</li> <li>Is DTC 06:Er01 displayed?</li> </ul>	Yes	Replace CD changer (upper module).
		No	Troubleshooting completed.

### DTC 06:ER02

A3U090266900W21

<b>DTC 06:Er02</b>	CD changer (upper module)
<b>DETECTION CONDITION</b>	<p><b>Note</b></p> <ul style="list-style-type: none"> <li>When error occurs, error message "CHECK CD" is displayed in the LCD.</li> </ul> <ul style="list-style-type: none"> <li>Can not play CD normally or change tracks.</li> </ul>
<b>POSSIBLE CAUSE</b>	<ul style="list-style-type: none"> <li>Defective CD (scratches or dirt)</li> <li>CD changer (upper module) malfunction</li> </ul>

#### Diagnostic procedure

STEP	INSPECTION	ACTION		
1	<b>VERIFY WHETHER MALFUNCTION IS IN CD CHANGER (UPPER MODULE) OR CD</b> <ul style="list-style-type: none"> <li>Play all CDs in changer and select other song (change tracks).</li> <li>Is CD changer able to change tracks?</li> </ul>	Yes	Go to Step 3.	
		No	Not able to change particular tracks.	Go to next step.
		No	Not able to change any tracks.	Change CD and perform tracks-change again. <ul style="list-style-type: none"> <li>If CD changer changes tracks, then go to Step 3.</li> <li>If not, replace CD changer (upper module).</li> </ul>
2	<b>INSPECT CD</b> <ul style="list-style-type: none"> <li>Inspect condition of CD where error has occurred.</li> <li>Is CD okay?</li> </ul> <p><b>Note</b></p> <ul style="list-style-type: none"> <li>In some cases, not all CD-R/CD-RW will play.</li> </ul>	Yes	Go to next step.	
		No	Repair (remove foreign material) or replace CD, then go to next step.	
3	<b>INSPECT CD CHANGER (UPPER MODULE)</b> <ul style="list-style-type: none"> <li>Clear DTC.</li> <li>Play CD and select other song (change tracks).</li> <li>Start on-board diagnostic test mode.</li> <li>Is DTC 06:Er02 displayed?</li> </ul>	Yes	Replace CD changer (upper module).	
		No	Troubleshooting completed.	

09-02B

## ON-BOARD DIAGNOSTIC [AUDIO]

### DTC 06:Er07

A3U090266900W22

<b>DTC 06:Er07</b>	CD changer (upper module)
<b>DETECTION CONDITION</b>	<p><b>Note</b></p> <ul style="list-style-type: none"> <li>When error occurs, error message "CHECK CD" is displayed in the LCD.</li> <li>Base unit detects CD reading error.</li> </ul>
<b>POSSIBLE CAUSE</b>	<ul style="list-style-type: none"> <li>Defective CD (scratches or dirt)</li> <li>CD changer (upper module) malfunction</li> </ul>

#### Diagnostic procedure

STEP	INSPECTION	ACTION		
1	<b>VERIFY WHETHER MALFUNCTION IS IN CD CHANGER (UPPER MODULE) OR CD</b> <ul style="list-style-type: none"> <li>Play all CDs in changer.</li> <li>Is CD changer able to read them properly?</li> </ul>	Yes	Go to Step 3.	
		No	Not able to read particular CD.	Go to next step.
			Not able to read any CD.	Go to Step 3.
2	<b>INSPECT CD</b> <ul style="list-style-type: none"> <li>Inspect condition of CD where error has occurred.</li> <li>Is CD okay?</li> </ul> <p><b>Note</b></p> <ul style="list-style-type: none"> <li>In some cases, not all CD-R/CD-RW will play.</li> </ul>	Yes	Go to next step.	
		No	Repair (remove foreign material) or replace CD, then go to next step.	
3	<b>INSPECT CD CHANGER (UPPER MODULE)</b> <ul style="list-style-type: none"> <li>Clear DTC.</li> <li>Insert and play CD for <b>12 seconds or more</b>.</li> <li>Start on-board diagnostic test mode.</li> <li>Is DTC 06:Er07 displayed?</li> </ul>	Yes	Replace CD changer (upper module).	
		No	Troubleshooting completed.	

### DTC 07:Er01

A3U090266900W23

<b>DTC 07:Er01</b>	MD player (lower module)
<b>DETECTION CONDITION</b>	<ul style="list-style-type: none"> <li>MD player (lower module) cannot perform insert and eject commands.</li> </ul>
<b>POSSIBLE CAUSE</b>	<ul style="list-style-type: none"> <li>Defective MD (broken or foreign material stuck/attached)</li> <li>MD player (lower module) malfunction</li> </ul>

#### Diagnostic procedure

STEP	INSPECTION	ACTION	
1	<ul style="list-style-type: none"> <li>Is MD able to be ejected?</li> </ul>	Yes	Go to next step.
		No	Replace MD player (lower module).
2	<b>INSPECT MD</b> <ul style="list-style-type: none"> <li>Inspect condition of MD where error has occurred.</li> <li>Is MD okay?</li> </ul>	Yes	Go to next step.
		No	Repair (remove foreign material) or replace MD, then go to next step.
3	<b>INSPECT MD PLAYER (LOWER MODULE)</b> <ul style="list-style-type: none"> <li>Clear DTC.</li> <li>Insert and eject MD with no defect.</li> <li>Start on-board diagnostic test mode.</li> <li>Is DTC 07:Er01 displayed?</li> </ul>	Yes	Replace MD player (lower module).
		No	Troubleshooting completed.

## ON-BOARD DIAGNOSTIC [AUDIO]

### DTC 07:ER02

A3U090266900W24

<b>DTC 07:Er02</b>	MD player (lower module)
<b>DETECTION CONDITION</b>	<p><b>Note</b></p> <ul style="list-style-type: none"> <li>When error occurs, error message “CHECK MD” is displayed in the LCD.</li> <li>Can not play MD normally or change tracks.</li> </ul>
<b>POSSIBLE CAUSE</b>	<ul style="list-style-type: none"> <li>Defective MD (scratches or dirt)</li> <li>MD player (lower module) malfunction</li> </ul>

#### Diagnostic procedure

STEP	INSPECTION	ACTION		
1	<b>VERIFY WHETHER MALFUNCTION IS IN MD PLAYER (LOWER MODULE) OR MD</b> <ul style="list-style-type: none"> <li>Play MD and select other song (change tracks).</li> <li>Is MD player able to change tracks?</li> </ul>	Yes	Go to Step 3.	
		No	Not able to change particular tracks.	Go to next step.
			Not able to change any tracks.	Change MD and perform tracks-change again. <ul style="list-style-type: none"> <li>If MD player changes tracks, then go to Step 3.</li> <li>If not, replace MD player (lower module).</li> </ul>
2	<b>INSPECT MD</b> <ul style="list-style-type: none"> <li>Inspect condition of MD where error has occurred.</li> <li>Is MD okay?</li> </ul>	Yes	Go to next step.	
		No	Repair (remove foreign material) or replace MD, then go to next step.	
3	<b>INSPECT MD PLAYER (LOWER MODULE)</b> <ul style="list-style-type: none"> <li>Clear DTC.</li> <li>Play MD and select other song (change tracks).</li> <li>Start on-board diagnostic test mode.</li> <li>Is DTC 07:Er02 displayed?</li> </ul>	Yes	Replace MD player (lower module).	
		No	Troubleshooting completed.	

09-02B

### DTC 07:ER07

A3U090266900W25

<b>DTC 07:Er07</b>	MD player (lower module)
<b>DETECTION CONDITION</b>	<p><b>Note</b></p> <ul style="list-style-type: none"> <li>When error occurs, error message “CHECK MD” is displayed in the LCD.</li> <li>Base unit detects MD reading error.</li> </ul>
<b>POSSIBLE CAUSE</b>	<ul style="list-style-type: none"> <li>Defective MD (scratches or dirt)</li> <li>MD player (lower module) malfunction</li> </ul>

#### Diagnostic procedure

STEP	INSPECTION	ACTION	
1	<b>INSPECT MD</b> <ul style="list-style-type: none"> <li>Inspect condition of MD where error has occurred.</li> <li>Is MD okay?</li> </ul>	Yes	Go to next step.
		No	Repair (remove foreign material) or replace MD, then go to next step.
2	<b>INSPECT MD PLAYER (LOWER MODULE)</b> <ul style="list-style-type: none"> <li>Clear DTC.</li> <li>Insert and play MD for <b>12 seconds or more</b>.</li> <li>Start on-board diagnostic test mode.</li> <li>Is DTC 07:Er07 displayed?</li> </ul>	Yes	Replace MD player (lower module).
		No	Troubleshooting completed.

# ON-BOARD DIAGNOSTIC [AUDIO]

## DIAGNOSTIC ASSIST FUNCTION

A3U090266900W26

### Structural View Switch location

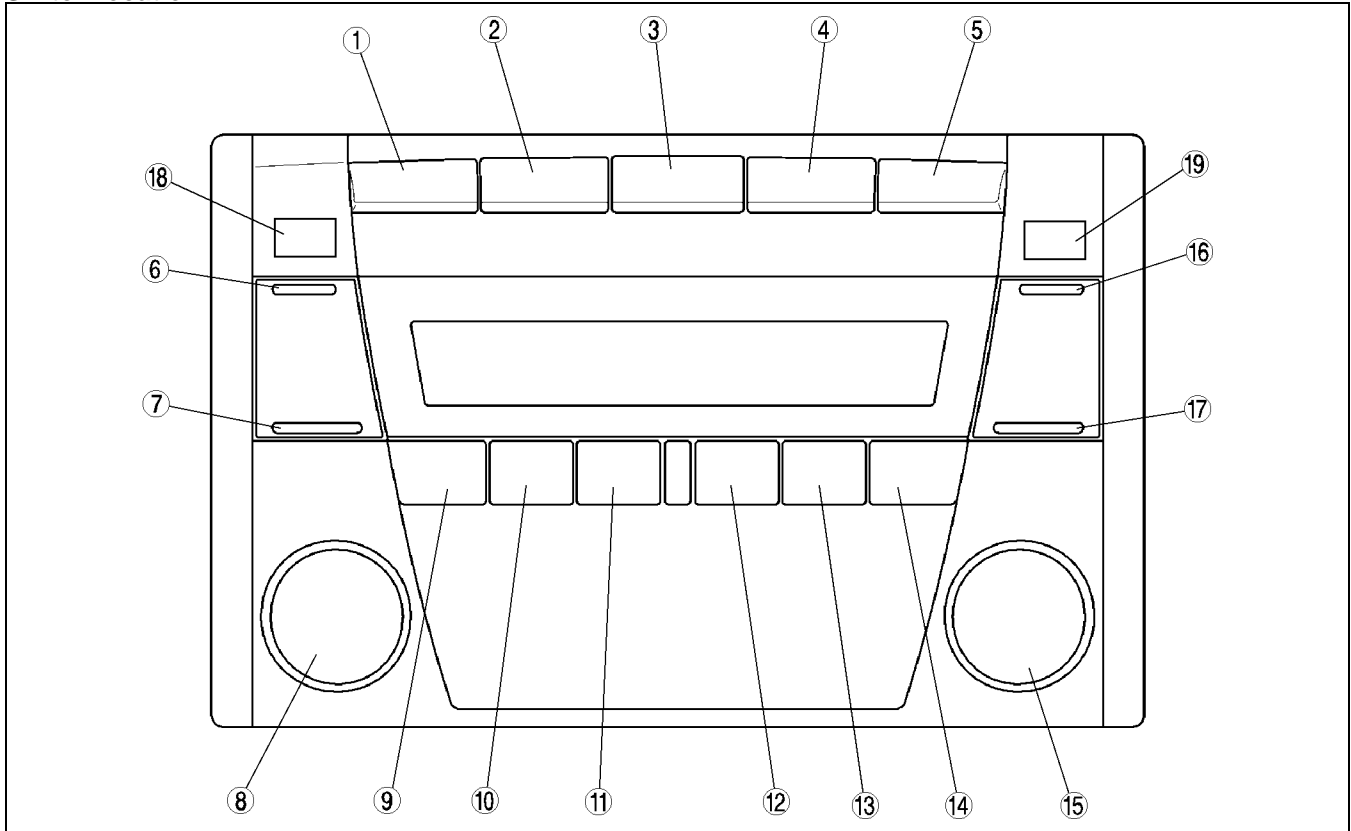

Z3U0920W004

1	FM1/2 button
2	AM button
3	CD button
4	MD/TAPE button
5	CLOCK button
6	SEEK button (upper)
7	SEEK button (lower)
8	POWER/VOL button
9	Preset button "1"
10	Preset button "2"

11	Preset button "3"
12	Preset button "4"
13	Preset button "5"
14	Preset button "6"
15	AUDIO CONT/TURN button
16	SCAN button
17	AUTO-M button
18	LOAD button (CD changer)
19	EJECT button (CD player and CD changer)

### LCD inspection

- With audio on, first press the POWER button and hold it, then press the SEEK button (upper) for **approximately 1 second**.
- Inspect the LCD according to the following table:

Inspection	Display	Action	
Start LCD inspection mode.		Characters displayed in LCD are not truncated or faint.	LCD is okay.
		Other than above.	Replace base unit.

- Turn the audio off or the ignition switch to the LOCK position to stop the diagnostic assist function.



## ON-BOARD DIAGNOSTIC [AUDIO]

### Button inspection

- With audio on, first press the POWER button and hold it, then press the CLOCK button for **approximately 1 second**.
- Inspect the button according to the following table:

#### Note

- The button inspection mode is designed for base unit button. The following lower module button cannot be inspected in this mode. (A buzz will not sound.)
  - Cassete deck: DOLBY button, EJECT button
  - MD player: DISP button, EJECT button

Inspection	Display	Action	
<ul style="list-style-type: none"> <li>Start button inspection mode.</li> <li>Press the all buttons.</li> </ul>	—	Buzzer sounds.	Button is okay.
		Buzzer does not sound.	Replace base unit.

- Turn the audio off or the ignition switch to the LOCK position to stop the diagnostic assist function.

### Speaker inspection

- With audio on, first press the POWER button and hold it, then press the AUTO-M button for **approximately 1 second**.
- Inspect the speaker according to the following table:



Inspection	Display	Action	
<ul style="list-style-type: none"> <li>Start speaker inspection mode.</li> <li>Does each speaker output sound in the following order?                             <ol style="list-style-type: none"> <li>Left front door speaker</li> <li>Right front door speaker</li> <li>Right rear package speaker (4SD) or rear door speaker (5HB)</li> <li>Left rear package speaker (4SD) or rear door speaker (5HB)</li> </ol> </li> </ul>	—	Yes	Speakers and wiring harness between base unit and speakers are okay.
		No	Inspect the following parts. <ul style="list-style-type: none"> <li>Malfunctioning speaker</li> <li>Wiring harness between base unit and malfunctioning speaker</li> </ul>

09-02B

- Turn the audio off or the ignition switch to the LOCK position to stop the diagnostic assist function.

### Radio reception condition inspection

- With audio on and at radio mode, first press the POWER button and hold it, then press the preset button "2" for **approximately 1 second**.
- Inspect the radio reception condition according to the following table:

Inspection	Display	Action
Start radio reception condition inspection mode.	NORMAL  5 GRADUATIONS OR ABOVE	Antenna, antenna feeder, and base unit are okay.
	 3-4 GRADUATIONS	Change frequency (channel) and inspect again.
	MALFUNCTIONING  2 GRADUATIONS OR BELOW	Inspect antenna and antenna feeder. <ul style="list-style-type: none"> <li>If either one of them is not okay, replace malfunctioning part.</li> <li>If both are okay, replace base unit.</li> </ul>

- Turn the audio off or the ignition switch to the LOCK position to stop the diagnostic assist function.

09-03 SYMPTOM TROUBLESHOOTING

KEYLESS ENTRY SYSTEM  
 WIRING DIAGRAM ..... 09-03-1  
 FOREWORD ..... 09-03-1  
 KEYLESS ENTRY SYSTEM  
 CHECK SHEET ..... 09-03-2  
 KEYLESS ENTRY SYSTEM  
 PREINSPECTION ..... 09-03-3

TROUBLESHOOTING INDEX ..... 09-03-3  
 NO.1 ONE OR MORE ON-BOARD DIAGNOSTIC  
 FUNCTIONS INOPERATIVE ..... 09-03-4  
 NO.2 ALL ON-BOARD DIAGNOSTIC  
 FUNCTIONS INOPERATIVE ..... 09-03-6  
 NO.3 TRANSMITTER ID CODE CANNOT  
 BE REPROGRAMMED ..... 09-03-7

KEYLESS ENTRY SYSTEM WIRING DIAGRAM

A3U09036900W01

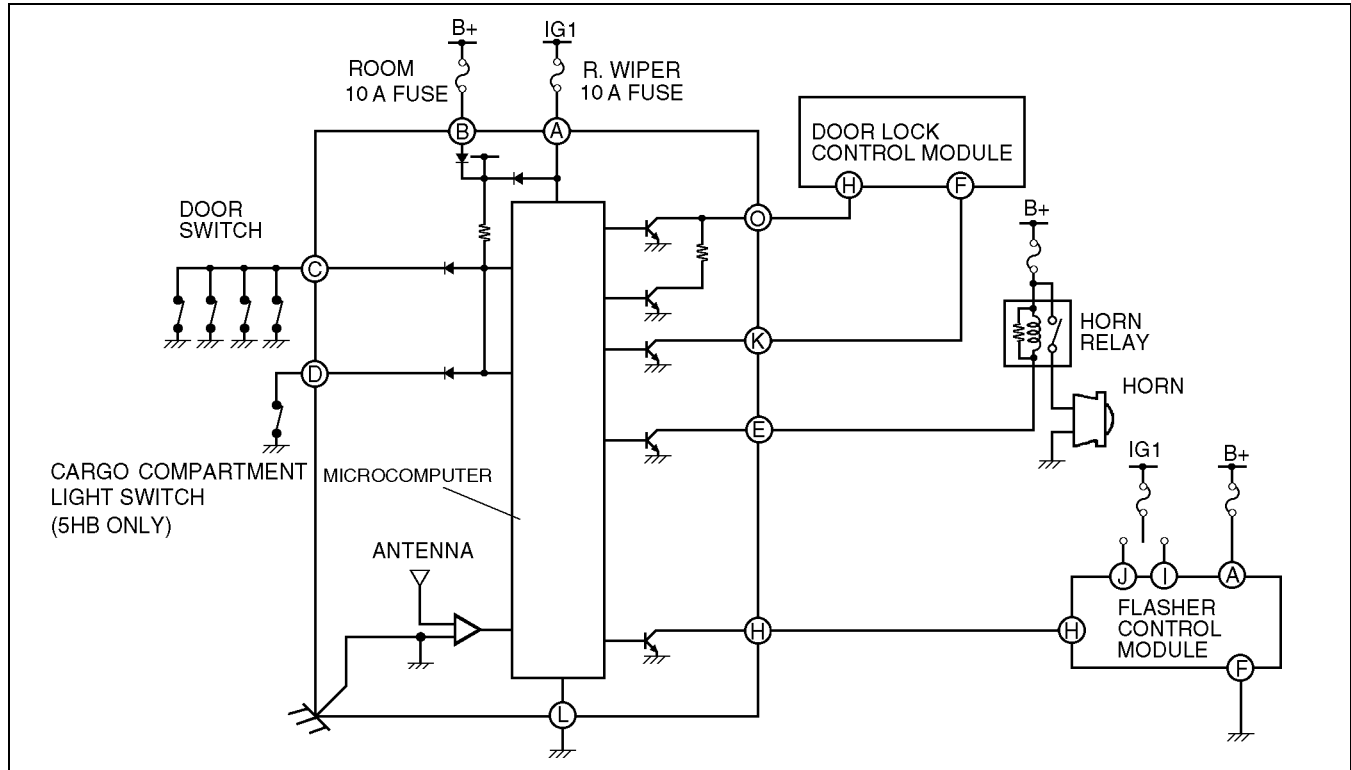

A3U0903W01

09-03

FOREWORD

- Go to symptom troubleshooting after identifying the specific malfunction by performing a keyless entry system preliminary inspection.

A3U09036900W02

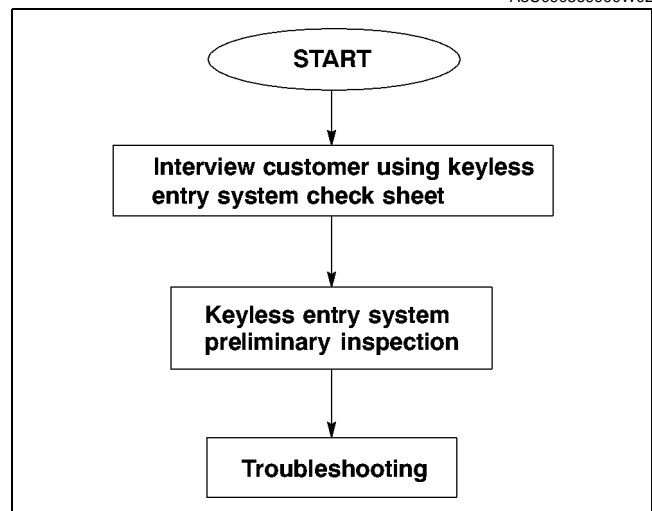

ZLU0903W001

# SYMPTOM TROUBLESHOOTING

## KEYLESS ENTRY SYSTEM CHECK SHEET

A3U090369000W03

### Note

- Use the sheet below as a customer interview sheet when accepting a vehicle for service.
- If the symptom is "Power door lock system does not operate with transmitter at all", find out how the customer uses the keyless entry system by following the check sheet below.

Perform the following inspection with customer:

Q1. What's the customer's complaint?

- Power door lock system does not operate with transmitter (door does not lock/unlock).
- Other \_\_\_\_\_

Q2. Is system factory-installed or after-market?

- Factory-installed system  
→ Go to Q3.
- After-market system  
→ Perform troubleshooting according to after-market keyless entry system manual.

Q3. Operate transmitter with customer from **2.5 m {8.2 ft}** away from center of vehicle. (Make sure the ignition key is either in the LOCK position or removed.)

Does keyless entry system work?

- Yes  
→ Explain the following to the customer:
  - Keyless entry system does not work when ignition switch is in the ON position.
  - Keyless entry system does not work from excessive distances (**more than 2.5 m {8.2 ft}** away from center of vehicle).
- No  
→ Go to Q4.

Q4. Check location where customer uses keyless entry system.

Does a particular area, such as being near TV towers, power plants, power lines or factories, have an effect on malfunction?

- Yes Place \_\_\_\_\_  
→ Area of operation is bad. Explain effect of outside interference on transmitter to customer.
- No  
→ Go to Q5.

Q5. Make sure there are no after-market electrical parts installed on vehicle.

Are there any of the following present?

- Cellular phone
- Radio-wave equipment
- Remote engine starter
- TV, etc.
- Yes Parts \_\_\_\_\_
- No

Perform the keyless entry system preinspection.

Z3U0903W003

# SYMPTOM TROUBLESHOOTING

## KEYLESS ENTRY SYSTEM PREINSPECTION

A3U090369000W04

1. Perform the following pre-inspection before troubleshooting.

STEP	INSPECTION	ACTION	
1	<ul style="list-style-type: none"> <li>Is the system an after-market one?</li> </ul>	Yes	Perform troubleshooting according to after-market keyless entry system manual.
		No	Go to next step.
2	<ul style="list-style-type: none"> <li>Did customer activate keyless entry system when ignition switch was in LOCK position?</li> </ul>	Yes	Go to next step.
		No	Explain to customer that system does not work when ignition switch is in ON position. Turn ignition switch to LOCK position, then go to next step.
3	<ul style="list-style-type: none"> <li>Did customer use keyless entry system in particular area, such as being near TV towers, power plants, power lines or factories?</li> </ul>	Yes	Attempt to lock/unlock doors with transmitter in non-interference area. <ul style="list-style-type: none"> <li><b>If system operates:</b> <ul style="list-style-type: none"> <li>Area of operation is bad. Explain effect of outside interference on transmitter to customer.</li> </ul> </li> <li><b>If system does not operate:</b> <ul style="list-style-type: none"> <li>Go to next step.</li> </ul> </li> </ul>
		No	Go to next step.
4	<ul style="list-style-type: none"> <li>Are any of the following after-market electrical parts on the vehicle?                             <ul style="list-style-type: none"> <li>Cellular phone</li> <li>Radio-wave equipment</li> <li>Remote engine starter</li> <li>TV, etc.</li> </ul> </li> </ul>	Yes	Disconnect after-market electrical part connectors and attempt to lock/unlock doors with transmitter. <ul style="list-style-type: none"> <li><b>If system operates:</b> <ul style="list-style-type: none"> <li>After-market electrical parts are interfering with keyless entry system.</li> </ul> </li> <li><b>If system does not operate:</b> <ul style="list-style-type: none"> <li>Go to next step.</li> </ul> </li> </ul>
		No	Go to next step.
5	<ul style="list-style-type: none"> <li>Perform on-board diagnostic function. (See 09-02A-2 ON-BOARD DIAGNOSTIC FUNCTION [KEYLESS ENTRY SYSTEM])</li> <li>Does on-board diagnostic function work?</li> </ul>	Yes	Go to next step.
		No	Go to Step 7.
6	<ul style="list-style-type: none"> <li>Attempt to reprogram keyless control module ID code.</li> <li>Can keyless control module ID code be reprogrammed?</li> </ul>	Yes	System is normal now.
		No	Go to Step 1 of troubleshooting No.3.
7	<ul style="list-style-type: none"> <li>Did any on-board diagnostic functions work?</li> </ul>	Yes	Go to Step 1 of troubleshooting No.1.
		No	Go to Step 1 of troubleshooting No.2.

09-03

## TROUBLESHOOTING INDEX

A3U090369000W05

No.	TROUBLESHOOTING ITEM	DESCRIPTION	PAGE
1	One or more on-board diagnostic functions inoperative.	<ul style="list-style-type: none"> <li>Malfunction in horn system, hazard warning light system, door lock linkage system, door lock switch system or driver's door key cylinder switch system.</li> </ul>	(See 09-03-4 NO.1 ONE OR MORE ON-BOARD DIAGNOSTIC FUNCTIONS INOPERATIVE)
2	All on-board diagnostic functions inoperative.	<ul style="list-style-type: none"> <li>Malfunction in keyless control module power supply circuit, door switch circuit, cargo compartment light switch circuit (5HB) or keyless control module ground circuit.</li> </ul>	(See 09-03-6 NO.2 ALL ON-BOARD DIAGNOSTIC FUNCTIONS INOPERATIVE)
3	Transmitter ID code cannot be reprogrammed.	<ul style="list-style-type: none"> <li>Malfunction in transmitter battery, transmitter, keyless control module bracket, keyless control module bracket ground screw or keyless control module circuit.</li> </ul>	(See 09-03-7 NO.3 TRANSMITTER ID CODE CANNOT BE REPROGRAMMED)

# SYMPTOM TROUBLESHOOTING

## NO.1 ONE OR MORE ON-BOARD DIAGNOSTIC FUNCTIONS INOPERATIVE

A3U090369000W06

- When performing an asterisked (\*) troubleshooting inspection, shake the wiring harness and connectors while performing the inspection to discover whether poor contact points are the cause of any intermittent malfunctions. If there is a problem, make sure connectors, terminals and wiring harnesses are connected correctly and undamaged.

<b>1</b>	<b>One or more on-board diagnostic functions inoperative</b>
<b>DESCRIPTION</b>	<ul style="list-style-type: none"> <li>Malfunction in horn system, hazard light system, door lock linkage system, door lock switch system or driver's door key cylinder switch system.</li> </ul>
<b>POSSIBLE CAUSE</b>	<ul style="list-style-type: none"> <li>Malfunction in horn system                             <ul style="list-style-type: none"> <li>Horn circuit malfunction</li> <li>Keyless control module malfunction</li> <li>Malfunction in wiring harness between keyless control module and horn relay</li> </ul> </li> <li>Malfunction in hazard light system                             <ul style="list-style-type: none"> <li>Hazard light circuit</li> <li>Keyless control module malfunction</li> <li>Malfunction in wiring harness between keyless control module and flasher control module</li> </ul> </li> <li>Malfunction in door lock linkage</li> <li>Malfunction in door lock switch system</li> <li>Malfunction in keyless control module door unlock signal circuit                             <ul style="list-style-type: none"> <li>Keyless control module malfunction</li> <li>Malfunction in wiring harness between keyless control module and door lock control module</li> </ul> </li> <li>Malfunction in driver-side door key cylinder switch system</li> <li>Malfunction in keyless control module door lock/unlock signal circuit                             <ul style="list-style-type: none"> <li>Keyless control module malfunction</li> <li>Malfunction in wiring harness between keyless control module and door lock control module</li> </ul> </li> </ul>

### Diagnostic procedure

STEP	INSPECTION	ACTION	
1	<b>CHECK HORN, AND HAZARD WARNING LIGHT OPERATION DURING ON-BOARD DIAGNOSIS</b> <ul style="list-style-type: none"> <li>Did all of the following items work during on-board diagnostic function operation?                                     <ul style="list-style-type: none"> <li>Horns sounded intermittently</li> <li>Hazard warning lights flashed</li> </ul> </li> </ul>	Yes	Go to Step 8.
		No	Go to next step.
2	<b>CHECK HORN OPERATION DURING ON-BOARD DIAGNOSIS</b> <ul style="list-style-type: none"> <li>Did horns sound intermittently during on-board diagnostic function operation?</li> </ul>	Yes	Go to Step 5.
		No	Go to next step.
3	<b>INSPECT HORN CIRCUIT</b> <ul style="list-style-type: none"> <li>Do horns sound when depressing horn switch on vehicle?</li> </ul>	Yes	Go to next step.
		No	Inspect horn circuit.
*4	<b>CHECK TO SEE WHETHER MALFUNCTION IS IN WIRING HARNESS (BETWEEN KEYLESS CONTROL MODULE AND HORN RELAY) OR KEYLESS CONTROL MODULE</b> <ul style="list-style-type: none"> <li>Measure voltage at keyless control module connector terminal E during on-board diagnostic function operation.                                     <ul style="list-style-type: none"> <li><b>B+ → below 1.0 V → B+ → below 1.0 V → B+</b></li> </ul> </li> <li>Is voltage as above?</li> </ul>	Yes	Recheck malfunction symptoms, then repeat from Step 1 if malfunction recurs.
		No	Inspect wiring harness between keyless control module and horn relay. <ul style="list-style-type: none"> <li>If wiring harness is OK, replace keyless control module and reprogram transmitter ID code, then go to Step 16.</li> <li>If wiring harness malfunctions, repair wiring harness, then go to Step 16.</li> </ul>
5	<b>CHECK HAZARD WARNING LIGHT OPERATION DURING ON-BOARD DIAGNOSIS</b> <ul style="list-style-type: none"> <li>Did hazard warning lights flash during on-board diagnostic function operation?</li> </ul>	Yes	Recheck malfunction symptoms, then repeat from Step 1 if malfunction recurs.
		No	Go to next step.
6	<b>INSPECT HAZARD WARNING LIGHT CIRCUIT</b> <ul style="list-style-type: none"> <li>Do hazard warning lights flash when hazard warning switch is on?</li> </ul>	Yes	Go to next step.
		No	Inspect hazard light circuit.
*7	<b>CHECK TO SEE WHETHER MALFUNCTION IS IN WIRING HARNESS (BETWEEN KEYLESS CONTROL MODULE AND FLASHER CONTROL MODULE) OR KEYLESS CONTROL MODULE</b> <ul style="list-style-type: none"> <li>Measure voltage at keyless control module connector terminal H during on-board diagnostic function operation.                                     <ul style="list-style-type: none"> <li><b>Alternates between B+ and below 1.0 V</b></li> </ul> </li> <li>Is voltage as above?</li> </ul>	Yes	Recheck malfunction symptoms, then repeat from Step 1 if malfunction recurs.
		No	Inspect wiring harness between keyless control module and flasher control module. <ul style="list-style-type: none"> <li>If wiring harness is OK, replace keyless control module and reprogram transmitter ID code, then go to Step 16.</li> <li>If wiring harness malfunctions, repair wiring harness, then go to Step 16.</li> </ul>

## SYMPTOM TROUBLESHOOTING

STEP	INSPECTION	ACTION	
8	<b>MAKE SURE THAT ALL DOORS LOCK AND UNLOCK DURING ON-BOARD DIAGNOSIS</b> <ul style="list-style-type: none"> <li>• Did all of the following items work during on-board diagnostic function operation?                             <ul style="list-style-type: none"> <li>— All doors unlocked and locked</li> <li>— Driver-side door unlocked</li> </ul> </li> </ul>	Yes	Recheck malfunction symptoms, then repeat from Step 1 if malfunction recurs.
		No	Go to next step.
9	<b>INSPECT DOOR LOCK LINKAGE</b> <ul style="list-style-type: none"> <li>• Operate inner door lock knob and make sure door locks and unlocks manually.</li> <li>• Does every door lock system work?</li> </ul>	Yes	Go to next step.
		No	Inspect door lock linkage.
10	<b>MAKE SURE THAT ALL DOORS UNLOCK DURING ON-BOARD DIAGNOSIS</b> <ul style="list-style-type: none"> <li>• Did all doors unlock during on-board diagnostic function operation?</li> </ul>	Yes	Go to Step 13.
		No	Go to next step.
11	<b>CHECK TO SEE WHETHER MALFUNCTION IS IN DRIVER'S DOOR LOCK SWITCH SYSTEM OR ELSEWHERE</b> <ul style="list-style-type: none"> <li>• Do all doors unlock when door lock switch UNLOCK button is pressed?</li> </ul>	Yes	Go to next step.
		No	Inspect power door lock system.
*12	<b>CHECK TO SEE WHETHER MALFUNCTION IS IN WIRING HARNESS (BETWEEN KEYLESS CONTROL MODULE AND DOOR LOCK CONTROL MODULE) OR KEYLESS CONTROL MODULE</b> <ul style="list-style-type: none"> <li>• Measure voltage at keyless control module connector terminal K during on-board diagnostic function operation.                             <ul style="list-style-type: none"> <li>— All doors unlocked: <b>5 V</b>→<b>below 1.0 V</b>→<b>5 V</b></li> </ul> </li> <li>• Is voltage as above?</li> </ul>	Yes	Recheck malfunction symptoms, then repeat from Step 1 if malfunction recurs.
		No	Inspect wiring harness between keyless control module and door lock control module. <ul style="list-style-type: none"> <li>• If wiring harness is OK, replace keyless control module and reprogram transmitter ID code, then go to Step 16.</li> <li>• If wiring harness malfunctions, repair wiring harness, then go to Step 16.</li> </ul>
13	<b>MAKE SURE THAT ALL DOORS LOCK AND DRIVER'S DOOR UNLOCKS DURING ON-BOARD DIAGNOSIS</b> <ul style="list-style-type: none"> <li>• Did all of the following items work during on-board diagnostic function operation?                             <ul style="list-style-type: none"> <li>— All doors locked</li> <li>— Driver-side door unlocked</li> </ul> </li> </ul>	Yes	Recheck malfunction symptoms, then repeat from Step 1 if malfunction recurs.
		No	Go to next step.
14	<b>CHECK TO SEE WHETHER MALFUNCTION IS IN DRIVER'S DOOR KEY CYLINDER SWITCH SYSTEM OR ELSEWHERE</b> <ul style="list-style-type: none"> <li>• Do all of the following items work when inserting ignition key into driver-side door key cylinder and operating ignition key?                             <ul style="list-style-type: none"> <li>— All doors locked</li> <li>— Driver-side door unlocked</li> </ul> </li> </ul>	Yes	Go to next step.
		No	Inspect power door lock system.
*15	<b>CHECK TO SEE WHETHER MALFUNCTION IS IN WIRING HARNESS (BETWEEN KEYLESS CONTROL MODULE AND DOOR LOCK CONTROL MODULE) OR KEYLESS CONTROL MODULE</b> <ul style="list-style-type: none"> <li>• Measure voltage at keyless control module connector terminal O during on-board diagnostic function operation.                             <ul style="list-style-type: none"> <li>— All doors locked: <b>5 V</b>→<b>2.5 V</b>→<b>5 V</b></li> <li>— Driver-side door unlocked: <b>5 V</b>→<b>below 1.0 V</b>→<b>5 V</b></li> </ul> </li> <li>• Is voltage as above?</li> </ul>	Yes	Recheck malfunction symptoms, then repeat from Step 1 if malfunction recurs.
		No	Inspect wiring harness between keyless control module and door lock control module. <ul style="list-style-type: none"> <li>• If wiring harness is OK, replace keyless control module and reprogram transmitter ID code, then go to next step.</li> <li>• If wiring harness malfunction, repair wiring harness, then go to next step.</li> </ul>
16	<b>RECHECK MALFUNCTION SYMPTOM AFTER REPAIR</b> <ul style="list-style-type: none"> <li>• Does keyless entry system operate properly?</li> </ul>	Yes	Troubleshooting completed. Explain repairs to customer.
		No	Recheck malfunction symptoms, then repeat from Step 1 if malfunction recurs.

09-03

## SYMPTOM TROUBLESHOOTING

### NO.2 ALL ON-BOARD DIAGNOSTIC FUNCTIONS INOPERATIVE

A3U090369000W07

- When performing an asterisked (\*) troubleshooting inspection, shake the wiring harness and connectors while performing the inspection to discover whether poor contact points are the cause of any intermittent malfunctions. If there is a problem, make sure connectors, terminals and wiring harnesses are connected correctly and undamaged.

<b>2</b>	<b>All on-board diagnostic functions inoperative</b>
<b>DESCRIPTION</b>	<ul style="list-style-type: none"> <li>Malfunction in keyless control module power supply circuit, door switch circuit, cargo compartment light switch circuit (5HB) or keyless control module ground circuit.</li> </ul>
<b>POSSIBLE CAUSE</b>	<ul style="list-style-type: none"> <li>Malfunction in IG1, B+ signal circuit of keyless control module                             <ul style="list-style-type: none"> <li>Keyless control module power supply fuse malfunction</li> <li>Malfunction in wiring harness between keyless control module power supply fuse(s) and keyless control module itself</li> </ul> </li> <li>Malfunction in keyless control module door open/closed signal circuit                             <ul style="list-style-type: none"> <li>Door switch system malfunction</li> <li>Keyless control module malfunction</li> <li>Malfunction in wiring harness between keyless control module and door switch</li> </ul> </li> <li>Malfunction in keyless control module's liftgate open/closed signal circuit (5HB)                             <ul style="list-style-type: none"> <li>Cargo compartment light switch system malfunction</li> <li>Keyless control module malfunction</li> <li>Malfunction in wiring harness between keyless control module and cargo compartment light switch</li> </ul> </li> <li>Malfunction in keyless control module GND signal circuit                             <ul style="list-style-type: none"> <li>Malfunction in wiring harness between keyless control module and ground</li> </ul> </li> </ul>

#### Diagnostic procedure

STEP	INSPECTION		ACTION
1	<b>INSPECT KEYLESS CONTROL MODULE POWER SUPPLY FUSES</b> <ul style="list-style-type: none"> <li>Are keyless control module power supply fuses okay?</li> </ul>	Yes	Go to next step.
		No	Check for a short to ground on blown fuse circuit. Repair or replace as necessary. Install appropriate amperage fuse.
2	<b>INSPECT DOOR SWITCH INSTALLATION</b> <ul style="list-style-type: none"> <li>Are door switches installed securely?</li> </ul>	Yes	Go to next step.
		No	Install door switches securely, then go back to Step 5 of keyless entry system preliminary inspection.
*3	<b>CHECK TO SEE WHETHER MALFUNCTION IS IN WIRING HARNESS (LACK OF CONTINUITY BETWEEN FUSE BLOCK AND KEYLESS CONTROL MODULE) OR ELSEWHERE</b> <ul style="list-style-type: none"> <li>Turn ignition switch to ON position.</li> <li>Measure voltage at following keyless control module terminals:                             <ul style="list-style-type: none"> <li>IG1 signal (Terminal A)</li> <li>B+ signal (Terminal B)</li> </ul> </li> <li>Is voltage <b>approximately 12 V</b>?</li> </ul>	Yes	Go to next step.
		No	Repair wiring harness between fuse block and keyless control module, then go to Step 8.
*4	<b>CHECK TO SEE WHETHER MALFUNCTION IS IN WIRING HARNESS (SHORT TO B+ BETWEEN FUSE BLOCK AND KEYLESS CONTROL MODULE, OR BETWEEN KEYLESS CONTROL MODULE AND GROUND) OR ELSEWHERE</b> <ul style="list-style-type: none"> <li>Turn ignition switch to LOCK position.</li> <li>Disconnect keyless control module connector.</li> <li>Measure voltage at following keyless control module connector terminal:                             <ul style="list-style-type: none"> <li>IG1 signal (Terminal A)</li> </ul> </li> <li>Is voltage <b>approximately 12 V</b>?</li> </ul>	Yes	Repair malfunctioning wiring harness, then go to Step 8.
		No	Go to next step.
*5	<b>CHECK TO SEE WHETHER MALFUNCTION IS IN WIRING HARNESS (LACK OF CONTINUITY BETWEEN KEYLESS CONTROL MODULE AND GROUND) OR ELSEWHERE</b> <ul style="list-style-type: none"> <li>Is there continuity between keyless control module connector terminal L and ground?</li> </ul>	Yes	Go to next step.
		No	Repair wiring harness between keyless control module and ground, then go to Step 8.
6	<b>CHECK FOR CHECK CODE 04 IN INSTRUMENT CLUSTER</b> <ul style="list-style-type: none"> <li>Inspect door switch using instrument cluster input/output check mode. (See 09-22-5 INSTRUMENT CLUSTER INPUT/OUTPUT CHECK MODE)</li> <li>Does DTC 04 function properly?</li> </ul>	Yes	Go to next step.
		No	Repair door switch system using DTC 04 inspection procedure, then go to Step 8.

## SYMPTOM TROUBLESHOOTING

STEP	INSPECTION		ACTION
7	<b>INSPECT KEYLESS CONTROL MODULE OR WIRING HARNESS (BETWEEN KEYLESS CONTROL MODULE AND DOOR SWITCHES, CARGO COMPARTMENT LIGHT SWITCH FOR CONTINUITY)</b> <ul style="list-style-type: none"> <li>Open the driver-side door.</li> <li>Open the liftgate.</li> <li>Is there continuity between keyless control module connector terminal C, D and ground?</li> </ul>	Yes	Replace keyless control module and reprogram keyless control module ID code, then go to next step.
		No	Repair wiring harness between keyless control module and door switches, cargo compartment light switch then go to next step.
8	<b>RECHECK MALFUNCTION SYMPTOM AFTER REPAIR</b> <ul style="list-style-type: none"> <li>Does keyless entry system operate properly?</li> </ul>	Yes	Troubleshooting completed. Explain repairs to customer.
		No	Recheck malfunction symptoms, then repeat from Step 1 if malfunction recurs.

### NO.3 TRANSMITTER ID CODE CANNOT BE REPROGRAMMED

A3U090369000W08

3	Transmitter ID code cannot be reprogrammed
<b>DESCRIPTION</b>	<ul style="list-style-type: none"> <li>Malfunction in transmitter battery, transmitter keyless control module bracket, keyless control module bracket ground screw or keyless control module circuit.</li> </ul>
<b>POSSIBLE CAUSE</b>	<ul style="list-style-type: none"> <li>Malfunction in transmitter battery, transmitter, keyless control module bracket, keyless control module bracket ground screw or keyless control module circuit                             <ul style="list-style-type: none"> <li>— Transmitter battery, transmitter, keyless control module bracket, keyless control module bracket ground screw or keyless control module malfunction</li> </ul> </li> </ul>

#### Diagnostic procedure

STEP	INSPECTION		ACTION
1	<b>INSPECT TRANSMITTER BATTERY INSTALLATION AND TYPE</b> <ul style="list-style-type: none"> <li>Visually inspect transmitter battery.</li> <li>Are below items okay?                             <ul style="list-style-type: none"> <li>— Transmitter battery installation (correct polarity)</li> <li>— Battery type (CR2025)</li> </ul> </li> </ul>	Yes	Go to next step.
		No	Set transmitter battery properly or replace with specified transmitter battery (CR2025), then go to Step 8.
2	<b>INSPECT TRANSMITTER BATTERY TERMINALS FOR RUST AND POOR CONNECTION</b> <ul style="list-style-type: none"> <li>Visually inspect transmitter.                             <ul style="list-style-type: none"> <li>— Is there rust on transmitter battery terminals (positive or negative pole)?</li> <li>— Is there poor connection between terminals and battery?</li> </ul> </li> </ul>	Yes	Replace transmitter battery or repair transmitter battery terminal, then go to Step 8.
		No	Go to next step.
3	<b>INSPECT TRANSMITTER BATTERY</b> <ul style="list-style-type: none"> <li>Inspect transmitter battery.</li> <li>Is battery voltage normal?</li> </ul>	Yes	Go to next step.
		No	Replace transmitter battery, then go to Step 8.
4	<b>INSPECT KEYLESS CONTROL MODULE BRACKET INSTALLATION</b> <ul style="list-style-type: none"> <li>Is keyless control module bracket installed securely?</li> </ul>	Yes	Go to next step.
		No	Install bracket securely, then go back to Step 6 of keyless entry system preliminary inspection.
5	<b>INSPECT GROUND SCREW INSTALLATION BETWEEN KEYLESS CONTROL MODULE AND KEYLESS CONTROL MODULE BRACKET</b> <ul style="list-style-type: none"> <li>Are keyless control module and keyless control module bracket connected securely to ground screw?</li> </ul>	Yes	Go to next step.
		No	Install screw securely, then go back to Step 6 of keyless entry system preliminary inspection.
6	<b>CHECK TO SEE WHETHER MALFUNCTION IS IN TRANSMITTER BATTERY OR ELSEWHERE</b> <ul style="list-style-type: none"> <li>Replace with a known good transmitter battery.</li> <li>Does keyless entry system operate properly?</li> </ul>	Yes	Replace transmitter battery, then go to Step 8.
		No	Go to next step.
7	<b>CHECK TO SEE WHETHER MALFUNCTION IS IN TRANSMITTER OR KEYLESS CONTROL MODULE</b> <ul style="list-style-type: none"> <li>Reprogram keyless control module ID code using another known good transmitter.</li> <li>Does keyless entry system operate properly?</li> </ul>	Yes	Replace transmitter and reprogram transmitter ID code, then go to next step.
		No	Replace keyless control module and reprogram keyless control module ID code, then go to next step.
8	<b>RECHECK MALFUNCTION SYMPTOM AFTER REPAIR</b> <ul style="list-style-type: none"> <li>Does keyless entry system operate properly?</li> </ul>	Yes	Troubleshooting completed. Explain repairs to customer.
		No	Recheck malfunction symptoms, then repeat from Step 1 if malfunction recurs.

09-03



# 09-10 BODY PANELS

FUEL-FILLER LID ADJUSTMENT . . . . . 09-10-1  
**FUEL-FILLER LID**  
 REMOVAL/INSTALLATION . . . . . 09-10-1  
 HOOD ADJUSTMENT . . . . . 09-10-2  
**HOOD REMOVAL/INSTALLATION . . . . . 09-10-3**  
**TRUNK LID ADJUSTMENT . . . . . 09-10-3**  
**TRUNK LID REMOVAL/INSTALLATION 09-10-4**  
 Balance Spring Removal Note . . . . . 09-10-2  
**FRONT BUMPER**  
**REMOVAL/INSTALLATION . . . . . 09-10-5**  
 Front Bumper Removal Note . . . . . 09-10-5

Front Bumper Installation Note . . . . . 09-10-6  
**FRONT BUMPER**  
**DISASSEMBLY/ASSEMBLY . . . . . 09-10-6**  
 Front Bumper Mesh Removal Note . . . . . 09-10-6  
 Hole Cover Removal Note . . . . . 09-10-7  
**REAR BUMPER**  
**REMOVAL/INSTALLATION . . . . . 09-10-7**  
 4SD . . . . . 09-10-7  
 5HB . . . . . 09-10-7  
**FRONT FENDER PANEL**  
**REMOVAL/INSTALLATION . . . . . 09-10-8**

## FUEL-FILLER LID ADJUSTMENT

1. Measure the gap and height between the fuel-filler lid and the body.
  - If not as specified, loosen the fuel-filler lid installation bolts, and reposition the fuel-filler lid.

### Clearance

- a: 2.1—4.1 mm {0.09—0.16 in}
- b: 2.5—4.5 mm {0.10—0.17 in}
- c: 2.5—4.5 mm {0.10—0.17 in}
- d: 2.3—4.3 mm {0.10—0.16 in}
- e: -0.5—1.5 mm {-0.020—0.059 in}

2. Tighten the bolts.

## FUEL-FILLER LID REMOVAL/INSTALLATION

1. Remove the bolts, then remove the fuel-filler lid.
2. Install in the reverse order of removal.
3. Adjust the fuel-filler lid. (See 09-10-1 FUEL-FILLER LID ADJUSTMENT.)

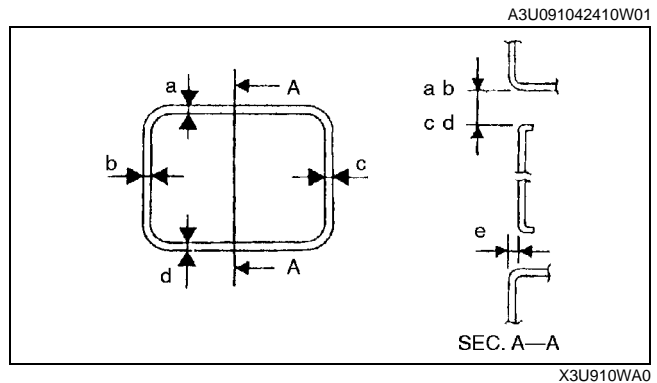

09-10

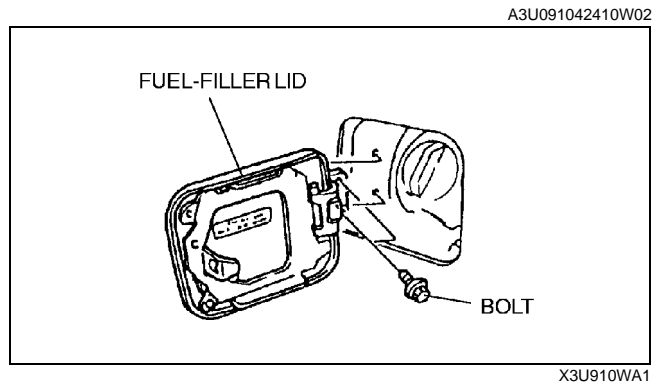

# BODY PANELS

## HOOD ADJUSTMENT

A3U091052310W01

1. Measure the gap and height between the bonnet and the body.
  - If not as specified, adjust the gap and height.

### Clearance

- a: 3.7—8.3 mm {0.15—0.33 in}
- b: 4.0—8.0 mm {0.16—0.32 in}
- c: 3.0—5.0 mm {0.12—0.20 in}
- d: -1.0—1.0 mm {-0.04—0.04 in}

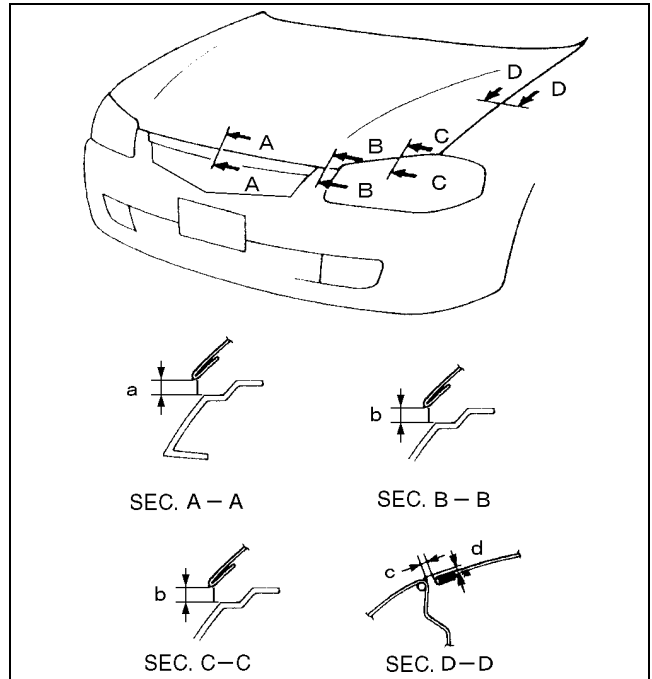

Y3E7710W001

## Gap Adjustment

1. Loosen the bonnet installation bolts and reposition the bonnet.

### Tightening torque

18.6—28.4 N·m {1.9—2.9 kgf·m, 13—20 ft·lbf}

2. Tighten the bolts.

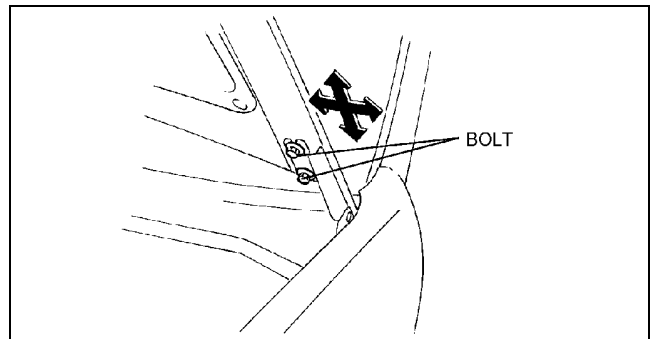

Y3E7710W002

## Height Adjustment

1. Turn the stop rubber to adjust the height of the bonnet.

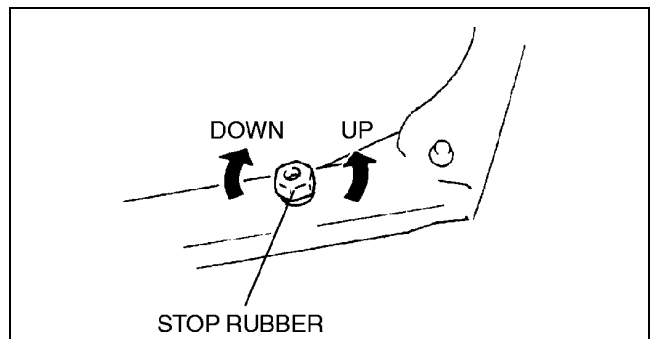

X5U910WA3

# BODY PANELS

## HOOD REMOVAL/INSTALLATION

A3U091052310W02

### Warning

- Removing the hood without supporting it can be dangerous. The hood may fall and injure you. Always perform these procedures together with at least another person.

1. Disconnect the windshield washer hose.
2. To remove the hood hinge, remove the front fender panel. (See 09-10-8 FRONT FENDER PANEL REMOVAL/INSTALLATION.)
3. Remove in the order indicated in the table.

1	Hood insulator (FP)
2	Shroud seal weatherstrip
3	Parting seal weatherstrip
4	Hood
5	Hood hinge
6	Hood stay

4. Install in the reverse order of removal.
5. Adjust the hood. (See 09-10-2 HOOD ADJUSTMENT.)

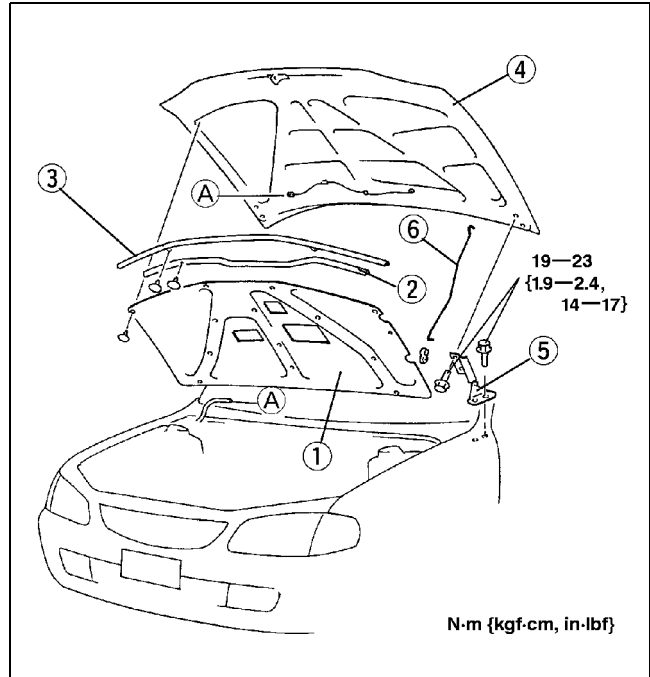

Y3U910WA0

## TRUNK LID ADJUSTMENT

1. Measure the gap between the trunk lid and the body panel.
  - If not as specified, loosen the trunk lid hinge installation nuts and reposition the trunk lid.

### Clearance

- a: 3.3—5.3 mm {0.13—0.20 in}
- b: -1.0—1.0 mm {-0.040—0.039 in}
- c: 5.0—11.0 mm {0.20—0.43 in}

2. Tighten the nuts.

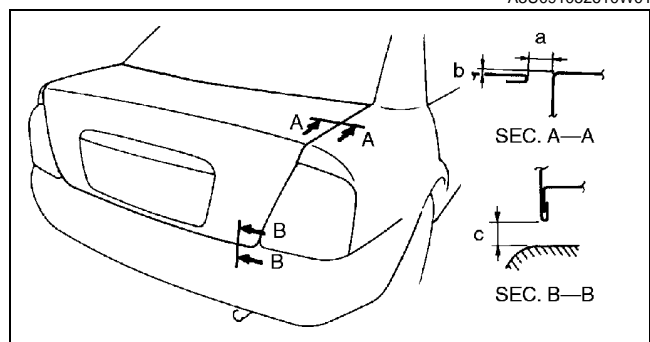

X3U910WA6

09-10

# BODY PANELS

## TRUNK LID REMOVAL/INSTALLATION

A3U091052610W02

### Warning

- Removing the trunk lid without supporting it can be dangerous. The trunk lid may fall and injure you. Always perform these procedures together with at least another person.

1. Disconnect the negative battery cable.
2. To remove the trunk lid hinge, remove the rear package trim. (See 09-17-12 REAR PACKAGE TRIM REMOVAL/INSTALLATION.)
3. Remove in the order indicated in the table.

1	Connector
2	Trunk lid
3	Balance spring (See 09-10-4 Balance Spring Removal Note)
4	Trunk lid hinge

4. Install in the reverse order of removal.
5. Adjust the trunk lid. (See 09-10-3 TRUNK LID ADJUSTMENT.)

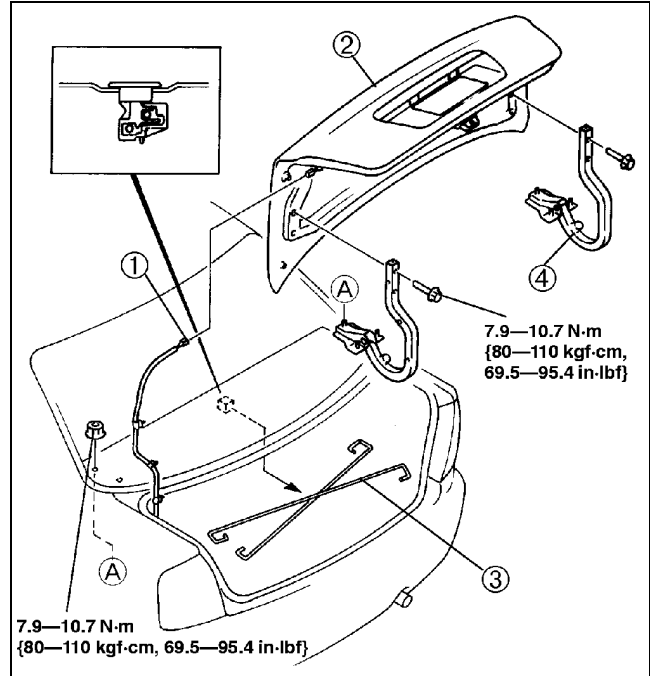

X3U910WA7

### Balance Spring Removal Note

#### Note

- The balance springs are under high tension.

1. Push the tab of the clip to open the cover using a tape-wrapped flathead screwdriver.
2. Remove the balance springs from the clip.

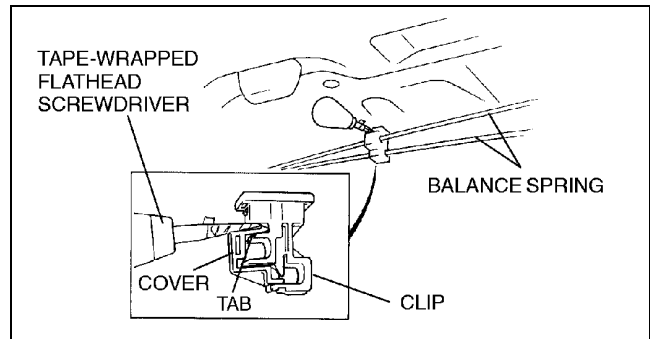

Y3U910WA3

3. Remove the balance spring from the trunk lid hinge using a tape-wrapped flathead screwdriver.

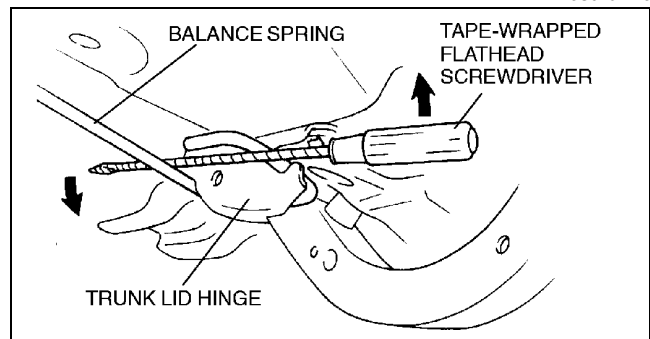

X3U910WA9

# BODY PANELS

## FRONT BUMPER REMOVAL/INSTALLATION

A3U091050031W01

1. Disconnect the negative battery cable.
2. Disconnect the front fog light connector.
3. To remove the bumper reinforcement, remove the front bumper and washer tank, then remove the bumper reinforcement installation nuts.
4. Remove in the order indicated in the table.

1	Screw A
2	Fastener
3	Screw B
4	Bolt
5	Front bumper (See 09-10-5 Front Bumper Removal Note.) (See 09-10-6 Front Bumper Installation Note.)
6	Front bumper reinforcement

5. Install in the reverse order of removal.
6. Adjust the front fog light aiming. (See 09-18-9 FRONT FOG LIGHT ADJUSTMENT.)

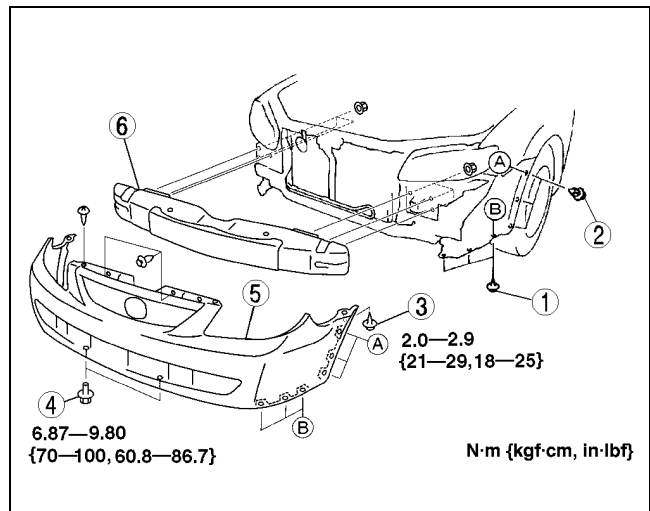

Z3U0910W004

### Front Bumper Removal Note

1. While supporting the connection between the front bumper and bracket, pull the front bumper forward to disengage the connection.

#### Note

- The connection between the front bumper and bracket does not disengage until the front bumper is pulled forward. Be sure to pull the front bumper forward to disengage it from the bracket.

2. Remove the front bumper.

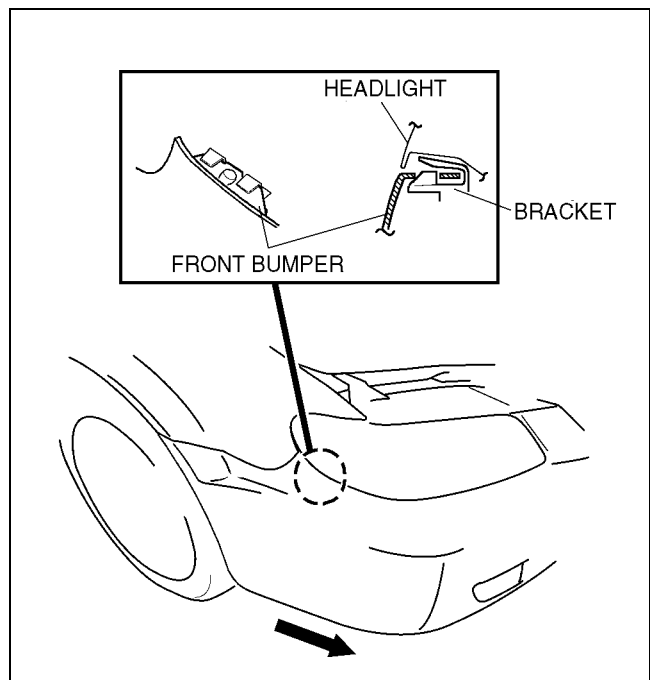

Y3E7726W004

09-10

# BODY PANELS

## Front Bumper Installation Note

1. Spread the front bumper ends (wheel arches) apart.
2. Attach the front bumper to the body.
3. Press the front bumper connection portion into the body to engage with the bracket.

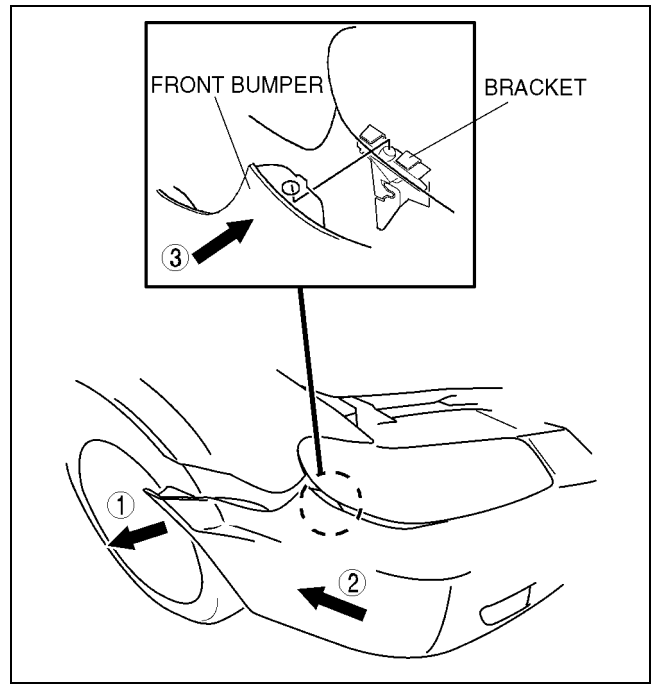

Y3E7726W005

## FRONT BUMPER DISASSEMBLY/ASSEMBLY

A3U091050031W02

1. Remove the radiator grille.
2. Disassemble in the order indicated in the table.

1	Front bumper mesh (See 09-10-6 Front Bumper Mesh Removal Note.)
2	Hole cover (See 09-10-7 Hole Cover Removal Note.)
3	Front bumper fascia

3. Assemble in the reverse order of disassembly.

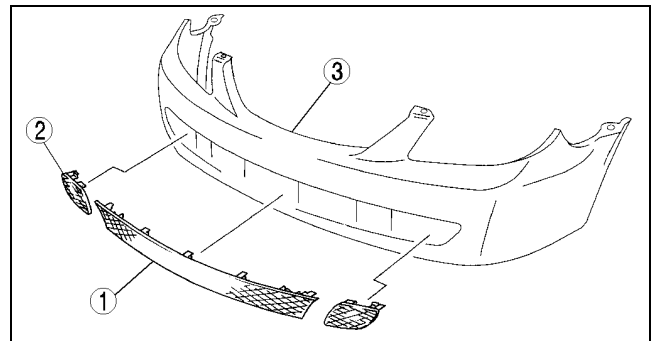

Z3U0910W001

## Front Bumper Mesh Removal Note

1. Push the tabs of front bumper mesh forward from the back of the front bumper fascia to unhook the front bumper mesh.

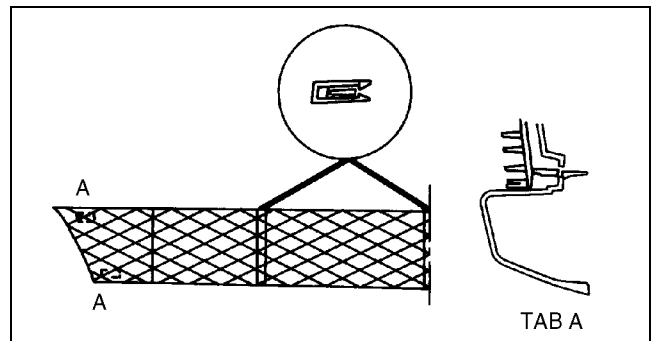

Z3U0910W002

# BODY PANELS

## Hole Cover Removal Note

1. Push the tabs on the hole cover forward from the back of the front bumper fascia to unhook the front bumper mesh.

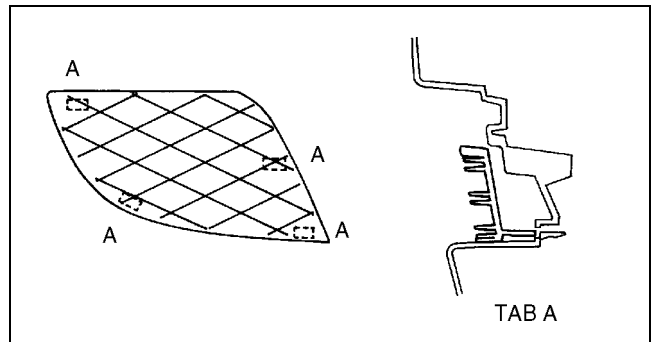

Z3U0910W003

## REAR BUMPER REMOVAL/INSTALLATION

### 4SD

1. Disconnect the negative battery cable.
2. Remove the rear combination lights. (See 09-18-10 REAR COMBINATION LIGHT REMOVAL/INSTALLATION.)
3. Remove in the order indicated in the table.

1	Bolt A
2	Screw
3	Bolt B
4	Fastener A
5	Fastener B
6	Rear bumper fascia
7	Nut A
8	Nut B
9	Energy absorption foam
10	Rear bumper reinforcement

4. Install in the reverse order of removal.

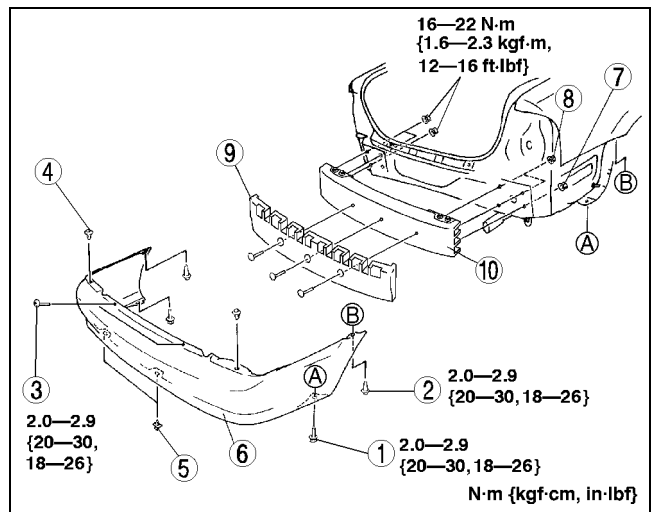

A3U0910W001

09-10

### 5HB

1. Disconnect the negative battery cable.
2. Remove the rear combination lights. (See 09-18-10 REAR COMBINATION LIGHT REMOVAL/INSTALLATION.)
3. Remove in the order indicated in the table.

1	Bolt A
2	Screw
3	Fastener A
4	Bolt B
5	Fastener B
6	Rear bumper fascia
7	Nut
8	Fastener C
9	Fastener D
10	Energy absorption foam
11	Rear bumper reinforcement

4. Install in the reverse order of removal.

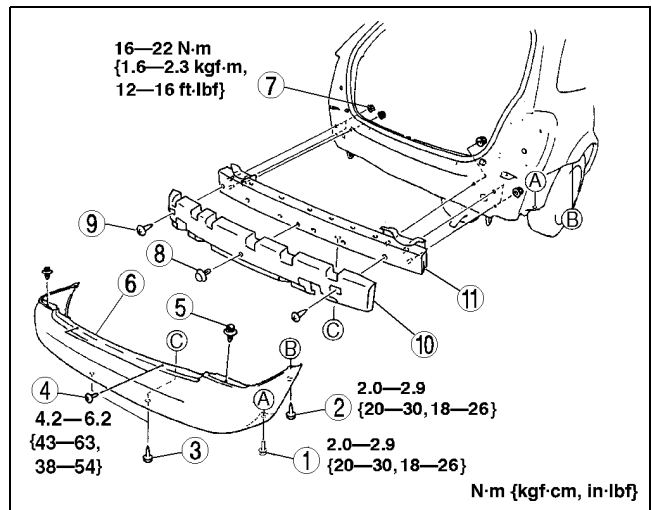

A3U0910W002

## BODY PANELS

### FRONT FENDER PANEL REMOVAL/INSTALLATION

A3U091052110W01

1. Disconnect the negative battery cable.
2. Remove the front combination light. (See 09-18-5 FRONT COMBINATION LIGHT REMOVAL/INSTALLATION.)
3. Remove in the order indicated in the table.

1	Mud guard
2	Front fender panel

4. Install in the reverse order of removal.
5. Adjust the headlight aiming. (See 09-18-5 HEADLIGHT ADJUSTMENT.)

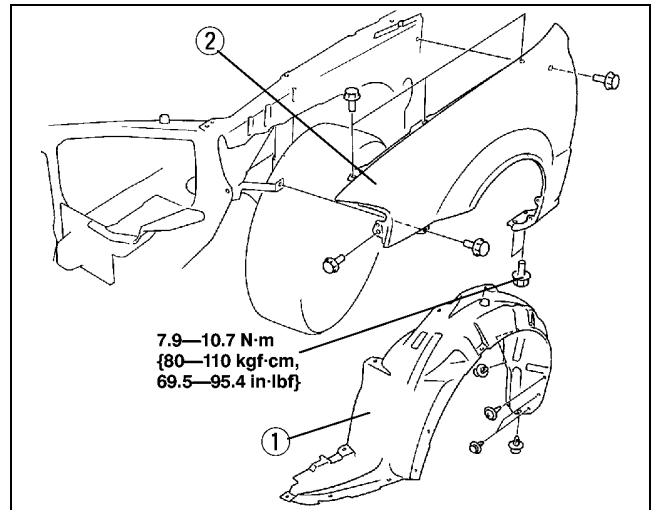

X3U910WAD



# 09-11 DOORS AND LIFTGATE

FRONT DOOR ADJUSTMENT ..... 09-11-1  
 FRONT DOOR  
 REMOVAL/INSTALLATION ..... 09-11-1  
 Connector Removal Note ..... 09-11-2  
 Connector Installation Note ..... 09-11-2  
 FRONT DOOR  
 DISASSEMBLY/ASSEMBLY ..... 09-11-2  
 REAR DOOR ADJUSTMENT ..... 09-11-4

REAR DOOR  
 REMOVAL/INSTALLATION ..... 09-11-4  
 Connector Removal Note ..... 09-11-5  
 Connector Installation Note ..... 09-11-5  
 REAR DOOR  
 DISASSEMBLY/ASSEMBLY ..... 09-11-5  
 LIFTGATE  
 REMOVAL/INSTALLATION ..... 09-11-7  
 LIFTGATE ADJUSTMENT ..... 09-11-9  
 STAY DAMPER DISPOSAL ..... 09-11-9

## FRONT DOOR ADJUSTMENT

1. Measure the gap and height between the front door and the body.
  - If not as specified, loosen the door hinge installation bolts or the door lock striker installation screws, and reposition the door. (See 09-11-1 FRONT DOOR REMOVAL/INSTALLATION.) (See 09-14-7 DOOR LOCK STRIKER REMOVAL/INSTALLATION.)

### Clearance

- a: 3.0—5.0 mm {0.12—0.19 in}
- b: -1.0—1.0 mm {-0.040—0.039 in}
- c: 3.5—5.5 mm {0.14—0.21 in}
- d: -1.0—0.5 mm {-0.040—0.019 in}

2. Tighten the bolts or screws.

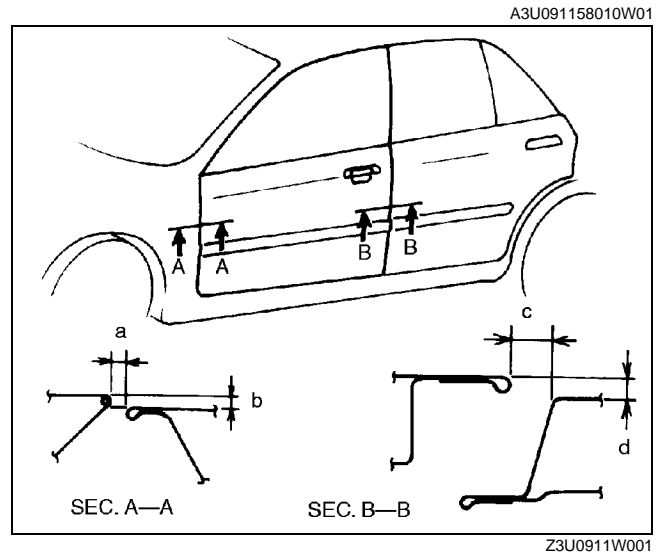

09-11

## FRONT DOOR REMOVAL/INSTALLATION

1. Disconnect the negative battery cable.
2. To remove the front door hinge, remove the front fender panel. (See 09-10-8 FRONT FENDER PANEL REMOVAL/INSTALLATION.)
3. To remove the checker, remove the door speaker. (See 09-20-3 FRONT DOOR SPEAKER REMOVAL/INSTALLATION.)
4. Remove in the order indicated in the table.

1	Connector (See 09-11-2 Connector Removal Note) (See 09-11-2 Connector Installation Note)
2	Checker pin
3	Front door hinge
4	Front door
5	Checker

5. Install in the reverse order of removal.
6. Adjust the front door. (See 09-11-1 FRONT DOOR ADJUSTMENT.)

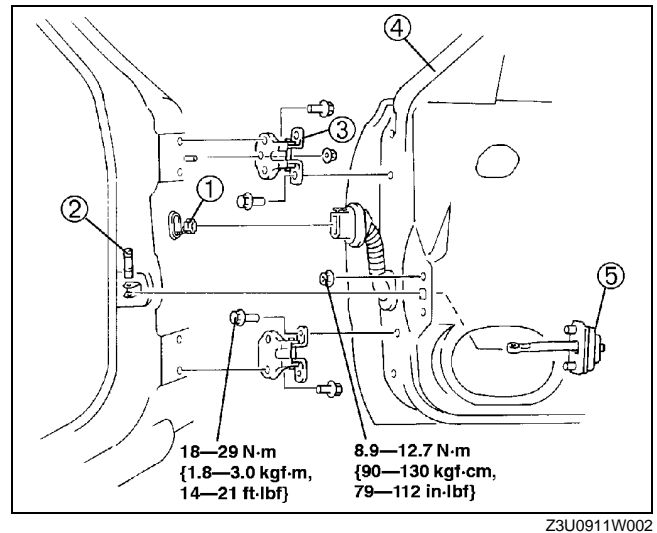

## DOORS AND LIFTGATE

### Connector Removal Note

1. Push the rubber boot backward.
2. Pull the pin up.
3. Remove the rubber boot from the connector.

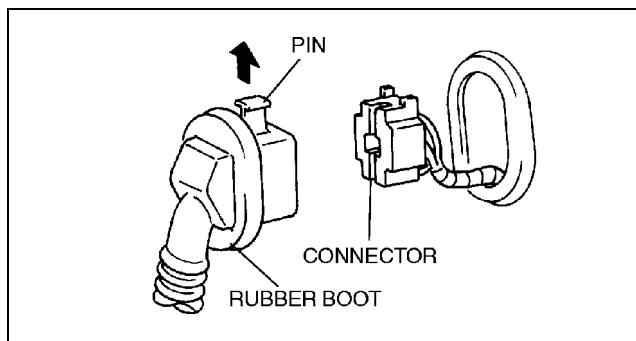

X3U911WA2

### Connector Installation Note

1. Connect the connector and the rubber boot.
2. Push the pin down.
3. Install the rubber boot on the body.

### FRONT DOOR DISASSEMBLY/ASSEMBLY

1. Lower or raise the front door glass so that the distance from the top of the front door glass at the rear end to the upper part of the front beltline molding is **130 mm {5.12 in}**.
2. Disconnect the negative battery cable.
3. Remove the front door trim. (See 09-17-9 FRONT DOOR TRIM REMOVAL/INSTALLATION.)

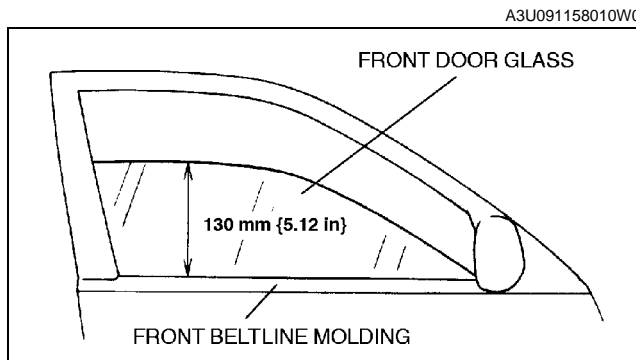

A3U091158010W03  
Y3U911W01

## DOORS AND LIFTGATE

4. Disassemble in the order indicated in the table.
5. Assemble in the reverse order of disassembly.

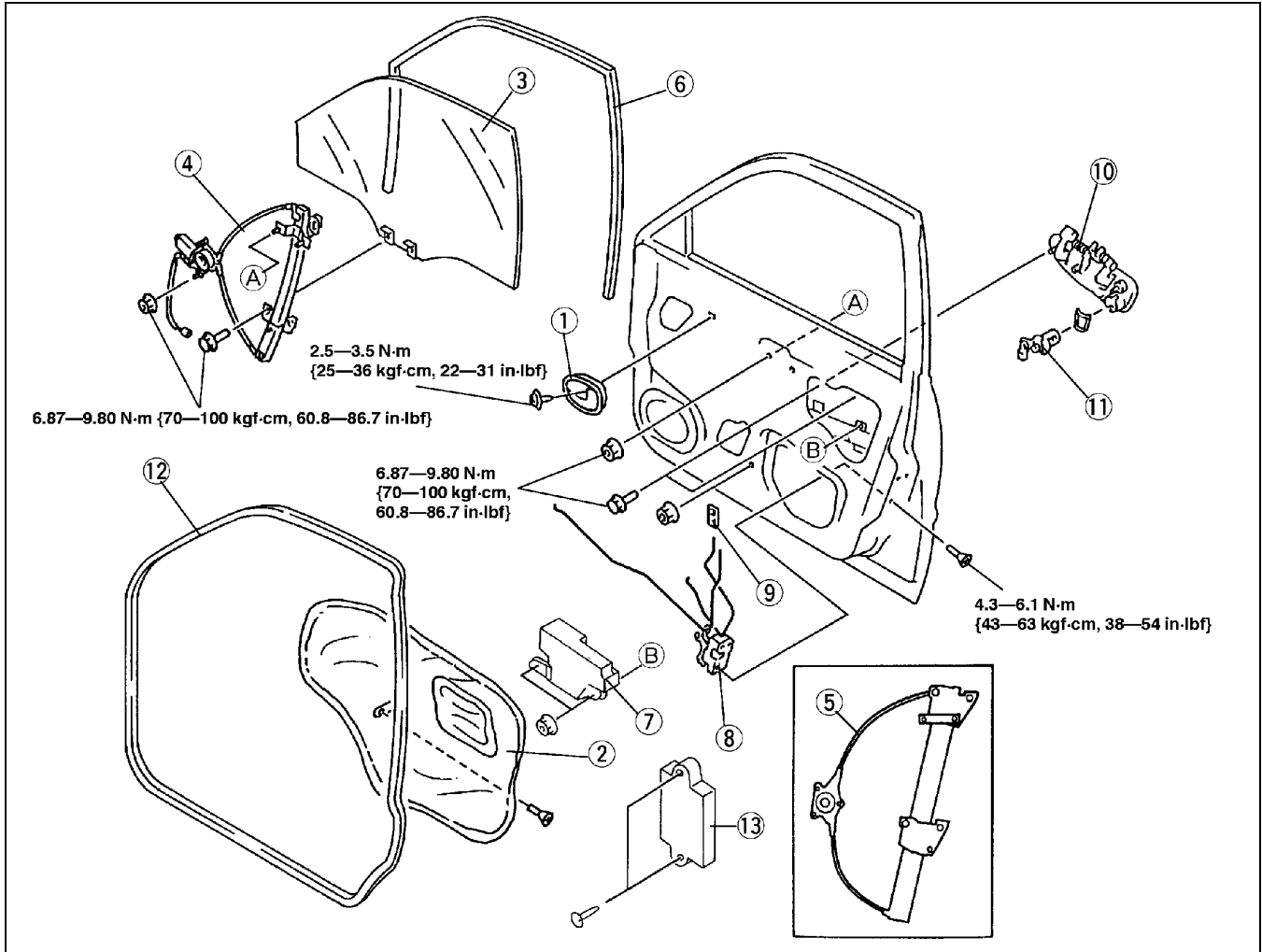

X3U911WA3

09-11

1	Inner handle
2	Door screen
3	Front door glass
4	Front power window regulator
5	Front manual window regulator
6	Glass run channel
7	Crush pad A

8	Front door lock
9	Door lock knob
10	Outer handle
11	Door key cylinder
12	Door weatherstrip
13	Crush pad B

# DOORS AND LIFTGATE

## REAR DOOR ADJUSTMENT

A3U091172010W01

1. Measure the gap and height between the rear door and the body.
  - If not as specified, loosen the door hinge installation bolts or the door lock striker installation screws, and reposition the door. (See 09-11-4 REAR DOOR REMOVAL/INSTALLATION.) (See 09-14-7 DOOR LOCK STRIKER REMOVAL/INSTALLATION.)

### Clearance

- a: 3.5—5.5 mm {0.14—0.21 in}
- b: -1.0—0.5 mm {-0.040—0.019 in}
- c: 3.0—5.0 mm {0.12—0.19 in}
- d: -1.0—1.0 mm {-0.040—0.039 in}

2. Tighten the bolts or screws.

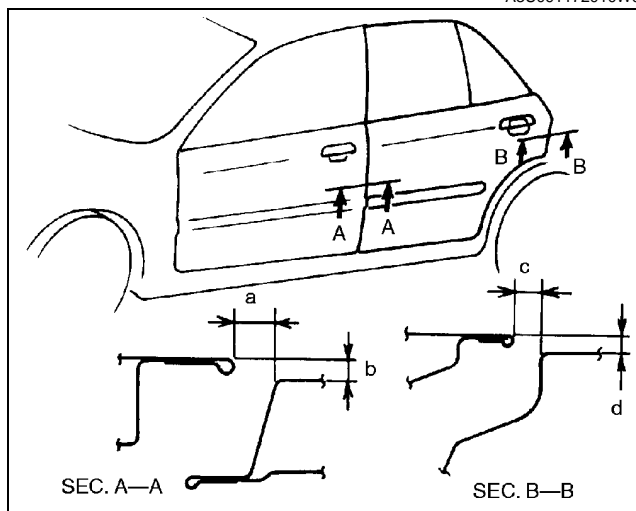

Z3U0911W004

## REAR DOOR REMOVAL/INSTALLATION

A3U091172010W02

### Warning

- Handling the side air bag sensor improperly can accidentally deploy the side air bag module, which may seriously injure you. Read AIR BAG SYSTEM SERVICE WARNINGS before working around the B-pillar areas. (See 08-10-3 AIR BAG SYSTEM SERVICE WARNINGS.)

### Note

- The side air bag sensor is located in the B-pillar.

1. Disconnect the negative battery cable.
2. To remove the checker, turn the door screen over.
3. Remove in the order indicated in the table.
4. Install in the reverse order of removal.

1	Connector (See 09-11-5 Connector Removal Note) (See 09-11-5 Connector Installation Note)
2	Checker pin
3	Rear door hinge
4	Rear door
5	Checker

5. Adjust the rear door. (See 09-11-4 REAR DOOR ADJUSTMENT.)

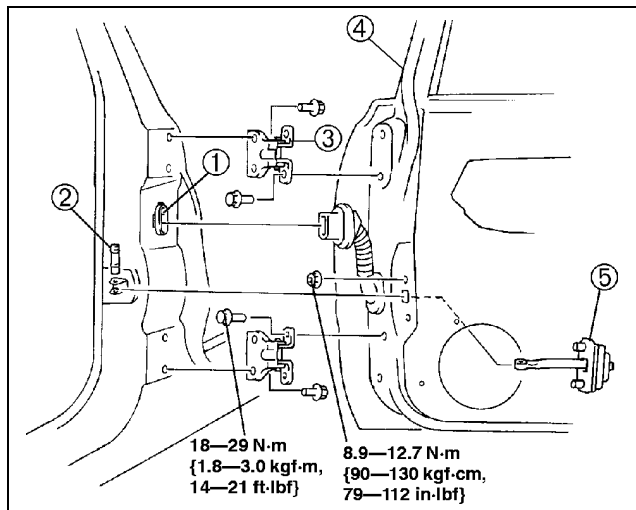

Z3U0911W003

## DOORS AND LIFTGATE

### Connector Removal Note

1. Pull the pin outward.
2. Disconnect the connector.

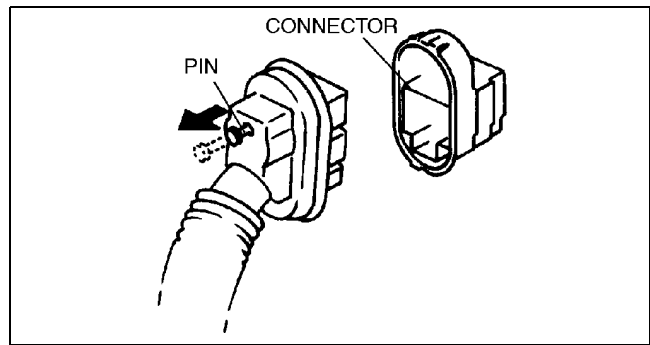

X3U911WA6

### Connector Installation Note

1. Push the pin in.
2. Connect the connector.
3. Push the pin in again.

### REAR DOOR DISASSEMBLY/ASSEMBLY

1. Open the rear door glass completely.
2. Disconnect the negative battery cable.
3. Remove the rear door trim. (See 09-17-9 REAR DOOR TRIM REMOVAL/INSTALLATION.)
4. Disassemble in the order indicated in the table.

A3U091172010W03

## DOORS AND LIFTGATE

5. Assemble in the reverse order of disassembly.

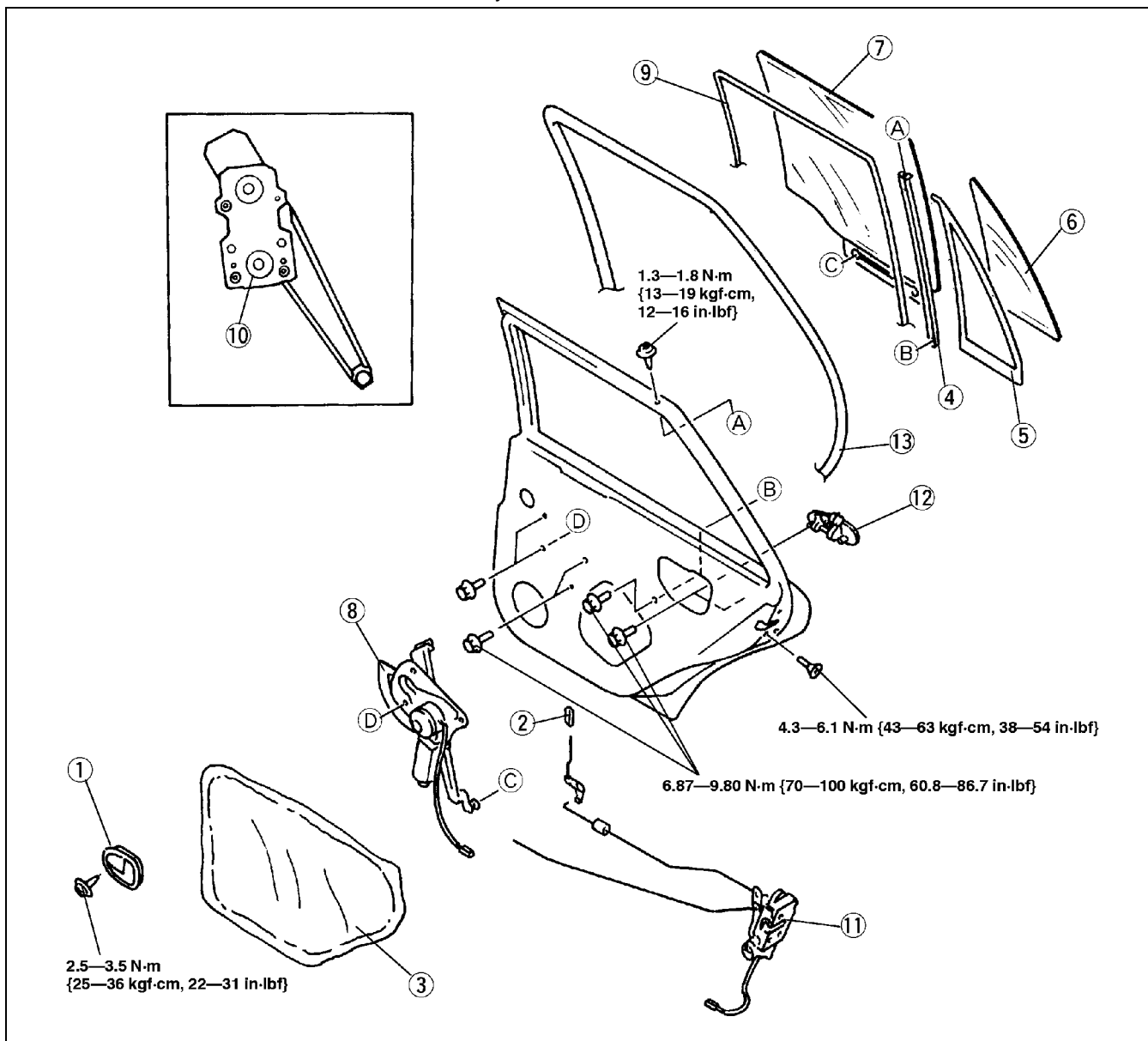

X3U911WA7

1	Inner handle
2	Door lock knob
3	Door screen
4	Glass guide
5	Door quarter window glass weatherstrip
6	Door quarter window glass
7	Rear door glass

8	Rear power window regulator
9	Glass run channel
10	Rear manual window regulator
11	Rear door lock
12	Outer handle
13	Door weatherstrip

# DOORS AND LIFTGATE

## LIFTGATE REMOVAL/INSTALLATION

A3U091162010W01

### Warning

- Removing the stay damper without supporting the liftgate can be dangerous. The liftgate may fall and injure you. Open the liftgate fully and support it before removing the stay damper.

1. Disconnect the negative battery cable.
2. Remove the headliner. (See 09-17-16 HEADLINER REMOVAL/INSTALLATION.)
3. Remove in the order indicated in the table.

1	Connector
2	Rear washer hose
3	Bolt
4	Nut
5	Liftgate

4. Install in the reverse order of removal.
5. Adjust the liftgate. (See 09-11-9 LIFTGATE ADJUSTMENT)

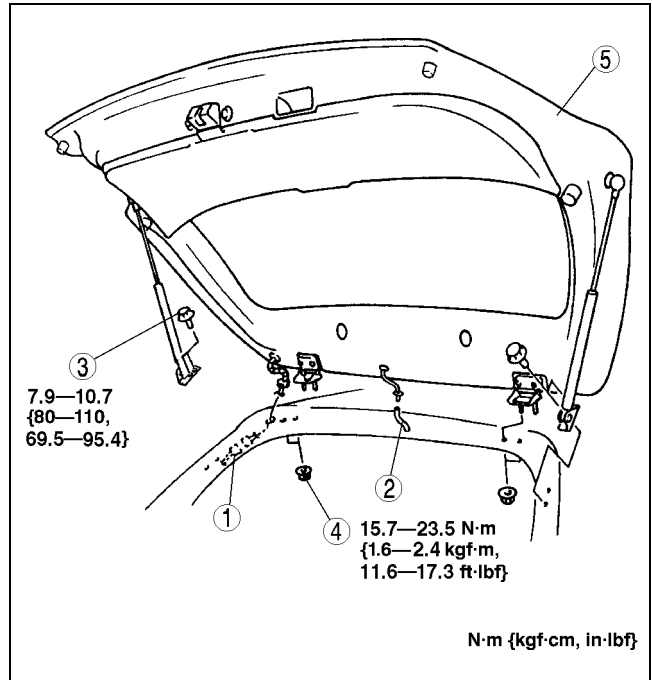

A3U0911W001

09-11

# DOORS AND LIFTGATE

A3U091162010W02

## LIFTGATE DISASSEMBLY/ASSEMBLY

1. Disconnect the negative battery cable.
2. Remove the liftgate trim.
3. Disassemble in the order indicated in the table.
4. Assemble in the reverse order of disassembly.

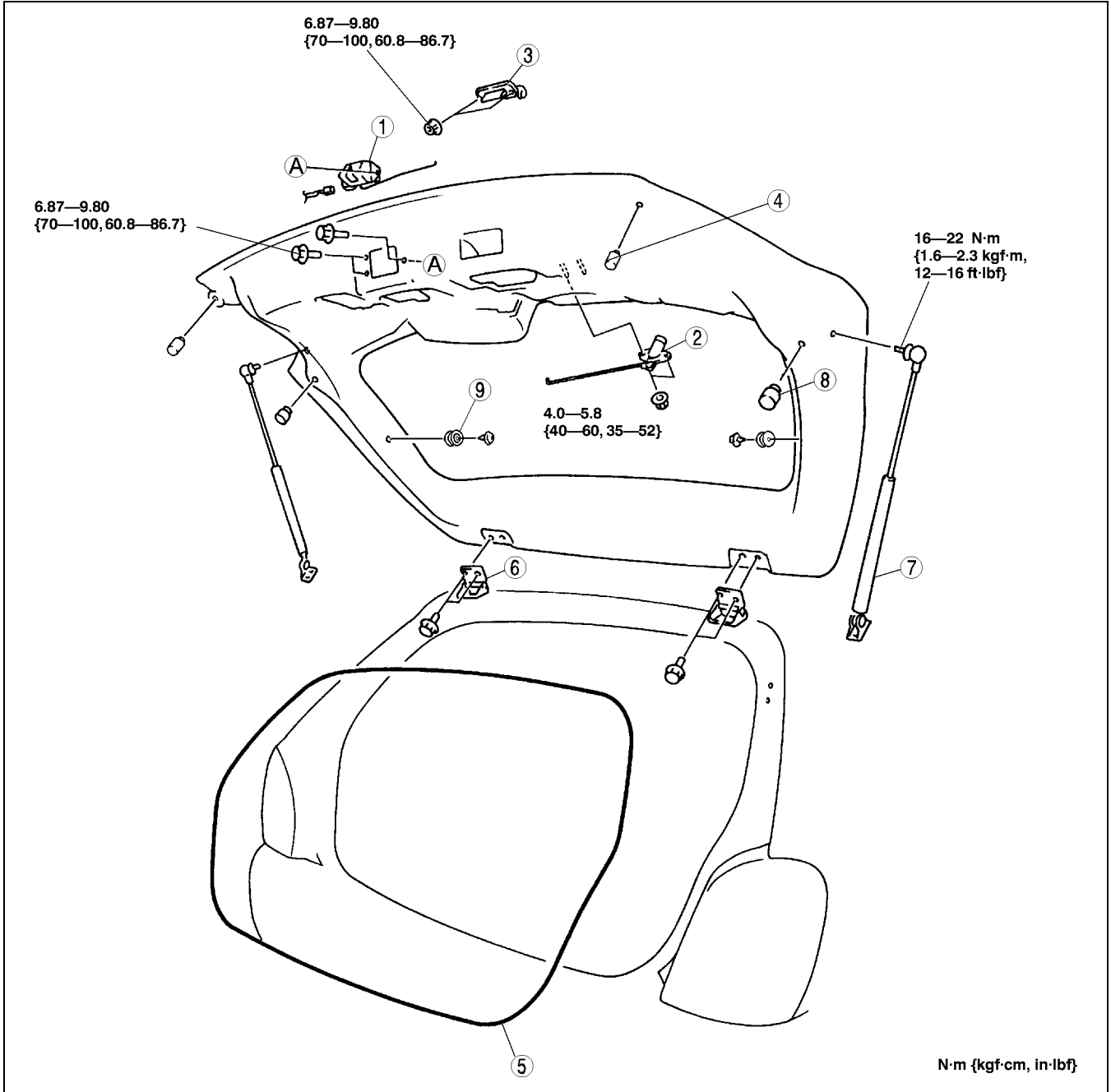

A3U0911W002

1	Liftgate lock
2	Liftgate lock cylinder
3	Liftgate outer handle
4	Stop rubber A
5	Liftgate weatherstrip

6	Liftgate hinge
7	Stay damper
8	Stop rubber B
9	Strap hanger



# DOORS AND LIFTGATE

## LIFTGATE ADJUSTMENT

A3U091162010W03

1. Measure the gap and height between the liftgate and the body.
2. To measure the distance d, measure **within 484 mm {19.1 in}** right and left from the center of the liftgate.

### Clearance

- a: 7.5—9.5 mm {0.30—0.37 in}
- b: -0.5—1.5 mm {-0.019—0.059 in}
- c: -0.7—1.7 mm {-0.027—0.066 in}
- d: 4.3—10.3 mm {0.17—0.41 in}

3. Loosen the liftgate hinge installation bolts or the liftgate striker installation screws, and reposition the liftgate.
4. Tighten the bolts or screws.

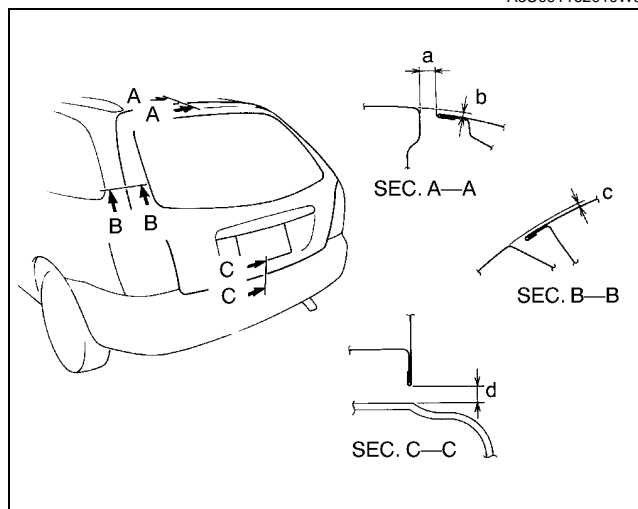

A3U0911W004

## STAY DAMPER DISPOSAL

A3U091162620W01

### Warning

- Sawing through the stay damper body can cause metal shavings and filings to fly out, causing injury to the eyes. Wear protective eye wear whenever sawing through a stay damper before discarding it.

### Note

- The gas in the stay damper is colorless, odorless, and non-toxic.

1. Lay the stay damper flat.
2. Saw through the stay damper body using a hacksaw.
3. Allow the gas to escape from the stay damper.
4. Discard the stay damper.

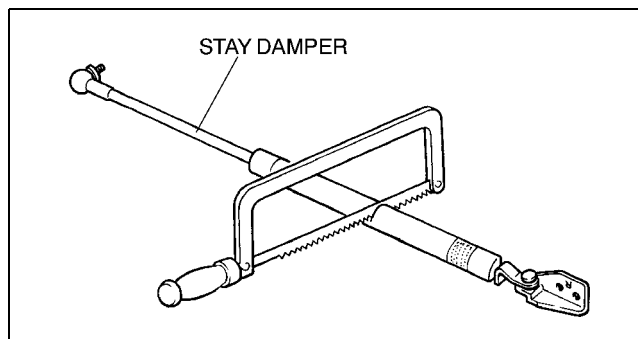

A3U0911W003

**09-12 GLASS/WINDOWS/MIRRORS**

<b>LOCATION INDEX</b> .....	09-12-2	<b>REAR WINDOW GLASS REMOVAL</b> ....	09-12-11
Power Window System .....	09-12-2	4SD .....	09-12-11
Rear Window Defroster .....	09-12-3	5HB .....	09-12-12
<b>FRONT DOOR GLASS AND</b>		<b>REAR WINDOW GLASS</b>	
<b>GUIDE REMOVAL/INSTALLATION</b> .	09-12-3	<b>INSTALLATION</b> .....	09-12-14
<b>REAR DOOR GLASS AND</b>		4SD .....	09-12-14
<b>GUIDE REMOVAL/INSTALLATION</b> ...	09-12-4	5HB .....	09-12-17
<b>POWER WINDOW MOTOR</b>		<b>WINDSHIELD REMOVAL</b> .....	09-12-19
<b>INSPECTION</b> .....	09-12-5	Not Reusing Windshield .....	09-12-19
<b>FRONT POWER WINDOW REGULATOR</b>		Reusing Windshield .....	09-12-20
<b>REMOVAL/INSTALLATION</b> .....	09-12-5	<b>WINDSHIELD INSTALLATION</b> .....	09-12-21
<b>FRONT POWER WINDOW REGULATOR</b>		<b>QUARTER WINDOW GLASS</b>	
<b>DISASSEMBLY/ASSEMBLY</b> .....	09-12-5	<b>REMOVAL</b> .....	09-12-24
Power Window Motor		<b>QUARTER WINDOW GLASS</b>	
Disassembly Note .....	09-12-6	<b>INSTALLATION</b> .....	09-12-26
<b>FRONT MANUAL WINDOW REGULATOR</b>		<b>FILAMENT INSPECTION</b> .....	09-12-27
<b>REMOVAL/INSTALLATION</b> .....	09-12-6	<b>FILAMENT REPAIR</b> .....	09-12-28
<b>REAR POWER WINDOW REGULATOR</b>		<b>REAR WINDOW DEFROSTER SWITCH</b>	
<b>REMOVAL/INSTALLATION</b> .....	09-12-6	<b>INSPECTION</b> .....	09-12-28
<b>REAR POWER WINDOW REGULATOR</b>		<b>POWER OUTSIDE MIRROR</b>	
<b>DISASSEMBLY/ASSEMBLY</b> .....	09-12-6	<b>INSPECTION</b> .....	09-12-28
Power Window Motor		<b>POWER OUTSIDE MIRROR</b>	
Disassembly Note .....	09-12-7	<b>REMOVAL/INSTALLATION</b> .....	09-12-28
Power Window Motor Assembly Note .	09-12-7	<b>MANUAL OUTSIDE MIRROR</b>	
<b>REAR MANUAL WINDOW REGULATOR</b>		<b>REMOVAL/INSTALLATION</b> .....	09-12-29
<b>REMOVAL/INSTALLATION</b> .....	09-12-7	<b>OUTSIDE MIRROR GLASS REMOVAL</b> .	09-12-29
<b>POWER WINDOW MAIN SWITCH</b>		<b>OUTSIDE MIRROR GLASS</b>	
<b>REMOVAL/INSTALLATION</b> .....	09-12-7	<b>INSTALLATION</b> .....	09-12-29
<b>POWER WINDOW MAIN SWITCH</b>		<b>POWER OUTSIDE MIRROR SWITCH</b>	
<b>INSPECTION</b> .....	09-12-8	<b>REMOVAL/INSTALLATION</b> .....	09-12-30
<b>POWER WINDOW SUBSWITCH</b>		<b>POWER OUTSIDE MIRROR SWITCH</b>	
<b>REMOVAL/PINSTALLATION</b> .....	09-12-8	<b>INSPECTION</b> .....	09-12-30
Passenger's side .....	09-12-9	<b>REARVIEW MIRROR REMOVAL</b> .....	09-12-30
Rear .....	09-12-9	<b>REARVIEW MIRROR INSTALLATION</b> ..	09-12-31
<b>POWER WINDOW SUBSWITCH</b>		<b>BASE REMOVAL</b> .....	09-12-31
<b>INSPECTION</b> .....	09-12-9	<b>BASE INSTALLATION</b> .....	09-12-31
<b>REGULATOR HANDLE REMOVAL</b> ....	09-12-10		
<b>REGULATOR HANDLE</b>			
<b>INSTALLATION</b> .....	09-12-10		

# GLASS/WINDOWS/MIRRORS

## LOCATION INDEX

A3U091201048W01

### Power Window System

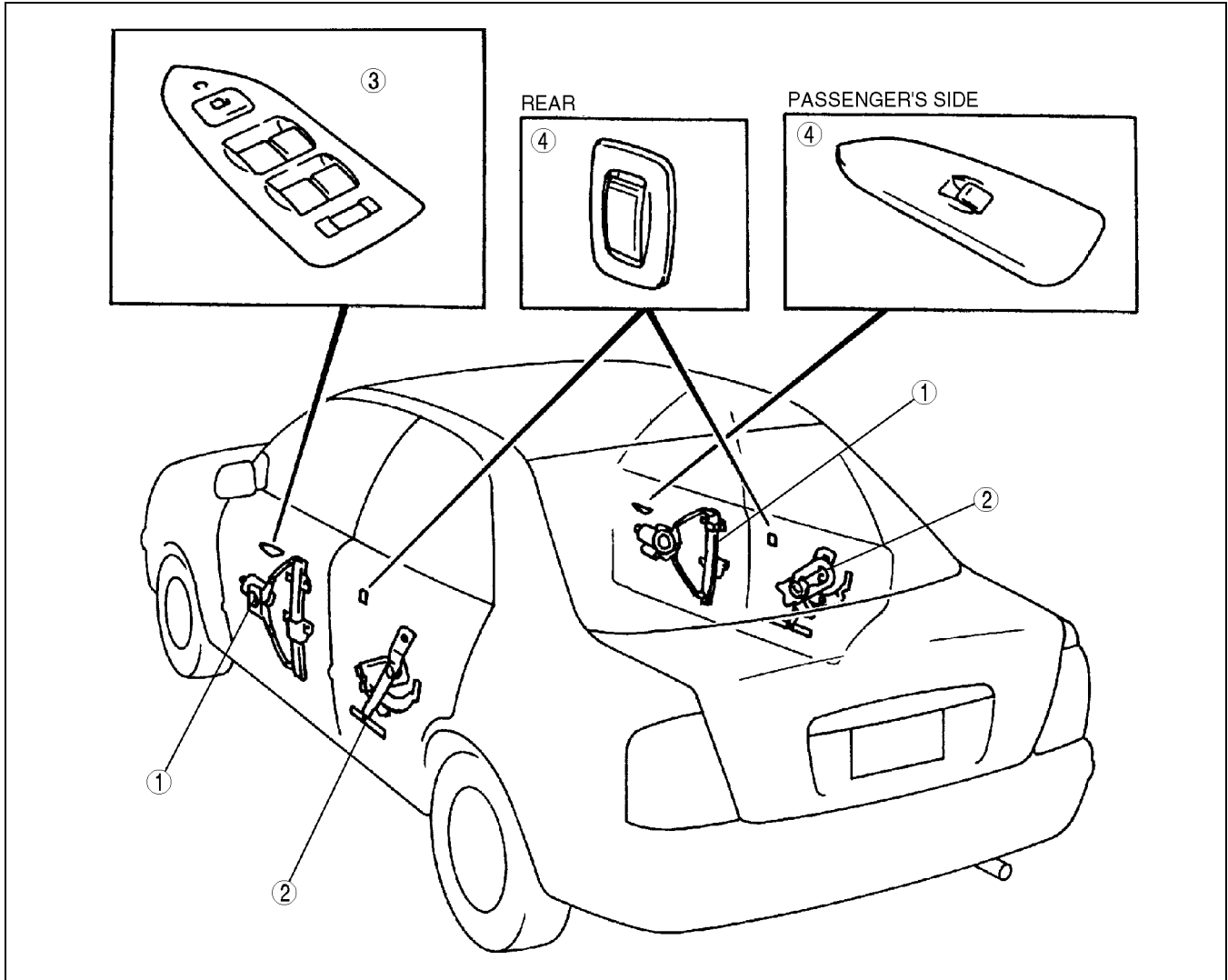

Z3U0912W015

1	<p>Front power window regulator                  (See 09-12-5 POWER WINDOW MOTOR INSPECTION)                  (See 09-12-5 FRONT POWER WINDOW REGULATOR REMOVAL/INSTALLATION)                  (See 09-12-5 FRONT POWER WINDOW REGULATOR DISASSEMBLY/ASSEMBLY)</p>
2	<p>Rear power window regulator                  (See 09-12-5 POWER WINDOW MOTOR INSPECTION)                  (See 09-12-6 REAR POWER WINDOW REGULATOR REMOVAL/INSTALLATION)                  (See 09-12-6 REAR POWER WINDOW REGULATOR DISASSEMBLY/ASSEMBLY)</p>

3	<p>Power window main switch                  (See 09-12-8 POWER WINDOW MAIN SWITCH INSPECTION)                  (See 09-12-7 POWER WINDOW MAIN SWITCH REMOVAL/INSTALLATION)</p>
4	<p>Power window subswitch                  (See 09-12-10 POWER WINDOW SUBSWITCH INSPECTION)                  (See 09-12-9 POWER WINDOW SUBSWITCH REMOVAL/INSTALLATION)</p>

## Rear Window Defroster

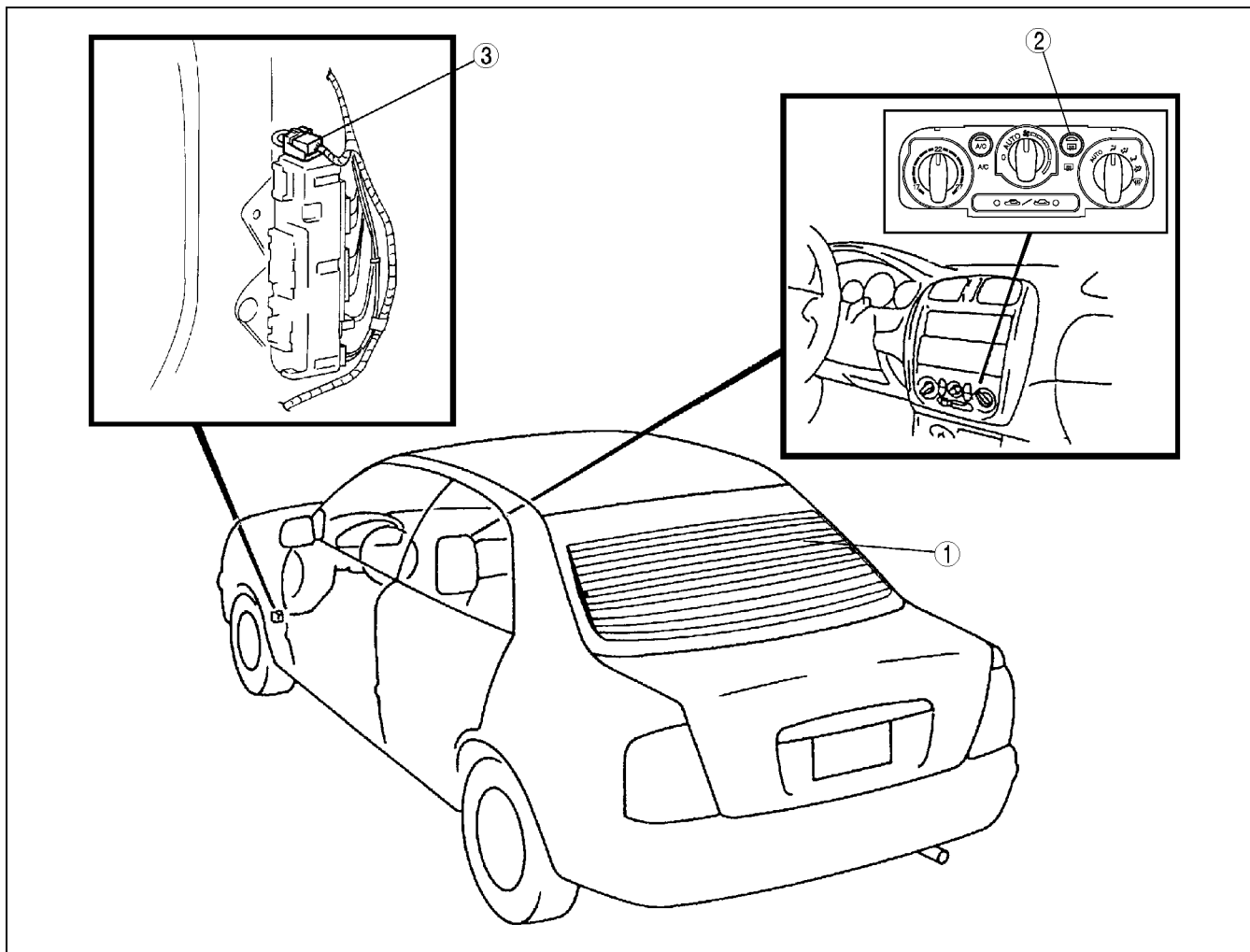

Z3U0912W016

1	Filament (See 09-12-27 FILAMENT INSPECTION) (See 09-12-28 FILAMENT REPAIR)
---	--

2	Rear window defroster switch (See 07-40-10 CLIMATE CONTROL UNIT DISASSEMBLY/ASSEMBLY) (See 07-40-11 CLIMATE CONTROL UNIT INSPECTION)
3	Rear window defroster relay (See 09-21-5 RELAY INSPECTION)

## FRONT DOOR GLASS AND GUIDE REMOVAL/INSTALLATION

A3U091258510W01

1. Lower or raise the front door glass so that the distance from the top of the front door glass at the rear end to the upper part of the front beltline molding is **130 mm {5.12 in}**.
2. Disconnect the negative battery cable.
3. Remove the front door trim. (See 09-17-9 FRONT DOOR TRIM REMOVAL/INSTALLATION.)
4. Remove the inner handle.

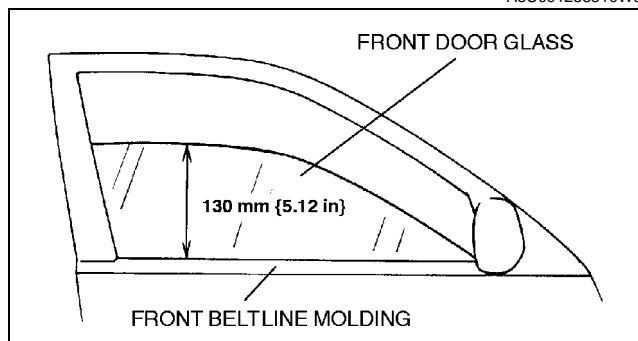

Y3U912WAJ

## GLASS/WINDOWS/MIRRORS

5. Remove in the order indicated in the table.

1	Door screen
2	Front door glass
3	Glass run channel

6. Install in the reverse order of removal.

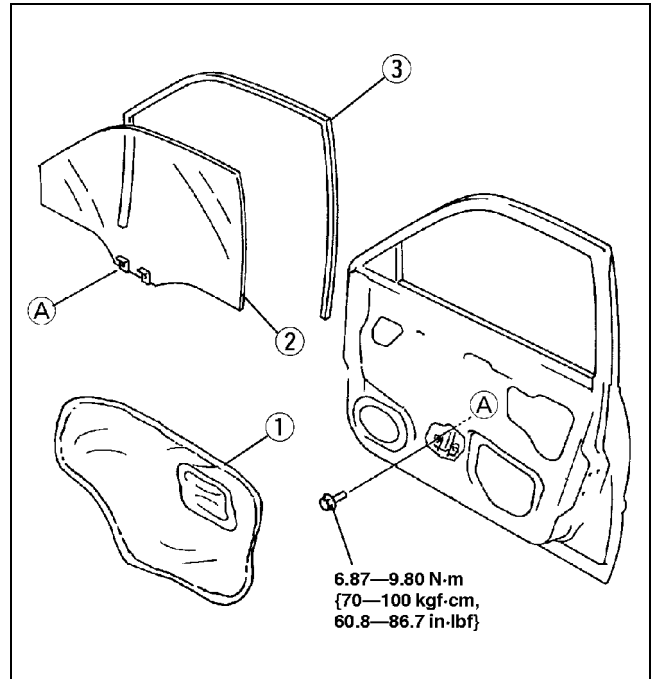

X3U912WB7

### REAR DOOR GLASS AND GUIDE REMOVAL/INSTALLATION

A3U091272510W01

1. Open the rear door glass completely.
2. Disconnect the negative battery cable.
3. Remove the rear door trim. (See 09–17–9 REAR DOOR TRIM REMOVAL/INSTALLATION.)
4. Remove the inner handle.
5. Remove in the order indicated in the table.

1	Door screen
2	Glass guide
3	Door quarter window glass weatherstrip
4	Door quarter window glass
5	Rear door glass
6	Glass run channel

6. Install in the reverse order of removal.

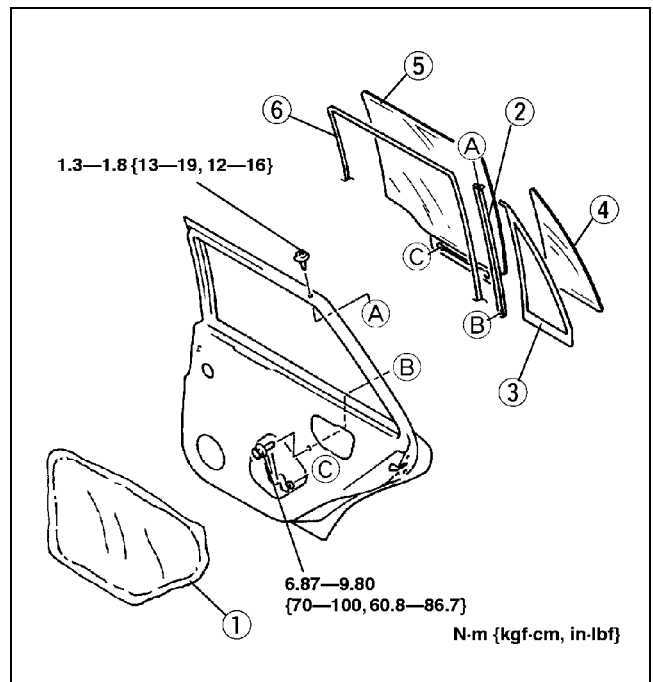

X3U912WB8

# GLASS/WINDOWS/MIRRORS

## POWER WINDOW MOTOR INSPECTION

A3U091258581W01

1. Remove the power window motor. (See 09–12–5 FRONT POWER WINDOW REGULATOR DISASSEMBLY/ASSEMBLY.) (See 09–12–6 REAR POWER WINDOW REGULATOR DISASSEMBLY/ASSEMBLY.)
2. Apply battery positive voltage to the power window motor terminals and inspect the operation of the power window motor.
  - If not as specified, replace the power window motor.

Terminal		Motor operation
A	B	
GND	B+	UP
B+	GND	DOWN

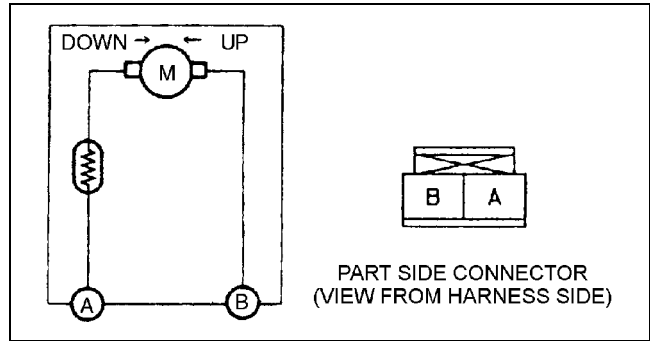

Y3U912WA0

## FRONT POWER WINDOW REGULATOR REMOVAL/INSTALLATION

A3U091258560W01

1. Disconnect the negative battery cable.
2. Remove the front door glass. (See 09–12–3 FRONT DOOR GLASS AND GUIDE REMOVAL/INSTALLATION.)
3. Disconnect the front power window regulator connector.
4. Remove the bolts and the nuts, then remove the front power window regulator.

### Tightening torque

**6.87—9.80 N·m {70—100 kgf·cm, 60.8—86.7 in·lbf}**

5. Install in the reverse order of removal.

## FRONT POWER WINDOW REGULATOR DISASSEMBLY/ASSEMBLY

A3U091258560W02

1. Disassemble in the order indicated in the table.

1	Screw
2	Power window motor (See 09–12–6 Power Window Motor Disassembly Note)
3	Frame

2. Assemble in the reverse order of disassembly.

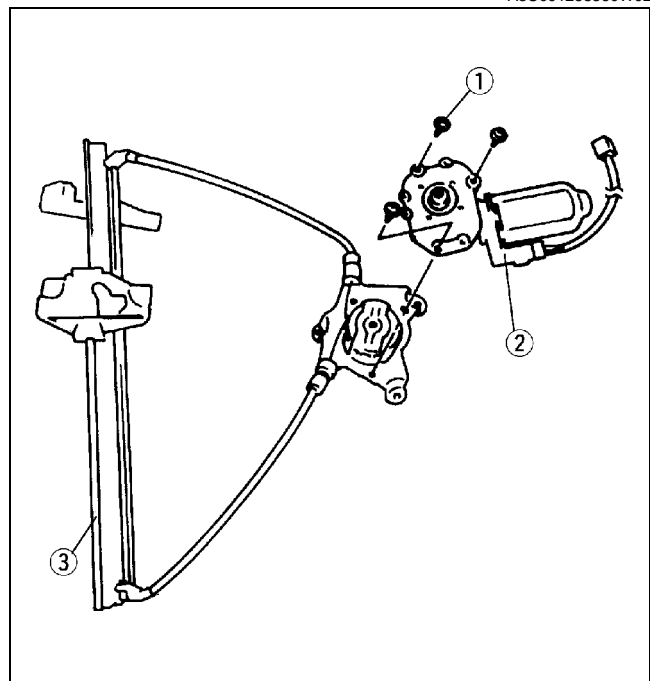

X3U912WC0

## GLASS/WINDOWS/MIRRORS

### Power Window Motor Disassembly Note

1. Hold the drum and the cable with the bracket to prevent them from being pulled out with the power window motor.

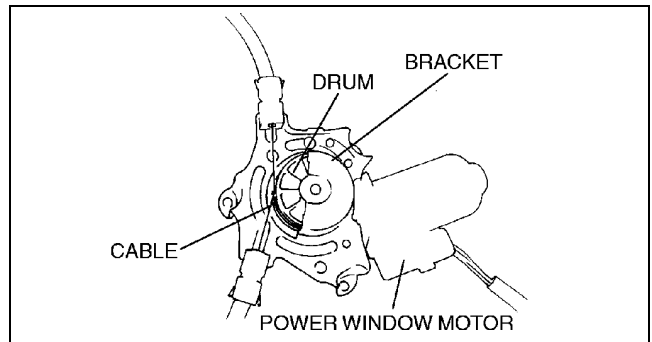

X3U912WC1

### FRONT MANUAL WINDOW REGULATOR REMOVAL/INSTALLATION

A3U091258561W01

1. Remove the front door glass. (See 09-12-3 FRONT DOOR GLASS AND GUIDE REMOVAL/INSTALLATION.)
2. Remove the bolts and the nuts, then remove the front manual window regulator.

#### Tightening torque

**6.87—9.80 N·m {70—100 kgf·cm, 60.8—86.7 in·lbf}**

3. Install in the reverse order of removal.

### REAR POWER WINDOW REGULATOR REMOVAL/INSTALLATION

A3U091272560W01

1. Disconnect the negative battery cable.
2. Remove the rear door glass. (See 09-12-4 REAR DOOR GLASS AND GUIDE REMOVAL/INSTALLATION.)
3. Disconnect the rear power window regulator.
4. Remove the bolts, then remove the rear power window regulator.

#### Tightening torque

**6.87—9.80 N·m {70—100 kgf·cm, 60.8—86.7 in·lbf}**

5. Install in the reverse order of removal.

### REAR POWER WINDOW REGULATOR DISASSEMBLY/ASSEMBLY

A3U091272560W02

1. Disassemble in the order indicated in the table.

1	Bolt
2	Power window motor (See 09-12-7 Power Window Motor Disassembly Note) (See 09-12-7 Power Window Motor Assembly Note)
3	Frame

2. Assemble in the reverse order of disassembly.

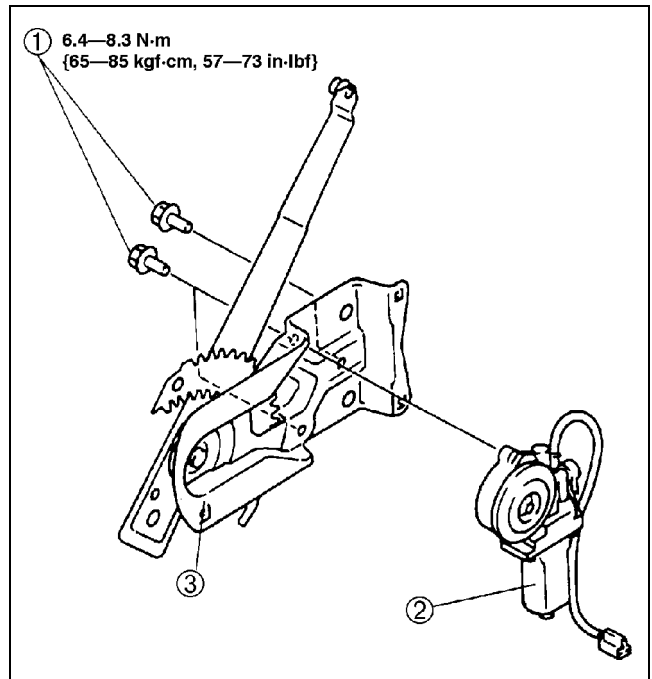

Y3U912WA1

## GLASS/WINDOWS/MIRRORS

### Power Window Motor Disassembly Note

1. Make marks on the gear and the base before disassembling the power window motor.

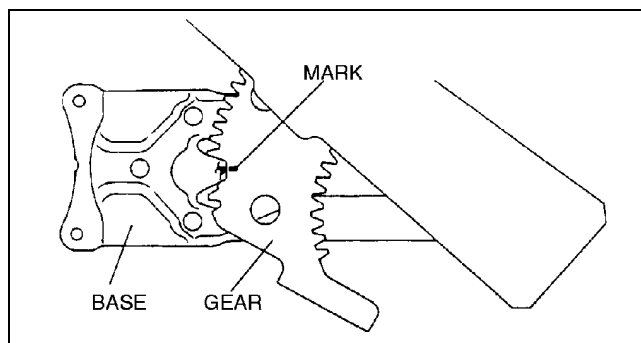

X3U912WC3

### Power Window Motor Assembly Note

1. Align the marks on the gear and the base before assembling the power window motor.

### REAR MANUAL WINDOW REGULATOR REMOVAL/INSTALLATION

A3U091272561W01

1. Remove the rear door glass. (See 09-12-4 REAR DOOR GLASS AND GUIDE REMOVAL/INSTALLATION.)
2. Remove the bolts, then remove the rear manual window regulator.

#### Tightening torque

6.87—9.80 N·m {70—100 kgf·cm, 60.8—86.7 in·lbf}

3. Install in the reverse order of removal.

### POWER WINDOW MAIN SWITCH REMOVAL/INSTALLATION

A3U091266350W01

09-12

1. Disconnect the negative battery cable.
2. Remove the driver-side front door trim. (See 09-17-9 FRONT DOOR TRIM REMOVAL/INSTALLATION.)
3. Push out the clip from the reverse side of the trim, and remove the switch panel.
4. Remove the screw, and remove the power window main switch.
5. Install in the reverse order of removal.

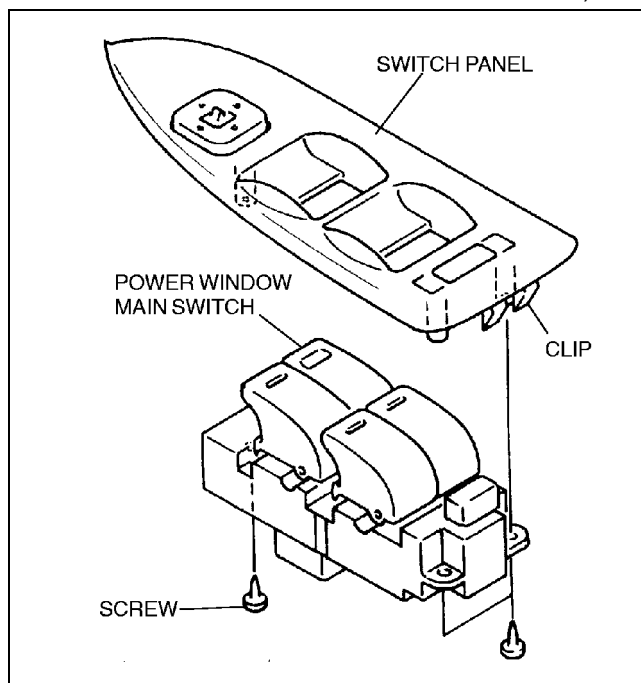

X3U912WC4



# GLASS/WINDOWS/MIRRORS

## POWER WINDOW MAIN SWITCH INSPECTION

A3U091266350W02

1. Remove the power window main switch. (See 09–12–7 POWER WINDOW MAIN SWITCH REMOVAL/INSTALLATION.)
2. When inspecting the passenger's side and the rear, turn the power-cut switch to ON.
3. Inspect for continuity between the power window main switch terminals using an ohmmeter.
  - If not as specified, replace the power window main switch.

### Driver's side

○—○ : Continuity

Switch position	Terminal			
	F	H	J	L
CLOSE	○	○—○	○	○
OFF		○—○	○—○	○—○
MANUAL OPEN AUTO OPEN	○	○—○	○	○

Z3U0912W003

### Passenger's side

○—○ : Continuity

Switch position	Terminal			
	F	H	B	D
CLOSE	○	○—○	○	○
OFF		○—○	○—○	○—○
OPEN	○	○—○	○	○

Z3U0912W004

### Rear left

○—○ : Continuity

Switch position	Terminal			
	F	H	I	K
CLOSE	○	○—○	○	○
OFF		○—○	○—○	○—○
OPEN	○	○—○	○	○

Z3U0912W005

### Rear right

○—○ : Continuity

Switch position	Terminal			
	F	H	A	C
CLOSE	○	○—○	○	○
OFF		○—○	○—○	○—○
OPEN	○	○—○	○	○

Z3U0912W006

### Power-cut switch

○—○ : Continuity

Switch position	Terminal								
	H	J	L	B	D	I	K	A	C
ON	○—○	○—○	○—○	○—○	○—○	○—○	○—○	○—○	○—○
OFF	○—○	○—○	○—○	○—○	○—○	○—○	○—○	○—○	○—○

Z3U0912W007

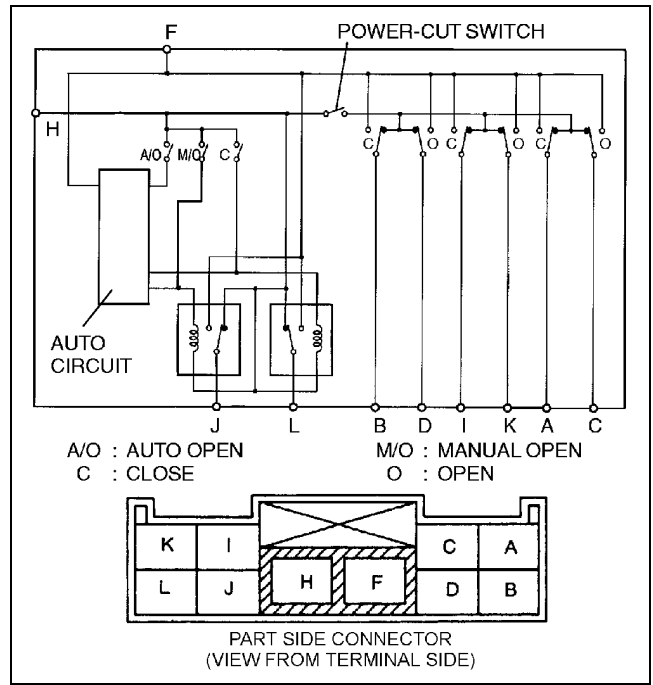

Y3U912WA2

## POWER WINDOW SUBSWITCH REMOVAL/INSTALLATION

A3U091266370W01

### Passenger's side

1. Disconnect the negative battery cable.
2. Remove the passenger-side front door trim. (See 09-17-9 FRONT DOOR TRIM REMOVAL/INSTALLATION.)
3. Push out the clip from the reverse side of the trim, and remove the switch panel.
4. Remove the screw, and remove the power window subswitch.
5. Install in the reverse order of removal.

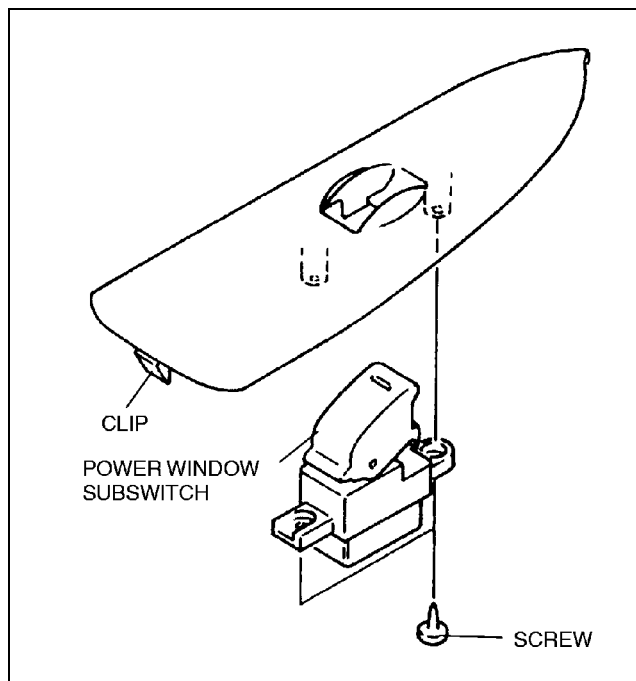

X3U912WD0

09-12

### Rear

1. Disconnect the negative battery cable.
2. Remove the tab by inserting a tape-wrapped, flathead screwdriver between the switch and the rear door trim.
3. Disconnect the connector, and remove the power window subswitch.
4. Install in the reverse order of removal.

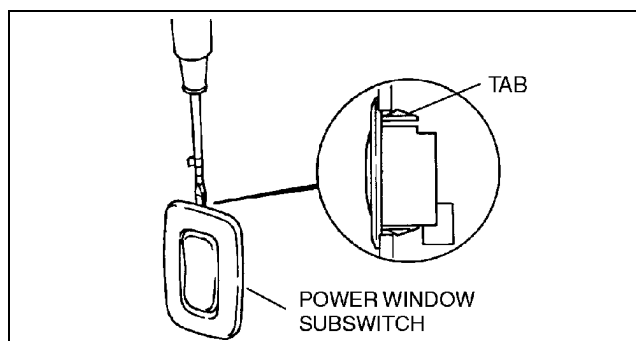

Y3U912WAK

# GLASS/WINDOWS/MIRRORS

## POWER WINDOW SUBSWITCH INSPECTION

A3U091266370W02

1. If inspecting the passenger's side, remove the switch panel.
2. If inspecting the rear, remove the power window subswitch.
3. Inspect for continuity between the power window subswitch terminals using an ohmmeter.
  - If not as specified, replace the power window subswitch.

### Passenger's side

○—○ : Continuity

Switch position	Terminal				
	A	B	C	E	F
CLOSE		○—○	○—○		○—○
OFF	○—○		○—○	○—○	
OPEN	○—○		○—○		○—○

Z3U0912W008

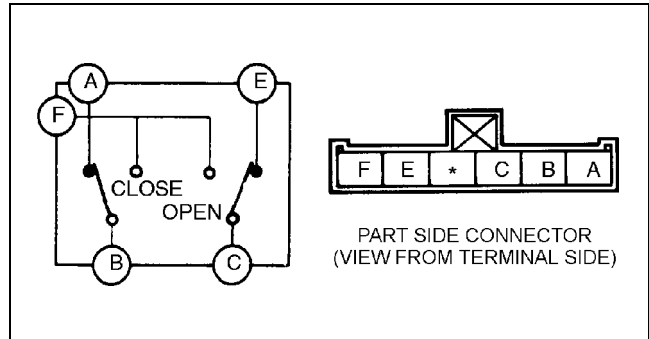

Y3U912WA3

### Rear

○—○ : Continuity

Switch position	Terminal				
	A	B	D	E	F
CLOSE	○—○		○—○	○—○	
OFF	○—○			○—○	○—○
OPEN	○—○		○—○	○—○	○—○

Z3U0912W009

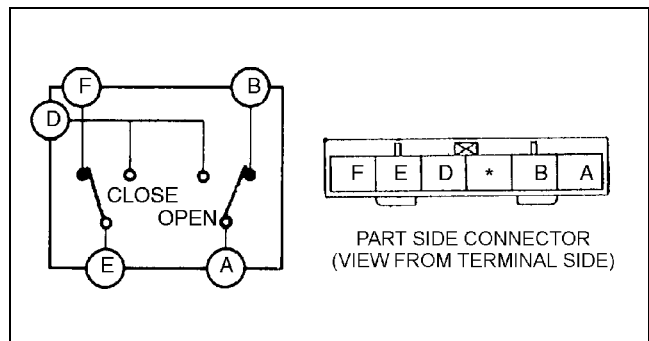

Y3U912WA4

## REGULATOR HANDLE REMOVAL

A3U091258580W01

1. Remove the regulator handle clip using a rag as shown.

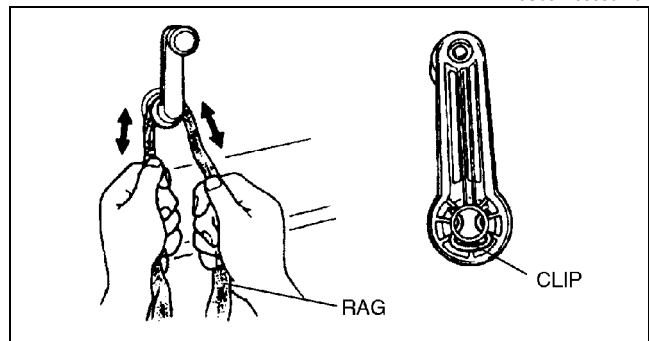

X3U912WD5

## REGULATOR HANDLE INSTALLATION

A3U091258580W02

1. Install the clip in the regulator handle.
2. Close the door glass fully and push the regulator handle on as shown.

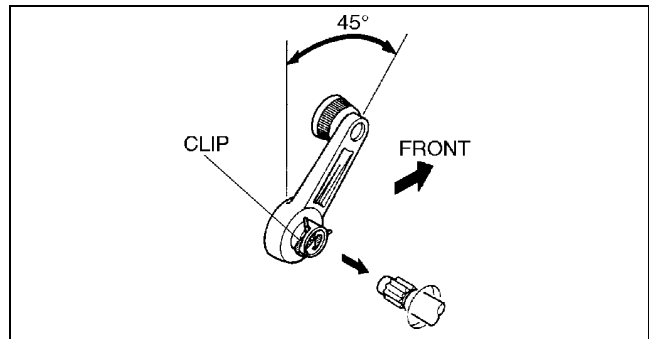

Z3U0912W002

# GLASS/WINDOWS/MIRRORS

## REAR WINDOW GLASS REMOVAL

A3U091263931W01

### 4SD

1. Remove the headliner. (See 09-17-16 HEADLINER REMOVAL/INSTALLATION.)
2. Apply protective tape along the edge of body to protect it from damage.

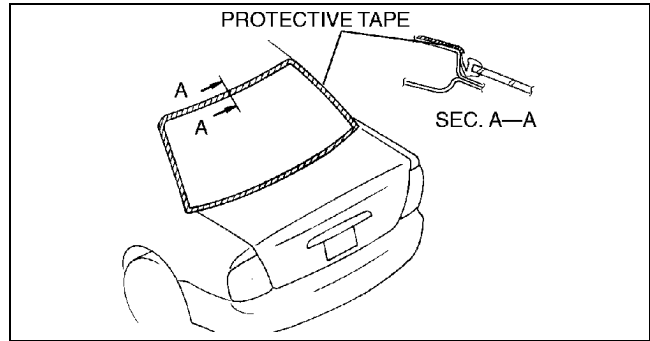

X3U912WAP

3. Remove the lip of the rear window molding using a razor.

### Warning

- Using a razor with bare hands can cause injury. Always wear gloves when using a razor.

### Note

- The rear window molding is a replacement part.

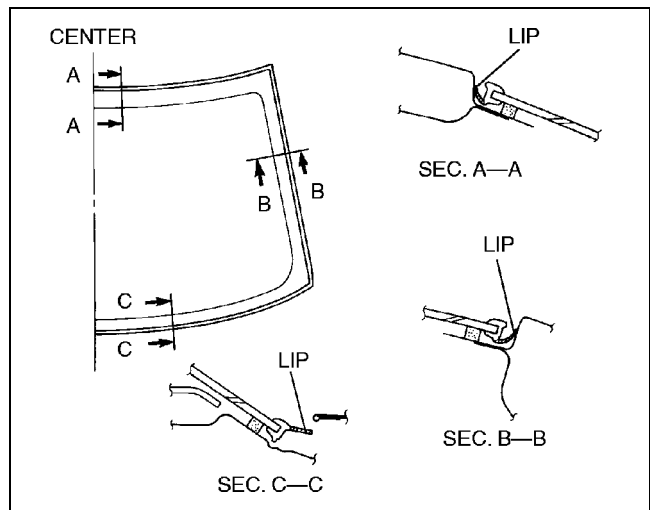

A3U0912W0101

### Not Reusing Rear Window Glass

1. Use a tool like that shown in the figure, and insert the blade into the sealant.

### Note

- For the areas of the sealant that are difficult to cut, use the **SST** (piano wire) and follow the procedures under "Reusing rear window glass".

2. Pull through the sealant around the edge of the glass.
3. Remove the glass.

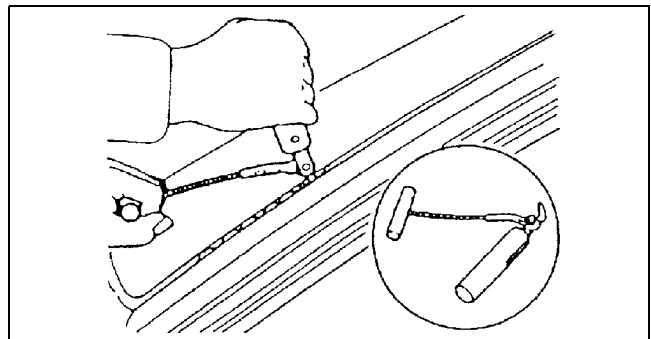

X3U912WAR

### Reusing Rear Window Glass

### Note

- Before removing the rear window glass from the body, mark the position of the rear window glass by affixing tape to the windshield and body panel.

09-12

## GLASS/WINDOWS/MIRRORS

1. Use an awl to saw through the sealant, except where there are fasteners and spacers, from the inside of the vehicle.

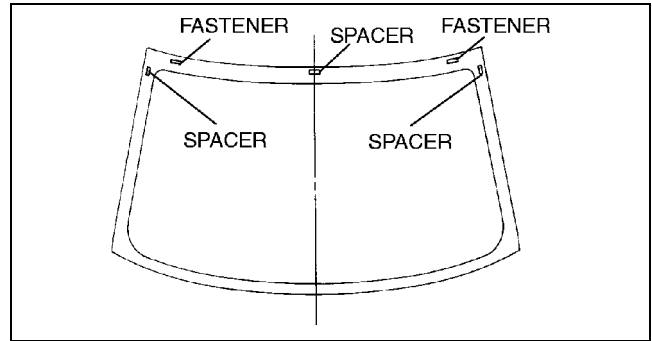

X3U912WAS

2. Pass the **SST** (piano wire) through the hole.

### Warning

- Using a **SST** (piano wire) with bare hands can cause injury. Always wear gloves when using a **SST** (piano wire).

3. Wind each end of the wire around a bar.

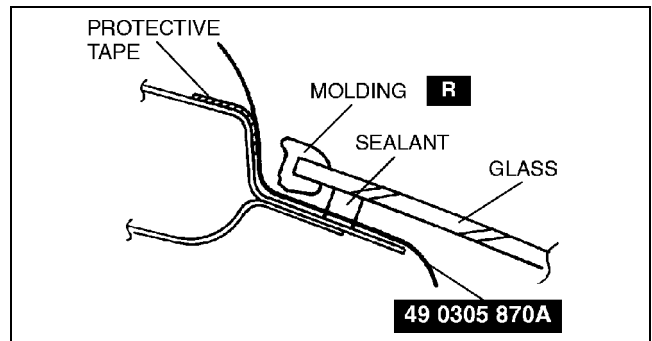

X3U912WAT

4. Working with another person, saw through the sealant around the edge of the glass, being careful not to damage the body.

### Note

- Use a long sawing action to spread the work over the whole length of the **SST** (piano wire) to prevent it from breaking.

5. Remove the rear window glass.

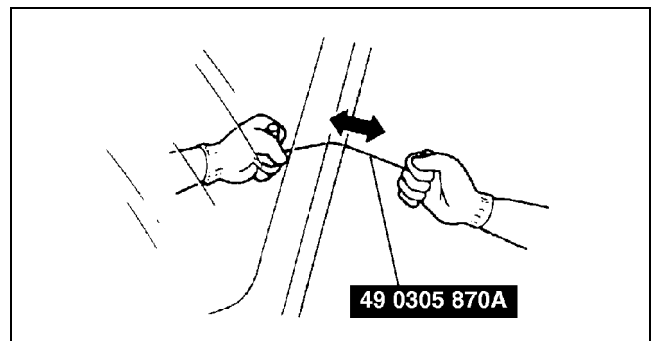

X3U912WAU

6. Remove the spacers and fasteners.
7. Remove the rear window molding from the rear window glass.

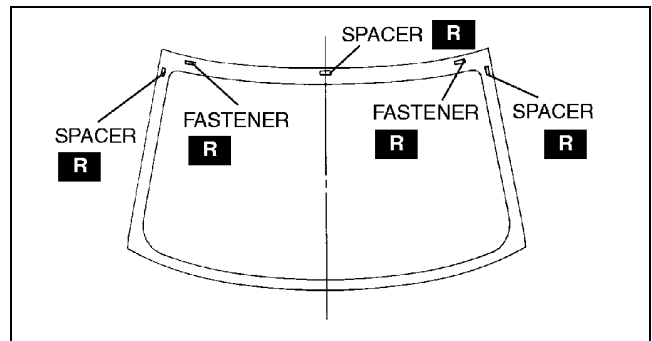

X3U912WAV

### 5HB

1. Remove the rear wiper arm and blade. (See 09–19–12 REAR WIPER ARM AND BLADE REMOVAL/INSTALLATION.)
2. Remove the liftgate trim.
3. Remove the rear spoiler.

## GLASS/WINDOWS/MIRRORS

- Apply protective tape along the edge of body to protect it from damage.

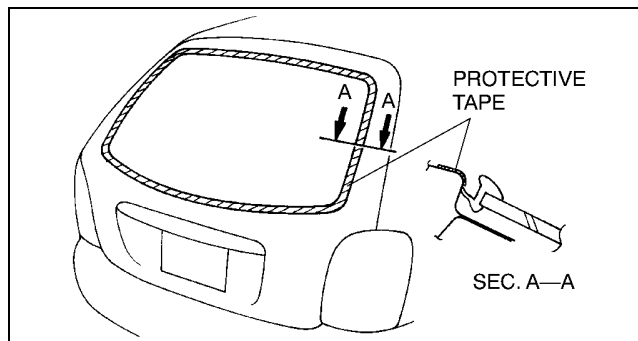

A3U0912W009

- Remove the lip of the rear window molding using a razor.

### Warning

- Using a razor with bare hands can cause injury. Always wear gloves when using a razor.

### Note

- The rear window molding is a replacement part.

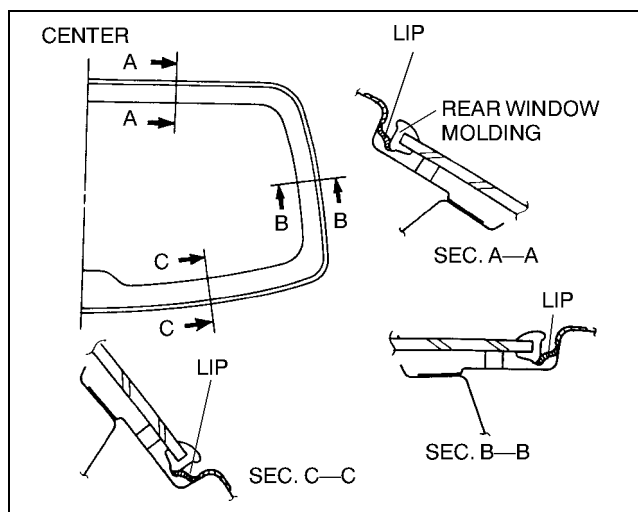

A3U0912W010

### Not Reusing Rear Window Glass

- Use a tool like that shown in the figure, and insert the blade into the sealant.

### Note

- For the areas of the sealant that are difficult to cut, use the **SST** (piano wire) and follow the procedures under "Reusing rear window glass".

- Pull through the sealant around the edge of the glass.
- Remove the glass.

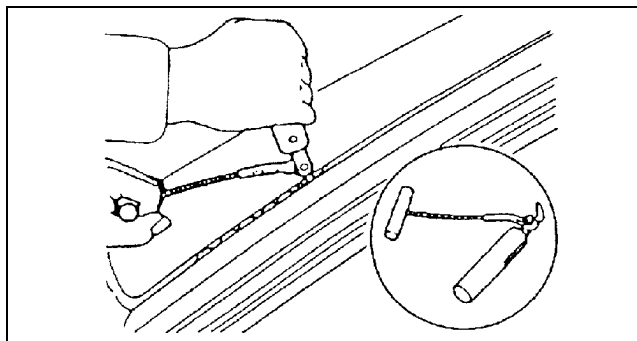

X3U912WAR

### Reusing Rear Window Glass

- Use an awl to saw through the sealant, except where there are fasteners and spacers, from the inside of the vehicle.

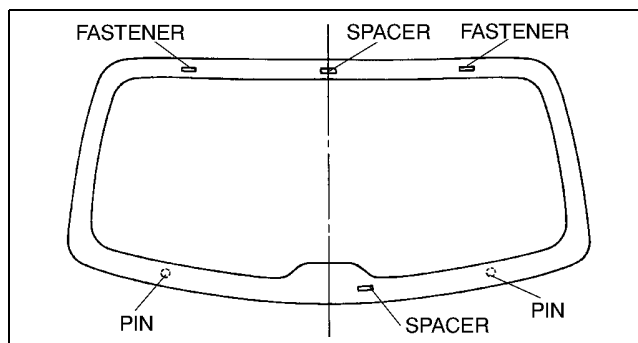

A3U0912W011

## GLASS/WINDOWS/MIRRORS

- Pass the **SST** (piano wire) through the hole.

### Warning

- Using a **SST** (piano wire) with bare hands can cause injury. Always wear gloves when using a **SST** (piano wire).

- Wind each end of the **SST** (piano wire) around a bar.

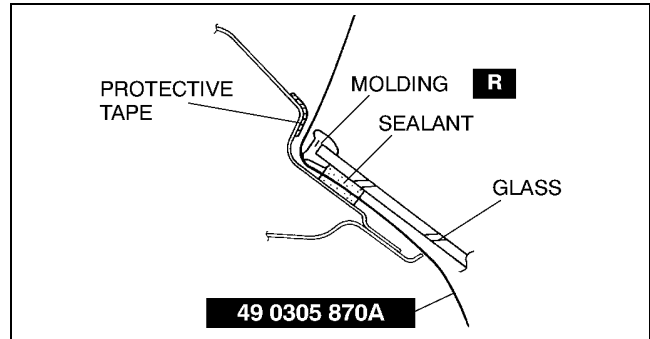

A3U0912W012

- Working with another person, saw through the sealant around the edge of the glass, being careful not to damage the body.

### Note

- Use a long sawing action to spread the work over the whole length of the **SST** (piano wire) to prevent it from breaking.

- Remove the rear window glass.

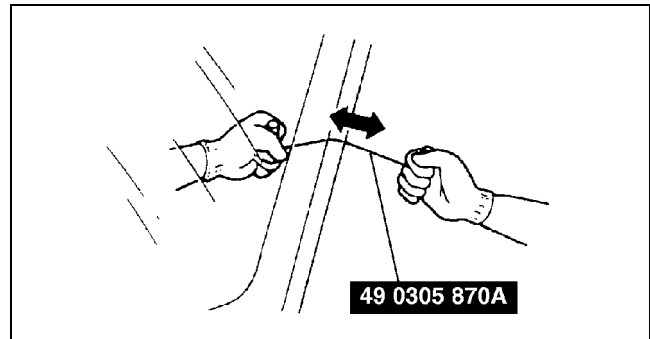

X3U912WAU

- Remove the pins, fasteners and spacers.
- Remove the rear window molding from the rear window glass.

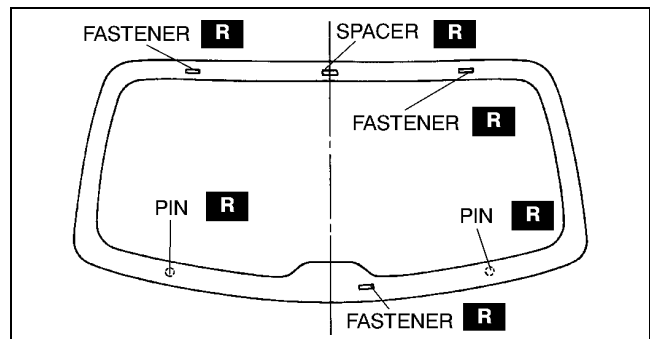

A3U0912W013

## REAR WINDOW GLASS INSTALLATION

### 4SD

A3U091263931W02

### Caution

- To prevent the sealant from cracking or the glass from being pushed out by air pressure if a door is closed, open all of the windows and leave them open until the sealant has hardened.

- Cut away the old sealant using a razor so that 1—2 mm {0.04—0.07 in} thickness of sealant remains around the circumference of the frame.
  - If all the sealant has come off in any one place, apply some primer after degreasing, and allow it **30 minutes** to dry. Then put on new sealant to create a **2 mm {0.08 in}** layer.

### Warning

- Using a razor with bare hands can cause injury. Always wear gloves when using a razor.

- Clean and degrease an **approximately 50.0 mm {1.97 in}** wide strip around the circumference of the glass and the bonding area on the body.

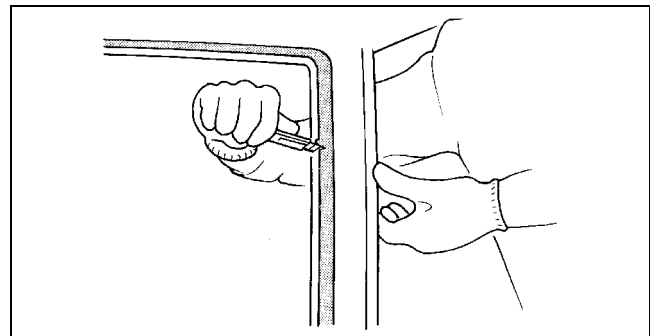

WSXWXX0003J

## GLASS/WINDOWS/MIRRORS

3. Align the lower corners of the molding and glass. (1)
4. Install the lower, starting from the outer ends and moving inward. (2)
5. Align the marking of the molding with the ceramic parting line on the glass. (3)
6. Install the sides and upper, starting from the lower edge and moving upward and inward, being careful not to pull out the corners. (4)

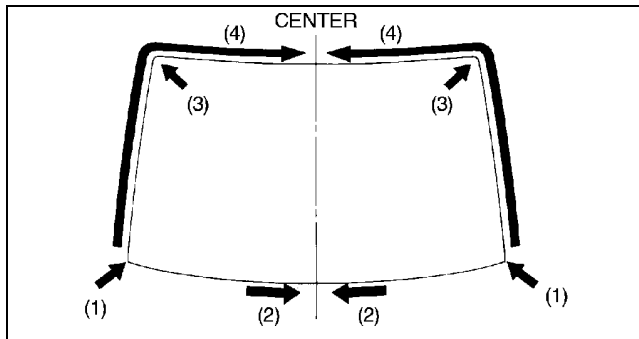

X3U912WAX

7. Securely bond a dam on the lower side of the glass **14.5 mm {0.571 in}** from the edge.
8. Install spacers into the hole.
9. Temporarily install the glass onto the body and adjust the glass-to-body clearance.
10. Make a marks on the glass directly above the V-notch of the spacers.

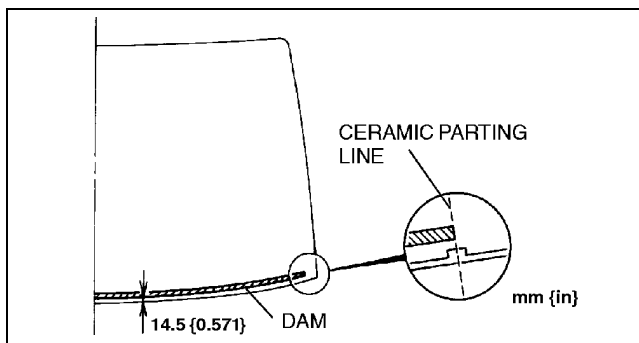

Y3U912WA5

11. Verify that the gap along the upper and side edge is **8.8 mm {0.35 in}**.
12. Remove the windshield.

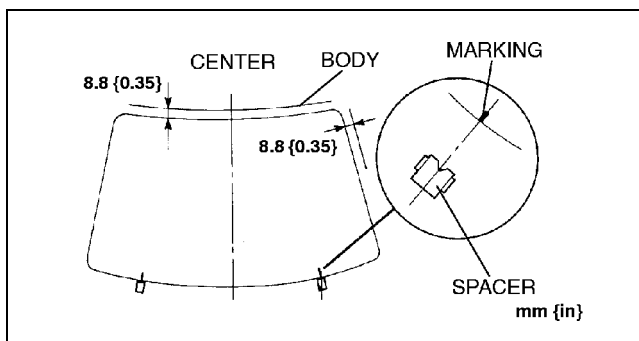

X3U912WAZ

13. Install the fasteners on the body as shown.

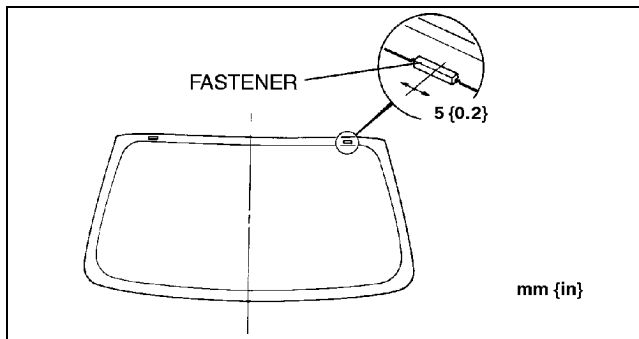

Y3U912WAH



## GLASS/WINDOWS/MIRRORS

14. Install the fasteners and spacers onto the glass as shown.

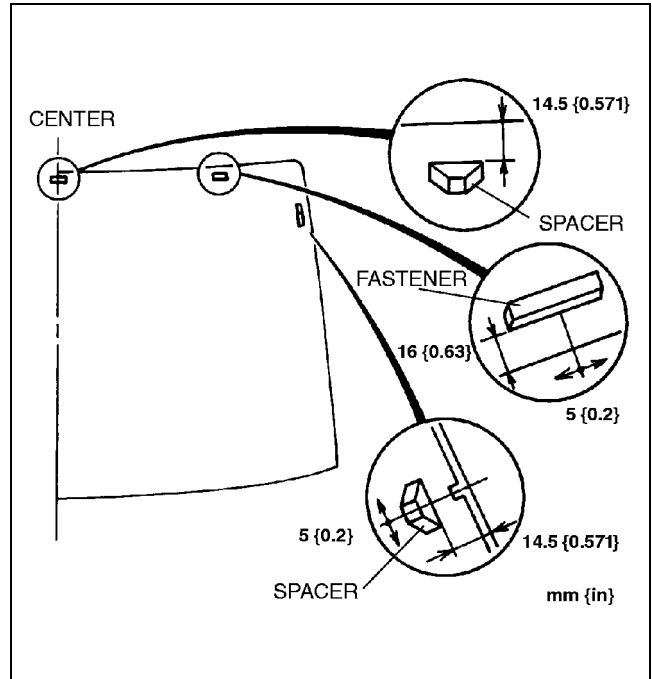

Y3U912WA6

15. Use a brush to apply primer to the bonding area of the glass and body within the region shown.

### Caution

- Keep the area free of dirt and grease, and do not touch the surface, otherwise the primer may not properly bond to the surface of the glass and body, which may cause leaks to occur.

### Note

- Use only glass primer on the glass, and body primer on the body and molding. Allow it to dry for **approximately 30 minutes**.

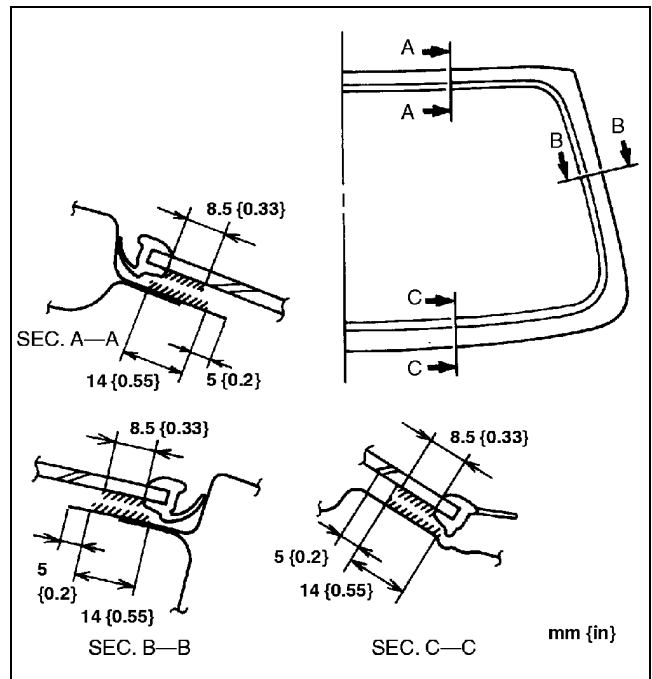

Y3U912WA7

16. Once the primer is dry, apply sealant measuring **11.0 mm {0.433 in}** in height and **5.0 mm {0.20 in}** in width around the entire circumference to fill the gap between the dam and the edge of the glass.
17. Align the marks on the glass with the V-notches in the spacers and install the glass onto the body.
18. Press firmly inward on the glass to compress the sealant.

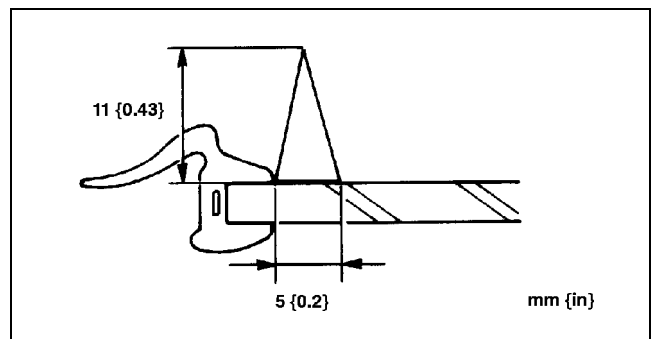

Y3U912WA8

## GLASS/WINDOWS/MIRRORS

19. Verify that the gap along the upper and side edge is **8.8 mm {0.35 in}**.

### Hardening time of sealant

Temperature	Surface hardening time	Time required until car can be put into service
5 °C {41 °F}	Approx. 1.5 h	Approx. 12 h
20 °C {68 °F}	Approx. 1 h	Approx. 4 h
35 °C {95 °F}	Approx. 10 min.	Approx. 2 h

20. Install the headliner. (See 09–17–16 HEADLINER REMOVAL/INSTALLATION.)

### 5HB

#### Caution

- To prevent the sealant from cracking or the glass from being pushed out by air pressure if a door is closed, open all of the windows and leave them open until the sealant has hardened.

1. Cut away the old sealant using a razor so that **1—2 mm {0.04—0.07 in}** thickness of sealant remains around the circumference of the frame.
  - If all the sealant has come off in any one place, apply some primer after degreasing, and allow it **30 minutes** to dry. Then put on new sealant to create a **2 mm {0.08 in}** layer.

#### Warning

- Using a razor with bare hands can cause injury. Always wear gloves when using a razor.

2. Clean and degrease the ceramic parting of the glass and the bonding area on the body.

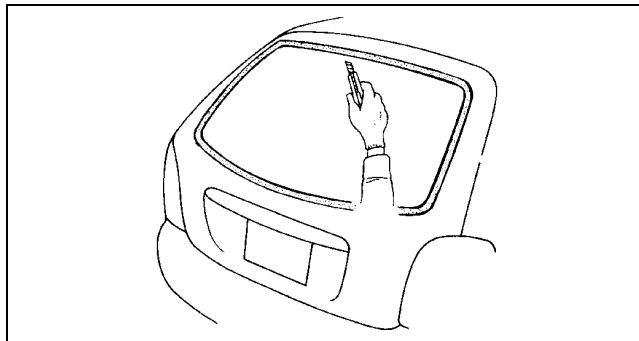

A3U0912W014

09–12

3. Align the weld joint of the molding with lower center of the glass. (1)
4. Install the molding around the entire circumference of the glass (2).

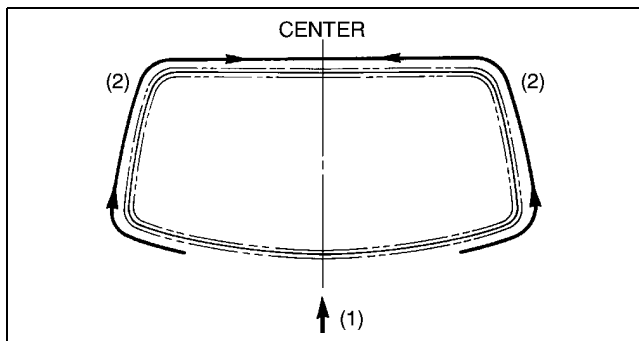

A3U0912W015

5. Install the fasteners onto the body as shown.

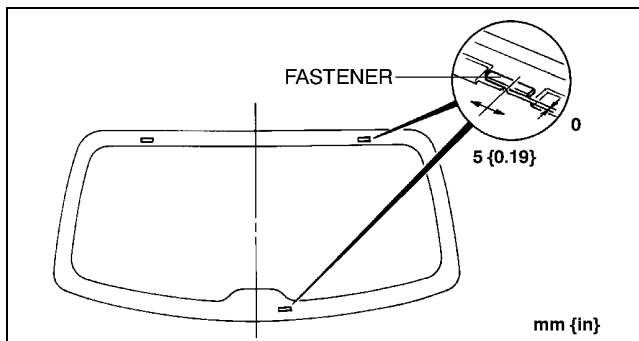

A3U0912W016

## GLASS/WINDOWS/MIRRORS

6. Install the spacer, pins and fasteners onto the glass as shown.

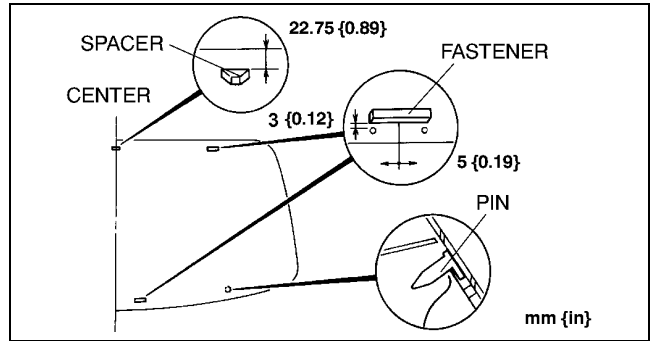

A3U0912W017

7. Use a brush to apply primer to the bonding area of the glass and body within the region shown.

### Caution

- Keep the area free of dirt and grease, and do not touch the surface, otherwise the primer may not properly bond to the surface of the glass and body, which may cause leaks to occur.

### Note

- Use only glass primer on the glass, and body primer on the body and molding. Allow it to dry for **approximately 30 minutes**.

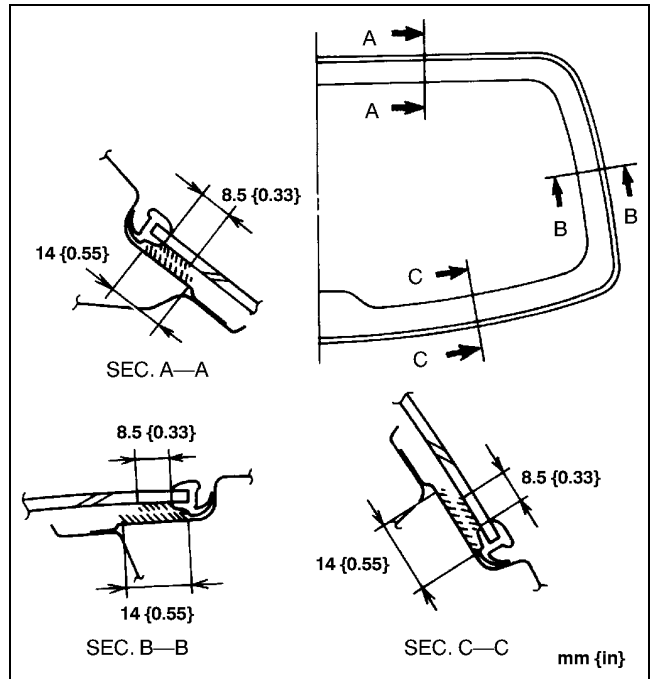

A3U0912W018

8. Once the primer is dry, apply sealant measuring **11.0 mm {0.433 in}** in height and **5.0 mm {0.20 in}** in width around the entire circumference to fill the gap between the dam and the edge of the glass.
9. Align the pins and install the glass onto the body.

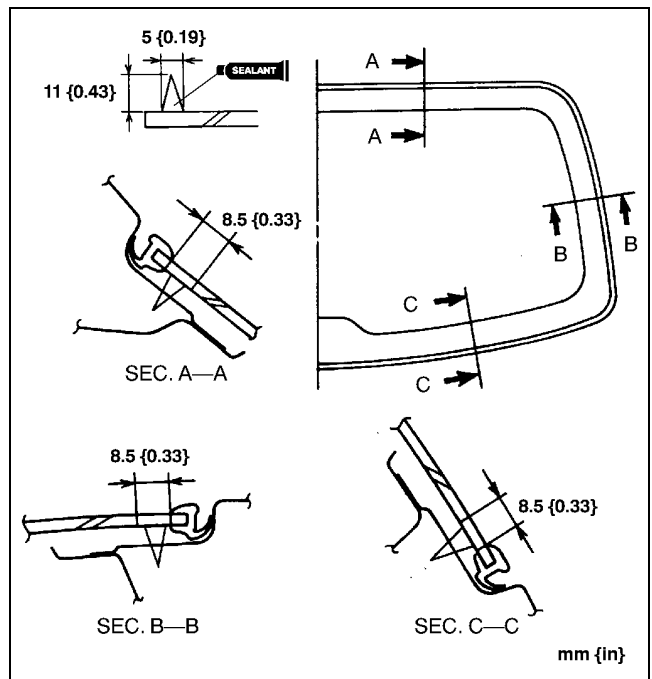

A3U0912W019

## GLASS/WINDOWS/MIRRORS

- Verify that the gap along the upper, side and lower edge is **8.8 mm {0.35 in}**.
- Press firmly inward on the glass to compress the sealant.

### Hardening time of sealant

Temperature	Surface hardening time	Time required until car can be put into service
5 °C {41 °F}	Approx. 1.5 h	Approx. 12 h
20 °C {68 °F}	Approx. 1 h	Approx. 4 h
35 °C {95 °F}	Approx. 10 min.	Approx. 2 h

- Install the rear spoiler.
- Install the liftgate trim.

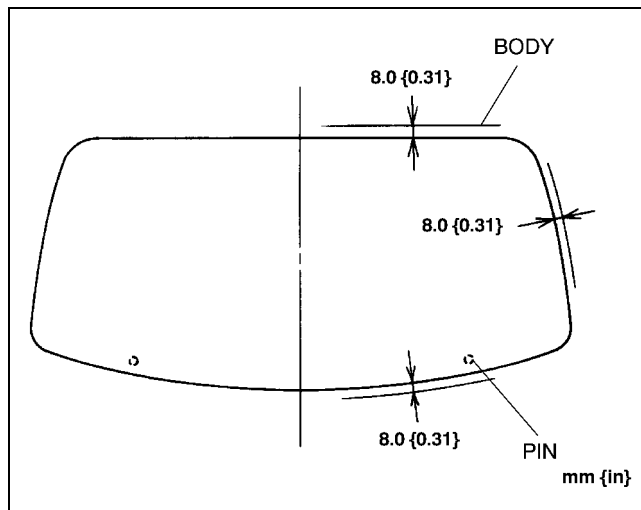

A3U0912W020

A3U091263900W01

### WINDSHIELD REMOVAL

- Remove the rearview mirror. (See 09–12–30 REARVIEW MIRROR REMOVAL.)
- Remove the cowl grille. (See 09–16–1 COWL GRILLE REMOVAL/INSTALLATION.)
- Remove the headliner. (See 09–17–16 HEADLINER REMOVAL/INSTALLATION.)
- Apply protective tape along the edge of the body to protect it from damage.
- Apply protective tape to the dashboard to protect it from damage.
- Cut the lip of the windshield molding using a razor.

#### Warning

- Using a razor with bare hands can cause injury. Always wear gloves when using a razor.

#### Note

- The windshield molding is a replacement part.

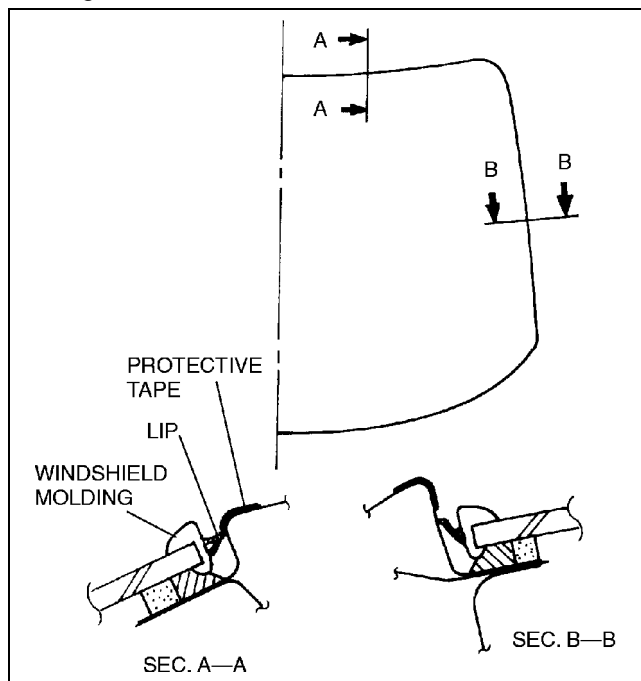

X3U912WA7

09–12

### Not Reusing Windshield

- Remove the base. (See 09–12–31 BASE REMOVAL.)

## GLASS/WINDOWS/MIRRORS

- Use a tool like that shown in the figure, and insert the blade into the sealant.

### Note

- For the areas of the sealant that are difficult to cut, use the **SST** (piano wire) and follow the procedures under "Reusing Windshield".

- Pull through the sealant around the edge of the glass.
- Remove the glass.

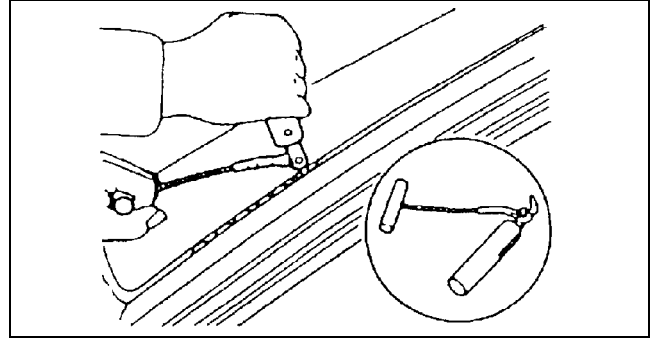

X3U912WA8

### Reusing Windshield

### Note

- Before removing the windshield from the body, mark the position of the windshield by affixing tape to the windshield and body panel.

- Make a hole through the sealant except fasteners and spacers from the inside of the vehicle using an awl.

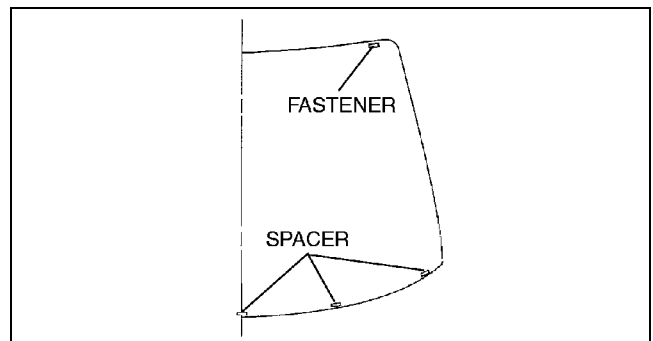

X3U912WA9

- Pass the **SST** (piano wire) through the hole.

### Warning

- Using a **SST** (piano wire) with bare hands can cause injury. Always wear gloves when using a **SST** (piano wire).

- Wind each end of the **SST** (piano wire) around a bar.

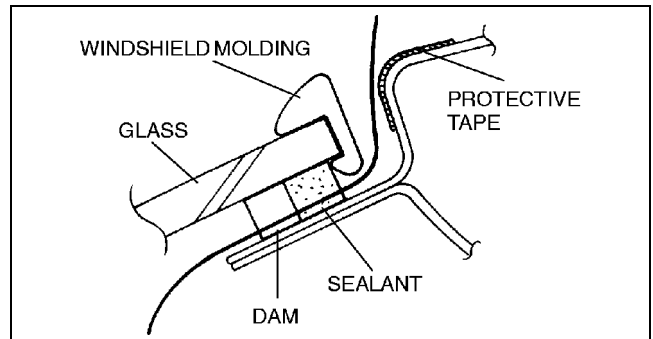

X3U912WAA

- Working with another person, saw through the sealant around the edge of the glass.

### Note

- Use a long sawing action to spread the work over the whole length of the **SST** (piano wire) to prevent it from breaking.

- Remove the windshield.

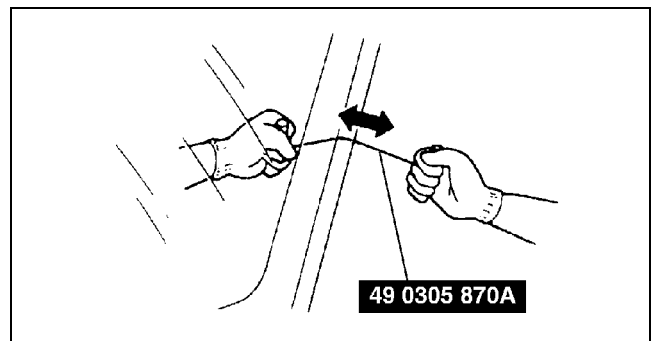

X3U912WAB

## GLASS/WINDOWS/MIRRORS

6. Remove the dam from the windshield.
7. Remove the fasteners.
8. Remove spacers A and B.

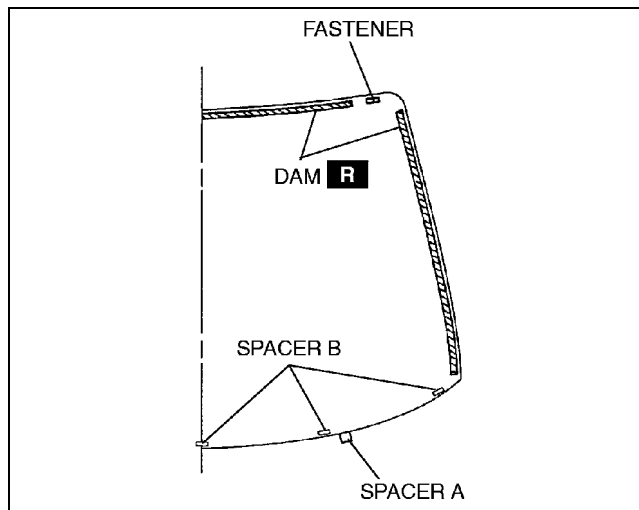

Z3U0912W011

### WINDSHIELD INSTALLATION

A3U091263900W02

#### Caution

- To prevent the sealant from cracking or the glass from being pushed out by air pressure if a door is closed, open all of the windows and leave them open until the sealant has hardened.

1. Cut away the old sealant using a razor so that **1—2 mm {0.04—0.07 in}** thickness of sealant remains around the circumference of the frame.
  - If all the sealant has come off in any one place, apply some primer after degreasing, and allow it **30 minutes** to dry. Then put on new sealant to create **2 mm {0.08 in}** layer.

#### Warning

- Using a razor with bare hands can cause injury. Always wear gloves when using a razor.

2. Clean and degrease an **approximately 50.0 mm {1.97 in}** wide strip around the circumference of the glass and the bonding area on the body.

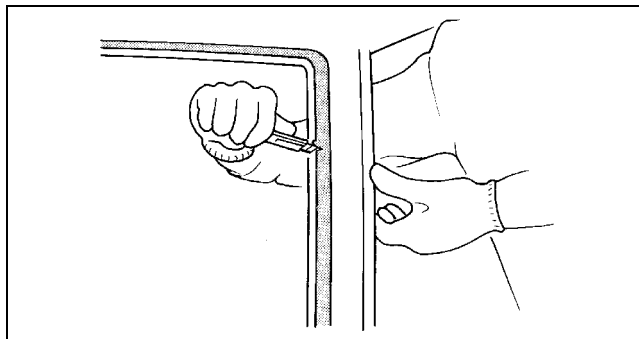

WSXWX0003J

3. Securely bond a dam along the circumference of the glass **8.0 mm {0.31 in}** from the edge.

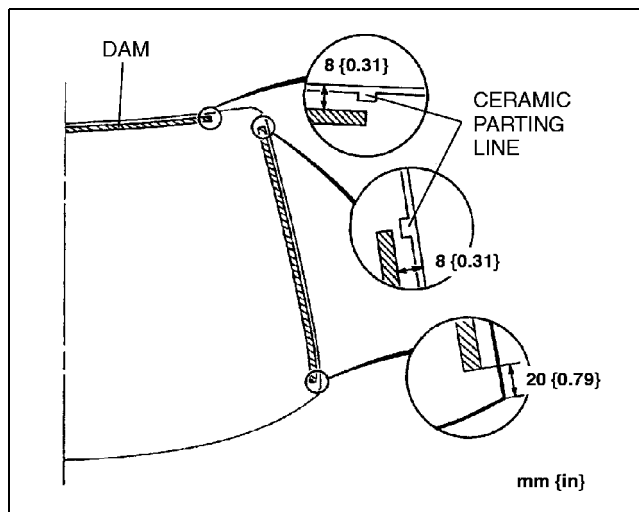

Z3U0912W012

# GLASS/WINDOWS/MIRRORS

4. Install the spacers B on the glass as shown.

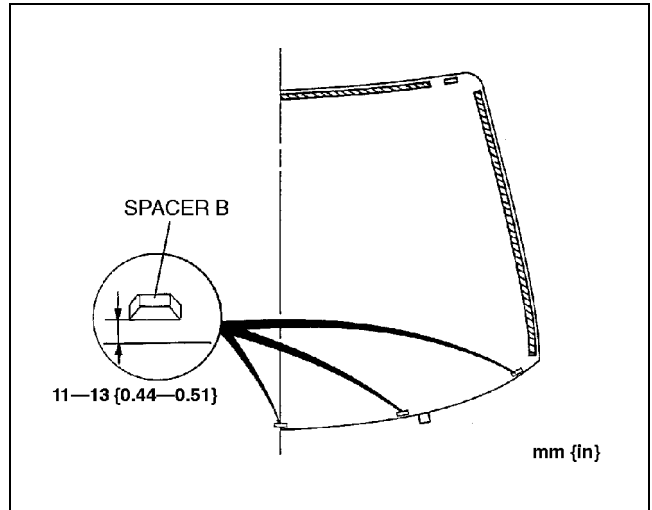

Z3U0912W013

5. Install spacers A into the hole.
6. Temporarily install the glass onto the body and adjust the glass-to-body clearance.
7. Make a mark on the glass directly above the V-notch of spacers A.
8. Verify that the gap along the upper edge is **7.3 mm {0.29 in}**, and that the side edge is **6.8 mm {0.27 in}**.
9. Remove the windshield.

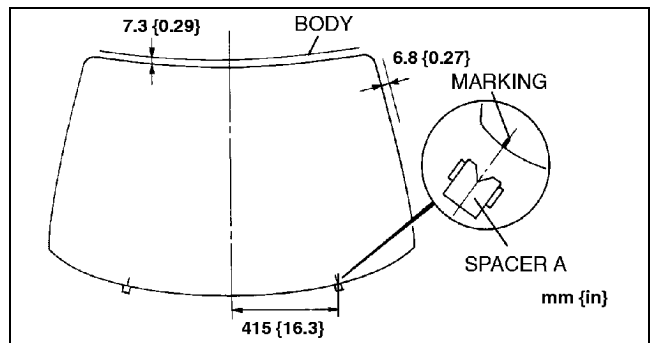

X3U912WAG

10. Install the fasteners on the glass marks as shown.

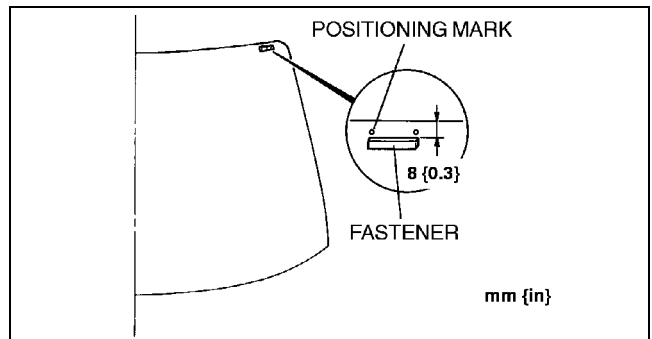

Y3U912WAA

11. Install the fasteners on the body as shown.

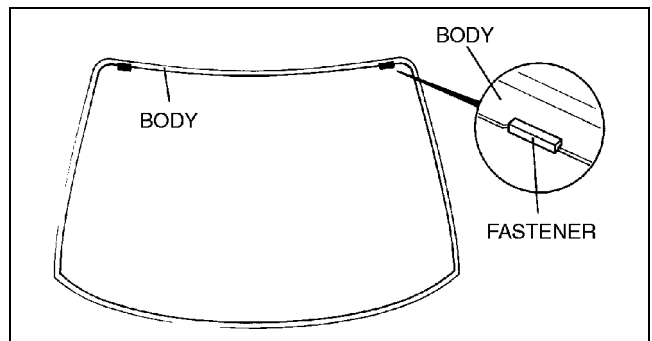

X3U912WAH

## GLASS/WINDOWS/MIRRORS

12. Use a brush to apply primer to the bonding area of the glass, the body, and the molding within the area shown.

**Caution**

- **Keep the area free of dirt and grease, and do not touch the surface, otherwise the primer may not properly bond to the surface of the glass and body, which may cause leaks to occur.**

**Note**

- Use only glass primer on the glass, and body primer on the body and the molding. Allow it to dry for **approximately 30 minutes**.

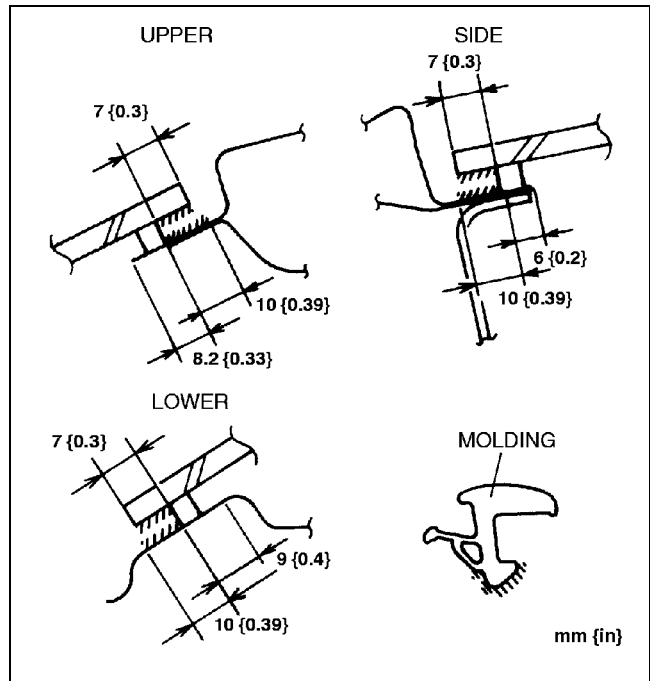

Y3U912WAB

13. Once the primer is dry, apply sealant around the entire circumference to fill the gap between the dam and the edge of the glass measuring **11.0 mm {0.433 in}** high and **5.0 mm {0.20 in}** wide.
14. Align the glass marks with the V-notches in the spacers and install the glass onto the body.
15. Press firmly inward on the glass to compress the sealant.

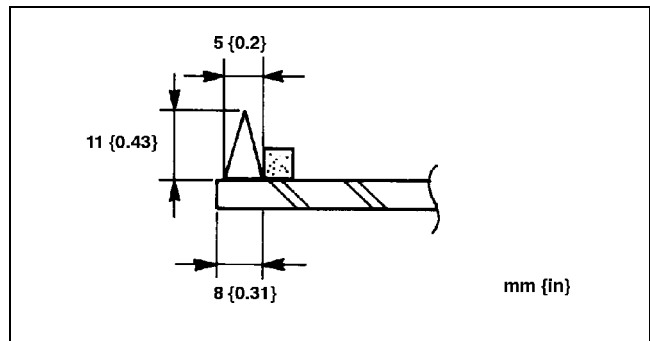

Y3U912WAC

16. Verify that the gap along the upper edge is **7.3 mm {0.29 in}** and side edge is **6.8 mm {0.27 in}**.

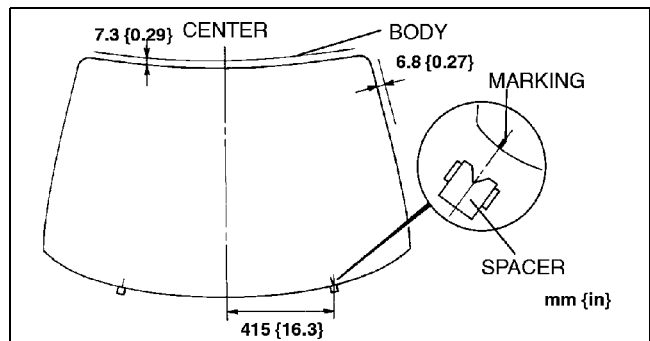

X3U912WAL

17. Use a scraper to smooth away any sealant that oozes out. Add more sealant to any points of poor contact. Adjust the sealant as shown if necessary.

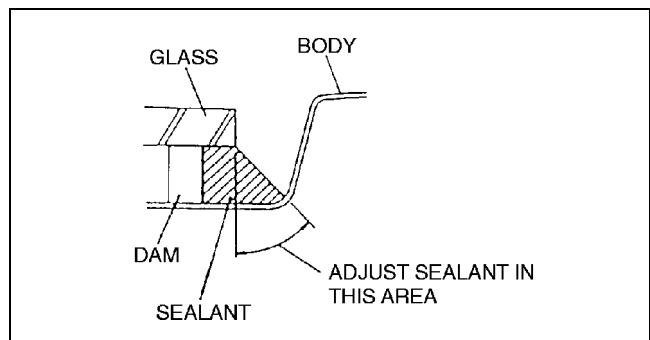

X3U912WAM



## GLASS/WINDOWS/MIRRORS

18. Before the surface of the sealant has hardened, install the windshield molding.

### Hardening time of sealant

Temperature	Surface hardening time	Time required until car can be put into service
5 °C {41 °F}	Approx. 1.5 h	Approx. 12 h
20 °C {68 °F}	Approx. 1 h	Approx. 4 h
35 °C {95 °F}	Approx. 10 min.	Approx. 2 h

19. Align the marking on the molding with the inner side of the body groove. (1)
20. Install the upper edge starting from the outer ends and moving inward. (2)
21. Install the corners. (3)
22. Install the windshield molding installation clips to the cowl grille hole. (4)
23. Install the sides, starting from the upper edge and moving downward, being careful not to pull out the corners. (5)
24. Use isopropyl alcohol to remove any excess sealant.
25. Install the headliner. (See 09-17-16 HEADLINER REMOVAL/INSTALLATION.)
26. Install the cowl grille. (See 09-16-1 COWL GRILLE REMOVAL/INSTALLATION.)
27. Install the base. (See 09-12-31 BASE INSTALLATION.)
28. Install the rearview mirror. (See 09-12-31 REARVIEW MIRROR INSTALLATION.)

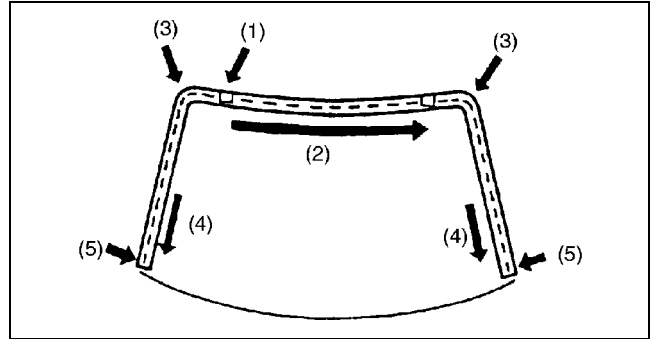

X3U912WAN

### QUARTER WINDOW GLASS REMOVAL

1. Remove the C-pillar trim. (See 09-17-11 C-PILLAR TRIM REMOVAL/INSTALLATION.)
2. Apply protective tape along the edge of body and quarter window glass.

A3U091262580W01

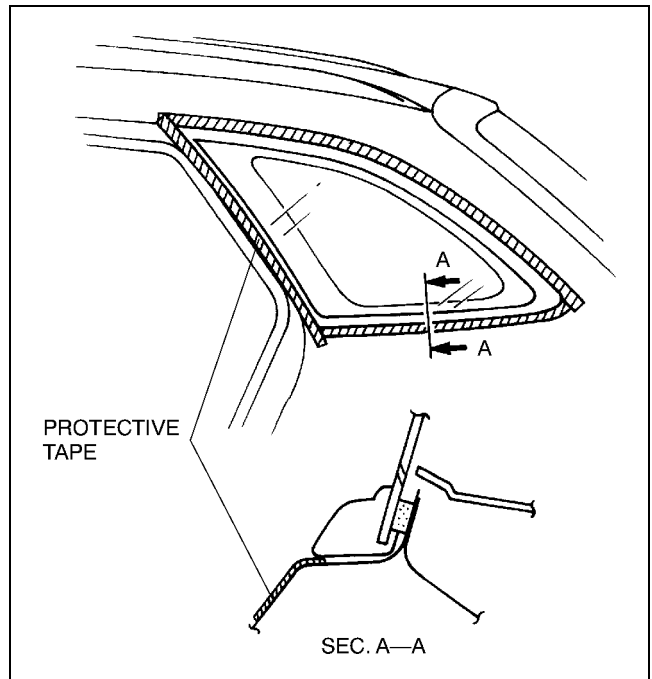

A3U0912W001

## GLASS/WINDOWS/MIRRORS

3. Make a hole through the sealant except fastener, pin and clip from the inside of the vehicle using an awl.

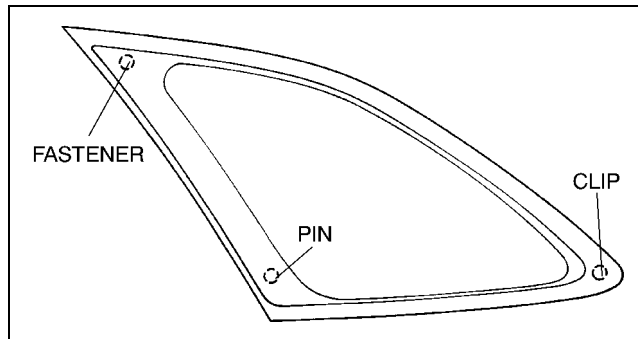

A3U0912W002

4. Pass the **SST** (piano wire) through the hole.

**Warning**

- Using a **SST** (piano wire) with bare hands can cause injury. Always wear gloves when using a **SST** (piano wire).

5. Wind each end of the **SST** (piano wire) around a bar.

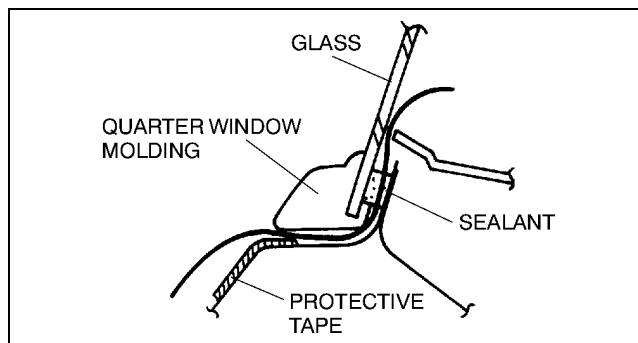

A3U0912W003

6. Working with another person, saw through the sealant around the edge of the glass, being careful to not damage the vehicle body.

**Note**

- Use a long sawing action to spread the work over the whole length of the **SST** (piano wire) to prevent it from breaking.

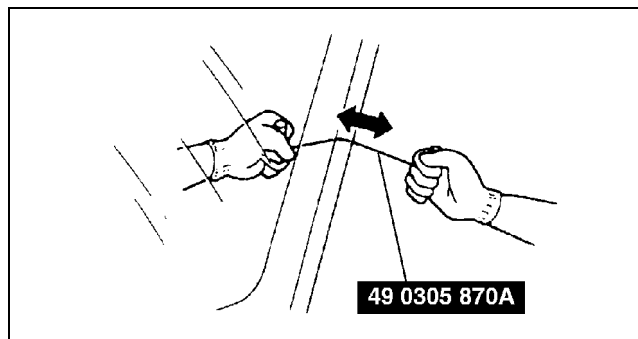

X3U912WAB

09-12

7. Pull the quarter window glass, then disengage the fastener, pin and clip.
8. Remove the fastener and pin from the body.

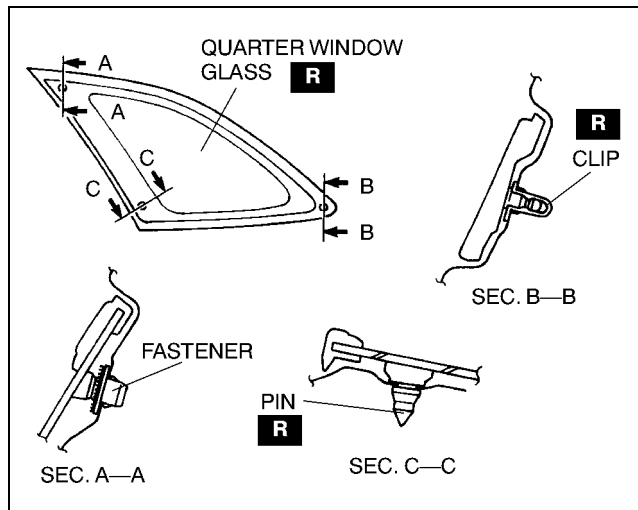

A3U0912W004

# GLASS/WINDOWS/MIRRORS

## QUARTER WINDOW GLASS INSTALLATION

A3U091262580W02

### Caution

- To prevent the sealant from cracking or the glass from being pushed out by air pressure if a door is closed, open all of the windows and leave them open until the sealant has hardened.

- Cut away the old sealant using a razor so that 1—2 mm {0.04—0.07 in} thickness of sealant remains around the circumference of the frame.
  - If all the sealant has come off in any one place, apply some primer after degreasing, and allow it 30 minutes to dry. Then put on new sealant to create 2 mm {0.08 in} layer.

### Warning

- Using a razor with bare hands can cause injury. Always wear gloves when using a razor.

- Clean and degrease the ceramic part of the glass and around the circumference of the bonding area on the body.

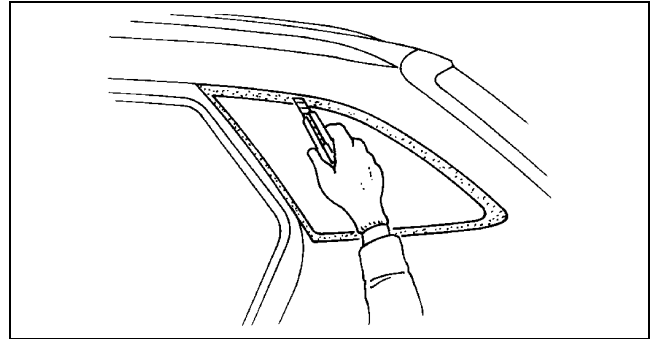

A3U0912W005

- Use a brush to apply primer to the bonding area of the glass and body, within the region shown.

### Caution

- Keep the area free of dirt and grease, and do not touch the surface or primer may not properly bond to the surface of the glass and body, which may cause leaks to occur.

### Note

- Use only glass primer on the glass, and body primer on the body. Allow it to dry for approximately 30 minutes.

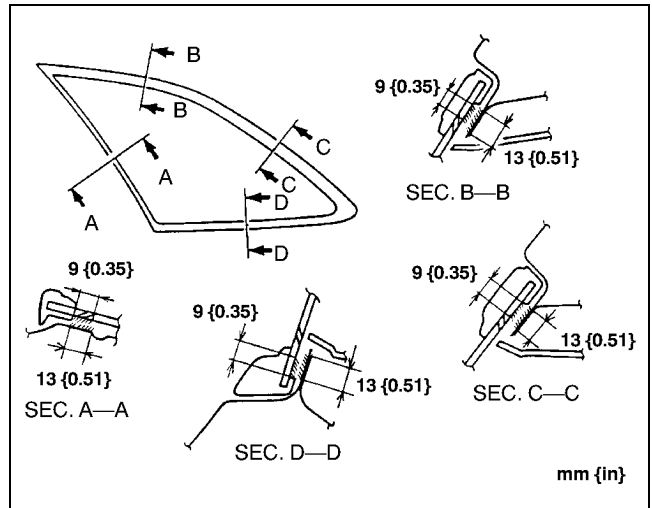

A3U0912W006

- Once the primer is dry, apply sealant around the entire circumference to fill the gap between the dam and the edge of the glass measuring 11.0 mm {0.433 in} high and 5.0 mm {0.20 in} wide.
- Align the fasteners and install the glass onto the body.
- Verify the clearance as shown.

### Clearance

- a: 0 mm {0 in}
- b: 2.0 mm {0.08 in}

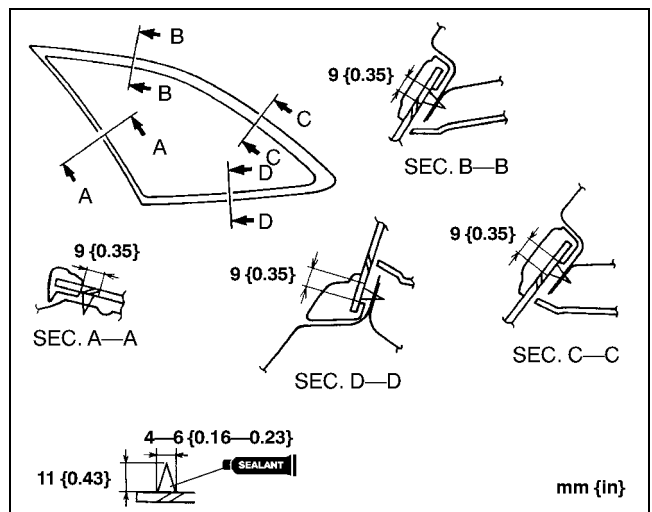

A3U0912W007

# GLASS/WINDOWS/MIRRORS

7. Press firmly inward on the glass to compress the sealant.

## Hardening time of sealant

Temperature	Surface hardening time	Time required until car can be put into service
5 °C {41 °F}	Approx. 1.5 h	Approx. 12 h
20 °C {68 °F}	Approx. 1 h	Approx. 4 h
35 °C {95 °F}	Approx. 10 min.	Approx. 2 h

- Check for water leaks. If a leak is found, wipe the water off well and repeat the installation.
- Install the C-pillar trim. (See 09-17-11 C-PILLAR TRIM REMOVAL/INSTALLATION.)

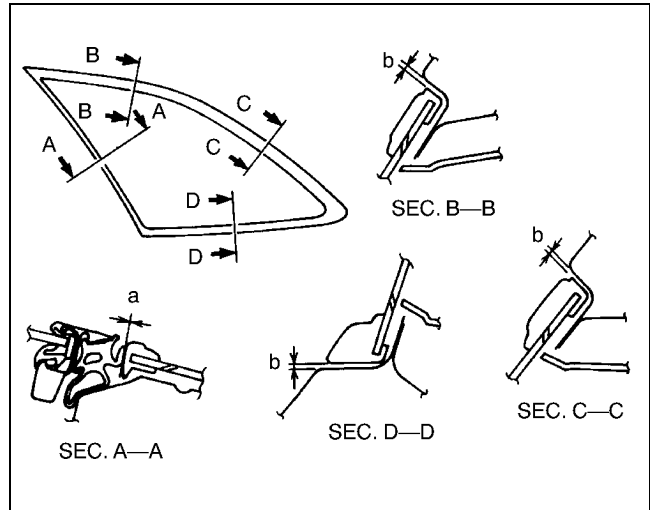

A3U0912W008

## FILAMENT INSPECTION

- Turn the ignition switch to ON position.
- Turn the rear window defroster switch to ON.
- Connect the positive (+) lead of the voltmeter to the positive side of each filament and the negative (-) lead to ground.

A3U091263931W03

### Caution

- Directly touching the rear window defroster filament with the lead of the circuit tester will damage it. Wrap aluminum foil around the end of the lead and test the filament by touching it with the foil.

- Gradually, slide the positive (+) lead from the positive side to the negative side and measure the voltage. Verify that the voltage decreases accordingly.
  - If the voltage is not as specified or it changes rapidly, the filament is faulty. Repair the filament.

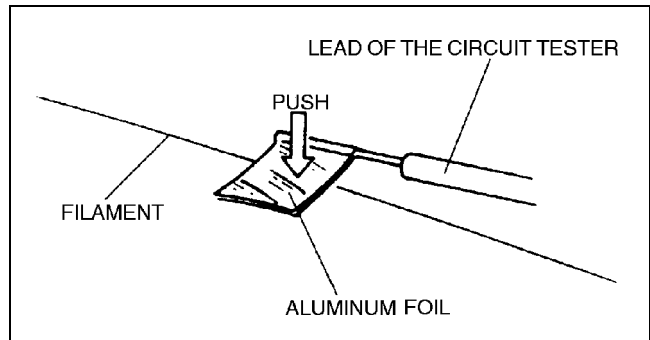

X3U912WA1

09-12

Measurement place	Voltage (Reference value)
(1)→(2)	Approx. 12 V→ Approx. 0 V

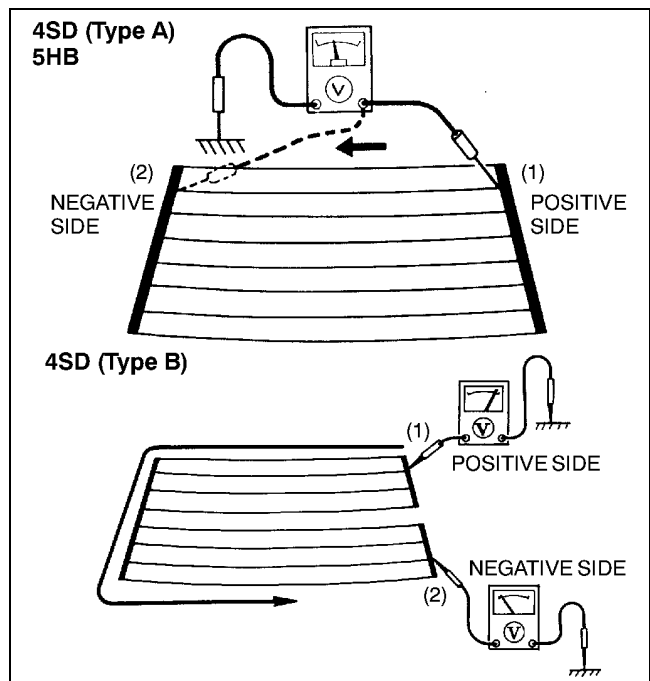

A3U0912W021

# GLASS/WINDOWS/MIRRORS

## FILAMENT REPAIR

A3U091263931W04

1. Use isopropyl alcohol to clean around the damaged section of the filament.
2. Attach tape above and below the damaged section of the filament.
3. Using a small brush or marking pen, repair the filament with silver paint or equivalent.
4. After **approximately 2—3 minutes**, carefully remove the tape without disturbing the repaired area.
5. Use a hot air blower heated to **150 °C {302 °F}** for **30 minutes** or let the paint set for **24 hours** at **25 °C {77 °F}** to allow it to dry completely.

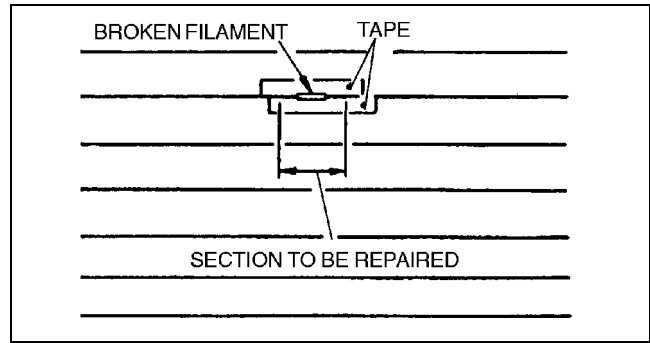

X3U0912WA4

### Caution

- Do not use the rear window defroster until the paint is completely dry. It may cause other malfunctions if it is used before the paint is dry.

## REAR WINDOW DEFROSTER SWITCH INSPECTION

A3U091266460W01

1. Remove the climate control unit. (See 07–40–9 CLIMATE CONTROL UNIT REMOVAL.)
2. Inspect for continuity between the rear window defroster switch terminals using an ohmmeter.

○—○ : Continuity

Switch position	Terminal	
	E	J
OFF		
ON	○—○	○—○

Z3U0912W019

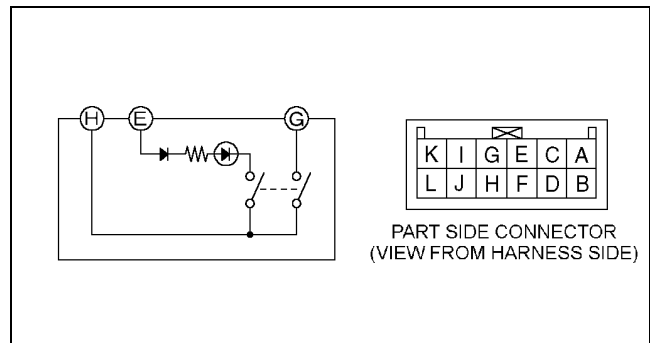

Z3U0912W018

3. Connect battery positive voltage to terminal L and ground to terminal E.
4. Turn the rear window defroster switch to ON.
5. Verify that the LED illuminates.
  - If not as specified, replace the climate control unit.

## POWER OUTSIDE MIRROR INSPECTION

A3U091269110W01

1. Disconnect the power outside mirror connector. (See 09–12–28 POWER OUTSIDE MIRROR REMOVAL/INSTALLATION.)
2. Apply battery positive voltage to the power outside mirror and inspect the operation of the power outside mirror.
  - If not as specified, replace the power outside mirror.

Terminal		Mirror operation
B+	GND	
B	D	Up
D	B	Down
F	D	Left
D	F	Right

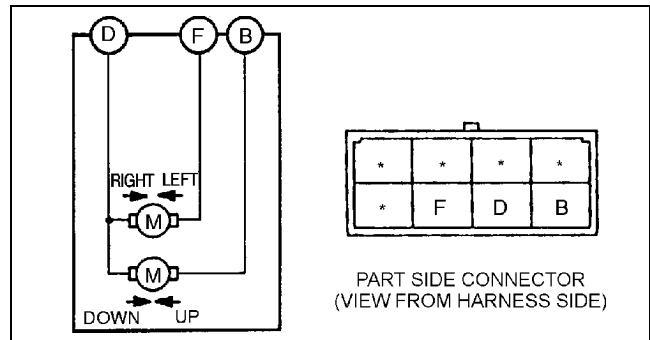

Z3U0912W001

## POWER OUTSIDE MIRROR REMOVAL/INSTALLATION

A3U091269110W02

1. Disconnect the negative battery cable.
2. Remove the front door trim. (See 09–17–9 FRONT DOOR TRIM REMOVAL/INSTALLATION.)
3. Partially peel off the door screen.
4. Disconnect the connector.

## GLASS/WINDOWS/MIRRORS

5. Remove the nuts, and then remove the power outside mirror.
6. Install in the reverse order of removal.

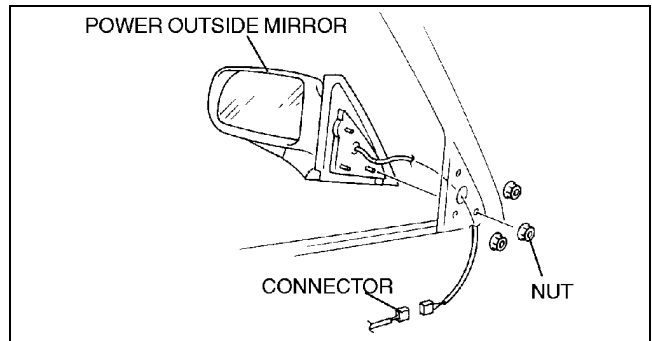

X3U912WD8

### MANUAL OUTSIDE MIRROR REMOVAL/INSTALLATION

1. Remove the inner garnish.
2. Remove the nuts, and then remove the manual outside mirror.
3. Install in the reverse order of removal.

A3U091269100W01

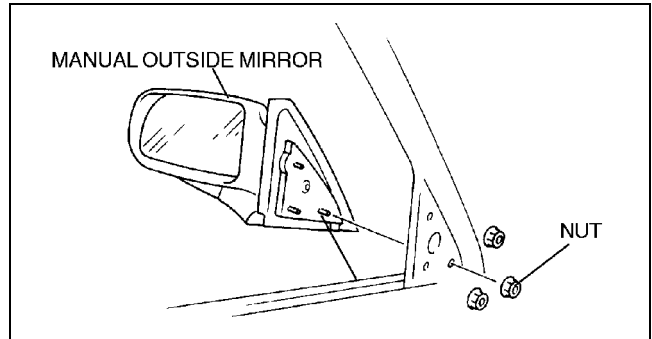

X3U912WD7

### OUTSIDE MIRROR GLASS REMOVAL

1. Warm the frame and the mirror glass to **approximately 70 °C {158 °F}** for 3 minutes using a hot air blower.
2. Put on gloves and protective eye wear.
3. Insert a tape-wrapped scraper between the mirror glass and the frame, and pry the glass loose.

A3U091269111W01

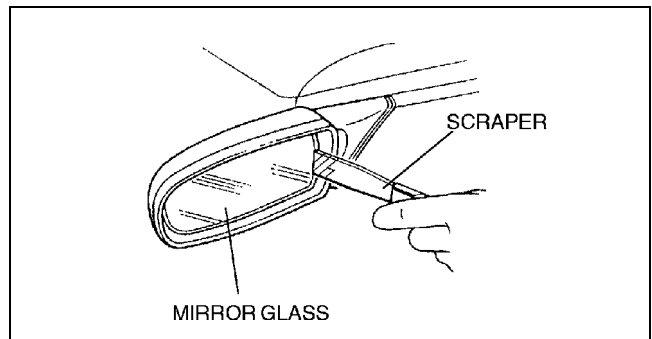

X3U912WD9

### OUTSIDE MIRROR GLASS INSTALLATION

1. Clean and degrease the adhesion surface of the mirror glass.
2. Stick double-sided adhesive tape onto the back of the mirror glass.
3. Warm up the frame using a hot air blower.
4. Remove the paper backing from the double-sided adhesive tape on the back of the mirror glass.
5. Insert the mirror glass into the frame, then press lightly on the glass to secure it.

A3U091269111W02

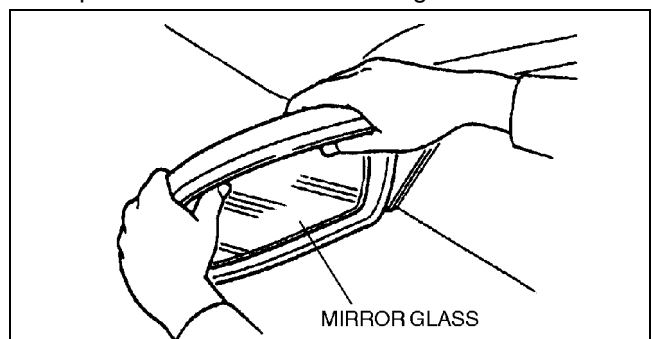

X3U912WE0

# GLASS/WINDOWS/MIRRORS

## POWER OUTSIDE MIRROR SWITCH REMOVAL/INSTALLATION

A3U091266600W01

1. Disconnect the negative battery cable.
2. Remove the driver-side front door trim. (See 09-17-9 FRONT DOOR TRIM REMOVAL/INSTALLATION.)
3. Push the clip from the reverse side of the trim to remove the switch panel.
4. Disconnect the connector.
5. Remove the screws, and then remove the power outside mirror switch.
6. Install in the reverse order of removal.

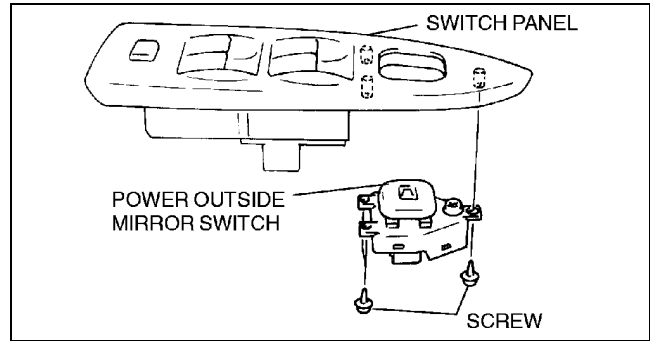

X3U912WE2

## POWER OUTSIDE MIRROR SWITCH INSPECTION

A3U091266600W02

1. Remove the power outside mirror switch. (See 09-12-30 POWER OUTSIDE MIRROR SWITCH REMOVAL/INSTALLATION.)
2. Inspect for continuity between the power outside mirror switch terminals using an ohmmeter.
  - If not as specified, replace the power outside mirror switch.

○—○ : Continuity

Switch position	Operation	Terminal						
		F	D	H	L	J	K	I
LH	Up	○						○
	Down	○	○	○				○
	Left	○	○		○			
	Right	○	○	○				
RH	Up	○				○		○
	Down	○	○					○
	Left	○	○			○		
	Right	○	○			○		

X3U912WE3

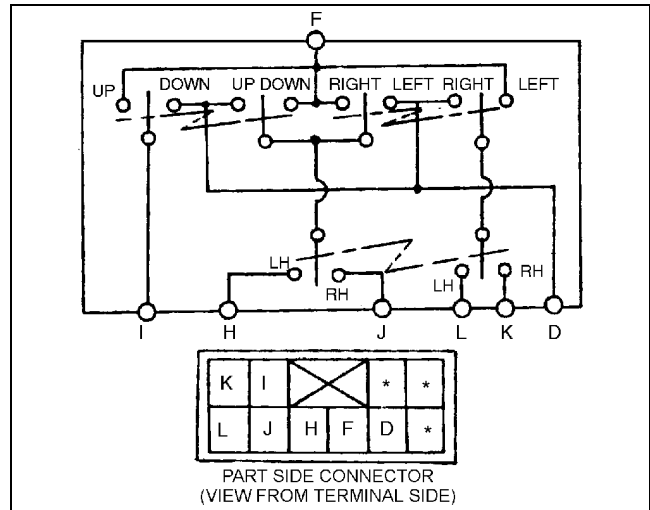

Z3U0912W014

## REARVIEW MIRROR REMOVAL

A3U091269220W01

1. Insert a flathead screwdriver between the mirror and the base.
2. Push the base pin down to remove the rearview mirror.

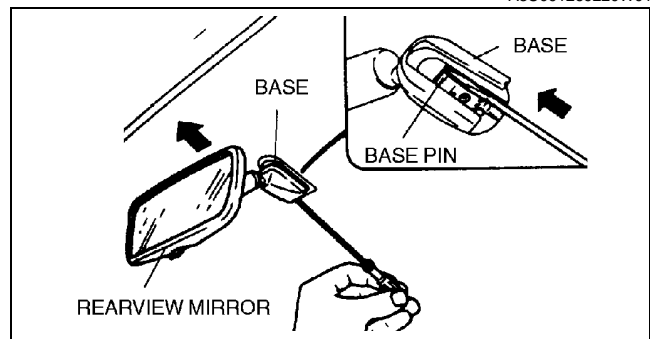

X3U912WE5

# GLASS/WINDOWS/MIRRORS

## REARVIEW MIRROR INSTALLATION

1. Install the rearview mirror onto the base.

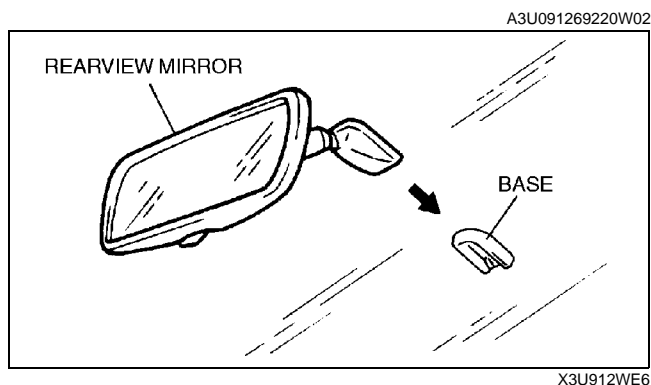

## BASE REMOVAL

1. Remove the rearview mirror.
2. Wind each end of a wire around a bar.
3. Saw through the sealant to remove the base.

### Note

- Use a long sawing action to spread the work over the whole length of the **SST** (piano wire) to prevent it from breaking.

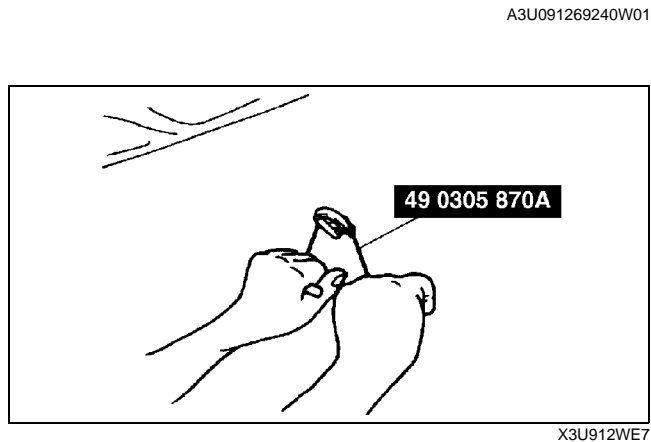

## BASE INSTALLATION

1. Cut away all of the original sealant using a razor.
2. Clean and degrease the ceramic coating on the glass and the base.
3. Apply primer to the bonding area of the glass and the base.

### Caution

- **Keep the area free of dirt and grease, and do not touch the surface, otherwise the primer may not properly bond to the surface of the glass.**

4. Apply a height of **3.0 mm {0.12in}** sealant to the base.

### Note

- Use only glass primer on the glass, and body primer on the base. Allow the primer to dry for **approximately 30 minutes**.

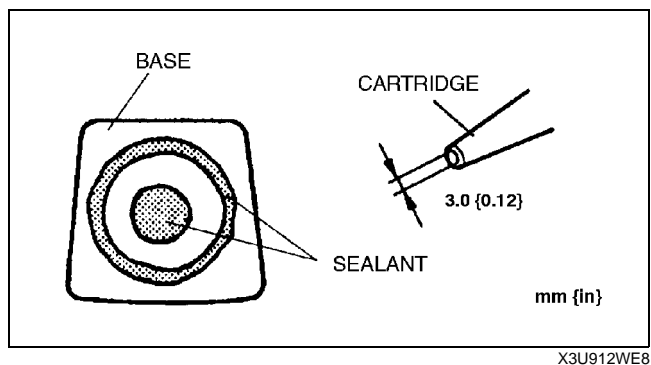



## GLASS/WINDOWS/MIRRORS

- Center the base in the ceramic coating and press it onto the glass.
- Use isopropyl alcohol to remove any excess repair sealant.

### Hardening time of sealant

Temperature	Surface hardening time	Time required until car can be put into service
5 °C {41 °F}	Approx. 1.5 h	Approx. 12 h
20 °C {68 °F}	Approx. 1 h	Approx. 4 h
35 °C {95 °F}	Approx. 10 min.	Approx. 2 h

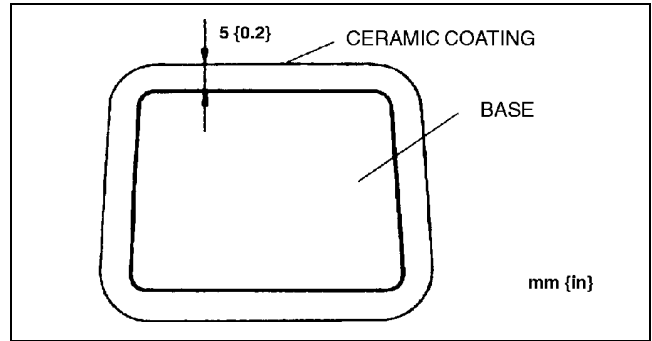

X3U912WE9

- Install the rearview mirror.

## 09-13 SEATS

### FRONT SEAT

<b>REMOVAL/INSTALLATION</b> . . . . .	<b>09-13-1</b>
Side Air Bag Module Connector	
Removal Note . . . . .	<b>09-13-1</b>
Side Air Bag Module Connector	
Installation Note . . . . .	<b>09-13-2</b>
Buckle Switch Connector	
Installation Note . . . . .	<b>09-13-2</b>

### FRONT SEAT

<b>DISASSEMBLY/ASSEMBLY</b> . . . . .	<b>09-13-2</b>
Driver's Seat . . . . .	<b>09-13-2</b>
Passenger's Seat . . . . .	<b>09-13-4</b>
<b>REAR SEAT REMOVAL/INSTALLATION</b>	<b>09-13-5</b>
4SD . . . . .	<b>09-13-5</b>
5HB . . . . .	<b>09-13-5</b>
<b>REAR SEAT DISASSEMBLY/ASSEMBLY</b>	<b>09-13-7</b>
4SD . . . . .	<b>09-13-7</b>
5HB . . . . .	<b>09-13-8</b>

### FRONT SEAT REMOVAL/INSTALLATION

A3U091357100W01

#### Warning

- Handling the front seat (side air bag) improperly can accidentally deploy the side air bag, which may seriously injure you. Read AIR BAG SYSTEM SERVICE WARNINGS before handling the front seat. (See 08-10-3 AIR BAG SYSTEM SERVICE WARNINGS.)

1. Turn the ignition switch to the LOCK position.
2. Disconnect the negative battery cable and wait for **more than 1 minute**.
3. Remove in the order indicated in the table.

1	Side air bag module connector (Vehicles with side air bag) (See 09-13-1 Side Air Bag Module Connector Removal Note) (See 09-13-2 Side Air Bag Module Connector Installation Note)
2	Buckle switch connector (See 09-13-2 Buckle Switch Connector Installation Note)
3	Cover
4	Front seat

4. Install in the reverse order of removal.

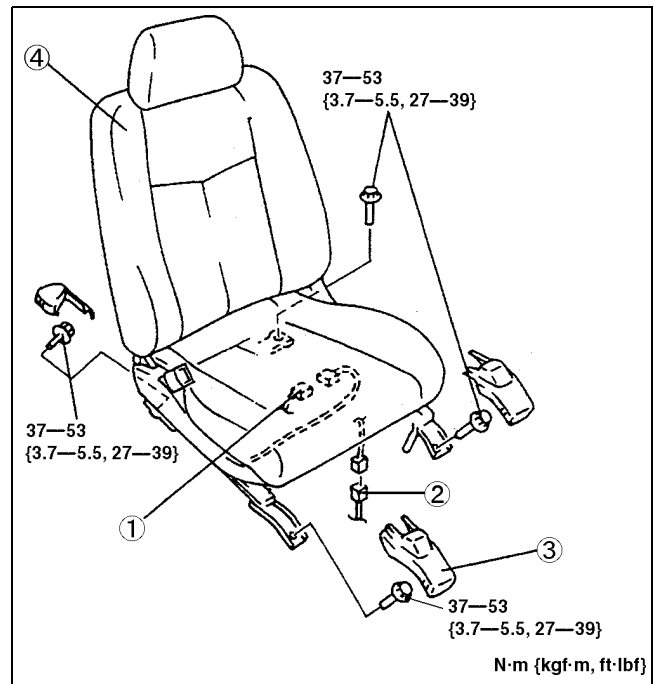

Z3U0913W001

#### Side Air Bag Module Connector Removal Note

1. Remove the connector from the seat cushion frame, then disconnect the side air bag module connector.

## SEATS

### Side Air Bag Module Connector Installation Note

1. Be sure to pass the side air bag module connector (vehicle-side harness connector) under the slide connecting wire before connecting it to the harness connector of the side air bag module.
2. After connecting the connectors, secure them to the seat cushion frame.

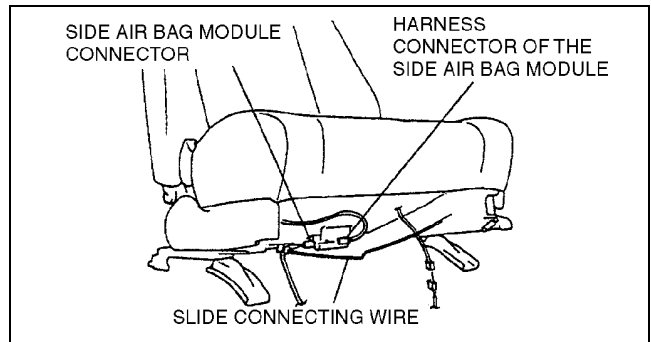

Y3U913WA1

### Buckle Switch Connector Installation Note

1. Be sure to pass the harness connector of the buckle switch under the slide connecting wire before connecting it to the buckle switch connector (vehicle-side harness connector).

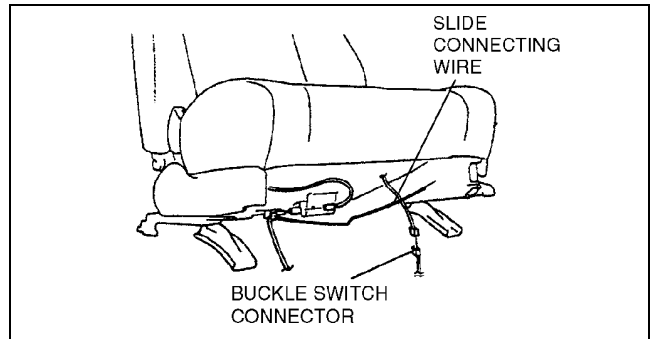

Y3U913WA2

## FRONT SEAT DISASSEMBLY/ASSEMBLY

### Driver's Seat

A3U091357100W02

#### Warning

- Handling the front seat (side air bag) improperly can accidentally deploy the side air bag, which may seriously injure you. Read AIR BAG SYSTEM SERVICE WARNINGS before handling the front seat. (See 08-10-3 AIR BAG SYSTEM SERVICE WARNINGS.)

1. Remove the driver-side side air bag module. (See 08-10-5 DRIVER-SIDE AIR BAG MODULE REMOVAL/INSTALLATION.)
2. Disassemble in the order indicated in the table.
3. Assemble in the reverse order of disassembly.

# SEATS

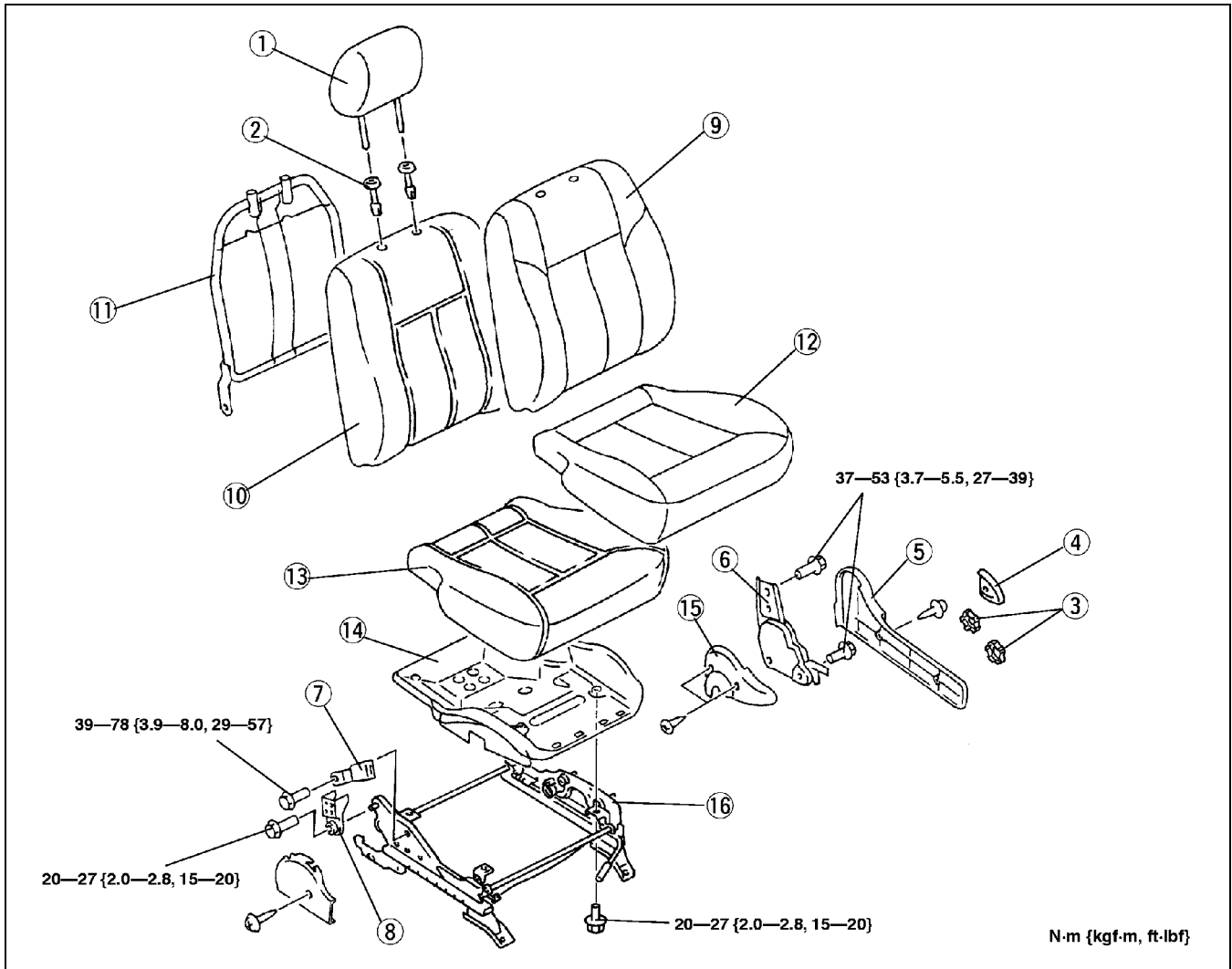

09-13

X3U913WA5

1	Headrest
2	Pole guide
3	Tilt dial
4	Recliner lever
5	Side cover (See 09-13-3 Side cover removal note)
6	Recliner knuckle
7	Front buckle
8	Hinge cover

9	Seat back trim
10	Seat back pad
11	Seat back frame
12	Seat cushion trim
13	Seat cushion pad
14	Seat cushion frame
15	Reverse cover
16	Slide adjuster

### Side cover removal note

1. Remove the screws.
2. Lift the side cover up in the direction of the arrow, then unhook it from the recliner knuckle.

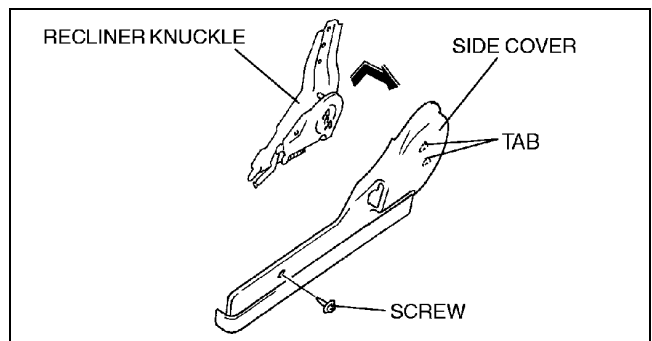

Y3U913WA3

# SEATS

## Passenger's Seat

### Warning

- Handling the front seat (side air bag) improperly can accidentally deploy the side air bag, which may seriously injure you. Read AIR BAG SYSTEM SERVICE WARNINGS before handling the front seat. (See 08-10-3 AIR BAG SYSTEM SERVICE WARNINGS.)

1. Remove the passenger-side side air bag module. (See 08-10-6 PASSENGER-SIDE AIR BAG MODULE REMOVAL/INSTALLATION.)
2. Disassemble in the order indicated in the table.
3. Assemble in the reverse order of disassembly.

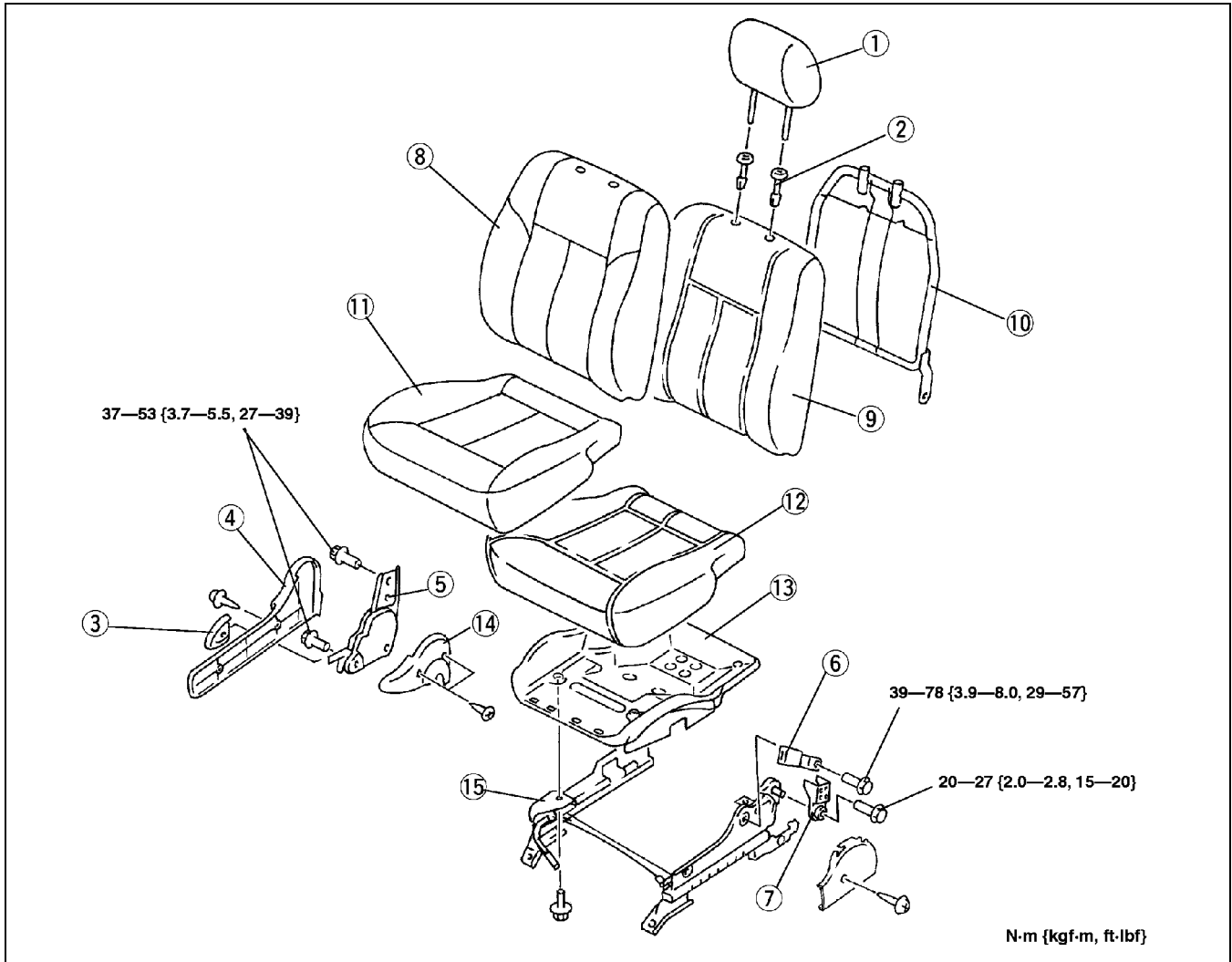

X3U913WA6

1	Headrest
2	Pole guide
3	Recliner lever
4	Side cover (See 09-13-3 Side cover removal note)
5	Recliner knuckle
6	Front buckle
7	Hinge cover

8	Seat back trim
9	Seat back pad
10	Seat back frame
11	Seat cushion trim
12	Seat cushion pad
13	Seat cushion frame
14	Reverse cover
15	Slide adjuster

# SEATS

## REAR SEAT REMOVAL/INSTALLATION

A3U091357200W01

### 4SD

1. Remove in the order indicated in the table.
2. Install in the reverse order of removal.

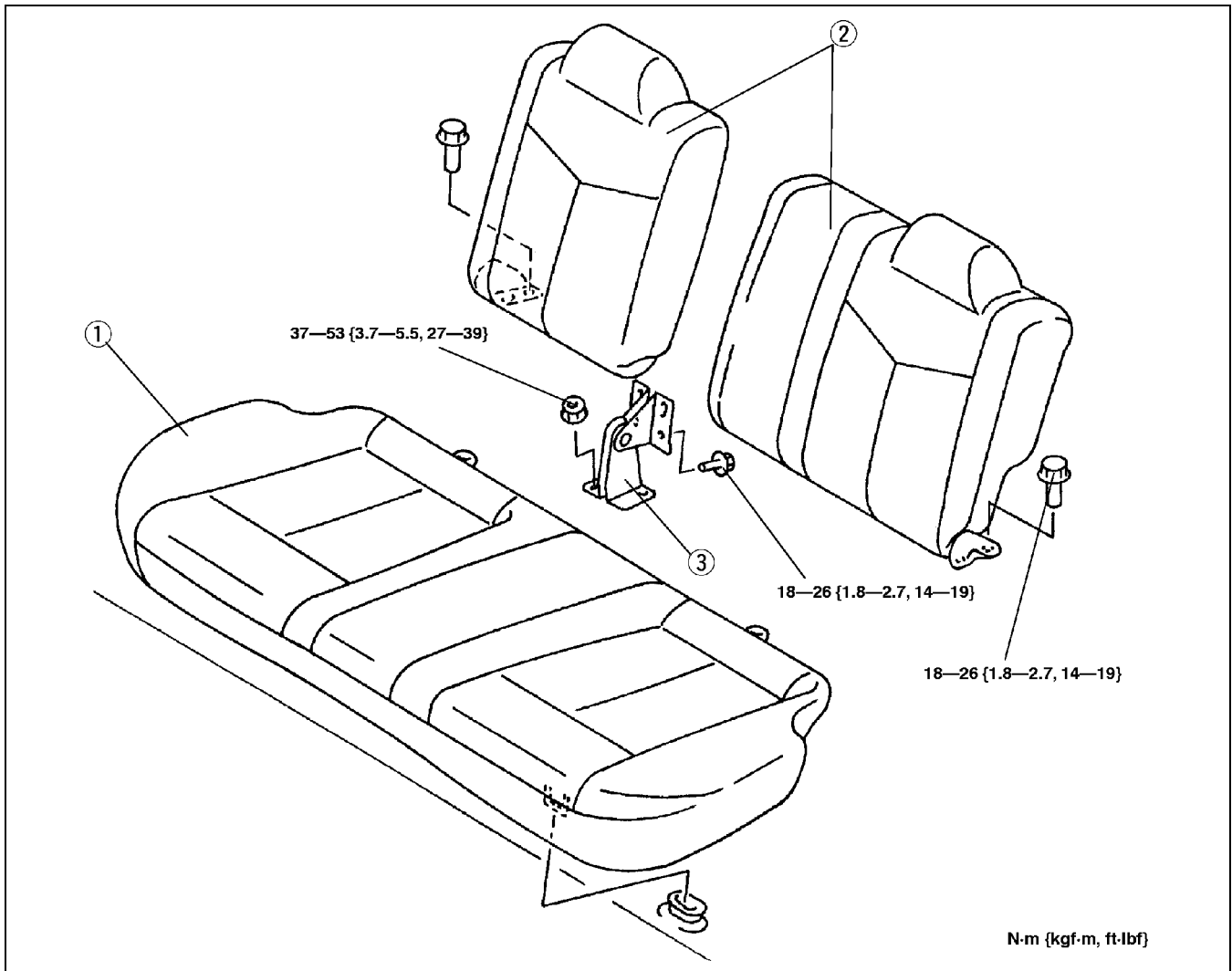

X3U913WA9

1	Rear seat cushion
2	Rear seat back

3	Center hinge
---	--------------

### 5HB

#### Rear seat cushion

1. Lift up the rear seat cushion.
2. Pull the stopper to release the lever, and remove the rear seat cushion.
3. Install in the reverse order of removal.

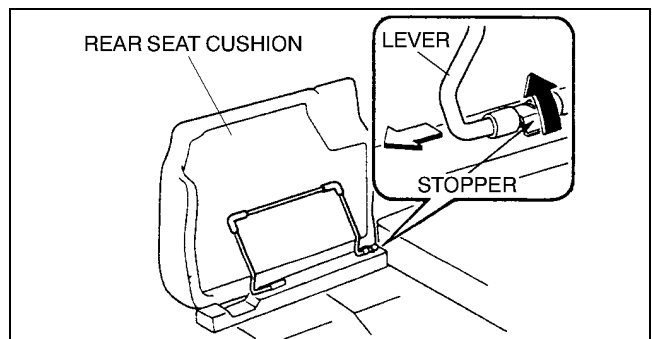

A3U0913W001

# SEATS

## Rear seat back

1. Lift up the rear seat cushion.
2. Remove the service hole cover.
3. Remove in the order indicated in the table.

1	Rear seat back
2	Center hinge

4. Install in the reverse order of removal.

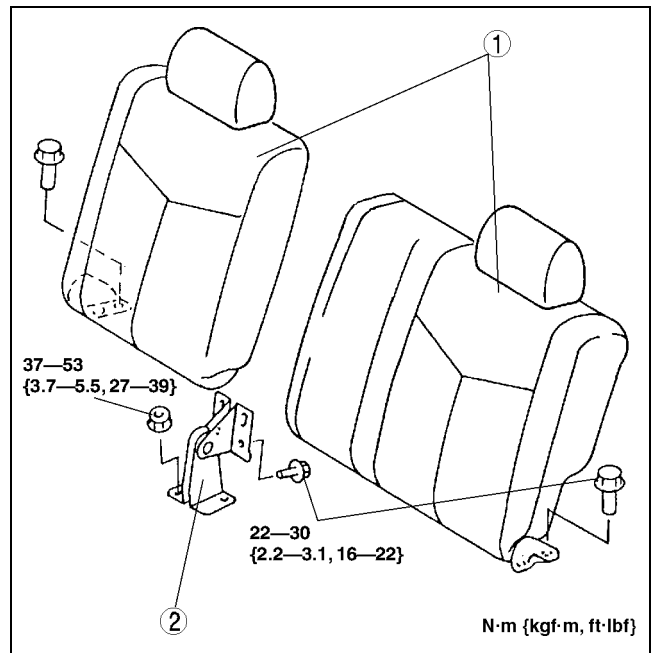

A3U0913W002

# SEATS

## REAR SEAT DISASSEMBLY/ASSEMBLY

A3U091357200W02

### 4SD

1. Disassemble in the order indicated in the table.
2. Assemble in the reverse order of disassembly.

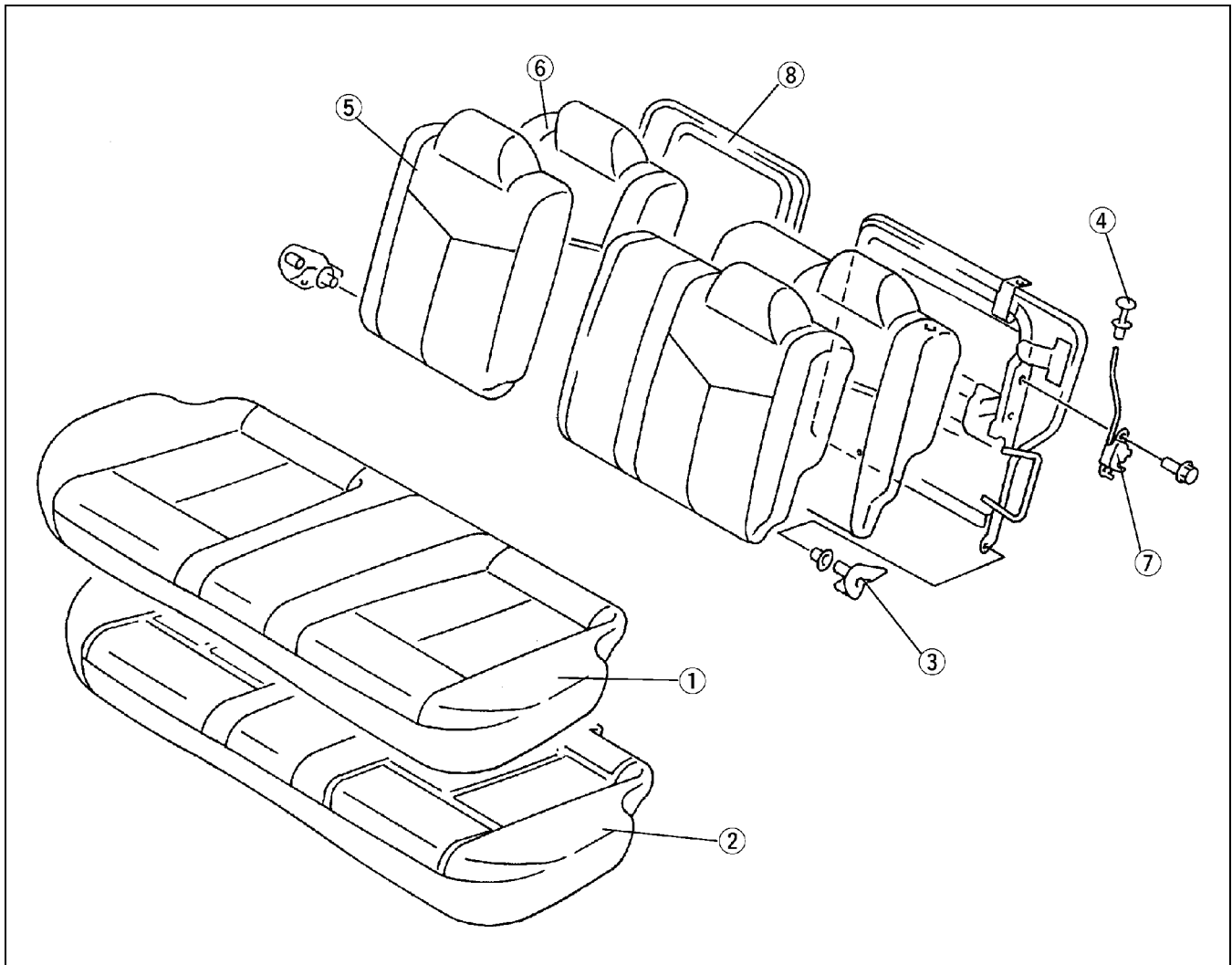

X3U913WAB

1	Seat cushion trim
2	Seat cushion pad
3	Side hinge
4	Recliner knob

5	Seat back trim
6	Seat back pad
7	Rear back catch
8	Seat back frame



# SEATS

## 5HB

1. Disassemble in the order indicated in the table.
2. Assemble in the reverse order of disassembly.

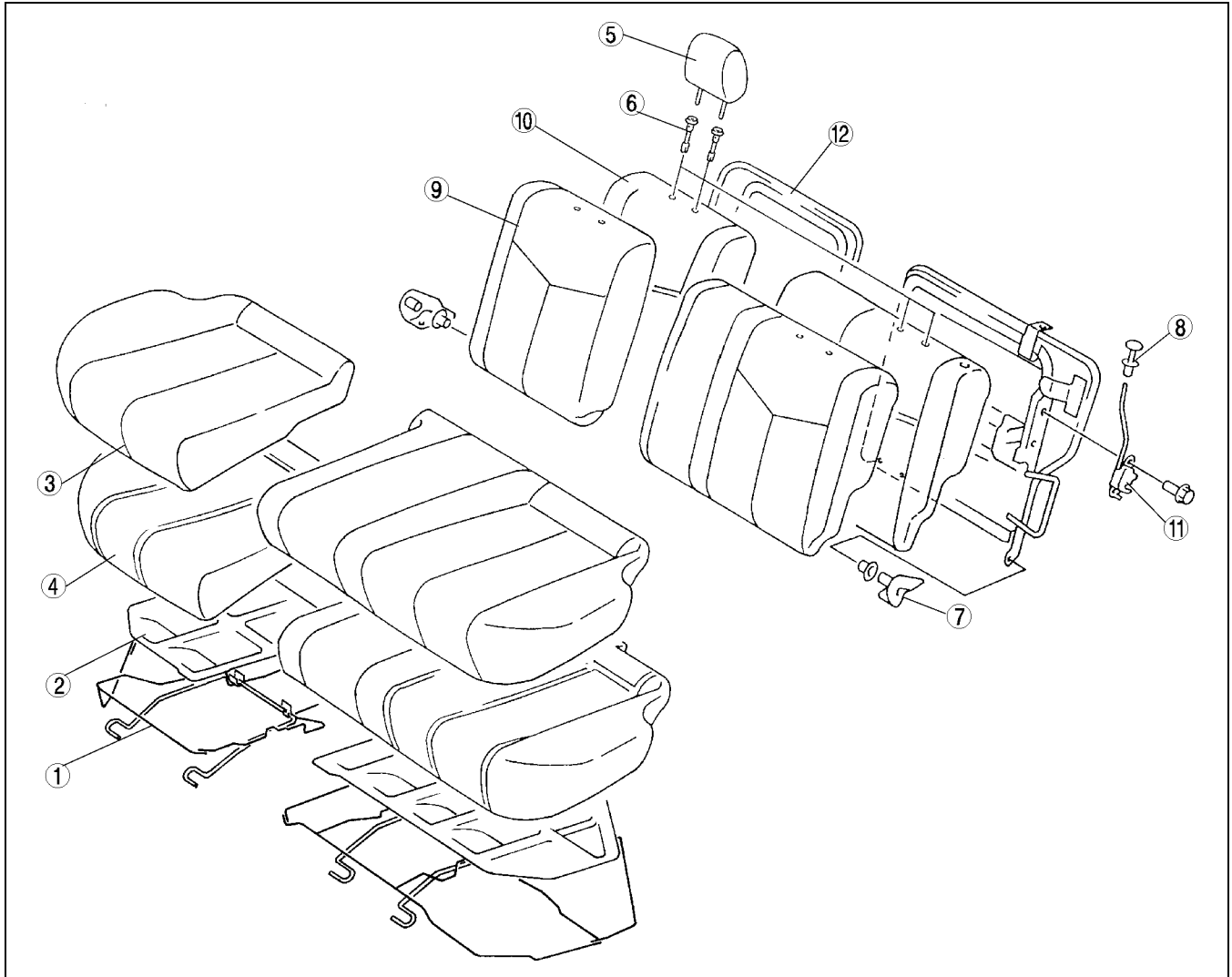

A3U0913W003

1	Seat cushion frame
2	Seat cushion pad cover
3	Seat cushion trim
4	Seat cushion pad
5	Headrest
6	Pole guide

7	Side hinge
8	Recliner knob
9	Seat back trim
10	Seat back pad
11	Rear back catch
12	Seat back frame

## **09-14 SECURITY AND LOCKS**

LOCATION INDEX .....	09-14-2	DOOR LOCK CONTROL MODULE	
FRONT DOOR LOCK AND OPENER		INSPECTION .....	09-14-8
REMOVAL/INSTALLATION .....	09-14-3	Terminal Voltage List (Reference) ....	09-14-8
FRONT DOOR LOCK ACTUATOR		DOOR LOCK CONTROL MODULE	
INSPECTION .....	09-14-3	REMOVAL/INSTALLATION .....	09-14-10
FRONT DOOR LOCK ACTUATOR		KEYLESS ENTRY SYSTEM	
REMOVAL/INSTALLATION .....	09-14-3	WIRING DIAGRAM .....	09-14-10
DOOR LOCK-LINK SWITCH		KEYLESS CONTROL MODULE	
INSPECTION .....	09-14-4	INSPECTION .....	09-14-11
DOOR LOCK-LINK SWITCH		Terminal Voltage List (Reference) ....	09-14-11
REMOVAL/INSTALLATION .....	09-14-4	KEYLESS CONTROL MODULE	
REAR DOOR LOCK AND OPENER		REMOVAL/INSTALLATION .....	09-14-12
REMOVAL/INSTALLATION .....	09-14-4	4SD .....	09-14-12
REAR DOOR LOCK ACTUATOR		5HB .....	09-14-13
INSPECTION .....	09-14-5	KEYLESS CONTROL MODULE	
REAR DOOR LOCK ACTUATOR		ID CODE CHANGE .....	09-14-14
REMOVAL/INSTALLATION .....	09-14-5	TRANSMITTER BATTERY INSPECTION	09-14-15
LIFTGATE LOCK ACTUATOR		TRANSMITTER BATTERY	
INSPECTION .....	09-14-5	REPLACEMENT .....	09-14-15
LIFTGATE LOCK ACTUATOR		FUEL-FILLER LID AND OPENER	
REMOVAL/INSTALLATION .....	09-14-5	REMOVAL/INSTALLATION .....	09-14-16
DOOR KEY CYLINDER SWITCH		HOOD LOCK AND OPENER	
INSPECTION .....	09-14-6	REMOVAL/INSTALLATION .....	09-14-17
DOOR KEY CYLINDER SWITCH		TRUNK LID LOCK	
REMOVAL/INSTALLATION .....	09-14-6	REMOVAL/INSTALLATION .....	09-14-17
DOOR LOCK SWITCH INSPECTION ...	09-14-6	Internal Trunk Lid Release Handle	
DOOR LOCK SWITCH		Installation Note .....	09-14-17
REMOVAL/INSTALLATION .....	09-14-7	TRUNK LID OPENER	
DOOR LOCK STRIKER		REMOVAL/INSTALLATION .....	09-14-18
REMOVAL/INSTALLATION .....	09-14-7	TRUNK LID OPENER CABLE	
LIFTGATE LOCK STRIKER		ADJUSTMENT .....	09-14-18
REMOVAL/INSTALLATION .....	09-14-7	TRUNK LID STRIKER	
POWER DOOR LOCK SYSTEM		REMOVAL/INSTALLATION .....	09-14-18
WIRING DIAGRAM .....	09-14-8		

# SECURITY AND LOCKS

## LOCATION INDEX

A3U09146600W01

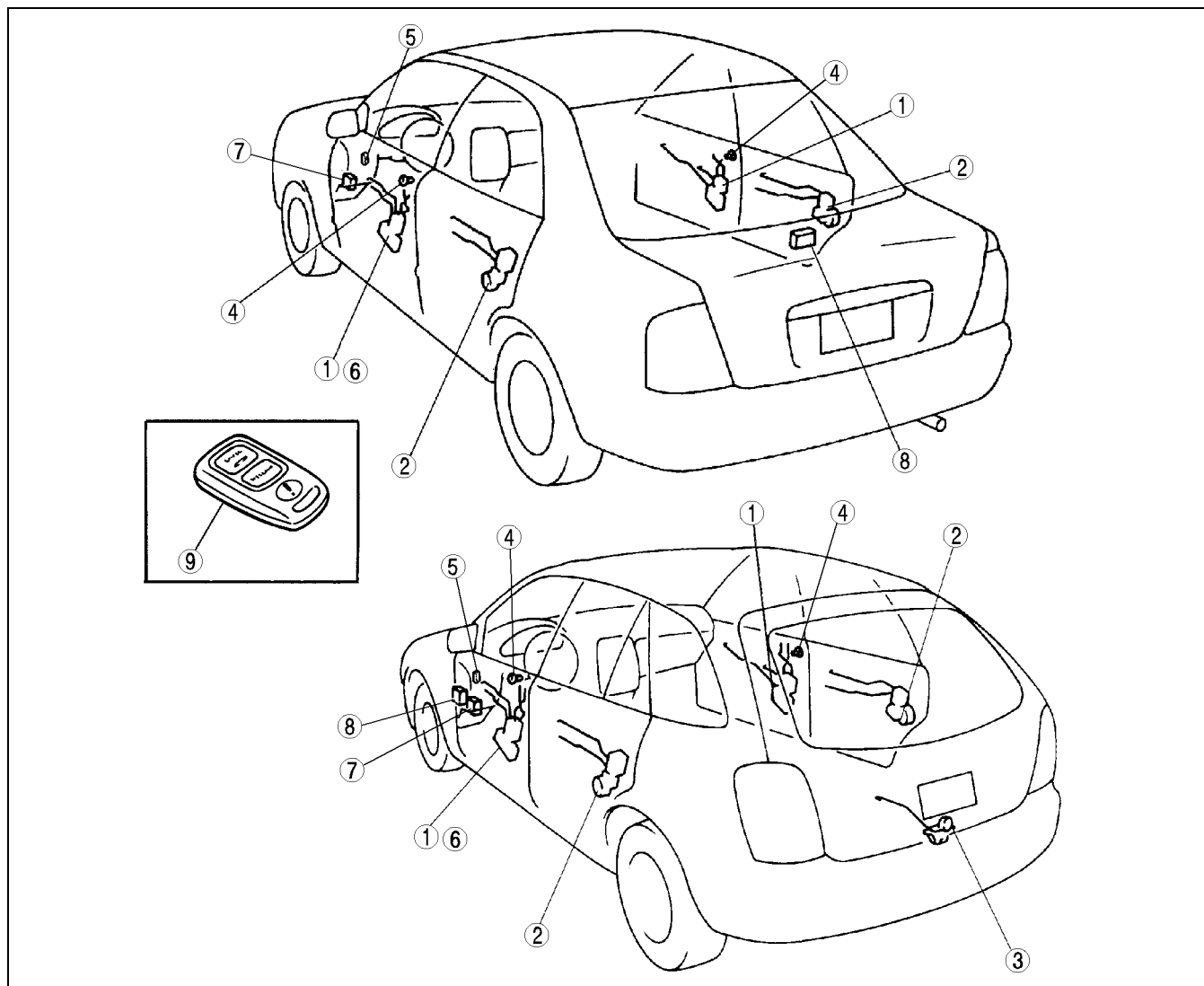

A3U0914W004

1	Front door lock actuator (See 09-14-3 FRONT DOOR LOCK ACTUATOR INSPECTION) (See 09-14-3 FRONT DOOR LOCK ACTUATOR REMOVAL/INSTALLATION)
2	Rear door lock actuator (See 09-14-5 REAR DOOR LOCK ACTUATOR INSPECTION) (See 09-14-5 REAR DOOR LOCK ACTUATOR REMOVAL/INSTALLATION)
3	Liftgate lock actuator (See 09-14-5 LIFTGATE LOCK ACTUATOR INSPECTION) (See 09-14-5 LIFTGATE LOCK ACTUATOR REMOVAL/INSTALLATION)
4	Door key cylinder switch (See 09-14-6 DOOR KEY CYLINDER SWITCH INSPECTION) (See 09-14-6 DOOR KEY CYLINDER SWITCH REMOVAL/INSTALLATION)
5	Door lock switch (See 09-14-6 DOOR LOCK SWITCH INSPECTION) (See 09-14-7 DOOR LOCK SWITCH REMOVAL/INSTALLATION)

6	Door lock-link switch (See 09-14-4 DOOR LOCK-LINK SWITCH INSPECTION) (See 09-14-4 DOOR LOCK-LINK SWITCH REMOVAL/INSTALLATION)
7	Door lock control module (See 09-14-8 DOOR LOCK CONTROL MODULE INSPECTION) (See 09-14-10 DOOR LOCK CONTROL MODULE REMOVAL/INSTALLATION)
8	Keyless control module (See 09-14-11 KEYLESS CONTROL MODULE INSPECTION) (See 09-14-12 KEYLESS CONTROL MODULE REMOVAL/INSTALLATION)
9	Transmitter (See 09-14-15 TRANSMITTER BATTERY INSPECTION) (See 09-14-15 TRANSMITTER BATTERY REPLACEMENT)

# SECURITY AND LOCKS

## FRONT DOOR LOCK AND OPENER REMOVAL/INSTALLATION

A3U091458311W01

1. Close the front door glass completely.
2. Disconnect the negative battery cable.
3. Remove the front door trim. (See 09-17-9 FRONT DOOR TRIM REMOVAL/INSTALLATION.)
4. Remove in the order indicated in the table.

1	Inner handle
2	Door screen
3	Front door lock
4	Door lock knob
5	Outer handle
6	Door key cylinder

5. Install in the reverse order of removal.

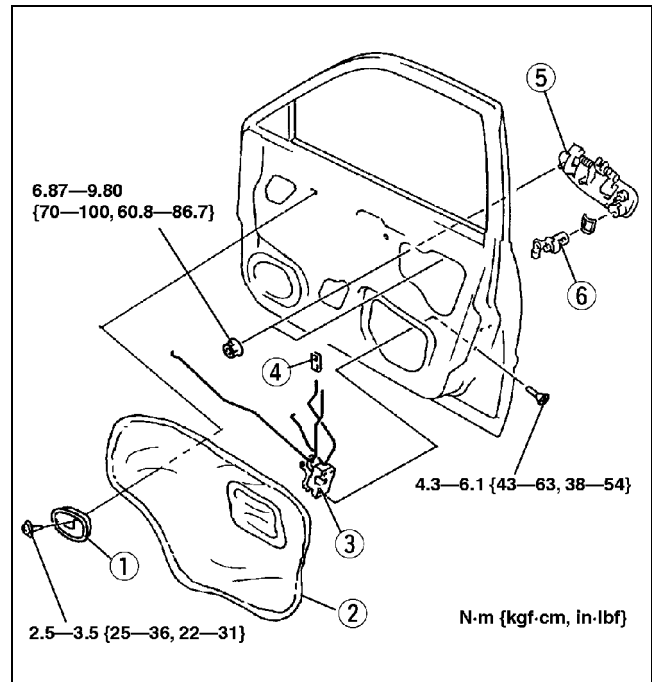

X3U914WA0

## FRONT DOOR LOCK ACTUATOR INSPECTION

A3U091458310W01

1. Remove the front door trim.
2. Turn the door screen over.
3. Disconnect the front door lock actuator connector.
4. Apply battery positive voltage to the front door lock actuator terminals and inspect the operation of the front door lock actuator.
  - If not as specified, replace the front door lock.

Connection		Actuator operation
B+	GND	
E	B	Lock
B	E	Unlock

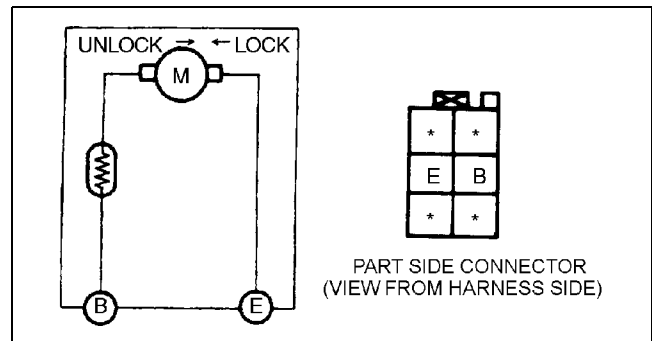

Z3U0914W010

## FRONT DOOR LOCK ACTUATOR REMOVAL/INSTALLATION

A3U091458310W02

1. Disconnect the negative battery cable.
2. Remove the door screen. (See 09-14-3 FRONT DOOR LOCK AND OPENER REMOVAL/INSTALLATION.)
3. Disconnect the front door lock actuator connector.
4. Disconnect the rods from the outer handle and the door key cylinder.
5. Remove the screws, and then remove the front door lock.
6. Remove the screws, and then remove the front door lock actuator from the front door lock.
7. Install in the reverse order of removal.

# SECURITY AND LOCKS

## DOOR LOCK-LINK SWITCH INSPECTION

A3U091458211W01

### Note

- The door lock-link switch is together with the driver-side door lock actuator.

- Remove the driver-side door trim.
- Turn the door screen over.
- Disconnect the door lock-link switch connector.
- Inspect for continuity between the door lock-link switch terminals using an ohmmeter.
  - If not as specified, replace the door lock actuator.

○—○ : Continuity

Lock knob position	Terminal	
	F	D
Lock		
Unlock	○—○	○—○

Z3U0914W012

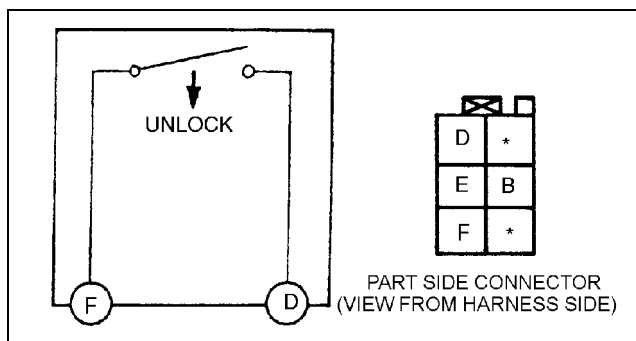

Z3U0914W011

## DOOR LOCK-LINK SWITCH REMOVAL/INSTALLATION

A3U091458211W02

### Note

- The door lock-link switch is together with the driver-side door lock actuator.

- Remove the driver-side door lock actuator. (See 09-14-3 FRONT DOOR LOCK ACTUATOR REMOVAL/INSTALLATION.)

## REAR DOOR LOCK AND OPENER REMOVAL/INSTALLATION

A3U091472311W01

- Close the rear door glass completely.
- Disconnect the negative battery cable.
- Remove the rear door trim. (See 09-17-9 REAR DOOR TRIM REMOVAL/INSTALLATION.)
- Remove in the order indicated in the table.

1	Inner handle
2	Door lock knob
3	Door screen
4	Rear door lock
5	Outer handle

- Install in the reverse order of removal.

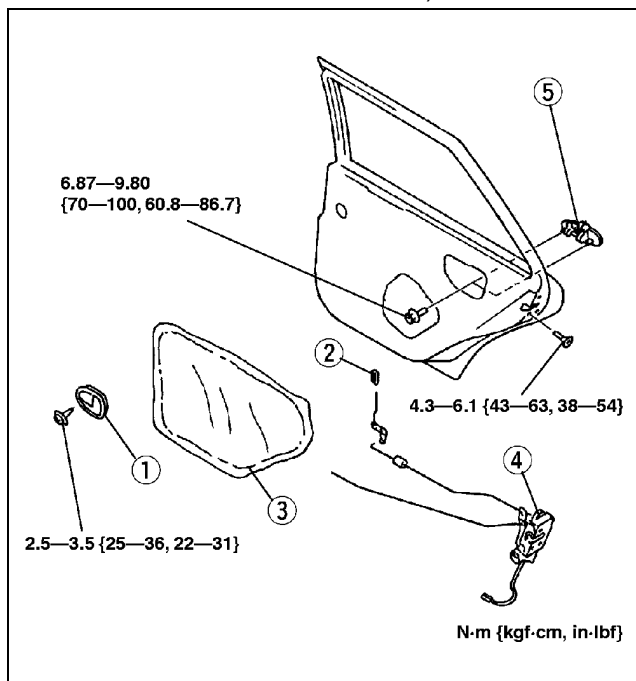

X3U914WA2

# SECURITY AND LOCKS

## REAR DOOR LOCK ACTUATOR INSPECTION

A3U091472310W01

1. Remove the rear door trim.
2. Turn the door screen over.
3. Disconnect the rear door lock actuator connector.
4. Apply battery positive voltage to the rear door lock actuator terminals and inspect the operation of the rear door lock actuator.
  - If not as specified, replace the rear door lock.

Connection		Actuator operation
B+	GND	
E	B	Lock
B	E	Unlock

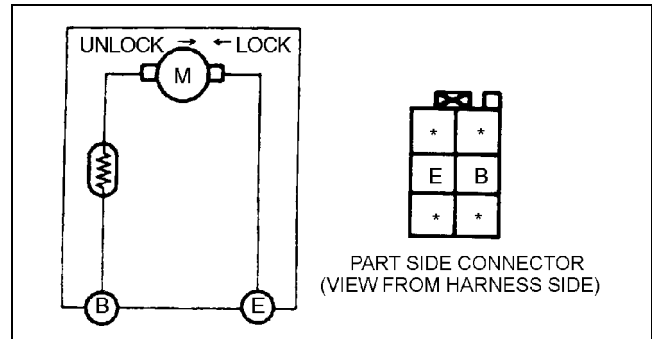

Z3U0914W013

## REAR DOOR LOCK ACTUATOR REMOVAL/INSTALLATION

A3U091472310W02

1. Disconnect the negative battery cable.
2. Remove the door screen. (See 09-14-4 REAR DOOR LOCK AND OPENER REMOVAL/INSTALLATION.)
3. Disconnect the rear door lock actuator connector.
4. Disconnect the rod from the outer handle.
5. Remove the screws, and then remove the rear door lock.
6. Remove the screws, and then remove the rear door lock actuator from the rear door lock.
7. Install in the reverse order of removal.

09-14

## LIFTGATE LOCK ACTUATOR INSPECTION

A3U091462310W01

1. Disconnect the liftgate lock actuator connector.
2. Apply battery positive voltage to the liftgate lock actuator terminals and inspect the operation of the liftgate lock actuator.
  - If not as specified, replace the liftgate lock.

Connection		Actuator operation
B+	GND	
B	A	Lock
A	B	Unlock

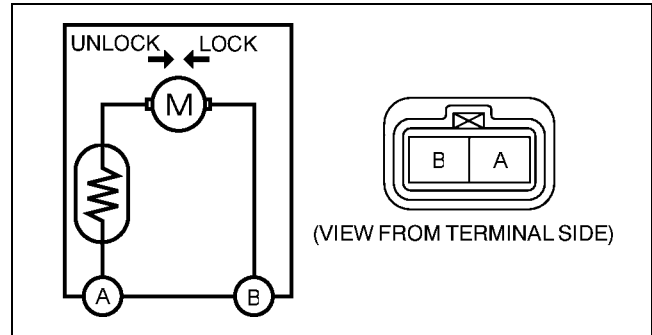

A3U0914W003

## LIFTGATE LOCK ACTUATOR REMOVAL/INSTALLATION

A3U091462310W02

1. Disconnect the negative battery cable.
2. Remove the liftgate lock.
3. Remove the screws, then remove the liftgate lock actuator.
4. Install in the reverse order of removal.

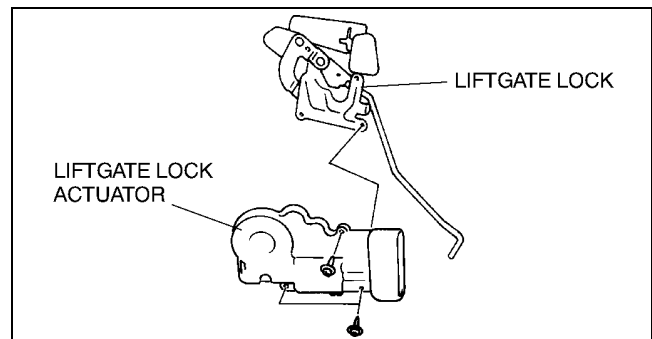

A3U0914W002

# SECURITY AND LOCKS

## DOOR KEY CYLINDER SWITCH INSPECTION

A3U091475911W01

1. Raise the door glass completely.
2. Disconnect the negative battery cable.
3. Remove the passenger-side front door trim.
4. Remove the door screen.
5. Disconnect the door key cylinder switch connector.
6. Inspect for continuity between the door key cylinder switch terminals using an ohmmeter.
  - If not as specified, replace the door key cylinder switch.

○—○ : Continuity ○ $\Omega$ ○ : Resistance

Key cylinder position	Terminal		
	A	C	
Neutral			
Lock	○— $\Omega$ —○		R
Unlock	○—○	○—○	

R: 950—1050  $\Omega$

X3U914WC7

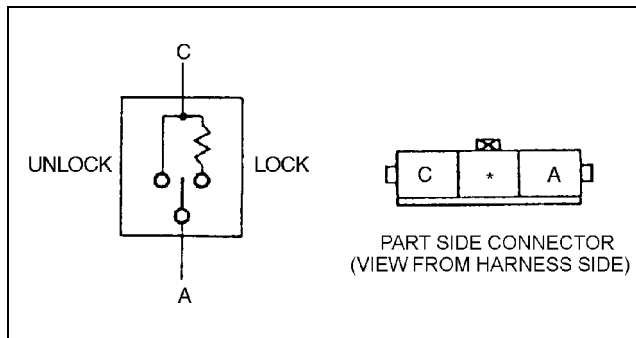

Z3U0914W014

## DOOR KEY CYLINDER SWITCH REMOVAL/INSTALLATION

A3U091475911W02

1. Close the door glass completely.
2. Disconnect the negative battery cable.
3. Remove the passenger-side front door trim.
4. Remove the door screen.
5. Release the outer handle and the door key cylinder installation rods.
6. Disconnect the door key cylinder switch connector.
7. Remove the door key cylinder switch.
8. Install in the reverse order of removal.

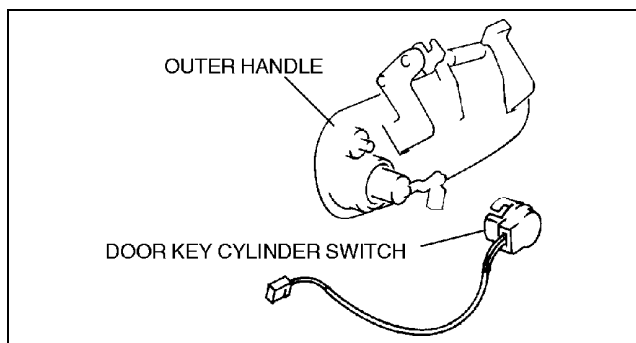

X3U914WA5

## DOOR LOCK SWITCH INSPECTION

A3U091466210W01

1. Remove the door lock switch.
2. Inspect for continuity between the door lock switch terminals using an ohmmeter.
  - If not as specified, replace the door lock switch.

○—○ : Continuity ○ $\Omega$ ○ : Resistance

Switch position	Terminal		
	A	B	
Lock	○— $\Omega$ —○		R
Unlock	○—○	○—○	

R: 950—1050  $\Omega$

X3U914WA7

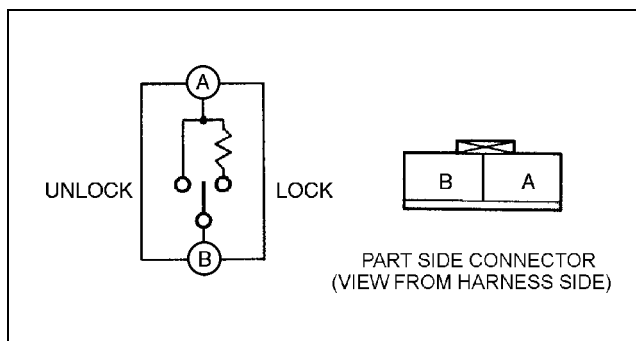

Y3U914WA3

# SECURITY AND LOCKS

## DOOR LOCK SWITCH REMOVAL/INSTALLATION

A3U091466210W02

1. Disconnect the negative battery cable.
2. Insert a tape-wrapped flathead screwdriver between the front door trim and the door lock switch and push the clip to remove the door lock switch.
3. Disconnect the door lock switch connector.
4. Install in the reverse order of removal.

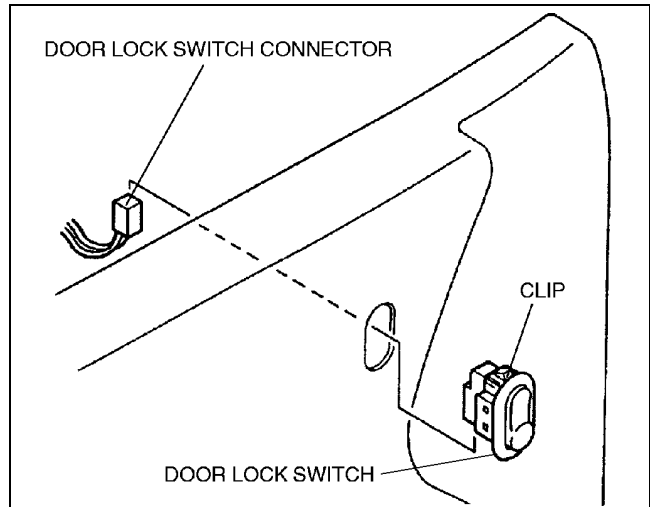

Z3U0914W005

## DOOR LOCK STRIKER REMOVAL/INSTALLATION

A3U091458361W01

### Warning

- Handling the side air bag sensor improperly can accidentally deploy the side air bag module, which may seriously injure you. Read AIR BAG SYSTEM SERVICE WARNINGS before working around the B-pillar areas. (See 08-10-3 AIR BAG SYSTEM SERVICE WARNINGS.)

### Note

- The side air bag sensor is located in the B-pillar.

1. Disconnect the negative battery cable.
2. Remove the screws.
3. Remove the door lock striker.
4. Install in the reverse order of removal.

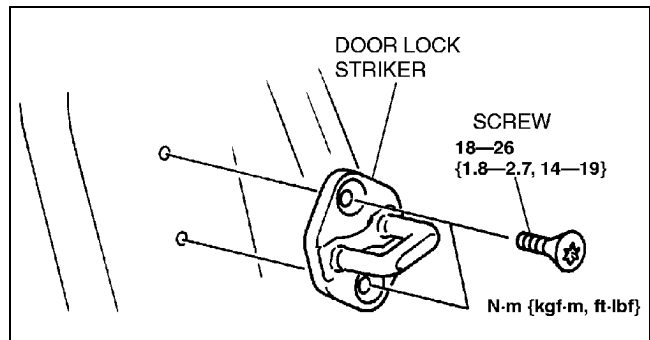

X3U914WA8

## LIFTGATE LOCK STRIKER REMOVAL/INSTALLATION

A3U091462361W01

1. Remove the bolts.
2. Remove the liftgate striker.
3. Install in the reverse order of removal.

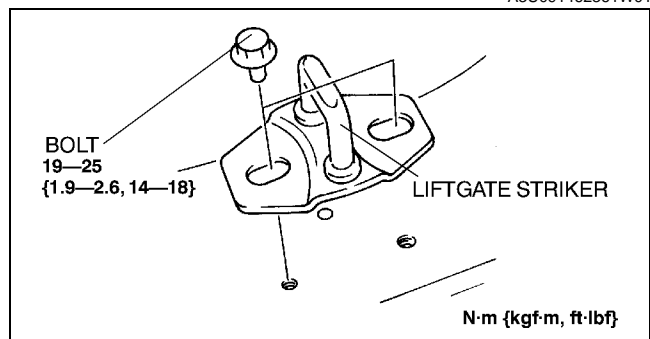

A3U0911W005



# SECURITY AND LOCKS

## POWER DOOR LOCK SYSTEM WIRING DIAGRAM

A3U09146600W02

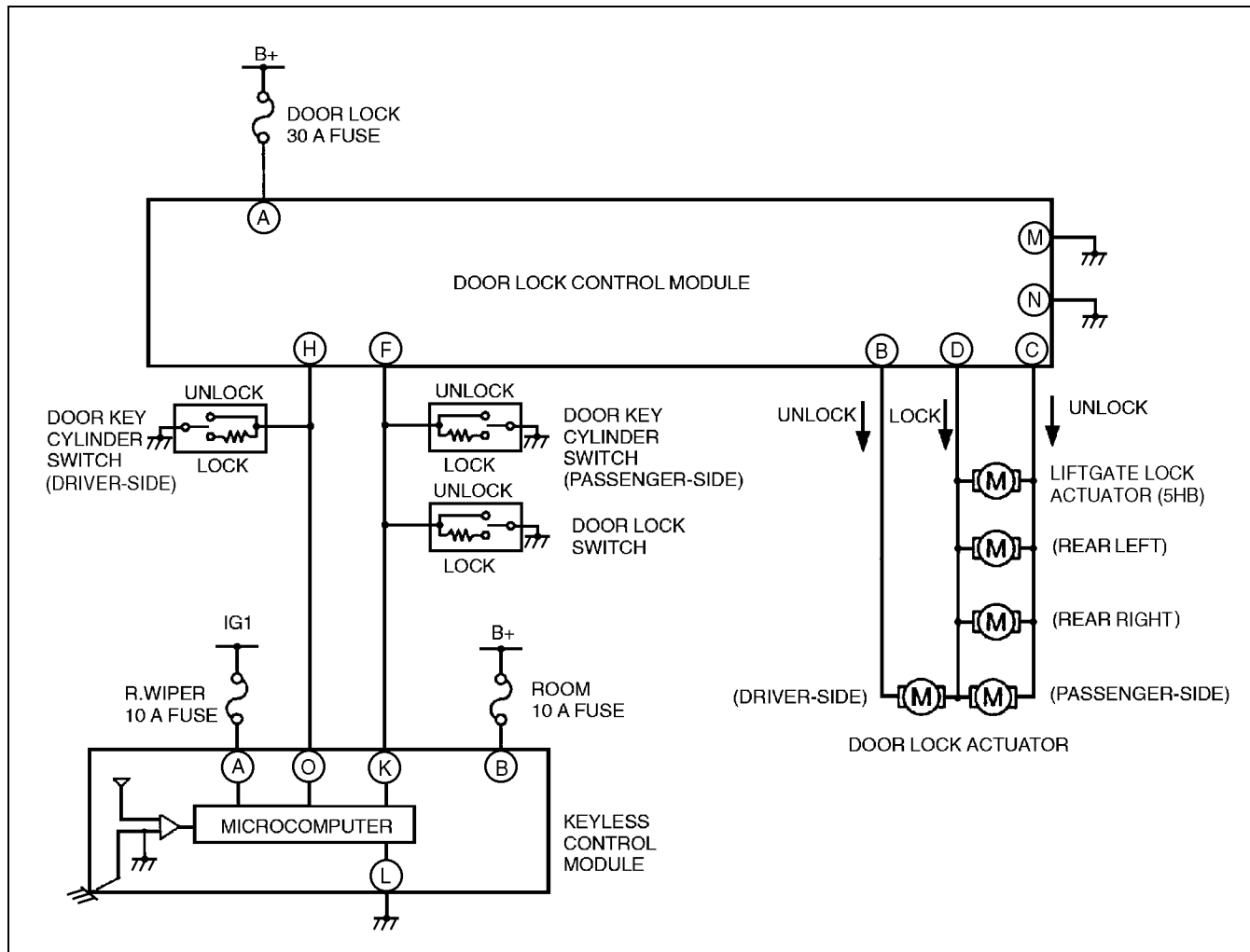

A3U0914W008

### DOOR LOCK CONTROL MODULE INSPECTION

A3U091467830W01

1. Remove the lower panel.
2. Measure the voltage at the door lock control module terminals as indicated below.
3. Disconnect the door lock control module connector before inspecting for continuity at terminals F, H, M and N.
  - If not as specified, inspect the parts listed under "Action" and the related wiring harnesses.
  - If the parts and wiring harnesses are okay but the system still does not work properly, replace the door lock control module.

### Terminal Voltage List (Reference)

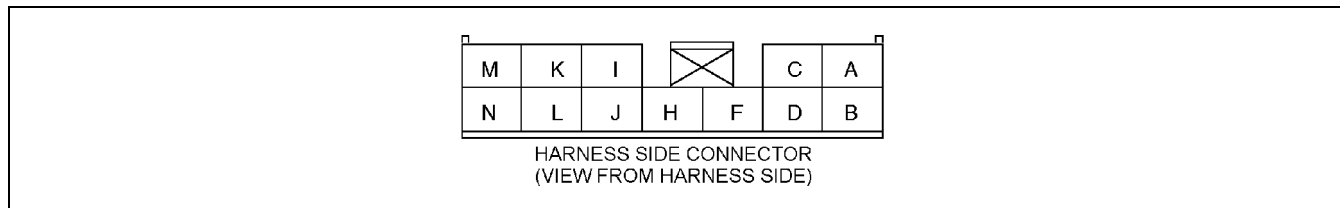

Y3U914WA5

Terminal	Signal	Connected to	Test condition	Voltage (V)/continuity	Action
A	Power supply	DOOR LOCK 30 A fuse	Under any condition	B+	<ul style="list-style-type: none"> <li>• Inspect DOOR LOCK 30 A fuse</li> <li>• Inspect related harness</li> </ul>

## SECURITY AND LOCKS

Terminal	Signal	Connected to	Test condition	Voltage (V)/continuity	Action
B	Unlock output	Driver-side door lock actuator	Driver-side door (door lock actuator) is unlocked	Below 1.0→B+→ Below 1.0	<ul style="list-style-type: none"> <li>Inspect driver-side door lock actuator</li> <li>Inspect related harness</li> </ul>
			Other	0	
C	Unlock output	Except driver-side door lock actuator	Except driver-side door (door lock actuator and liftgate lock actuator) is unlocked	Below 1.0→B+→Below 1.0	<ul style="list-style-type: none"> <li>Inspect except driver-side door lock actuator</li> <li>Inspect related harness</li> </ul>
			Other	Below 1.0	
D	Lock output	Door lock actuator	Door (door lock actuator) is locked	Below 1.0→B+→Below 1.0	<ul style="list-style-type: none"> <li>Inspect door lock actuator</li> <li>Inspect related harness</li> </ul>
			Other	Below 1.0	
F	Lock/ unlock input	Passenger-side door key cylinder switch, door lock switch, and *keyless control module	Passenger-side door is locked with key	B+→5→B+ *5→2.5→5	<ul style="list-style-type: none"> <li>Inspect passenger-side door key cylinder switch (See 09-14-6 DOOR KEY CYLINDER SWITCH INSPECTION)</li> <li>Inspect door lock switch (See 09-14-6 DOOR LOCK SWITCH INSPECTION)</li> <li>Inspect *keyless control module (See 09-14-11 KEYLESS CONTROL MODULE INSPECTION)</li> <li>Inspect related harness</li> </ul>
			Passenger-side door is unlocked with key	B+→Below 1.0→B+ *5→Below 1.0→5	
			Door lock switch is locked	B+→5→B+ *5→2.5→5	
			Door lock switch is unlocked	B+→Below 1.0→B+ *5→Below 1.0→5	
			*Transmitter UNLOCK button is pressed twice within 5 seconds	5→Below 1.0→5	
				B+	
			Other	*5	
H	Unlock input	Driver-side door key cylinder switch, and *keyless control module	Driver-side door is locked with key	B+→5→B+ *5→2.5→5	<ul style="list-style-type: none"> <li>Inspect driver-side door key cylinder switch (See 09-14-6 DOOR KEY CYLINDER SWITCH INSPECTION)</li> <li>Inspect *keyless control module (See 09-14-11 KEYLESS CONTROL MODULE INSPECTION)</li> <li>Inspect related harness</li> </ul>
			Driver-side door is unlocked with key	B+→Below 1.0→B+ *5→Below 1.0→5	
			*Transmitter LOCK button is pressed	5→2.5→5	
			*Transmitter UNLOCK button is pressed once	5→Below 1.0→5	
				B+	
			Other	*5	
I	-	-	-	-	-
J	-	-	-	-	-
K	-	-	-	-	-
L	-	-	-	-	-
M	Signal ground	GND	Under any condition: inspect for continuity to ground	Yes	-
N	Power ground	GND	Under any condition: inspect for continuity to ground	Yes	-

\* : Equipped with keyless entry system

# SECURITY AND LOCKS

## DOOR LOCK CONTROL MODULE REMOVAL/INSTALLATION

A3U091467830W02

### Note

- Because the lock section of the module is damaged easily, do not remove the module from the bracket unless replacement is necessary. Always perform an inspection of the door lock control module before removal.

1. Disconnect the negative battery cable.
2. Remove the lower panel.
3. Remove the bracket.
4. Disconnect the door lock control module connector.
5. Remove the door lock control module by prying the lock section of the upper part with a flathead screwdriver.
6. Install in the reverse order of removal.

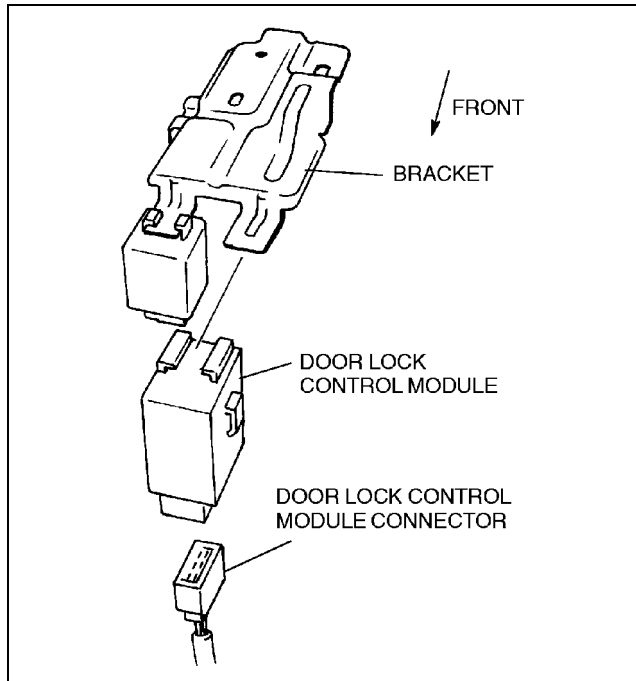

X3U914WB0

## KEYLESS ENTRY SYSTEM WIRING DIAGRAM

A3U091469000W01

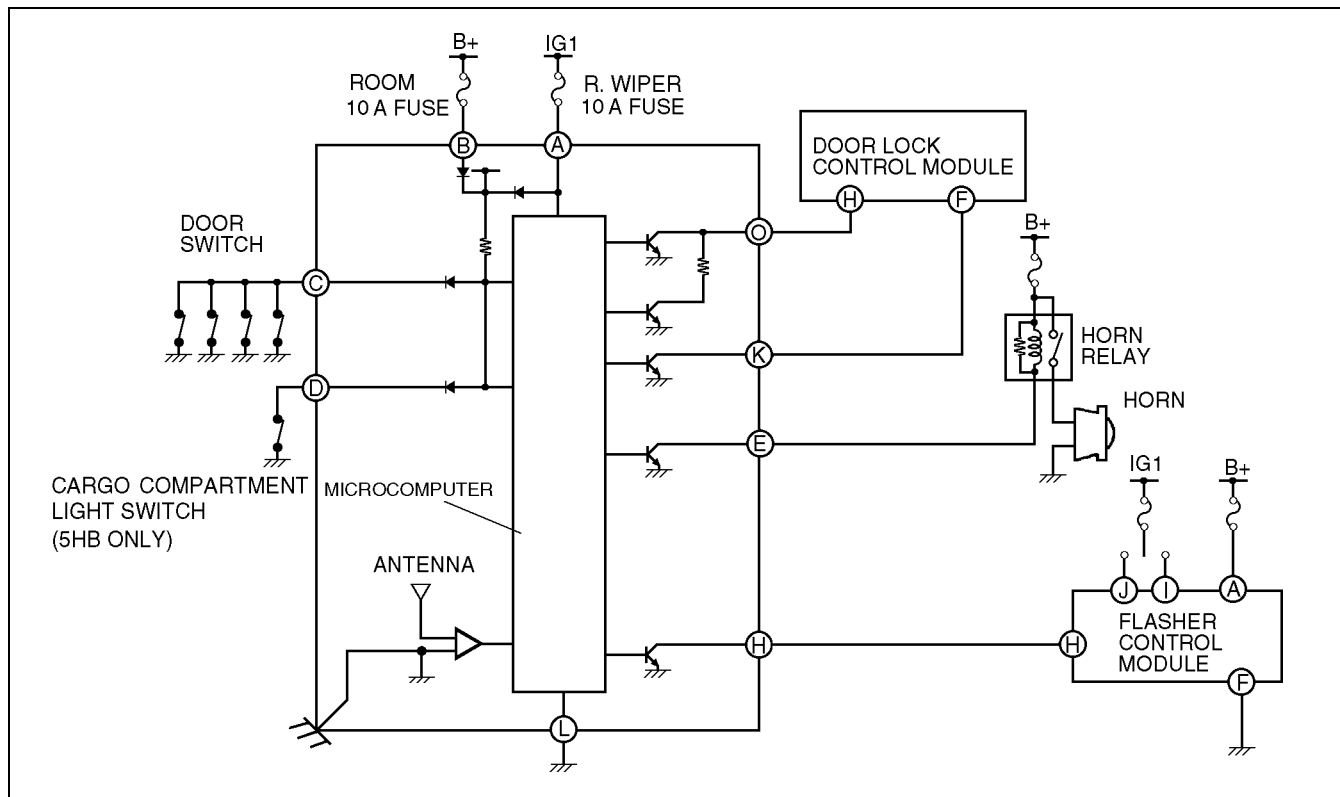

A3U0903W001

# SECURITY AND LOCKS

## KEYLESS CONTROL MODULE INSPECTION

A3U091467540W01

1. Pull out the keyless control module with the connector connected.
2. Measure the voltage at the keyless control module terminals (other than terminal L) as indicated below.
  - If not as specified, inspect the parts listed under "Action."
3. Disconnect the negative battery cable.
4. Disconnect the keyless control module connector and inspect for continuity between terminal L and bracket.
5. Inspect for continuity at terminal L as indicated below.
6. If the parts and wiring harnesses are okay but the system still does not work properly, perform the troubleshooting.

### Terminal Voltage List (Reference)

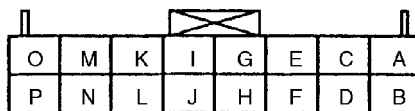

HARNESS SIDE CONNECTOR  
(VIEW FROM HARNESS SIDE)

Y3U914WA6

Terminal	Signal	Connected to	Test condition	Voltage (V)/ Continuity	Action
A	IG1	R. WIPE 10 A fuse	Ignition switch is at ON position	B+	<ul style="list-style-type: none"> <li>• Inspect R. WIPE 10 A fuse</li> <li>• Inspect related harness</li> </ul>
			Ignition switch is at LOCK or ACC position	Below 1.0	
B	Power supply	ROOM 10 A fuse	Under any condition	B+	<ul style="list-style-type: none"> <li>• Inspect ROOM 10 A fuse</li> <li>• Inspect related harness</li> </ul>
C	Door open/ closed	Door switch	Any door is open (any door switch is on)	Below 1.0	<ul style="list-style-type: none"> <li>• Inspect door switches</li> <li>• Inspect related harness</li> </ul>
			All door are closed (door switches are off)	B+	
D	Liftgate open/ closed	Cargo compartment light switch	Liftgate is open (cargo compartment light switch is on)	Below 1.0	<ul style="list-style-type: none"> <li>• Inspect cargo compartment light switch</li> <li>• Inspect related harness</li> </ul>
			Liftgate is closed (cargo compartment light switch is off)	B+	
E	Horn	Horn relay	Transmitter panic button is pressed	Alternates between B+ and Below 1.0	<ul style="list-style-type: none"> <li>• Inspect transmitter</li> <li>• Inspect horn relay</li> <li>• Inspect related harness</li> </ul>
			Transmitter panic button is not pressed	B+	
F	-	-	-	-	-
G	-	-	-	-	-
H	Hazard	Flasher control module	Transmitter panic button is pressed	Alternates between B+ and Below 1.0	<ul style="list-style-type: none"> <li>• Inspect flasher control module</li> <li>• Inspect related harness</li> </ul>
			Transmitter LOCK button is pressed	B+→Below 1.0→B+	
			Transmitter UNLOCK button is pressed once	B+→Below 1.0→B+→Below 1.0→B+	
			No transmitter buttons are pressed	B+	
I	-	-	-	-	-
J	-	-	-	-	-
K	Unlock output	Door lock control module	Transmitter UNLOCK button is pressed twice within 5 seconds. (second value)	5→Below 1.0→5	<ul style="list-style-type: none"> <li>• Inspect door lock control module</li> <li>• Inspect related harness</li> </ul>
			Other	5	

## SECURITY AND LOCKS

Terminal	Signal	Connected to	Test condition	Voltage (V)/ Continuity	Action
L	Ground	GND	Under any condition: inspect for continuity to ground	Yes	-
M	-	-	-	-	-
N	-	-	-	-	-
O	Lock/unlock output	Door lock control module	Transmitter LOCK button is pressed	5→2.5→5	<ul style="list-style-type: none"> <li>• Inspect door lock control module</li> <li>• Inspect related harness</li> </ul>
			Transmitter UNLOCK button is pressed once	5→Below 1.0→5	
			No transmitter buttons are pressed	5	
P	-	-	-	-	-

### KEYLESS CONTROL MODULE REMOVAL/INSTALLATION

A3U091467540W02

#### 4SD

1. Disconnect the negative battery cable.
2. Remove the rear package trim.
3. Disconnect the keyless control module connector.
4. Remove the nut and bolt to remove the keyless control module and the bracket as a module.

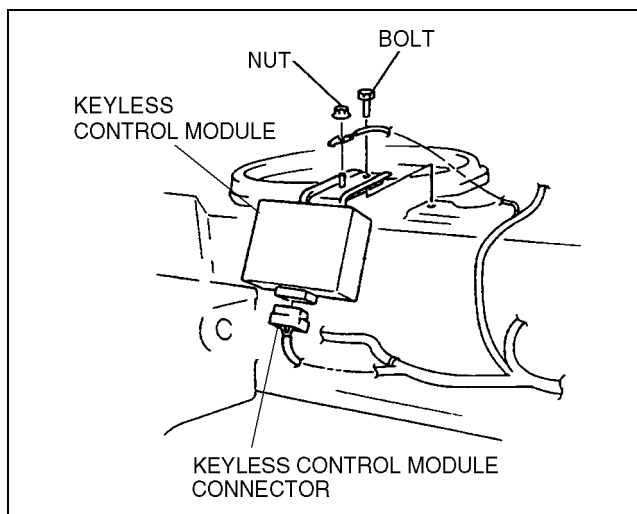

Y3E7718W002

5. Remove the screw.
6. Push the stopper using a small driver, and remove the bracket.
7. Install in the reverse order of removal.

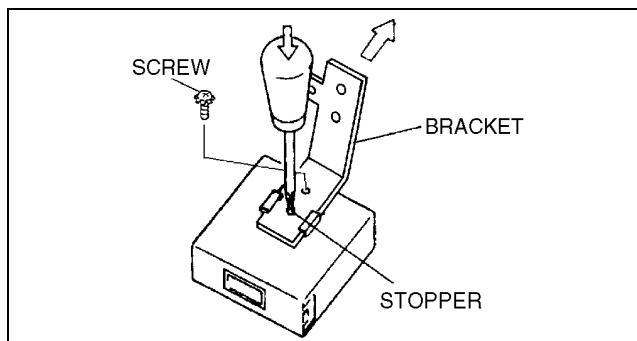

Y3E7718W003

## SECURITY AND LOCKS

### 5HB

1. Disconnect the negative battery cable.
2. Disconnect the keyless control module connector. (under driver's side dash)
3. Remove the bolt to remove the keyless control module and the bracket as a module.

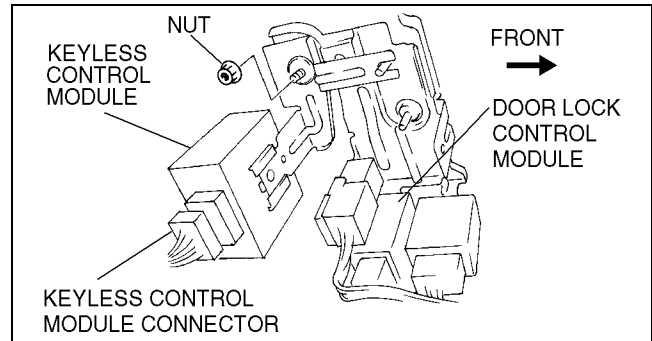

A3U0914W007

4. Remove the screw.
5. Push the stopper using a small driver, and remove the bracket.
6. Install in the reverse order of removal.

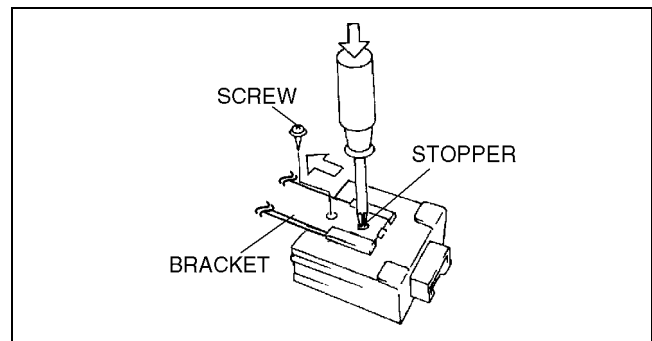

A3U0914W005

09-14

# SECURITY AND LOCKS

## KEYLESS CONTROL MODULE ID CODE CHANGE

A3U091467540W03

- When programming the ID code into a transmitter, verify that other transmitters are not being operated in the vicinity.
- Program the ID code as indicated in the procedure below.

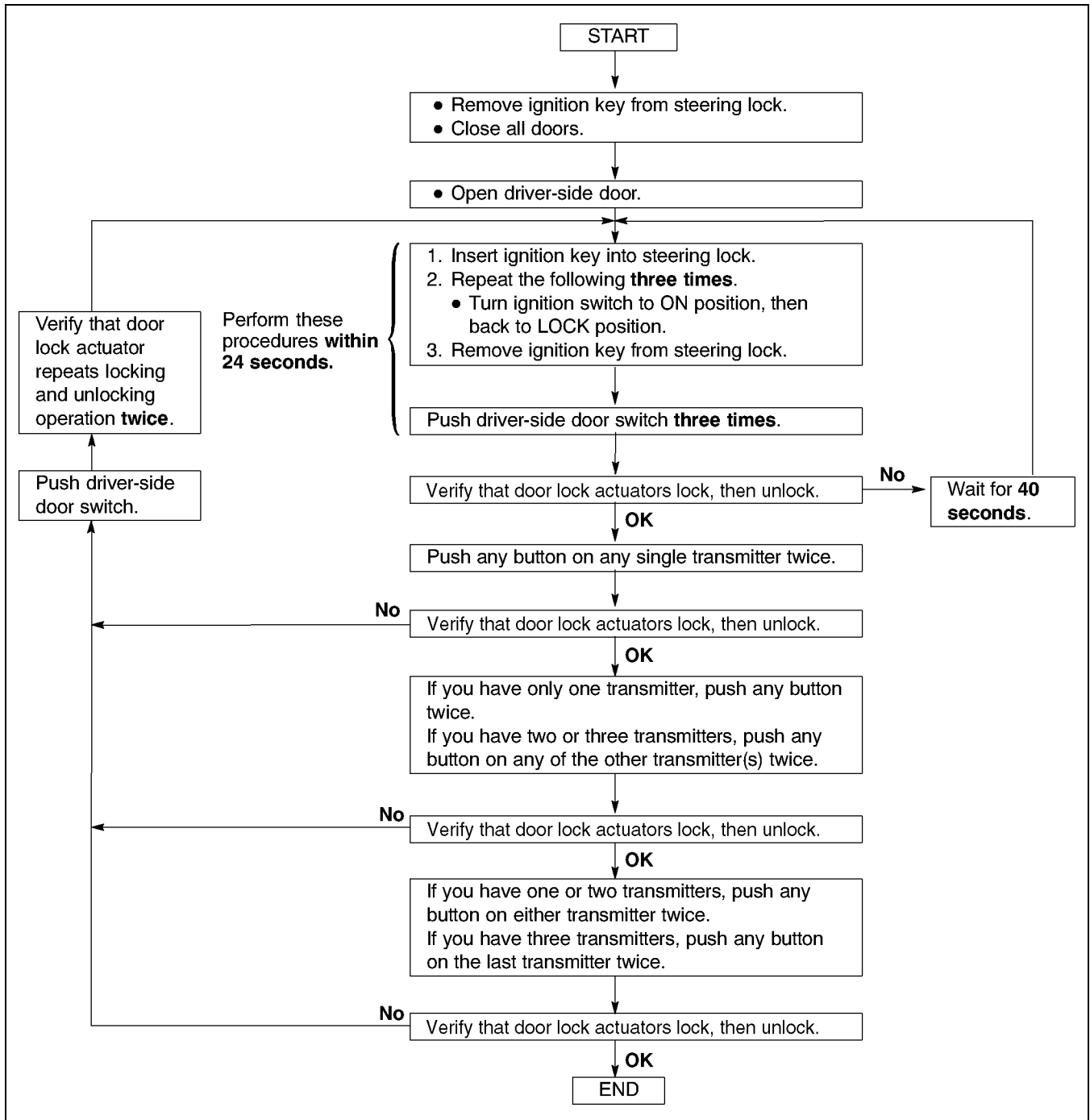

YLE7718W010

# SECURITY AND LOCKS

## TRANSMITTER BATTERY INSPECTION

A3U091467543W01

### Caution

- Since the battery voltage does not drop fully if the button is pushed for only 4 seconds or less, it cannot be properly examined to see whether it is good or bad. Always push the button for 5 seconds.

### Note

- Since a correct measurement cannot be obtained if the battery temperature is low, make sure the battery has been at **18 °C {64 °F} or more** for **at least 30 minutes** before reinspecting when a measurement value is under the standard voltage.

1. Remove the transmitter cover.
2. Apply the circuit tester leads to the positions as indicated in the figure.

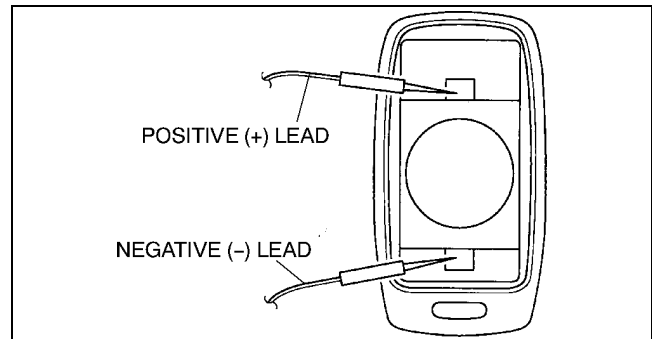

YDE7718W003

3. While pressing the battery as shown in the figure, press the LOCK and UNLOCK buttons on the transmitter at the same time to start measurement of the voltage.
4. Release the buttons after **5 seconds**.
5. Verify that the minimum voltage is the standard voltage or more for **10 seconds** after starting measurement.
  - If the voltage is under the standard voltage, replace the battery.

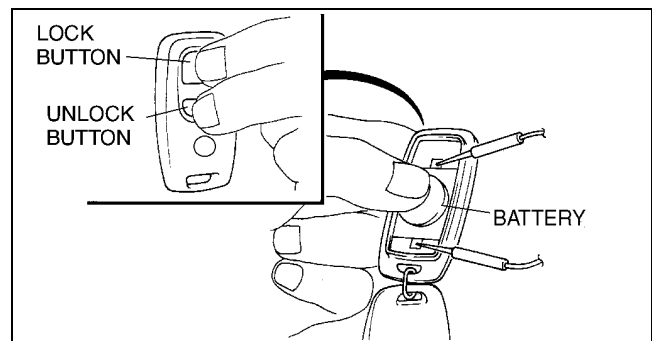

Z3U0914W006

**Standard voltage**  
**2.7 V**

09-14

## TRANSMITTER BATTERY REPLACEMENT

1. Insert a small flathead screwdriver into the slot and gently pry open the transmitter.

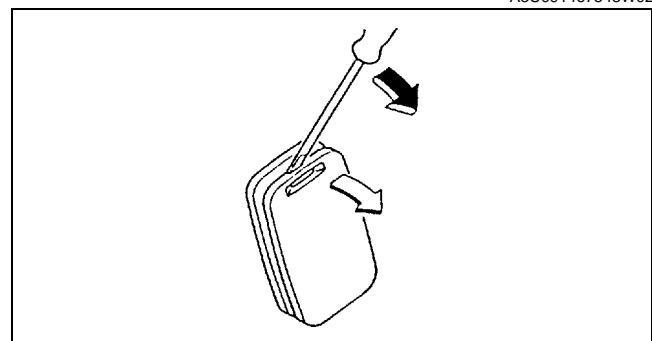

YMU914WAS

A3U091467543W02



## SECURITY AND LOCKS

2. Press the portion of the battery indicated by A and remove the battery.
3. Install a new battery (CR2025 or the equivalent) into the front portion of the holder with the positive pole (+) facing up. Press on the B portion of the battery to set the battery.
4. Align the front and back covers and snap the transmitter shut.

**Battery specification**  
Lithium CR2025 × 1

**Note**

- The batteries will last about **2 years** when used **10 times** a day.

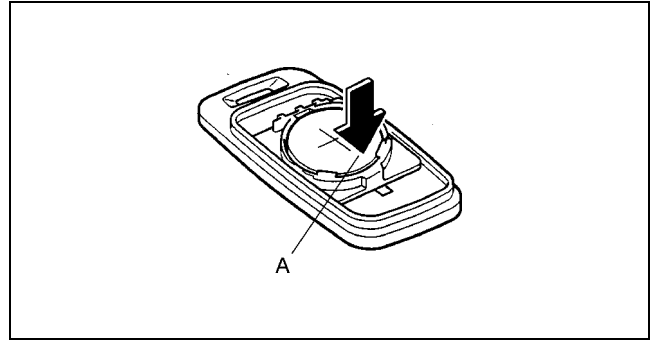

YDE7718W001

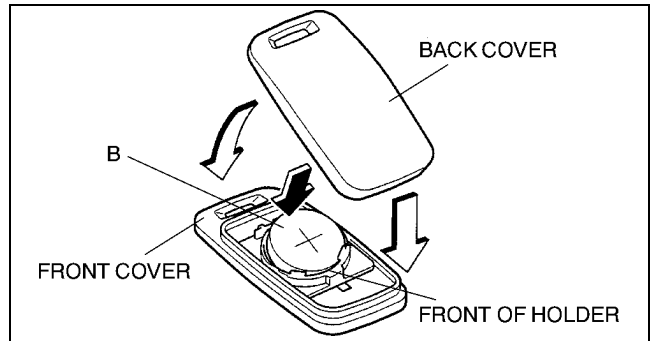

YDE7718W002

### FUEL-FILLER LID AND OPENER REMOVAL/INSTALLATION

A3U091456890W01

1. To remove the fuel-filler lid opener, remove the left side trunk side trim.
2. To remove the fuel-filler lid opener cable, perform the following.
  - (1) Remove the driver's seat. (See 09-13-1 FRONT SEAT REMOVAL/INSTALLATION.)
  - (2) Remove the driver-side front and rear scuff plate.
  - (3) Remove the driver-side B-pillar lower trim.
  - (4) Remove the driver's seat belt lower anchor.
  - (5) Remove the driver-side tire house trim.
  - (6) Remove the driver-side trunk side trim.
  - (7) Turn the floor covering over.
3. Install in the reverse order of removal.
4. Remove in the order indicated in the table.
5. Adjust the fuel-filler lid. (See 09-10-1 FUEL-FILLER LID ADJUSTMENT.)

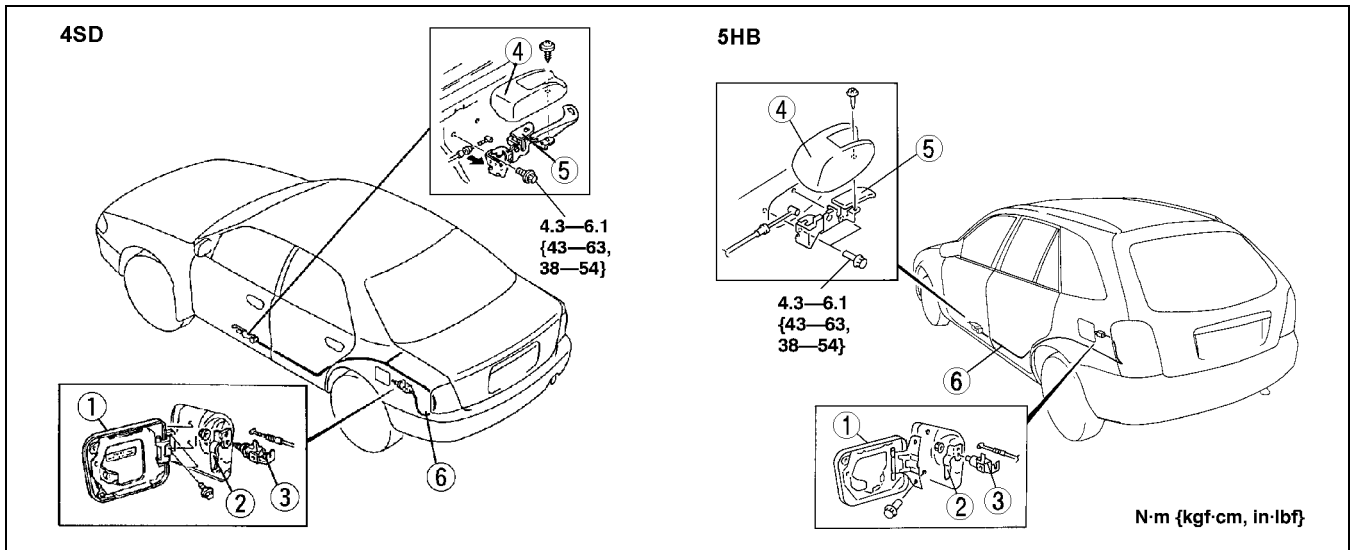

A3U0914W001

1	Fuel-filler lid
2	Lift spring
3	Fuel-filler lid opener

4	Cover
5	Fuel-filler lid opener lever
6	Fuel-filler lid opener cable

# SECURITY AND LOCKS

## HOOD LOCK AND OPENER REMOVAL/INSTALLATION

1. Remove in the order indicated in the table.

1	Hood lock
2	Hood release lever
3	Hood release cable

2. Install in the reverse order of removal.

A3U091456620W01

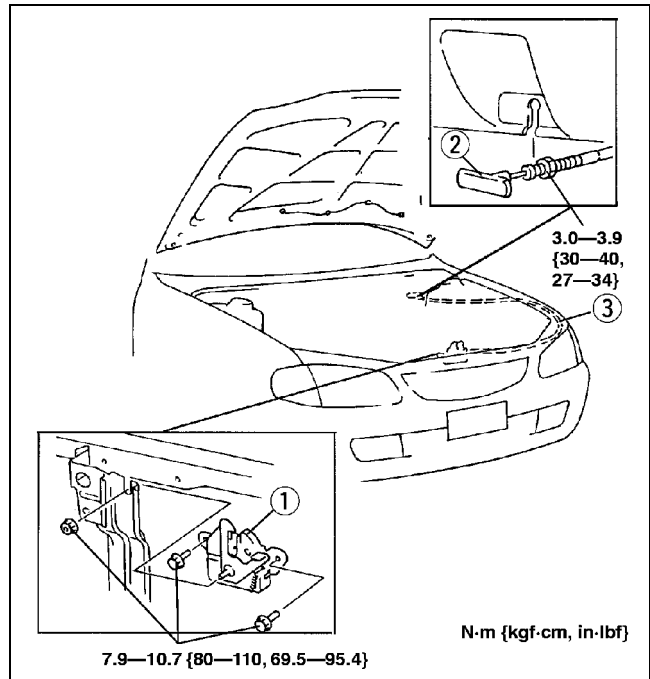

X3U914WB2

## TRUNK LID LOCK REMOVAL/INSTALLATION

1. Disconnect the negative battery cable.  
2. Remove in the order indicated in the table.

1	Cover
2	Connector
3	Trunk lid lock
4	Trunk lid lock cylinder
5	Internal trunk lid release handle (See 09–14–17 Internal Trunk Lid Release Handle Installation Note.)
6	Rod

3. Install in the reverse order of removal.

A3U091456820W01

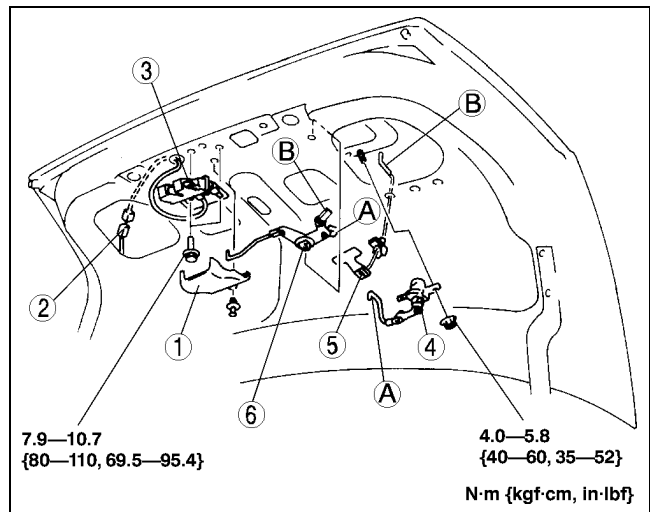

Z3U0914W008

## Internal Trunk Lid Release Handle Installation Note

### Caution

- Always keep the handle firmly attached to the holder and in the recessed position. Not securing the handle this way could allow it to snag luggage in the compartment and open the trunk lid.

1. After installation of the internal trunk lid release handle, pull the handle forward to verify the handle and rod are securely installed.  
2. Attach the handle to the holder and in the recessed position.

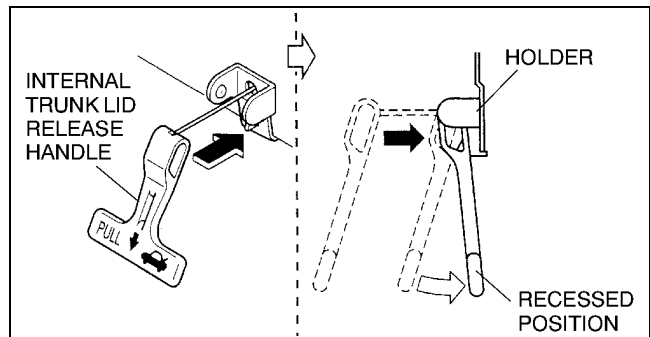

Z3U0914W009

# SECURITY AND LOCKS

## TRUNK LID OPENER REMOVAL/INSTALLATION

A3U091456822W01

1. To remove the trunk lid opener cable, perform the following.
  - (1) Remove the driver's seat. (See 09-13-1 FRONT SEAT REMOVAL/INSTALLATION.)
  - (2) Remove the driver-side front and rear scuff plate.
  - (3) Remove the driver-side B-pillar lower trim. (See 09-17-10 B-PILLAR LOWER TRIM REMOVAL.) (See 09-17-11 B-PILLAR LOWER TRIM INSTALLATION.)
  - (4) Remove the driver's seat belt lower anchor.
  - (5) Remove the passenger's side tire house trim. (See 09-17-13 TIRE HOUSE TRIM REMOVAL/INSTALLATION.)
  - (6) Remove the trunk end trim. (See 09-17-14 TRUNK END TRIM REMOVAL/INSTALLATION.)
  - (7) Turn the floor covering over.
2. Remove in the order indicated in the table.

1	Cover
2	Trunk lid opener lever
3	Trunk lid opener cable

3. Install in the reverse order of removal.
4. Adjust the trunk lid opener cable. (See 09-14-18 TRUNK LID OPENER CABLE ADJUSTMENT.)

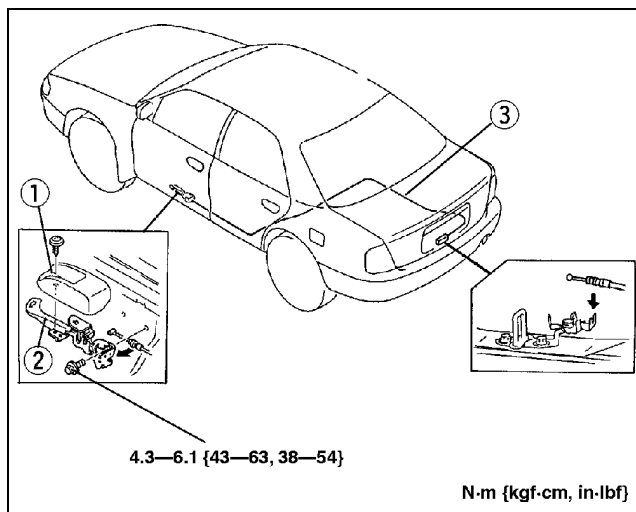

X3U914WC1

## TRUNK LID OPENER CABLE ADJUSTMENT

A3U091456822W02

1. Install the trunk lid striker to one of the three places (A, B, and C) so that the play of the trunk lid opener cable is within the specified clearance.
  - If not as specified, move to the next location.

### Clearance

a: 0.3—4.5 mm {0.02—0.17 in}

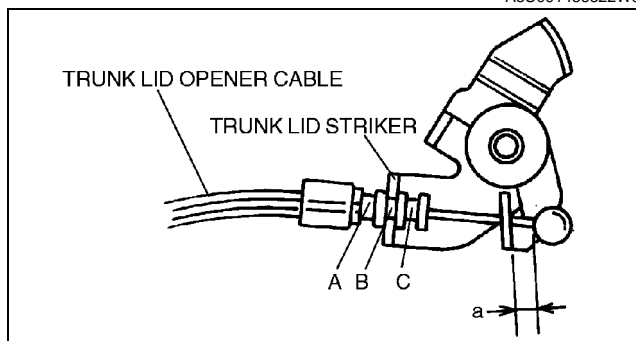

X3U914WC2

## TRUNK LID STRIKER REMOVAL/INSTALLATION

A3U091456840W01

1. Remove the trunk end trim. (See 09-17-14 TRUNK END TRIM REMOVAL/INSTALLATION.)
2. Remove the bolts, then remove the trunk lid striker.
3. Install in the reverse order of removal.
4. Adjust the trunk lid opener cable. (See 09-14-18 TRUNK LID OPENER CABLE ADJUSTMENT.)

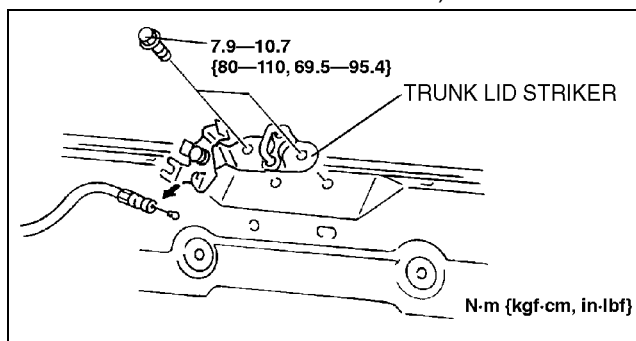

Z3U0914W004

# 09-15 SUNROOF

LOCATION INDEX .....	09-15-1	5HB .....	09-15-9
DEFLECTOR REMOVAL/INSTALLATION	09-15-2	SUNROOF MOTOR REMOVAL .....	09-15-11
4SD .....	09-15-2	SUNROOF MOTOR INSTALLATION .....	09-15-11
5HB .....	09-15-2	SUNROOF MOTOR INSPECTION .....	09-15-12
GLASS PANEL ADJUSTMENT .....	09-15-3	4SD .....	09-15-12
GLASS PANEL		5HB .....	09-15-13
REMOVAL/INSTALLATION .....	09-15-3	SUNROOF RELAY	
FRONT DRAIN HOSE REMOVAL .....	09-15-4	REMOVAL/INSTALLATION .....	09-15-14
FRONT DRAIN HOSE INSTALLATION .....	09-15-4	4SD .....	09-15-14
REAR DRAIN HOSE REMOVAL .....	09-15-4	5HB .....	09-15-14
REAR DRAIN HOSE INSTALLATION .....	09-15-5	SLIDING SUNROOF SYSTEM	
SUNROOF UNIT		WIRING DIAGRAM .....	09-15-14
REMOVAL/INSTALLATION .....	09-15-5	SUNROOF RELAY INSPECTION .....	09-15-16
SUNROOF UNIT DISASSEMBLY .....	09-15-5	4SD .....	09-15-16
4SD .....	09-15-5	5HB .....	09-15-17
5HB .....	09-15-7	SUNROOF SWITCH	
SUNROOF UNIT ASSEMBLY .....	09-15-8	REMOVAL/INSTALLATION .....	09-15-18
4SD .....	09-15-8	SUNROOF SWITCH INSPECTION .....	09-15-18

## LOCATION INDEX

A3U091501049W01

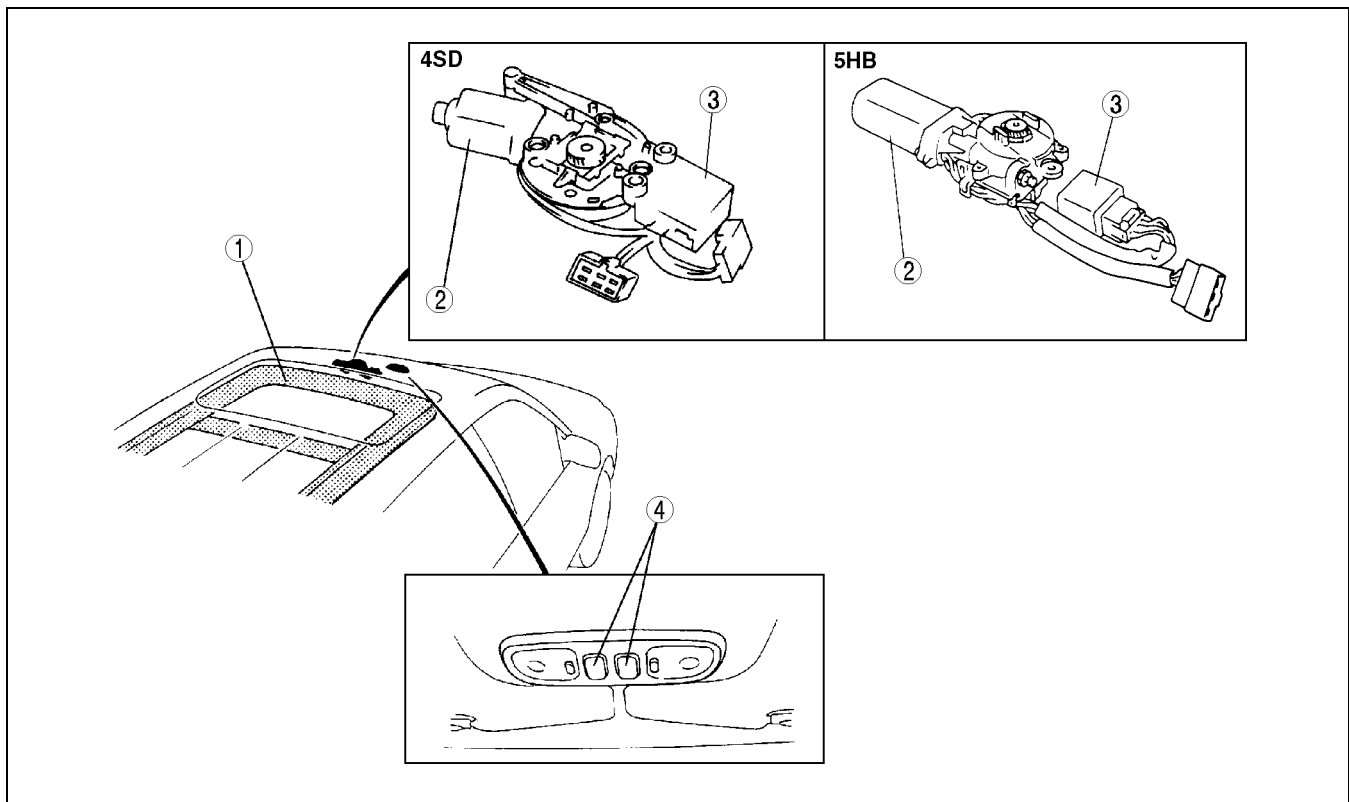

A3U0915W024

1	Sunroof unit (See 09-15-5 SUNROOF UNIT REMOVAL/INSTALLATION) (See 09-15-8 SUNROOF UNIT ASSEMBLY) (See 09-15-5 SUNROOF UNIT DISASSEMBLY)
2	Sunroof motor (See 09-15-5 SUNROOF UNIT REMOVAL/INSTALLATION)

3	Sunroof relay (See 09-15-14 SUNROOF RELAY REMOVAL/INSTALLATION) (See 09-15-16 SUNROOF RELAY INSPECTION)
4	Sunroof switch (See 09-15-18 SUNROOF SWITCH INSPECTION) (See 09-15-18 SUNROOF SWITCH REMOVAL/INSTALLATION)

# SUNROOF

A3U091569880W01

## DEFLECTOR REMOVAL/INSTALLATION

### 4SD

1. Fully open the glass panel.
2. To remove the stopper, remove the sunroof unit. (See 09-15-5 SUNROOF UNIT REMOVAL/INSTALLATION.)
3. Remove in the order indicated in the table.

1	Deflector (See 09-15-2 Deflector Removal Note)
2	Stopper

4. Install in the reverse order of removal.

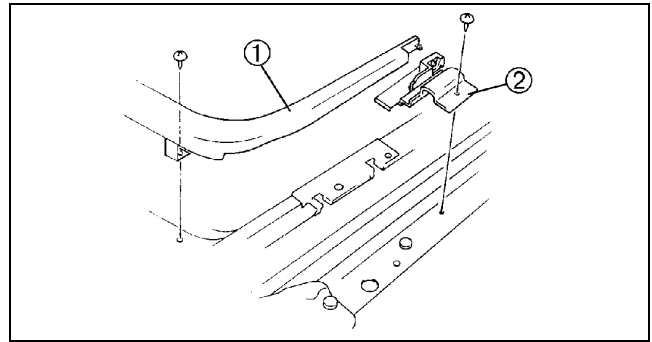

X3U915WA2

### Deflector Removal Note

1. Remove the deflector using a tape-wrapped screwdriver.

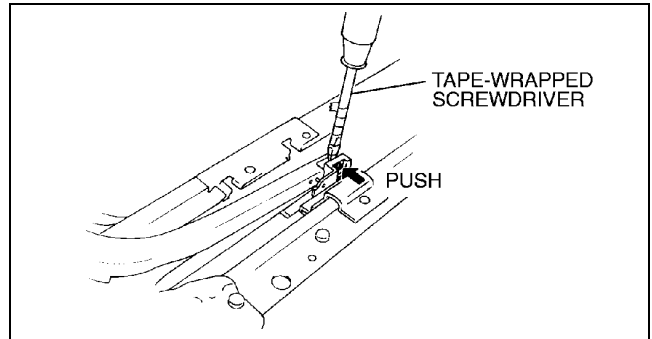

X3U915WA3

### 5HB

1. Fully open the glass panel.
2. Push the deflector inside (1) and pull it up (2) to release the stopper.
3. Slide the deflector to disengage from the hook. (3)
4. Remove the deflector.
5. Install in the reverse order of removal.

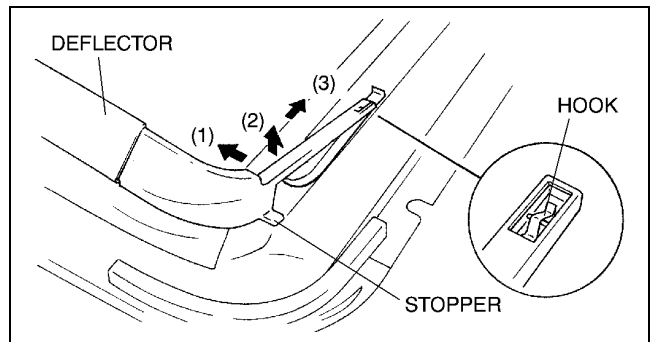

A3U0915W001

## GLASS PANEL ADJUSTMENT

A3U091569810W01

1. Fully close the glass panel.
2. Measure the gap and height between the glass panel and body.
  - If not as specified, loosen the glass panel installation screws and reposition the glass panel.

### Clearance

- a: 0.2—2.2 mm {0.008—0.086 in}**  
**b: 0 mm {0 in}**

3. Tighten the installation screws.

4. Insert a prepaid card between the weatherstrip and the body of the vehicle. Verify that the sunroof is shut tightly (there is resistance when the prepaid card is moved).
  - If the sunroof is not shut tightly, readjust by performing Steps 3 and 4.

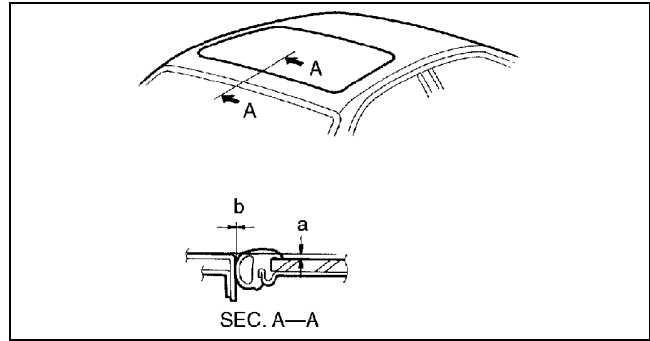

X3U915WA6

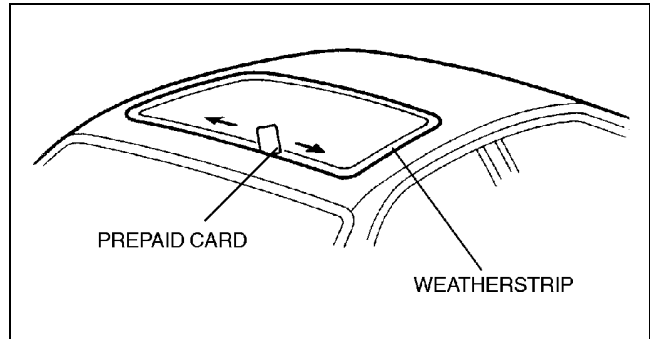

X3U915WA7

## GLASS PANEL REMOVAL/INSTALLATION

A3U091569810W02

1. Fully close the glass panel.
2. Fully open the sunshade.
3. Remove the screws, and then remove the glass panel.

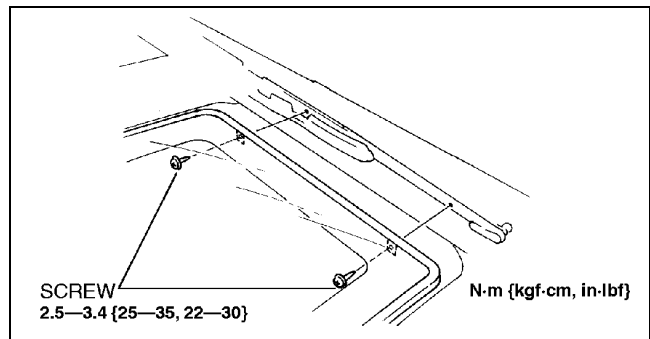

X3U915WA4

4. Peel the weatherstrip off the glass panel.
5. Install in the reverse order of removal.
6. Adjust the glass panel. (See 09-15-3 GLASS PANEL ADJUSTMENT.)

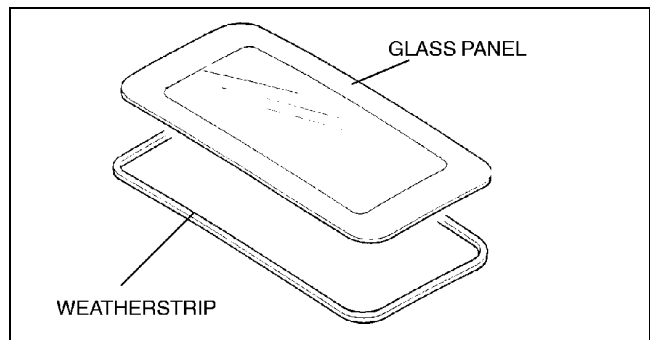

X3U915WA5

# SUNROOF

## FRONT DRAIN HOSE REMOVAL

A3U091569920W01

1. Remove the headliner. (See 09-17-16 HEADLINER REMOVAL/INSTALLATION.)
2. Disconnect the front drain hose from the sunroof frame.
3. Remove the front drain hose from the clips.
4. Pull the front drain hose into the room side.
5. Remove the front drain hose.

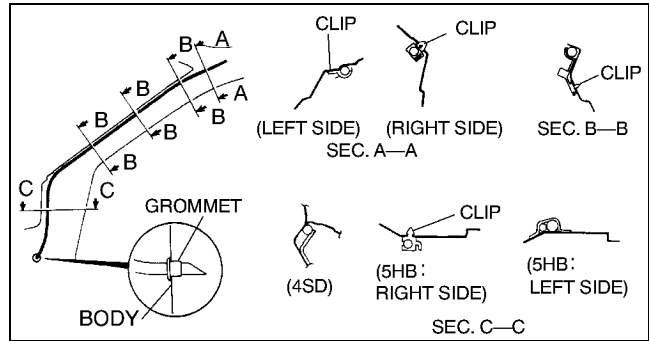

A3U0915W022

## FRONT DRAIN HOSE INSTALLATION

A3U091569920W02

### Caution

- If the front drain hose is pinched or bent anywhere, the water in the hose may not discharge and enter the inside of the vehicle. During and after installation of the trims and the headliner, always make sure there is no interference with the front drain hose. Fix any problem if found.

1. Apply soapy water to the front drain hose inserting area.
2. Insert one end of the front drain hose into the sunroof frame.
3. Install the front drain hose to the clips parallel to the pillar and free of slack.
4. Insert the front drain hose joint into the hinge pillar inner hole.
5. Install the headliner. (See 09-17-16 HEADLINER REMOVAL/INSTALLATION.)

## REAR DRAIN HOSE REMOVAL

A3U091569922W01

1. Remove the headliner. (See 09-17-16 HEADLINER REMOVAL/INSTALLATION.)
2. For 4SD, remove the trunk side trim.
3. Disconnect the rear drain hose from the sunroof frame.
4. Remove the rear drain hose from the clips.
5. Pull the rear drain hose into the room side.
6. Remove the rear drain hose.

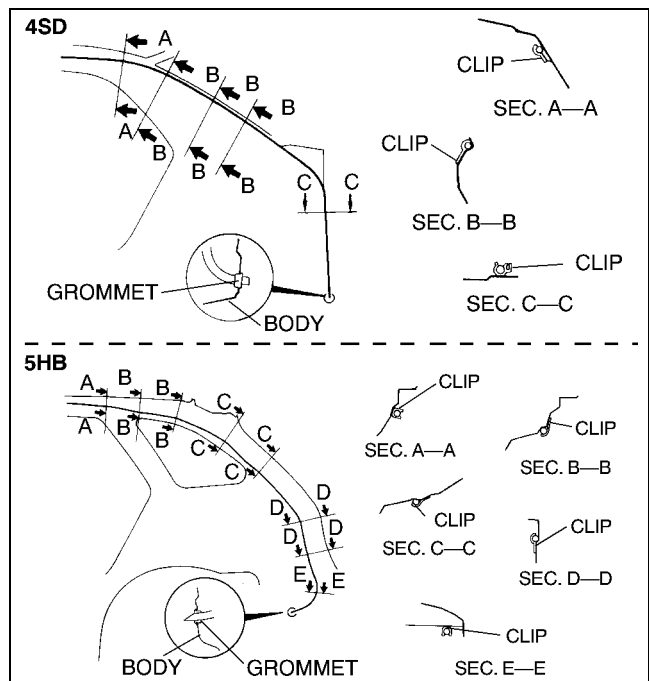

A3U0915W002

## REAR DRAIN HOSE INSTALLATION

A3U091569922W02

### Caution

- If the rear drain hose is pinched or bent anywhere, the water in the hose may not discharge and enter the inside of the vehicle. During and after installation of the trims and the headliner, always make sure there is no interference with the rear drain hose. Fix any problem if found.

1. Apply soapy water to the rear drain hose inserting area.
2. Insert one end of the rear drain hose into the sunroof frame.
3. Install the rear drain hose to the clips parallel to the pillar and free of slack.
4. Insert the rear drain hose joint into the rear pillar inner hole.
5. Install the trunk side trim. (See 09-17-15 TRUNK SIDE TRIM REMOVAL/INSTALLATION.)
6. Install the headliner. (See 09-17-16 HEADLINER REMOVAL/INSTALLATION.)

## SUNROOF UNIT REMOVAL/INSTALLATION

A3U091569850W01

1. Disconnect the negative battery cable.
2. Remove the headliner. (See 09-17-16 HEADLINER REMOVAL/INSTALLATION.)
3. Remove the glass panel.
4. Disconnect the front and rear drain hoses from the sunroof frame.
5. Remove the roof harness from the sunroof frame.

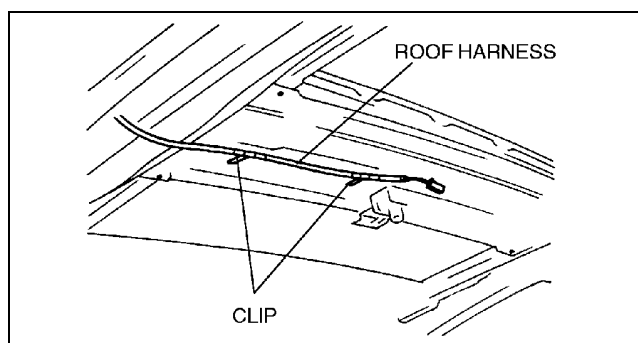

X3U915WAA

6. Remove the bolts and nuts, and then remove the sunroof unit.
7. Install in the reverse order of removal.
8. Adjust the glass panel. (See 09-15-3 GLASS PANEL ADJUSTMENT.)

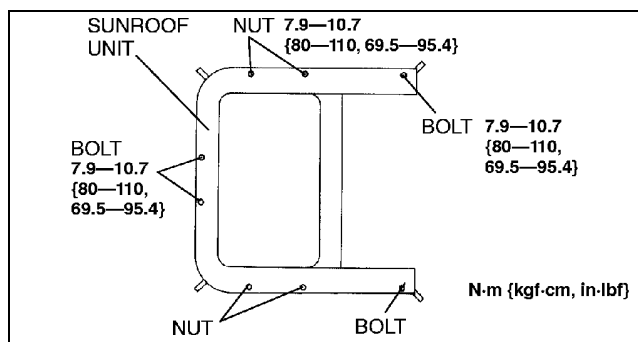

X3U915WAB

## SUNROOF UNIT DISASSEMBLY

A3U091569850W02

### 4SD

1. Remove the screws, and then remove the drip rail.

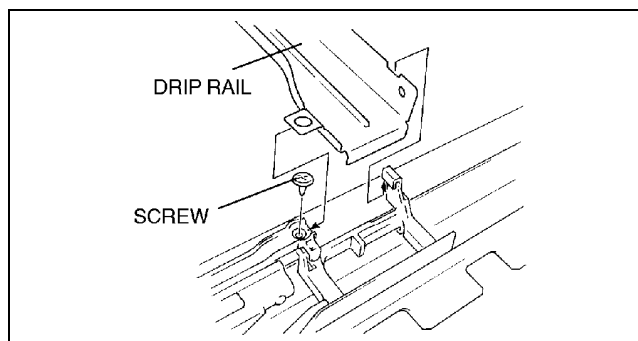

X3U915WAC



## SUNROOF

2. Remove the sunshade stopper.
3. Slide the sunshade backward, and remove it from the sunroof frame.

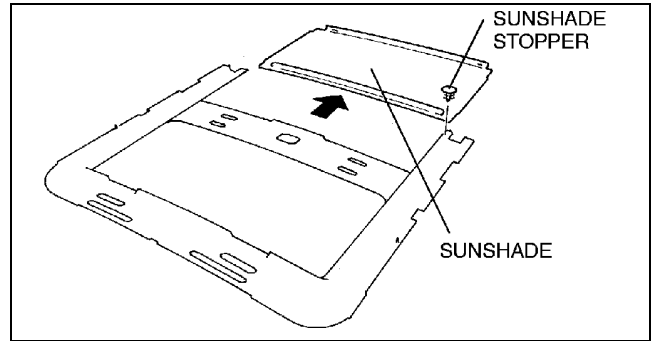

X3U915WAD

4. Remove the screws, and then remove the rear drip.

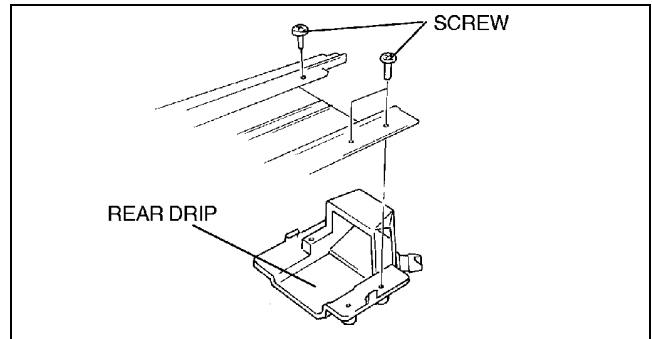

X3U915WAE

5. Slide the drip shoe backward, and remove it from the sunroof frame.
6. Remove the sunroof motor.

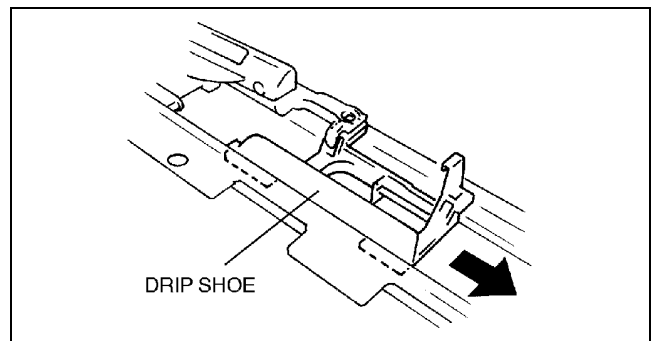

X3U915WAF

7. Remove the stopper screw.
8. Slide the guide backward, and remove it from the sunroof frame.
9. Remove the deflector.

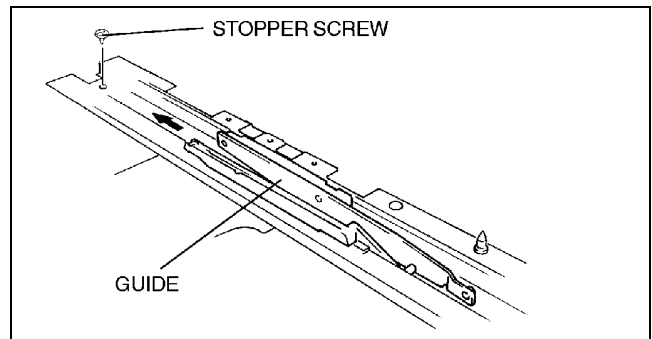

X3U915WAG

# SUNROOF

## 5HB

1. Bend the hook of the decoration link backward to remove the drip rail.

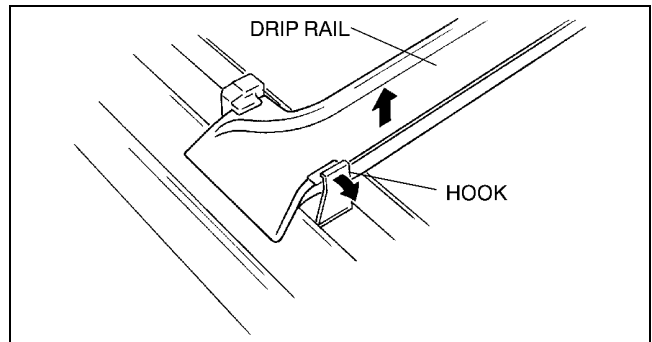

A3U0915W003

2. Remove the sunshade stopper.
3. Slide the sunshade backward, and remove it from the sunroof frame.

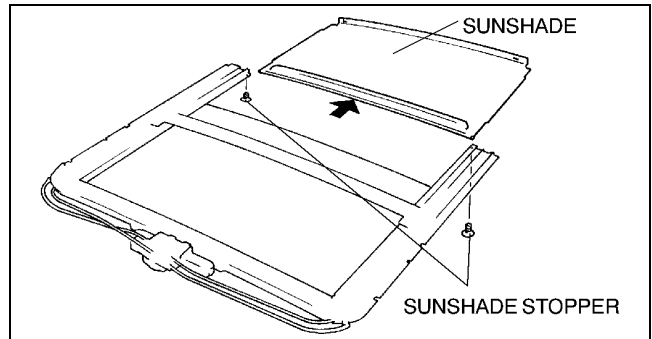

A3U0915W004

4. Remove the screw, and then remove the guide stopper.

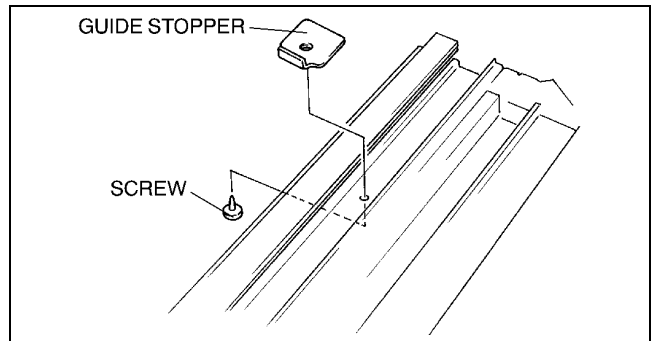

A3U0915W005

5. Remove the lock washer using a tape-wrapped screwdriver.
6. Slide the decoration link backward, and remove it from the sunroof frame.
7. Remove the sunroof motor.

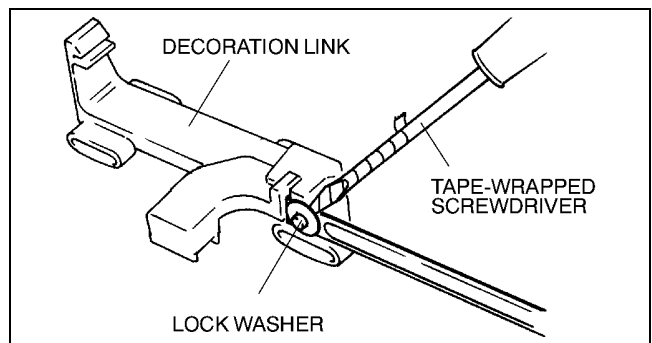

A3U0915W006

09-15

# SUNROOF

- Slide the guide backward, and remove it from the sunroof frame.

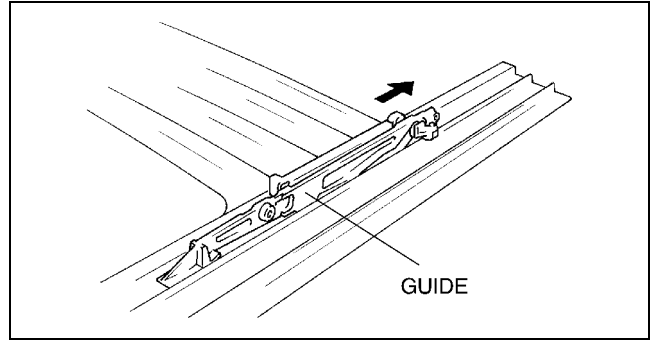

A3U0915W007

- Remove the screws.
- Slide the drive unit forward, and remove it from the sunroof frame.
- Remove the deflector.
- Remove the sunroof relay.

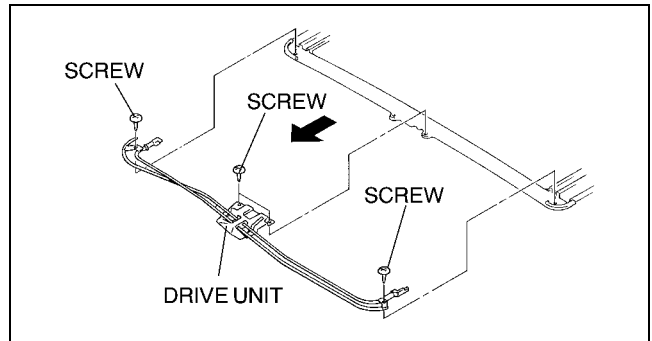

A3U0915W008

## SUNROOF UNIT ASSEMBLY

### 4SD

- Install the deflector.
- Slide the guide forward, and install it to the sunroof frame.
- Install the stopper screw.
- Move the guide by hand until it is tilted up position.

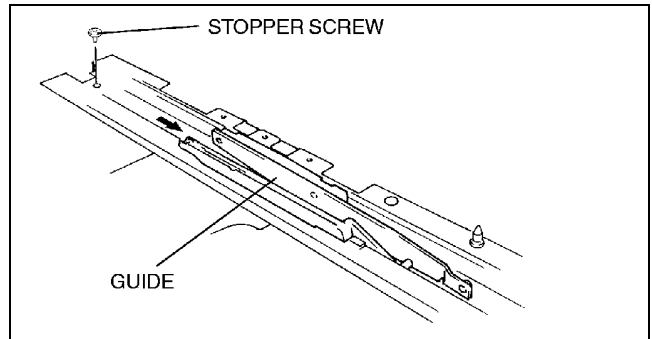

X3U915WAH

- Move the link built into the guide by hand until it is aligned with mark A and mark B.
- Install the sunroof motor.

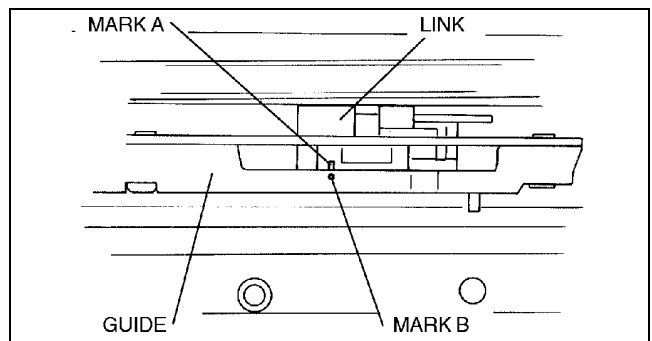

X3U915WAJ

# SUNROOF

- Slide the drip shoe forward, and install it to the sunroof frame.
- Use IPA (Isopropyl alcohol) to remove any excess repair sealant.

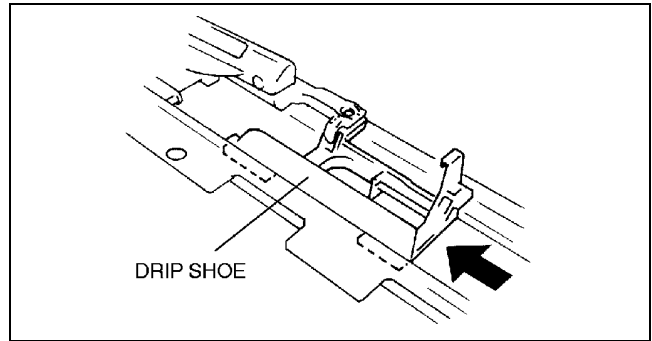

X3U915WAK

- Install the screws, and then install the rear drip.

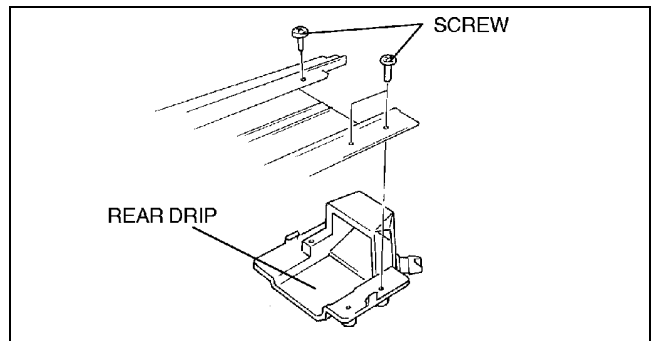

X3U915WAL

- Slide the sunshade forward, and install it to the sunroof frame.
- Install the sunshade stopper.

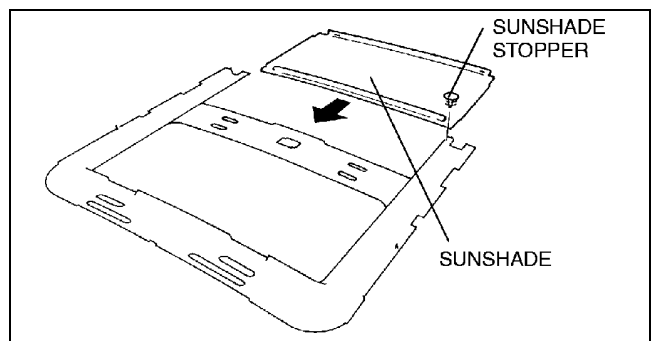

X3U915WAM

- Install the screws, and then install the drip rail.

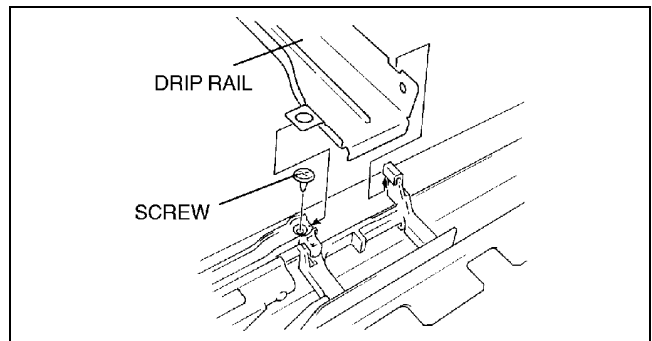

X3U915WAN

## 5HB

- Install the sunroof relay.
- Install the deflector.
- Slide the drive unit backward, and install it to the sunroof frame.

# SUNROOF

4. Install the screws.

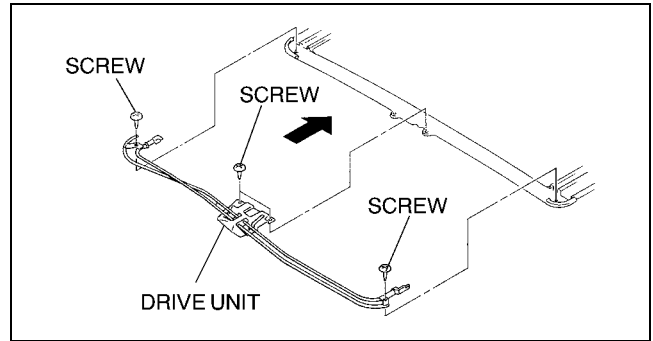

A3U0915W009

5. Slide the guide forward, and install it to the sunroof frame.

6. Move the guide by hand until it is in the tilted up position.

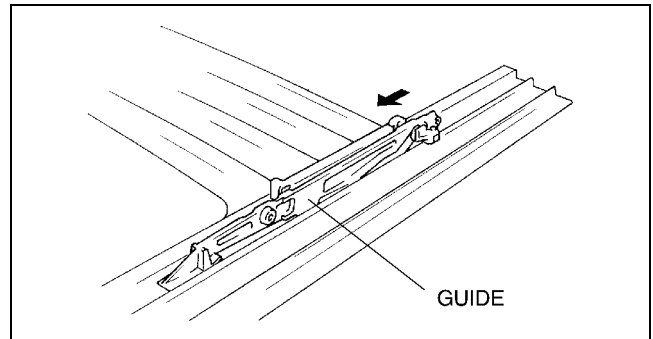

A3U0915W010

7. Move the guide by hand until notch comes between mark A and mark B.

8. Install the sunroof motor.

9. Slide the decoration link forward, and install it to the sunroof frame.

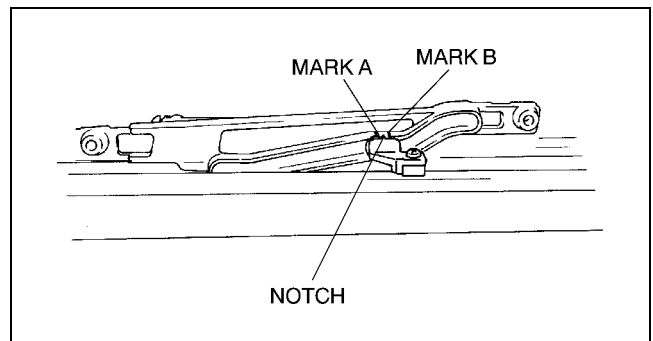

A3U0915W011

10. Install the lock washer.

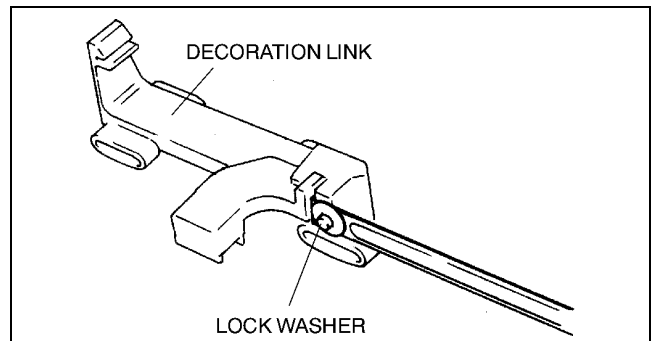

A3U0915W012

11. Install the screw, and then install the guide stopper.

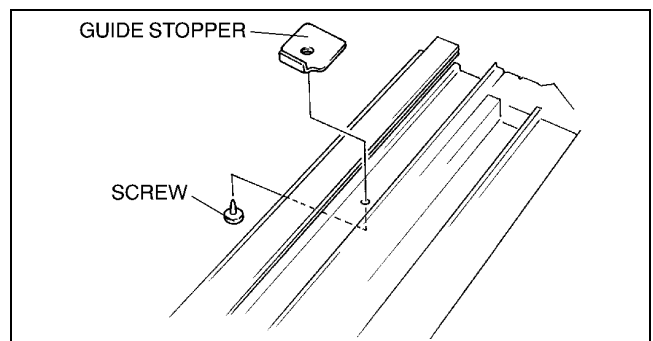

A3U0915W005

## SUNROOF

- Slide the sunshade forward, and install it to the sunroof frame.
- Install the sunshade stopper.

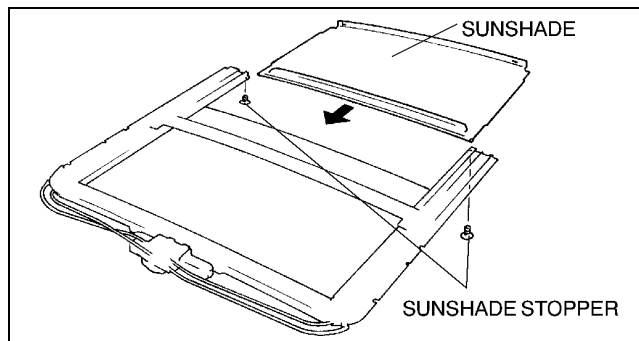

A3U0915W013

- Bend the hook of the decoration link backward to install the drip rail.

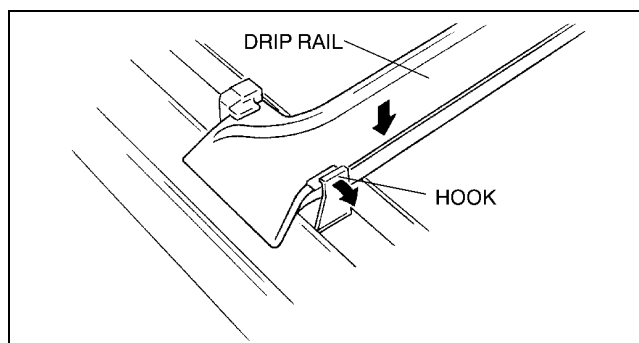

A3U0915W014

### SUNROOF MOTOR REMOVAL

- Disconnect the negative battery cable.
- Remove the headliner. (See 09-17-16 HEADLINER REMOVAL/INSTALLATION.)
- Disconnect the connector.
- Remove the screws, and then remove the sunroof motor.

A3U091569870W01

09-15

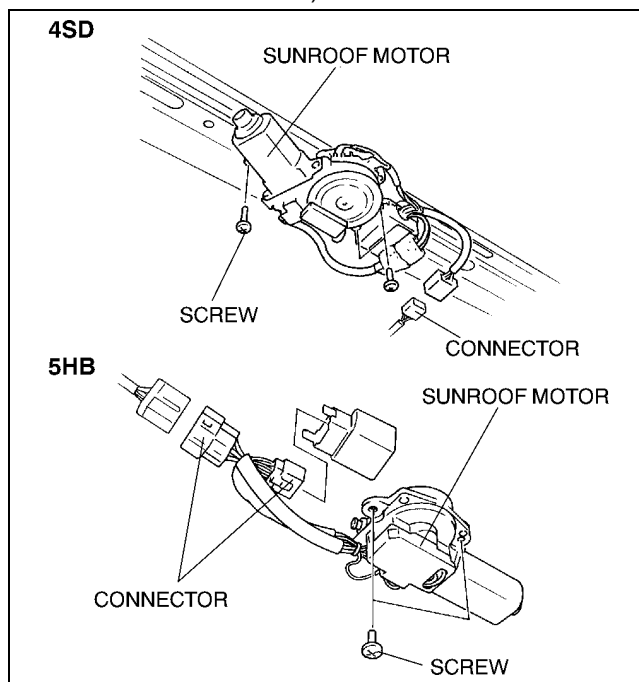

A3U0915W015

### SUNROOF MOTOR INSTALLATION

- Connect the sunroof motor connector.
- Connect the sunroof switch connector.
- Connect the negative battery cable.
- Turn the ignition switch to ON position.
- Press the CLOSE side of the slide switch until the sunroof motor stops.
- Disconnect the sunroof switch connector.
- Install the screws, and then install the sunroof motor.
- Install the headliner. (See 09-17-16 HEADLINER REMOVAL/INSTALLATION.)

A3U091569870W02

## SUNROOF MOTOR INSPECTION

### 4SD

#### Motor

1. Remove the sunroof motor.
2. Apply battery positive voltage to the sunroof motor terminals and inspect the operation of the sunroof motor.
  - If not as specified, replace the sunroof motor.

Connection		Motor operation
2A	2B	
B+	GND	Turn left (Slide close/Tilt up)
GND	B+	Turn right (Slide open/Tilt down)

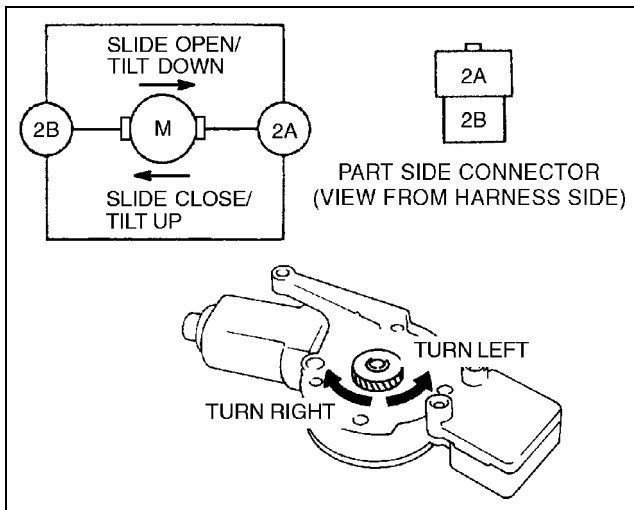

A3U0915W025

#### Limit Switch

1. Remove the headliner. (See 09-17-16 HEADLINER REMOVAL/INSTALLATION.)
2. Verify the glass panel position.
3. Disconnect the connector.
4. Inspect for continuity between the sunroof motor terminals using an ohmmeter.
  - If not as specified, replace the sunroof motor.

○—○ : Continuity

Glass panel position	Terminal						
	1A	1B	1C	1D	1E	1F	GND
Fully open	○—○		○—○				○—○
Fully closed	○—○	○—○			○—○		○—○
Fully tilt up	○—○			○—○			○—○

X3U915WAR

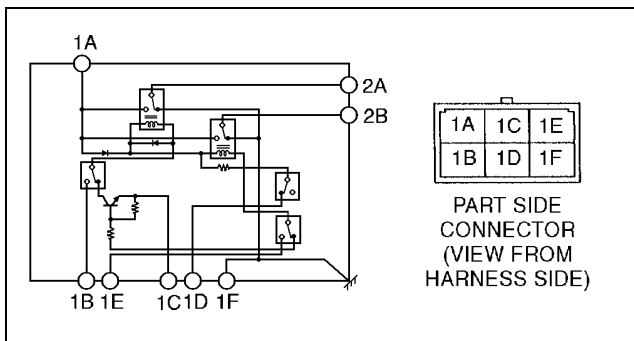

Y3U915WA1

## 5HB

### Motor

1. Remove the sunroof motor.
2. Apply battery positive voltage to the sunroof motor terminals and inspect the operation of the sunroof motor.
  - If not as specified, replace the sunroof motor.

Connection		Motor operation
1A	1I	
B+	GND	Turn right (Slide open/Tilt down)
GND	B+	Turn left (Slide close/Tilt up)

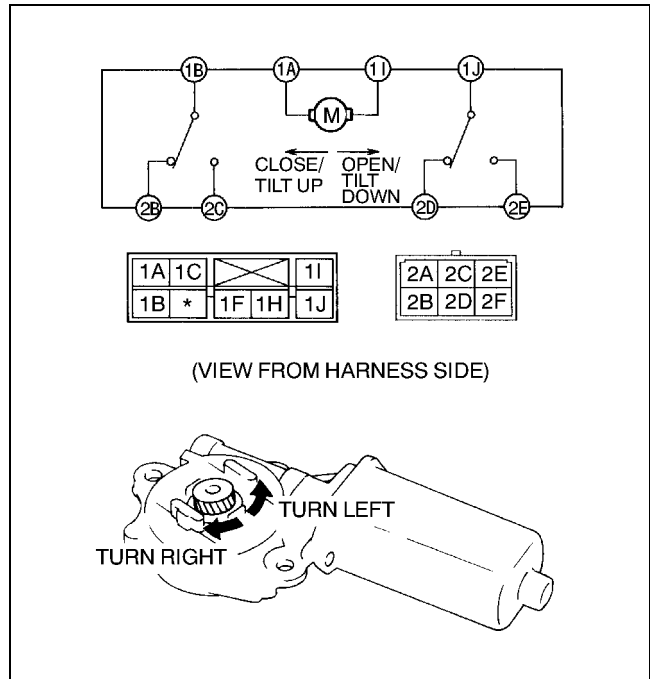

A3U0915W017

### Limit Switch

1. Remove the headliner. (See 09-17-16 HEADLINER REMOVAL/INSTALLATION.)
2. Verify the glass panel position.
3. Disconnect the connector.
4. Inspect for continuity between the sunroof motor terminals using an ohmmeter.
  - If not as specified, replace the sunroof motor.

○—○ : Continuity

Glass panel position	Terminal								
	2B	2C	2D	2E	1B	1J	2F	1H	Body GND
Fully open		○	○	○	○	○	○	○	○
Fully closed	○		○	○	○	○	○	○	○
Fully tilted up	○			○	○	○	○	○	○

A3U0915W018

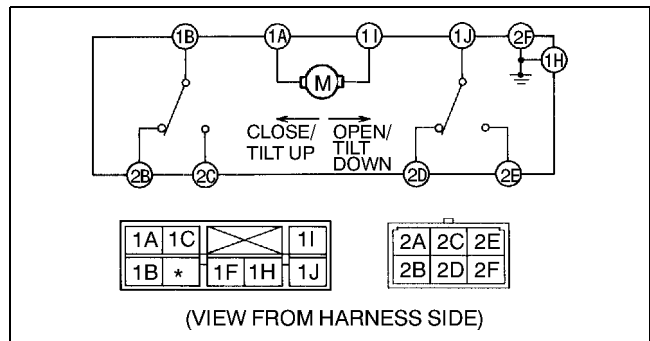

A3U0915W019



# SUNROOF

## SUNROOF RELAY REMOVAL/INSTALLATION

A3U091569873W01

4SD

### Note

- Sunroof relay is built in the sunroof motor.

5HB

1. Disconnect the negative battery cable.
2. Remove the headliner. (See 09-17-16 HEADLINER REMOVAL/INSTALLATION.)
3. Pull the sunroof relay from the sunroof frame.
4. Disconnect the connector, and remove the sunroof relay.
5. Install in the reverse order of removal.

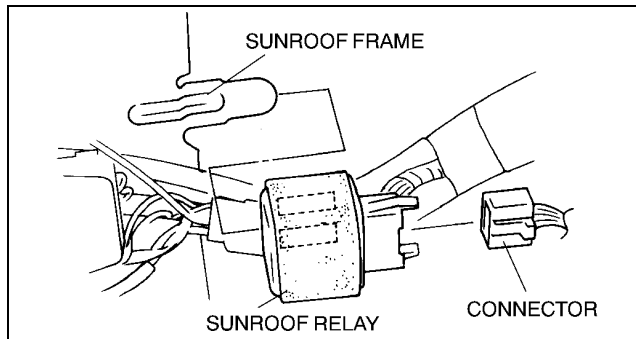

A3U0915W020

## SLIDING SUNROOF SYSTEM WIRING DIAGRAM

A3U091501049W02

4SD

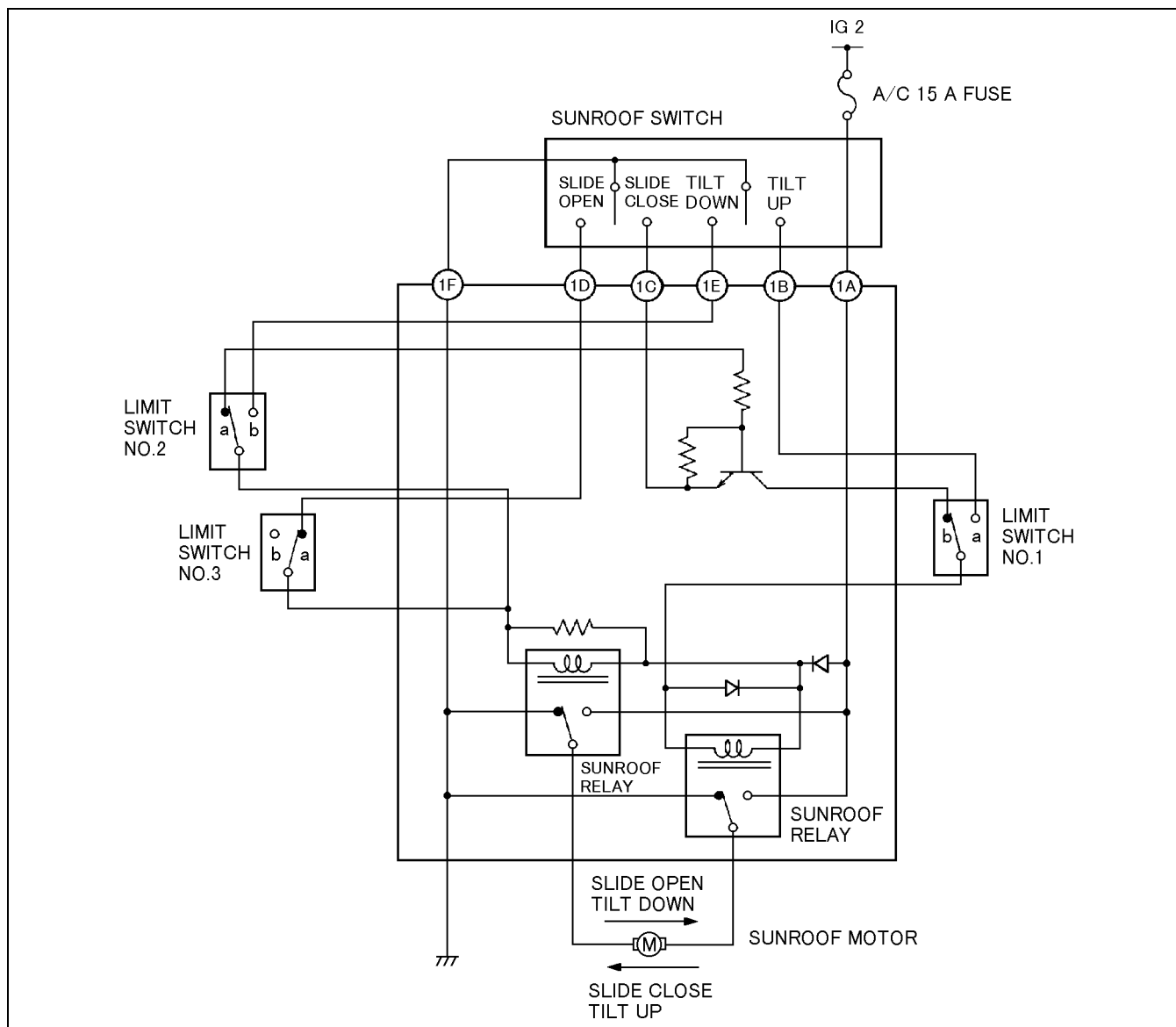

A3U0915W027

# SUNROOF

5HB

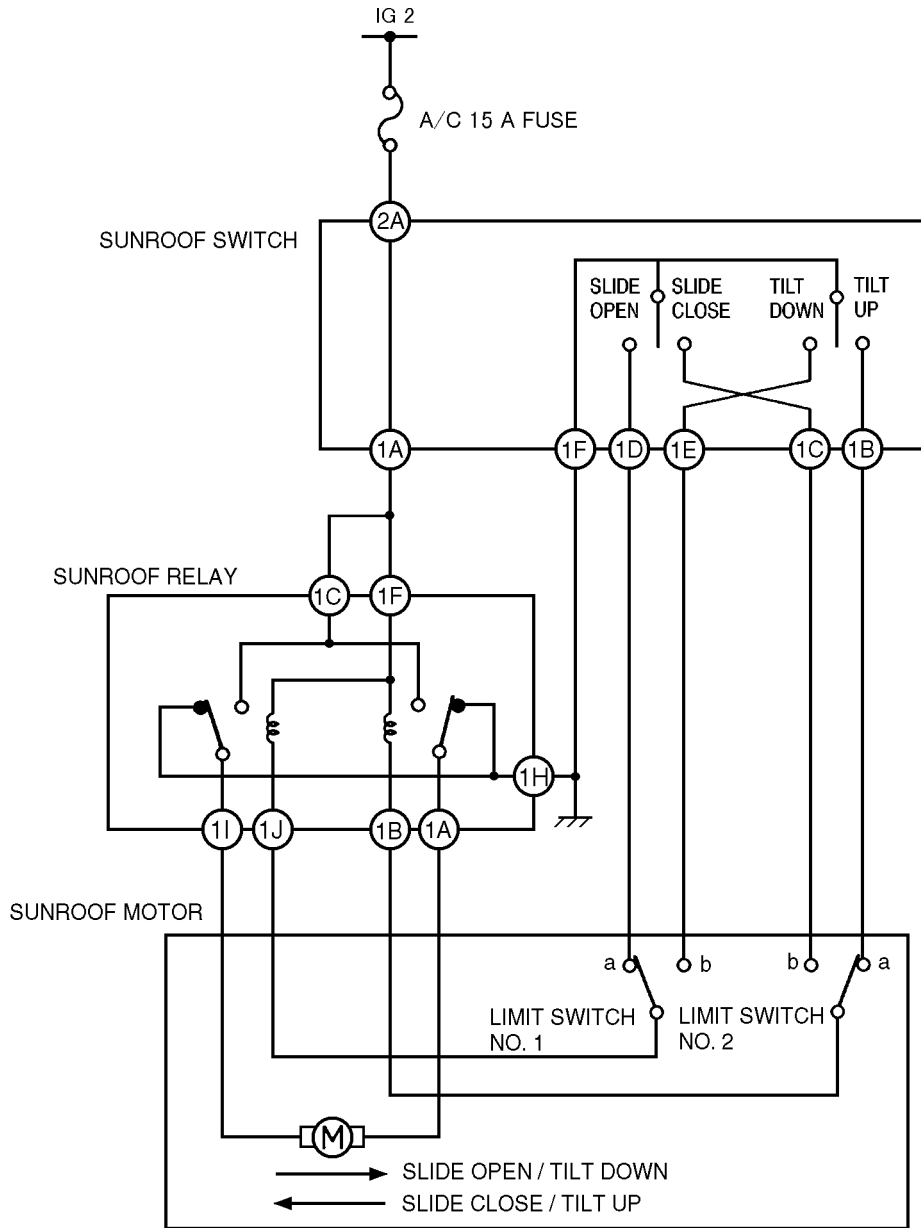

09-15

A3U0915W026

# SUNROOF

## SUNROOF RELAY INSPECTION

A3U091569873W02

### 4SD

1. Remove the headliner. (See 09–17–16 HEADLINER REMOVAL/INSTALLATION.)
2. Connect the sunroof switch connector.
3. Connect the negative battery cable.
4. Measure the voltage at the sunroof relay terminals as indicated below.
5. Disconnect the sunroof relay connector before inspecting for continuity at terminal 1F.
  - If not as specified, inspect the parts listed under “Action” and the related wiring harnesses.
  - If the parts and wiring harnesses are okay but the system still does not work properly, replace the sunroof relay.

### Terminal voltage list (Reference)

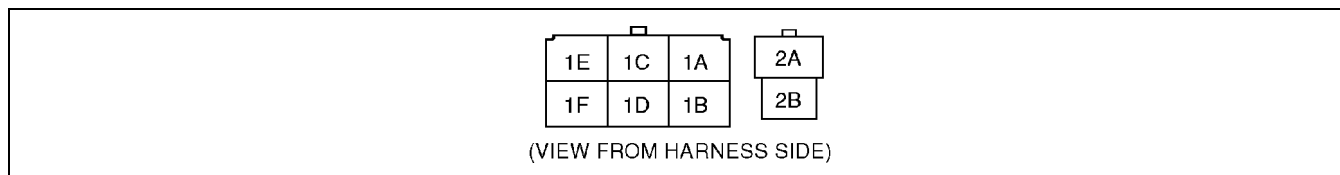

A3U0915W023

Terminal	Signal	Connected to	Test condition	Voltage (V)/ Continuity	Action
1A	IG2	Sunroof motor	IG SW is at ON position.	B+	<ul style="list-style-type: none"> <li>• Inspect A/C 15 A fuse</li> <li>• Inspect sunroof switch (See 09–15–18 SUNROOF SWITCH INSPECTION)</li> <li>• Inspect related harness</li> </ul>
			Other	0	
1B	Tilt up	Sunroof switch	Sunroof is tilting up. (Including position when fully closed)	B+	<ul style="list-style-type: none"> <li>• Inspect sunroof switch (See 09–15–18 SUNROOF SWITCH INSPECTION)</li> <li>• Inspect related harness</li> </ul>
			Other	0	
1C	Slide close	Sunroof switch	Sunroof is closing. (Including position when fully closed and open)	B+	<ul style="list-style-type: none"> <li>• Inspect sunroof switch (See 09–15–18 SUNROOF SWITCH INSPECTION)</li> <li>• Inspect related harness</li> </ul>
			Other	0	
1D	Slide open	Sunroof switch	Sunroof is fully opening.	0	<ul style="list-style-type: none"> <li>• Inspect sunroof switch (See 09–15–18 SUNROOF SWITCH INSPECTION)</li> <li>• Inspect related harness</li> </ul>
			Other	B+	
1E	Tilt down	Sunroof switch	Sunroof is tilting down. (Not including position when fully closed)	B+	<ul style="list-style-type: none"> <li>• Inspect sunroof switch (See 09–15–18 SUNROOF SWITCH INSPECTION)</li> <li>• Inspect related harness</li> </ul>
			Other	0	
1F	Sunroof relay ground	GND	Under any condition: inspect for continuity to ground.	Yes	<ul style="list-style-type: none"> <li>• Inspect related harness</li> </ul>
2A	Slide close/ tilt up	Sunroof motor	Sunroof is opening/tilting down.	0	<ul style="list-style-type: none"> <li>• Inspect sunroof switch (See 09–15–18 SUNROOF SWITCH INSPECTION)</li> <li>• Inspect sunroof motor (See 09–15–12 SUNROOF MOTOR INSPECTION)</li> <li>• Inspect related harness</li> </ul>
			Sunroof is closing/tilting up.	B+	
			Other	0	
2B	Slide open/ tilt down	Sunroof motor	Sunroof is opening/tilting down.	B+	<ul style="list-style-type: none"> <li>• Inspect sunroof switch (See 09–15–18 SUNROOF SWITCH INSPECTION)</li> <li>• Inspect sunroof motor (See 09–15–12 SUNROOF MOTOR INSPECTION)</li> <li>• Inspect related harness</li> </ul>
			Sunroof is closing/tilting up.	0	
			Other	0	

# SUNROOF

## 5HB

1. Remove the headliner. (See 09–17–16 HEADLINER REMOVAL/INSTALLATION.)
2. Connect the sunroof switch connector.
3. Connect the negative battery cable.
4. Measure the voltage at the sunroof relay terminals as indicated below.
5. Disconnect the sunroof relay connector before inspecting for continuity at terminal H.
  - If not as specified, inspect the parts listed under “Action” and the related wiring harnesses.
  - If the parts and wiring harnesses are okay but the system still does not work properly, replace the sunroof relay.

### Terminal voltage list (Reference)

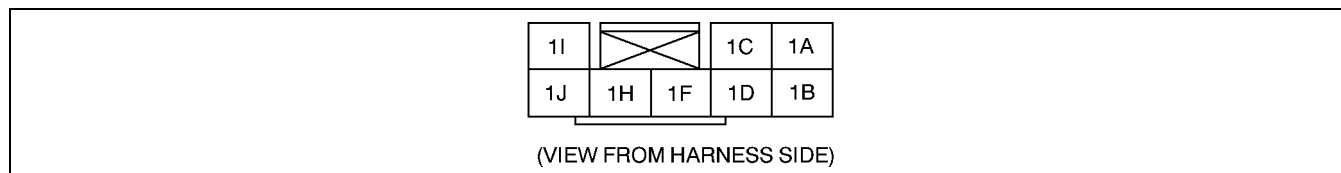

A3U0915W021

Terminal	Signal	Connected to	Test condition	Voltage (V)/ Continuity	Action
1A	Slide close/ tilt up	Sunroof motor	Sunroof is opening/tilting down.	0	<ul style="list-style-type: none"> <li>• Inspect sunroof switch (See 09–15–18 SUNROOF SWITCH INSPECTION)</li> <li>• Inspect sunroof motor (See 09–15–12 SUNROOF MOTOR INSPECTION)</li> <li>• Inspect related harness</li> </ul>
			Sunroof is closing/tilting up.	B+	
			Other	0	
1B	Slide close/ tilt up	Sunroof motor (Limit switch)	Sunroof is closing/tilting up.	0	<ul style="list-style-type: none"> <li>• Inspect sunroof switch (See 09–15–18 SUNROOF SWITCH INSPECTION)</li> <li>• Inspect sunroof motor (Limit switch) (See 09–15–12 SUNROOF MOTOR INSPECTION)</li> <li>• Inspect related harness</li> </ul>
			Other	B+	
1C	IG2	Sunroof switch	IG SW is at ON position.	B+	<ul style="list-style-type: none"> <li>• Inspect A/C 15 A fuse</li> <li>• Inspect sunroof switch (See 09–15–18 SUNROOF SWITCH INSPECTION)</li> <li>• Inspect related harness</li> </ul>
			Other	0	
1D	-	Not used	-	-	-
1F	IG2	Sunroof switch	IG SW is at ON position.	B+	<ul style="list-style-type: none"> <li>• Inspect A/C 15 A fuse</li> <li>• Inspect sunroof switch (See 09–15–18 SUNROOF SWITCH INSPECTION)</li> <li>• Inspect related harness</li> </ul>
			Other	0	
1H	Sunroof relay ground	GND	Under any condition: inspect for continuity to ground.	Yes	<ul style="list-style-type: none"> <li>• Inspect related harness</li> </ul>
1I	Slide open/ tilt down	Sunroof motor	Sunroof is opening/tilting down.	B+	<ul style="list-style-type: none"> <li>• Inspect sunroof switch (See 09–15–18 SUNROOF SWITCH INSPECTION)</li> <li>• Inspect sunroof motor (See 09–15–12 SUNROOF MOTOR INSPECTION)</li> <li>• Inspect related harness</li> </ul>
			Sunroof is closing/tilting up.	0	
			Other	0	
1J	Slide open/ tilt down	Sunroof motor (Limit switch)	Sunroof is opening/tilting down.	0	<ul style="list-style-type: none"> <li>• Inspect sunroof switch (See 09–15–18 SUNROOF SWITCH INSPECTION)</li> <li>• Inspect sunroof motor (Limit switch) (See 09–15–12 SUNROOF MOTOR INSPECTION)</li> <li>• Inspect related harness</li> </ul>
			Other	B+	

09–15

# SUNROOF

## SUNROOF SWITCH REMOVAL/INSTALLATION

A3U091566560W01

### Note

- The sunroof switch is together with the spot light.

- Disconnect the negative battery cable.
- Remove the spot light from the headliner. (See 09-18-21 MAP LIGHT REMOVAL/INSTALLATION.)
- Install in the reverse order of removal.

## SUNROOF SWITCH INSPECTION

A3U091566560W02

- Remove the sunroof switch. (See 09-18-21 MAP LIGHT REMOVAL/INSTALLATION.)
- Inspect for continuity between the sunroof switch terminals using an ohmmeter.
  - If not as specified, replace the sunroof switch.

○—○ : Continuity

Switch position	Terminal						
	1B	1C	1D	1E	1F	1A	2A
Slide open			○	—	○	○	○
Slide close		○	—	—	○	○	○
Tilt up	○	—	—	—	○	○	○
Tilt down				○	○	○	○
Off						○	○

X3U915WAU

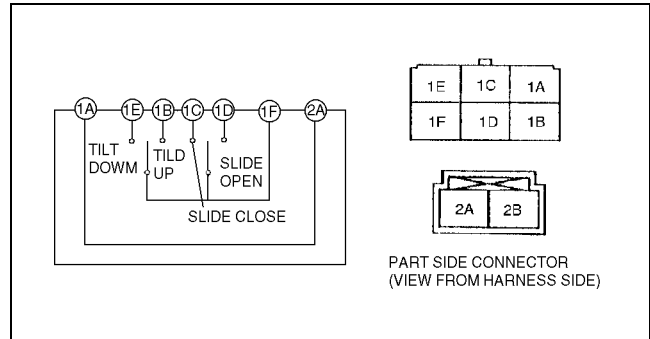

Z3U0915W001

# 09-16 EXTERIOR TRIM

**COWL GRILLE**  
 REMOVAL/INSTALLATION ..... 09-16-1

**EXTRACTOR CHAMBER**  
 REMOVAL/INSTALLATION ..... 09-16-1  
 4SD ..... 09-16-1  
 5HB ..... 09-16-2

**FRONT FLAP**  
 REMOVAL/INSTALLATION ..... 09-16-2

**REAR FLAP**  
 REMOVAL/INSTALLATION ..... 09-16-2

**RADIATOR**  
 GRILLE REMOVAL/INSTALLATION .. 09-16-2

**REAR FINISHER**  
 REMOVAL/INSTALLATION ..... 09-16-3

**LIFTGATE GARNISH**  
 REMOVAL/INSTALLATION ..... 09-16-3

**SIDE PROTECTOR REMOVAL** ..... 09-16-3

**SIDE PROTECTOR INSTALLATION** ... 09-16-4

**SIDE PROTECTOR INSTALLATION** ... 09-16-4

**SIDE STEP MOLDING**  
 REMOVAL/INSTALLATION ..... 09-16-4

**ROOF RACK**  
 REMOVAL/INSTALLATION ..... 09-16-4

**ROOF RACK**  
 DISASSEMBLY/ASSEMBLY ..... 09-16-5

**ROOF CARRIER**  
 REMOVAL/INSTALLATION ..... 09-16-5  
 Front ..... 09-16-5  
 Rear ..... 09-16-6

**FRONT BELTLINE MOLDING**  
 REMOVAL/INSTALLATION ..... 09-16-7

**REAR BELTLINE MOLDING**  
 REMOVAL/INSTALLATION ..... 09-16-7

**REAR WINDOW GLASS**  
 MOLDING REMOVAL ..... 09-16-7

**EAR WINDOW GLASS**  
 MOLDING INSTALLATION ..... 09-16-7

**WINDSHIELD MOLDING REMOVAL**... 09-16-8

**WINDSHIELD MOLDING**  
 INSTALLATION ..... 09-16-8

**ROOF MOLDING**  
 REMOVAL/INSTALLATION ..... 09-16-8

**REAR SPOILER**  
 REMOVAL/INSTALLATION ..... 09-16-8  
 4SD ..... 09-16-8  
 5HB ..... 09-16-9

## COWL GRILLE REMOVAL/INSTALLATION

A3U091650790W01

1. Remove the windshield wiper arm and blade. (See 09-19-5 WINDSHIELD WIPER ARM AND BLADE REMOVAL/INSTALLATION.)
2. Remove the weatherstrip.
3. Disengage the clips of the cowl grille using a fastener remover, then remove the cowl grille.
4. Install in the reverse order of removal.

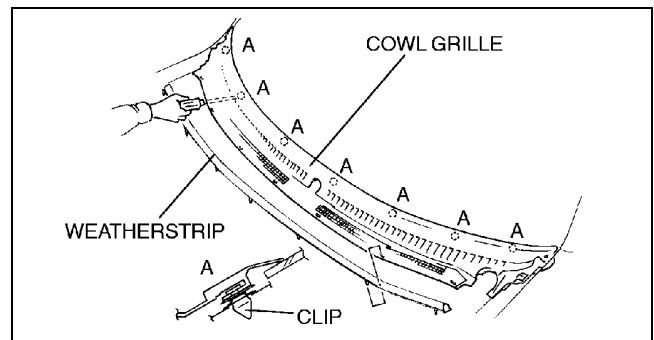

X3U916WA0

## EXTRACTOR CHAMBER REMOVAL/INSTALLATION

A3U091651920W01

### 4SD

1. Remove the rear bumper.
2. Remove the passenger-side trunk side trim.
3. Remove the screw.
4. Squeeze the clips with your fingers and remove the extractor chamber from the vehicle side.
5. Install in the reverse order of removal.

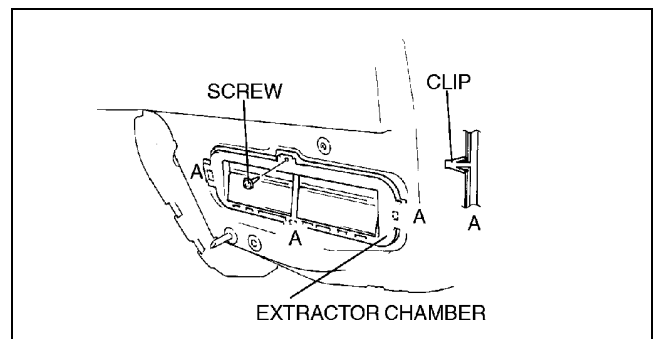

X3U916WA1

## EXTERIOR TRIM

### 5HB

1. Remove the rear bumper.
2. Squeeze the clips with your fingers and remove the extractor chamber from the vehicle side.
3. Install in the reverse order of removal.

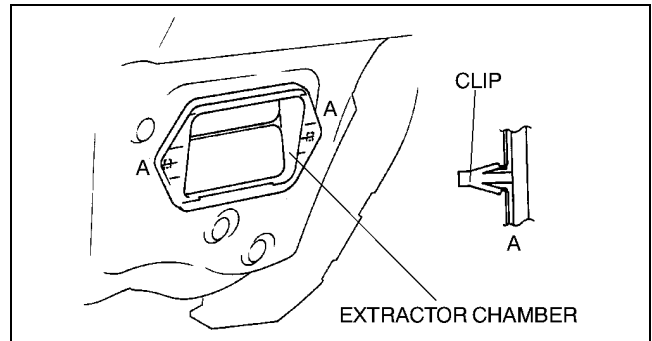

A3U0916W001

### FRONT FLAP REMOVAL/INSTALLATION

1. Remove the bolts and fasteners.
2. Remove the front flap.
3. Install in the reverse order of removal.

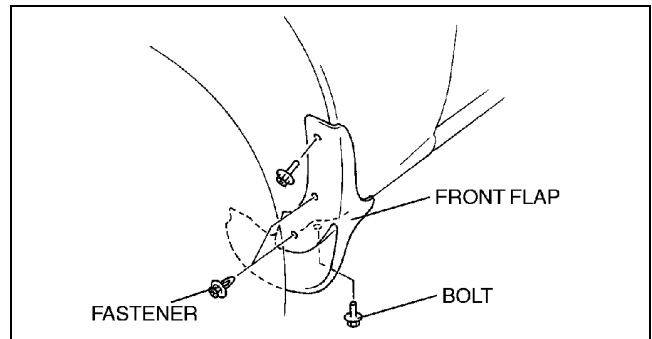

A3U091651840W01

X3U916WA2

### REAR FLAP REMOVAL/INSTALLATION

1. Remove the bolts.
2. Remove the rear flap.
3. Install in the reverse order of removal.

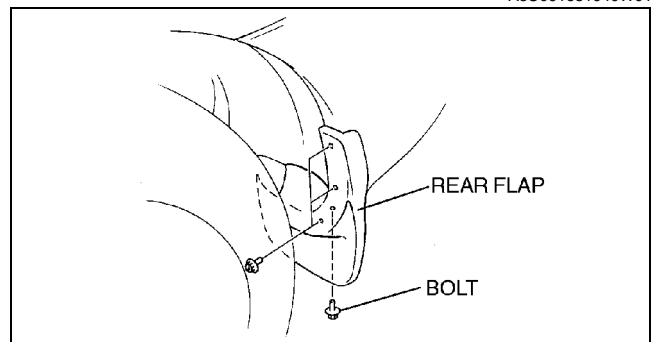

A3U091651940W01

X3U916WA3

### RADIATOR GRILLE REMOVAL/INSTALLATION

1. Remove the front bumper. (See 09-10-5 FRONT BUMPER REMOVAL/INSTALLATION.)
2. Pull the radiator grille forward to disengage clips A and tabs B from the front bumper.
3. Install in the reverse order of removal.

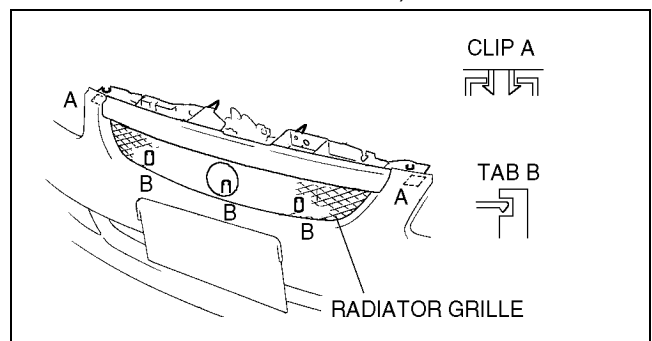

A3U091650710W01

Y3E7728W001

## EXTERIOR TRIM

### REAR FINISHER REMOVAL/INSTALLATION

A3U091650810W01

1. Remove the nuts.
2. Pull the rear finisher toward you, then disengage clip A from the body.
3. Install in the reverse order of removal.

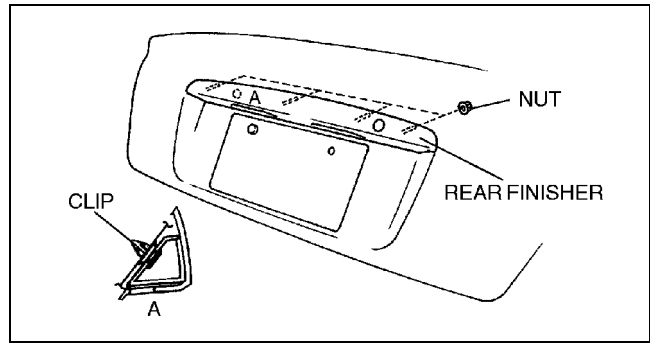

X3U916WA5

### LIFTGATE GARNISH REMOVAL/INSTALLATION

A3U091650810W02

1. Remove the liftgate key cylinder. (See 09–11–7 LIFTGATE REMOVAL/INSTALLATION.)
2. Remove the bolts.

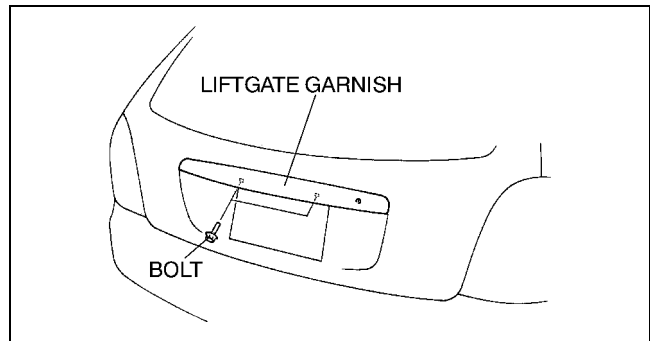

A3U0916W004

3. Disengage clip A using pliers.
4. Pull the liftgate garnish downward, then remove it.
5. Install in the reverse order of removal.

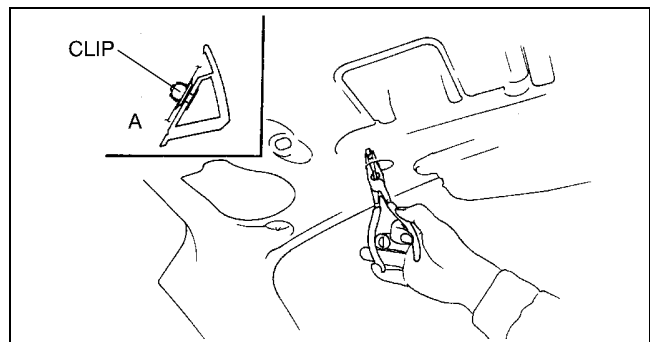

A3U0916W005

### SIDE PROTECTOR REMOVAL

A3U091650680W01

1. Pry the side protector end **20—30 mm {0.8—1.1 in}** using a flathead screwdriver or a razor.

#### Warning

- Using a razor with bare hands can cause injury. Always wear gloves when using a razor.

2. Pull the side protector toward you, then remove it.

#### Note

- The side protector is installed with double-sided adhesive tape. If the side protector is difficult to remove, soften the double-sided adhesive tape using a hot air blower.

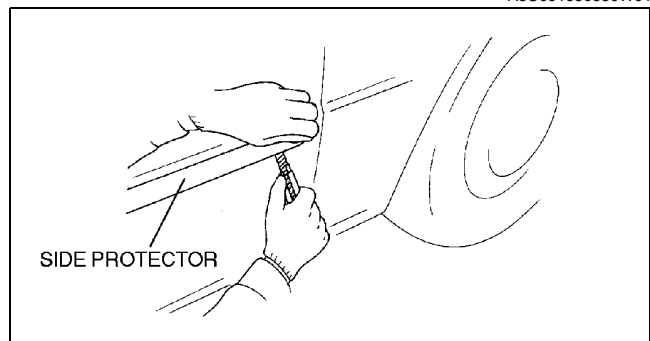

Y3U916WA1



# EXTERIOR TRIM

## SIDE PROTECTOR INSTALLATION

A3U091650680W02

1. Remove the adhesive remaining on the side protector (if it will be reused) and the body using a razor.
2. Remove any grease or dirt from the adhesion surface of the side protector (if it will be reused) and the body.
3. Attach double-sided adhesive tape to the side protector as shown (if it will be reused).

### Clearance

- a: 25.0 mm {0.98 in}
- b: 7.0 mm {0.28 in}
- c: 1.0—3.0 mm {0.04—0.11 in}
- d: 9.0 mm {0.35 in}

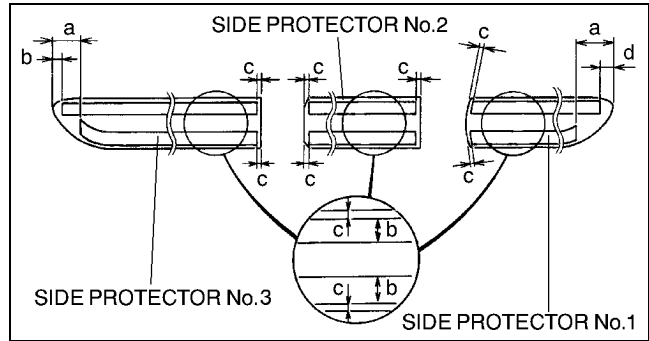

A3U0916W002

4. Peel off the backing from the double-sided adhesive tape and attach the side protector onto the body as shown.

### Clearance

- a: 0.66—3.66 mm {0.03—0.14 in}
- b: 7.74 mm {0.30 in}
- c: 4.0—7.0 mm {0.16—0.27 in}
- d: 0.5—3.5 mm {0.02—0.13 in}
- e: 3.0—6.0 mm {0.12—0.23 in}

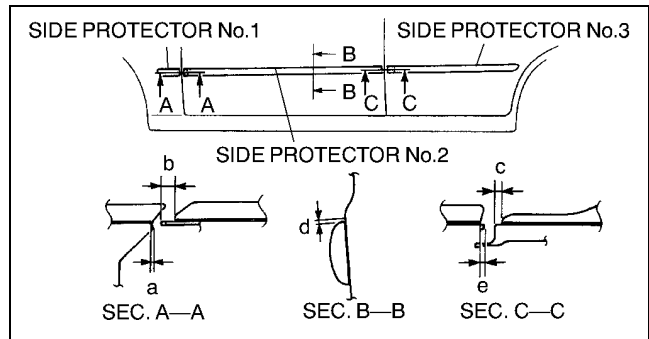

A3U0916W003

## SIDE STEP MOLDING REMOVAL/INSTALLATION

A3U091651100W01

1. Remove the fasteners and clips B.
2. Disengage clips A from the vehicle front to remove the side step molding.
3. Install in the reverse order of removal.

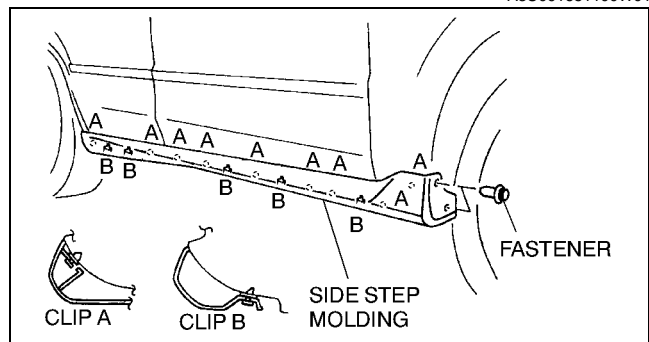

A3U0916W008

## ROOF RACK REMOVAL/INSTALLATION

A3U091651720W01

1. Remove the headliner.
2. Remove the nuts.
3. Pull the roof rack upward, then remove the roof rack from the roof.
4. Install in the reverse order of removal.

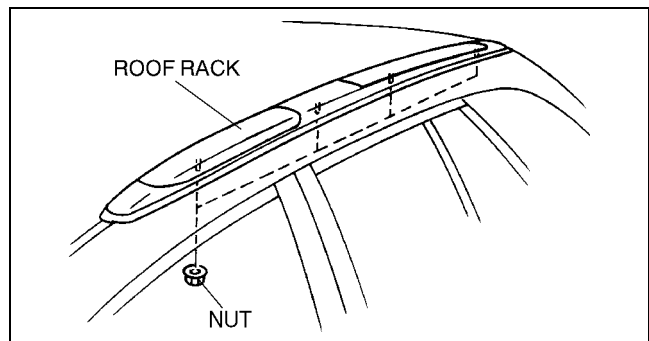

Z4F7728W001

## EXTERIOR TRIM

### ROOF RACK DISASSEMBLY/ASSEMBLY

A3U091651720W02

1. Disassemble in the order indicated in the table.

1	Front cap
2	Rear cap
3	Screw
4	Front stay
5	Rear stay

2. Assemble in the reverse order of disassembly.

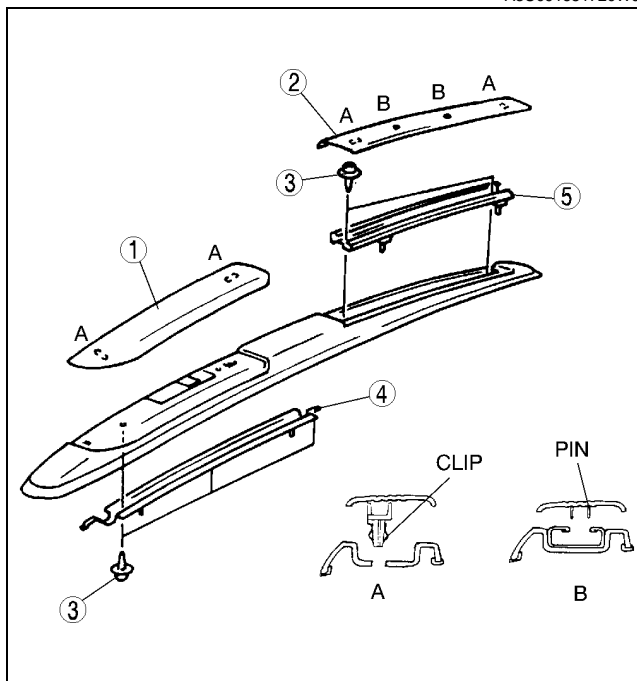

Z4F7728W002

### ROOF CARRIER REMOVAL/INSTALLATION

A3U091651720W03

#### Caution

- When installing the front carrier bar to the vehicle, use two or more people to do the work and do not scratch the vehicle body.

#### Front

1. Remove in the order indicated in the table.

1	Screw
2	Cover A
3	Cover B
4	Bolt
5	Front carrier bar (See 09-16-6 Front Carrier Bar Installation Note.)

2. Install in the reverse order of removal.

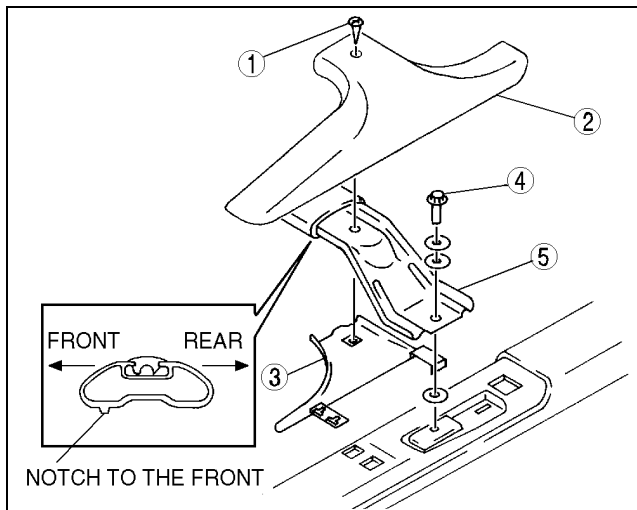

A3U0916W011

## EXTERIOR TRIM

### Front Carrier Bar Installation Note

1. Loosen the bolt under the front carrier bar, and adjust the front carrier bar position.

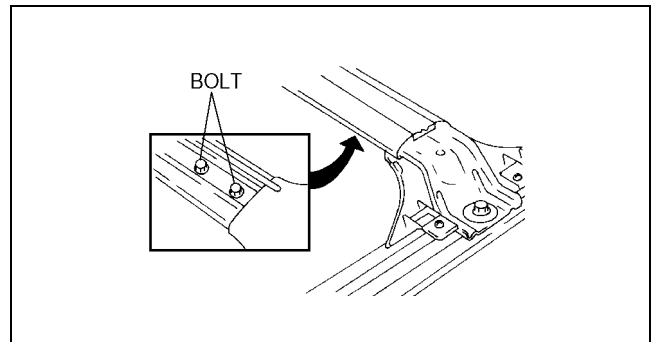

A3U0916W014

### Rear

1. Remove in the order indicated in the table.

1	Front cover
2	Screw A
3	Cover A
4	Bolt
5	Rear carrier bar (See 09-16-6 Rear Carrier Bar Removal Note.) (See 09-16-7 Rear Carrier Bar Installation Note.)
6	Spacer
7	Stay
8	Screw B
9	Cover B
10	Rear cover

2. Install in the reverse order of removal.

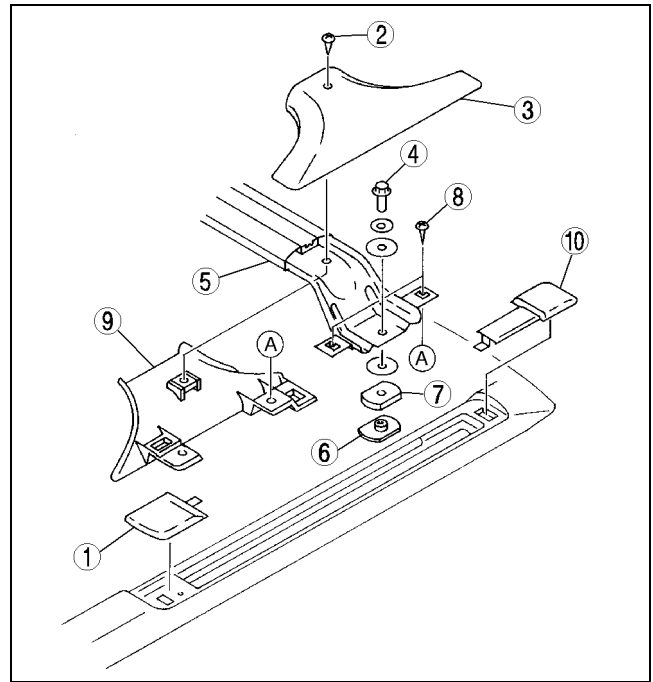

A3U0916W013

### Rear Carrier Bar Removal Note

1. Loosen the bolt, slide the rear carrier bar and stay, and remove them from the rail.

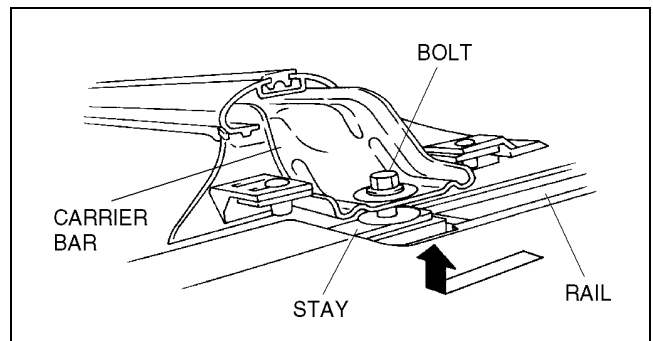

A3U0916W010

## EXTERIOR TRIM

### Rear Carrier Bar Installation Note

1. Loosen the bolt under the rear carrier bar, and adjust the rear carrier bar position.
2. When the rear carrier bar is in the final position, align the square hole line for cover B with the rear cover line.

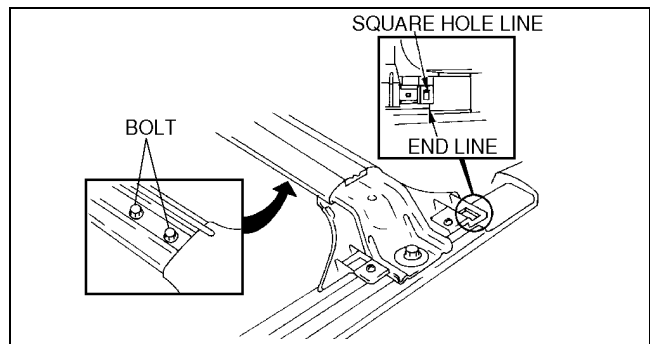

A3U0916W012

### FRONT BELTLINE MOLDING REMOVAL/INSTALLATION

1. Open the front door glass fully.
2. Remove the screw.
3. Pull the front beltline molding up, then remove it.
4. Install in the reverse order of removal.

A3U091650640W01

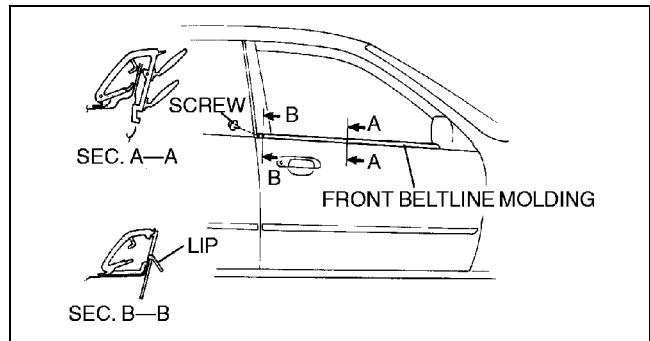

X3U916WA9

### REAR BELTLINE MOLDING REMOVAL/INSTALLATION

1. Remove the rear door glass. (See 09-11-5 REAR DOOR DISASSEMBLY/ASSEMBLY.)
2. Remove the screw.
3. Pull the rear beltline molding up, then disengage clip A.
4. Install in the reverse order of removal.

A3U091650660W01

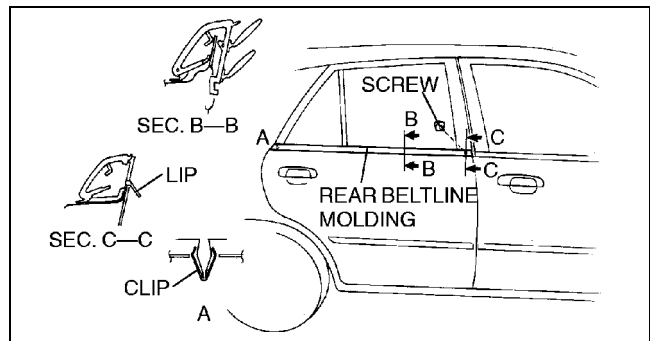

X3U916WAA

### REAR WINDOW GLASS MOLDING REMOVAL

A3U091650690W01

#### Note

- Rear window glass molding is a replacement part.

1. Remove the rear window glass. (See 09-12-11 REAR WINDOW GLASS REMOVAL.)
2. Remove the rear window glass molding from the rear window glass.

### REAR WINDOW GLASS MOLDING INSTALLATION

A3U091650690W02

#### Note

- Rear window glass molding is a replacement part.

1. Install the rear window glass molding to the rear window glass. (See 09-12-14 REAR WINDOW GLASS INSTALLATION.)

# EXTERIOR TRIM

## WINDSHIELD MOLDING REMOVAL

A3U091650600W01

### Note

- Windshield molding is a replacement part.

1. Remove the windshield. (See 09–12–19 WINDSHIELD REMOVAL.)
2. Remove the windshield molding from the windshield.

## WINDSHIELD MOLDING INSTALLATION

A3U091650600W02

### Note

- Windshield molding is a replacement part.

1. Install the windshield molding to the windshield. (See 09–12–21 WINDSHIELD INSTALLATION.)

## ROOF MOLDING REMOVAL/INSTALLATION

A3U091650620W01

1. Pull the front edge and rear edge of the roof molding up (1).
2. Slide the roof molding rearward, then remove it (2).
3. Install in the reverse order of removal.

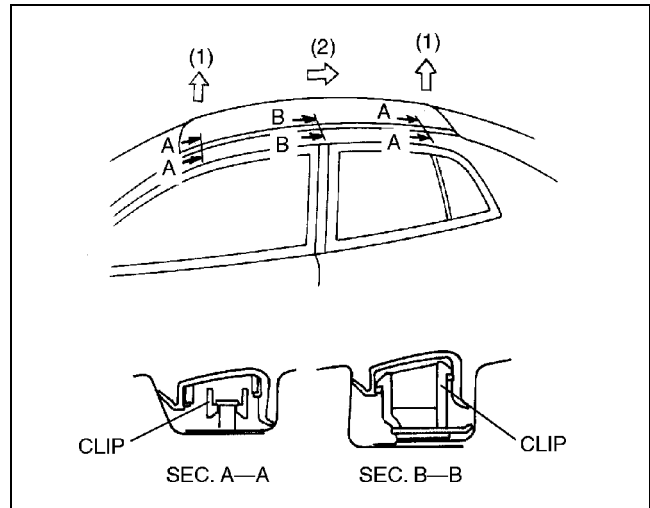

X3U916WAB

## REAR SPOILER REMOVAL/INSTALLATION

A3U091651950W01

### 4SD

1. Disconnect the negative battery cable.
2. Disconnect the high-mount brake light connector.
3. Remove the bolts.
4. Pull the rear spoiler upward, then remove it.
5. Install in the reverse order of removal.

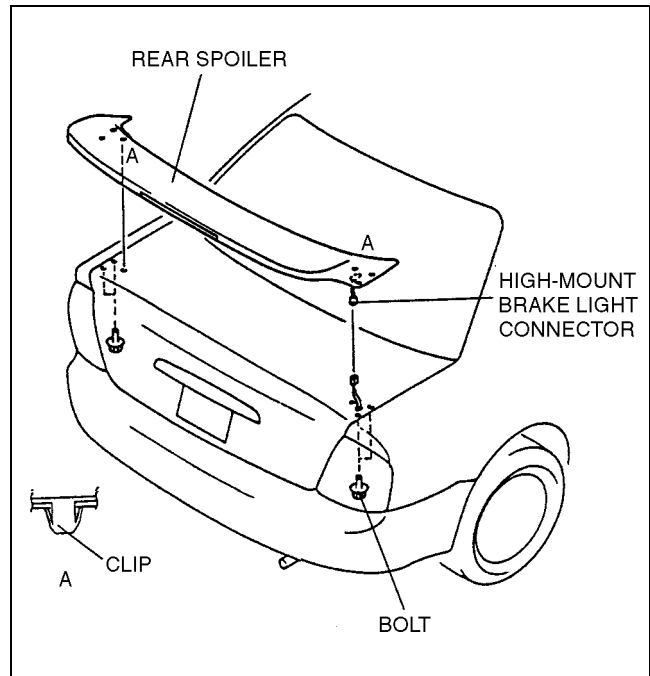

Y3U916WA0

## EXTERIOR TRIM

### 5HB

1. Disconnect the negative battery cable.
2. Remove the hole cover A using a tape-wrapped screwdriver.
3. Remove the fasteners, then remove hole cover B.
4. Pull out the high-mount brake light connector, then disconnect it.

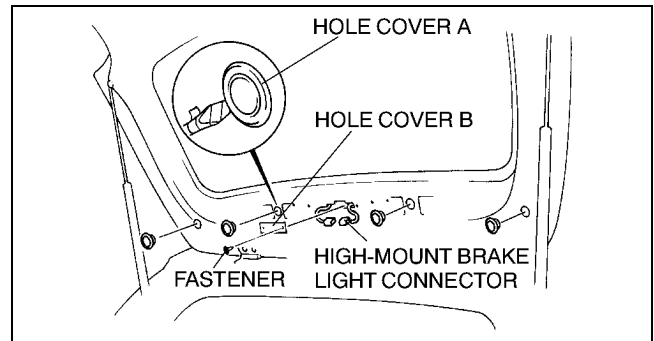

A3U0916W006

5. Remove the bolts and nuts.
6. Pull the rear spoiler upward, then disengage clips A from the body.
7. Install in the reverse order of removal.

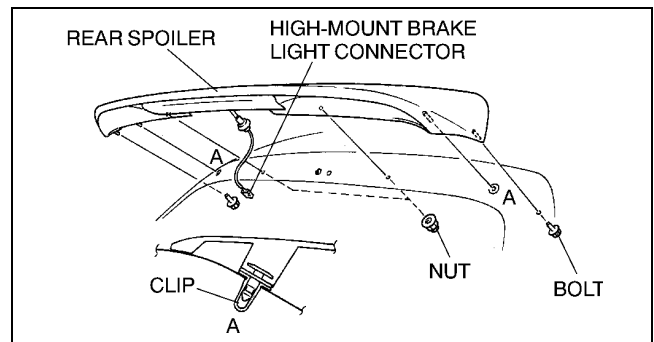

A3U0916W007

09-16

**09-17 INTERIOR TRIM**

<b>DASHBOARD</b>		<b>B-PILLAR LOWER TRIM</b>	
REMOVAL/INSTALLATION . . . . .	09-17-1	INSTALLATION . . . . .	09-17-11
<b>DASHBOARD</b>		<b>B-PILLAR UPPER TRIM</b>	
DISASSEMBLY/ASSEMBLY . . . . .	09-17-3	REMOVAL/INSTALLATION . . . . .	09-17-11
<b>VENTILATOR GRILLE</b>		<b>C-PILLAR TRIM</b>	
REMOVAL/INSTALLATION . . . . .	09-17-3	REMOVAL/INSTALLATION . . . . .	09-17-11
Center Side . . . . .	09-17-3	4SD . . . . .	09-17-11
Driver's side . . . . .	09-17-4	5HB . . . . .	09-17-12
Passenger's side . . . . .	09-17-4	<b>REAR PACKAGE TRIM</b>	
<b>CENTER PANEL</b>		REMOVAL/INSTALLATION . . . . .	09-17-12
REMOVAL/INSTALLATION . . . . .	09-17-4	4SD . . . . .	09-17-12
<b>COLUMN COVER</b>		5HB . . . . .	09-17-12
REMOVAL/INSTALLATION . . . . .	09-17-5	<b>FRONT SCUFF PLATE</b>	
<b>CONSOLE ADJUSTMENT</b> . . . . .	09-17-5	REMOVAL/INSTALLATION . . . . .	09-17-13
<b>CONSOLE REMOVAL/INSTALLATION</b> .	09-17-5	<b>REAR SCUFF PLATE</b>	
Boot Panel Removal Note . . . . .	09-17-6	REMOVAL/INSTALLATION . . . . .	09-17-13
Console Cover Removal Note . . . . .	09-17-6	<b>FRONT SIDE TRIM</b>	
<b>CONSOLE DISASSEMBLY/ASSEMBLY</b>	09-17-6	REMOVAL/INSTALLATION . . . . .	09-17-13
<b>GLOVE COMPARTMENT</b>		<b>TIRE HOUSE TRIM</b>	
REMOVAL/INSTALLATION . . . . .	09-17-7	REMOVAL/INSTALLATION . . . . .	09-17-13
<b>LOWER PANEL</b>		4SD . . . . .	09-17-13
REMOVAL/INSTALLATION . . . . .	09-17-7	5HB . . . . .	09-17-14
Driver's side . . . . .	09-17-7	<b>TRUNK END TRIM</b>	
Passenger's side . . . . .	09-17-7	REMOVAL/INSTALLATION . . . . .	09-17-14
<b>METER HOOD</b>		<b>TRUNK SIDE TRIM</b>	
REMOVAL/INSTALLATION . . . . .	09-17-8	REMOVAL/INSTALLATION . . . . .	09-17-15
<b>SIDE PANEL</b>		4SD . . . . .	09-17-15
REMOVAL/INSTALLATION . . . . .	09-17-8	5HB . . . . .	09-17-15
<b>SIDE WALL REMOVAL/INSTALLATION</b>	09-17-8	<b>TRUNK SIDE UPPER TRIM</b>	
<b>FRONT DOOR TRIM</b>		REMOVAL/INSTALLATION . . . . .	09-17-15
REMOVAL/INSTALLATION . . . . .	09-17-9	<b>LIFTGATE TRIM</b>	
<b>REAR DOOR TRIM</b>		REMOVAL/INSTALLATION . . . . .	09-17-16
REMOVAL/INSTALLATION . . . . .	09-17-9	<b>HEADLINER</b>	
<b>A-PILLAR TRIM</b>		REMOVAL/INSTALLATION . . . . .	09-17-16
REMOVAL/INSTALLATION . . . . .	09-17-10	<b>FLOOR COVERING</b>	
<b>B-PILLAR LOWER TRIM REMOVAL</b> . . .	09-17-10	REMOVAL/INSTALLATION . . . . .	09-17-17

09-17

**DASHBOARD REMOVAL/INSTALLATION**

A3U091755100W01

1. Remove the passenger-side air bag module if equipped. (See 08-10-6 PASSENGER-SIDE AIR BAG MODULE REMOVAL/INSTALLATION.)
2. Remove the combination switch. (See 09-18-12 COMBINATION SWITCH REMOVAL/INSTALLATION.)
3. Remove the installation bolts then shift the assembled steering shaft in the dashboard. (See 06-12-6 STEERING WHEEL AND COLUMN REMOVAL/INSTALLATION.)
4. Remove the instrument cluster. (See 09-22-3 INSTRUMENT CLUSTER REMOVAL/INSTALLATION.)
5. Remove the console. (See 09-17-5 CONSOLE REMOVAL/INSTALLATION.)
6. Remove the glove compartment.
7. Remove the lower panel.
8. Remove the hood release cable installation nut.
9. Remove the side wall.
10. Remove the A-pillar trim. (See 09-17-10 A-PILLAR TRIM REMOVAL/INSTALLATION.)
11. Remove the side panel.

## INTERIOR TRIM

12. Disconnect the antenna plug.
13. For vehicles equipped with the semi-logic type climate control unit, disconnect the wires for the heater unit. (See 07-40-9 CLIMATE CONTROL UNIT REMOVAL.) (See 07-40-10 CLIMATE CONTROL UNIT INSTALLATION.)

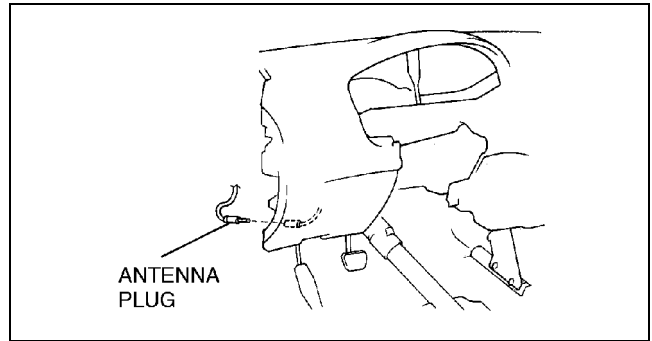

14. Disconnect the connectors.

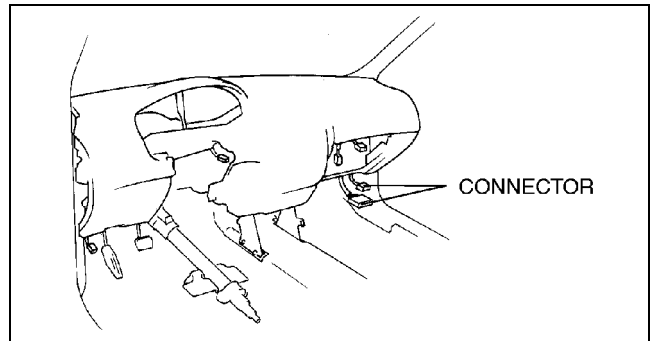

15. Remove the bolts.
16. Remove the dashboard from the vehicle.

### Warning

- Removing the dashboard without supporting it can be dangerous. The dashboard may fall and injure you. Always perform these procedures together with at least another person.

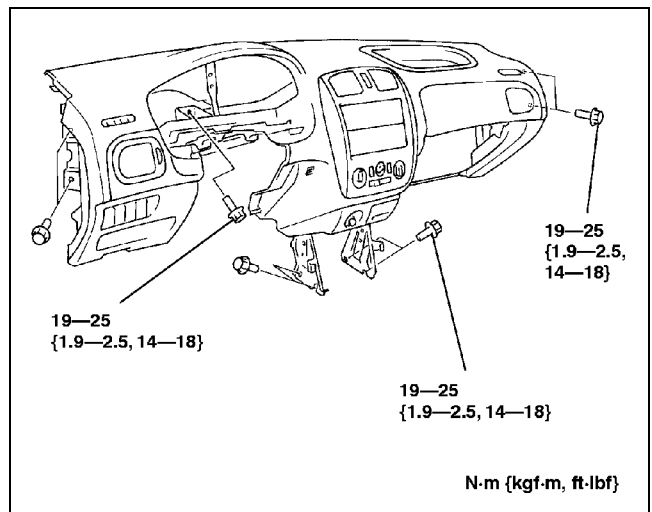

- (1) Incline the dashboard slowly forward.
  - (2) Lift up the dashboard while it is inclined forward.
  - (3) Remove the dashboard from the vehicle through the passenger-side front door.
17. Install in the reverse order of removal.

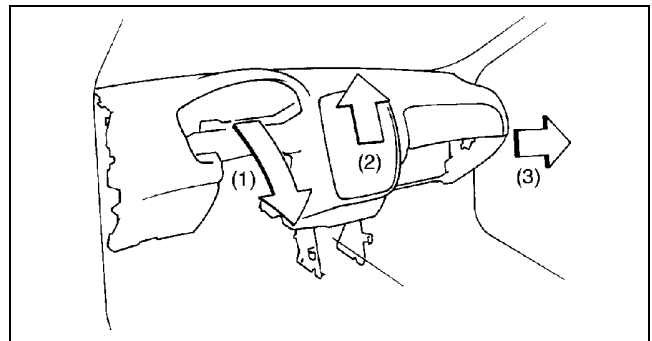



# INTERIOR TRIM

## DASHBOARD DISASSEMBLY/ASSEMBLY

A3U091755100W02

1. Disassemble in the order indicated in the table.
2. Assemble in the reverse order of disassembly.

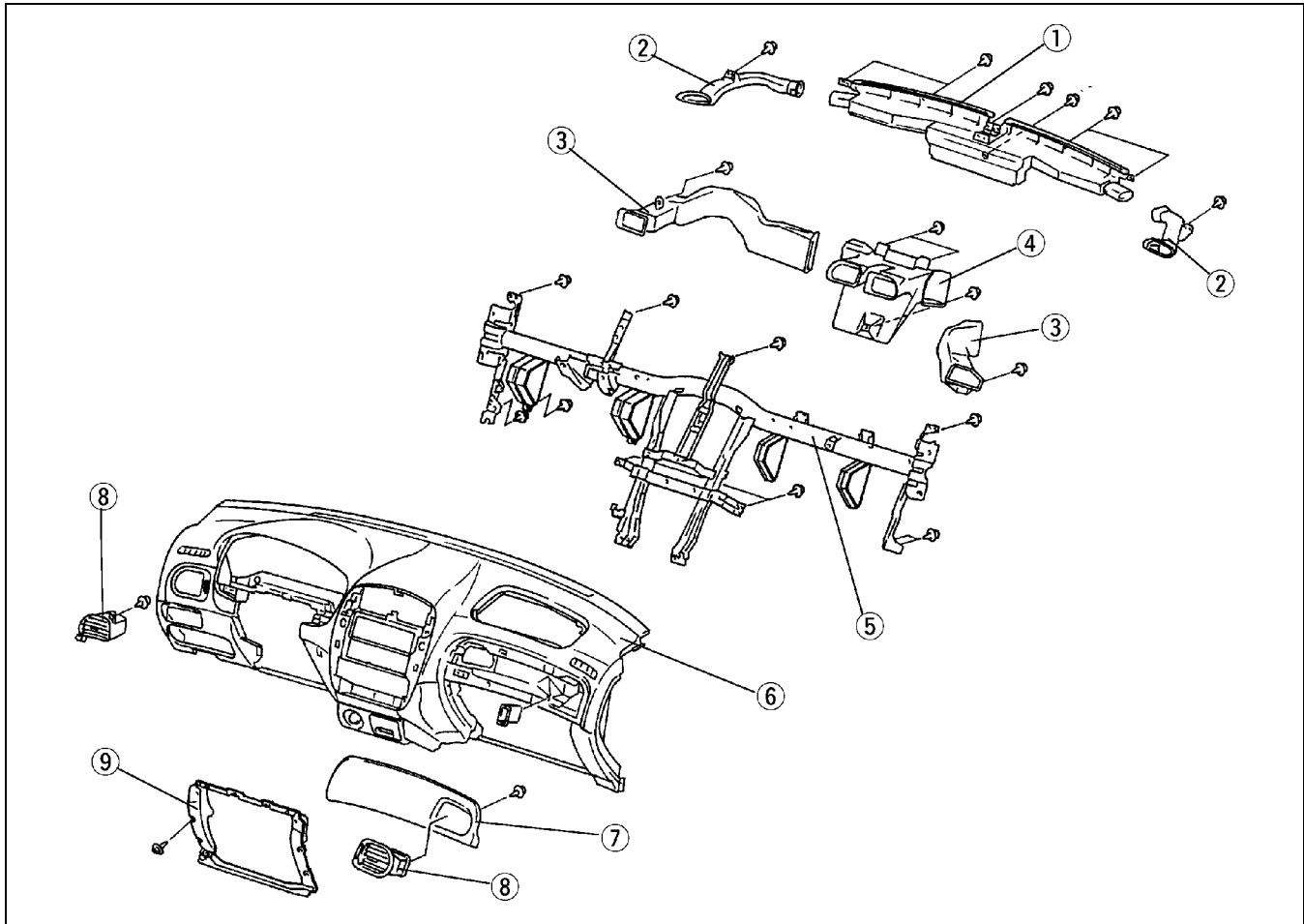

X3U917WA4

1	Defroster nozzle
2	Side demister duct
3	Duct
4	Center duct
5	Dashboard member

6	Crush pad
7	Pad
8	Ventilator grille
9	Passenger-side lower panel

## VENTILATOR GRILLE REMOVAL/INSTALLATION

A3U091764730W01

### Center Side

1. Remove the center panel. (See 09-17-4 CENTER PANEL REMOVAL/INSTALLATION.)
2. Remove the screws from behind the center panel.
3. Install in the reverse order of removal.

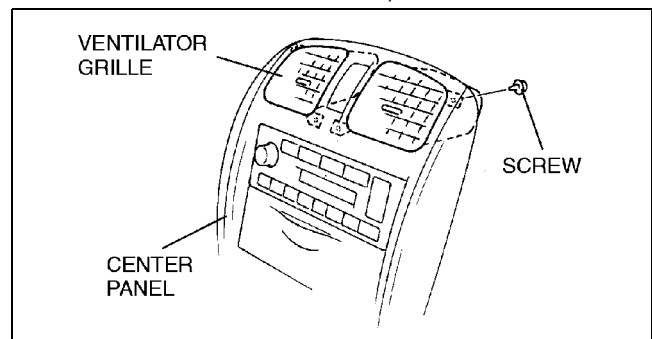

X3U917WA5

## INTERIOR TRIM

### Driver's side

1. Remove the dashboard. (See 09-17-1 DASHBOARD REMOVAL/INSTALLATION.)
2. Remove the screws from behind the dashboard.
3. Install in the reverse order of removal.

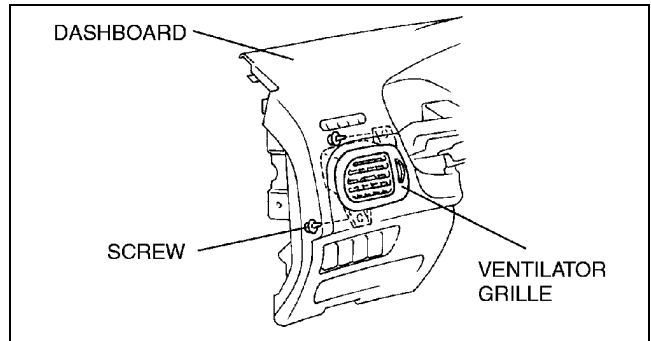

X3U917WA6

### Passenger's side

1. Disengage clips A and B using a fastener remover as shown in the figure.
2. Install in the reverse order of removal.

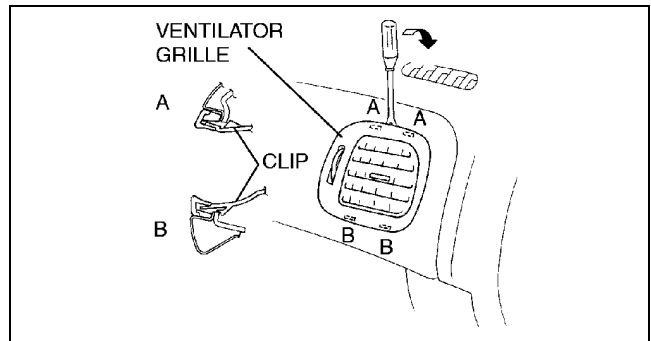

X3U917WA7

### CENTER PANEL REMOVAL/INSTALLATION

A3U091755210W01

1. Disconnect the negative battery cable.
2. Remove the glove compartment.
3. For vehicles equipped with the semi-logic type climate control unit, disconnect the wires for the heater unit. (See 07-40-9 CLIMATE CONTROL UNIT REMOVAL.) (See 07-40-10 CLIMATE CONTROL UNIT INSTALLATION.)
4. Push out clip A from behind the dashboard.

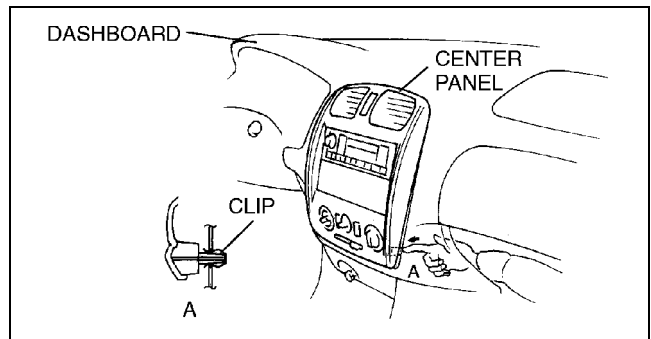

X3U917WA8

5. Pull the center panel, then remove clips B and pins C from the dashboard.
6. Disconnect the hazard warning switch connector and climate control unit connector.
7. Install in the reverse order of removal.

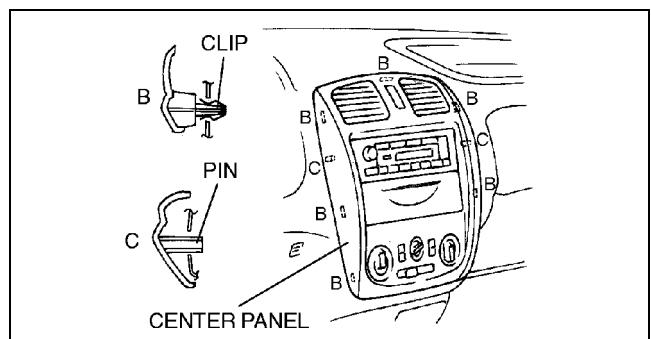

X3U917WA9

# INTERIOR TRIM

## COLUMN COVER REMOVAL/INSTALLATION

A3U091760200W01

1. Remove the screws, then remove the column cover.
2. Install in the reverse order of removal.

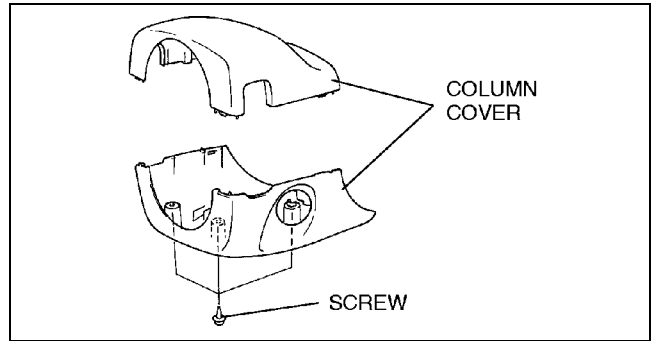

X3U917WAA

## CONSOLE ADJUSTMENT

A3U091764310W01

### Caution

- Take care to install the console and the center panel so that there is no interference which may cause noise.

1. Loosen screws A.
2. Slide the console indicated by the arrow and measure the gap between the console and the dashboard.

### Clearance

a: 0.2—1.8 mm {0.0008—0.07 in}

3. Tighten screws A.

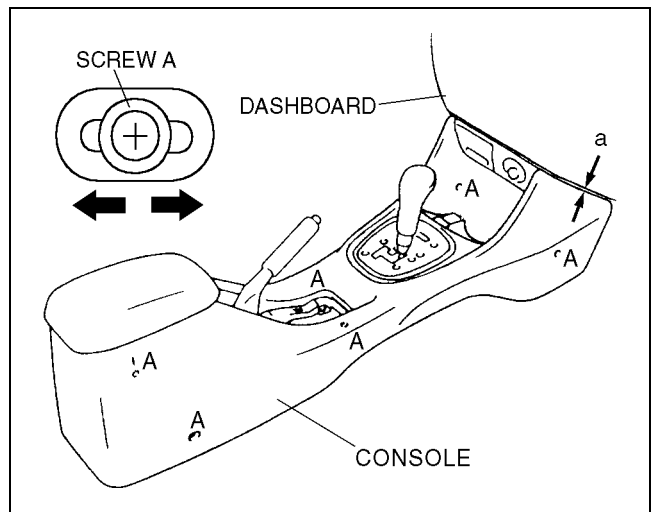

Z3U0917W006

09-17

## CONSOLE REMOVAL/INSTALLATION

A3U091764310W02

1. For MTX vehicle, remove the shift lever knob.
2. Remove in the order indicated in the table.

1	Boot panel (See 09-17-6 Boot Panel Removal Note.)
2	Console cover (See 09-17-6 Console Cover Removal Note.)
3	Screw
4	Console

3. Install in the reverse order of removal.

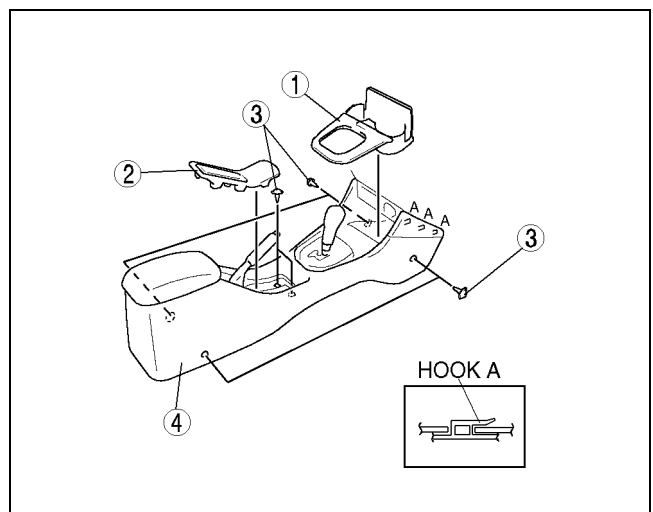

Z3U0917W007

# INTERIOR TRIM

## Boot Panel Removal Note

1. Pull the boot panel upward, then disengage clips A and B from the console.

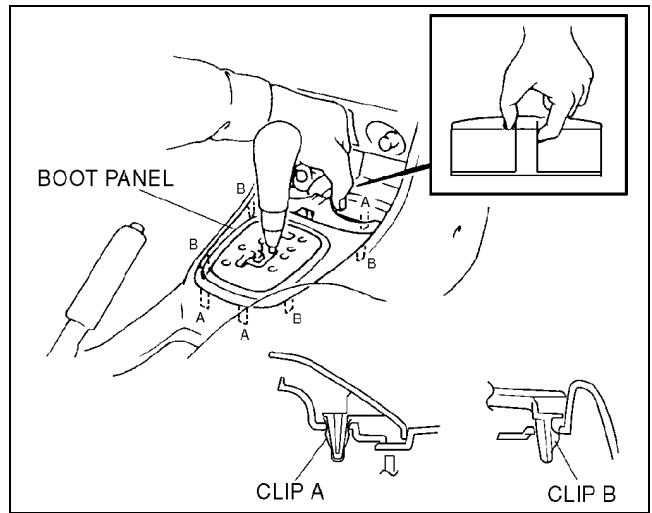

Y3E7742W301

## Console Cover Removal Note

1. Disengage clip A using a tape-wrapped flathead screwdriver.
2. Pull the console cover upward, then disengage hook B from the console.

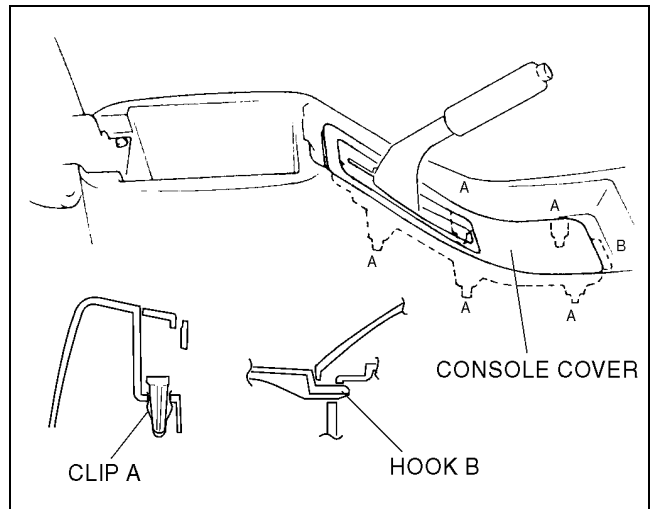

Y3E7742W302

## CONSOLE DISASSEMBLY/ASSEMBLY

1. Disassemble in the order indicated in the table.

1	Screw A
2	Side wall
3	Cover
4	Screw B (MTX)
5	Screw C (MTX)
6	Boot (MTX)
7	Screw D
8	Screw E
9	Console lid hinge
10	Console lid inner
11	Screw F
12	Console lid lock
13	Console lid outer
14	Ashtray
15	Screw G
16	Bracket

A3U091764310W03

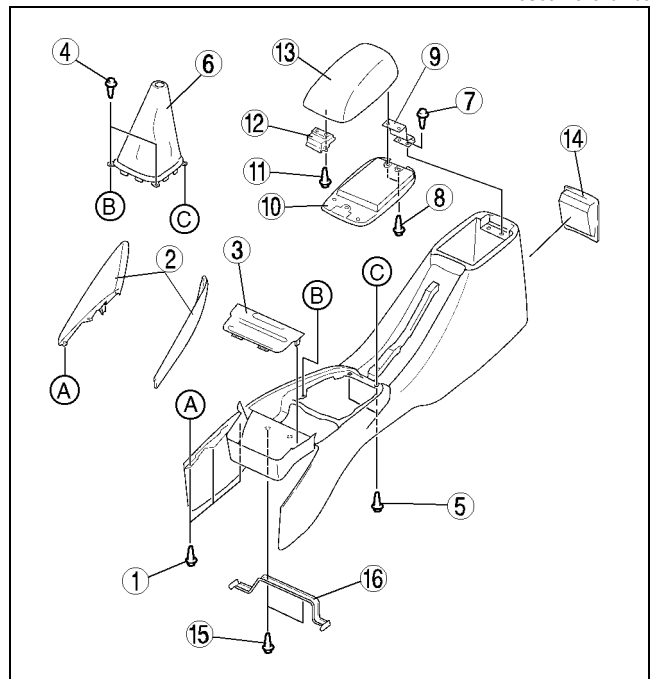

Y3E7742W305

2. Assemble in the reverse order of disassembly.

# INTERIOR TRIM

## GLOVE COMPARTMENT REMOVAL/INSTALLATION

A3U091764030W01

1. Bend the stoppers inward, then remove them.

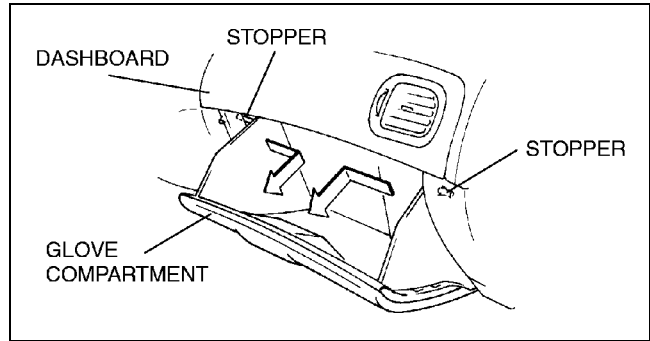

X3U917WAG

2. Pull the glove compartment toward you while pushing it downward (1), then remove clip A.
3. Slide the glove compartment toward driver's side door (2).
4. Install in the reverse order of removal.

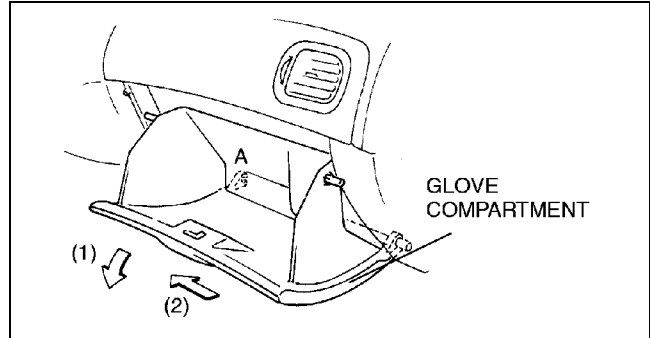

X3U917WAH

## LOWER PANEL REMOVAL/INSTALLATION

A3U091764280W01

### Driver's side

1. Pull the upper side of the lower panel downward, then disengage clips A and pins B from the dashboard.
2. Pull the lower panel toward you, then disengage hooks C from the dashboard.
3. Install in the reverse order of removal.

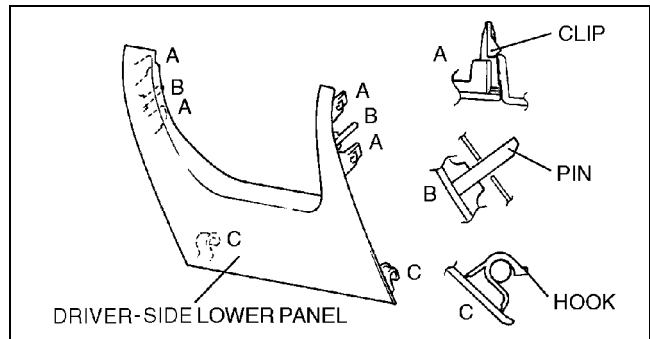

Z3U0917W003

### Passenger's side

1. Remove the glove compartment.
2. Remove the screws.
3. Install in the reverse order of removal.

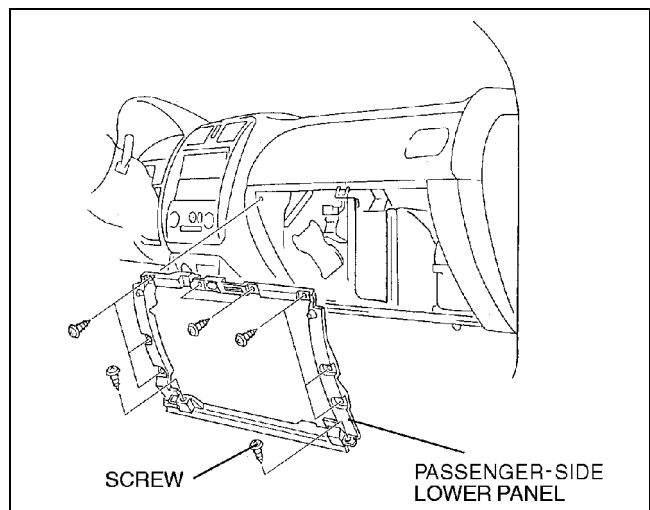

Z3U0917W004

# INTERIOR TRIM

## METER HOOD REMOVAL/INSTALLATION

A3U091755420W01

1. Remove the screws.
2. Pull the meter hood toward you, then remove clips A and pins B from the dashboard.
3. Install in the reverse order of removal.

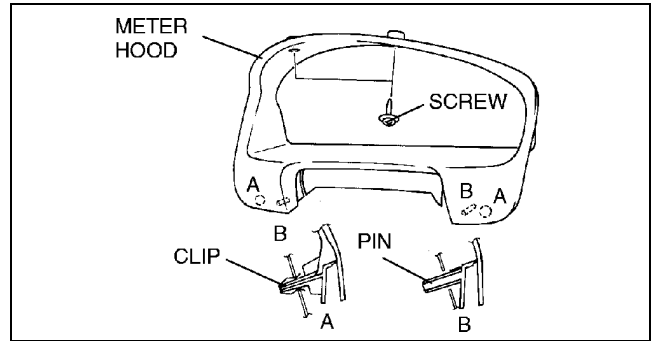

X3U917WAL

## SIDE PANEL REMOVAL/INSTALLATION

A3U091764960W01

1. Remove clips A using a tape-wrapped flathead screwdriver.
2. Install in the reverse order of removal.

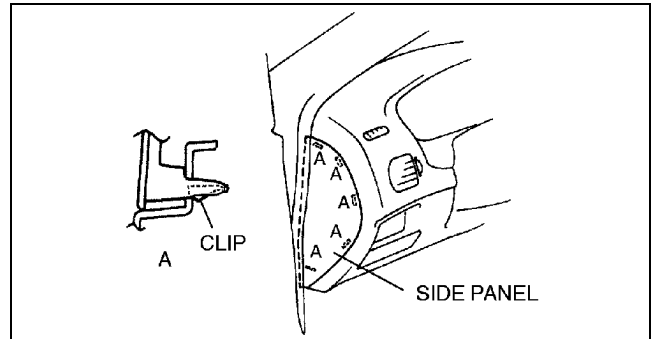

X3U917WAM

## SIDE WALL REMOVAL/INSTALLATION

A3U091768371W01

1. Remove the fastener.
2. Pull the side wall indicated toward the arrow and disengage hook A from the body.
3. Install in the reverse order of removal.

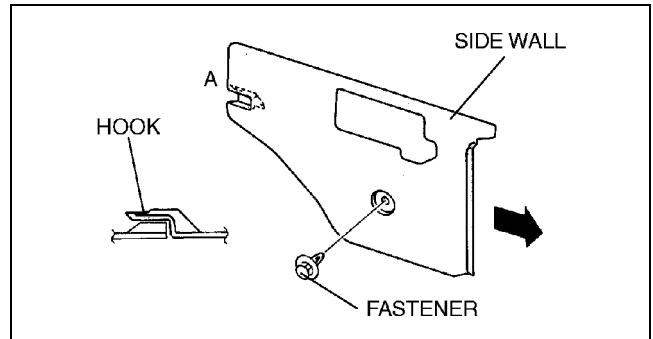

Y3U917WA3

# INTERIOR TRIM

## FRONT DOOR TRIM REMOVAL/INSTALLATION

A3U091768420W01

1. Remove the inner garnish.
2. Remove the regulator handle if equipped.
3. Remove screws A and the fastener.
4. Slide the pull handle cover toward the front of the vehicle, then disengage tab B from the front door trim.
5. Remove the screws C.
6. Disengage clips D using a fastener remover from the body.
7. Pull the front door trim upward, then disengage pins E from the body.
8. Extract the inner handle from the front door trim.
9. Disconnect the power window main switch connector (driver's side).
10. Disconnect the power window sub switch connector (passenger's side).
11. Install in the reverse order of removal.

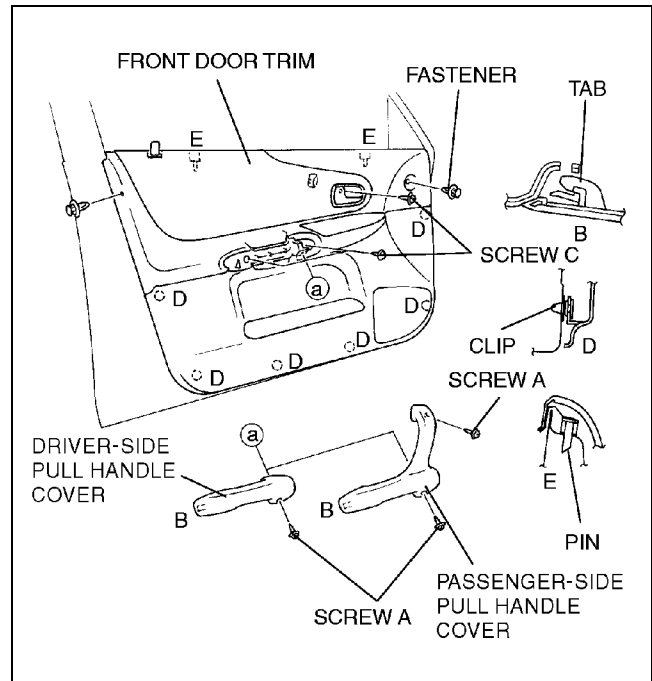

Z3U0917W005

## REAR DOOR TRIM REMOVAL/INSTALLATION

A3U091768520W01

09-17

1. Disconnect the negative battery cable if equipped with power window.
2. Remove the regulator handle if equipped.
3. Insert a tape-wrapped fastener remover under the pull-handle cover, and disengage tab A.

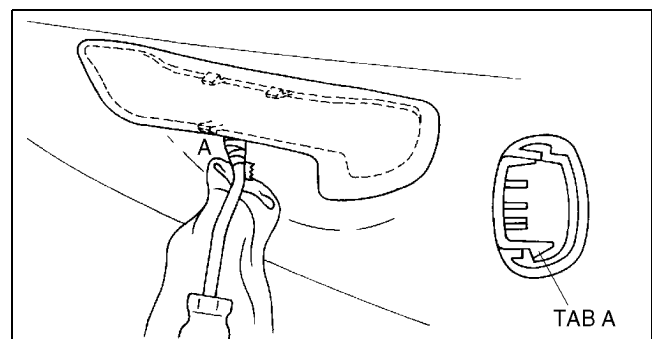

A3U0916W015

4. Insert a tape-wrapped flathead screwdriver into the access hole under the forward pull-handle cover, and remove the pull-handle cover by pulling it upward and diagonally while pushing clip B.

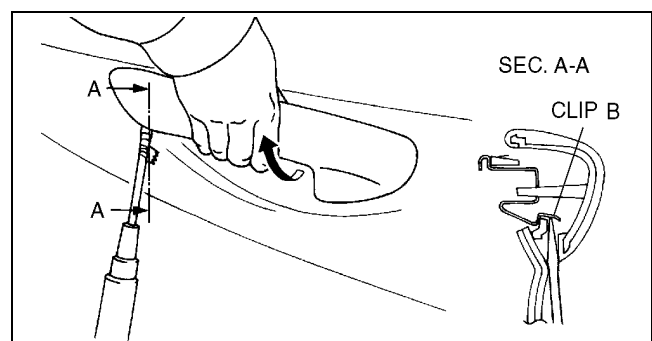

A3U0916W016

## INTERIOR TRIM

5. Remove the screws and fasteners.
6. Disengage clips C using a fastener remover.
7. Pull the rear door trim upward, then disengage pins D from the body.
8. Disconnect the power window sub switch connector if equipped.
9. Remove the inner handle from the rear door trim.
10. Install in the reverse order of removal.

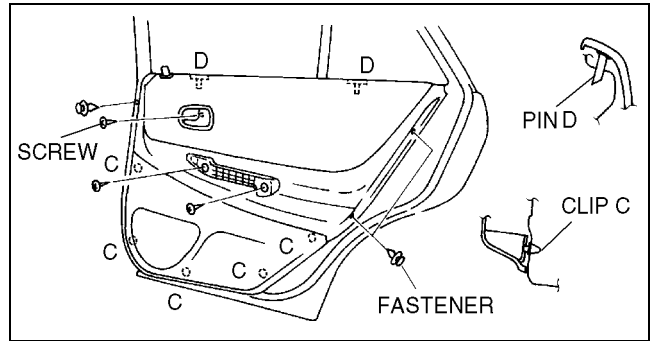

A3U0916W017

### A-PILLAR TRIM REMOVAL/INSTALLATION

A3U091768160W01

1. Turn the seaming welt over.
2. Disengage clips A and B using a fastener remover.
3. Pull the A-pillar trim upward, then disengage hooks C and D.
4. Install in the reverse order of removal.

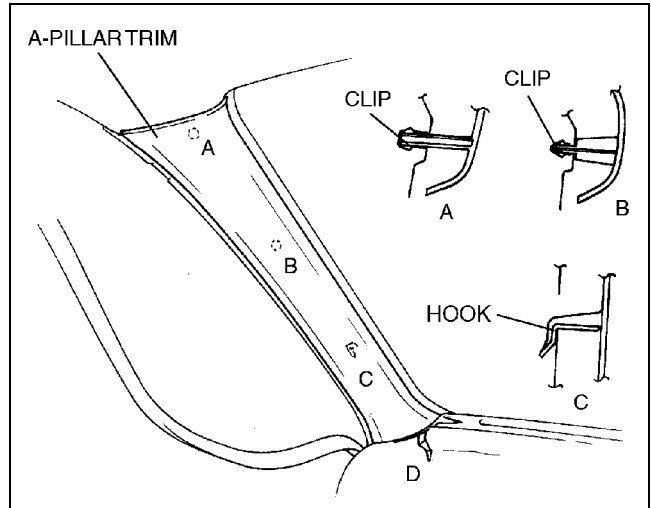

Y3U917WA5

### B-PILLAR LOWER TRIM REMOVAL

A3U091768220W01

#### Warning

- Handling the side air bag sensor improperly can accidentally deploy the side air bag module, which may seriously injure you. Read AIR BAG SYSTEM SERVICE WARNINGS before working around the B-pillar areas. (See 08-10-3 AIR BAG SYSTEM SERVICE WARNINGS.)

#### Note

- The side air bag sensor is located in the B-pillar.

1. Disconnect the negative battery cable.
2. Remove the front scuff plate.
3. Remove the rear scuff plate.
4. Pull the area marked A, then remove one side of the B-pillar lower trim.

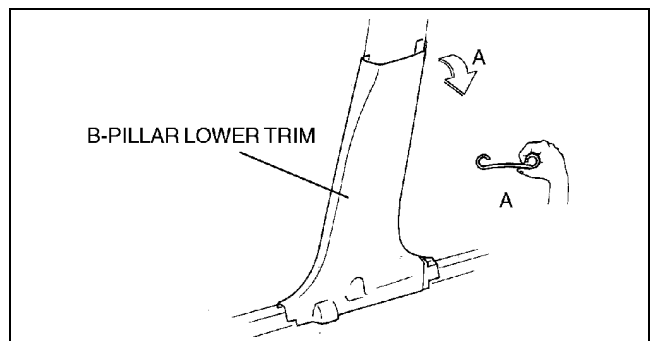

X3U917WAS



# INTERIOR TRIM

## B-PILLAR LOWER TRIM INSTALLATION

A3U091768220W02

### Warning

- Handling the side air bag sensor improperly can accidentally deploy the side air bag module, which may seriously injure you. Read AIR BAG SYSTEM SERVICE WARNINGS before working around the B-pillar areas. (See 08-10-3 AIR BAG SYSTEM SERVICE WARNINGS.)

### Note

- The side air bag sensor is located in the B-pillar.

1. Disconnect the negative battery cable.
2. Install the B-pillar lower trim to the B-pillar with setting 5—10 mm {0.20—0.39 in} upward from its original installation place.
3. Slide the B-pillar lower trim downward.
4. Install the rear scuff plate.
5. Install the front scuff plate.

## B-PILLAR UPPER TRIM REMOVAL/INSTALLATION

A3U091768210W01

1. Remove the upper anchor of the front seat belt. (See 08-11-1 FRONT SEAT BELT REMOVAL/INSTALLATION.)
2. Remove the B-pillar lower trim. (See 09-17-10 B-PILLAR LOWER TRIM REMOVAL.) (See 09-17-11 B-PILLAR LOWER TRIM INSTALLATION.)
3. Turn the seaming welt over.
4. Disengage clip A using a fastener remover.
5. Pull the B-pillar upper trim upward, then disengage hooks B from the body.
6. Install in the reverse order of removal.

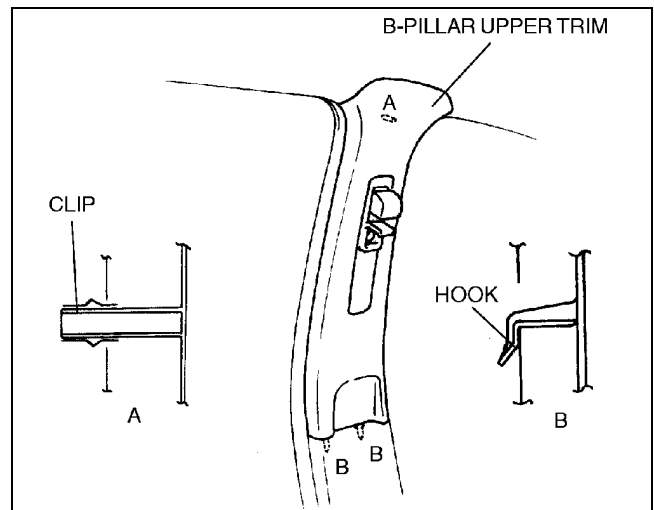

Y3U917WA6

09-17

## C-PILLAR TRIM REMOVAL/INSTALLATION

A3U091768240W01

### 4SD

1. Remove the tire house trim.
2. Turn the seaming welt over.
3. Disengage clips A and pin B using a fastener remover.
4. Pull the C-pillar trim upward, then disengage hook C from the body.
5. Install in the reverse order of removal.

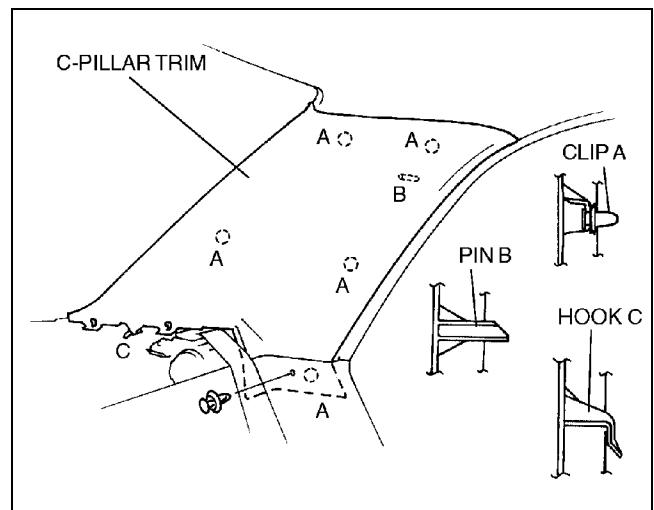

Y3U917WA7

09-17-11

# INTERIOR TRIM

## 5HB

1. Remove the trunk side trim.
2. Remove the rear center seat belt upper anchor installation bolt. (LH only)
3. Remove the fastener.
4. Disengage clips A and pins B using a fastener remover.
5. Pull the C-pillar trim upward, then disengage hooks C from the body.
6. Install in the reverse order of removal.

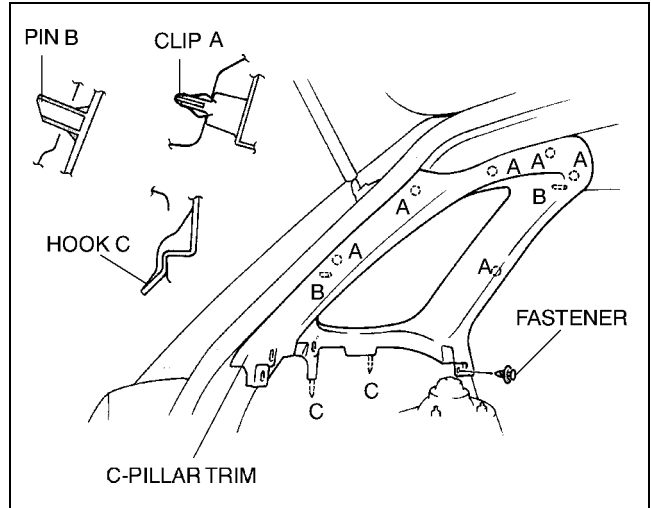

A3U0917W001

## REAR PACKAGE TRIM REMOVAL/INSTALLATION

### 4SD

1. Remove the rear seat back.
2. Pull the rear package trim upward, then disengage clips A, pins B and tabs C from the body.
3. Pull the rear package trim toward you, then disengage tabs D from the body.
4. Install in the reverse order of removal.

A3U091768320W01

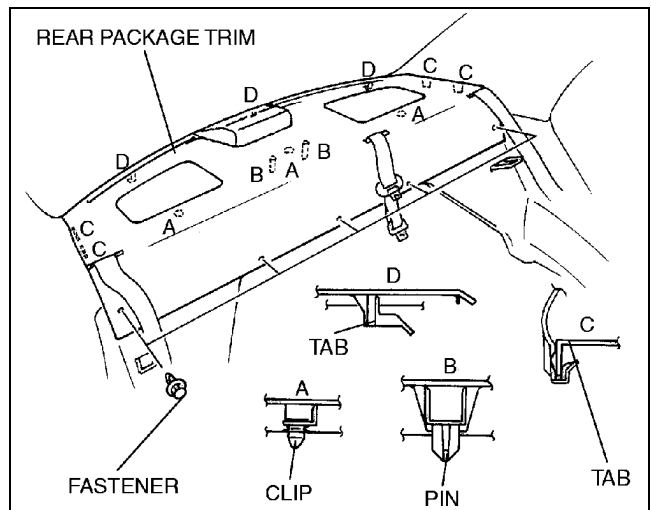

Z3U0917W001

## 5HB

1. Remove the straps from the strap hangers.
2. Pull the rear package trim, then remove the hinge pin from the trunk side trim.
3. Install in the reverse order of removal.

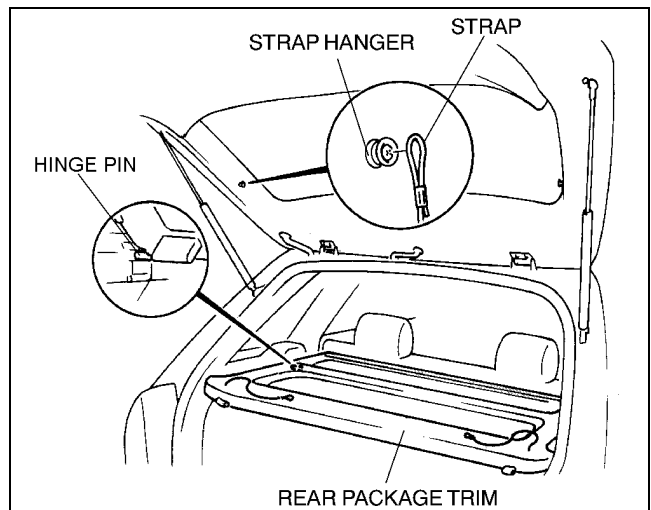

A3U0917W003

## INTERIOR TRIM

### FRONT SCUFF PLATE REMOVAL/INSTALLATION

1. Pull the front scuff plate upward, then disengage clips A from the body.
2. Install in the reverse order of removal.

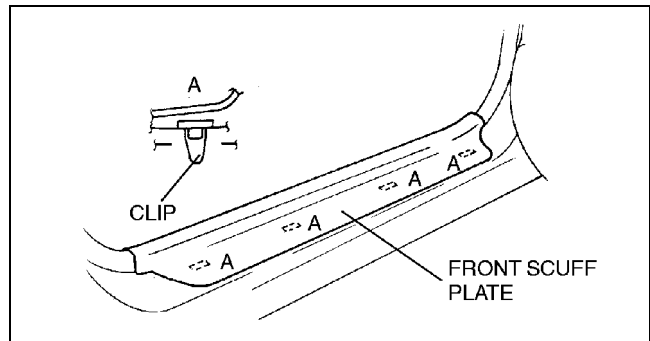

X3U917WAW

### REAR SCUFF PLATE REMOVAL/INSTALLATION

1. Pull the rear scuff plate upward, then disengage clips A and B from the body.
2. Install in the reverse order of removal.

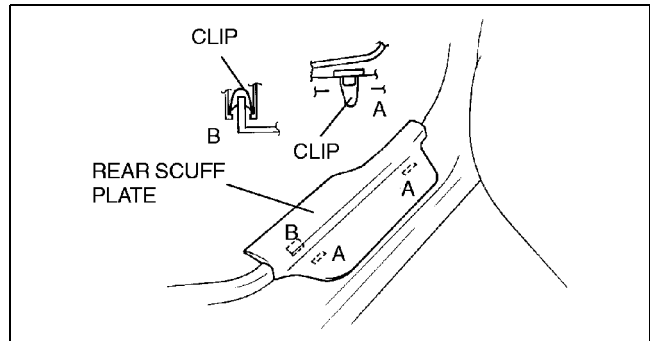

X3U917WAX

### FRONT SIDE TRIM REMOVAL/INSTALLATION

1. Remove the front scuff plate.
2. Turn the seaming welt over.
3. Remove the fasteners.
4. Pull the front side trim toward you, then disengage clip A, pins B and C from the body.
5. Install in the reverse order of removal.

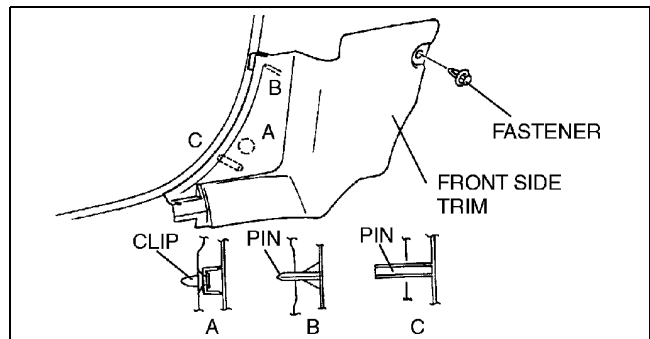

X3U917WAY

A3U091768760W01

### TIRE HOUSE TRIM REMOVAL/INSTALLATION 4SD

1. Remove the rear seat back.
2. Remove the rear scuff plate.
3. Remove the rear package trim.
4. Remove the lower anchor installation bolt from the rear seat belt.
5. Remove the fasteners.
6. Pull the tire house trim forward, then remove the tire house trim.
7. Install in the reverse order of removal.

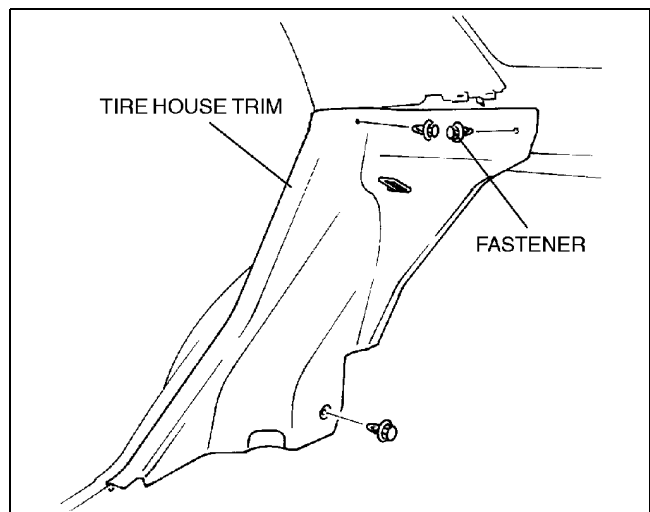

X3U917WAZ

# INTERIOR TRIM

## 5HB

1. Lift up the rear seat cushion.
2. Remove the rear seat back.
3. Remove the rear scuff plate.
4. Remove the fasteners.
5. Pull the tire house trim forward, then remove the tire house trim.
6. Install in the reverse order of removal.

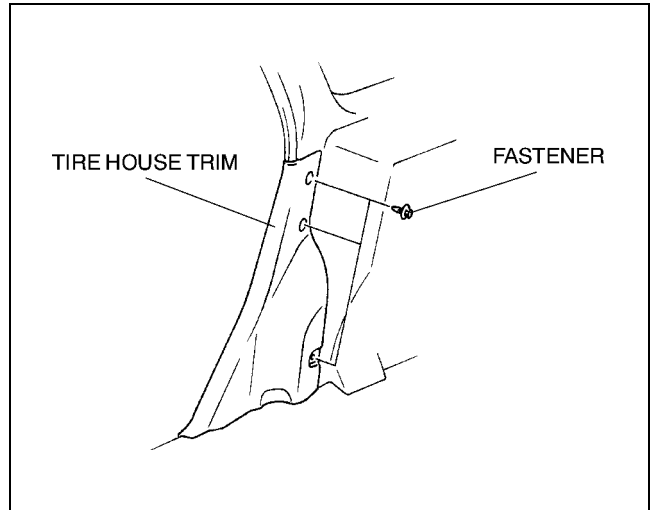

A3U0917W002

## TRUNK END TRIM REMOVAL/INSTALLATION

1. Turn the weatherstrip over.
2. Remove the fasteners.
3. Disengage clips A using a fastener remover from the body.
4. Pull the trunk end trim upward, then disengage pins B and C from the body.
5. Install in the reverse order of removal.

A3U091768890W01

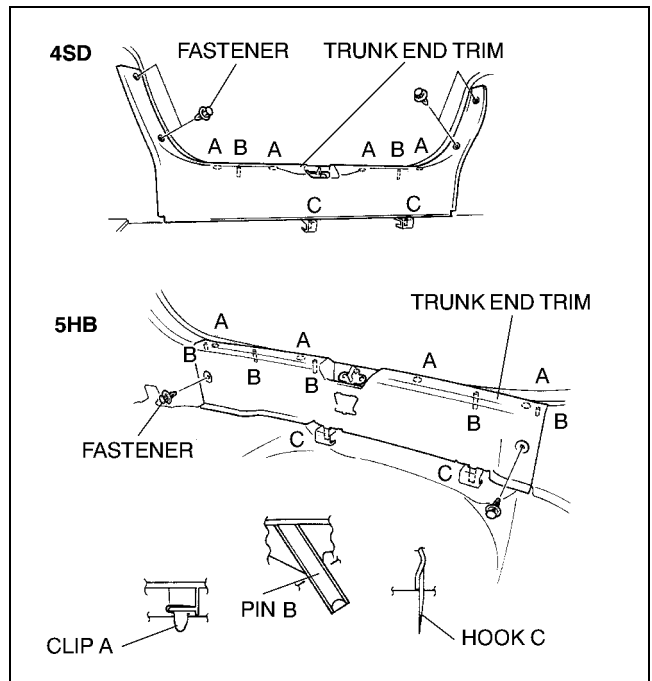

A3U0917W006

# INTERIOR TRIM

## TRUNK SIDE TRIM REMOVAL/INSTALLATION

A3U091768860W01

### 4SD

1. Remove the trunk mat.
2. Remove the trunk end trim.
3. Remove the tire house trim.
4. Remove the fasteners, then remove the belt.
5. Pull the trunk side trim outward, then remove it.
6. Install in the reverse order of removal.

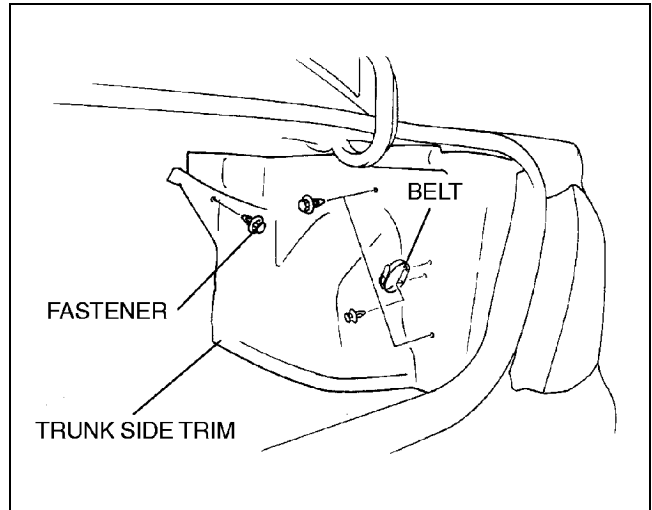

X3U917WB1

### 5HB

1. Remove the trunk end trim.
2. Turn over the weatherstrip.
3. Remove the trunk side upper trim.
4. Remove the tire house trim.
5. Remove the fasteners.
6. Remove the trunk side trim, then disengage clips A.
7. Disconnect the cargo compartment light connector. (LH only)
8. Install in the reverse order of removal.

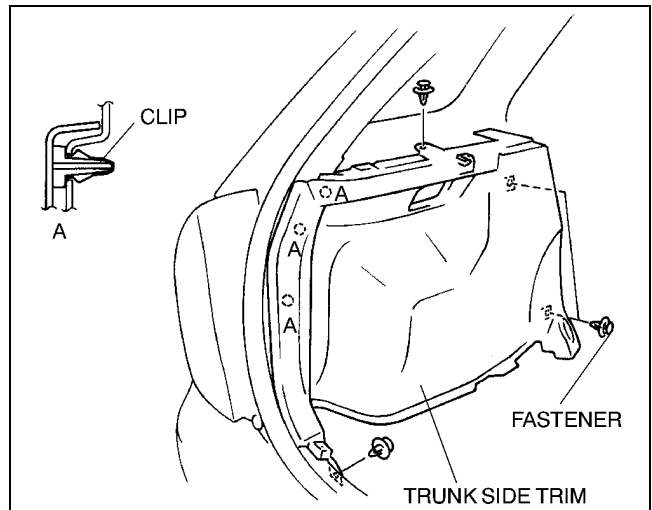

A3U0917W005

## TRUNK SIDE UPPER TRIM REMOVAL/INSTALLATION

A3U091768860W02

1. Remove the rear package trim.
2. Pull the trunk side upper trim upward, then disengage clips A and B from the body.
3. Lift up the rear seat cushion.
4. Remove the rear seat belt lower anchor installation bolts.
5. Install in the reverse order of removal.

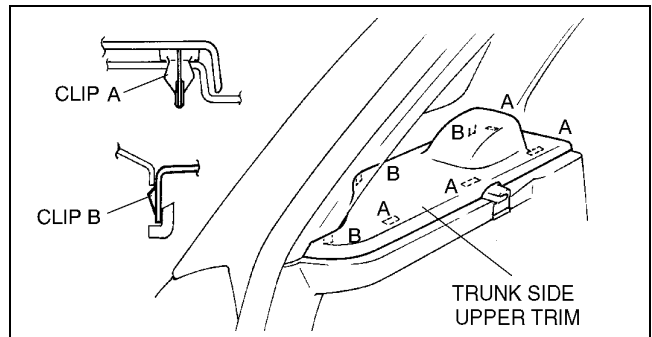

A3U0917W004

# INTERIOR TRIM

## LIFTGATE TRIM REMOVAL/INSTALLATION

A3U091768961W01

1. Disengage clips A and pins B using a fastener remover, then remove the liftgate trim.
2. Install in the reverse order of removal.

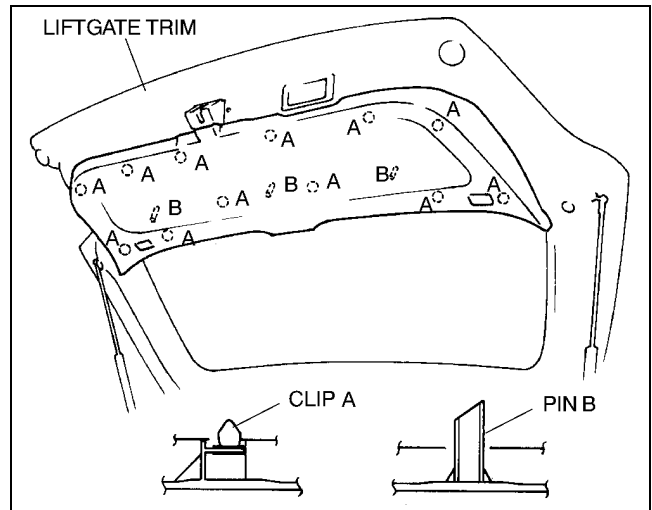

A3U0917W007

## HEADLINER REMOVAL/INSTALLATION

A3U091768030W01

1. Disconnect the negative battery cable.
2. Turn the seaming welt and weatherstrip over.
3. Remove the A-pillar trims. (See 09-17-10 A-PILLAR TRIM REMOVAL/INSTALLATION.)
4. Remove the B-pillar upper trims. (See 09-17-11 B-PILLAR UPPER TRIM REMOVAL/INSTALLATION.)
5. Remove the C-pillar trims. (See 09-17-11 C-PILLAR TRIM REMOVAL/INSTALLATION.)
6. Remove the interior and map light if not equipped with a sliding sunroof. (See 09-18-20 INTERIOR AND MAP LIGHT REMOVAL/INSTALLATION.)
7. Remove the map light and interior light if equipped with a sliding sunroof. (See 09-18-22 INTERIOR LIGHT REMOVAL/INSTALLATION.) (See 09-18-21 MAP LIGHT REMOVAL/INSTALLATION.)
8. Remove the screws then remove the sunvisor and assist handle.
9. Fold tabs A up if equipped with a sliding sunroof.
10. Remove the fasteners.

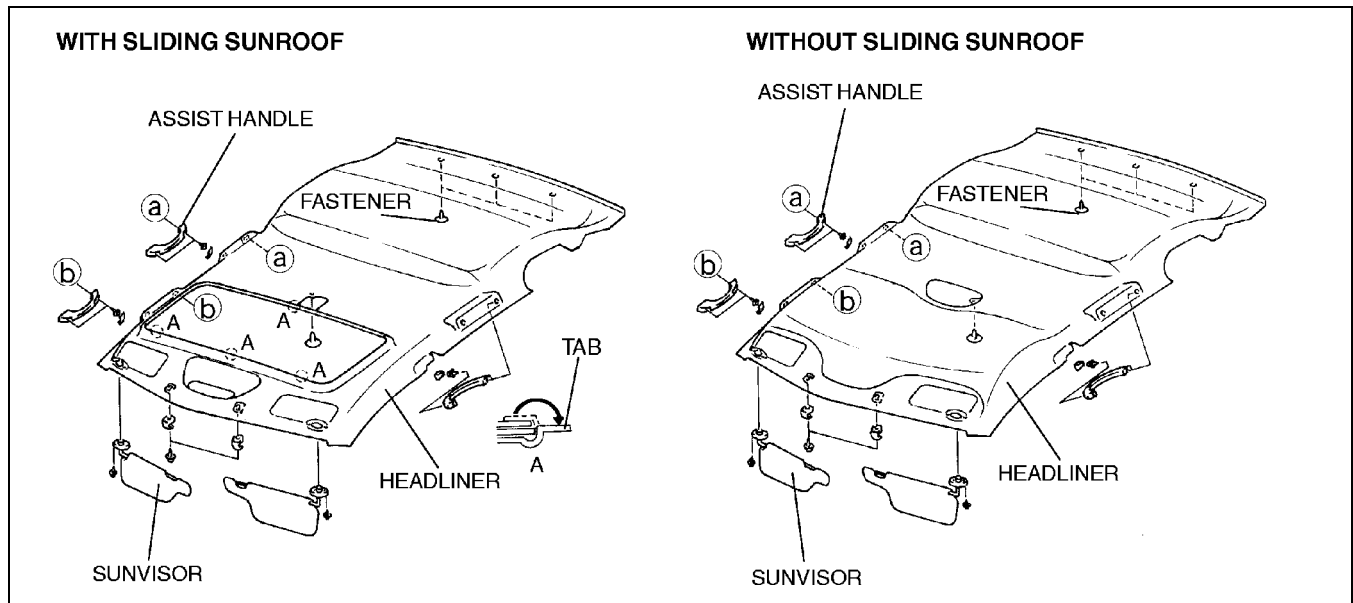

Z3U0917W002

## INTERIOR TRIM

11. Remove the headliner diagonally from the passenger-side front door frame.

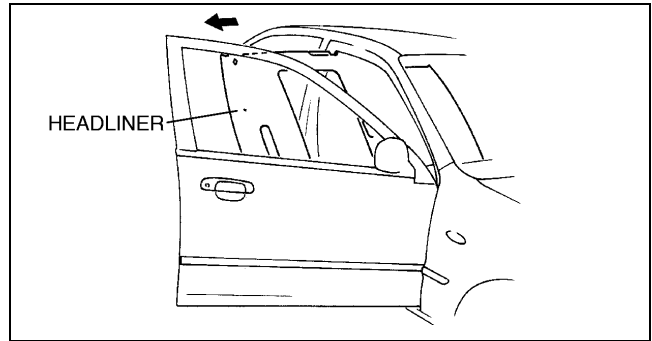

X3U917WB5

### Caution

- To protect the trim, seaming welt, etc. from scratches when removing the headliner from the vehicle, affix protective tape to the console, shift lever knob and door frame.

12. Install in the reverse order of removal.

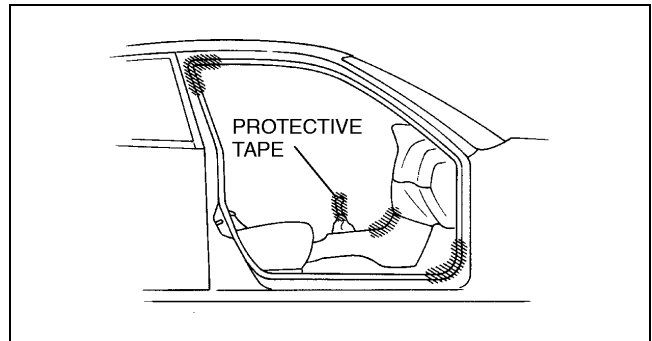

X3U917WB4

## FLOOR COVERING REMOVAL/INSTALLATION

A3U091768670W01

1. Disconnect the negative battery cable.
2. Remove the front seats. (See 09-13-1 FRONT SEAT REMOVAL/INSTALLATION.)
3. Remove the rear seat cushion. (See 09-13-5 REAR SEAT REMOVAL/INSTALLATION.)
4. Remove the tire house trim. (See 09-17-13 TIRE HOUSE TRIM REMOVAL/INSTALLATION.)
5. Remove the dashboard. (See 09-17-1 DASHBOARD REMOVAL/INSTALLATION.)
6. Remove the front side trim. (See 09-17-13 FRONT SIDE TRIM REMOVAL/INSTALLATION.)
7. Remove the B-pillar lower trim. (See 09-17-10 B-PILLAR LOWER TRIM REMOVAL.) (See 09-17-11 B-PILLAR LOWER TRIM INSTALLATION.)
8. Remove the lower anchor of the front seat belt installation bolts.
9. Remove the selector cable if equipped with ATX. (See 05-18-3 SELECTOR LEVER REMOVAL/INSTALLATION.)
10. Remove the interlock cable if equipped with ATX. (See 05-18-3 SELECTOR LEVER REMOVAL/INSTALLATION.)
11. Remove the rear heat duct.
12. Remove the fasteners and clips A, then remove the floor covering.
13. Remove the floor covering from the vehicle through the passenger-side front door.
14. Install in the reverse order of removal.

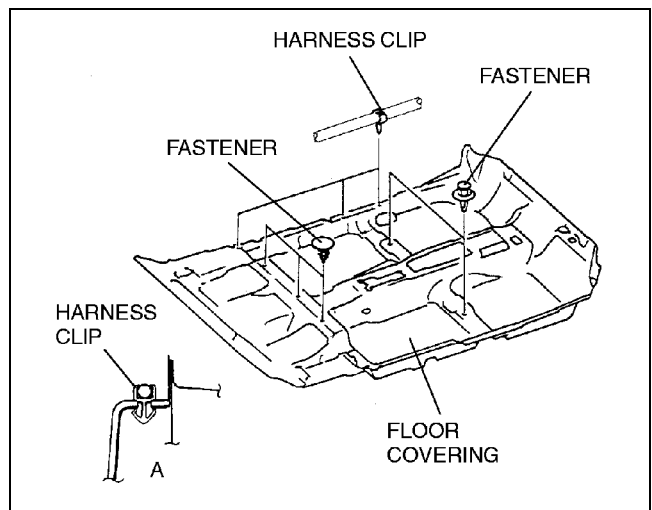

X3U917WB6

## **09-18 LIGHTING SYSTEMS**

<b>LOCATION INDEX</b> .....	09-18-2	<b>BACK-UP LIGHT SWITCH</b>	
<b>FRONT COMBINATION LIGHT</b>		<b>REMOVAL/INSTALLATION</b> .....	09-18-15
<b>REMOVAL/INSTALLATION</b> .....	09-18-5	<b>BACK-UP LIGHT SWITCH INSPECTION</b>	09-18-15
<b>HEADLIGHT ADJUSTMENT</b> .....	09-18-5	<b>FLASHER CONTROL MODULE</b>	
<b>HEADLIGHT BULB</b>		<b>REMOVAL/INSTALLATION</b> .....	09-18-16
<b>REMOVAL/INSTALLATION</b> .....	09-18-6	<b>FLASHER CONTROL MODULE</b>	
Headlight Bulb Removal Note		<b>INSPECTION</b> .....	09-18-16
(4SD and 5HB Low-beam).....	09-18-6	Terminal Voltage List (Reference) .....	09-18-16
Headlight Bulb Removal Note		<b>DAYTIME RUNNING LIGHT (DRL)</b>	
(5HB High-beam).....	09-18-6	<b>SYSTEM WIRING DIAGRAM</b> .....	09-18-17
Cover Installation Note.....	09-18-6	<b>DRL CONTROL MODULE</b>	
<b>FRONT TURN LIGHT/PARKING LIGHT BULB</b>		<b>REMOVAL/INSTALLATION (CANADA)</b>	09-18-18
<b>REMOVAL/INSTALLATION</b> .....	09-18-7	<b>DRL CONTROL MODULE INSPECTION</b>	
<b>FRONT SIDE MARKER LIGHT</b>		(CANADA) .....	09-18-18
<b>REMOVAL/INSTALLATION</b> .....	09-18-7	Terminal Voltage List (Reference) .....	09-18-18
4SD .....	09-18-7	<b>INTERIOR AND MAP LIGHT</b>	
5HB .....	09-18-7	<b>REMOVAL/INSTALLATION</b> .....	09-18-20
<b>FRONT FOG LIGHT</b>		Lens Removal Note.....	09-18-20
<b>REMOVAL/INSTALLATION</b> .....	09-18-8	<b>INTERIOR AND MAP LIGHT</b>	
4SD .....	09-18-8	<b>INSPECTION</b> .....	09-18-20
5HB .....	09-18-8	<b>MAP LIGHT REMOVAL/INSTALLATION</b>	09-18-21
<b>FRONT FOG LIGHT ADJUSTMENT</b> ....	09-18-9	Lens Removal Note.....	09-18-21
<b>REAR COMBINATION LIGHT</b>		<b>MAP LIGHT INSPECTION</b> .....	09-18-21
<b>REMOVAL/INSTALLATION</b> .....	09-18-10	<b>INTERIOR LIGHT</b>	
Socket Installation Note .....	09-18-10	<b>REMOVAL/INSTALLATION</b> .....	09-18-22
<b>HIGH-MOUNT BRAKE LIGHT</b>		Lens Removal Note.....	09-18-22
<b>REMOVAL/INSTALLATION</b> .....	09-18-11	<b>INTERIOR LIGHT INSPECTION</b> .....	09-18-22
In-Vehicle Type .....	09-18-11	<b>TRUNK COMPARTMENT LIGHT BULB</b>	
Rear Spoiler Type .....	09-18-11	<b>REMOVAL/INSTALLATION</b> .....	09-18-23
<b>LICENSE PLATE LIGHT</b>		<b>TRUNK COMPARTMENT LIGHT SWITCH</b>	
<b>REMOVAL/INSTALLATION</b> .....	09-18-12	<b>INSPECTION</b> .....	09-18-23
License Plate Light Removal Note....	09-18-12	<b>CARGO COMPARTMENT LIGHT</b>	
<b>COMBINATION SWITCH</b>		<b>REMOVAL/INSTALLATION</b> .....	09-18-23
<b>REMOVAL/INSTALLATION</b> .....	09-18-12	<b>CARGO COMPARTMENT LIGHT</b>	
<b>COMBINATION SWITCH DISASSEMBLY/ ASSEMBLY</b> .....	09-18-13	<b>INSPECTION</b> .....	09-18-24
<b>LIGHT SWITCH</b>		<b>CARGO COMPARTMENT LIGHT SWITCH</b>	
<b>REMOVAL/INSTALLATION</b> .....	09-18-13	<b>INSPECTION</b> .....	09-18-24
<b>LIGHT SWITCH INSPECTION</b> .....	09-18-13	<b>IGNITION KEY ILLUMINATION BULB</b>	
Headlight switch.....	09-18-13	<b>REMOVAL/INSTALLATION</b> .....	09-18-24
Turn switch.....	09-18-14	<b>DOOR SWITCH</b>	
<b>FRONT FOG LIGHT SWITCH</b>		<b>REMOVAL/INSTALLATION</b> .....	09-18-24
<b>REMOVAL/INSTALLATION</b> .....	09-18-14	Front .....	09-18-24
<b>FRONT FOG LIGHT SWITCH</b>		Rear .....	09-18-25
<b>INSPECTION</b> .....	09-18-14	<b>DOOR SWITCH INSPECTION</b> .....	09-18-25
<b>HAZARD WARNING SWITCH</b>		<b>PANEL LIGHT CONTROL SWITCH</b>	
<b>REMOVAL/INSTALLATION</b> .....	09-18-14	<b>REMOVAL/INSTALLATION</b> .....	09-18-25
<b>HAZARD WARNING SWITCH</b>		Panel Light Control Switch	
<b>INSPECTION</b> .....	09-18-15	Removal Note .....	09-18-25
		<b>PANEL LIGHT CONTROL SWITCH</b>	
		<b>INSPECTION</b> .....	09-18-26
		Terminal Voltage List (Reference) .....	09-18-26

**09-18**



# LIGHTING SYSTEMS

## LOCATION INDEX

A3U091801051W01

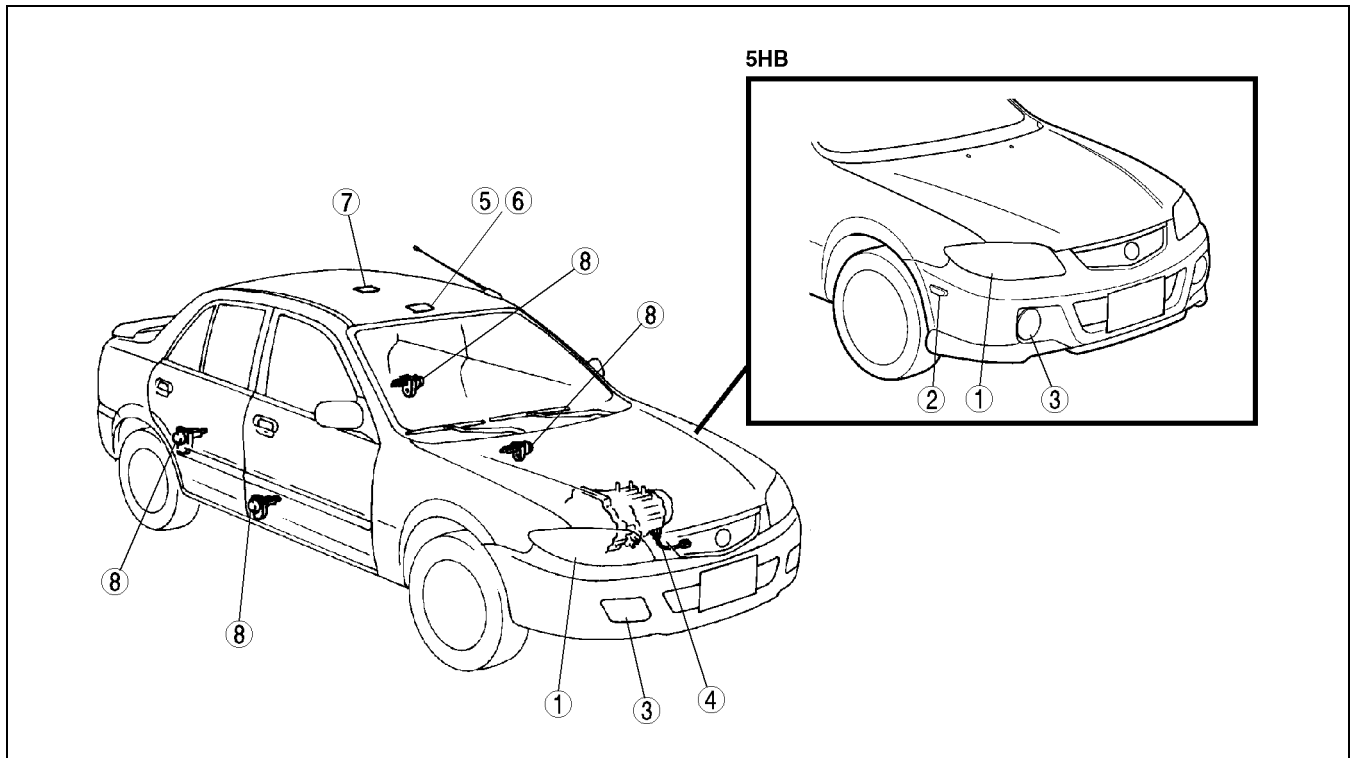

A3U0918W108

1	Front combination light (See 09-18-5 FRONT COMBINATION LIGHT REMOVAL/INSTALLATION) (See 09-18-5 HEADLIGHT ADJUSTMENT) (See 09-18-6 HEADLIGHT BULB REMOVAL/INSTALLATION) (See 09-18-7 FRONT TURN LIGHT/PARKING LIGHT BULB REMOVAL/INSTALLATION) (See 09-18-7 4SD)
2	Front side marker light (5HB) (See 09-18-7 5HB)
3	Front fog light (See 09-18-9 FRONT FOG LIGHT ADJUSTMENT) (See 09-18-8 FRONT FOG LIGHT REMOVAL/INSTALLATION)
4	Back-up light switch (See 09-18-15 BACK-UP LIGHT SWITCH REMOVAL/INSTALLATION) (See 09-18-15 BACK-UP LIGHT SWITCH INSPECTION)

5	Interior and map light (See 09-18-20 INTERIOR AND MAP LIGHT REMOVAL/INSTALLATION) (See 09-18-20 INTERIOR AND MAP LIGHT INSPECTION)
6	Map light (See 09-18-21 MAP LIGHT REMOVAL/INSTALLATION) (See 09-18-21 MAP LIGHT INSPECTION)
7	Interior light (See 09-18-22 INTERIOR LIGHT REMOVAL/INSTALLATION) (See 09-18-22 INTERIOR LIGHT INSPECTION)
8	Door switch (See 09-18-24 DOOR SWITCH REMOVAL/INSTALLATION) (See 09-18-25 DOOR SWITCH INSPECTION)

# LIGHTING SYSTEMS

4SD

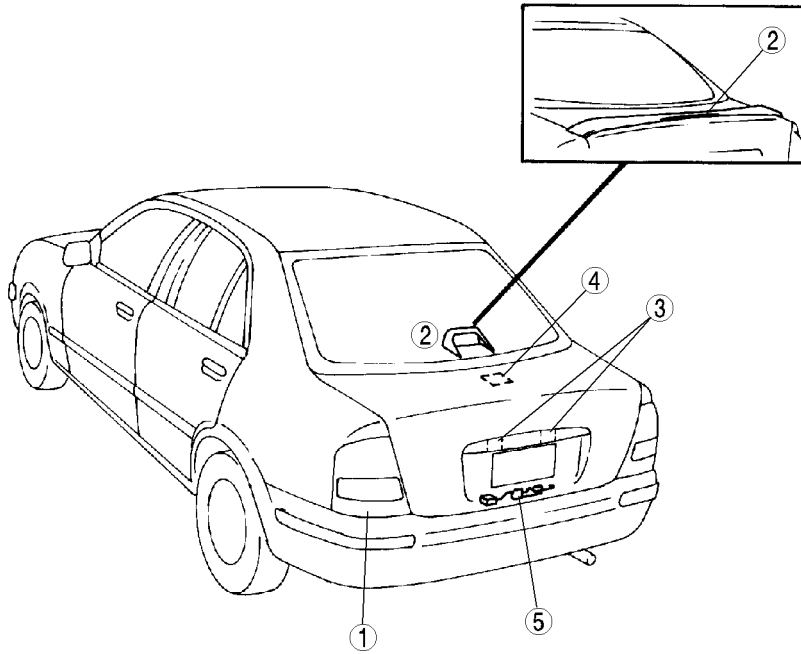

5HB

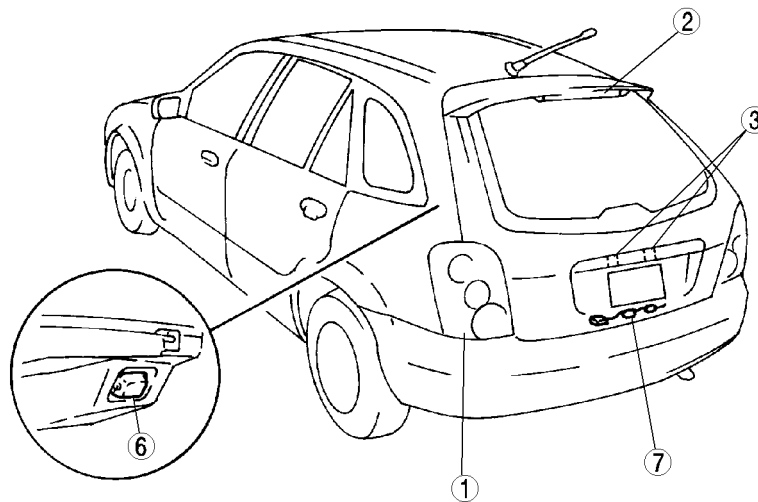

09-18

A3U0918W104

1	Rear combination light (See 09-18-10 REAR COMBINATION LIGHT REMOVAL/INSTALLATION)
2	High-mount brake light (See 09-18-11 HIGH-MOUNT BRAKE LIGHT REMOVAL/INSTALLATION)
3	License plate light (See 09-18-12 LICENSE PLATE LIGHT REMOVAL/INSTALLATION)
4	Trunk compartment light bulb (See 09-18-23 TRUNK COMPARTMENT LIGHT BULB REMOVAL/INSTALLATION)

5	Trunk compartment light switch (See 09-18-23 TRUNK COMPARTMENT LIGHT SWITCH INSPECTION)
6	Cargo compartment light (See 09-18-23 CARGO COMPARTMENT LIGHT REMOVAL/INSTALLATION) (See 09-18-24 CARGO COMPARTMENT LIGHT INSPECTION)
7	Cargo compartment light switch (See 09-18-24 CARGO COMPARTMENT LIGHT SWITCH INSPECTION)

# LIGHTING SYSTEMS

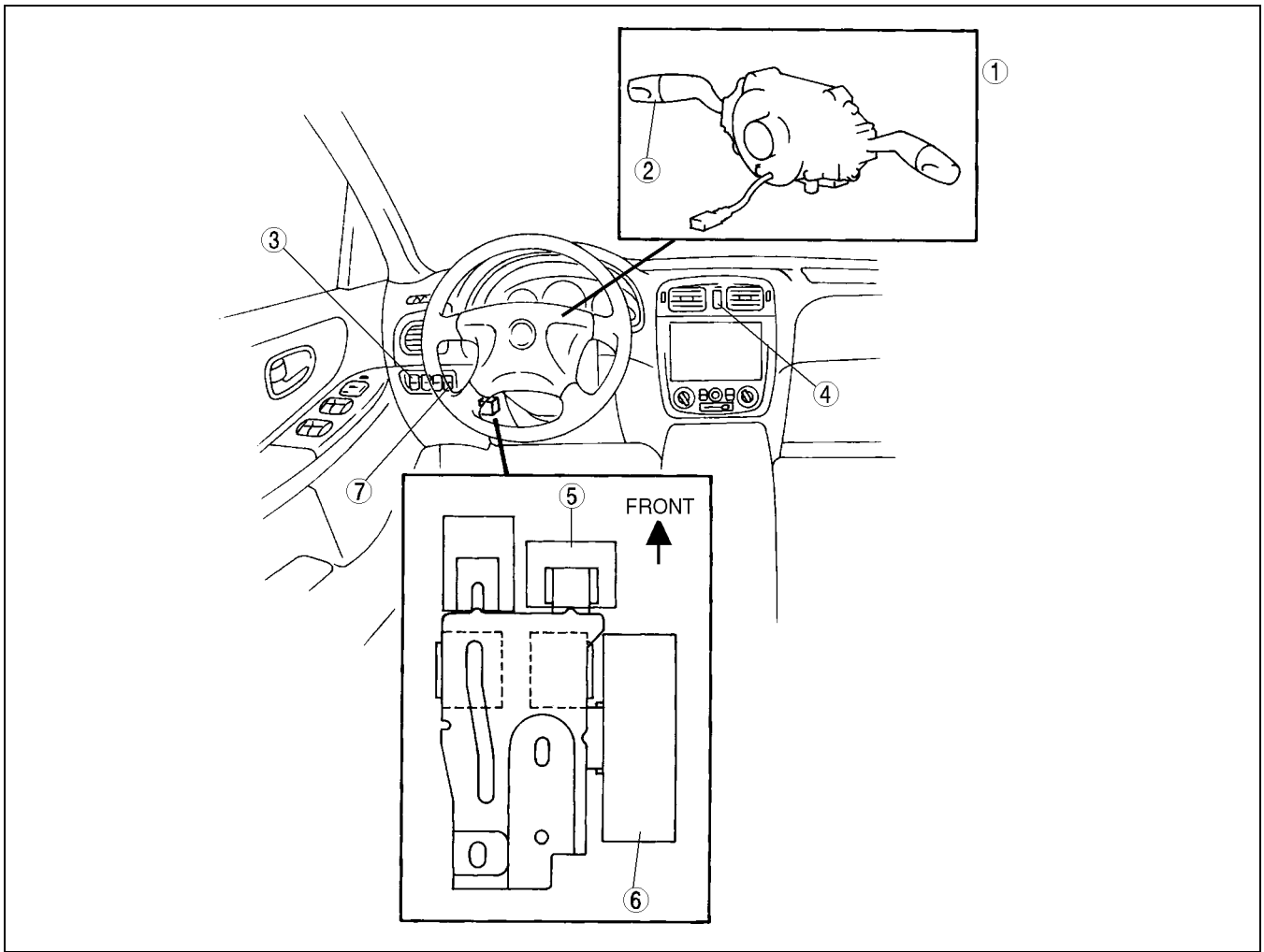

Z3U0918W013

1	Combination switch (See 09-18-12 COMBINATION SWITCH REMOVAL/INSTALLATION) (See 09-18-13 COMBINATION SWITCH DISASSEMBLY/ASSEMBLY)
2	Light switch (See 09-18-13 LIGHT SWITCH REMOVAL/INSTALLATION) (See 09-18-13 LIGHT SWITCH INSPECTION)
3	Front fog light switch (See 09-18-14 FRONT FOG LIGHT SWITCH REMOVAL/INSTALLATION) (See 09-18-14 FRONT FOG LIGHT SWITCH INSPECTION)
4	Hazard warning switch (See 09-18-14 HAZARD WARNING SWITCH REMOVAL/INSTALLATION) (See 09-18-15 HAZARD WARNING SWITCH INSPECTION)

5	Flasher control module (See 09-18-16 FLASHER CONTROL MODULE REMOVAL/INSTALLATION) (See 09-18-16 FLASHER CONTROL MODULE INSPECTION)
6	DRL control module (See 09-18-18 DRL CONTROL MODULE REMOVAL/INSTALLATION (CANADA)) (See 09-18-18 DRL CONTROL MODULE INSPECTION (CANADA))
7	Panel light control switch (See 09-18-25 PANEL LIGHT CONTROL SWITCH REMOVAL/INSTALLATION) (See 09-18-26 PANEL LIGHT CONTROL SWITCH INSPECTION)

# LIGHTING SYSTEMS

## FRONT COMBINATION LIGHT REMOVAL/INSTALLATION

A3U091851060W01

1. Disconnect the negative battery cable.
2. Remove the front bumper. (See 09-10-5 FRONT BUMPER REMOVAL/INSTALLATION.)
3. Remove in the order indicated in the table.

1	Connector
2	Bolt
3	Front combination light

4. Install in the reverse order of removal.
5. Adjust the headlight aiming. (See 09-18-5 HEADLIGHT ADJUSTMENT.)

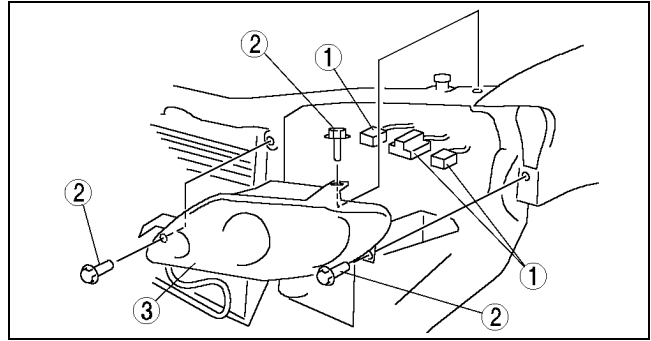

Y3J8112W111

## HEADLIGHT ADJUSTMENT

A3U091851030W01

1. Adjust the tire air pressure to the specification.
2. Position the unloaded vehicle on a flat, level surface.
3. Seat one person in the driver's seat.
4. Position the vehicle straight ahead and perpendicular to a wall.
5. Set the headlights **3 m {10 ft}** from the wall.
6. While adjusting one headlight, disconnect the connector of the other.
7. Start the engine to charge the battery.
8. Turn on the low-beam headlight.

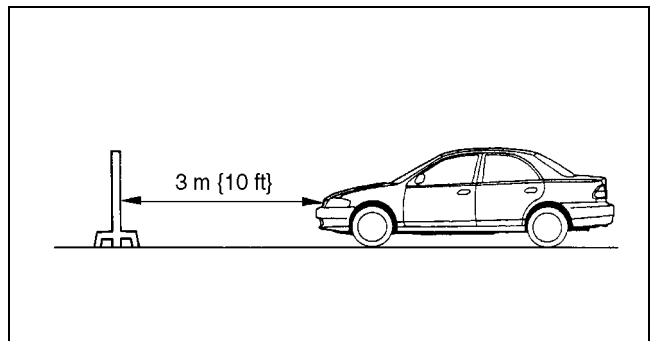

Z3U0918W006

9. Adjust the headlights by turning the adjusting screws as shown in the figure. Loosen the screws first, then tighten them.

### Note

- If the adjusting screws are tightened first, then loosened, they will continue to loosen when the vehicle is in motion and may cause the headlights to become misaligned.

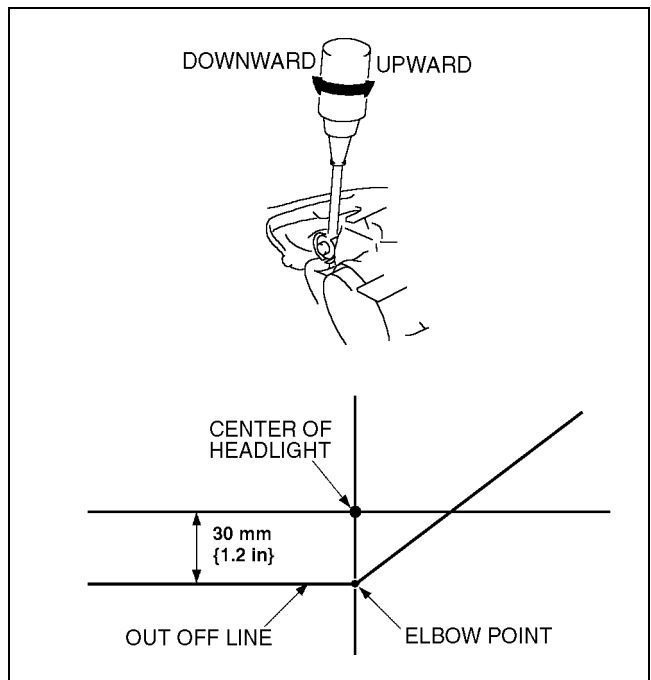

Z3U0918W001

# LIGHTING SYSTEMS

A3U091851030W02

## HEADLIGHT BULB REMOVAL/INSTALLATION

1. Disconnect the negative battery cable.
2. Remove in the order indicated in the table.

### Caution

- A halogen bulb generates extremely high heat when it is used. If the surface of the bulb is dirty, excessive heat will build up and the light's life will be shortened. When replacing the bulb, hold the metal flange, not the glass.

3. Install in the reverse order of removal.

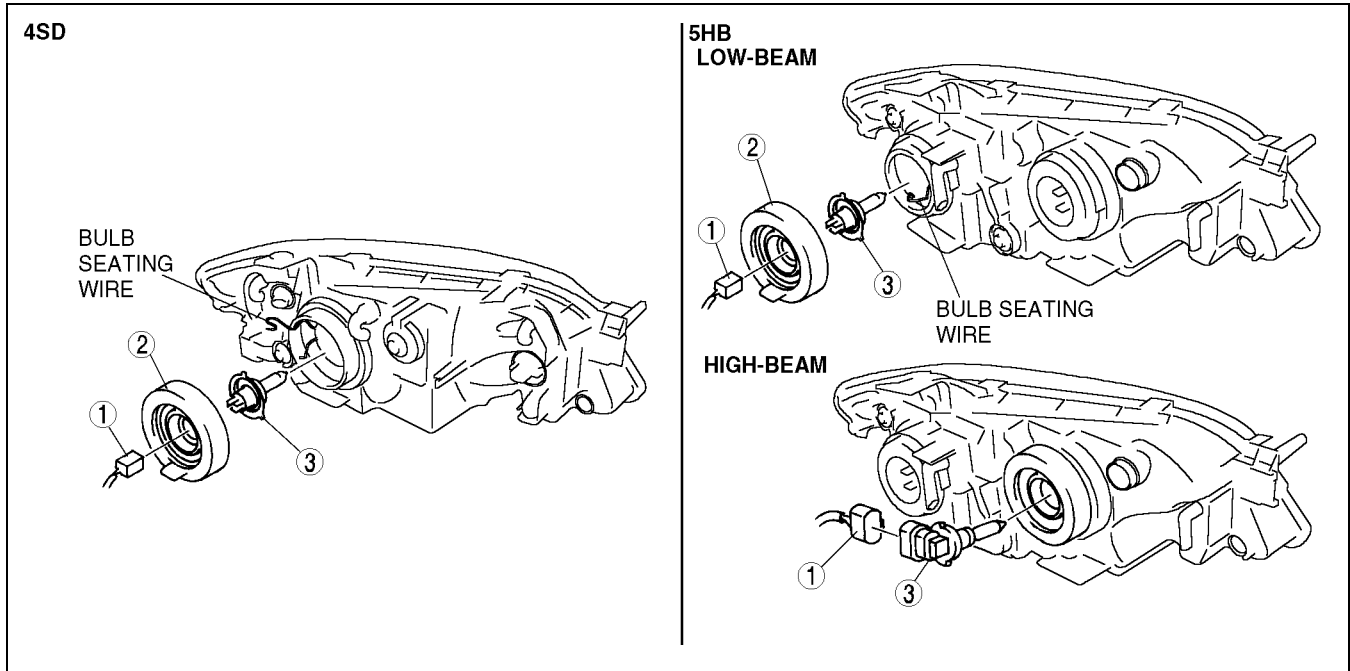

A3U0918W101

1	Connector
2	Cover (See 09-18-6 Cover Installation Note)

3	Headlight bulb (See 09-18-6 Headlight Bulb Removal Note (4SD and 5HB Low-beam)) (See 09-18-6 Headlight Bulb Removal Note (5HB High-beam))
---	---

### Headlight Bulb Removal Note (4SD and 5HB Low-beam)

1. Release the bulb seating wire to remove the headlight bulb.

### Headlight Bulb Removal Note (5HB High-beam)

1. Turn the bulb to remove the headlight bulb.

### Cover Installation Note

1. Make sure the cover is seated properly to prevent the moisture from getting into the headlight housing.

# LIGHTING SYSTEMS

## FRONT TURN LIGHT/PARKING LIGHT BULB REMOVAL/INSTALLATION

A3U091851050W01

1. Disconnect the negative battery cable.
2. Remove in the order indicated in the table.

1	Connector
2	Socket
3	Front turn light/parking light bulb

3. Install in the reverse order of removal.

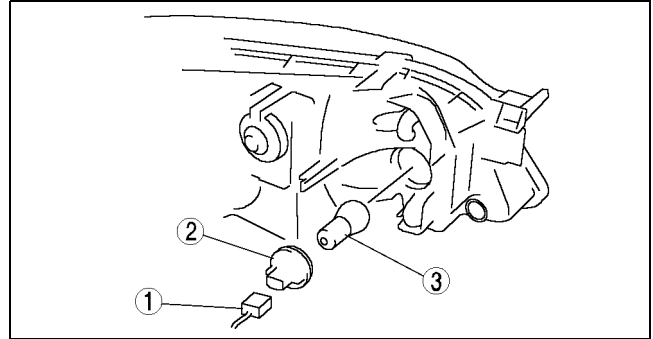

Y3J8112W107

## FRONT SIDE MARKER LIGHT REMOVAL/INSTALLATION

A3U091851120W01

### 4SD

1. Disconnect the negative battery cable.
2. Remove in the order indicated in the table.

1	Socket
2	Connector
3	Front side marker light bulb

3. Install in the reverse order of removal.

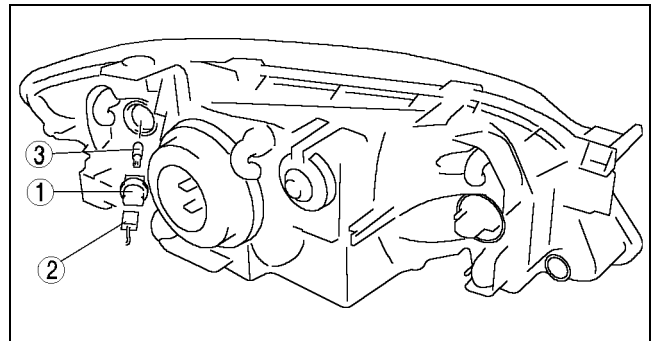

Z3U0918W002

09-18

### 5HB

1. Disconnect the negative battery cable.
2. Remove the bolts and fasteners, and bend the splash shield down.
3. Remove in the order indicated in the table.

1	Front side marker light (See 09-18-7 Front side marker light removal note)
2	Connector
3	Socket
4	Front side marker light bulb

4. Install in the reverse order of removal.

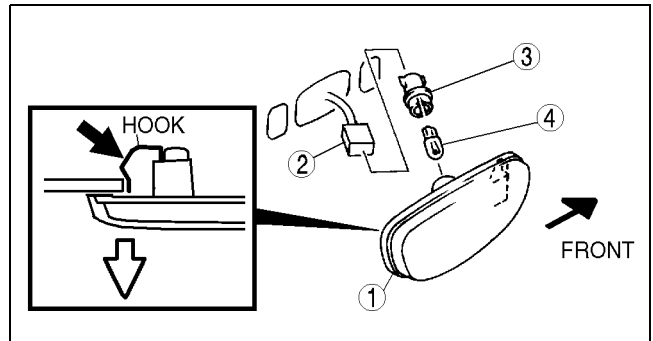

A3U0918W112

### Front side marker light removal note

1. Pull out the rear end of the front side marker light while pressing the hook.

# LIGHTING SYSTEMS

## FRONT FOG LIGHT REMOVAL/INSTALLATION

A3U091851680W01

### 4SD

#### Caution

- A halogen bulb generates extremely high heat when it is used. If the surface of the bulb is dirty, excessive heat will build up and the bulb's life will be shortened. When replacing the bulb, hold the metal flange, not the glass.

1. Disconnect the negative battery cable.
2. Turn over the mud guard.
3. Remove in the order indicated in the table.

1	Bolt
2	Connector
3	Front fog light
4	Screw
5	Cover
6	Bulb pressing wire
7	Front fog light bulb

4. Install in the reverse order of removal.
5. Adjust the front fog light aiming. (See 09-18-9 FRONT FOG LIGHT ADJUSTMENT.)

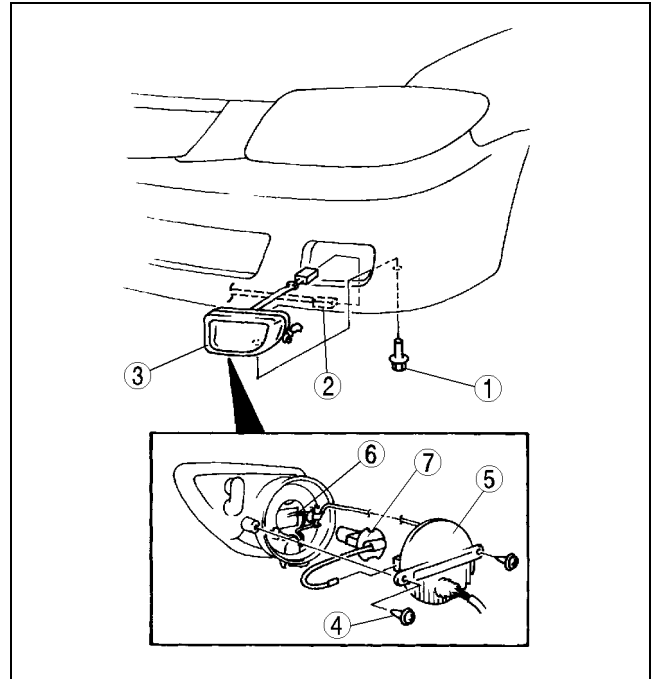

Z3U0918W014

### 5HB

#### Caution

- A halogen bulb generates extremely high heat when it is used. If the surface of the bulb is dirty, excessive heat will build up and the bulb's life will be shortened. When replacing the bulb, hold the metal flange, not the glass.

1. Disconnect the negative battery cable.
2. Remove the front bumper. (See 09-10-5 FRONT BUMPER REMOVAL/INSTALLATION.)
3. Remove in the order indicated in the table.

1	Nut
2	Connector
3	Front fog light
4	Screw
5	Front fog light unit
6	Connector
7	Bulb pressing wire
8	Front fog light bulb

4. Install in the reverse order of removal.
5. Adjust the front fog light aiming. (See 09-18-9 FRONT FOG LIGHT ADJUSTMENT.)

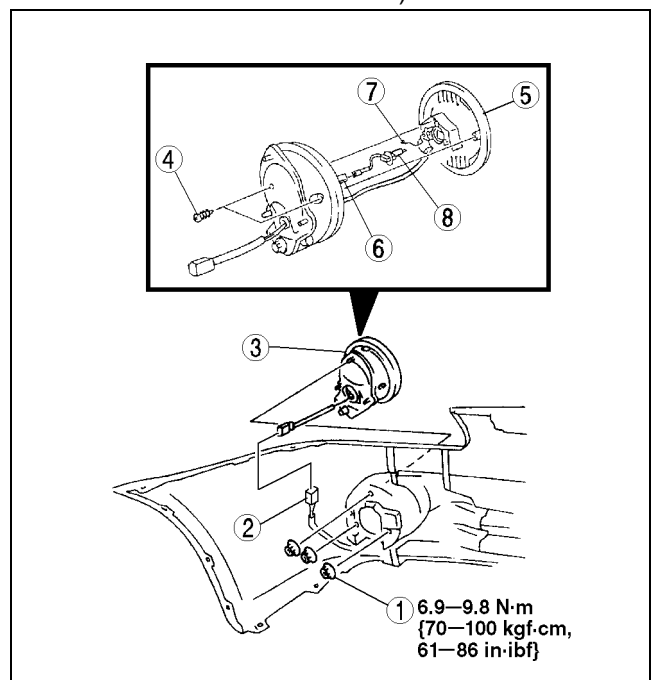

A3U0918W110

# LIGHTING SYSTEMS

## FRONT FOG LIGHT ADJUSTMENT

A3U091851680W02

1. Adjust the tire air pressure to the specification.
2. Position the unloaded vehicle on a flat, level surface.
3. Seat one person in the driver's seat.
4. Position the vehicle **3 m {10 ft}** in front of a white screen.
5. While adjusting one fog light, mask the other.
6. Start the engine to charge the battery.
7. Turn the front fog light on.
8. Peel off the mud guard.
9. Loosen the screw or bolts for the aim adjustment.
10. Move the front fog light in the direction of the arrows indicated in the figure and adjust the center of the front fog light to the position.

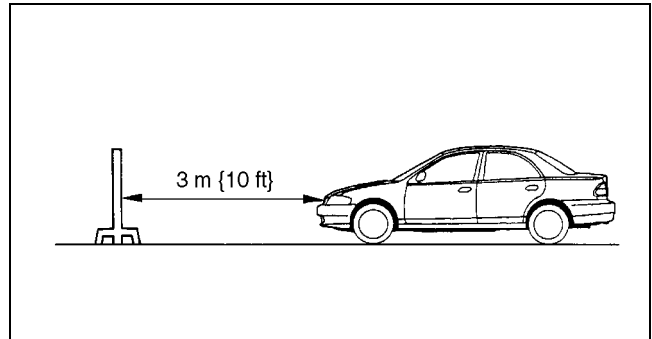

Z3U0918W006

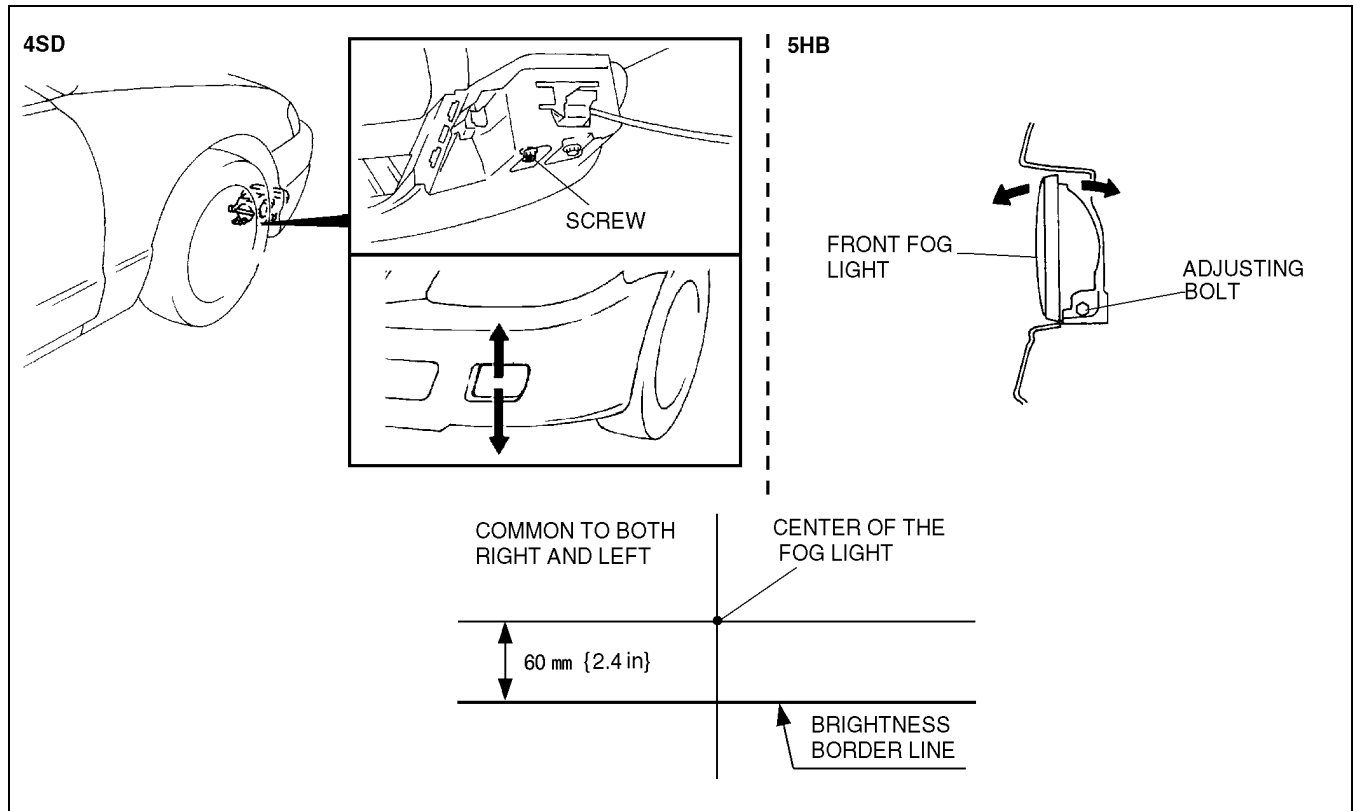

09-18

A3U0918W111

11. Tighten the front fog light adjusting screw or bolts.



# LIGHTING SYSTEMS

## REAR COMBINATION LIGHT REMOVAL/INSTALLATION

A3U091851150W01

1. Disconnect the negative battery cable.
2. Remove the trunk side trim. (See 09-17-15 TRUNK SIDE TRIM REMOVAL/INSTALLATION.)
3. Remove in the order indicated in the table.

1	Connector
2	Nut
3	Rear combination light
4	Socket (See 09-18-10 Socket Installation Note)
5	Brake light/taillight bulb
6	Rear turn light bulb
7	Back-up light bulb
8	Rear side marker light bulb (4SD)
9	Taillight bulb (4SD)

4. Install in the reverse order of removal.

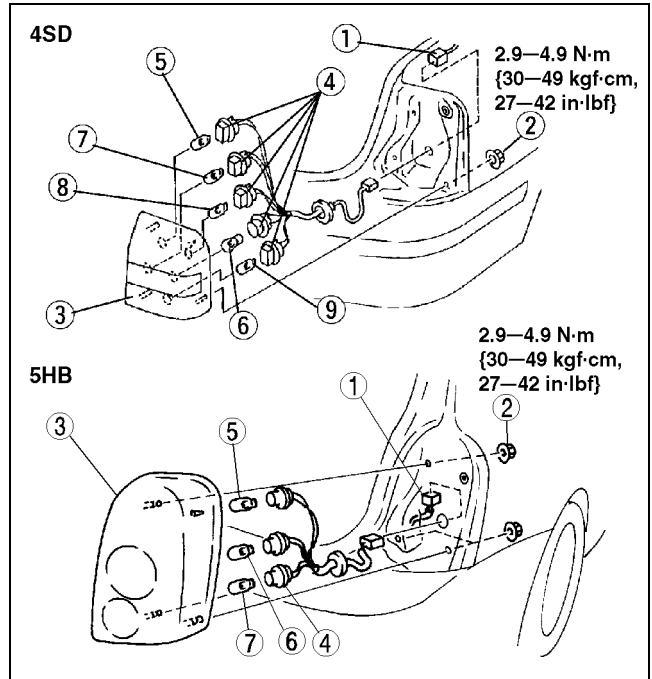

A3U0918W107

### Socket Installation Note

1. Hook the harness as shown in the figure.

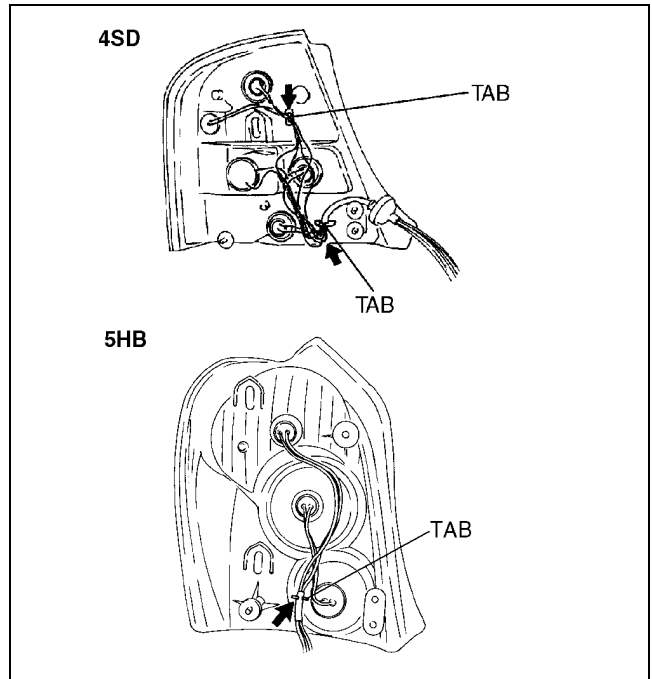

A3U0918W106

# LIGHTING SYSTEMS

## HIGH-MOUNT BRAKE LIGHT REMOVAL/INSTALLATION

A3U091851580W01

### In-Vehicle Type

1. Disconnect the negative battery cable.
2. Remove the rear package trim. (See 09–17–12 REAR PACKAGE TRIM REMOVAL/INSTALLATION.)
3. Remove in the order indicated in the table.

1	High-mount brake light
2	Lens
3	Socket
4	High-mount brake light bulb

4. Install in the reverse order of removal.

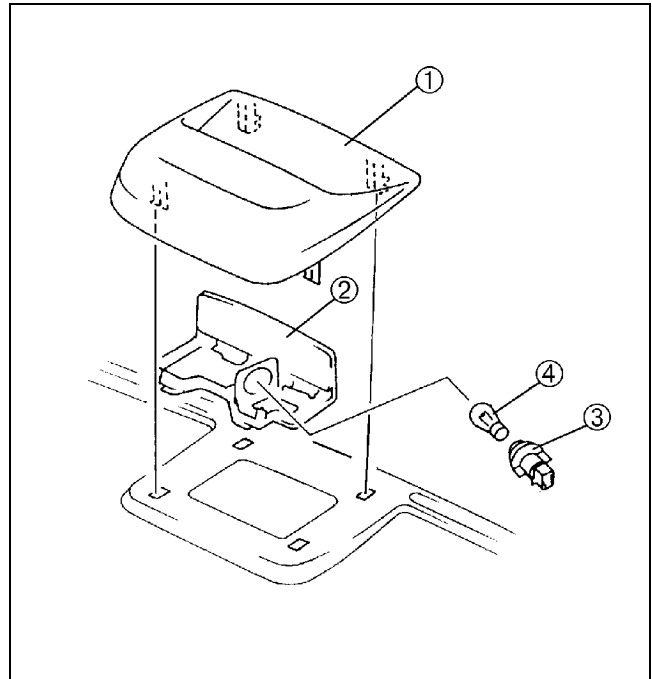

Y3U918WAM

09–18

### Rear Spoiler Type

1. Disconnect the negative battery cable.
2. Remove the rear spoiler. (See 09–16–8 REAR SPOILER REMOVAL/INSTALLATION.)
3. Remove in the order indicated in the table.

1	Screw
2	High-mount brake light (See 09–18–12 High-mount brake light removal note (4SD))

4. Install in the reverse order of removal.

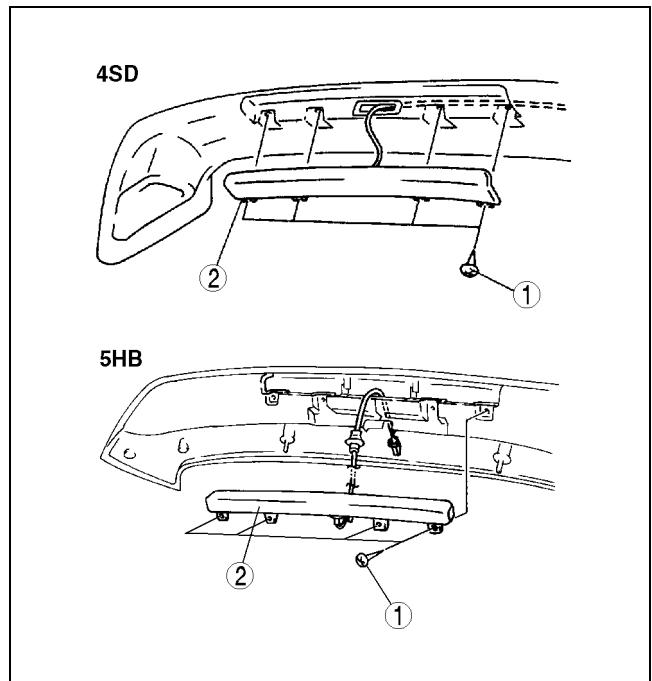

A3U0918W102

# LIGHTING SYSTEMS

## High-mount brake light removal note (4SD)

1. Tie a string to the end of the connector of the high-mount brake light beforehand so that the connector can be passed easily through the rear spoiler during installation.

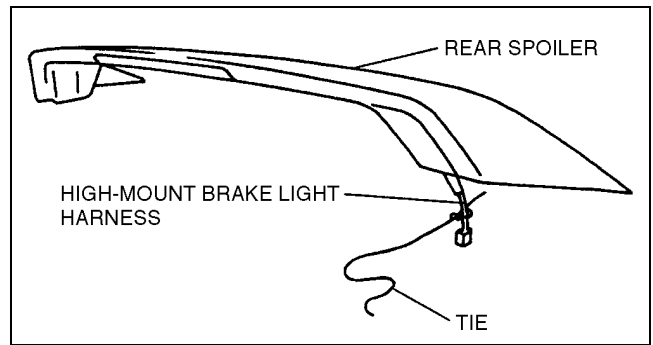

Y3U918WAJ

## LICENSE PLATE LIGHT REMOVAL/INSTALLATION

A3U091851270W01

1. Disconnect the negative battery cable.
2. Remove the rear finisher. (See 09-16-3 REAR FINISHER REMOVAL/INSTALLATION.)
3. Remove in the order indicated in the table.

1	License plate light (See 09-18-12 License Plate Light Removal Note)
2	Connector
3	Socket
4	License plate light bulb

4. Install in the reverse order of removal.

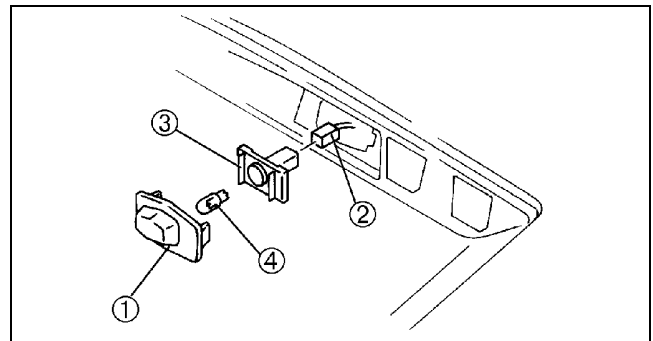

X3U918WA7

## License Plate Light Removal Note

1. Slide the license plate light to the arrow mark and remove it.

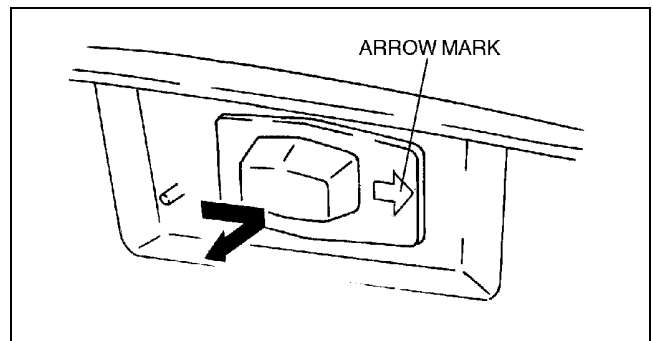

X3U918WA8

## COMBINATION SWITCH REMOVAL/INSTALLATION

A3U091866120W01

1. Disconnect the negative battery cable.
2. Remove the driver-side air bag module. (See 08-10-5 DRIVER-SIDE AIR BAG MODULE REMOVAL/INSTALLATION.)
3. Remove the steering wheel. (See 06-12-6 STEERING WHEEL AND COLUMN REMOVAL/INSTALLATION.)
4. Remove the column cover. (See 09-17-5 COLUMN COVER REMOVAL/INSTALLATION.)
5. Remove the clock spring. (See 08-10-9 CLOCK SPRING REMOVAL/INSTALLATION.)
6. Remove in the order indicated in the table.

1	Connector
2	Screw
3	Combination switch

7. Install in the reverse order of removal.

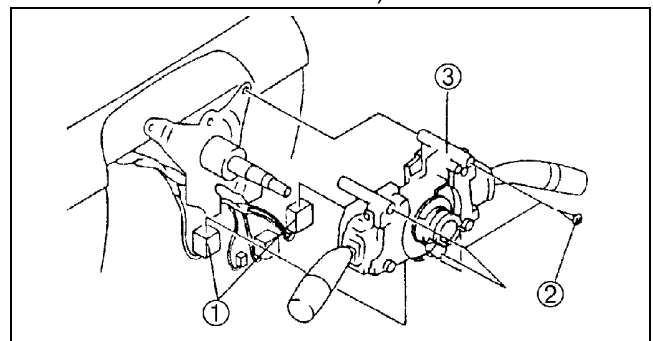

X3U918WA9

# LIGHTING SYSTEMS

## COMBINATION SWITCH DISASSEMBLY/ASSEMBLY

A3U091866120W02

1. Disassemble in the order indicated in the table.

1	Screw
2	Wiper lever
3	Light lever
4	Body

2. Assemble in the reverse order of disassembly.

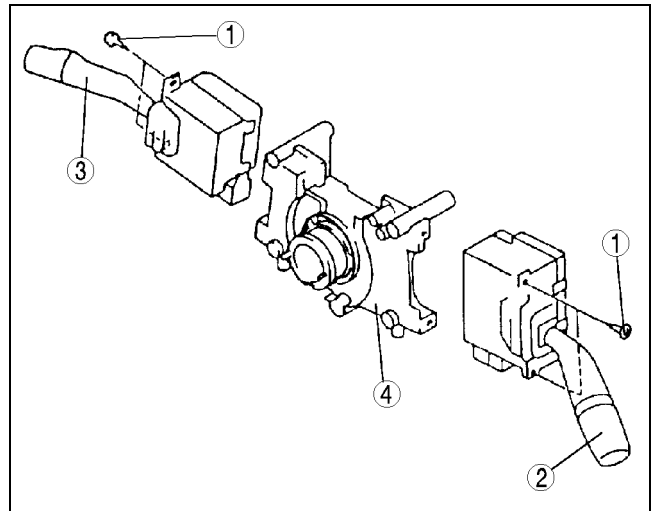

Z3U0918W003

## LIGHT SWITCH REMOVAL/INSTALLATION

A3U091866121W01

1. Disconnect the negative battery cable.
2. Remove the column cover. (See 09-17-5 COLUMN COVER REMOVAL/INSTALLATION.)
3. Remove in the order indicated in the table.

1	Connector
2	Screw
3	Light lever

4. Install in the reverse order of removal.

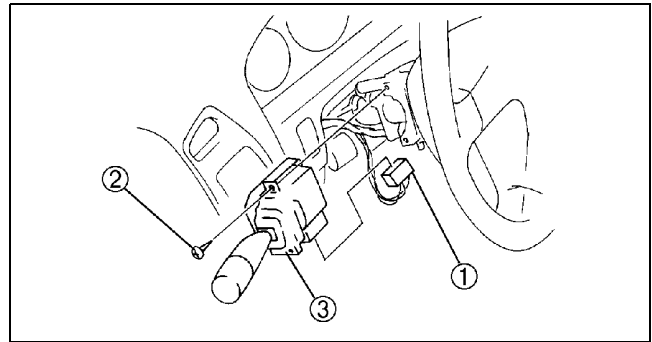

X3U918WAB

## LIGHT SWITCH INSPECTION

A3U091866121W02

### Headlight switch

1. Remove the light switch. (See 09-18-13 LIGHT SWITCH REMOVAL/INSTALLATION.)
2. Inspect for continuity between the light switch terminals using an ohmmeter.
  - If not as specified, replace the light switch.

○—○ : Continuity

Switch position			Terminal					
Light	Dimmer	Flash-to-pass	J	L	P	O	Q	R
OFF	-	Off						
		On			○—○	○—○		
TNS	-	Off		○—○				
		On		○—○	○—○	○—○		
Head-light	LO	Off	○—○	○—○				○
		On	○—○	○—○	○—○	○—○		
	HI	-	○—○	○—○	○—○			

Y3U918WAN

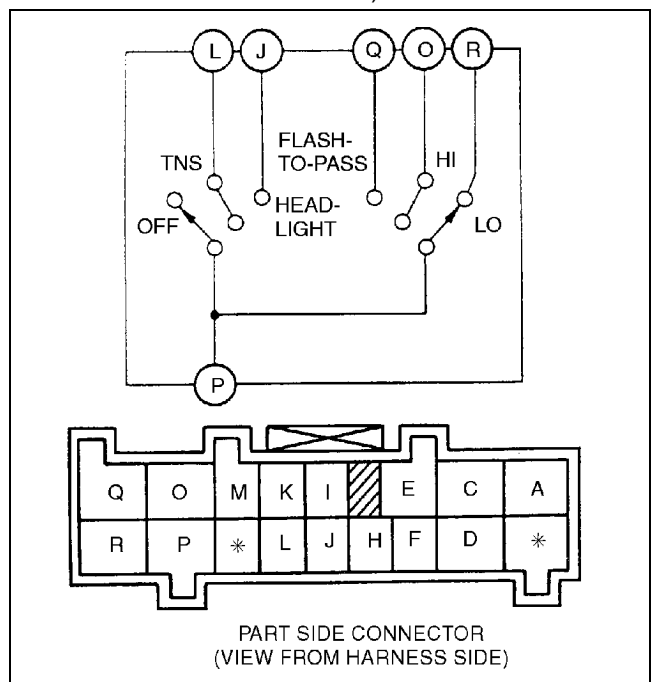

Y3U918WAO

# LIGHTING SYSTEMS

## Turn switch

1. Remove the light switch. (See 09-18-13 LIGHT SWITCH REMOVAL/INSTALLATION.)
2. Inspect for continuity between the light switch terminals using an ohmmeter.
  - If not as specified, replace the light switch.

○—○ : Continuity

Switch position	Terminal		
	C	A	E
Left	○—○		
Off			
Right			○—○

X3U918WBG

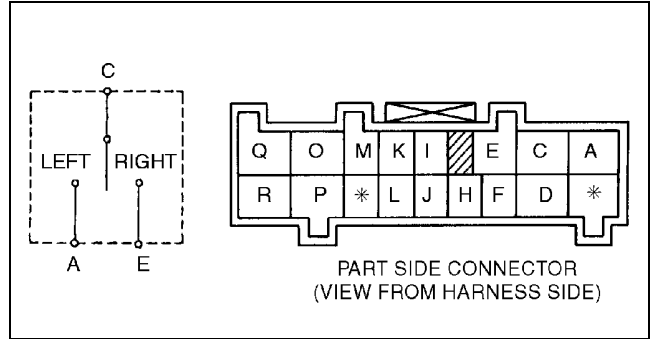

Y3U918WA1

## FRONT FOG LIGHT SWITCH REMOVAL/INSTALLATION

A3U091866402W01

1. Disconnect the negative battery cable.
2. Remove the left side side panel from the dashboard.
3. Compress the tabs of the front fog light switch and pull the switch out of the dashboard.
4. Disconnect the connector to remove the front fog light switch.
5. Install in the reverse order of removal.

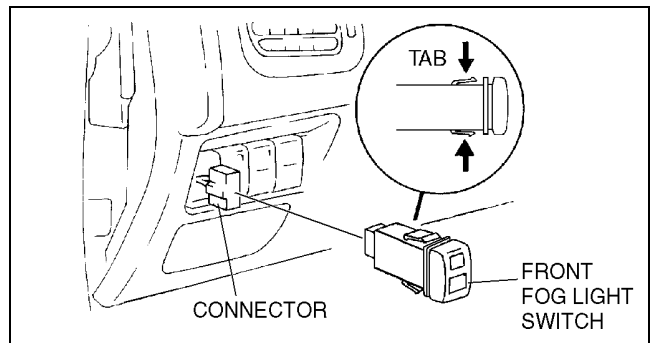

Z3U0918W009

## FRONT FOG LIGHT SWITCH INSPECTION

A3U091866402W02

1. Remove the front fog light switch. (See 09-18-14 FRONT FOG LIGHT SWITCH REMOVAL/INSTALLATION.)
2. Inspect for continuity between the front fog light switch terminals using an ohmmeter.
  - If not as specified, replace the front fog light switch.

○—○ : Continuity ○○ : Bulb

Switch position	Terminal			
	A	C	B	D
Off	○○			
On	○○		○—○	

Z3U0918W008

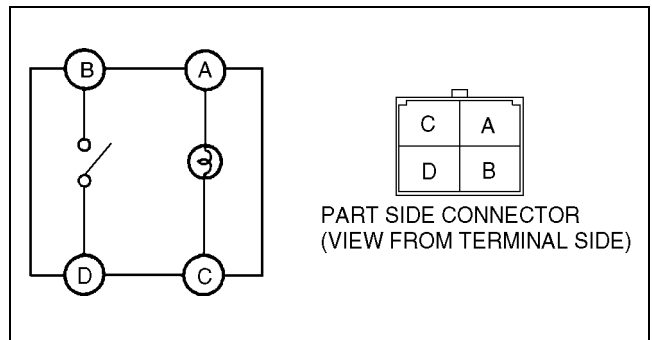

Z3U0918W007

## HAZARD WARNING SWITCH REMOVAL/INSTALLATION

A3U091866401W01

1. Disconnect the negative battery cable.
2. Remove the center panel. (See 09-17-4 CENTER PANEL REMOVAL/INSTALLATION.)
3. Grasp the tabs of the hazard warning switch and pull it forward to remove it.
4. Install in the reverse order of removal.

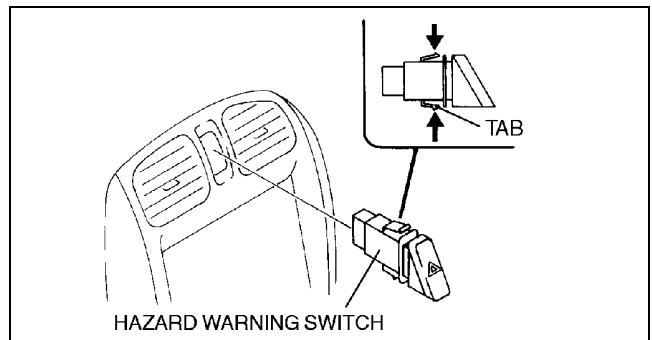

Y3U918WAP

# LIGHTING SYSTEMS

## HAZARD WARNING SWITCH INSPECTION

A3U091866401W02

1. Remove the hazard warning switch. (See 09-18-14 HAZARD WARNING SWITCH REMOVAL/INSTALLATION.)
2. Inspect for continuity between the hazard warning switch terminals using an ohmmeter.
  - If not as specified, replace the hazard warning switch.

○—○ : Continuity ○⊕○ : Bulb

Switch position	Terminal								
	F	D	B	A	C	I	K	H	J
OFF	○		○					○⊕○	○⊕○
ON		○	○	○	○	○	○	○⊕○	○⊕○

X3U918WBH

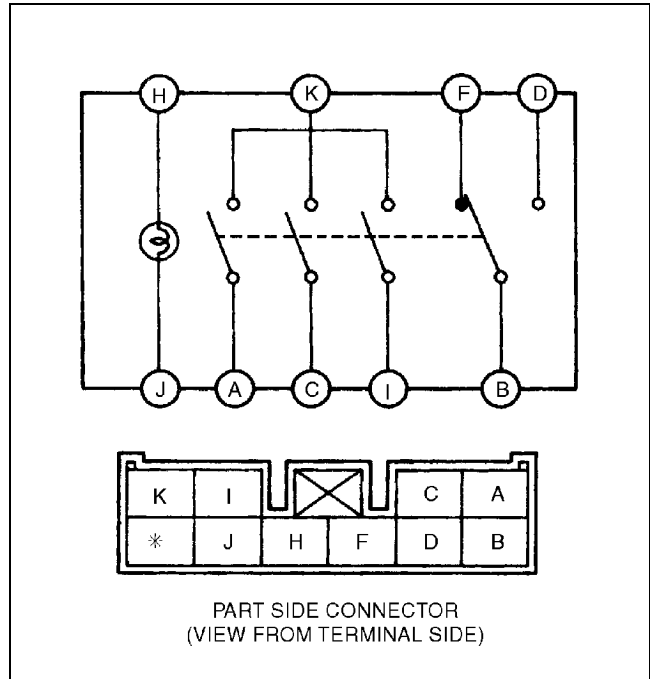

Y3U918WA2

## BACK-UP LIGHT SWITCH REMOVAL/INSTALLATION

A3U091817640W01

1. Disconnect the negative battery cable.
2. Remove in the order indicated in the table.

1	Connector
2	Back-up light switch

3. Install in the reverse order of removal.

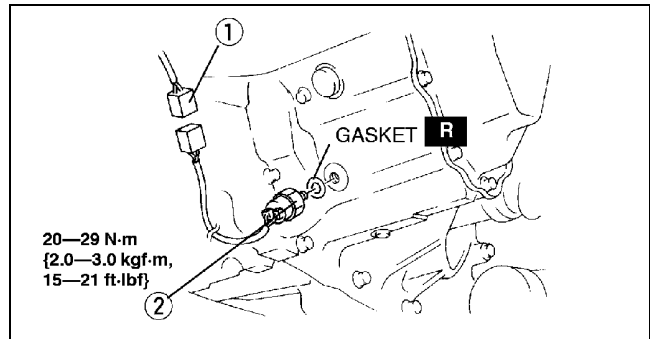

X3U918WAG

## BACK-UP LIGHT SWITCH INSPECTION

A3U091817640W02

1. Disconnect the back-up light switch connector.
2. Inspect for continuity between the back-up light switch terminals using an ohmmeter.
  - If not as specified, replace the back-up light switch.

○—○ : Continuity

Shift lever position	Terminal	
	A	B
Reverse	○—○	○—○
Other		

X3U918WBJ

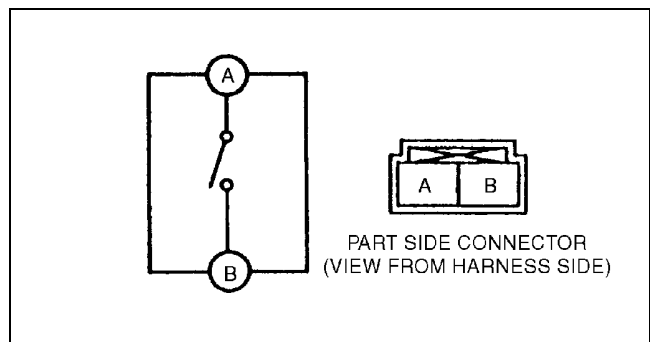

Y3U918WA3

# LIGHTING SYSTEMS

## FLASHER CONTROL MODULE REMOVAL/INSTALLATION

A3U091866830W01

**Note**

- Because the lock section of the control module is damaged easily, do not remove the control module from the bracket unless replacement is necessary. Always perform an inspection of the flasher control module before removal.

1. Disconnect the negative battery cable.
2. Remove the bracket.
3. Disconnect the flasher control module connector.
4. Remove the flasher control module by prying the lock section of the upper part with a flathead screwdriver.
5. Install in the reverse order of removal.

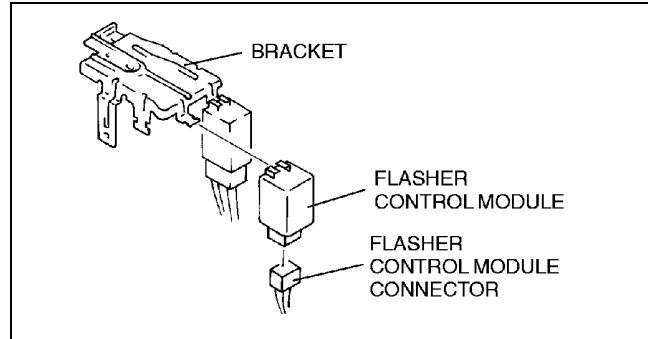

X3U918WJA1

## FLASHER CONTROL MODULE INSPECTION

A3U091866830W02

1. Remove the bracket and pull it toward you.
2. Measure the voltage at the flasher control module terminals as indicated below.
3. Disconnect the flasher control module connector before inspecting for continuity at terminal F.
  - If not as specified, inspect the parts listed under "Action."
  - If the parts and wiring harnesses are okay but the system still does not work properly, replace the flasher control module.

### Terminal Voltage List (Reference)

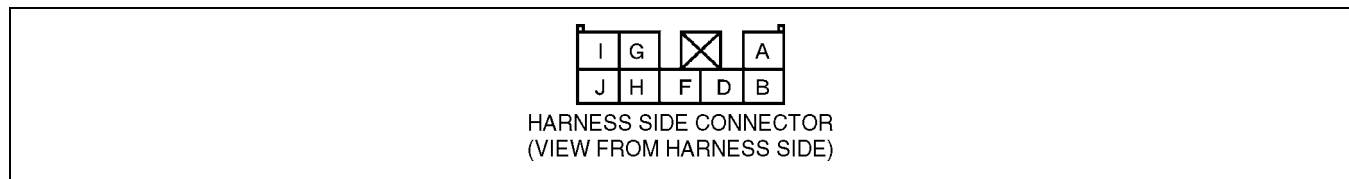

ZLU918WA6

Terminal	Signal	Connected to	Test condition	Voltage (V)/ Continuity	Action
A	Power supply	HAZARD 15 A fuse	Under any condition	B+	<ul style="list-style-type: none"> <li>• Inspect HAZARD 15 A fuse</li> <li>• Inspect related harness</li> </ul>
B	—	—	—	—	—
D	Turn signal flasher (LH)	Turn signal light (LH)	Turn signal light (LH) flashes.	Alternates below 1.0 and B+	<ul style="list-style-type: none"> <li>• Inspect turn signal light (LH)</li> <li>• Inspect related harness</li> </ul>
			Hazard warning switch at on position.		
			Other	Below 1.0	
F	Flasher control module ground	GND	Constant: inspect for continuity to ground.	Yes	<ul style="list-style-type: none"> <li>• Inspect GND</li> </ul>
G	Turn signal flasher (RH)	Turn signal light (RH)	Turn signal light (RH) flashes.	Alternates below 1.0 and B+	<ul style="list-style-type: none"> <li>• Inspect turn signal light (RH)</li> <li>• Inspect related harness</li> </ul>
			Hazard warning switch at on position.		
			Other	Below 1.0	
H	Hazard warning on	Hazard warning switch	Hazard warning switch at on position.	Below 1.0	<ul style="list-style-type: none"> <li>• Inspect hazard warning switch (See 09-18-15 HAZARD WARNING SWITCH INSPECTION)</li> <li>• Inspect related harness</li> </ul>
			Hazard warning switch at off position.	B+	
I	Turn switch on/off (RH)	Combination switch (light switch)	Ignition switch is at ON and turn switch (RH) on.	B+	<ul style="list-style-type: none"> <li>• Inspect light switch (See 09-18-13 LIGHT SWITCH INSPECTION)</li> <li>• Inspect TURN 10 A fuse</li> <li>• Inspect related harness</li> </ul>
			Other	Below 1.0	
J	Turn switch on/off (LH)	Combination switch (light switch)	Ignition switch is at ON and turn switch (LH) on.	B+	<ul style="list-style-type: none"> <li>• Inspect light switch (See 09-18-13 LIGHT SWITCH INSPECTION)</li> <li>• Inspect TURN 10 A fuse</li> <li>• Inspect related harness</li> </ul>
			Other	Below 1.0	

# LIGHTING SYSTEMS

## DAYTIME RUNNING LIGHT (DRL) SYSTEM WIRING DIAGRAM

A3U091867750W01

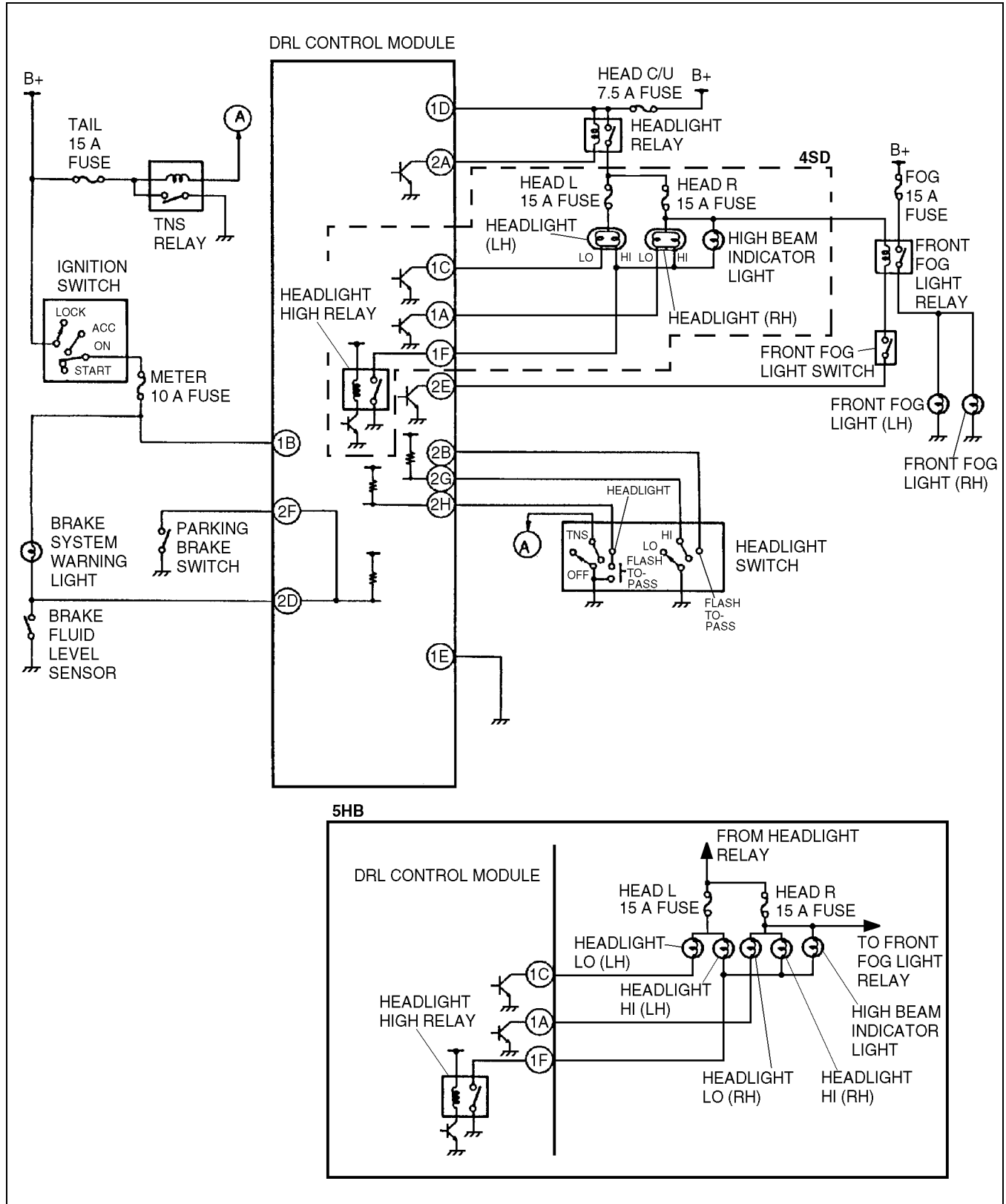

A3U0918W105



# LIGHTING SYSTEMS

## DRL CONTROL MODULE REMOVAL/INSTALLATION (CANADA)

A3U091867750W02

### Note

- Because the lock section of the control module is damaged easily, do not remove the control module from the bracket unless replacement is necessary. Always perform an inspection of the DRL control module before removal.

- Remove the negative battery cable.
- Remove the bracket.
- Disconnect the DRL control module connector.
- Remove the DRL control module by prying the lock section of the side part with a flathead screwdriver.
- Install in the reverse order of removal.

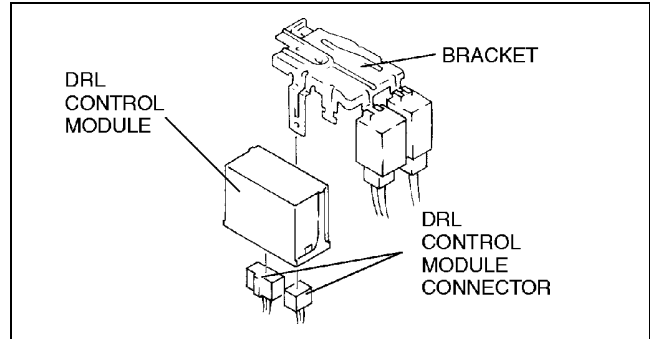

X3U918WAL

## DRL CONTROL MODULE INSPECTION (CANADA)

A3U091867750W03

- Remove the bracket and pull it toward you.
- Measure the voltage at the DRL control module terminals as indicated below.
- Disconnect the DRL control module connector before inspecting for continuity at terminal 1E.
  - If not as specified, inspect the parts listed under "Action."
  - If the parts and wiring harnesses are okay but the system still does not work properly, replace the DRL control module.

### Terminal Voltage List (Reference)

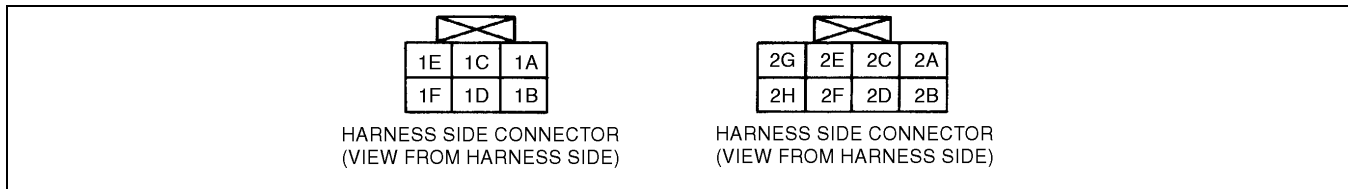

Y3U918WA7

Terminal	Signal	Connected to	Test condition		Voltage (V)/ Continuity	Action
			Headlight switch at headlight position	Dimmer switch at high beam position		
1A	RH headlight operation (low beam)	RH headlight (low beam)	Headlight switch at headlight position	4SD	B+	<ul style="list-style-type: none"> <li>Inspect HEAD R 15 A fuse</li> <li>Inspect RH headlight</li> <li>Inspect related harness</li> </ul>
				5HB	Below 1.5	
			Headlight switch at OFF or TNS position		Below 1.5	
1B	IG1	METER 10 A fuse	Ignition switch at ON position		B+	<ul style="list-style-type: none"> <li>Inspect METER 10 A fuse</li> <li>Inspect related harness</li> </ul>
			Ignition switch at LOCK or ACC position		Below 1.0	
1C	LH headlight operation (low beam)	LH headlight (low beam)	Headlight switch at headlight position	Dimmer switch at high beam position	4SD	<ul style="list-style-type: none"> <li>Inspect HEAD L 15 A fuse</li> <li>Inspect LH headlight</li> <li>Inspect related harness</li> </ul>
				5HB	Below 1.5	
			Dimmer switch at low beam position		Below 1.5	
Headlight switch at OFF or TNS position		Below 1.5				
1D	Power supply	HEAD C/U 7.5 A fuse	Under any condition		B+	<ul style="list-style-type: none"> <li>Inspect HEAD C/U 7.5 A fuse</li> <li>Inspect related harness</li> </ul>
1E	DRL control module ground	GND	Constant: inspect for continuity to ground		Yes	<ul style="list-style-type: none"> <li>Inspect related harness</li> </ul>

## LIGHTING SYSTEMS

Terminal	Signal	Connected to	Test condition		Voltage (V)/ Continuity	Action
1F	Headlight operation (high beam)	Headlight (high beam)	Headlight switch at headlight position	Dimmer switch at high beam position	Below 1.0	<ul style="list-style-type: none"> <li>Inspect headlight</li> <li>Inspect HEAD R 15 A fuse</li> <li>Inspect HEAD L 15 A fuse</li> <li>Inspect related harness</li> </ul>
				Dimmer switch at low beam position	B+	
			Headlight switch at OFF or TNS position		Below 1.0	
2A	Headlight relay operation	Headlight relay	Headlight switch at headlight position		Below 1.0	<ul style="list-style-type: none"> <li>Inspect headlight relay (See 09-21-5 RELAY INSPECTION)</li> <li>Inspect related harness</li> </ul>
			Headlight switch at OFF or TNS position		B+	
2B	Flash-to-pass on/off	Headlight switch	Flash-to-pass activated		Below 1.0	<ul style="list-style-type: none"> <li>Inspect combination switch</li> <li>Inspect related harness</li> </ul>
			Flash-to-pass not activated		B+	
2C	—	—	—		—	—
2D	Brake system warning light operation	<ul style="list-style-type: none"> <li>Brake system warning light</li> <li>Brake fluid level sensor</li> </ul>	Ignition switch at ON position	Brake fluid level is below MIN.	Below 1.0	<ul style="list-style-type: none"> <li>Inspect METER 10 A fuse</li> <li>Inspect instrument cluster (See 09-22-4 INSTRUMENT CLUSTER INSPECTION)</li> <li>Inspect brake fluid level sensor (See 04-11-9 FLUID LEVEL SENSOR INSPECTION)</li> <li>Inspect related harness</li> </ul>
				Brake fluid level is above MIN.	B+	
			Ignition switch at LOCK or ACC position		Below 1.0	
2E	Front fog light relay operation	Front fog light switch	<ul style="list-style-type: none"> <li>Headlight switch at headlight position</li> <li>Front fog light switch on</li> </ul>	Dimmer switch at high beam position	B+	<ul style="list-style-type: none"> <li>Inspect front fog light relay (See 09-21-5 RELAY INSPECTION)</li> <li>Inspect related harness</li> </ul>
				Dimmer switch at low beam position	Below 1.5	
2F	Parking brake lever pulled/released	Parking brake switch	Parking brake lever pulled		Below 1.0	<ul style="list-style-type: none"> <li>Inspect parking brake switch</li> <li>Inspect related harness</li> </ul>
			Parking brake lever released		B+	
2G	High beam on/off	Headlight switch	Dimmer switch at high beam position		Below 1.0	<ul style="list-style-type: none"> <li>Inspect combination switch</li> <li>Inspect related harness</li> </ul>
			Dimmer switch at low beam position		B+	
2H	Headlight switch on/off	Headlight switch	Headlight switch at headlight position		Below 1.0	<ul style="list-style-type: none"> <li>Inspect combination switch</li> <li>Inspect related harness</li> </ul>
			Headlight switch at OFF or TNS position		B+	

# LIGHTING SYSTEMS

## INTERIOR AND MAP LIGHT REMOVAL/INSTALLATION

A3U091851310W01

1. Disconnect the negative battery cable.
2. Remove in the order indicated in the table.

1	Lens (See 09-18-20 Lens Removal Note)
2	Interior light bulb
3	Map light bulb
4	Screw
5	Interior and map light
6	Connector

3. Install in the reverse order of removal.

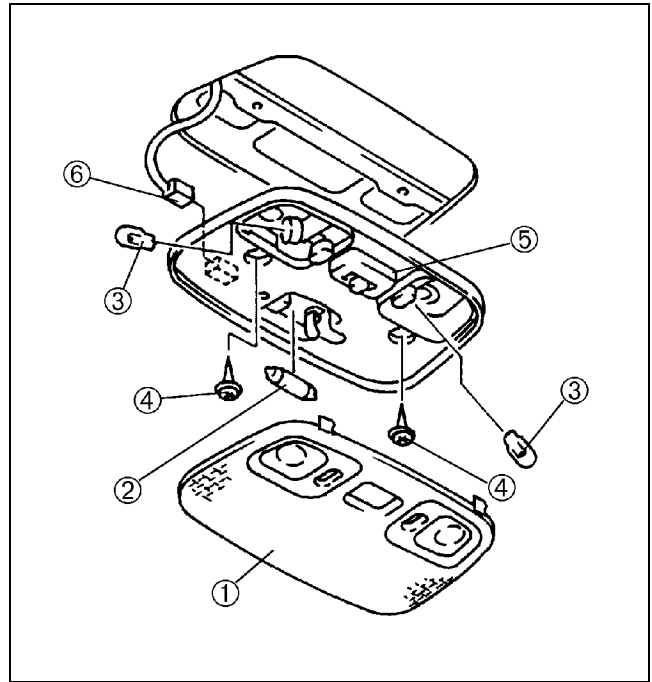

X3U918WAW

### Lens Removal Note

1. Insert a tape-wrapped, flathead screwdriver into the service hole.
2. Twist the flathead screwdriver in the direction indicated by the arrow to remove the lens.

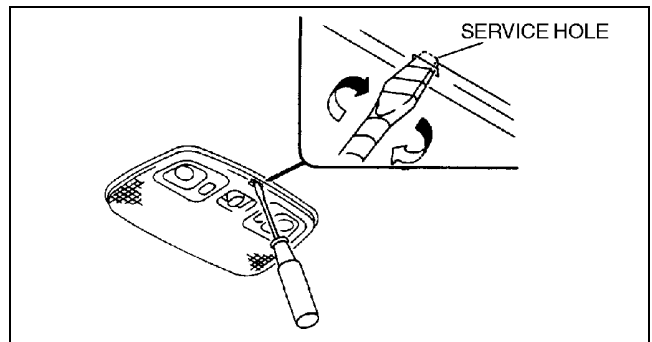

X3U918WAX

## INTERIOR AND MAP LIGHT INSPECTION

A3U091851310W02

1. Remove the interior and map light. (See 09-18-20 INTERIOR AND MAP LIGHT REMOVAL/INSTALLATION.)
2. Inspect for continuity between the interior and map light terminals using an ohmmeter.
  - If not as specified, replace the interior and map light.

○—(⊕)—○ : Bulb

Switch position	Terminal		
	A	B	Body GND
Map light switch	ON	○—(⊕)—○	
	OFF		○—(⊕)—○
Interior light switch	ON		○—(⊕)—○
	DOOR	○—(⊕)—○	
	OFF		

Y3U918WAK

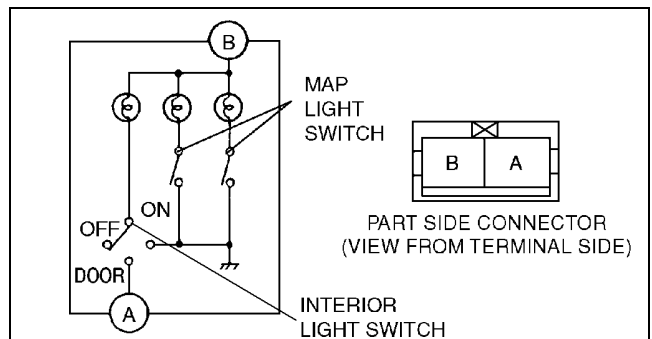

Z3U0918W004

# LIGHTING SYSTEMS

## MAP LIGHT REMOVAL/INSTALLATION

A3U091851310W03

1. Disconnect the negative battery cable.
2. Remove in the order indicated in the table.

1	Lens (See 09-18-21 Lens Removal Note)
2	Map light bulb
3	Map light
4	Connector

3. Install in the reverse order of removal.

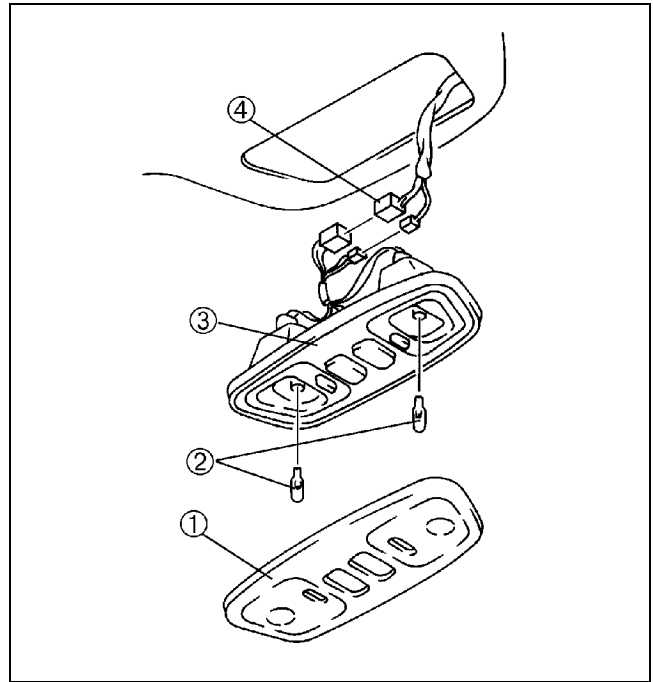

X3U918WAZ

### Lens Removal Note

1. Insert a tape-wrapped, flathead screwdriver into the service hole.
2. Twist the flathead screwdriver in the direction indicated by the arrow to remove the lens.

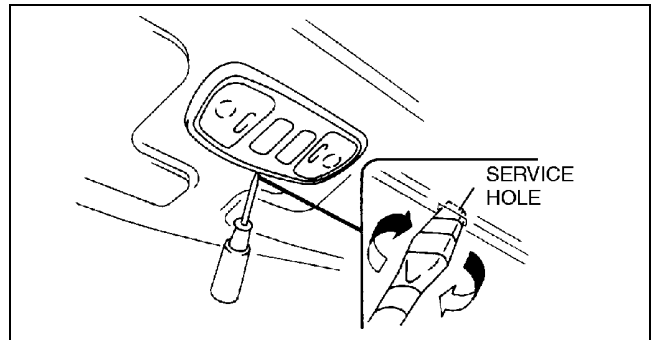

X3U918WB0

09-18

## MAP LIGHT INSPECTION

A3U091851310W04

1. Remove the map light. (See 09-18-21 MAP LIGHT REMOVAL/INSTALLATION.)
2. Inspect for continuity between the map light terminals using an ohmmeter.
  - If not as specified, replace the map light.

○ ⊕ ○ : Bulb

Switch position	Terminal	
	1A	2B
ON	○ — ⊕ — ○	
OFF		

X3U918WBN

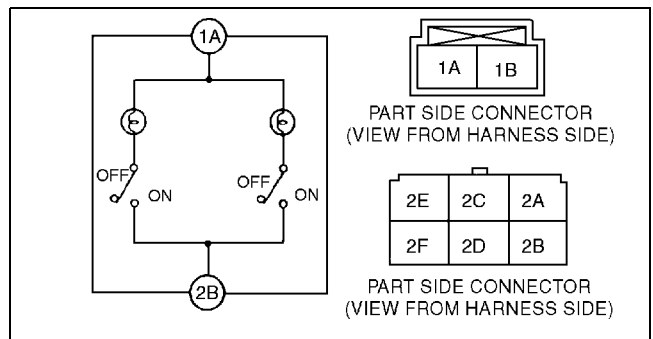

Y3U918WAB

# LIGHTING SYSTEMS

A3U091869970W01

## INTERIOR LIGHT REMOVAL/INSTALLATION

1. Disconnect the negative battery cable.
2. Remove in the order indicated in the table.

1	Lens (See 09-18-22 Lens Removal Note)
2	Interior light bulb
3	Screw
4	Interior light
5	Connector

3. Install in the reverse order of removal.

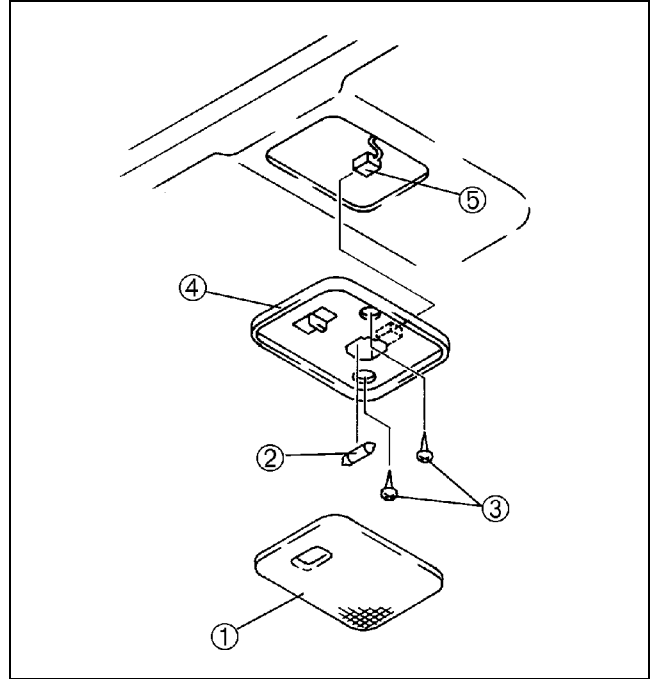

X3U918WB2

### Lens Removal Note

1. Insert a tape-wrapped, flathead screwdriver into the service hole.
2. Twist the flathead screwdriver in the direction indicated by the arrow to remove the lens.

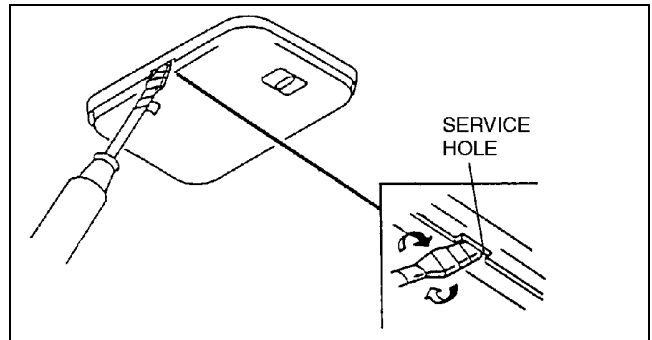

X3U918WB3

## INTERIOR LIGHT INSPECTION

A3U091869970W02

1. Remove the interior light. (See 09-18-22 INTERIOR LIGHT REMOVAL/INSTALLATION.)
2. Inspect for continuity between the interior light terminals using an ohmmeter.
  - If not as specified, replace the interior light.

○ ⊕ ○ : Bulb

Switch position	Terminal		
	A	B	Body GND
ON		○ ⊕ ○	○ ⊕ ○
DOOR	○ ⊕ ○		
OFF			

X3U918WBP

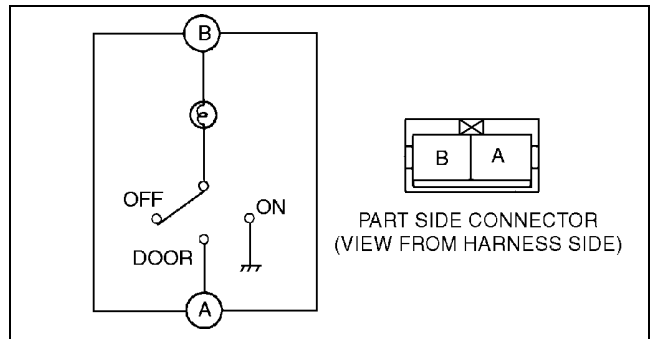

Z3U0918W005

# LIGHTING SYSTEMS

## TRUNK COMPARTMENT LIGHT BULB REMOVAL/INSTALLATION

A3U091851440W01

1. Disconnect the negative battery cable.
2. Pinch the sides of the lens and pull down to remove.
3. Remove the bulb.
4. Install in the reverse order of removal.

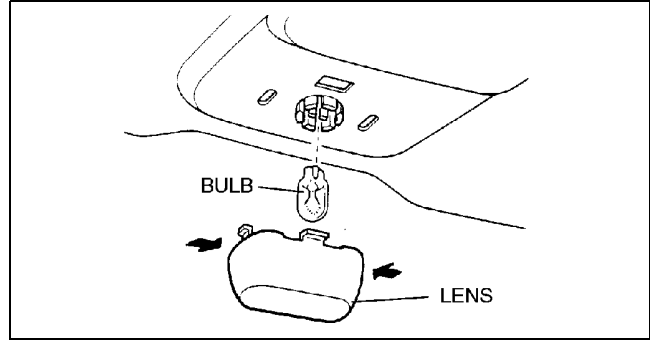

X3U918WB5

## TRUNK COMPARTMENT LIGHT SWITCH INSPECTION

A3U091851440W02

### Note

- Trunk compartment light switch has a built-in trunk lid lock.

1. Disconnect the trunk compartment light switch connector.
2. Inspect for continuity between the trunk compartment light switch terminal and a body ground using an ohmmeter.
  - If not as specified, replace the trunk lid lock.

○—○ : Continuity

Switch position	Terminal	
	A	B
Locked (trunk lid closed)		
Unlocked (trunk lid opened)	○—○	○—○

X3U918WBQ

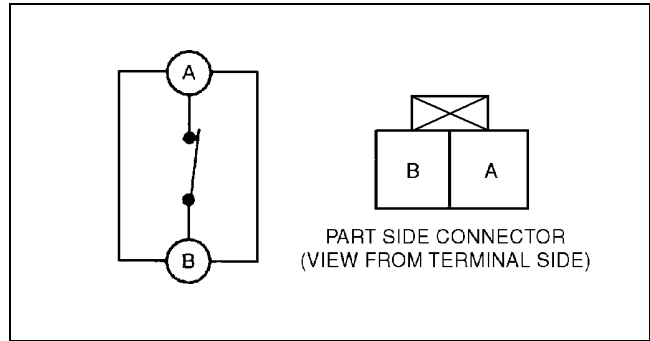

Y3U918WAD

09-18

## CARGO COMPARTMENT LIGHT REMOVAL/INSTALLATION

A3U091851441W01

1. Disconnect the negative battery cable.
2. Pinch the sides of the lens and pull to remove.
3. Remove the cargo compartment light bulb.
4. Push the area indicated by the arrow and pull to remove the cargo compartment light.
5. Disconnect the connectors.
6. Install in the reverse order of removal.

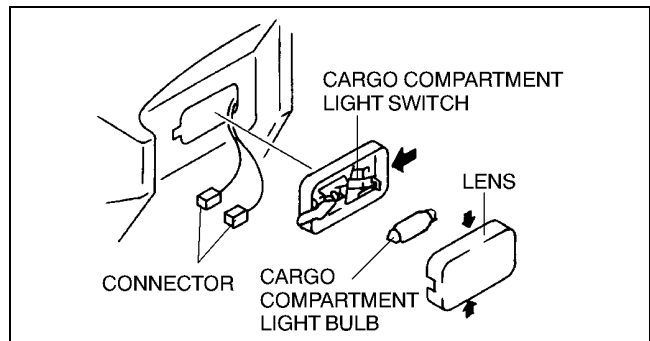

A3U0918W005

# LIGHTING SYSTEMS

## CARGO COMPARTMENT LIGHT INSPECTION

A3U091851441W02

1. Remove the cargo compartment light. (See 09–18–23 CARGO COMPARTMENT LIGHT REMOVAL/INSTALLATION.)
2. Inspect for continuity between the cargo compartment light terminals using an ohmmeter.
  - If not as specified, replace the cargo compartment light.

○—○ : Bulb

Switch position	Terminal	
	A	B
ON	○—○	
OFF		

YMU918WB7

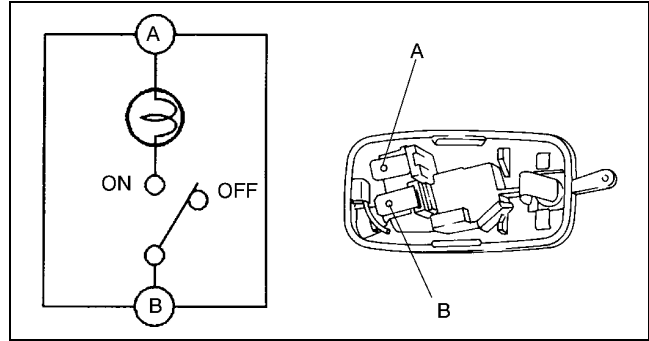

A3U0918W007

## CARGO COMPARTMENT LIGHT SWITCH INSPECTION

A3U091851442W01

1. Remove the liftgate trim. (See 09–17–16 LIFTGATE TRIM REMOVAL/INSTALLATION.)
2. Disconnect the cargo compartment light switch connector.
3. Inspect for continuity between the cargo compartment light switch terminals using an ohmmeter.
  - If not as specified, replace the liftgate lock.

○—○ : Continuity

Switch position	Terminal	
	A	B
On (liftgate open)	○—○	○—○
Off (liftgate closed)		

YMU918WB9

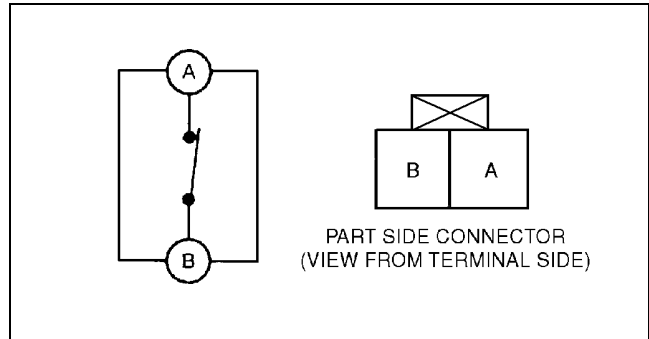

Y3U918WAD

## IGNITION KEY ILLUMINATION BULB REMOVAL/INSTALLATION

A3U091860231W01

1. Disconnect the negative battery cable.
2. Remove the column cover.
3. Remove the ignition key illumination bulb.
4. Install in the reverse order of removal.

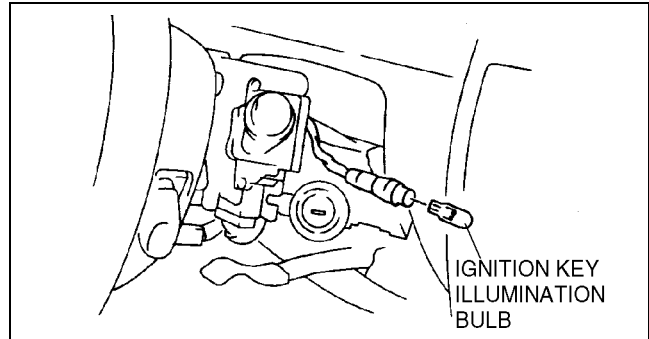

Z3U0918W015

## DOOR SWITCH REMOVAL/INSTALLATION

A3U091866540W01

### Front

1. Disconnect the negative battery cable.
2. Remove in the order indicated in the table.

1	Screw
2	Connector
3	Door switch

3. Install in the reverse order of removal.

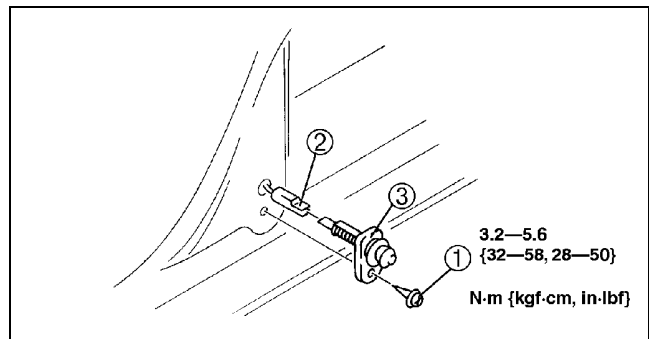

Y3U918WAE

# LIGHTING SYSTEMS

## Rear

1. Disconnect the negative battery cable.
2. Remove in the order indicated in the table.

1	Screw
2	Connector
3	Door switch

3. Install in the reverse order of removal.

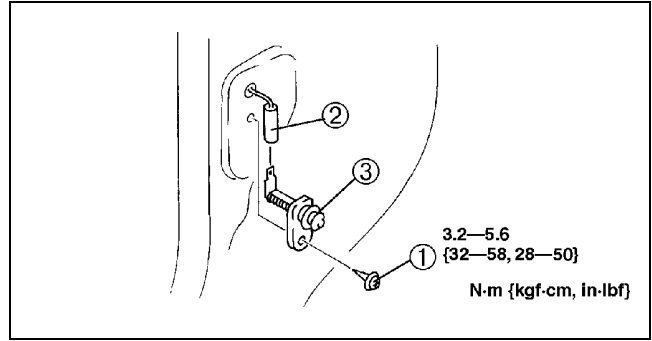

Y3U918WAF

## DOOR SWITCH INSPECTION

1. Remove the door switch. (See 09-18-24 DOOR SWITCH REMOVAL/INSTALLATION.)
2. Inspect for continuity between the door switch terminal and a body ground using an ohmmeter.
  - If not as specified, replace the door switch.

A3U091866540W02

○—○ : Continuity

Switch position	Terminal	
	A	Body GND
Pressed	○—○	
Released		○—○

X3U918WBR

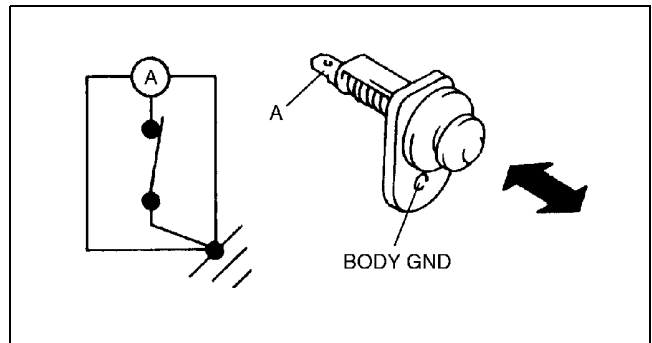

X3U918WB9

09-18

## PANEL LIGHT CONTROL SWITCH REMOVAL/INSTALLATION

1. Disconnect the negative battery cable.
2. Remove the driver-side side panel.
3. Remove in the order indicated in the table.

A3U091866600W01

1	Panel light control switch (See 09-18-25 Panel Light Control Switch Removal Note)
2	Connector

4. Install in the reverse order of removal.

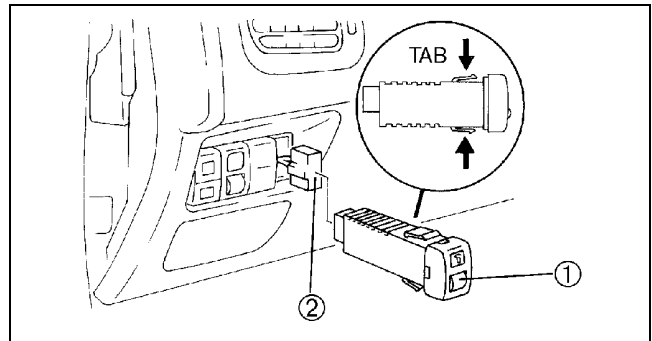

Y3U918WAS

### Panel Light Control Switch Removal Note

1. Insert your hand into the hole in the driver-side side panel, grasp the tabs of the panel light control switch and pull it forward to remove.



# LIGHTING SYSTEMS

## PANEL LIGHT CONTROL SWITCH INSPECTION

A3U091866600W02

1. Remove the panel light control switch. (See 09–18–25 PANEL LIGHT CONTROL SWITCH REMOVAL/INSTALLATION.)
2. Connect the negative battery cable.
3. Connect the connector to the panel light control switch.
4. Measure the voltage at the panel light control switch as indicated below.
5. Disconnect the panel light control switch connector before inspecting for continuity at terminal D.
  - If not as specified, inspect the parts listed under “Action.”
  - If the parts and wiring harnesses are okay but the system still does not work properly, replace the panel light control switch.

### Terminal Voltage List (Reference)

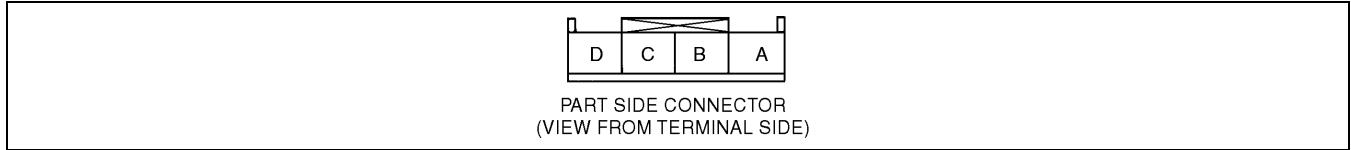

Y3U918WAG

Terminal	Signal	Connected to	Test condition	Voltage (V)/Continuity	Action
A	—	—	—	—	—
B	TNS	TNS relay	Headlight switch at TNS or headlight position	B+	<ul style="list-style-type: none"> <li>• Inspect TNS relay</li> <li>• Inspect combination switch</li> <li>• Inspect TAIL 15 A fuse</li> <li>• Inspect related harness</li> </ul>
			Other	Below 1.0	
C	Illumination	Each illumination	Inspect using an oscilloscope (See 09–18–26 Terminal C inspection)	—	<ul style="list-style-type: none"> <li>• Inspect each illumination</li> <li>• Inspect related harness</li> </ul>
D	Ground	GND	Constant: inspect for continuity to ground	Yes	<ul style="list-style-type: none"> <li>• Inspect GND</li> </ul>

### Terminal C inspection

1. Measure the wave pattern of the C terminal on the panel light control switch using an oscilloscope.
2. Set the headlight switch to either the TNS or headlight position.
3. Set the panel light control switch to the brightest position.

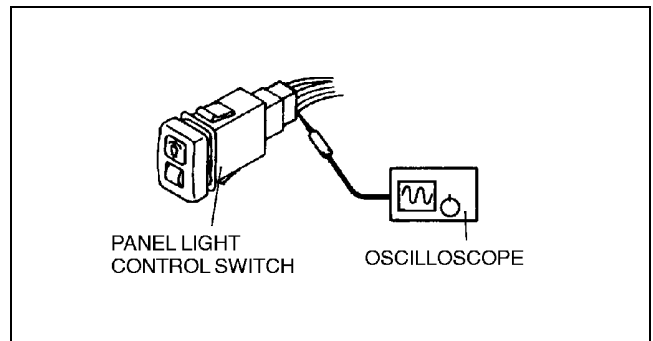

X3U918WBC

4. Verify that the pattern on the screen is as shown in the figure.



X3U918WBD

## LIGHTING SYSTEMS

5. Verify that the pattern on the screen matches the pattern shown in the figure as the panel light control switch is gradually turned to the darkest position.

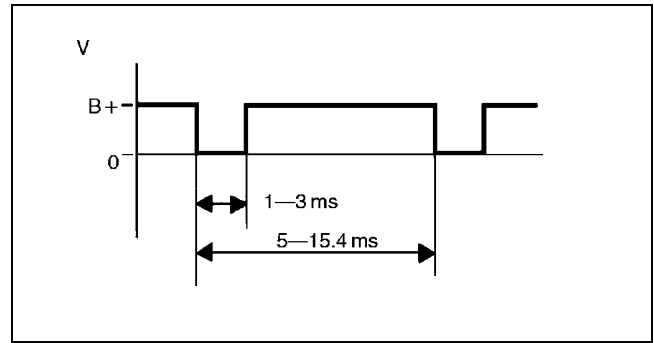

X3U918WBE

## **09-19 WIPER/WASHER SYSTEM**

<b>LOCATION INDEX</b> .....	<b>09-19-2</b>	<b>WINDSHIELD WASHER NOZZLE</b>	
Windshield Wiper and Washer System	09-19-2	<b>ADJUSTMENT</b> .....	09-19-10
Rear Wiper and Washer System	09-19-3	<b>WINDSHIELD WASHER NOZZLE</b>	
<b>WIPER/WASHER SYSTEMS</b>		<b>CLEANING</b> .....	09-19-11
<b>WIRING DIAGRAM</b> .....	09-19-4	<b>WINDSHIELD WASHER NOZZLE</b>	
<b>WINDSHIELD WIPER ARM AND BLADE</b>		<b>REMOVAL</b> .....	09-19-11
<b>ADJUSTMENT</b> .....	09-19-5	<b>WINDSHIELD WASHER NOZZLE</b>	
<b>WINDSHIELD WIPER ARM AND BLADE</b>		<b>INSTALLATION</b> .....	09-19-11
<b>REMOVAL/INSTALLATION</b> .....	09-19-5	<b>WINDSHIELD WASHER HOSE</b>	
Windshield Wiper Arm		<b>REMOVAL/INSTALLATION</b> .....	09-19-11
Installation Note	09-19-5	<b>REAR WIPER ARM AND BLADE</b>	
<b>WINDSHIELD WIPER LINK</b>		<b>ADJUSTMENT</b> .....	09-19-12
<b>REMOVAL/INSTALLATION</b> .....	09-19-5	<b>REAR WIPER ARM AND BLADE</b>	
<b>WINDSHIELD WIPER MOTOR</b>		<b>REMOVAL/INSTALLATION</b> .....	09-19-12
<b>REMOVAL/INSTALLATION</b> .....	09-19-6	Rear Wiper Arm Installation Note	09-19-12
<b>WINDSHIELD WIPER MOTOR</b>		<b>REAR WIPER MOTOR</b>	
<b>INSPECTION</b> .....	09-19-6	<b>REMOVAL/INSTALLATION</b> .....	09-19-12
<b>WASHER TANK</b>		<b>REAR WIPER MOTOR INSPECTION</b> ..	09-19-13
<b>REMOVAL/INSTALLATION</b> .....	09-19-7	<b>REAR WASHER MOTOR</b>	
<b>WINDSHIELD WASHER MOTOR</b>		<b>REMOVAL/INSTALLATION</b> .....	09-19-14
<b>REMOVAL/INSTALLATION</b> .....	09-19-7	<b>REAR WASHER MOTOR INSPECTION</b> .	09-19-14
<b>WINDSHIELD WASHER MOTOR</b>		<b>REAR WASHER NOZZLE</b>	
<b>INSPECTION</b> .....	09-19-8	<b>REMOVAL/INSTALLATION</b> .....	09-19-14
<b>WASHER FLUID-LEVEL SENSOR</b>		<b>REAR WASHER NOZZLE</b>	
<b>REMOVAL/INSTALLATION</b> .....	09-19-8	<b>ADJUSTMENT</b> .....	09-19-15
<b>WASHER FLUID-LEVEL SENSOR</b>		<b>REAR WASHER NOZZLE CLEANING</b> ..	09-19-15
<b>INSPECTION</b> .....	09-19-8	<b>REAR WASHER HOSE</b>	
<b>WIPER AND WASHER SWITCH</b>		<b>REMOVAL/INSTALLATION</b> .....	09-19-15
<b>REMOVAL/INSTALLATION</b> .....	09-19-9	<b>INTERMITTENT REAR WIPER RELAY</b>	
<b>WIPER AND WASHER SWITCH</b>		<b>REMOVAL/INSTALLATION</b> .....	09-19-16
<b>INSPECTION</b> .....	09-19-9	<b>INTERMITTENT REAR WIPER RELAY</b>	
Windshield Wiper and Washer	09-19-9	<b>INSPECTION</b> .....	09-19-16
Rear Wiper and Washer	09-19-10	Terminal Voltage Table (Reference)	09-19-16

# WIPER/WASHER SYSTEM

## LOCATION INDEX

A3U091901063W01

### Windshield Wiper and Washer System

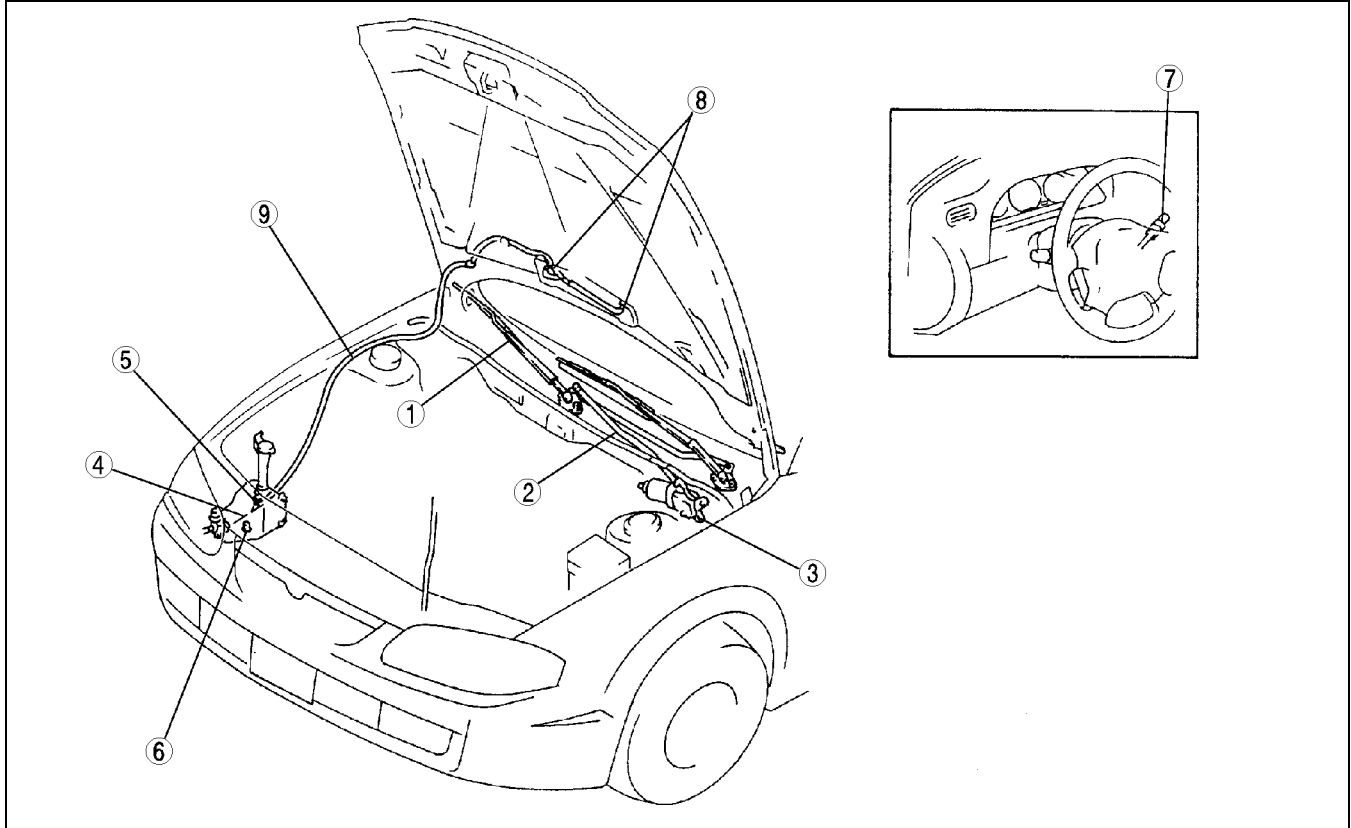

Z3U0919W003

1	Windshield wiper arm and blade (See 09-19-5 WINDSHIELD WIPER ARM AND BLADE ADJUSTMENT) (See 09-19-5 WINDSHIELD WIPER ARM AND BLADE REMOVAL/INSTALLATION)
2	Windshield wiper link (See 09-19-5 WINDSHIELD WIPER LINK REMOVAL/INSTALLATION)
3	Windshield wiper motor (See 09-19-6 WINDSHIELD WIPER MOTOR REMOVAL/INSTALLATION) (See 09-19-6 WINDSHIELD WIPER MOTOR INSPECTION)
4	Washer tank (See 09-19-7 WASHER TANK REMOVAL/INSTALLATION)
5	Windshield washer motor (See 09-19-7 WINDSHIELD WASHER MOTOR REMOVAL/INSTALLATION) (See 09-19-8 WINDSHIELD WASHER MOTOR INSPECTION)

6	Washer fluid-level sensor (See 09-19-8 WASHER FLUID-LEVEL SENSOR REMOVAL/INSTALLATION) (See 09-19-8 WASHER FLUID-LEVEL SENSOR INSPECTION)
7	Wiper and washer switch (See 09-19-9 WIPER AND WASHER SWITCH REMOVAL/INSTALLATION) (See 09-19-9 WIPER AND WASHER SWITCH INSPECTION)
8	Windshield washer nozzle (See 09-19-10 WINDSHIELD WASHER NOZZLE ADJUSTMENT) (See 09-19-11 WINDSHIELD WASHER NOZZLE CLEANING) (See 09-19-11 WINDSHIELD WASHER NOZZLE REMOVAL) (See 09-19-11 WINDSHIELD WASHER NOZZLE INSTALLATION)
9	Windshield washer hose (See 09-19-11 WINDSHIELD WASHER HOSE REMOVAL/INSTALLATION)

# WIPER/WASHER SYSTEM

## Rear Wiper and Washer System

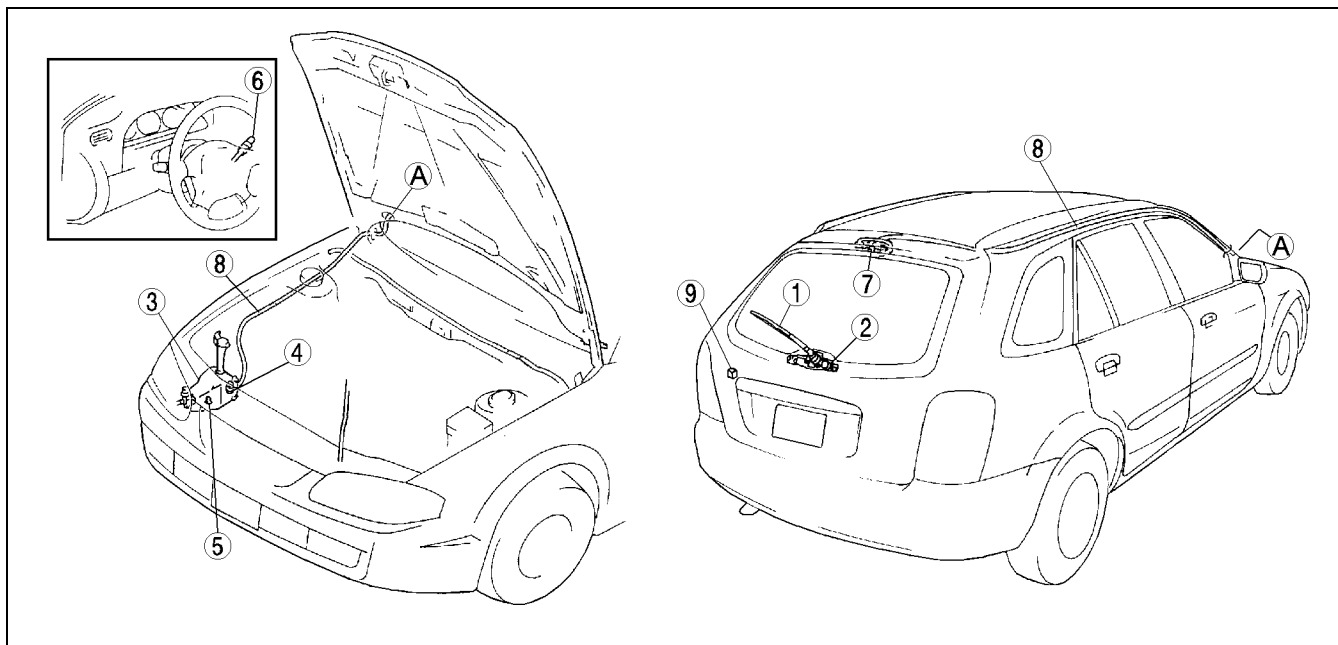

A3U0919W109

1	Rear wiper arm and blade (See 09-19-12 REAR WIPER ARM AND BLADE ADJUSTMENT) (See 09-19-12 REAR WIPER ARM AND BLADE REMOVAL/INSTALLATION)
2	Rear wiper motor (See 09-19-12 REAR WIPER MOTOR REMOVAL/INSTALLATION) (See 09-19-13 REAR WIPER MOTOR INSPECTION)
3	Windshield washer tank (See 09-19-7 WASHER TANK REMOVAL/INSTALLATION)
4	Rear washer motor (See 09-19-14 REAR WASHER MOTOR REMOVAL/INSTALLATION) (See 09-19-14 REAR WASHER MOTOR INSPECTION)
5	Washer fluid-level sensor (See 09-19-8 WASHER FLUID-LEVEL SENSOR REMOVAL/INSTALLATION) (See 09-19-8 WASHER FLUID-LEVEL SENSOR INSPECTION)

6	Wiper and washer switch (See 09-19-9 WIPER AND WASHER SWITCH REMOVAL/INSTALLATION) (See 09-19-9 WIPER AND WASHER SWITCH INSPECTION)
7	Rear washer nozzle (See 09-19-15 REAR WASHER NOZZLE ADJUSTMENT) (See 09-19-15 REAR WASHER NOZZLE CLEANING) (See 09-19-14 REAR WASHER NOZZLE REMOVAL/INSTALLATION)
8	Rear washer hose (See 09-19-15 REAR WASHER HOSE REMOVAL/INSTALLATION)
9	Intermittent rear wiper relay (See 09-19-16 INTERMITTENT REAR WIPER RELAY REMOVAL/INSTALLATION) (See 09-19-16 INTERMITTENT REAR WIPER RELAY INSPECTION)

09-19

# WIPER/WASHER SYSTEM

## WIPER/WASHER SYSTEMS WIRING DIAGRAM

A3U091901063W02

### WINDSHIELD WIPER AND WASHER SYSTEM

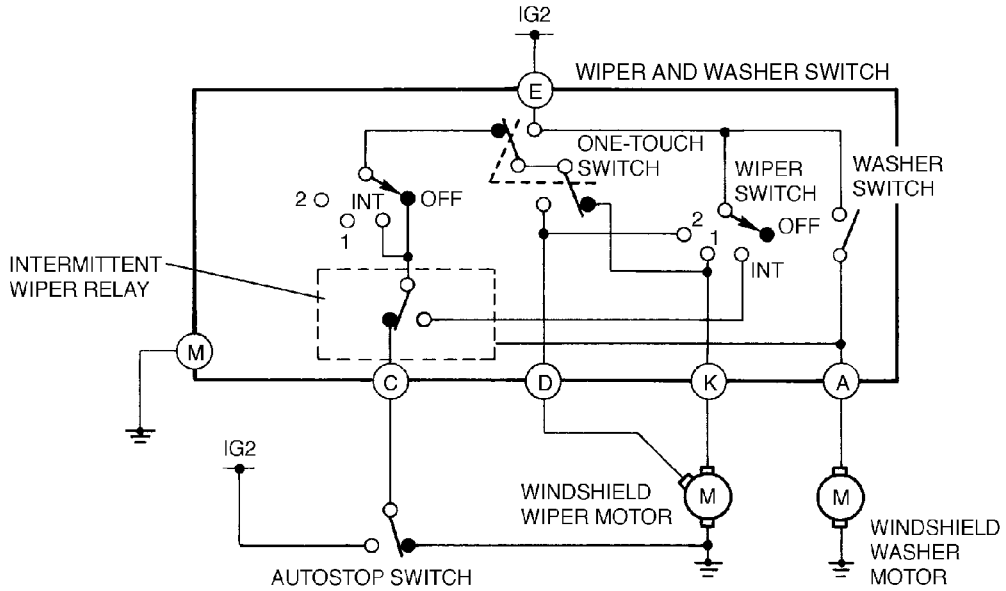

### REAR WIPER AND WASHER SYSTEM

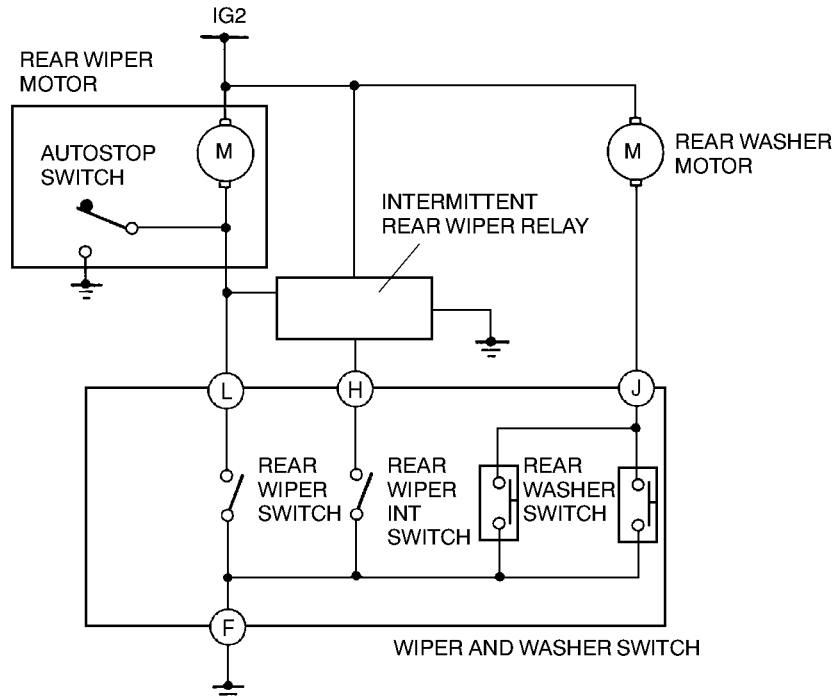

A3U0919W108

# WIPER/WASHER SYSTEM

## WINDSHIELD WIPER ARM AND BLADE ADJUSTMENT

A3U091967320W01

1. Operate the windshield wiper motor to set the wipers in the park position.
2. Align the windshield wiper blades to the marks.

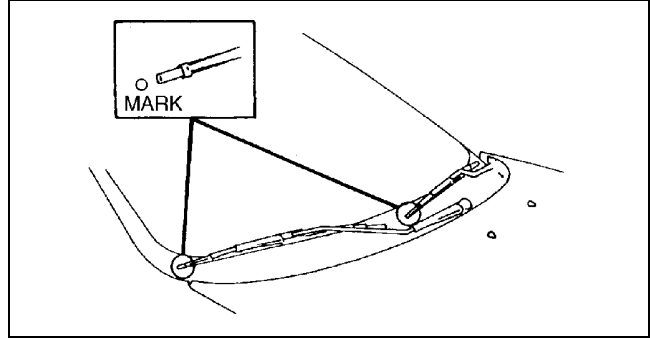

X3U919WA4

## WINDSHIELD WIPER ARM AND BLADE REMOVAL/INSTALLATION

A3U091967320W02

1. Remove in the order indicated in the table.

1	Cap
2	Nut
3	Windshield wiper arm (See 09-19-5 Windshield Wiper Arm Installation Note)
4	Windshield wiper blade
5	Rubber brush

2. Install in the reverse order of removal.
3. Adjust the windshield wiper arm and blade. (See 09-19-5 WINDSHIELD WIPER ARM AND BLADE ADJUSTMENT.)

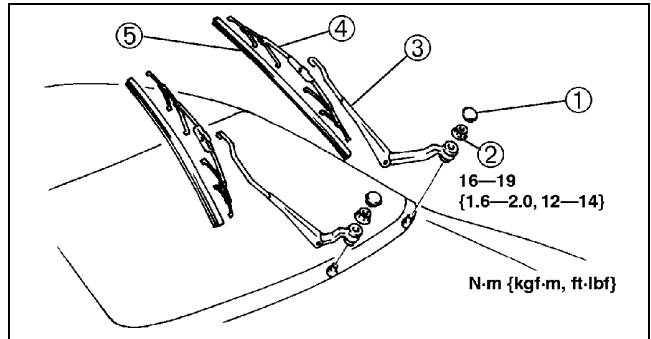

X3U919WA2

09-19

### Windshield Wiper Arm Installation Note

1. Clean the windshield wiper arm connector shafts using a wire brush before installing the windshield wiper arms.

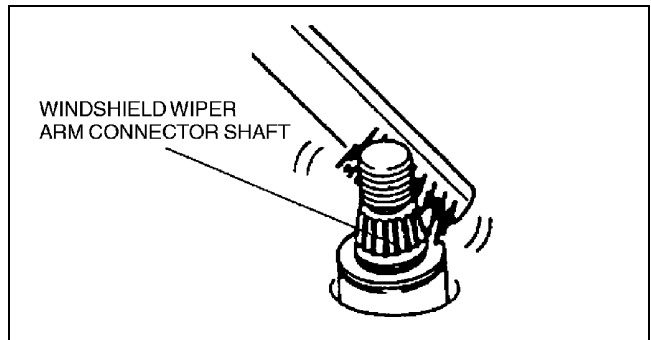

X3U919WA3

## WINDSHIELD WIPER LINK REMOVAL/INSTALLATION

A3U091967360W01

1. Remove the windshield wiper arm and blade. (See 09-19-5 WINDSHIELD WIPER ARM AND BLADE REMOVAL/INSTALLATION.)
2. Remove the cowl grille. (See 09-16-1 COWL GRILLE REMOVAL/INSTALLATION.)
3. Pry off the connection between the windshield wiper motor and windshield wiper link.
4. Remove in the order indicated in the table.

1	Bolt
2	Windshield wiper link

5. Install in the reverse order of removal.
6. Adjust the windshield wiper arm and blade. (See 09-19-5 WINDSHIELD WIPER ARM AND BLADE ADJUSTMENT.)

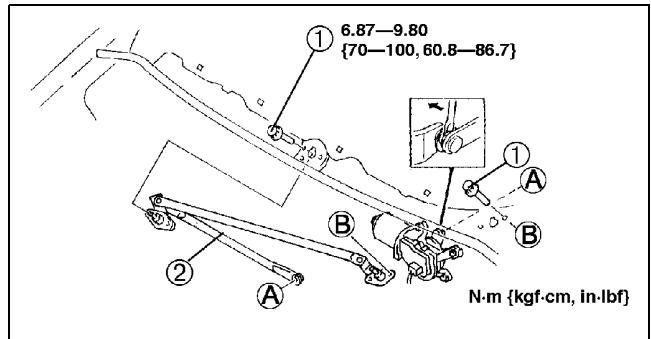

X3U919WA5

# WIPER/WASHER SYSTEM

## WINDSHIELD WIPER MOTOR REMOVAL/INSTALLATION

A3U091967340W01

1. Disconnect the negative battery cable.
2. Remove the windshield wiper arm and blade. (See 09-19-5 WINDSHIELD WIPER ARM AND BLADE REMOVAL/INSTALLATION.)
3. Remove the cowl grille. (See 09-16-1 COWL GRILLE REMOVAL/INSTALLATION.)
4. Pry off the connection between the windshield wiper motor and windshield wiper link.
5. Remove in the order indicated in the table.

1	Connector
2	Bolt
3	Windshield wiper motor

6. Install in the reverse order of removal.
7. Adjust the windshield wiper arm and blade. (See 09-19-5 WINDSHIELD WIPER ARM AND BLADE ADJUSTMENT.)

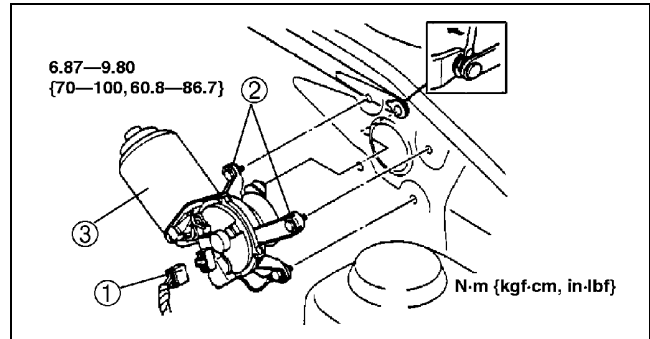

X3U919WA0

## WINDSHIELD WIPER MOTOR INSPECTION

A3U091967340W02

1. Disconnect the windshield wiper motor connector.
2. Connect battery positive voltage and inspect the operation of the windshield wiper motor as indicated below.

Terminal	Operation
A	High
C	Low

3. Disconnect battery positive voltage from terminal C of the motor while the wipers are operating.
4. Verify that the wipers do not stop in the park position.
5. Short between terminal B and C of the motor and connect battery positive voltage to terminal D of the motor.
6. Verify that the wipers operate at low speed again, then stop in the park position.
  - If not as specified, replace the windshield wiper motor.

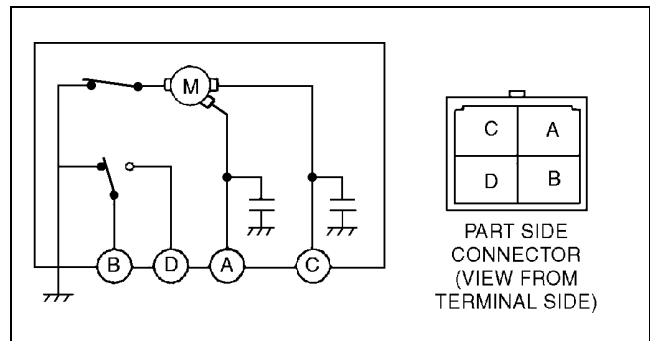

Z3U0919W001



# WIPER/WASHER SYSTEM

## WASHER TANK REMOVAL/INSTALLATION

A3U091967480W01

1. Disconnect the negative battery cable.
2. Partially peel off the right side mud guard.
3. Partially remove the right side front bumper (if equipped with washer fluid-level sensor). (See 09-10-5 FRONT BUMPER REMOVAL/INSTALLATION.)
4. Remove in the order indicated in the table.
5. Install in the reverse order of removal.

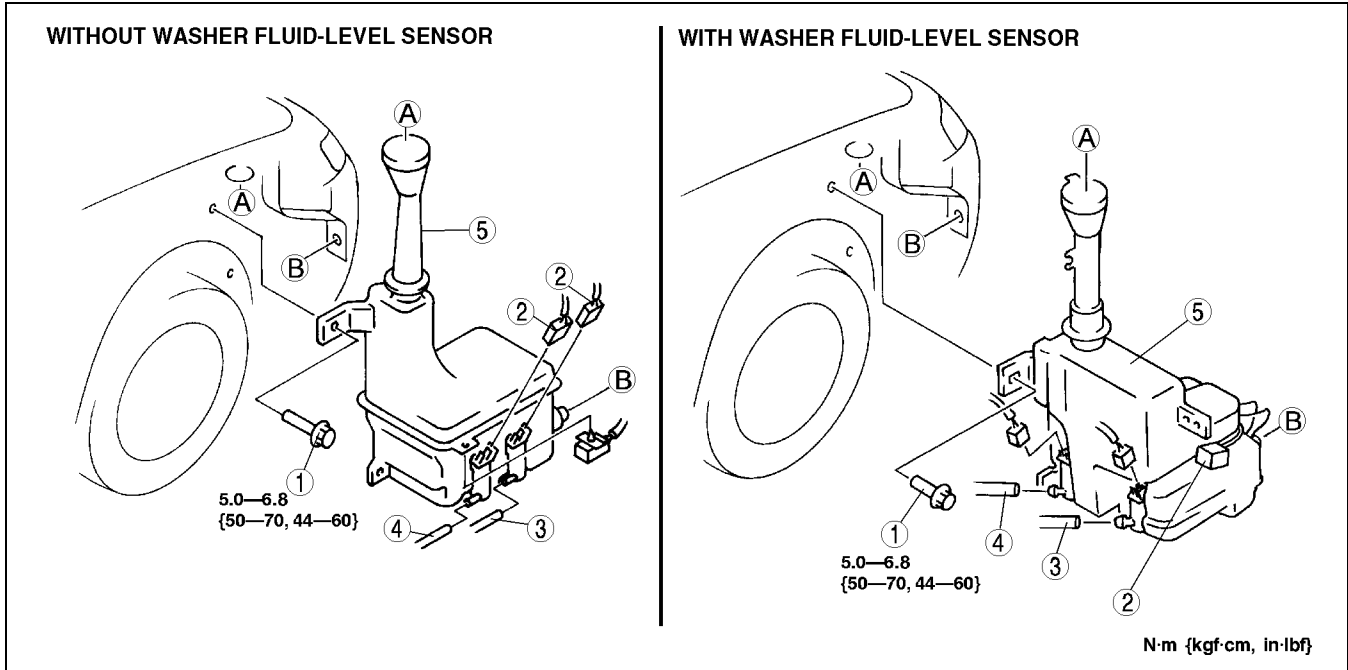

1	Bolt
2	Connector
3	Windshield washer hose

4	Rear washer hose
5	Washer tank

## WINDSHIELD WASHER MOTOR REMOVAL/INSTALLATION

A3U091976670W01

1. Disconnect the negative battery cable.
2. Remove the washer tank. (See 09-19-7 WASHER TANK REMOVAL/INSTALLATION.)
3. Remove in the order indicated in the table.

1	Windshield washer motor
2	Grommet

4. Install in the reverse order of removal.

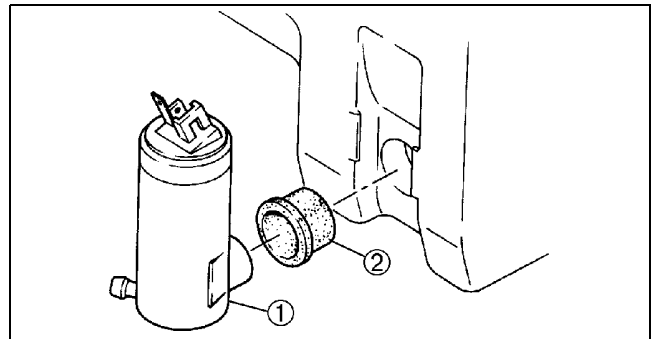

X3U919WA8

# WIPER/WASHER SYSTEM

## WINDSHIELD WASHER MOTOR INSPECTION

A3U091976670W02

1. Disconnect the negative battery cable.
2. Remove the washer tank. (See 09-19-7 WASHER TANK REMOVAL/INSTALLATION.)
3. Connect battery positive voltage to the terminal B and ground to the terminal A of the motor.
4. Verify that the windshield washer motor operates.
  - If the motor does not operate, replace the windshield washer motor.

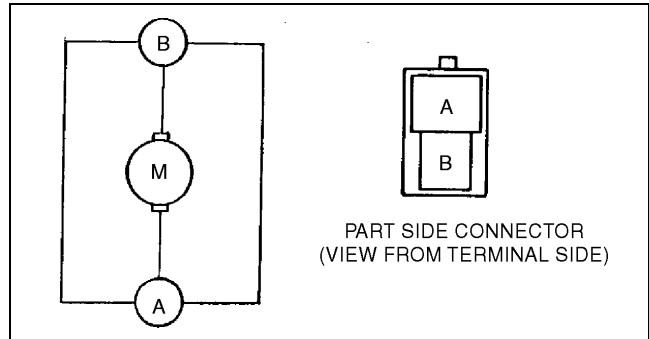

Y3U919WA3

## WASHER FLUID-LEVEL SENSOR REMOVAL/INSTALLATION

A3U091967488W01

1. Disconnect the negative battery cable.
2. Remove the washer tank. (See 09-19-7 WASHER TANK REMOVAL/INSTALLATION.)
3. Remove in the order indicated in the table.

1	Washer fluid-level sensor
2	Grommet

4. Install in the reverse order of removal.

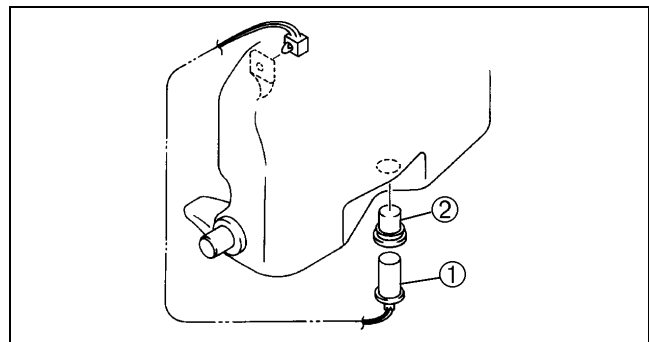

X3U919WB0

## WASHER FLUID-LEVEL SENSOR INSPECTION

A3U091967488W02

1. Disconnect the negative battery cable.
2. Remove the washer tank. (See 09-19-7 WASHER TANK REMOVAL/INSTALLATION.)
3. Inspect for continuity between the washer fluid-level sensor terminals using an ohmmeter.
  - If not as specified, replace the washer fluid-level sensor.

○—○ : Continuity

Fluid level	Terminal	
	A	B
Above Low		
Below Low	○—○	○—○

X3U919WB1

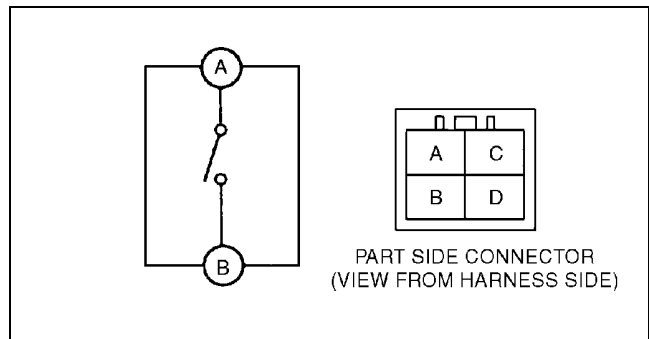

Y3U919WA4

# WIPER/WASHER SYSTEM

## WIPER AND WASHER SWITCH REMOVAL/INSTALLATION

A3U091966122W01

1. Disconnect the negative battery cable.
2. Remove the column cover. (See 09-17-5 COLUMN COVER REMOVAL/INSTALLATION.)
3. Remove in the order indicated in the table.

1	Connector
2	Screw
3	Wiper and washer switch

4. Install in the reverse order of removal.

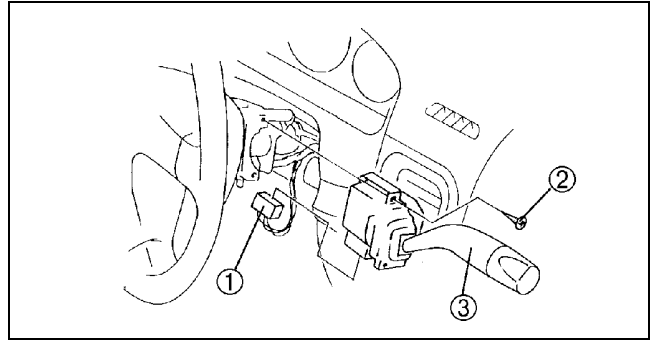

X3U919WB7

## WIPER AND WASHER SWITCH INSPECTION

A3U091966122W02

### Windshield Wiper and Washer

1. Disconnect the negative battery cable.
2. Remove the wiper and washer switch. (See 09-19-9 WIPER AND WASHER SWITCH REMOVAL/INSTALLATION.)
3. Inspect for continuity between the wiper and washer switch terminals using an ohmmeter.
  - If not as specified, replace the wiper and washer switch.

○—○ : Continuity

Switch position		One-touch	Terminal				
			A	C	E	K	O
Wiper switch	OFF	OFF		○			○
		ON			○	○	
	INT		○			○	
	1				○	○	
	2				○	○	
Washer switch	ON		○		○		

X3U919WB8

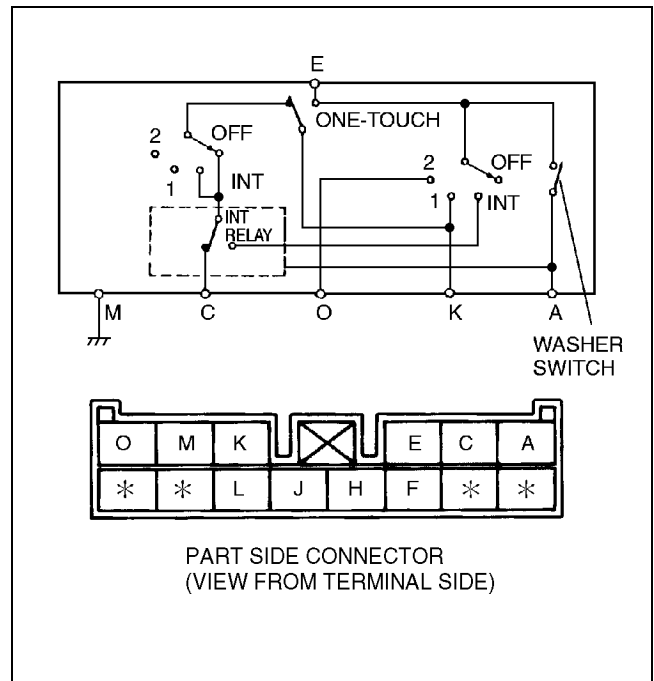

Y3U919WA5

# WIPER/WASHER SYSTEM

## Rear Wiper and Washer

1. Disconnect the negative battery cable.
2. Remove the wiper and washer switch. (See 09-19-9 WIPER AND WASHER SWITCH REMOVAL/INSTALLATION.)
3. Inspect for continuity between the wiper and washer switch terminals using an ohmmeter.
  - If not as specified, replace the wiper and washer switch.

○—○ : Continuity

Switch position	Terminal			
	F	J	H	L
OFF				
Wiper	○—○			○—○
Washer	○—○	○—○		
Wiper and washer	○—○	○—○		○—○
Wiper INT	○—○		○—○	

A3U0919W017

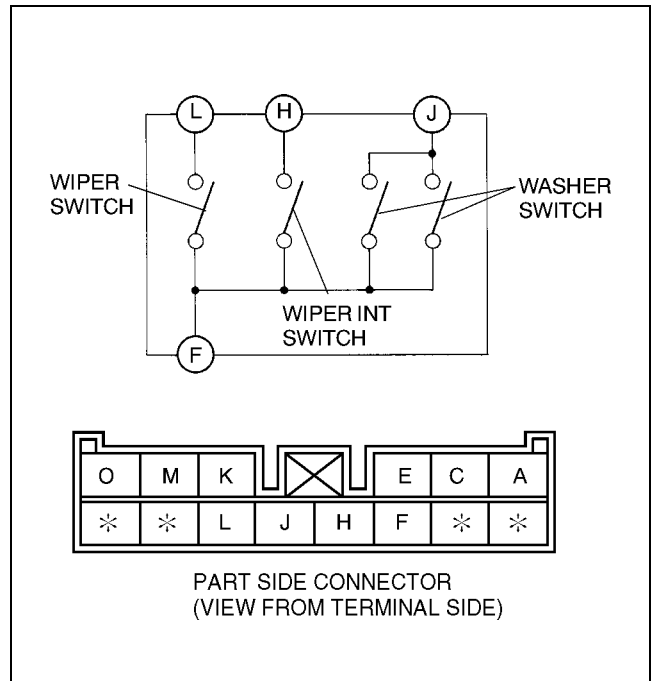

A3U0919W107

## WINDSHIELD WASHER NOZZLE ADJUSTMENT

1. Insert a needle or equivalent tool into the spray hole of the windshield washer nozzle and adjust the nozzle direction as shown.

A3U091967510W01

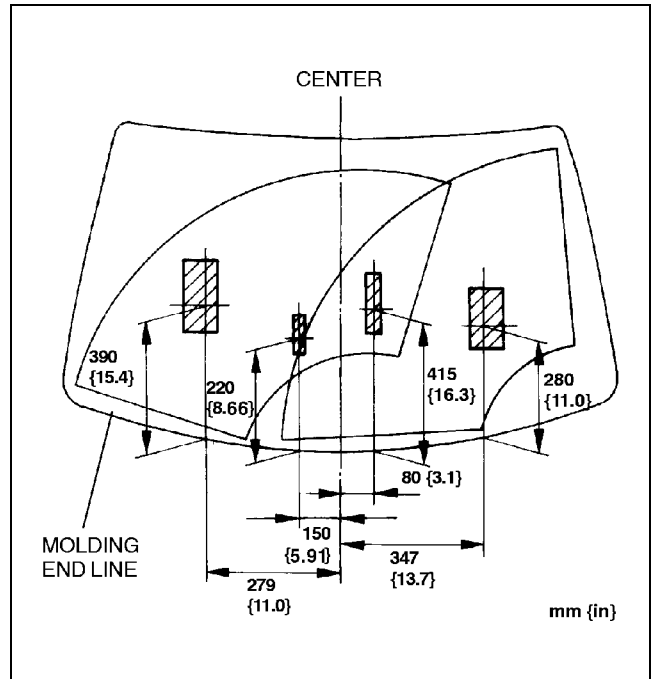

Y3U919WA6

# WIPER/WASHER SYSTEM

## WINDSHIELD WASHER NOZZLE CLEANING

A3U091967510W02

1. Clean the washer nozzle by inserting and moving a needle or similar tool back and forth.
  - If the nozzle becomes clogged again after cleaning, remove the hose from washer nozzle. Make sure there is enough washer fluid. Then turn the washer switch on and flush the inside of the hose.

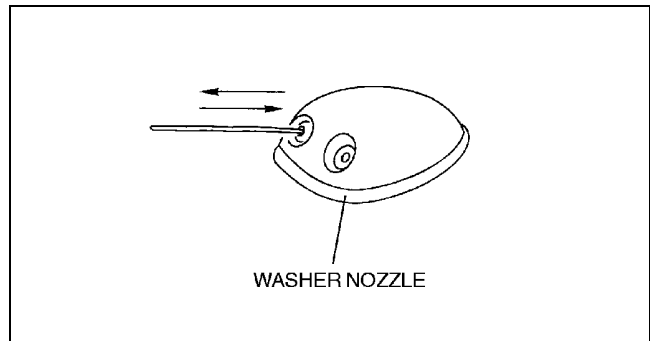

Y3U919WA7

## WINDSHIELD WASHER NOZZLE REMOVAL

A3U091967510W03

1. Remove the bonnet insulator.
2. Disconnect the windshield washer hose to windshield washer nozzle.
3. Remove the windshield washer nozzle using a **10 mm {0.4 in}** deep socket wrench from underneath the bonnet.

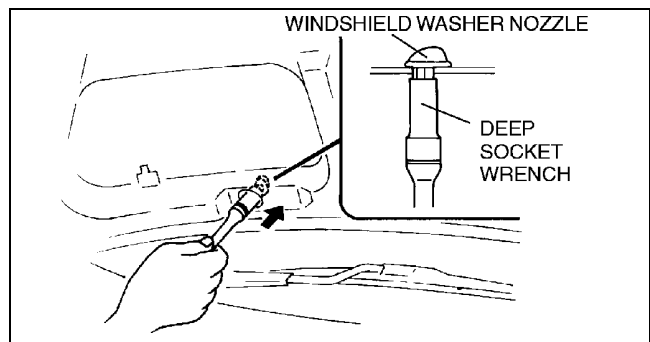

X3U919WB3

09-19

## WINDSHIELD WASHER NOZZLE INSTALLATION

A3U091967510W04

1. Connect the windshield washer hose to windshield washer nozzle.
2. Push the windshield washer nozzle into the installation hole.
3. Adjust the windshield washer nozzle. (See 09-19-10 WINDSHIELD WASHER NOZZLE ADJUSTMENT.)
4. Install the bonnet insulator.

## WINDSHIELD WASHER HOSE REMOVAL/INSTALLATION

A3U091967500W01

1. Remove the bonnet insulator.
2. Partially peel off the right side mud guard.
3. Remove in the order indicated in the table.

1	Clip
2	Joint pipe
3	Windshield washer hose

4. Install in the reverse order of removal.

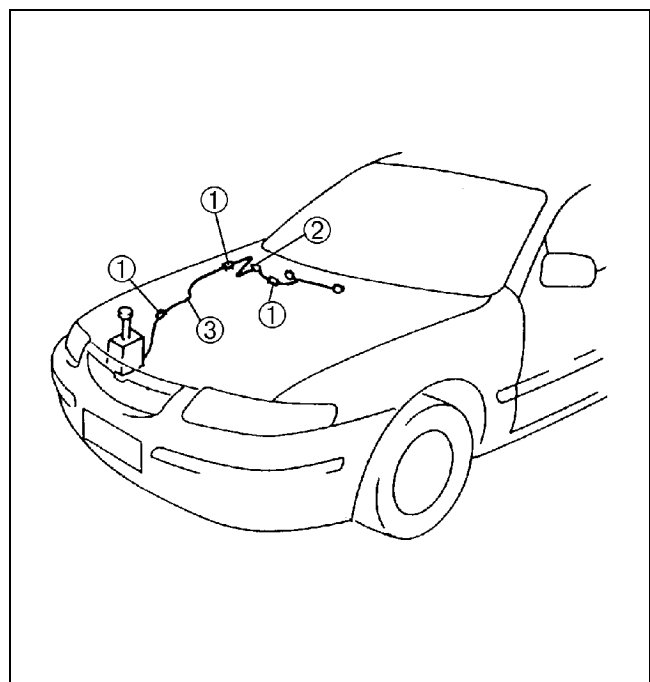

X3U919WB6

# WIPER/WASHER SYSTEM

## REAR WIPER ARM AND BLADE ADJUSTMENT

A3U091967420W01

1. Operate the rear wiper motor to set the wiper in the park position.
2. Set the rear wiper arm height as shown.

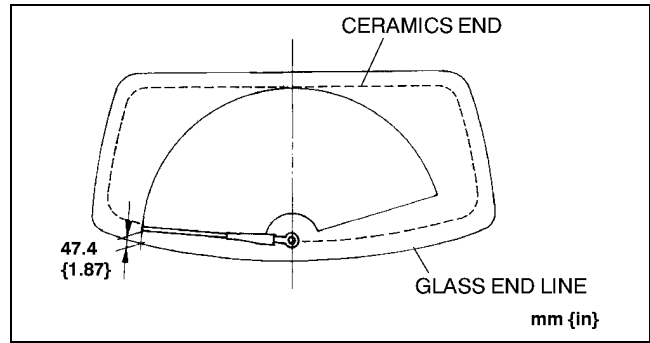

A3U0919W008

## REAR WIPER ARM AND BLADE REMOVAL/INSTALLATION

A3U091967420W02

1. Remove in the order indicated in the table.

1	Nut
2	Rear wiper arm (See 09-19-12 Rear Wiper Arm Installation Note)
3	Rear wiper blade
4	Rubber brush

2. Install in the reverse order of removal.
3. Adjust the rear wiper arm and blade. (See 09-19-12 REAR WIPER ARM AND BLADE ADJUSTMENT.)

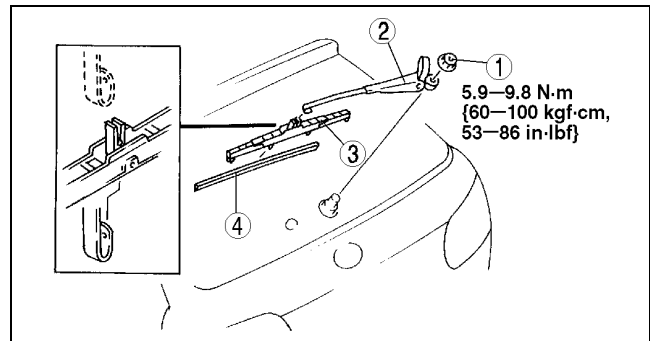

A3U0919W006

### Rear Wiper Arm Installation Note

1. Clean the rear wiper arm connector shaft using a wire brush before installing the rear wiper arm.

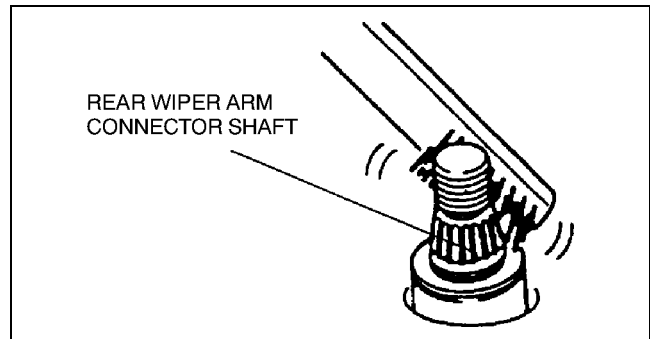

YMU919WAR

## REAR WIPER MOTOR REMOVAL/INSTALLATION

A3U091967450W01

1. Disconnect the negative battery cable.
2. Remove the rear wiper arm and blade. (See 09-19-12 REAR WIPER ARM AND BLADE REMOVAL/INSTALLATION.)
3. Remove the liftgate trim. (See 09-17-16 LIFTGATE TRIM REMOVAL/INSTALLATION.)
4. Remove in the order indicated in the table.

1	Connector
2	Seal cap
3	Nut
4	Washer
5	Outer bushing
6	Bolt
7	Rear wiper motor
8	Washer

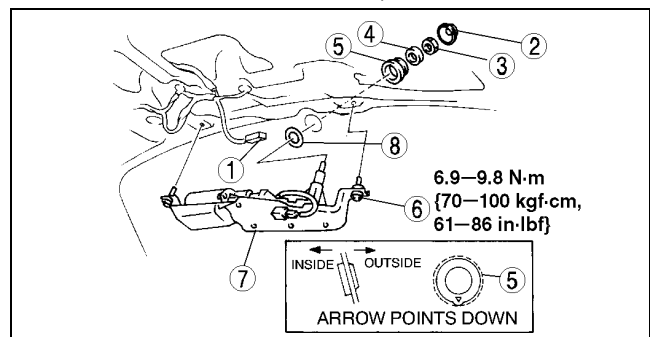

A3U0919W001

5. Install in the reverse order of removal.
6. Adjust the rear wiper arm and blade. (See 09-19-12 REAR WIPER ARM AND BLADE ADJUSTMENT.)

# WIPER/WASHER SYSTEM

## REAR WIPER MOTOR INSPECTION

A3U091967450W02

1. Disconnect the negative battery cable.
2. Remove the liftgate trim. (Refer to 09-17-16 LIFTGATE TRIM REMOVAL/INSTALLATION.)
3. Disconnect the rear wiper motor connector.
4. Connect battery positive voltage to the rear wiper motor terminal A and the ground to a bare metal part of the vehicle and the rear wiper motor terminal B.
5. Verify that the rear wiper motor operates.

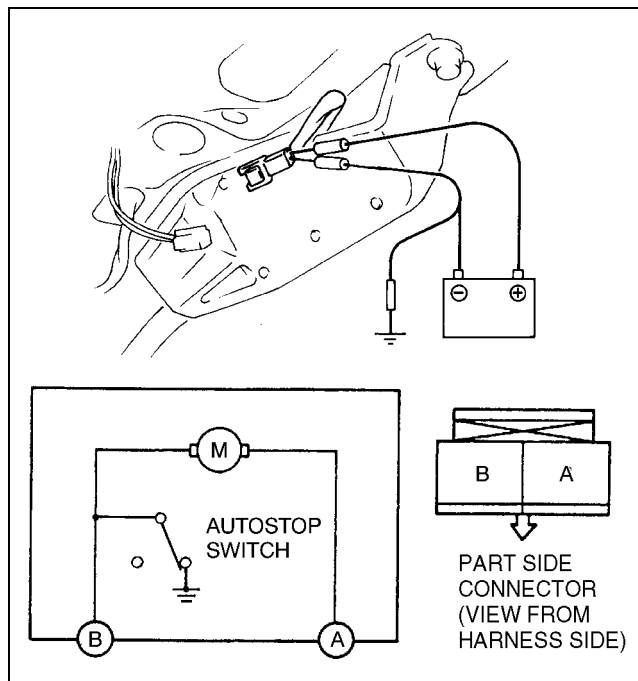

A3U0919W101

6. Disconnect the ground to the terminal B while the rear wiper is operating.
7. Verify that the rear wiper stops in the park position.
  - If not as specified, replace the rear wiper motor.

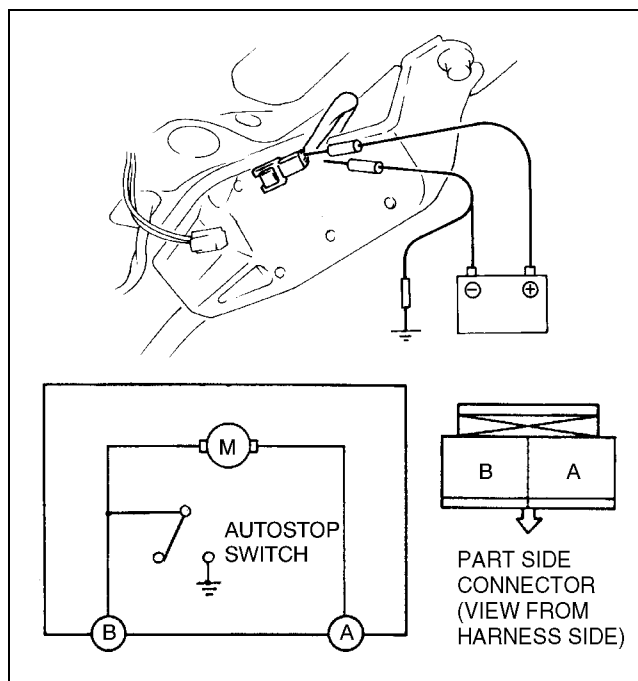

A3U0919W102

09-19

# WIPER/WASHER SYSTEM

## REAR WASHER MOTOR REMOVAL/INSTALLATION

A3U091976672W01

1. Disconnect the negative battery cable.
2. Partially peel off the right side mud guard.
3. Remove the washer tank. (See 09-19-7 WASHER TANK REMOVAL/INSTALLATION.)
4. Remove in the order indicated in the table.

1	Rear washer motor
2	Grommet

5. Install in the reverse order of removal.

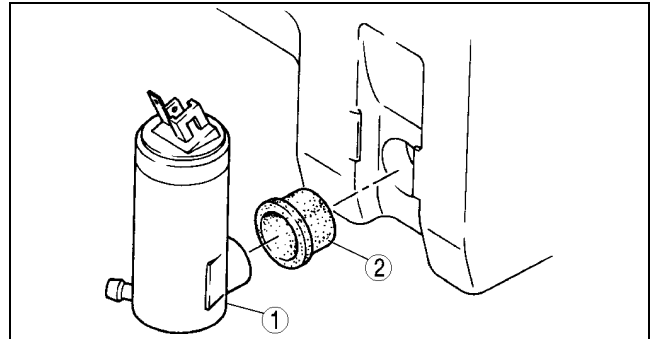

YMU919WAT

## REAR WASHER MOTOR INSPECTION

A3U091976672W02

1. Remove the washer tank. (See 09-19-7 WASHER TANK REMOVAL/INSTALLATION.)
2. Connect battery positive voltage to the terminal B and ground to the terminal A of the motor.
3. Verify that the rear washer motor operates.
  - If the motor does not operate, replace the rear washer motor.

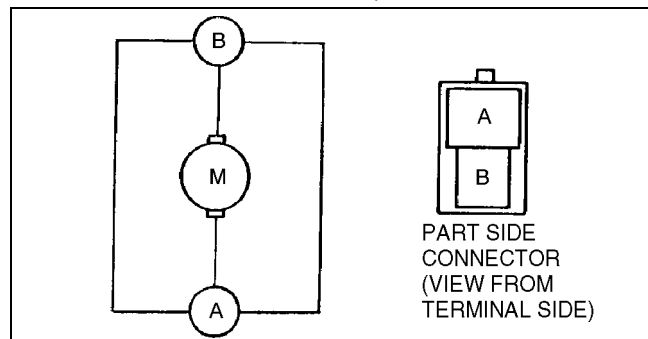

A3U0919W103

## REAR WASHER NOZZLE REMOVAL/INSTALLATION

A3U091967511W01

1. Disconnect the negative battery cable.
2. Remove the rear spoiler. (See 09-16-8 REAR SPOILER REMOVAL/INSTALLATION.)
3. Remove the rear washer hose from the rear washer nozzle.
4. Compress the hooks of the rear washer nozzle.
5. Pull the rear washer nozzle out to remove it.
6. Install in the reverse order of removal.
7. Adjust the rear washer nozzle. (See 09-19-15 REAR WASHER NOZZLE ADJUSTMENT.)

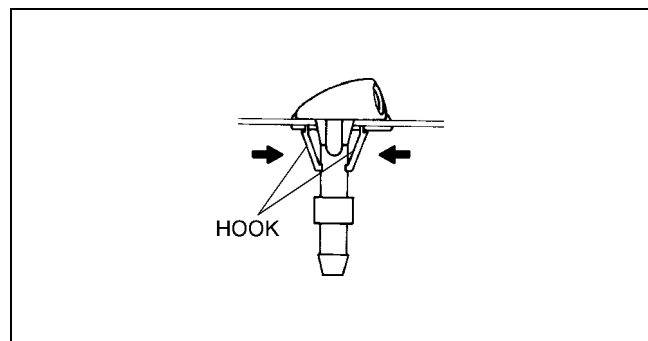

A3U0919W011



# WIPER/WASHER SYSTEM

## REAR WASHER NOZZLE ADJUSTMENT

A3U091967511W02

1. Insert a needle or equivalent tool into the spray hole of the rear washer nozzle and adjust the nozzle direction as shown.

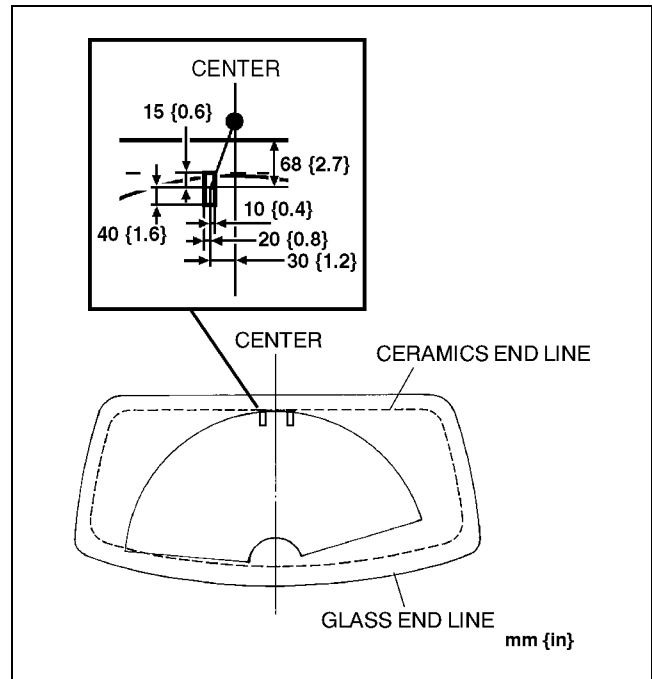

A3U0919W110

## REAR WASHER NOZZLE CLEANING

1. Clean the rear washer nozzle. (See 09-19-11 WINDSHIELD WASHER NOZZLE CLEANING.)

A3U091967511W03

## REAR WASHER HOSE REMOVAL/INSTALLATION

1. Disconnect the negative battery cable.
2. Remove the headliner. (See 09-17-16 HEADLINER REMOVAL/INSTALLATION.)
3. Remove the rear washer hose from the clips.
4. Partially peel off the right side mud guard and remove the rear washer hose from the clip.

A3U091967470W01

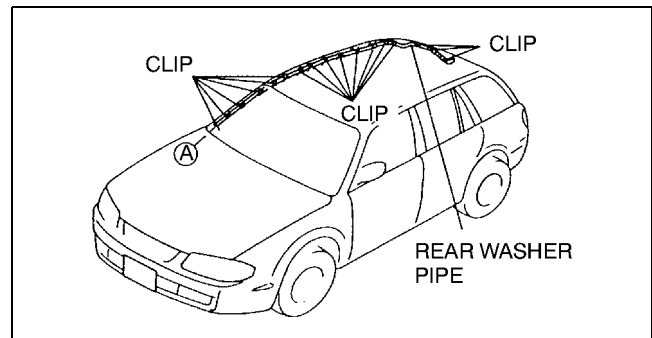

A3U0919W104

5. Remove the rear washer hose from the washer tank.
6. Install in the reverse order of removal.

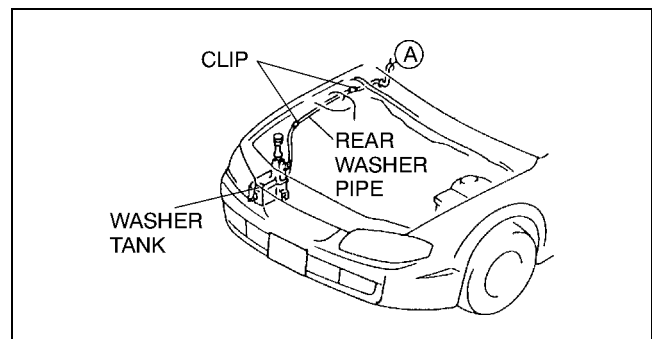

A3U0919W105

# WIPER/WASHER SYSTEM

## INTERMITTENT REAR WIPER RELAY REMOVAL/INSTALLATION

A3U091966810W01

1. Disconnect the negative battery cable.
2. Remove the left side trunk side trim. (See 09-17-15 TRUNK SIDE TRIM REMOVAL/INSTALLATION.)
3. Remove in the order indicated in the table.

1	Nut
2	Connector
3	Intermittent rear wiper relay

4. Install in the reverse order of removal.

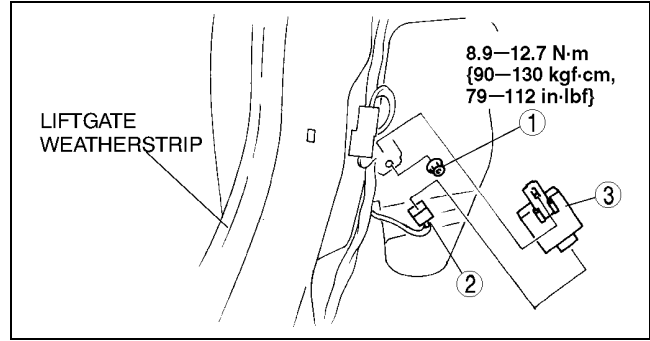

A3U0919W111

## INTERMITTENT REAR WIPER RELAY INSPECTION

A3U091966810W02

1. Measure the voltage at the intermittent rear wiper relay terminals as indicated below.
2. Disconnect the intermittent rear wiper relay connector before inspecting for continuity at the terminal H.
  - If not as specified, inspect the parts listed under “Action”.
  - If the parts and wiring harnesses are okay but the system still does not work properly, replace the intermittent rear wiper relay.

### Terminal Voltage Table (Reference)

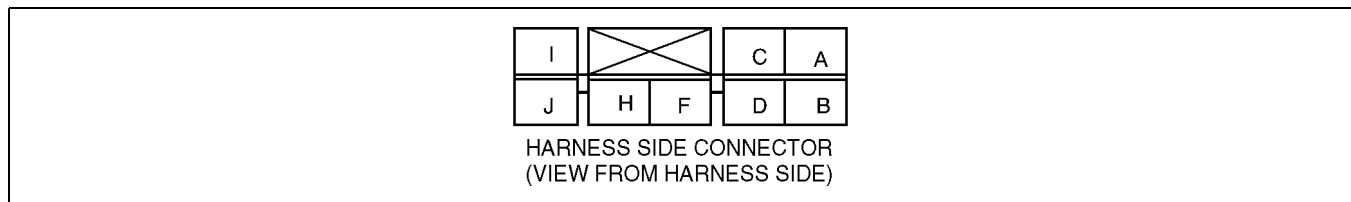

A3U0919W106

Terminal	Signal	Connected to	Test condition	Voltage (V)/ Continuity	Action
A	—	—	—	—	—
B	IG2	R. WIP 10 A fuse	Ignition switch at ON position	B+	<ul style="list-style-type: none"> <li>• Inspect R. WIP 10 A fuse</li> <li>• Inspect related harness</li> </ul>
			Other	Below 1.0	
C	—	—	—	—	—
D	—	—	—	—	—
F	Rear wiper switch INT	Rear wiper switch	Ignition switch at ON position	Below 1.0	<ul style="list-style-type: none"> <li>• Inspect R. WIP 10 A fuse</li> <li>• Inspect wiper and washer switch (See 09-19-9 WIPER AND WASHER SWITCH INSPECTION)</li> <li>• Inspect related harness</li> </ul>
			Rear wiper switch at OFF position	B+	
H	GND	GND	Under any condition: inspect for continuity to ground	Yes	<ul style="list-style-type: none"> <li>• Inspect GND</li> </ul>
I	—	—	—	—	—
J	Autostop	Rear wiper motor	Ignition switch at ON position	Rear wiper is operating (INT position) Alternates below 1.0 and B+	<ul style="list-style-type: none"> <li>• Inspect R. WIP 10 A fuse</li> <li>• Inspect wiper and washer switch (See 09-19-9 WIPER AND WASHER SWITCH INSPECTION)</li> <li>• Inspect rear wiper motor (See 09-19-13 REAR WIPER MOTOR INSPECTION)</li> <li>• Inspect related harness</li> </ul>
			Other	B+	

**09-20 ENTERTAINMENT**

LOCATION INDEX ..... 09-20-1  
 PILLAR ANTENNA REMOVAL..... 09-20-2  
 PILLAR ANTENNA INSTALLATION ... 09-20-2  
 PILLAR ANTENNA INSPECTION..... 09-20-2  
 REAR CENTER ROOF ANTENNA  
 REMOVAL/INSTALLATION ..... 09-20-3  
 REAR CENTER ROOF ANTENNA  
 INSPECTION..... 09-20-3  
 FRONT DOOR SPEAKER  
 REMOVAL/INSTALLATION ..... 09-20-3  
 REAR DOOR SPEAKER  
 REMOVAL/INSTALLATION ..... 09-20-3  
 DOOR SPEAKER INSPECTION..... 09-20-4  
 REAR PACKAGE SPEAKER  
 REMOVAL/INSTALLATION ..... 09-20-4  
 REAR PACKAGE SPEAKER  
 INSPECTION ..... 09-20-4  
 FRONT ANTENNA FEEDER  
 REMOVAL/INSTALLATION ..... 09-20-5  
 FRONT ANTENNA FEEDER  
 INSPECTION ..... 09-20-5

REAR ANTENNA FEEDER  
 REMOVAL/INSTALLATION..... 09-20-5  
 REAR ANTENNA FEEDER  
 INSPECTION ..... 09-20-6  
 AUDIO UNIT REMOVAL ..... 09-20-6  
 AUDIO UNIT INSTALLATION ..... 09-20-6  
 UPPER MODULE  
 REMOVAL/INSTALLATION..... 09-20-7  
 Upper Module Removal Note ..... 09-20-7  
 Cover Removal Note..... 09-20-7  
 Screw Installation Note..... 09-20-7  
 LOWER MODULE  
 REMOVAL/INSTALLATION..... 09-20-8  
 Cover Removal Note..... 09-20-8  
 Screw Installation Note..... 09-20-8  
 CIGARETTE LIGHTER  
 REMOVAL/INSTALLATION..... 09-20-8  
 Socket Removal Note ..... 09-20-9  
 Ring Removal Note..... 09-20-9  
 CIGARETTE LIGHTER INSPECTION ... 09-20-9

LOCATION INDEX

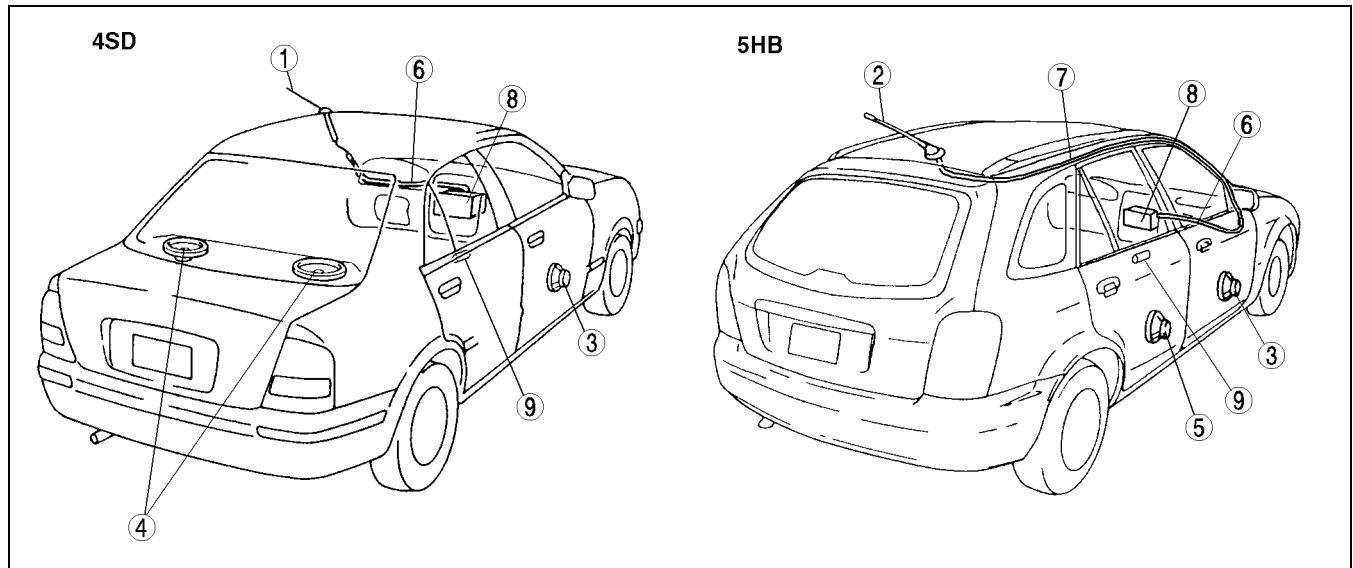

A3U0920W102

1	Pillar antenna (See 09-20-2 PILLAR ANTENNA REMOVAL) (See 09-20-2 PILLAR ANTENNA INSTALLATION) (See 09-20-2 PILLAR ANTENNA INSPECTION)
2	Rear center roof antenna (See 09-20-3 REAR CENTER ROOF ANTENNA REMOVAL/INSTALLATION) (See 09-20-3 REAR CENTER ROOF ANTENNA INSPECTION)
3	Front door speaker (See 09-20-3 FRONT DOOR SPEAKER REMOVAL/INSTALLATION) (See 09-20-4 DOOR SPEAKER INSPECTION)
4	Rear package speaker (See 09-20-4 REAR PACKAGE SPEAKER REMOVAL/INSTALLATION) (See 09-20-4 REAR PACKAGE SPEAKER INSPECTION)

5	Rear door speaker (See 09-20-3 REAR DOOR SPEAKER REMOVAL/ INSTALLATION) (See 09-20-4 DOOR SPEAKER INSPECTION)
6	Front antenna feeder (See 09-20-5 FRONT ANTENNA FEEDER REMOVAL/INSTALLATION) (See 09-20-5 FRONT ANTENNA FEEDER INSPECTION)
7	Rear antenna feeder (See 09-20-5 REAR ANTENNA FEEDER REMOVAL/INSTALLATION) (See 09-20-6 REAR ANTENNA FEEDER INSPECTION)
8	Audio unit (See 09-20-6 AUDIO UNIT REMOVAL) (See 09-20-6 AUDIO UNIT INSTALLATION)

9	Cigarette lighter (See 09-20-8 CIGARETTE LIGHTER REMOVAL/ INSTALLATION) (See 09-20-9 CIGARETTE LIGHTER INSPECTION)
---	--

### PILLAR ANTENNA REMOVAL

1. Disconnect the negative battery cable.
2. Remove the driver-side front side trim. (See 09-17-13 FRONT SIDE TRIM REMOVAL/INSTALLATION.)
3. Disconnect the pillar antenna plug.

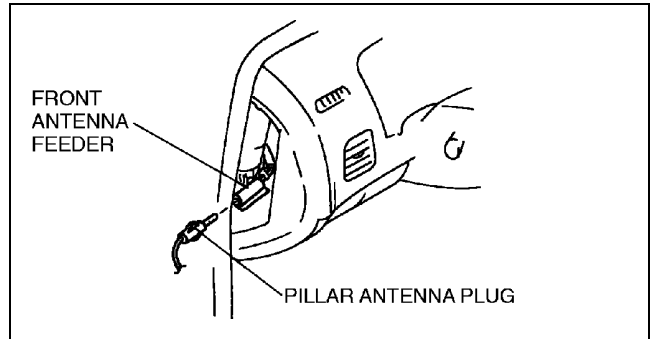

4. Remove the screw and pull out the pillar antenna.

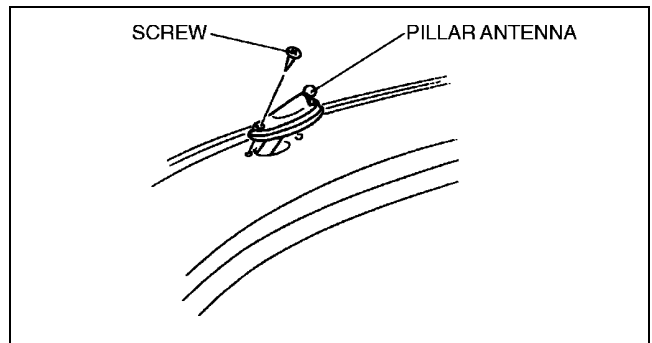

### PILLAR ANTENNA INSTALLATION

1. Tape the antenna plug to the antenna drain pipe.
2. Pass the pillar antenna and antenna drain pipe through the A-pillar from the hole in the roof.
3. Install the screws and install the roof antenna.
4. Connect the antenna plug.
5. Install the driver-side front side trim. (See 09-17-13 FRONT SIDE TRIM REMOVAL/INSTALLATION.)
6. Connect the negative battery cable.

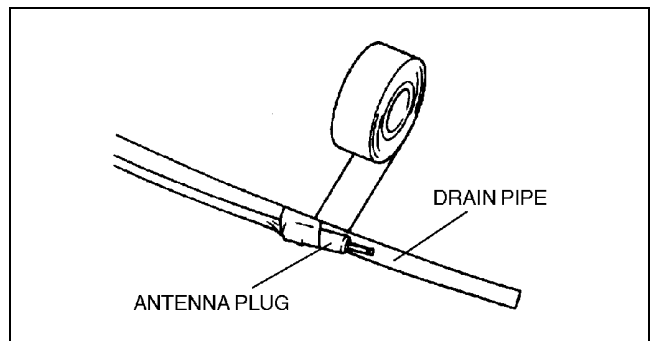

### PILLAR ANTENNA INSPECTION

1. Remove the driver-side front side trim. (See 09-17-13 FRONT SIDE TRIM REMOVAL/INSTALLATION.)
2. Disconnect the pillar antenna plug.
3. Verify that there is no continuity between pillar antenna terminal A and B using an ohmmeter.
  - If not as specified, replace the pillar antenna.
4. Inspect for continuity between the pillar antenna terminals using an ohmmeter.
  - If not as specified, replace the pillar antenna.

○—○ : Continuity

Step	Terminal			
	A	B	C	D
1	○		○	
2		○		○

X3U920WAB

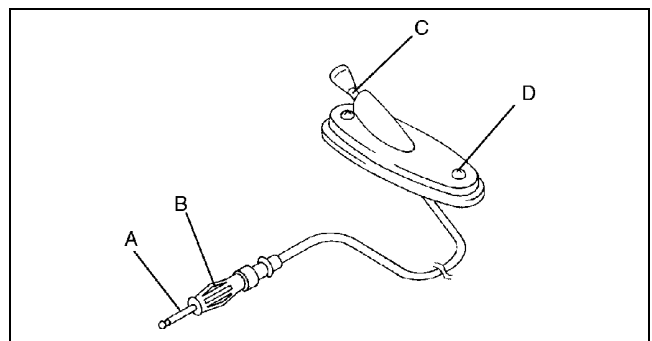

## REAR CENTER ROOF ANTENNA REMOVAL/INSTALLATION

A3U092066939W01

1. Disconnect the negative battery cable.
2. Remove the headliner. (See 09-17-16 HEADLINER REMOVAL/INSTALLATION.)
3. Remove in the order indicated in the table.

1	Antenna rod
2	Rear center roof antenna feeder
3	Nut
4	Rear center roof antenna

4. Install in the reverse order of removal.
5. After installation, verify that the rubber of the rear center roof antenna is installed to the roof panel with no space between them.

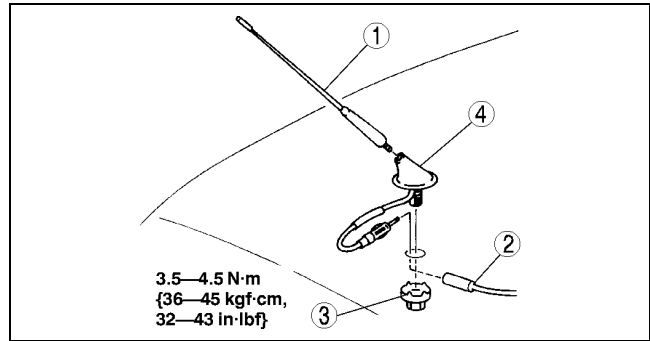

Y3A8124W001

## REAR CENTER ROOF ANTENNA INSPECTION

A3U092066939W02

1. Remove the headliner. (See 09-17-16 HEADLINER REMOVAL/INSTALLATION.)
2. Disconnect the rear center roof antenna jack.
3. Remove the antenna rod.
4. Verify that there is no continuity between roof antenna terminals A and B using an ohmmeter.
5. Inspect for continuity between the rear center roof antenna terminals using an ohmmeter.
  - If not as specified, replace the rear center roof antenna.

○—○ : Continuity

Step	Terminal			
	A	B	C	D
1	○		○	
2		○		○

Y3A8124W002

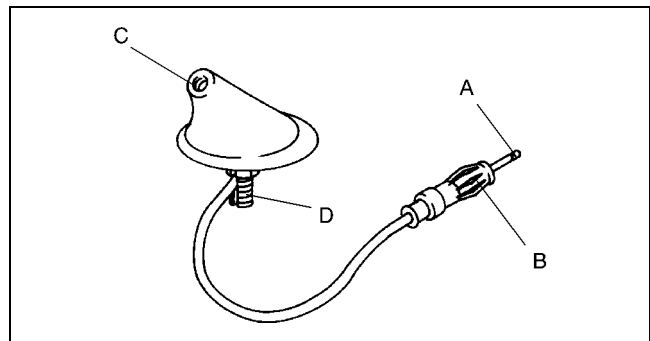

Y3A8124W003

09-20

## FRONT DOOR SPEAKER REMOVAL/INSTALLATION

A3U092066961W01

1. Disconnect the negative battery cable.
2. Remove the front door trim. (See 09-17-9 FRONT DOOR TRIM REMOVAL/INSTALLATION.)
3. Remove the screws.
4. Disconnect the connector and remove the front door speaker.
5. Install in the reverse order of removal.

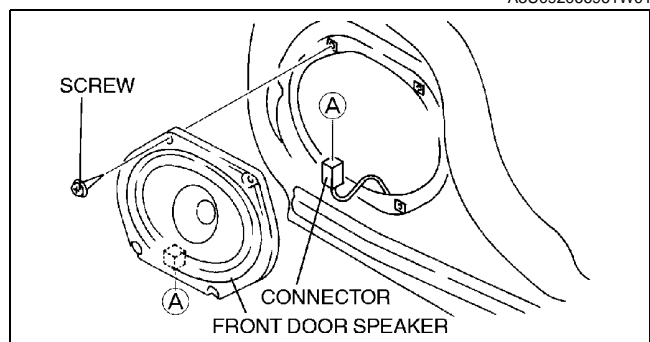

X3U920WA2

## REAR DOOR SPEAKER REMOVAL/INSTALLATION

A3U092066961W02

1. Disconnect the negative battery cable.
2. Remove the rear door trim. (See 09-17-9 REAR DOOR TRIM REMOVAL/INSTALLATION.)
3. Remove the screws.
4. Disconnect the connector and remove the rear door speaker.
5. Install in the reverse order of removal.

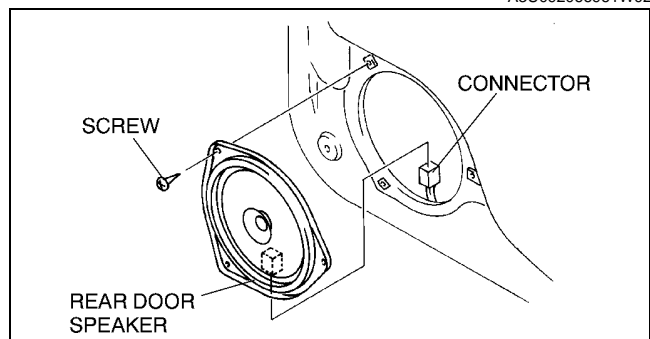

A3U0920W001

## DOOR SPEAKER INSPECTION

A3U092066961W03

1. Remove the door speaker.
2. Inspect for resistance between the door speaker terminals using an ohmmeter.

○—W—○ : Resistance

Test condition	Terminal	
	A	B
Constant	○—W—○	○ R

R: 4 ohms

Z3U0920W002

3. To verify that the speakers output sound, apply voltage to each speaker and release using a 1.5-V battery.
  - If not as specified, replace the door speaker.

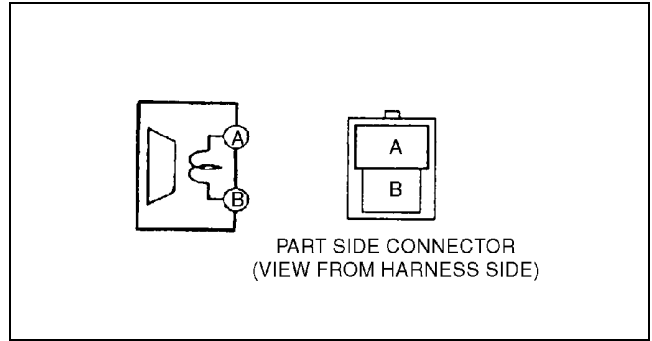

Y3U920WA0

## REAR PACKAGE SPEAKER REMOVAL/INSTALLATION

A3U092066964W01

1. Disconnect the negative battery cable.
2. Remove the rear package trim. (See 09-17-12 REAR PACKAGE TRIM REMOVAL/INSTALLATION.)
3. Remove the screws.
4. Disconnect the connector and remove the rear package speaker.
5. Install in the reverse order of removal.

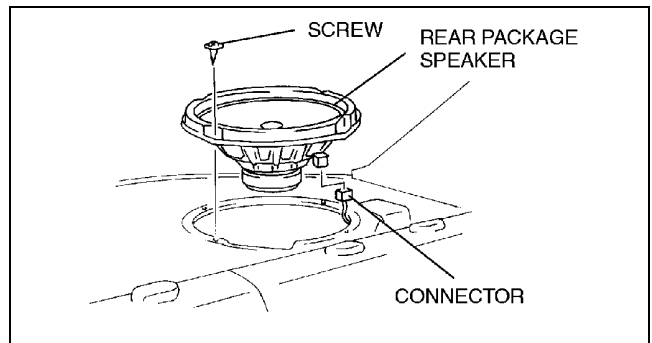

X3U920WA5

## REAR PACKAGE SPEAKER INSPECTION

A3U092066964W02

1. Remove the rear package speaker.
2. Inspect for resistance between the rear package speaker terminals using an ohmmeter.

○—W—○ : Resistance

Test condition	Terminal	
	A	B
Constant	○—W—○	○ R

R: 4 ohms

Z3U0920W002

3. To verify that the speakers output sound, apply voltage to each speaker and release using a 1.5-V battery.
  - If not as specified, replace the rear package speaker.

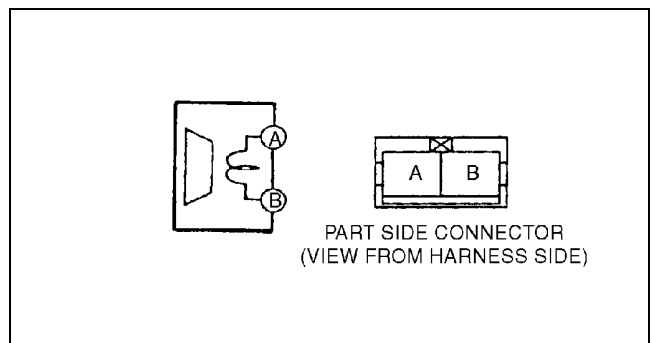

Y3U920WA1

## FRONT ANTENNA FEEDER REMOVAL/INSTALLATION

A3U092066941W01

1. Disconnect the negative battery cable.
2. Remove the audio unit. (See 09–20–6 AUDIO UNIT REMOVAL.) (See 09–20–6 AUDIO UNIT INSTALLATION.)
3. Remove the driver-side front side trim. (See 09–17–13 FRONT SIDE TRIM REMOVAL/INSTALLATION.)
4. Disconnect the connection between the pillar antenna and the front antenna feeder.
5. Remove in the order indicated in the table.

1	Clip
2	Front antenna feeder

6. Install in the reverse order of removal.

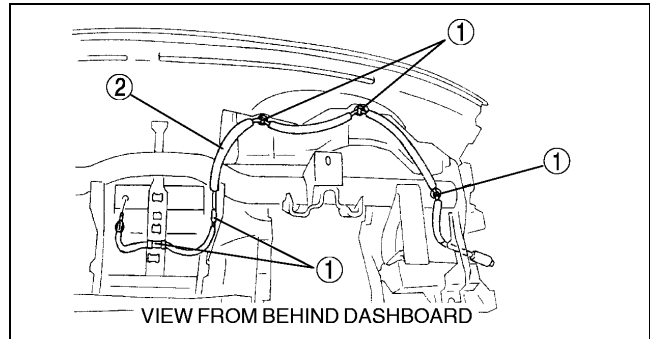

X3U920WAD

## FRONT ANTENNA FEEDER INSPECTION

A3U092066941W02

1. Disconnect the negative battery cable.
2. Remove the audio unit. (See 09–20–6 AUDIO UNIT REMOVAL.) (See 09–20–6 AUDIO UNIT INSTALLATION.)
3. Remove the driver-side front side trim. (See 09–17–13 FRONT SIDE TRIM REMOVAL/INSTALLATION.)
4. Disconnect the connection between the pillar antenna and the front antenna feeder.
5. Verify that there is no continuity between the front antenna feeder terminals A and B using an ohmmeter.
  - If not as specified, replace the front antenna feeder.
6. Inspect for continuity between the front antenna feeder terminals using an ohmmeter.
  - If not as specified, replace the front antenna feeder.

09–20

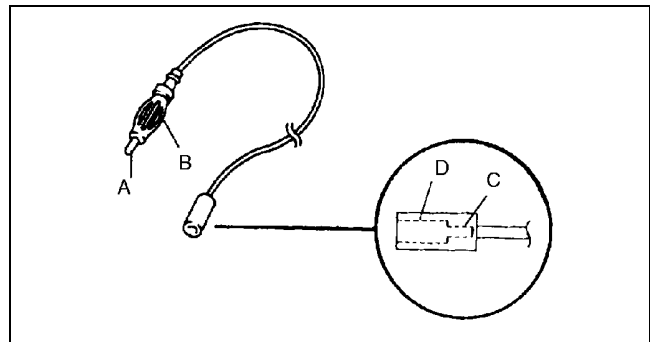

X3U920WAF

○—○ : Continuity

Step	Terminal			
	A	B	C	D
1	○—○		○—○	
2		○—○		○—○

X3U920WAE

## REAR ANTENNA FEEDER REMOVAL/INSTALLATION

A3U092066942W01

1. Disconnect the negative battery cable.
2. Remove the right-side front side trim. (See 09–17–13 FRONT SIDE TRIM REMOVAL/INSTALLATION.)
3. Remove the right-side A-pillar trim. (See 09–17–10 A-PILLAR TRIM REMOVAL/INSTALLATION.)
4. Remove the headliner. (See 09–17–16 HEADLINER REMOVAL/INSTALLATION.)
5. Disconnect the connector between the rear center roof antenna and rear antenna feeder.
6. Disconnect the connector between the front antenna feeder and rear antenna feeder.
7. Remove in the order indicated in the table.

1	Clip
2	Rear antenna feeder

8. Install in the reverse order of removal.

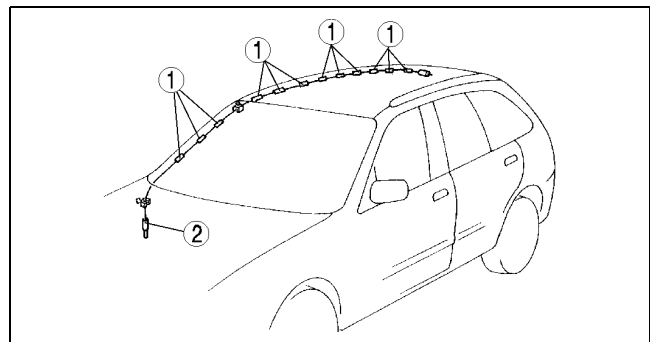

Y3A8124W004

# ENTERTAINMENT

## REAR ANTENNA FEEDER INSPECTION

A3U092066942W02

1. Remove the rear antenna feeder.
2. Verify that there is no continuity between rear antenna feeder terminals A and B using an ohmmeter.
3. Inspect for continuity between the rear antenna feeder terminals using an ohmmeter.
  - If not as specified, replace the rear antenna feeder.

○—○ : Continuity

Step	Terminal			
	A	B	C	D
1	○—		○—	
2		○—		○—

Y3A8124W002

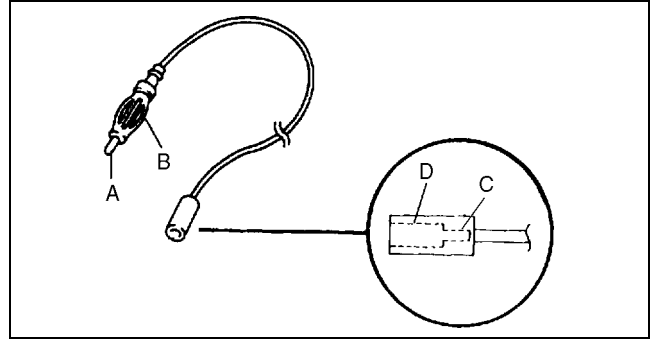

A3U0920W101

## AUDIO UNIT REMOVAL

A3U092066900W01

1. Disconnect the negative battery cable.
2. Remove the hole covers by inserting a small tape-wrapped screwdriver into the slot and carefully pry them off without scratching the center panel. Pry up and pull off the hole covers carefully to prevent the posts from breaking off.
3. With the beveled parts of the **SST** facing inward, insert them into the unit.

### Note

- Two sets of the **SSTs** are necessary to remove the audio unit.

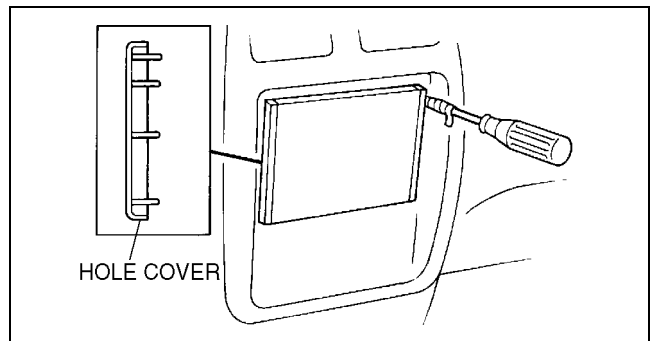

YDE81241201

4. Pull the **SST** outward and forward to slide out the unit.
5. Disconnect the connectors and antenna jack.

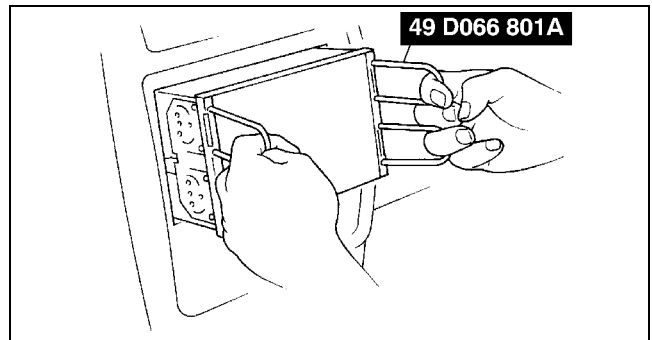

YDJ8124W107

## AUDIO UNIT INSTALLATION

A3U092066900W02

### Caution

- Make certain that the wiring harness and antenna feeder are not caught between the unit and dashboard. If the harness or the antenna feeder is caught between the unit and dashboard, it may become the cause of trouble or malfunctions.

1. Connect the connectors and antenna jack.
2. Insert the unit until each clip clicks into place.

### Caution

- To install audio unit, be sure to push service hole cover areas on both sides of the audio unit. If switches are pressed instead, it may become the cause of trouble or malfunctions.

3. Install the service hole covers.
4. Connect the negative battery cable.

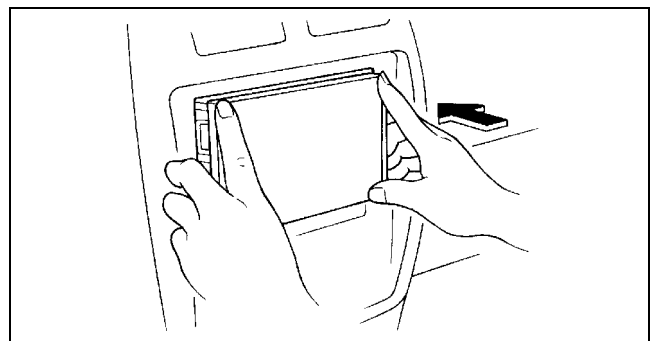

YDJ8124W108



## UPPER MODULE REMOVAL/INSTALLATION

1. Disconnect the negative battery cable.
2. Remove the audio unit. (See 09–20–6 AUDIO UNIT REMOVAL.)
3. Remove in the order indicated in the table.

1	Screw (See 09–20–7 Screw Installation Note)
2	Upper module (See 09–20–7 Upper Module Removal Note)
3	Cover (See 09–20–7 Cover Removal Note)

4. Install in the reverse order of removal.

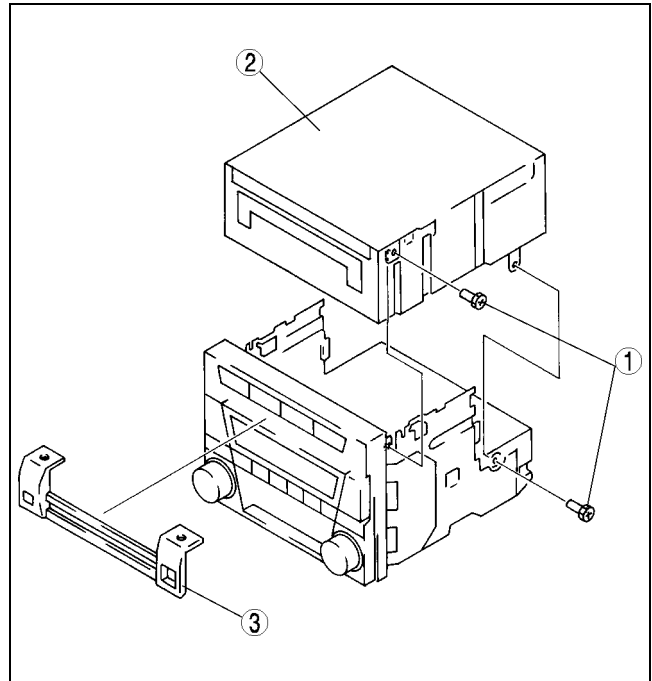

Y5J8124W004

### Upper Module Removal Note

1. Insert a screwdriver into the hole stamped mark.
2. To remove upper module, lift it by pushing down the screwdriver's handle.

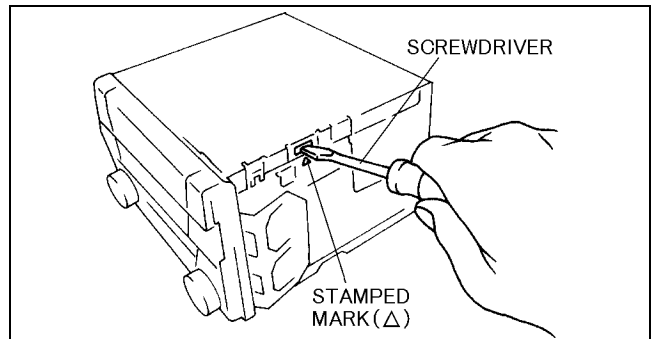

YLE8124W005

### Cover Removal Note

1. Insert a tape-wrapped screwdriver between the cover and the base unit, then unlatch hook A.
2. To unlatch hook B, pull the cover upward.

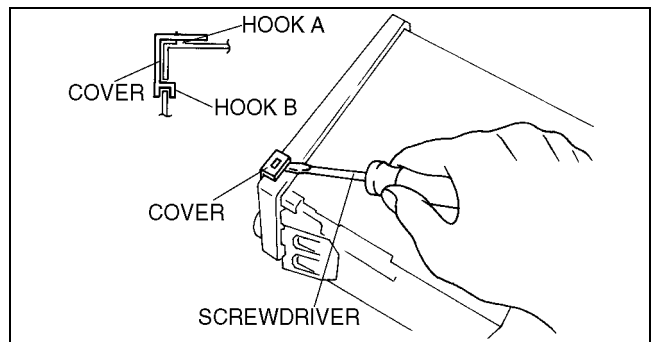

YLE8124W006

### Screw Installation Note

#### Caution

- If an undesignated screw is used, the inside of the upper module could be damaged. When installing the module, be sure to use a designated screw (red).

# ENTERTAINMENT

A3U092066900W04

## LOWER MODULE REMOVAL/INSTALLATION

1. Disconnect the negative battery cable.
2. Remove the audio unit. (See 09-20-6 AUDIO UNIT REMOVAL.)
3. Remove in the order indicated in the table.

1	Cover (See 09-20-8 Cover Removal Note)
2	Screw (See 09-20-8 Screw Installation Note)
3	Lower module

4. Install in the reverse order of removal.

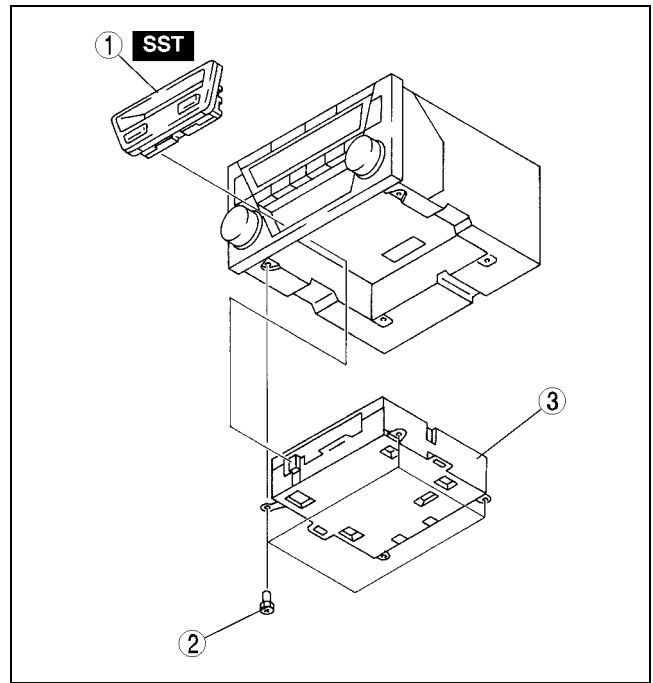

YLE8124W007

### Cover Removal Note

1. Insert the **SST** into the service holes on the bottom surface of the lower module.
2. To remove the cover, push the **SST** in the direction shown by the arrow.

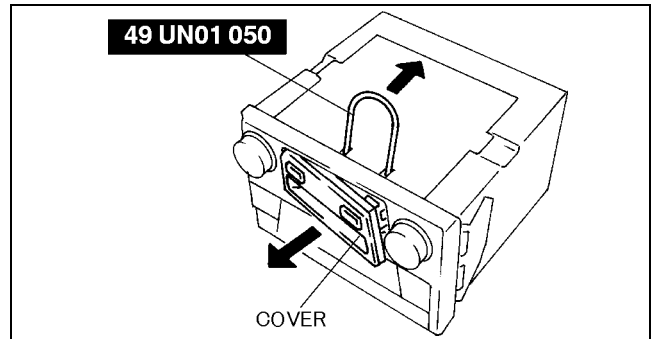

ZLU0920W003

### Screw Installation Note

#### Caution

- If an undesignated screw is used, the inside of the upper module could be damaged. When installing the module, be sure to use a designated screw (red).

## CIGARETTE LIGHTER REMOVAL/INSTALLATION

1. Disconnect the negative battery cable.
2. Remove the console. (See 09-17-5 CONSOLE REMOVAL/INSTALLATION.)
3. Remove in the order indicated in the table.

1	Cigarette lighter plug
2	Connector
3	Socket (See 09-20-9 Socket Removal Note)
4	Ring (See 09-20-9 Ring Removal Note)

4. Install in the reverse order of removal.

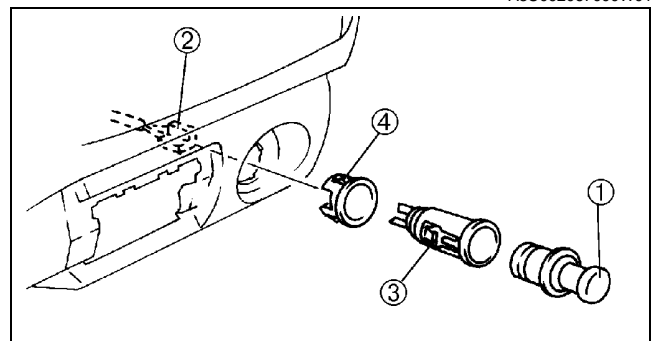

A3U092067000W01

X3U920WAG

## Socket Removal Note

1. Turn the socket while pushing the protrusion of the ring through the hole of the socket with a tape-wrapped screwdriver.
2. Push the socket forward.

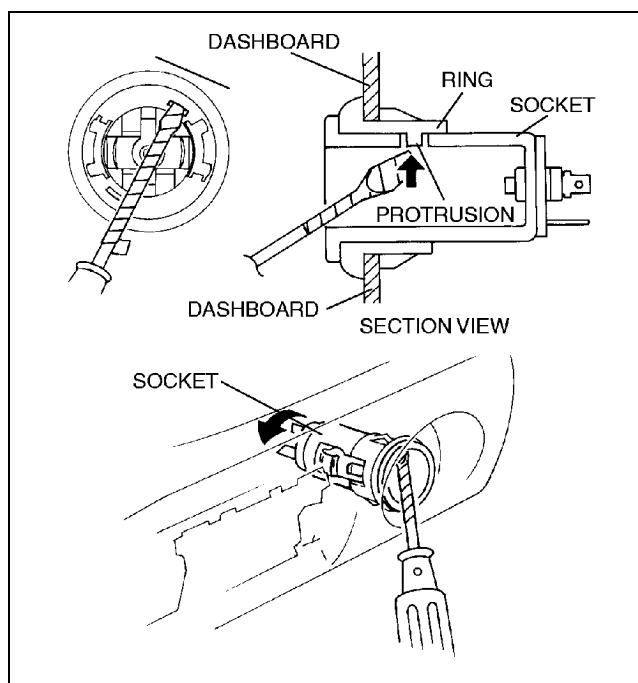

X3U920WAH

3. Return the socket clockwise to original angle position as shown to pull it out forward.

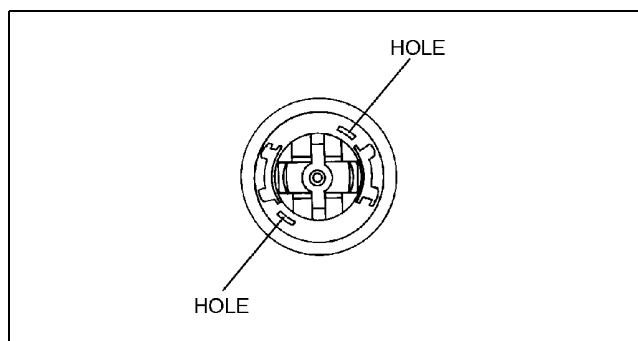

X3U920WAJ

09-20

## Ring Removal Note

1. Pull the ring forward while pushing the tabs.

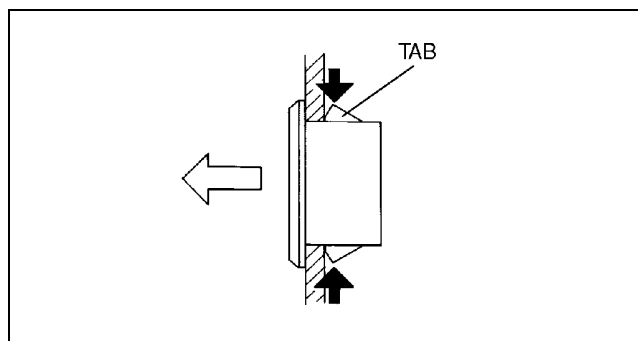

Y3U920WA3

## CIGARETTE LIGHTER INSPECTION

A3U092067000W02

1. Turn the ignition switch to ACC position.
2. Verify that the cigarette lighter plug will move normally within **10—20 seconds**, after pressing the plug into the socket.
  - If the cigarette lighter does not operate normally, replace the cigarette lighter and socket. (See 09-20-8 CIGARETTE LIGHTER REMOVAL/INSTALLATION.)

# 09-21 POWER SYSTEMS

LOCATION INDEX ..... 09-21-1  
 FUSE SERVICE CAUTION ..... 09-21-2  
 MAIN FUSE REMOVAL/INSTALLATION 09-21-2  
 ROOM FUSE INSTALLATION ..... 09-21-3  
 FUSE BLOCK  
 REMOVAL/INSTALLATION ..... 09-21-3  
 IGNITION SWITCH  
 REMOVAL/INSTALLATION ..... 09-21-3  
 IGNITION SWITCH INSPECTION..... 09-21-4

KEY REMINDER SWITCH  
 REMOVAL/INSTALLATION.....09-21-4  
 KEY REMINDER SWITCH  
 INSPECTION .....09-21-4  
 RELAY INSPECTION.....09-21-5  
 Relay type .....09-21-5  
 Four-terminal .....09-21-5  
 Five-terminal .....09-21-6  
 Eight-terminal .....09-21-7

## LOCATION INDEX

A3U092101072W01

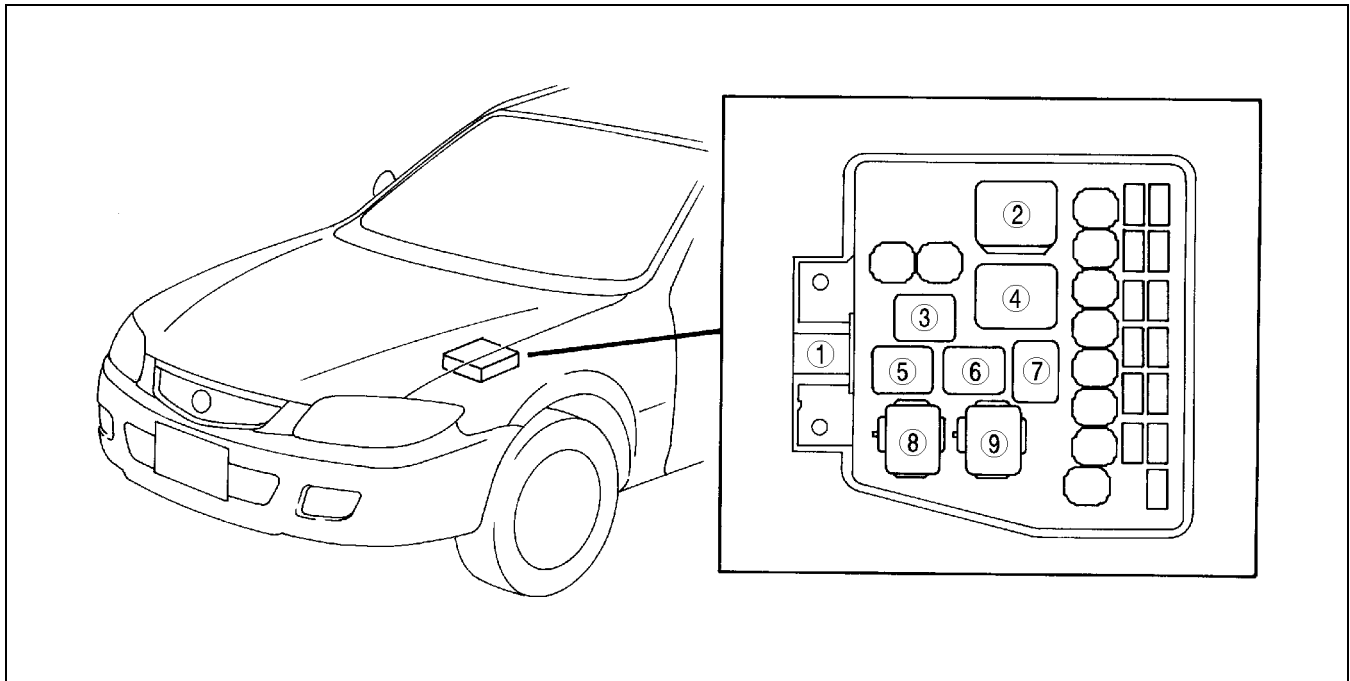

Z3U0921W007

1	Main fuse (See 09-21-2 MAIN FUSE REMOVAL/ INSTALLATION)
2	Fuel pump relay (See 09-21-5 RELAY INSPECTION)
3	A/C relay (See 09-21-5 RELAY INSPECTION)
4	Main relay (See 09-21-5 RELAY INSPECTION)

5	TNS relay (See 09-21-5 RELAY INSPECTION)
6	Horn relay (See 09-21-5 RELAY INSPECTION)
7	Headlight relay (See 09-21-5 RELAY INSPECTION)
8	Cooling fan relay (See 09-21-5 RELAY INSPECTION)
9	Condenser fan relay (See 09-21-5 RELAY INSPECTION)

09-21

# POWER SYSTEMS

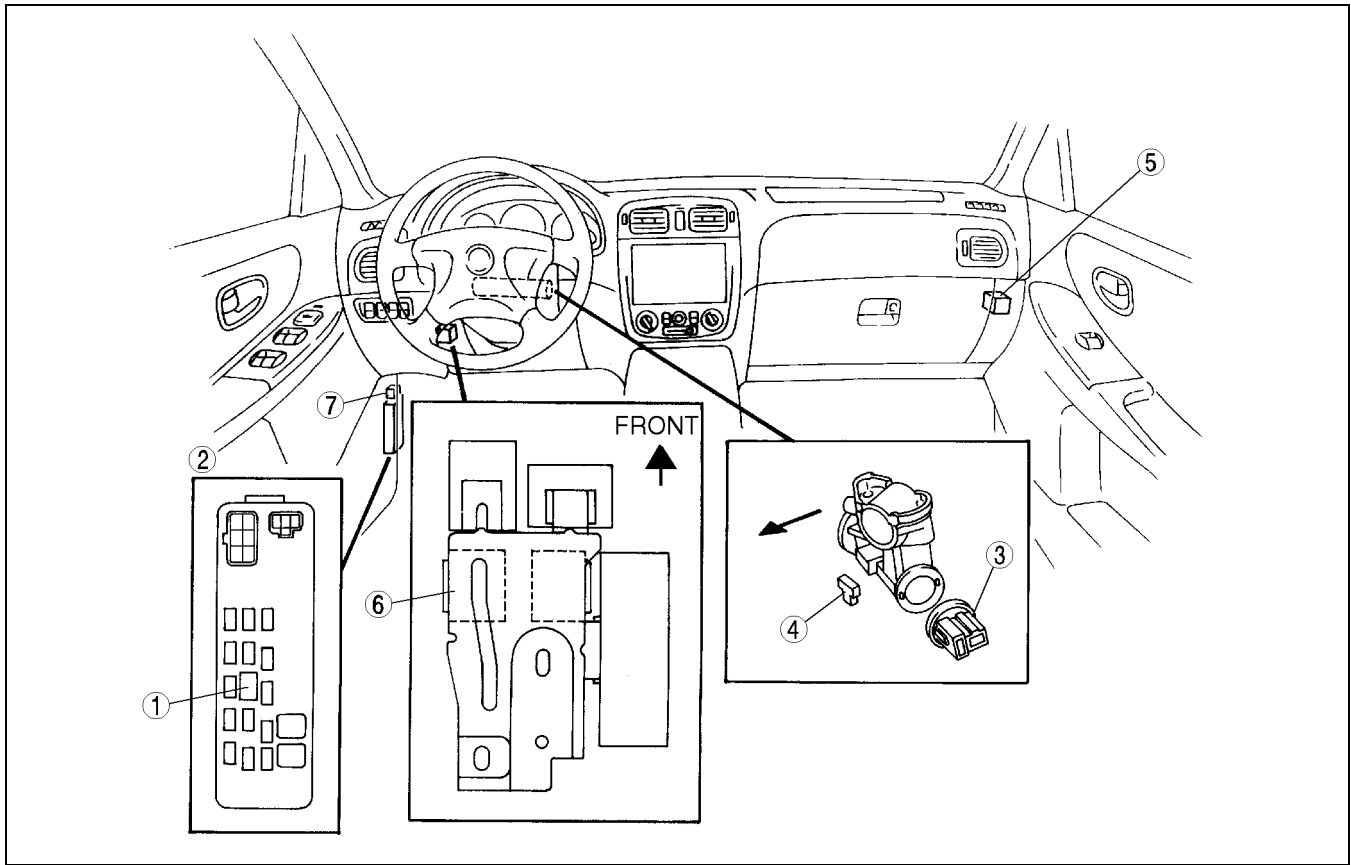

Z3U0921W008

1	Room fuse (See 09-21-3 ROOM FUSE INSTALLATION)
2	Fuse block (See 09-21-3 FUSE BLOCK REMOVAL/ INSTALLATION)
3	Ignition switch (See 09-21-3 IGNITION SWITCH REMOVAL/ INSTALLATION) (See 09-21-4 IGNITION SWITCH INSPECTION)

4	Key reminder switch (See 09-21-4 KEY REMINDER SWITCH REMOVAL/INSTALLATION) (See 09-21-4 KEY REMINDER SWITCH INSPECTION)
5	Blower relay (See 09-21-5 RELAY INSPECTION)
6	Front fog light relay (See 09-21-5 RELAY INSPECTION)
7	Rear window defroster relay (See 09-21-5 RELAY INSPECTION)

## FUSE SERVICE CAUTION

A3U092166000W01

### Caution

- Determine and correct the cause of the burnt fuse before replacing it with the specified type. If the fuse is replaced before doing this, it may burn again.

## MAIN FUSE REMOVAL/INSTALLATION

A3U092166761W01

1. Disconnect the negative battery cable.
2. Remove the main fuse block cover.
3. Remove in the order indicated in the table.

1	Nut
2	Bolt
3	Main fuse

4. Install in the reverse order of removal.

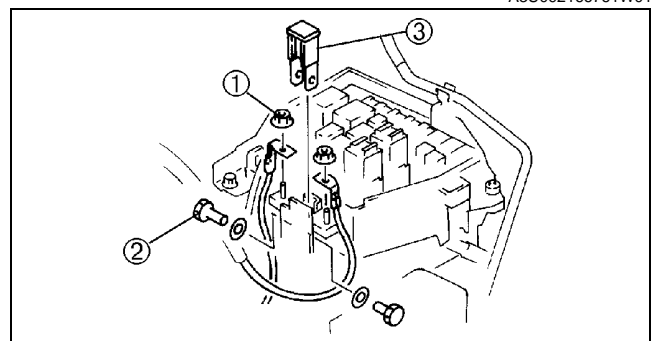

X3U921WA0

## ROOM FUSE INSTALLATION

A3U092166731W01

### Note

- When the ROOM fuse is burnt or removed, the malfunction indicator lamp illuminates. If the ROOM fuse is replaced or installed with the ignition switch at ON position, the malfunction indicator lamp will continue to illuminate.

1. Turn the ignition switch to LOCK position.
2. Install the ROOM 10 A fuse.

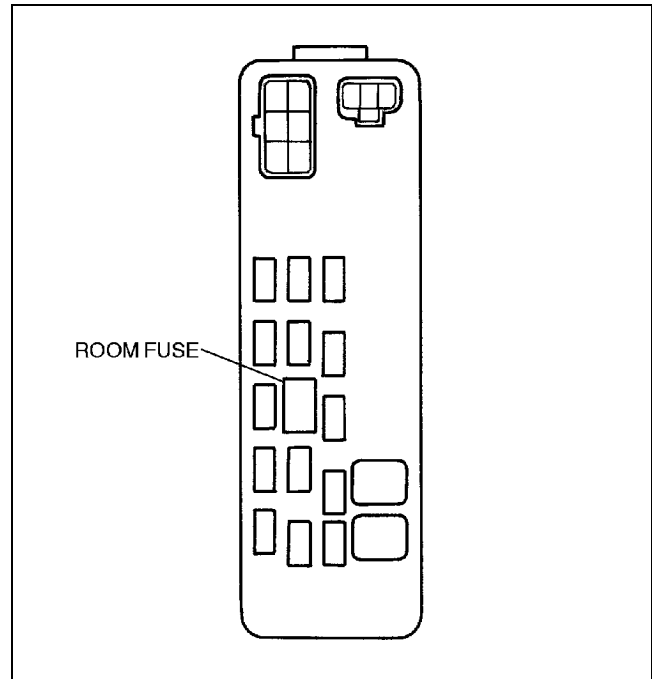

X3U921WA1

09-21

## FUSE BLOCK REMOVAL/INSTALLATION

A3U092166730W01

1. Disconnect the negative battery cable.
2. Remove the driver-side front side trim. (See 09-17-13 FRONT SIDE TRIM REMOVAL/INSTALLATION.)
3. Remove in the order indicated in the table.

1	Bolt
2	Screw
3	Connector
4	Fuse block

4. Install in the reverse order of removal.

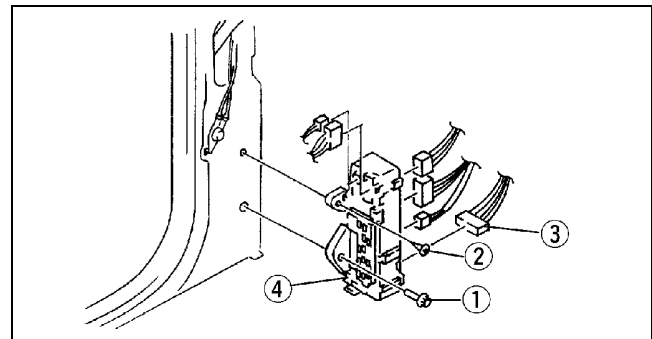

X3U921WA8

## IGNITION SWITCH REMOVAL/INSTALLATION

A3U092166151W01

1. Disconnect the negative battery cable.
2. Remove the column cover.
3. Remove in the order indicated in the table.

1	Connector
2	Screw
3	Ignition switch

4. Install in the reverse order of removal.

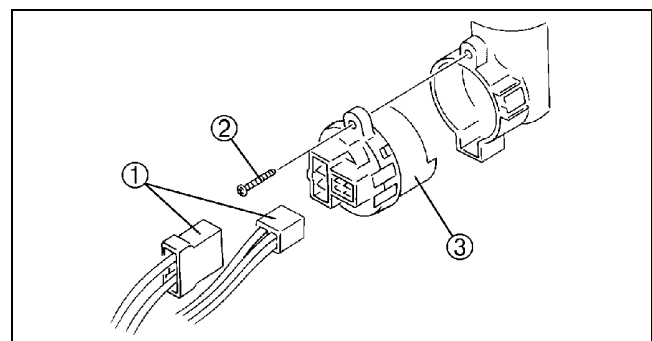

X3U921WA2

# POWER SYSTEMS

## IGNITION SWITCH INSPECTION

A3U092166151W02

1. Disconnect the negative battery cable.
2. Remove the column cover.
3. Disconnect the ignition switch connectors.
4. Inspect for continuity between the ignition switch terminals using an ohmmeter.
  - If not as specified, replace the ignition switch.

○—○ : Continuity

Ignition key position	Terminal					
	2A	2B	1D	1C	1B	1A
LOCK						
ACC	○—○		○—○			
ON	○—○	○—○	○—○	○—○	○—○	
START	○—○	○—○		○—○		○—○

X3U921WA3

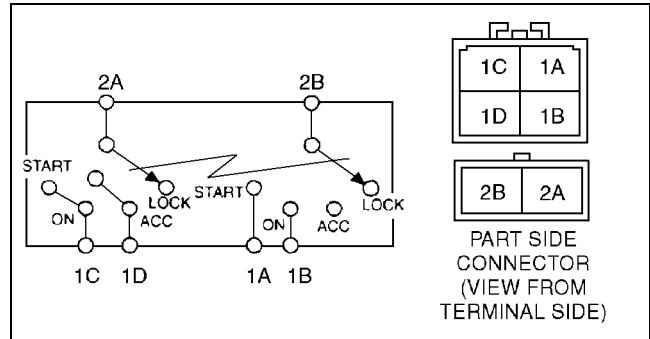

Z3U0921W001

## KEY REMINDER SWITCH REMOVAL/INSTALLATION

A3U092166152W01

1. Disconnect the negative battery cable.
2. Remove the column cover.
3. Disconnect the key reminder switch connector.
4. Remove the key reminder switch.
5. Install in the reverse order of removal.

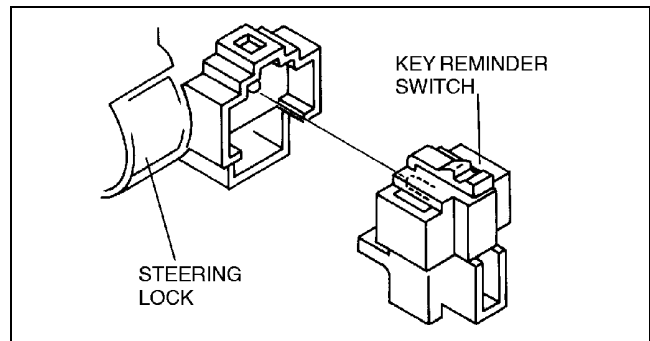

X3U921WA5

## KEY REMINDER SWITCH INSPECTION

A3U092166152W02

1. Disconnect the negative battery cable.
2. Remove the column cover.
3. Disconnect the key reminder switch connector.
4. Inspect for continuity between the key reminder switch terminals using an ohmmeter.
  - If not as specified, replace the key reminder switch.

○—○ : Continuity

Key position	Terminal	
	A	B
key inserted	○—○	○—○
key removed		

X3U921WA6

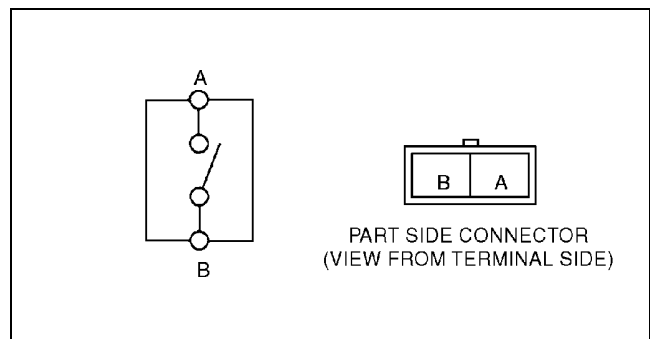

Y3U921WA1

## RELAY INSPECTION

A3U092167742W01

### Relay type

Terminal type		Parts name
Four-terminal	Type A	<ul style="list-style-type: none"> <li>• Front fog light relay</li> <li>• A/C relay</li> <li>• Condenser fan relay No.1</li> <li>• Condenser fan relay No.2</li> <li>• Cooling fan relay No.2 (KJ)</li> <li>• Cooling fan relay No.3 (KJ)</li> <li>• Rear window defroster relay</li> <li>• TNS relay</li> <li>• Woofer relay</li> <li>• Trunk lid opener relay</li> <li>• Seat warmer relay</li> <li>• Power window relay</li> <li>• Main relay</li> </ul>
	Type B	<ul style="list-style-type: none"> <li>• Horn relay</li> </ul>
	Type C	<ul style="list-style-type: none"> <li>• Starter cut relay</li> </ul>
	Type D	<ul style="list-style-type: none"> <li>• Fuel pump relay</li> </ul>
Five-terminal	Type A	<ul style="list-style-type: none"> <li>• DRL relay</li> <li>• Cooling fan relay (KL)</li> <li>• Cooling fan relay No.1 (KJ)</li> </ul>
	Type B	<ul style="list-style-type: none"> <li>• Headlight relay</li> <li>• Blower relay</li> </ul>
Eight-terminal		<ul style="list-style-type: none"> <li>• Sunroof relay</li> </ul>

### Four-terminal

#### Type A

1. Remove the relay.
2. Inspect for continuity between the relay terminals using an ohmmeter.
  - If not as specified, replace the relay.

○—○: Continuity

Step	Terminal			
	A	B	C	D
1	○—○			
2	B+	GND	○—○	

ZLU0921W004

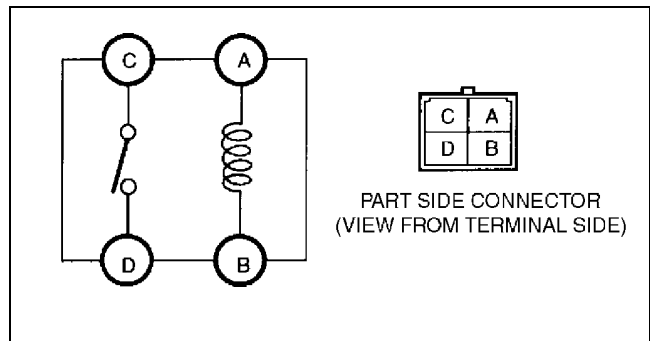

ZLU0921W003

#### Type B

1. Remove the relay.
2. Inspect for continuity between the relay terminals using an ohmmeter.
  - If not as specified, replace the relay.

○—○: Continuity

Step	Terminal			
	D	B	A	C
1	○—○			
2	GND	B+	○—○	

ZLU0921W002

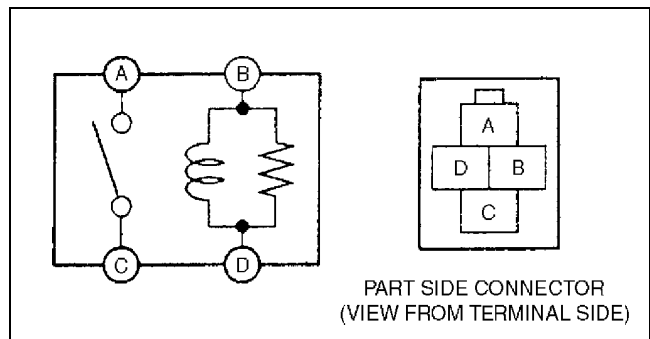

ZLU0921W001



# POWER SYSTEMS

## Type C

1. Remove the relay.
2. Inspect for continuity between the relay terminals using an ohmmeter.
  - If not as specified, replace the relay.

○—○: Continuity

Step	Terminal			
	A	B	C	F
1	○—○	○—○	○—○	○—○
2	B+	GND		

ZLU0921W006

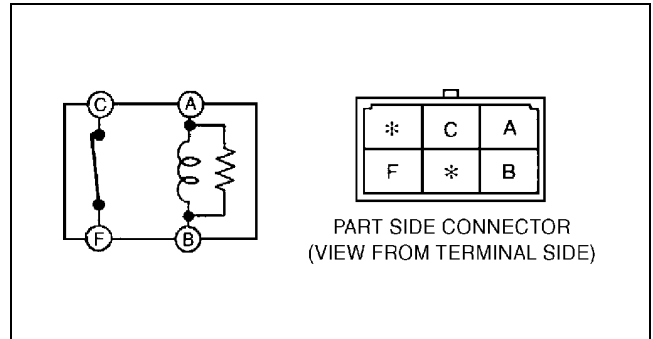

ZLU0921W005

## Type D

1. Remove the relay.
2. Inspect for continuity between the relay terminals using an ohmmeter.
  - If not as specified, replace the relay.

○—○: Continuity

Step	Terminal			
	A	B	C	D
1	○—○	○—○		
2	B+	GND	○—○	○—○

ZLU0921W007

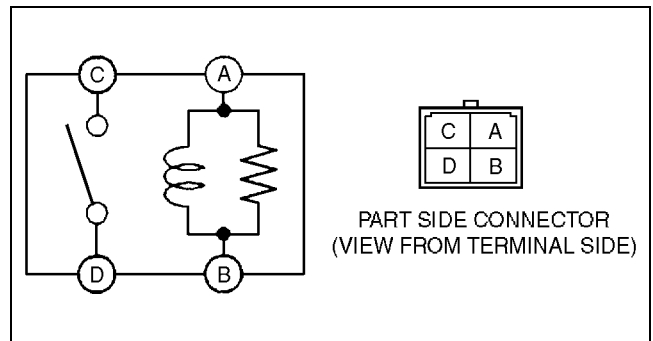

ZLU0921WA0

## Five-terminal

### Type A

1. Remove the relay.
2. Inspect for continuity between the relay terminals using an ohmmeter.
  - If not as specified, replace the relay.

○—○: Continuity

Step	Terminal				
	A	B	E	C	F
1	○—○	○—○		○—○	○—○
2	GND	B+	○—○	○—○	

ZLU0921W009

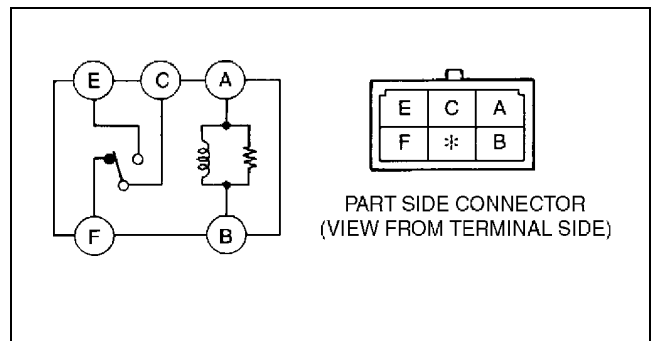

ZLU0921W008

# POWER SYSTEMS

## Type B

1. Remove the relay.
2. Inspect for continuity between the relay terminals using an ohmmeter.
  - If not as specified, replace the relay.

○—○: Continuity

Step	Terminal			
	A	E	B	F
1	○—○	○—○		
2	GND	B+	○—○	○—○

ZLU0921W011

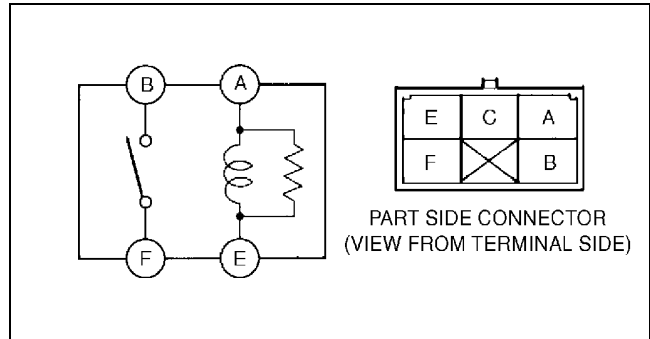

ZLU0921W010

## Eight-terminal

1. Remove the relay.
2. Inspect for continuity between the relay terminals using an ohmmeter.
  - If not as specified, replace the relay.

○—○: Continuity

Connection		Terminal			
B+	GND	A	D	G	I
—	—	○—○	○—○		○—○
H	J	○—○	○—○	○—○	○—○
F	B	○—○	○—○	○—○	○—○

ZLU0921W013

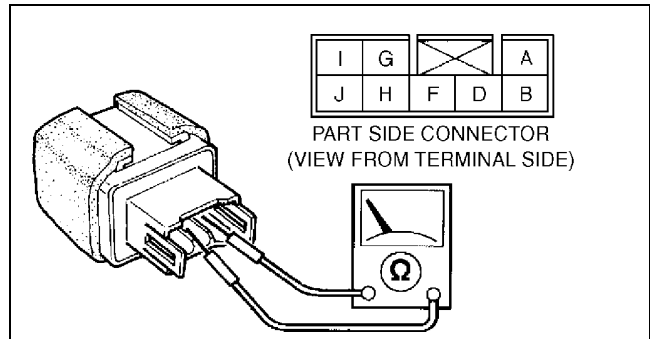

ZLU0921W012

**09-22 INSTRUMENTATION/DRIVER INFO.**

LOCATION INDEX ..... 09-22-1  
**INSTRUMENT CLUSTER SYSTEM**  
 WIRING DIAGRAM ..... 09-22-2  
**INSTRUMENT CLUSTER**  
 REMOVAL/INSTALLATION ..... 09-22-3  
 Instrument Cluster Removal Note .... 09-22-3  
**INSTRUMENT CLUSTER**  
 DISASSEMBLY/ASSEMBLY ..... 09-22-3  
**INSTRUMENT CLUSTER INSPECTION.** 09-22-4  
 Speedometer ..... 09-22-4  
 Tachometer ..... 09-22-4  
 Fuel Gauge ..... 09-22-4  
 Water Temperature Gauge ..... 09-22-4

**INSTRUMENT CLUSTER REPAIR** .....09-22-4  
 Tachometer.....09-22-4  
**INSTRUMENT CLUSTER INPUT/OUTPUT**  
**CHECK MODE** .....09-22-5  
 DTC Chart.....09-22-5  
 Operating Order .....09-22-6  
 Checking Order .....09-22-7  
 Inspection of DTCs .....09-22-7  
**WARNING AND INDICATOR LIGHT BULB**  
**REMOVAL/INSTALLATION.**.....09-22-13  
**FUEL GAUGE SENDER UNIT**  
**INSPECTION** .....09-22-13  
**OIL PRESSURE SWITCH**  
**INSPECTION** .....09-22-13  
**HORN REMOVAL/INSTALLATION** ..... 09-22-13

**LOCATION INDEX**

A3U092201067W01

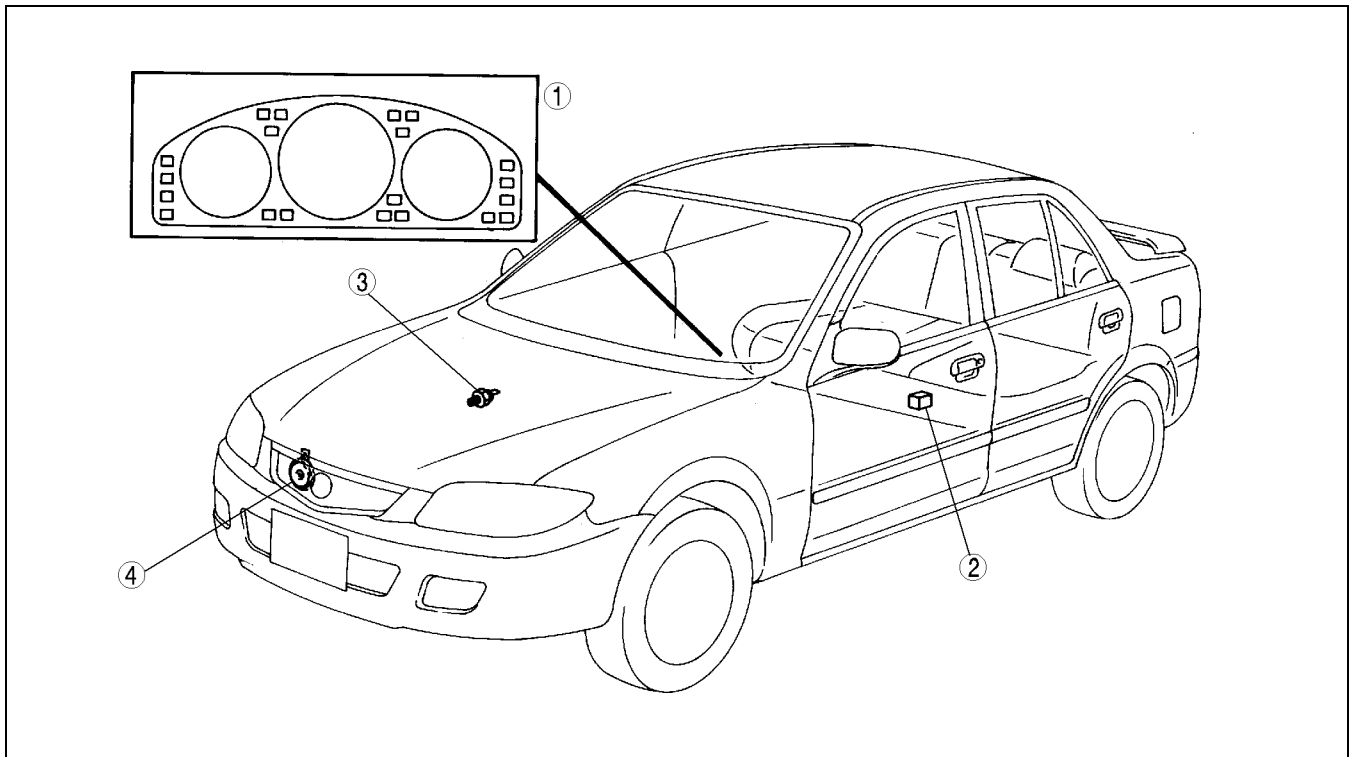

09-22

Z3U0922W003

1	Instrument cluster (See 09-22-3 INSTRUMENT CLUSTER REMOVAL/INSTALLATION) (See 09-22-3 INSTRUMENT CLUSTER DISASSEMBLY/ASSEMBLY) (See 09-22-4 INSTRUMENT CLUSTER INSPECTION) (See 09-22-4 INSTRUMENT CLUSTER REPAIR) (See 09-22-5 INSTRUMENT CLUSTER INPUT/ OUTPUT CHECK MODE) (See 09-22-13 WARNING AND INDICATOR LIGHT BULB REMOVAL/INSTALLATION)
---	--

2	Fuel gauge sender unit (See 09-22-13 FUEL GAUGE SENDER UNIT INSPECTION)
3	Oil pressure switch (See 09-22-13 OIL PRESSURE SWITCH INSPECTION)
4	Horn (See 09-22-13 HORN REMOVAL/INSTALLATION)

# INSTRUMENTATION/DRIVER INFO.

## INSTRUMENT CLUSTER SYSTEM WIRING DIAGRAM

A3U092255430W01

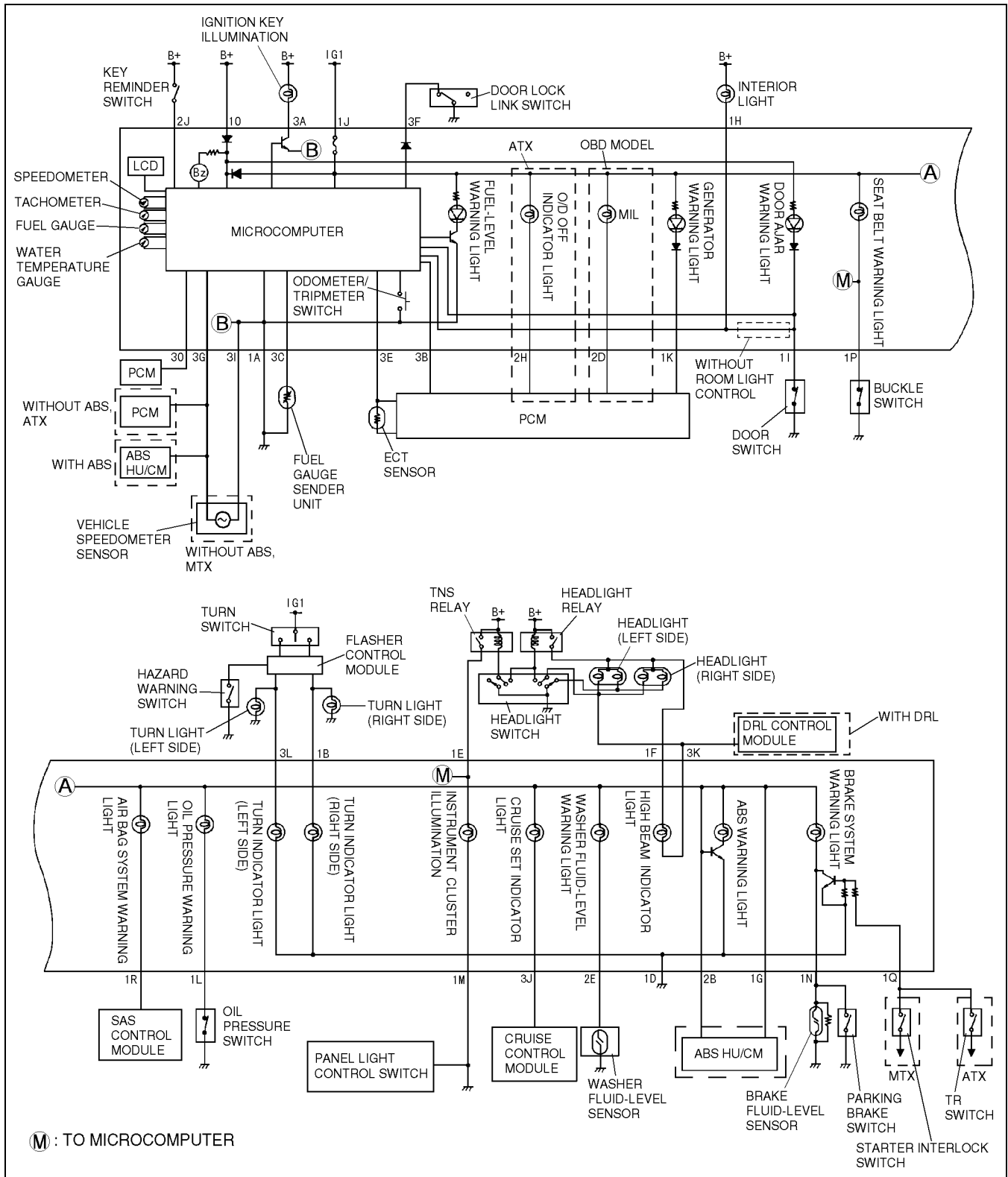

Z3U0922W005

# INSTRUMENTATION/DRIVER INFO.

## INSTRUMENT CLUSTER REMOVAL/INSTALLATION

A3U092255430W02

1. Disconnect the negative battery cable.
2. Pull down the adjusting lever of the tilt steering wheel and push the steering wheel down.
3. Remove the meter hood.
4. Remove in the order indicated in the table.

1	Screw
2	Connector
3	Instrument cluster (See 09-22-3 Instrument Cluster Removal Note)

5. Install in the reverse order of removal.

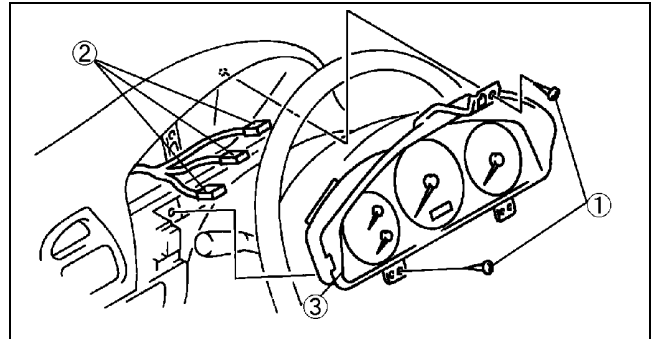

X3U922WA0

### Instrument Cluster Removal Note

1. When removing the instrument cluster, in order to prevent damage to the lens, cover the steering shaft with a cloth.

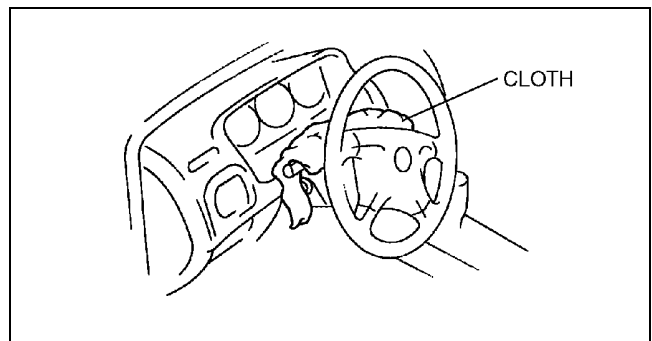

X3U922WA1

09-22

## INSTRUMENT CLUSTER DISASSEMBLY/ASSEMBLY

A3U092255430W03

### Caution

- If the instrument cluster is dropped or the print plate is damaged, the system will not operate properly and it may become the cause of trouble or malfunctions.

1. Disassemble in the order indicated in the table.

1	Screw
2	Bracket
3	Lens
4	Bulb
5	Screw
6	Cover
7	Screw
8	Instrument cluster
9	Case

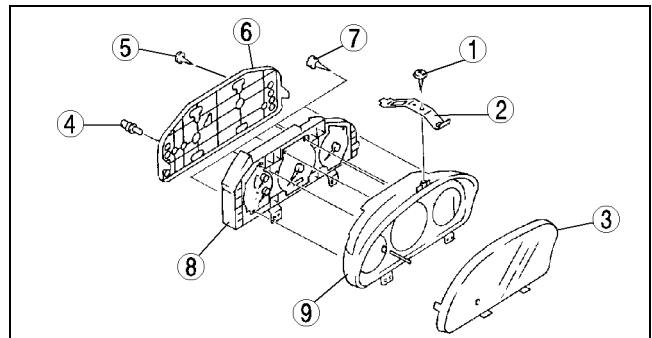

Z3U0922W001

2. Assemble in the reverse order of disassembly.

# INSTRUMENTATION/DRIVER INFO.

## INSTRUMENT CLUSTER INSPECTION

A3U092255430W04

### Speedometer

1. Inspect the speedometer by setting it in the input/output check mode DTC 12. (See 09-22-5 INSTRUMENT CLUSTER INPUT/OUTPUT CHECK MODE.)

### Tachometer

1. Inspect the tachometer by setting it in the input/output check mode DTC 13. (See 09-22-5 INSTRUMENT CLUSTER INPUT/OUTPUT CHECK MODE.)

### Fuel Gauge

1. Inspect the fuel gauge by setting it in the input/output check mode DTC 23. (See 09-22-5 INSTRUMENT CLUSTER INPUT/OUTPUT CHECK MODE.)

### Water Temperature Gauge

1. Inspect the water temperature gauge by setting it in the input/output check mode DTC 25. (See 09-22-5 INSTRUMENT CLUSTER INPUT/OUTPUT CHECK MODE.)

## INSTRUMENT CLUSTER REPAIR

A3U092255430W05

### Tachometer

#### Note

- The tach needle will not return to zero if the engine is turned off while the engine speed is **4,000 rpm** or higher when the ROOM fuse is not installed. The tach needle will continue to rotate clockwise until it rests on the wrong side of the stopper pin. If a customer complains of this concern, inspect the ROOM fuse and if necessary, repair according to the following steps.

1. Verify the concern.
2. Verify that the ROOM fuse is installed.

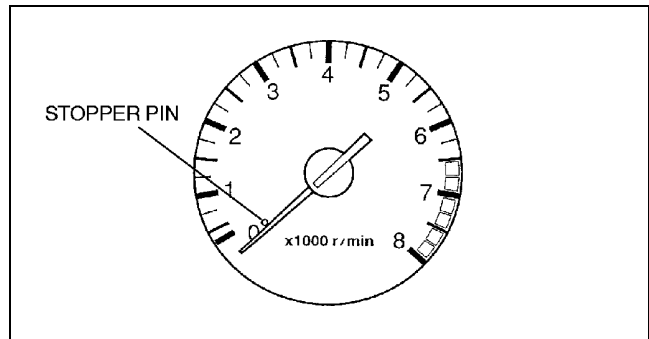

X3U922WC0

3. Start the engine and increase the engine speed to **approximately 5,500 rpm** or until the needle begins to move away from the stopper pin (counterclockwise).
4. Decrease the engine speed to idle and turn the ignition switch to LOCK position.
5. Verify that the needle returns to zero.
  - If the needle does not return to zero, remove the lens and carefully move the needle by hand.

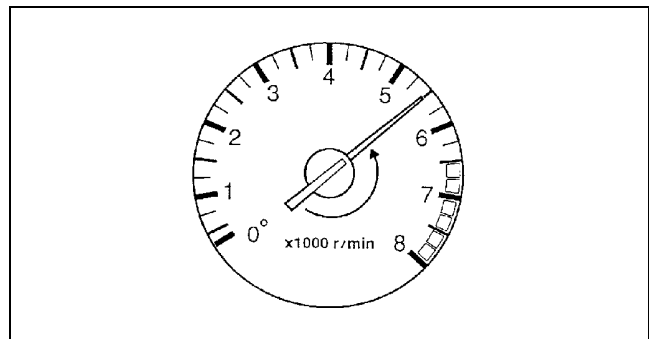

X3U922WC1

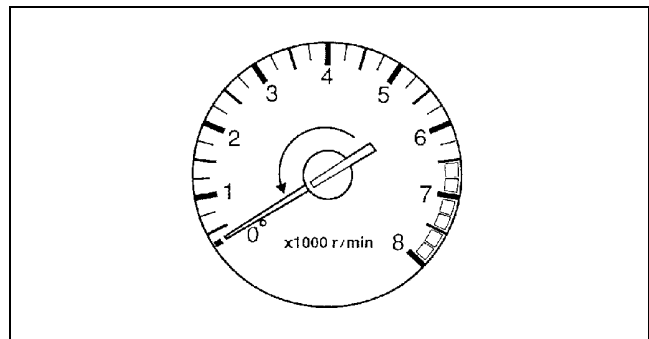

X3U922WC2

## INSTRUMENTATION/DRIVER INFO.

### INSTRUMENT CLUSTER INPUT/OUTPUT CHECK MODE

A3U092255430W06

**Note**

- In this mode, it is possible to check the items in the following chart.

**DTC Chart**

DTC	Checking item	Related item
01	Buckle switch	Buckle switch
04	Door switch	<ul style="list-style-type: none"> <li>• Ignition key illumination</li> <li>• Room light control</li> <li>• Power door lock system</li> <li>• Lights-on reminder warning buzzer</li> </ul>
05	Door lock-link switch	Room light control
08	TNS relay	<ul style="list-style-type: none"> <li>• Lights-on reminder warning buzzer</li> <li>• Each illumination</li> </ul>
10	<p><b>With ABS</b></p> <ul style="list-style-type: none"> <li>• ABS HU/CM (vehicle speed signal)</li> </ul> <p><b>Without ABS, MTX</b></p> <ul style="list-style-type: none"> <li>• Vehicle speedometer sensor (vehicle speed signal)</li> </ul> <p><b>Without ABS, ATX</b></p> <ul style="list-style-type: none"> <li>• PCM (vehicle speed signal)</li> </ul>	Speedometer
11	PCM (engine speed signal)	Tachometer
12	Speedometer	Speedometer
13	Tachometer	Tachometer
14	Buzzer	<ul style="list-style-type: none"> <li>• Lights-on reminder warning buzzer</li> <li>• Key reminder warning buzzer</li> </ul>
16	Fuel-level warning light	Fuel-level warning light
22	Fuel gauge sender unit	Fuel gauge
23	Fuel gauge	Fuel gauge
24	ECT sensor	Water temperature gauge
25	Water temperature gauge	Water temperature gauge
26	LCD	LCD
27	Interior light	Room light control
31	Key reminder switch	<ul style="list-style-type: none"> <li>• Room light control</li> <li>• Keyless entry system</li> </ul>

09-22

**Note**

- The diagnostic trouble codes are displayed in numerical order. (While performing the inspection, if you want to inspect a diagnostic trouble code number which is smaller than the code number you are currently inspecting, terminate the check mode then repeat the inspection from the beginning.)
- If the speed signal is put into the instrument cluster (the front wheels are rotated) while a code other than DTC 10 is displayed, the input/output check mode will be cancelled.
- The diagnostic trouble codes can be fast-forwarded by pushing and holding the odometer/tripmeter switch for **1 second or more**.

# INSTRUMENTATION/DRIVER INFO.

## Operating Order

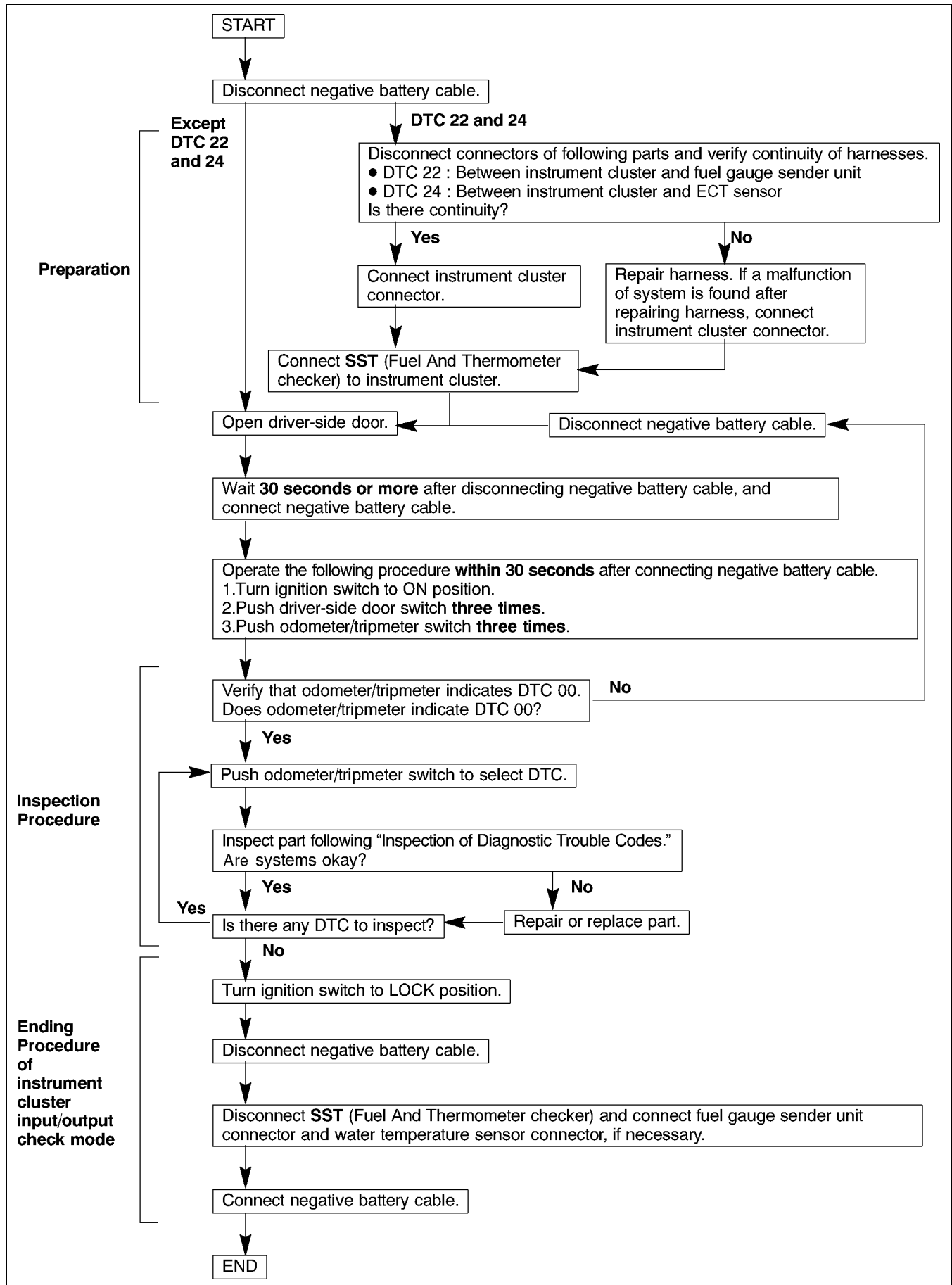

Z3U0922W002



## INSTRUMENTATION/DRIVER INFO.

### Checking Order

#### Note

- When inspecting more than two check codes, perform the inspection by following the priority order of inspection indicated in the chart below.

Priority order of inspection	IG switch position	Check code
1	ON	22, 24
2		01, 04, 05, 08, 10, 11, 12, 13, 14, 16, 23, 25, 26, 27
3	LOCK	31

### Inspection of DTCs

DTC 01 Buckle switch on/off signal			
STEP	INSPECTION	INDICATION	ACTION
1	Unfasten driver-side seat belt. (Buckle switch on.)	ON	Go to next step.
		OFF	<ul style="list-style-type: none"> <li>Inspect buckle switch. (See 08–11–5 BUCKLE SWITCH INSPECTION)</li> <li>Inspect wiring harness. (Instrument cluster — buckle switch)</li> </ul>
2	Fasten driver-side seat belt. (Buckle switch off.)	ON	<ul style="list-style-type: none"> <li>Inspect buckle switch. (See 08–11–5 BUCKLE SWITCH INSPECTION)</li> <li>Inspect wiring harness. (Instrument cluster — buckle switch)</li> </ul>
		OFF	Input signal to instrument cluster is okay.

09–22

DTC 04 Door switch on/off signal			
STEP	INSPECTION	INDICATION	ACTION
1	Open driver-side door. (Door switch on.)	ON	Close driver-side door, then go to next step.
		OFF	<ul style="list-style-type: none"> <li>Inspect door switch. (See 09–18–25 DOOR SWITCH INSPECTION)</li> <li>Inspect wiring harness. (Instrument cluster — door switch)</li> </ul>
2	Open passenger-side door. (Door switch on.)	ON	Close passenger-side door, then go to next step.
		OFF	<ul style="list-style-type: none"> <li>Inspect door switch. (See 09–18–25 DOOR SWITCH INSPECTION)</li> <li>Inspect wiring harness. (Instrument cluster — door switch)</li> </ul>
3	Open rear door on driver-side. (Door switch on.)	ON	Close rear door on driver-side, then go to next step.
		OFF	<ul style="list-style-type: none"> <li>Inspect door switch. (See 09–18–25 DOOR SWITCH INSPECTION)</li> <li>Inspect wiring harness. (Instrument cluster — door switch)</li> </ul>

## INSTRUMENTATION/DRIVER INFO.

<b>DTC 04 Door switch on/off signal</b>			
<b>STEP</b>	<b>INSPECTION</b>	<b>INDICATION</b>	<b>ACTION</b>
4	Open rear door on passenger-side. (Door switch on.)	ON	Close rear door on passenger-side, then go to next step.
		OFF	<ul style="list-style-type: none"> <li>Inspect door switch. (See 09-18-25 DOOR SWITCH INSPECTION)</li> <li>Inspect wiring harness. (Instrument cluster — door switch)</li> </ul>
5	Close all doors. (Door switch off.)	ON	<ul style="list-style-type: none"> <li>Inspect door switch. (See 09-18-25 DOOR SWITCH INSPECTION)</li> <li>Inspect wiring harness. (Instrument cluster — door switch)</li> </ul>
		OFF	Input signals to instrument cluster are okay.

<b>DTC 05 Door lock-link switch on/off signal</b>			
<b>STEP</b>	<b>INSPECTION</b>	<b>INDICATION</b>	<b>ACTION</b>
1	Turn driver-side door lock knob to lock position. (Door lock-link switch to lock position.)	ON	Go to next step.
		OFF	<ul style="list-style-type: none"> <li>Inspect door lock-link switch. (See 09-14-4 DOOR LOCK-LINK SWITCH INSPECTION)</li> <li>Inspect wiring harness. (Instrument cluster — door lock-link switch — GND)</li> </ul>
2	Turn driver-side door lock knob to unlock position. (Door lock-link switch to unlock position.)	ON	<ul style="list-style-type: none"> <li>Inspect door lock-link switch. (See 09-14-4 DOOR LOCK-LINK SWITCH INSPECTION)</li> <li>Inspect wiring harness. (Instrument cluster — door lock-link switch — GND)</li> </ul>
		OFF	Input signal to instrument cluster is okay.

<b>DTC 08 TNS relay on/off signal</b>			
<b>STEP</b>	<b>INSPECTION</b>	<b>INDICATION</b>	<b>ACTION</b>
1	Turn headlight switch to TNS position. (TNS relay on.)	ON	Go to next step.
		OFF	<ul style="list-style-type: none"> <li>Inspect TNS relay. (See 09-21-5 RELAY INSPECTION)</li> <li>Inspect wiring harness. (Battery — TNS relay — instrument cluster)</li> </ul>
2	Turn headlight switch off. (TNS relay off.)	ON	<ul style="list-style-type: none"> <li>Inspect TNS relay. (See 09-21-5 RELAY INSPECTION)</li> <li>Inspect wiring harness. (TNS relay — instrument cluster)</li> </ul>
		OFF	Input signal to instrument cluster is okay.

## INSTRUMENTATION/DRIVER INFO.

DTC 10 Vehicle speed input signal		
INSPECTION	INDICATION	ACTION
Rotate drive wheels using chassis roller.	□□	Input signal to instrument cluster is okay.
	□FF	Inspect following parts <b>With ABS</b> <ul style="list-style-type: none"> <li>• ABS HU/CM</li> <li>• Wiring harness (Instrument cluster—ABS HU/CM)</li> </ul> <b>Without ABS, ATX</b> <ul style="list-style-type: none"> <li>• PCM</li> <li>• Wiring harness (Instrument cluster—PCM)</li> </ul> <b>Without ABS, MTX</b> <ul style="list-style-type: none"> <li>• Vehicle speedometer sensor</li> <li>• Wiring harness (Instrument cluster—vehicle speedometer sensor)</li> </ul>

DTC 11 Engine speed input signal		
INSPECTION	INDICATION	ACTION
Start engine.	□□	Input signal to instrument cluster is okay.
	□FF	<ul style="list-style-type: none"> <li>• Inspect PCM. (See 01-40A-7 PCM INSPECTION [ZM]) (See 01-40B-7 PCM INSPECTION [FS])</li> <li>• Inspect wiring harness. (instrument cluster — PCM)</li> </ul>

09-22



DTC 12 Operation signal to speedometer			
INSPECTION	INDICATION	SITUATION	ACTION
Wait for <b>2 seconds</b> after selecting DTC 12.	□□	Speedometer needle moves full scale then returns to <b>60 km/h {37 MPH}</b> .	Speedometer is okay.
		Other than stated above.	Replace instrument cluster.
	E r r	—	

DTC 13 Operation signal to tachometer			
INSPECTION	INDICATION	SITUATION	ACTION
Wait for <b>2 seconds</b> after selecting DTC 13.	□□	Tachometer needle moves full scale then returns to <b>3000 rpm</b> .	Tachometer is okay.
		Other than stated above.	Replace instrument cluster.
	E r r	—	

DTC 14 Operation signal to buzzer			
INSPECTION	INDICATION	SITUATION	ACTION
Wait for <b>2 seconds</b> after selecting DTC 14.	□□ (Fixed)	Buzzer continuously sounds.	Buzzer is okay.
		Buzzer does not continuously sound.	Replace instrument cluster.

## INSTRUMENTATION/DRIVER INFO.

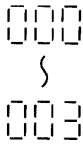
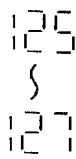
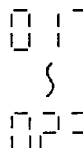
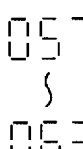
DTC 16 Operation signal to fuel-level warning light			
INSPECTION	INDICATION	SITUATION	ACTION
Wait for <b>2 seconds</b> after selecting DTC 16.	 (Turns on and off)	Fuel-level warning light turns on and off <b>3 times</b> .	Fuel-level warning light is okay.
		Other than stated above.	Inspect fuel-level warning light. (See 09-22-13 WARNING AND INDICATOR LIGHT BULB REMOVAL/ INSTALLATION)

DTC 22 Fuel level signal				
STEP	INSPECTION	INDICATION	SITUATION	ACTION
1	Select DTC 22.		Short to GND.	<ul style="list-style-type: none"> <li>• Inspect fuel gauge sender unit. (See 09-22-13 FUEL GAUGE SENDER UNIT INSPECTION)</li> <li>• Inspect wiring harness. (Instrument cluster — fuel gauge sender unit.)</li> </ul>
			Open circuit.	
		Other than stated above.	Go to next step.	
2	Using <b>SST</b> (Fuel And Thermometer checker), input <b>20 ohms</b> to terminal 3C of instrument cluster.		—	Go to next step.
		Other than stated above.	—	Replace instrument cluster.
3	Using <b>SST</b> (Fuel And Thermometer checker), input <b>60 ohms</b> to terminal 3C of instrument cluster.		—	Go to next step.
		Other than stated above.	—	Replace instrument cluster.
4	Using <b>SST</b> (Fuel And Thermometer checker), input <b>100 ohms</b> to terminal 3C of instrument cluster.		—	Input signal to instrument cluster is okay.
		Other than stated above.	—	Replace instrument cluster.

## INSTRUMENTATION/DRIVER INFO.

DTC 23		Operation signal to fuel gauge		
INSPECTION		INDICATION	SITUATION	ACTION
Wait for <b>2 seconds</b> after selecting DTC 23.		<div style="text-align: center;">□ □</div>	Fuel gauge indicates in following order for every <b>2 seconds</b> . <ul style="list-style-type: none"> <li>F→1/2→E→F (fixed)</li> </ul>	Fuel gauge is okay.
			Other than stated above.	Replace instrument cluster.
		<div style="text-align: center;">E F F</div>	Replace instrument cluster.	

DTC 24		Water temperature signal			
STEP	INSPECTION	INDICATION	SITUATION	ACTION	
1	Inspect PCM and ETC sensor. Are any DTCs of PCM displayed?	Yes	—	—	Go to applicable DTC inspection.
		No	—	—	Go to next step.
2	Select DTC 24. <b>Caution</b> • If ignition switch is turned to ON position with ECT sensor connector disconnected, DTC (P0117, P0118) of on-board diagnostic system will be recorded in PCM. After inspecting DTC 24, always delete DTC of PCM.	<div style="text-align: center;">000 } 003</div>	Short to GND.	Inspect wiring harness. (Instrument cluster — ECT sensor)	
		<div style="text-align: center;">252 } 255</div>	Open circuit.		
		Other than stated above.	—	Go to next step.	
3	Use the <b>SST</b> (Fuel and thermometer checker) to adjust the resistance so that the voltage of the instrument cluster terminal 3E is <b>approximately 0.29 V</b> .	<div style="text-align: center;">010 } 020</div>	—	Go to next step.	
		Other than stated above.	—	Replace instrument cluster.	
4	Use the <b>SST</b> (Fuel and thermometer checker) to adjust the resistance so that the voltage of the instrument cluster terminal 3E is <b>approximately 1.61V</b> .	<div style="text-align: center;">077 } 087</div>	—	Input signal to instrument cluster is okay.	
		Other than stated above.	—	Replace instrument cluster.	

## INSTRUMENTATION/DRIVER INFO.

DTC 25 Operation signal to water temperature gauge			
INSPECTION	INDICATION	SITUATION	ACTION
Wait for <b>2 seconds</b> after selecting DTC 25.	□ □	Water temperature gauge indicates in following order for every <b>2 seconds</b> . • H→Center→C→H (fixed)	Water temperature gauge is okay.
		Other than stated above.	Replace instrument cluster.
	E r r	Replace instrument cluster.	

DTC 26 LCD indication			
INSPECTION	INDICATION	SITUATION	ACTION
Wait for <b>2 seconds</b> after selecting DTC 26.	TRIP A B ODO 88888.8	Indication is normal.	LCD is okay.
		Other than stated above.	Replace instrument cluster.

DTC 27 Operation signal to interior light			
INSPECTION	INDICATION	SITUATION	ACTION
a. Turn interior light switch to DOOR position. b. Wait for <b>2 seconds</b> after selecting DTC 27.	□ □ (Turns on and off)	Interior light turns on and off <b>3 times</b> .	Interior light is okay.
		Other than stated above.	<ul style="list-style-type: none"> <li>Inspect interior light.</li> <li>Inspect wiring harness. (Battery — interior light — instrument cluster)</li> </ul>

DTC 31 TNS relay on/off signal			
STEP	INSPECTION	INDICATION	ACTION
1	Remove key from steering lock and then insert key into steering lock after selecting DTC 31 (key reminder switch on).	□ □	Go to next step.
		□ F F	<ul style="list-style-type: none"> <li>Inspect key reminder switch. (See 09-21-4 KEY REMINDER SWITCH INSPECTION)</li> <li>Inspect wiring harness. (Battery — key reminder switch — instrument cluster)</li> </ul>
2	Remove key from steering lock (key reminder switch off).	□ □	<ul style="list-style-type: none"> <li>Inspect key reminder switch. (See 09-21-4 KEY REMINDER SWITCH INSPECTION)</li> <li>Inspect wiring harness. (Battery — key reminder switch — instrument cluster)</li> </ul>
		□ F F	Input signal to instrument cluster is okay.

## INSTRUMENTATION/DRIVER INFO.

### WARNING AND INDICATOR LIGHT BULB REMOVAL/INSTALLATION

A3U092255431W01

1. Disconnect the negative battery cable.
2. Remove the instrument cluster. (See 09–22–3 INSTRUMENT CLUSTER REMOVAL/INSTALLATION.)
3. Turn the socket counterclockwise to remove the bulb as shown in the figure.
4. Install in the reverse order of removal.

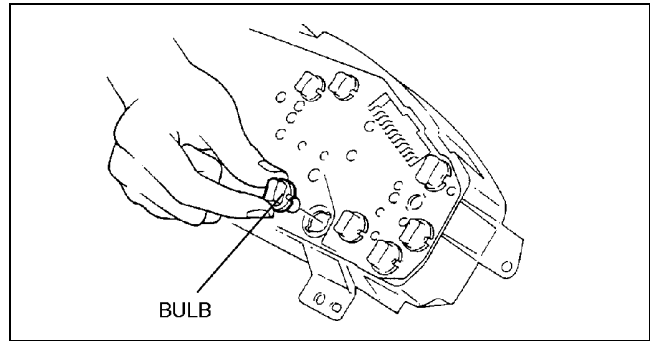

X3U922WBK

### FUEL GAUGE SENDER UNIT INSPECTION

A3U092260960W01

1. Remove the fuel gauge sender unit. (See 01–14–15 FUEL PUMP UNIT DISASSEMBLY/ASSEMBLY.)
2. Move the float to the topmost and bottommost positions, and verify that the resistance between terminals A and B of the unit and the position of the float are as indicated in the figure.
  - If they are not as indicated, replace the fuel gauge sender unit.

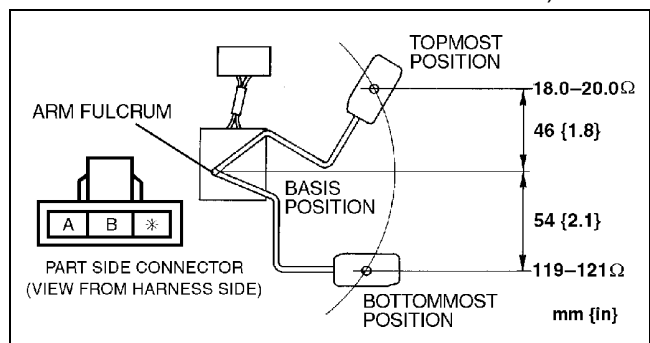

Y3U922WA0

09–22

### OIL PRESSURE SWITCH INSPECTION

A3U092218500W01

1. Verify that the oil pressure warning light illuminates when the ignition switch is turned to ON position.
2. Verify that the oil pressure warning light goes off when the engine is started.
  - If the oil pressure warning light does not illuminate or remains illuminated, inspect the oil pressure warning light bulb and related wiring harness.
  - If the oil pressure warning light bulb and related wiring harness are normal, inspect the oil pressure. (See 01–11–2 OIL PRESSURE INSPECTION.)
  - If the oil pressure is normal, replace the oil pressure switch.

### HORN REMOVAL/INSTALLATION

A3U092266790W01

1. Disconnect the negative battery cable.
2. Remove the front bumper. (See 09–10–5 FRONT BUMPER REMOVAL/INSTALLATION.)
3. Disconnect the horn connector.
4. Remove the bolt.
5. Remove the horn.
6. Install in the reverse order of removal.

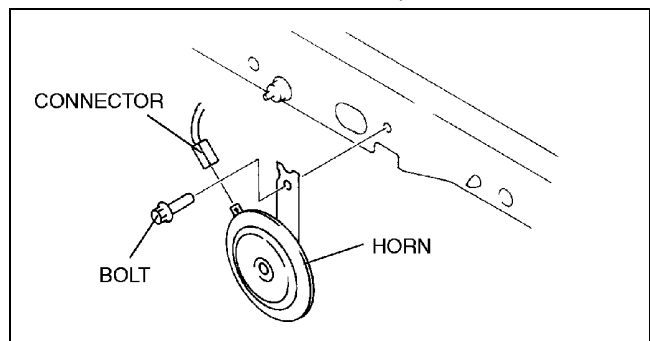

X3U922WBM

**09-50 TECHNICAL DATA**

**BODY & ACCESSORIES**

TECHNICAL DATA ..... 09-50-1

**BODY & ACCESSORIES TECHNICAL DATA**

A3U095001047W01

Item		Specifications (W) x number		
<b>LIGHTING SYSTEMS</b>				
Exterior lights	Headlight	4SD	60/55 x 2	
		5HB	High-beam	60 x 2
			Low-beam	55 x 2
	Front turn light/parking light		27/8 x 2	
	Front side marker light		5 x 2	
	Front fog light		55 x 2	
	Brake light/taillight		21/5 x 2	
	Rear turn light		21 x 2	
	Taillight (4SD)		3.8 x 2	
	Back-up light		21 x 2	
	Rear side marker light (4SD)		3.8 x 2	
	License plate light		5 x 2	
	High-mount brake light	In-vehicle type	21 x 1	
		Rear spoiler type	5.8 x 1	
Interior lights	Interior light	Front	8 x 1	
		Rear	10 x 1	
	Map light		5 x 2	
	Interior and map light		Interior 8 x 1, Map 5 x 2	
	Trunk compartment light (4SD)		5 x 1	
	Cargo compartment light (5HB)		5 x 1	
Instrument cluster illumination		3.4 x 2, 1.4 x 2		
<b>INSTRUMENTATION/DRIVER INFO.</b>				
Warning and indicator lights	MIL		1.4 x 1	
	Air bag system warning light		1.4 x 1	
	Seat belt warning light		1.4 x 1	
	Oil pressure warning light		1.4 x 1	
	Brake system warning light		1.4 x 1	
	ABS warning light		1.4 x 1	
	High beam indicator light		1.4 x 1	
	Turn indicator light		1.4 x 2	
	O/D OFF indicator light		1.4 x 1	
	Cruise set indicator light		1.4 x 1	
Washer fluid-level warning light		1.4 x 1		

09-50





# SERVICE TOOLS

## 09-60 SERVICE TOOLS

BODY & ACCESSORIES SST ..... 09-60-1

### BODY & ACCESSORIES SST

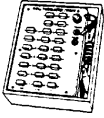
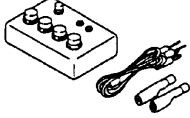
A3U096001047W01

<p>49 0305 870A Window tool set</p> 	<p>49 0839 285 Fuel and thermometer checker (OLD)</p> 	<p>49 N088 0A0 Fuel and thermometer checker (NEW)</p> 
<p>49 UN01 050 Removing tool</p> 	<p>—</p>	<p>—</p>

# ALPHABETICAL INDEX

**AI**  
SECTION

## A

A/C AMPLIFIER INSPECTION	07-40-13
A/C COMPRESSOR	
REMOVAL/INSTALLATION	07-11-11
ABBREVIATIONS	00-00-26
ABS HYDRAULIC UNIT (HU)/CONTROL MODULE (CM)	
INSPECTION	04-13-6
ABS HYDRAULIC UNIT (HU)/CONTROL MODULE (CM)	
REMOVAL/INSTALLATION	04-13-5
ABS HYDRAULIC UNIT (HU)/CONTROL MODULE (CM)	
SYSTEM INSPECTION	04-13-3
ABS LOCATION INDEX	04-13-1
ABS ON-BOARD DIAGNOSTIC	04-02-3
ABS SYSTEM DIAGRAM	04-02-2, 04-03-2, 04-13-2
ABS WHEEL-SPEED SENSOR (FRONT)	
REMOVAL/INSTALLATION	04-13-9
ABS WHEEL-SPEED SENSOR (FRONT/REAR)	
INSPECTION	04-13-9
ABS WHEEL-SPEED SENSOR (REAR)	
REMOVAL/INSTALLATION	04-13-10
ACCELERATOR CABLE ADJUSTMENT [FS]	01-13B-17
ACCELERATOR CABLE INSPECTION [FS]	01-13B-17
ACCELERATOR CABLE INSPECTION/ADJUSTMENT	
[ZM]	01-13A-13
ACCELERATOR CABLE REMOVAL/INSTALLATION	
[FS]	01-13B-16
ACCELERATOR CABLE REMOVAL/INSTALLATION	
[ZM]	01-13A-12
ACTUATOR CABLE INSTALLATION	01-20-5
ACTUATOR CABLE REMOVAL	01-20-5
AFTER REPAIR PROCEDURE	
[AUTOMATIC TRANSAXLE]	05-02-6
AFTER REPAIR PROCEDURE [FS]	01-02B-9
AFTER REPAIR PROCEDURE [FUEL SYSTEM]	01-14-5
AFTER REPAIR PROCEDURE [ZM]	01-02A-10
AIR BAG MODULE AND PRE-TENSIONER	
SEAT BELT DEPLOYMENT AUTHORIZATION	
PROCEDURES	08-10-13
AIR BAG MODULE AND PRE-TENSIONER SEAT BELT	
DEPLOYMENT PROCEDURES	08-10-13
AIR BAG MODULE AND PRE-TENSIONER SEAT BELT	
DISPOSAL PROCEDURES	08-10-23
AIR BAG SYSTEM LOCATION INDEX	08-10-2
AIR BAG SYSTEM SERVICE WARNINGS	08-10-3
AIR BAG SYSTEM TROUBLESHOOTING	
INDEX	08-03-4
AIR BAG SYSTEM WIRING DIAGRAM	08-02-2
AIR BAG SYSTEM WIRING DIAGRAM	08-03-1
AIR BLEEDING [BRAKES]	04-11-3
AIR BLEEDING [STEERING]	06-12-3
AIR FILTER INSPECTION	01-16-9
AIR INTAKE ACTUATOR INSPECTION	07-40-4
AIR INTAKE ACTUATOR	
REMOVAL/INSTALLATION	07-40-3

AIRFLOW MODE MAIN LINK	
REMOVAL/INSTALLATION	07-11-10
ANTENNA FEEDER (FRONT) INSPECTION	09-20-5
ANTENNA FEEDER (FRONT)	
REMOVAL/INSTALLATION	09-20-5
ANTENNA FEEDER (REAR) INSPECTION	09-20-6
ANTENNA FEEDER (REAR)	
REMOVAL/INSTALLATION	09-20-5
A-PILLAR TRIM REMOVAL/INSTALLATION	09-17-10
AUDIO UNIT INSTALLATION	09-20-6
AUDIO UNIT REMOVAL	09-20-6
AUTOMATIC TRANSAXLE (ATX) CROSS-SECTIONAL	
VIEW	05-17-4
AUTOMATIC TRANSAXLE (ATX) POWERTRAIN	
STRUCTURAL VIEW	05-17-10
AUTOMATIC TRANSAXLE (ATX)	
REMOVAL/INSTALLATION	05-17-31
AUTOMATIC TRANSAXLE BASIC INSPECTION	05-03-6
AUTOMATIC TRANSAXLE CONTROL SYSTEM WIRING	
DIAGRAM	05-02-2
AUTOMATIC TRANSAXLE FLUID (ATF)	
INSPECTION	05-17-17
AUTOMATIC TRANSAXLE FLUID (ATF)	
REPLACEMENT	05-17-18
AUTOMATIC TRANSAXLE LOCATION INDEX	05-17-2
AUTOMATIC TRANSAXLE ON-BOARD DIAGNOSTIC	
FUNCTION	05-02-6
AUTOMATIC TRANSAXLE SOLENOID VALVES	
INSPECTION	05-17-28
AUTOMATIC TRANSAXLE SOLENOID VALVES	
REMOVAL/INSTALLATION	05-17-30
AUTOMATIC TRANSAXLE SYMPTOM	
TROUBLESHOOTING ITEM TABLE	05-03-7
AUTOMATIC TRANSAXLE SYSTEM WIRING	
DIAGRAM	05-03-2
AUTOMATIC TRANSMISSION SHIFT MECHANISM	
LOCATION INDEX	05-18-1
AXLE (FRONT) LOCATION INDEX	03-11-1
AXLE (REAR) LOCATION INDEX	03-12-1

## B

BACK-UP LIGHT SWITCH INSPECTION	09-18-15
BACK-UP LIGHT SWITCH	
REMOVAL/INSTALLATION	09-18-15
BASE INSTALLATION	09-12-31
BASE REMOVAL	09-12-31
BASIC SYSTEM LOCATION INDEX	07-11-2
BATTERY INSPECTION	01-17-1
BATTERY RECHARGING	01-17-2
BATTERY REMOVAL/INSTALLATION	01-17-1
BEFORE REPAIR PROCEDURE	01-14-4
BELTLINE MOLDING (FRONT)	
REMOVAL/INSTALLATION	09-16-7
BELTLINE MOLDING (REAR)	
REMOVAL/INSTALLATION	09-16-7

AI

# ALPHABETICAL INDEX

BLOWER MOTOR INSPECTION	07-40-5
BLOWER MOTOR REMOVAL/INSTALLATION	07-40-4
BLOWER UNIT DISASSEMBLY/ASSEMBLY	07-11-3
BLOWER UNIT REMOVAL/INSTALLATION	07-11-3
BODY & ACCESSORIES SST	09-60-1
BODY & ACCESSORIES TECHNICAL DATA	09-50-1
B-PILLAR LOWER TRIM INSTALLATION	09-17-11
B-PILLAR LOWER TRIM REMOVAL	09-17-10
B-PILLAR UPPER TRIM REMOVAL/INSTALLATION	09-17-11
BRAKE (DISC, FRONT) INSPECTION	04-11-14
BRAKE (DISC, FRONT) REMOVAL/INSTALLATION	04-11-17
BRAKE (DISC, REAR) INSPECTION	04-11-21
BRAKE (DISC, REAR) REMOVAL/INSTALLATION	04-11-22
BRAKE (DRUM, REAR) INSPECTION	04-11-25
BRAKE (DRUM, REAR) REMOVAL/INSTALLATION	04-11-26
BRAKE PEDAL INSPECTION	04-11-3
BRAKE PEDAL REMOVAL/INSTALLATION	04-11-5
BRAKE SWITCH INSPECTION	04-11-5
BRAKES SST	04-60-1
BRAKES TECHNICAL DATA	04-50-1
BUCKLE (FRONT) REMOVAL/INSTALLATION	08-11-3
BUCKLE (REAR) REMOVAL/INSTALLATION	08-11-4
BUCKLE SWITCH INSPECTION	08-11-5
BUMPER (FRONT) DISASSEMBLY/ASSEMBLY	09-10-6
BUMPER (FRONT) REMOVAL/INSTALLATION	09-10-5
BUMPER (REAR) REMOVAL/INSTALLATION	09-10-7

## C

CALIPER (FRONT) DISASSEMBLY/ASSEMBLY	04-11-20
CALIPER (REAR) DISASSEMBLY/ASSEMBLY	04-11-24
CAMSHAFT POSITION (CMP) SENSOR INSPECTION [FS]	01-40B-35
CAMSHAFT POSITION (CMP) SENSOR INSPECTION [ZM]	01-40A-35
CAMSHAFT POSITION (CMP) SENSOR REMOVAL/INSTALLATION [FS]	01-40B-34
CAMSHAFT POSITION (CMP) SENSOR REMOVAL/INSTALLATION [ZM]	01-40A-35
CANISTER DRAIN CUT VALVE (CDCV) INSPECTION	01-16-10
CANISTER DRAIN CUT VALVE (CDCV) REMOVAL/INSTALLATION	01-16-9
CARGO COMPARTMENT LIGHT INSPECTION	09-18-24
CARGO COMPARTMENT LIGHT REMOVAL/INSTALLATION	09-18-23
CARGO COMPARTMENT LIGHT SWITCH INSPECTION	09-18-24
CATCH TANK INSPECTION	01-16-11
CENTER PANEL REMOVAL/INSTALLATION	09-17-4
CENTER ROOF ANTENNA (REAR) REMOVAL/INSTALLATION	09-20-3
CENTER ROOF ANTENNA (REAR) INSPECTION	09-20-3
CHARCOAL CANISTER INSPECTION	01-16-9
CHILD RESTRAINT SEAT ANCHOR REMOVAL/INSTALLATION	08-11-5
CIGARETTE LIGHTER INSPECTION	09-20-9

CIGARETTE LIGHTER REMOVAL/INSTALLATION	09-20-8
CLIMATE CONTROL UNIT DISASSEMBLY/ASSEMBLY	07-40-10
CLIMATE CONTROL UNIT INSPECTION	07-40-11
CLIMATE CONTROL UNIT INSTALLATION	07-40-10
CLIMATE CONTROL UNIT REMOVAL	07-40-9
CLIMATE CONTROL UNIT WIRE ADJUSTMENT	07-40-11
CLOCK SPRING ADJUSTMENT	08-10-8
CLOCK SPRING INSPECTION	08-10-10
CLOCK SPRING REMOVAL/INSTALLATION	08-10-9
CLUTCH COMPONENT LOCATION INDEX	05-10-2
CLUTCH COVER INSPECTION	05-10-13
CLUTCH DISC INSPECTION	05-10-14
CLUTCH FLUID INSPECTION	05-10-3
CLUTCH FLUID REPLACEMENT/AIR BLEEDING	05-10-3
CLUTCH MASTER CYLINDER DISASSEMBLY/ASSEMBLY	05-10-7
CLUTCH MASTER CYLINDER REMOVAL/INSTALLATION	05-10-6
CLUTCH PEDAL ADJUSTMENT	05-10-4
CLUTCH PEDAL INSPECTION	05-10-3
CLUTCH PEDAL REMOVAL/INSTALLATION	05-10-5
CLUTCH RELEASE COLLAR INSPECTION	05-10-15
CLUTCH RELEASE CYLINDER DISASSEMBLY/ASSEMBLY	05-10-10
CLUTCH RELEASE CYLINDER REMOVAL/INSTALLATION	05-10-8
CLUTCH SWITCH INSPECTION [FS]	01-40B-42
CLUTCH SWITCH INSPECTION [ZM]	01-40A-41
CLUTCH UNIT REMOVAL/INSTALLATION	05-10-11
COLUMN COVER REMOVAL/INSTALLATION	09-17-5
COMBINATION LIGHT (FRONT) REMOVAL/INSTALLATION	09-18-5
COMBINATION LIGHT (REAR) REMOVAL/INSTALLATION	09-18-10
COMBINATION SWITCH DISASSEMBLY/ASSEMBLY	09-18-13
COMBINATION SWITCH REMOVAL/INSTALLATION	09-18-12
COMPRESSION INSPECTION [FS]	01-10B-8
COMPRESSION INSPECTION [ZM]	01-10A-8
CONDENSER FAN INSPECTION	07-40-5
CONDENSER FAN REMOVAL/INSTALLATION	07-40-5
CONDENSER INSPECTION	07-11-13
CONDENSER REMOVAL/INSTALLATION	07-11-12
CONSOLE ADJUSTMENT	09-17-5
CONSOLE DISASSEMBLY/ASSEMBLY	09-17-6
CONSOLE REMOVAL/INSTALLATION	09-17-5
CONTROL SYSTEM COMPONENT LOCATION INDEX [FS]	01-40B-2
CONTROL SYSTEM COMPONENT LOCATION INDEX [ZM]	01-40A-2
CONTROL SYSTEM DEVICE AND CONTROL RELATIONSHIP CHART [FS]	01-02B-4
CONTROL SYSTEM DEVICE AND CONTROL RELATIONSHIP CHART [FS]	01-03B-2
CONTROL SYSTEM DEVICE AND CONTROL RELATIONSHIP CHART [ZM]	01-02A-5
CONTROL SYSTEM DEVICE AND RELATIONSHIP CHART [ZM]	01-03A-2
CONTROL SYSTEM DIAGRAM [FS]	01-40B-4
CONTROL SYSTEM DIAGRAM [ZM]	01-40A-4

# ALPHABETICAL INDEX

<p>CONTROL SYSTEM LOCATION INDEX . . . . .07-40-2</p> <p>CONTROL SYSTEM WIRING DIAGRAM [FS] . . . 01-02B-2</p> <p>CONTROL SYSTEM WIRING DIAGRAM [FS] . . . 01-40B-5</p> <p>CONTROL SYSTEM WIRING DIAGRAM [ZM] . . . 01-02A-3</p> <p>CONTROL SYSTEM WIRING DIAGRAM [ZM] . . . 01-40A-5</p> <p>CONTROL VALVE BODY REMOVAL/INSTALLATION . . . . .05-17-36</p> <p>CONVENTIONAL BRAKE SYSTEM LOCATION INDEX . . . . .04-11-2</p> <p>COOLING FAN MOTOR INSPECTION. . . . .01-12-9</p> <p>COOLING FAN MOTOR REMOVAL/INSTALLATION . . . . .01-12-9</p> <p>COOLING SYSTEM LOCATION INDEX . . . . .01-12-1</p> <p>COOLING SYSTEM SERVICE WARNINGS. . . . .01-12-2</p> <p>COOLING UNIT DISASSEMBLY/ASSEMBLY . . . .07-11-4</p> <p>COOLING UNIT REMOVAL/INSTALLATION . . . .07-11-3</p> <p>COWL GRILLE REMOVAL/INSTALLATION . . . .09-16-1</p> <p>C-PILLAR TRIM REMOVAL/INSTALLATION . . . .09-17-11</p> <p>CRANKSHAFT POSITION (CKP) SENSOR ADJUSTMENT [ZM] . . . . .01-40A-34</p> <p>CRANKSHAFT POSITION (CKP) SENSOR INSPECTION [FS] . . . . .01-40B-32</p> <p>CRANKSHAFT POSITION (CKP) SENSOR INSPECTION [ZM] . . . . .01-40A-32</p> <p>CRANKSHAFT POSITION (CKP) SENSOR REMOVAL/INSTALLATION [FS] . . . . .01-40B-34</p> <p>CRANKSHAFT POSITION (CKP) SENSOR REMOVAL/INSTALLATION [ZM] . . . . .01-40A-34</p> <p>CROSSMEMBER (FRONT) REMOVAL/INSTALLATION . . . . .02-13-8</p> <p>CROSSMEMBER (REAR) REMOVAL/INSTALLATION . . . . .02-14-6</p> <p>CRUISE ACTUATOR INSPECTION . . . . .01-20-4</p> <p>CRUISE ACTUATOR REMOVAL/INSTALLATION . .01-20-4</p> <p>CRUISE CONTROL MODULE INSPECTION . . . .01-20-2</p> <p>CRUISE CONTROL MODULE REMOVAL/INSTALLATION . . . . .01-20-2</p> <p>CRUISE CONTROL SWITCH INSPECTION. . . . .01-20-8</p> <p>CRUISE CONTROL SWITCH REMOVAL/INSTALLATION . . . . .01-20-7</p> <p>CRUISE CONTROL SYSTEM WIRING DIAGRAM . . . . .01-02C-1</p> <p>CRUISE CONTROL SYSTEM LOCATION INDEX . . . . .01-20-1</p> <p>CYLINDER HEAD GASKET REPLACEMENT [FS] . . . . .01-10B-14</p> <p>CYLINDER HEAD GASKET REPLACEMENT [ZM] . . . . .01-10A-13</p>	<p>DOOR (FRONT) DISASSEMBLY/ASSEMBLY . . . .09-11-2</p> <p>DOOR (FRONT) GLASS AND GUIDE REMOVAL/INSTALLATION . . . . .09-12-3</p> <p>DOOR (FRONT) REMOVAL/INSTALLATION . . . .09-11-1</p> <p>DOOR (REAR) ADJUSTMENT . . . . .09-11-4</p> <p>DOOR (REAR) DISASSEMBLY/ASSEMBLY. . . .09-11-5</p> <p>DOOR (REAR) REMOVAL/INSTALLATION . . . .09-11-4</p> <p>DOOR GLASS AND GUIDE (REAR) REMOVAL/INSTALLATION . . . . .09-12-4</p> <p>DOOR KEY CYLINDER SWITCH INSPECTION. . .09-14-6</p> <p>DOOR KEY CYLINDER SWITCH REMOVAL/INSTALLATION . . . . .09-14-6</p> <p>DOOR LOCK ACTUATOR (FRONT) INSPECTION . . . . .09-14-3</p> <p>DOOR LOCK ACTUATOR (FRONT) REMOVAL/INSTALLATION . . . . .09-14-3</p> <p>DOOR LOCK ACTUATOR (REAR) INSPECTION. .09-14-5</p> <p>DOOR LOCK ACTUATOR (REAR) REMOVAL/INSTALLATION . . . . .09-14-5</p> <p>DOOR LOCK AND OPENER (FRONT) REMOVAL/INSTALLATION . . . . .09-14-3</p> <p>DOOR LOCK AND OPENER (REAR) REMOVAL/INSTALLATION . . . . .09-14-4</p> <p>DOOR LOCK CONTROL MODULE INSPECTION . . . . .09-14-8</p> <p>DOOR LOCK CONTROL MODULE REMOVAL/INSTALLATION . . . . .09-14-10</p> <p>DOOR LOCK STRIKER REMOVAL/INSTALLATION . . . . .09-14-7</p> <p>DOOR LOCK SWITCH INSPECTION . . . . .09-14-6</p> <p>DOOR LOCK SWITCH REMOVAL/INSTALLATION . . . . .09-14-7</p> <p>DOOR LOCK-LINK SWITCH INSPECTION. . . . .09-14-4</p> <p>DOOR LOCK-LINK SWITCH REMOVAL/INSTALLATION . . . . .09-14-4</p> <p>DOOR SPEAKER (FRONT) REMOVAL/INSTALLATION . . . . .09-20-3</p> <p>DOOR SPEAKER (REAR) REMOVAL/INSTALLATION . . . . .09-20-3</p> <p>DOOR SPEAKER INSPECTION . . . . .09-20-4</p> <p>DOOR SWITCH INSPECTION. . . . .09-18-25</p> <p>DOOR SWITCH REMOVAL/INSTALLATION . . . .09-18-24</p> <p>DOOR TRIM (FRONT) REMOVAL/INSTALLATION . . . . .09-17-9</p> <p>DOOR TRIM (REAR) REMOVAL/INSTALLATION . . . . .09-17-9</p> <p>DRAIN HOSE (FRONT) INSTALLATION. . . . .09-15-4</p> <p>DRAIN HOSE (FRONT) REMOVAL . . . . .09-15-4</p> <p>DRAIN HOSE (REAR) INSTALLATION . . . . .09-15-5</p> <p>DRAIN HOSE (REAR) REMOVAL . . . . .09-15-4</p> <p>DRIVE BELT ADJUSTMENT [FS] . . . . .01-10B-4</p> <p>DRIVE BELT ADJUSTMENT [ZM] . . . . .01-10A-4</p> <p>DRIVE BELT INSPECTION [FS] . . . . .01-10B-3</p> <p>DRIVE BELT INSPECTION [ZM] . . . . .01-10A-3</p> <p>DRIVE PLATE REMOVAL/INSTALLATION . . . .05-17-46</p> <p>DRIVE SHAFT (FS MTX LEFT SIDE) DISASSEMBLY/ASSEMBLY . . . . .03-13-17</p> <p>DRIVE SHAFT (ZM, FS ATX, FS MTX RIGHT SIDE) DISASSEMBLY/ASSEMBLY . . . . .03-13-12</p> <p>DRIVE SHAFT LOCATION INDEX . . . . .03-13-2</p> <p>DRIVE SHAFT PRE-INSPECTION . . . . .03-13-8</p> <p>DRIVE SHAFT REMOVAL/INSTALLATION. . . .03-13-9</p> <p>DRIVELINE/AXLE SST . . . . .03-60-1</p> <p>DRIVELINE/AXLE TECHNICAL DATA . . . . .03-50-1</p>
--	--

## D

<p>DASHBOARD DISASSEMBLY/ASSEMBLY . . . .09-17-3</p> <p>DASHBOARD REMOVAL/INSTALLATION . . . .09-17-1</p> <p>DAYTIME RUNNING LIGHT (DRL) SYSTEM WIRING DIAGRAM . . . . .09-18-17</p> <p>DEFLECTOR REMOVAL/INSTALLATION . . . . .09-15-2</p> <p>DIAGNOSTIC ASSIST FUNCTION [AUDIO]. . . .09-02B-14</p> <p>DIAGNOSTIC MONITORING TEST RESULTS [FS] . . . . .01-02B-14</p> <p>DIAGNOSTIC MONITORING TEST RESULTS [ZM] . . . . .01-02A-14</p> <p>DISC PAD (FRONT) REPLACEMENT . . . . .04-11-19</p> <p>DISC PAD (REAR) REPLACEMENT. . . . .04-11-23</p> <p>DOOR (FRONT) ADJUSTMENT . . . . .09-11-1</p>
---

AI

# ALPHABETICAL INDEX

DRIVER-SIDE AIR BAG MODULE REMOVAL/INSTALLATION	08-10-5
DRL CONTROL MODULE INSPECTION (CANADA)	09-18-18
DRL CONTROL MODULE REMOVAL/INSTALLATION (CANADA)	09-18-18
DTC TABLE [FS]	01-02B-15
DTC TABLE [ZM]	01-02A-15
DUAL PROPORTIONING VALVE (WITHOUT ABS) AND BRAKE PIPE JOINT (WITH ABS) REPLACEMENT	04-11-14
DUAL PROPORTIONING VALVE (WITHOUT ABS) INSPECTION	04-11-13
DUCT (REAR) REMOVAL/INSTALLATION	07-11-11

## E

EGR BOOST SENSOR INSPECTION [FS]	01-40B-39
EGR BOOST SENSOR INSPECTION [ZM]	01-40A-38
EGR BOOST SENSOR SOLENOID VALVE INSPECTION	01-16-17
EGR SYSTEM DIAGRAM	01-16-14
EGR VALVE INSPECTION	01-16-15
EGR VALVE REMOVAL/INSTALLATION	01-16-15
ELECTRICAL SYSTEM	00-00-16
EMISSION SYSTEM LOCATION INDEX	01-16-2
ENGINE CONTROL SYSTEM OPERATION INSPECTION [FS]	01-03B-54
ENGINE CONTROL SYSTEM OPERATION INSPECTION [ZM]	01-03A-55
ENGINE COOLANT LEAKAGE INSPECTION	01-12-4
ENGINE COOLANT LEVEL INSPECTION	01-12-2
ENGINE COOLANT PROTECTION INSPECTION	01-12-2
ENGINE COOLANT REPLACEMENT	01-12-3
ENGINE COOLANT TEMPERATURE (ECT) SENSOR INSPECTION [FS]	01-40B-31
ENGINE COOLANT TEMPERATURE (ECT) SENSOR INSPECTION [ZM]	01-40A-31
ENGINE COOLANT TEMPERATURE (ECT) SENSOR REMOVAL/INSTALLATION [FS]	01-40B-30
ENGINE COOLANT TEMPERATURE (ECT) SENSOR REMOVAL/INSTALLATION [ZM]	01-40A-30
ENGINE DISASSEMBLY/ASSEMBLY [FS]	01-10B-24
ENGINE DISASSEMBLY/ASSEMBLY [ZM]	01-10A-24
ENGINE OIL INSPECTION	01-11-2
ENGINE OIL REPLACEMENT	01-11-3
ENGINE REMOVAL/INSTALLATION [FS]	01-10B-21
ENGINE REMOVAL/INSTALLATION [ZM]	01-10A-20
ENGINE SPEED SENSING POWER STEERING LOCATION INDEX	06-12-2
ENGINE SST	01-60-1
ENGINE TECHNICAL DATA	01-50-1
ENGINE TUNE-UP [FS]	01-10B-25
ENGINE TUNE-UP [ZM]	01-10A-25
ENTERTAINMENT LOCATION INDEX	09-20-1
EVAPORATIVE EMISSION (EVAP) CONTROL SYSTEM (FUEL TANK SIDE) COMPONENT REMOVAL/INSTALLATION	01-16-7
EVAPORATIVE EMISSION (EVAP) CONTROL SYSTEM DIAGRAM	01-16-6
EVAPORATIVE GAS CHECK VALVE (TWO-WAY) INSPECTION	01-16-8
EVAPORATOR INSPECTION	07-11-7

EXHAUST SYSTEM INSPECTION	01-15-1
EXHAUST SYSTEM REMOVAL/INSTALLATION	01-15-1
EXTRACTOR CHAMBER REMOVAL/INSTALLATION	09-16-1

## F

FENDER PANEL (FRONT) REMOVAL/INSTALLATION	09-10-8
FILAMENT INSPECTION	09-12-27
FILAMENT REPAIR	09-12-28
FLAP (FRONT) REMOVAL/INSTALLATION	09-16-2
FLAP (REAR) REMOVAL/INSTALLATION	09-16-2
FLASHER CONTROL MODULE INSPECTION	09-18-16
FLASHER CONTROL MODULE REMOVAL/INSTALLATION	09-18-16
FLOOR COVERING REMOVAL/INSTALLATION	09-17-17
FLUID LEVEL SENSOR INSPECTION	04-11-9
FLYWHEEL INSPECTION	05-10-15
FOG LIGHT (FRONT) ADJUSTMENT	09-18-9
FOG LIGHT (FRONT) REMOVAL/INSTALLATION	09-18-8
FOG LIGHT SWITCH (FRONT) INSPECTION	09-18-14
FOG LIGHT SWITCH (FRONT) REMOVAL/INSTALLATION	09-18-14
FUEL FILTER (HIGH-PRESSURE) REMOVAL/INSTALLATION	01-14-21
FUEL GAUGE SENDER UNIT INSPECTION	09-22-13
FUEL INJECTOR INSPECTION	01-14-24
FUEL INJECTOR REMOVAL/INSTALLATION	01-14-21
FUEL PRESSURE INSPECTION	01-14-6
FUEL PUMP UNIT DISASSEMBLY/ASSEMBLY	01-14-15
FUEL PUMP UNIT INSPECTION	01-14-15
FUEL PUMP UNIT REMOVAL/INSTALLATION	01-14-14
FUEL SHUT-OFF VALVE INSPECTION	01-14-14
FUEL SYSTEM DIAGRAM	01-14-4
FUEL SYSTEM LOCATION INDEX	01-14-2
FUEL TANK INSPECTION	01-14-13
FUEL TANK PRESSURE SENSOR INSPECTION [FS]	01-40B-40
FUEL TANK PRESSURE SENSOR INSPECTION [ZM]	01-40A-40
FUEL TANK REMOVAL/INSTALLATION	01-14-9
FUEL-FILLER CAP INSPECTION	01-16-13
FUEL-FILLER LID ADJUSTMENT	09-10-1
FUEL-FILLER LID AND OPENER REMOVAL/INSTALLATION	09-14-16
FUEL-FILLER LID REMOVAL/INSTALLATION	09-10-1
FUNDAMENTAL PROCEDURES	00-00-11
FUSE BLOCK REMOVAL/INSTALLATION	09-21-3
FUSE SERVICE CAUTION	09-21-2

## G

GENERAL PROCEDURES	05-10-3
GENERATOR INSPECTION	01-17-3
GENERATOR REMOVAL/INSTALLATION	01-17-3
GLASS PANEL ADJUSTMENT	09-15-3
GLASS PANEL REMOVAL/INSTALLATION	09-15-3
GLASS/WINDOWS/MIRRORS LOCATION INDEX	09-12-2
GLOVE COMPARTMENT REMOVAL/INSTALLATION	09-17-7

# ALPHABETICAL INDEX

## H

HAZARD WARNING SWITCH INSPECTION . . . . .	09-18-15
HAZARD WARNING SWITCH REMOVAL/INSTALLATION . . . . .	09-18-14
HEADLIGHT ADJUSTMENT . . . . .	09-18-5
HEADLIGHT BULB REMOVAL/INSTALLATION . . . . .	09-18-6
HEADLINER REMOVAL/INSTALLATION . . . . .	09-17-16
HEAT DUCT (REAR) REMOVAL/INSTALLATION . . . . .	07-11-11
HEATED OXYGEN SENSOR (HO2S) INSPECTION [FS] . . . . .	01-40B-37
HEATED OXYGEN SENSOR (HO2S) INSPECTION [ZM] . . . . .	01-40A-36
HEATER CORE INSPECTION . . . . .	07-11-10
HEATER UNIT DISASSEMBLY/ASSEMBLY . . . . .	07-11-9
HEATER UNIT REMOVAL/INSTALLATION . . . . .	07-11-7
HIGH-MOUNT BRAKE LIGHT REMOVAL/INSTALLATION . . . . .	09-18-11
HIGH-TENSION LEAD INSPECTION . . . . .	01-18-3
HIGH-TENSION LEAD REMOVAL/INSTALLATION . . . . .	01-18-3
HOOD ADJUSTMENT . . . . .	09-10-2
HOOD LOCK AND OPENER REMOVAL/INSTALLATION . . . . .	09-14-17
HOOD REMOVAL/INSTALLATION . . . . .	09-10-3
HORN REMOVAL/INSTALLATION . . . . .	09-22-13
HOW TO USE THIS MANUAL . . . . .	00-00-1
HVAC SST . . . . .	07-60-1
HVAC TECHNICAL DATA . . . . .	07-50-1
HVAC TROUBLESHOOTING INDEX . . . . .	07-03-1

## I

IDENTIFICATION NUMBER LOCATIONS . . . . .	00-00-24
IDLE AIR CONTROL (IAC) VALVE INSPECTION [FS] . . . . .	01-13B-8
IDLE AIR CONTROL (IAC) VALVE INSPECTION [ZM] . . . . .	01-13A-7
IDLE AIR CONTROL (IAC) VALVE REMOVAL/INSTALLATION [FS] . . . . .	01-13B-8
IDLE AIR CONTROL (IAC) VALVE REMOVAL/INSTALLATION [ZM] . . . . .	01-13A-6
IGNITION COIL INSPECTION . . . . .	01-18-2
IGNITION COIL REMOVAL/INSTALLATION . . . . .	01-18-1
IGNITION KEY ILLUMINATION BULB REMOVAL/INSTALLATION . . . . .	09-18-24
IGNITION SWITCH INSPECTION . . . . .	09-21-4
IGNITION SWITCH REMOVAL/INSTALLATION . . . . .	09-21-3
INPUT/TURBINE SPEED SENSOR INSPECTION . . . . .	05-17-26
INPUT/TURBINE SPEED SENSOR REMOVAL/INSTALLATION . . . . .	05-17-26
INSPECTION OF DTCS FOR CONDITION DETECTION MODE . . . . .	01-02C-8
INSPECTION OF DTCS FOR OPERATION MODE . . . . .	01-02C-2
INSPECTION OF SST (DEPLOYMENT TOOL) . . . . .	08-10-24
INSPECTION USING AN OSCILLOSCOPE (REFERENCE) [FS] . . . . .	01-40B-26
INSPECTION USING AN OSCILLOSCOPE (REFERENCE) [ZM] . . . . .	01-40A-25
INSTALLATION OF RADIO SYSTEM . . . . .	00-00-16

INSTRUMENT CLUSTER DISASSEMBLY/ASSEMBLY . . . . .	09-22-3
INSTRUMENT CLUSTER INPUT/OUTPUT CHECK MODE . . . . .	09-22-5
INSTRUMENT CLUSTER INSPECTION . . . . .	09-22-4
INSTRUMENT CLUSTER REMOVAL/INSTALLATION . . . . .	09-22-3
INSTRUMENT CLUSTER REPAIR . . . . .	09-22-4
INSTRUMENT CLUSTER SYSTEM WIRING DIAGRAM . . . . .	09-22-2
INSTRUMENTATION/DRIVER INFO. LOCATION INDEX . . . . .	09-22-1
INTAKE AIR TEMPERATURE (IAT) SENSOR INSPECTION [FS] . . . . .	01-40B-27
INTAKE-AIR SYSTEM FLOW DIAGRAM [FS] . . . . .	01-13B-4
INTAKE-AIR SYSTEM FLOW DIAGRAM [ZM] . . . . .	01-13A-3
INTAKE-AIR SYSTEM LOCATION INDEX [FS] . . . . .	01-13B-2
INTAKE-AIR SYSTEM LOCATION INDEX [ZM] . . . . .	01-13A-2
INTAKE-AIR SYSTEM REMOVAL/INSTALLATION [FS] . . . . .	01-13B-6
INTAKE-AIR SYSTEM REMOVAL/INSTALLATION [ZM] . . . . .	01-13A-5
INTERIOR AND MAP LIGHT INSPECTION . . . . .	09-18-20
INTERIOR AND MAP LIGHT REMOVAL/INSTALLATION . . . . .	09-18-20
INTERIOR LIGHT INSPECTION . . . . .	09-18-22
INTERIOR LIGHT REMOVAL/INSTALLATION . . . . .	09-18-22
INTERLOCK CABLE INSPECTION . . . . .	05-18-1
INTERMITTENT CONCERN TROUBLESHOOTING [FS] . . . . .	01-03B-4
INTERMITTENT CONCERN TROUBLESHOOTING [ZM] . . . . .	01-03A-4
INTERMITTENT REAR WIPER RELAY INSPECTION . . . . .	09-19-16
INTERMITTENT REAR WIPER RELAY REMOVAL/INSTALLATION . . . . .	09-19-16

## J

JACKING POSITIONS . . . . .	00-00-21
JOINT SHAFT DISASSEMBLY/ASSEMBLY . . . . .	03-13-6
JOINT SHAFT PRE-INSPECTION . . . . .	03-13-2
JOINT SHAFT REMOVAL/INSTALLATION . . . . .	03-13-3

## K

KEY REMINDER SWITCH INSPECTION . . . . .	09-21-4
KEY REMINDER SWITCH REMOVAL/INSTALLATION . . . . .	09-21-4
KEYLESS CONTROL MODULE ID CODE CHANGE . . . . .	09-14-14
KEYLESS CONTROL MODULE INSPECTION . . . . .	09-14-11
KEYLESS CONTROL MODULE REMOVAL/INSTALLATION . . . . .	09-14-12
KEYLESS ENTRY SYSTEM CHECK SHEET . . . . .	09-03-2
KEYLESS ENTRY SYSTEM PREINSPECTION . . . . .	09-03-3
KEYLESS ENTRY SYSTEM TROUBLESHOOTING INDEX . . . . .	09-03-3
KEYLESS ENTRY SYSTEM WIRING DIAGRAM . . . . .	09-03-1
KEYLESS ENTRY SYSTEM WIRING DIAGRAM . . . . .	09-14-10
KNOCK SENSOR INSPECTION [FS] . . . . .	01-40B-36
KNOCK SENSOR REMOVAL/INSTALLATION [FS] . . . . .	01-40B-37

AI

# ALPHABETICAL INDEX

## L

LATERAL LINK AND TRAILING LINK REMOVAL/INSTALLATION	02-14-5
LICENSE PLATE LIGHT REMOVAL/INSTALLATION	09-18-12
LIFTGATE ADJUSTMENT	09-11-8
LIFTGATE DISASSEMBLY/ASSEMBLY	09-11-7
LIFTGATE GARNISH REMOVAL/INSTALLATION	09-16-3
LIFTGATE LOCK ACTUATOR INSPECTION	09-14-5
LIFTGATE LOCK ACTUATOR REMOVAL/INSTALLATION	09-14-5
LIFTGATE LOCK STRIKER REMOVAL/INSTALLATION	09-14-7
LIFTGATE REMOVAL/INSTALLATION	09-11-6
LIFTGATE TRIM REMOVAL/INSTALLATION	09-17-16
LIGHT SWITCH INSPECTION	09-18-13
LIGHT SWITCH REMOVAL/INSTALLATION	09-18-13
LIGHTING SYSTEMS LOCATION INDEX	09-18-2
LOWER ARM (FRONT) INSPECTION	02-13-7
LOWER ARM (FRONT) REMOVAL/INSTALLATION	02-13-5
LOWER MODULE REMOVAL/INSTALLATION	09-20-8
LOWER PANEL REMOVAL/INSTALLATION	09-17-7
LUBRICATION LOCATION INDEX	01-11-1

## M

MAGNETIC CLUTCH ADJUSTMENT	07-40-7
MAGNETIC CLUTCH DISASSEMBLY/ASSEMBLY	07-40-6
MAGNETIC CLUTCH INSPECTION	07-40-8
MAIN FUSE REMOVAL/INSTALLATION	09-21-2
MANUAL OUTSIDE MIRROR REMOVAL/INSTALLATION	09-12-29
MANUAL TRANSAXLE (MTX) REMOVAL/INSTALLATION [F25M-R]	05-15A-4
MANUAL TRANSAXLE (MTX) REMOVAL/INSTALLATION [G15M-R]	05-15B-4
MANUAL TRANSAXLE [F25M-R] LOCATION INDEX	05-15A-1
MANUAL TRANSAXLE [G15M-R] LOCATION INDEX	05-15B-1
MANUAL WINDOW REGULATOR (FRONT) REMOVAL/INSTALLATION	09-12-6
MANUAL WINDOW REGULATOR (REAR) REMOVAL/INSTALLATION	09-12-7
MAP LIGHT INSPECTION	09-18-21
MAP LIGHT REMOVAL/INSTALLATION	09-18-21
MASS AIR FLOW (MAF) SENSOR INSPECTION [FS]	01-40B-28
MASS AIR FLOW (MAF)/INTAKE AIR TEMPERATURE (IAT) SENSOR INSPECTION [ZM]	01-40A-26
MASTER CYLINDER DISASSEMBLY/ASSEMBLY	04-11-10
MASTER CYLINDER REMOVAL/INSTALLATION	04-11-6
MECHANICAL LOCATION INDEX [FS]	01-10B-2
MECHANICAL LOCATION INDEX [ZM]	01-10A-2
MECHANICAL SYSTEM TEST	05-17-11
METER HOOD REMOVAL/INSTALLATION	09-17-8

## N

NEUTRAL SWITCH INSPECTION [FS]	01-40B-43
NEUTRAL SWITCH INSPECTION [ZM]	01-40A-42
NONRETURN VALVE INSPECTION	01-14-14

## O

O/D OFF INDICATOR LIGHT INSPECTION	05-17-30
O/D OFF SWITCH INSPECTION	05-17-19
O/D OFF SWITCH REMOVAL/INSTALLATION	05-17-19
OBD-II DIAGNOSTIC MONITORING TEST RESULTS [FS]	01-02B-6
OBD-II DIAGNOSTIC MONITORING TEST RESULTS [ZM]	01-02A-7
OBD-II DRIVE MODE [FS]	01-02B-10
OBD-II DRIVE MODE [ZM]	01-02A-11
OBD-II FREEZE FRAME DATA [FS]	01-02B-6
OBD-II FREEZE FRAME DATA [ZM]	01-02A-7
OBD-II ON-BOARD SYSTEM READINESS TEST [FS]	01-02B-6
OBD-II ON-BOARD SYSTEM READINESS TEST [ZM]	01-02A-7
OBD-II PARAMETER IDENTIFICATION (PID) ACCESS [FS]	01-02B-7
OBD-II PARAMETER IDENTIFICATION (PID) ACCESS [ZM]	01-02A-8
OBD-II PENDING TROUBLE CODES [FS]	01-02B-6
OBD-II PENDING TROUBLE CODES [ZM]	01-02A-7
OBD-II READ/CLEAR DIAGNOSTIC TEST RESULTS [FS]	01-02B-7
OBD-II READ/CLEAR DIAGNOSTIC TEST RESULTS [ZM]	01-02A-8
OIL COOLER FLUSHING	05-17-40
OIL COOLER REMOVAL/INSTALLATION	05-17-41
OIL FILTER REPLACEMENT	01-11-3
OIL PAN REMOVAL/INSTALLATION	01-11-4
OIL PRESSURE INSPECTION	01-11-2
OIL PRESSURE SWITCH INSPECTION	09-22-13
OIL PUMP DISASSEMBLY/ASSEMBLY	01-11-14
OIL PUMP INSPECTION	01-11-15
OIL PUMP REMOVAL/INSTALLATION	01-11-10
OIL SEAL (DIFFERENTIAL) REPLACEMENT [F25M-R]	05-15A-2
OIL SEAL (DIFFERENTIAL) REPLACEMENT [G15M-R]	05-15B-2
OIL SEAL (FRONT) REPLACEMENT [FS]	01-10B-19
OIL SEAL (FRONT) REPLACEMENT [ZM]	01-10A-18
OIL SEAL (REAR) REPLACEMENT [FS]	01-10B-20
OIL SEAL (REAR) REPLACEMENT [ZM]	01-10A-19
OIL SEAL (TRANSAXLE) REPLACEMENT	05-17-36
ON-BOARD DIAGNOSTIC FUNCTION [KEYLESS ENTRY SYSTEM]	09-02A-2
ON-BOARD DIAGNOSTIC TEST [FS]	01-02B-7
ON-BOARD DIAGNOSTIC TEST [ZM]	01-02A-8
OUTSIDE MIRROR GLASS INSTALLATION	09-12-29
OUTSIDE MIRROR GLASS REMOVAL	09-12-29

## P

PANEL LIGHT CONTROL SWITCH INSPECTION	09-18-26
--	----------

# ALPHABETICAL INDEX

PANEL LIGHT CONTROL SWITCH REMOVAL/INSTALLATION . . . . .	09-18-25
PARKING BRAKE (LEVER TYPE) ADJUSTMENT . . . . .	04-12-1
PARKING BRAKE (LEVER TYPE) INSPECTION . . . . .	04-12-1
PARKING BRAKE (LEVER TYPE) REMOVAL/INSTALLATION . . . . .	04-12-2
PARKING BRAKE SYSTEM LOCATION INDEX . . . . .	04-12-1
PASSENGER-SIDE AIR BAG MODULE REMOVAL/INSTALLATION . . . . .	08-10-6
PCM INSPECTION (AUTOMATIC TRANSAXLE) . . . . .	05-17-30
PCM INSPECTION [FS] . . . . .	01-40B-7
PCM INSPECTION [ZM] . . . . .	01-40A-7
PCM REMOVAL/INSTALLATION (AUTOMATIC TRANSAXLE) . . . . .	05-17-30
PCM REMOVAL/INSTALLATION [FS] . . . . .	01-40B-7
PCM REMOVAL/INSTALLATION [ZM] . . . . .	01-40A-7
PID/DATA MONITOR INSPECTION . . . . .	05-02-68
PILLAR ANTENNA INSPECTION . . . . .	09-20-2
PILLAR ANTENNA INSTALLATION . . . . .	09-20-2
PILLAR ANTENNA REMOVAL . . . . .	09-20-2
PILOT BEARING INSPECTION . . . . .	05-10-15
PLATE REMOVAL/INSTALLATION [ZM] . . . . .	01-40A-34
POSITIVE CRANKCASE VENTILATION (PCV) SYSTEM FLOW DIAGRAM . . . . .	01-16-18
POSITIVE CRANKCASE VENTILATION (PCV) VALVE INSPECTION . . . . .	01-16-18
POWER BRAKE UNIT INSPECTION . . . . .	04-11-11
POWER BRAKE UNIT REMOVAL/INSTALLATION . . . . .	04-11-13
POWER DOOR LOCK SYSTEM WIRING DIAGRAM . . . . .	09-14-8
POWER OUTSIDE MIRROR INSPECTION . . . . .	09-12-28
POWER OUTSIDE MIRROR REMOVAL/INSTALLATION . . . . .	09-12-28
POWER OUTSIDE MIRROR SWITCH INSPECTION . . . . .	09-12-30
POWER OUTSIDE MIRROR SWITCH REMOVAL/INSTALLATION . . . . .	09-12-30
POWER STEERING FLUID INSPECTION . . . . .	06-12-3
POWER STEERING OIL PUMP (FS) DISASSEMBLY/ASSEMBLY . . . . .	06-12-27
POWER STEERING OIL PUMP (ZM) DISASSEMBLY/ASSEMBLY . . . . .	06-12-25
POWER STEERING OIL PUMP REMOVAL/INSTALLATION . . . . .	06-12-23
POWER STEERING PRESSURE (PSP) SWITCH INSPECTION [FS] . . . . .	01-40B-44
POWER STEERING PRESSURE (PSP) SWITCH INSPECTION [ZM] . . . . .	01-40A-43
POWER SYSTEMS LOCATION INDEX . . . . .	09-21-1
POWER WINDOW MAIN SWITCH INSPECTION . . . . .	09-12-8
POWER WINDOW MAIN SWITCH REMOVAL/INSTALLATION . . . . .	09-12-7
POWER WINDOW MOTOR INSPECTION . . . . .	09-12-5
POWER WINDOW REGULATOR (FRONT) DISASSEMBLY/ASSEMBLY . . . . .	09-12-5
POWER WINDOW REGULATOR (FRONT) REMOVAL/INSTALLATION . . . . .	09-12-5
POWER WINDOW REGULATOR (REAR) DISASSEMBLY/ASSEMBLY . . . . .	09-12-6
POWER WINDOW REGULATOR (REAR) REMOVAL/INSTALLATION . . . . .	09-12-6
POWER WINDOW SUBSWITCH INSPECTION . . . . .	09-12-10

POWER WINDOW SUBSWITCH REMOVAL/INSTALLATION . . . . .	09-12-9
PRC SOLENOID VALVE INSPECTION . . . . .	01-14-31
PRC SOLENOID VALVE REMOVAL/INSTALLATION . . . . .	01-14-31
PRECAUTION (BRAKES) . . . . .	04-10-1
PRECAUTION (DRIVELINE/AXLE) . . . . .	03-10-1
PRECAUTION (STEERING) . . . . .	06-10-1
PRECAUTION (SUSPENSION) . . . . .	02-10-1
PRE-DELIVERY INSPECTION . . . . .	00-00-27
PRESSURE REGULATOR INSPECTION . . . . .	01-14-28
PRESSURE REGULATOR REMOVAL/INSTALLATION . . . . .	01-14-27
PULSATION DAMPER INSPECTION . . . . .	01-14-31
PULSATION DAMPER REMOVAL/INSTALLATION . . . . .	01-14-30
PURGE SOLENOID VALVE INSPECTION . . . . .	01-16-12
PURGE SOLENOID VALVE REMOVAL/INSTALLATION . . . . .	01-16-11

## Q

QUARTER WINDOW GLASS INSTALLATION . . . . .	09-12-26
QUARTER WINDOW GLASS REMOVAL . . . . .	09-12-24

## R

RADIATOR CAP INSPECTION . . . . .	01-12-4
RADIATOR GRILLE REMOVAL/INSTALLATION . . . . .	09-16-2
RADIATOR REMOVAL/INSTALLATION . . . . .	01-12-4
REAR FINISHER REMOVAL/INSTALLATION . . . . .	09-16-3
REAR PACKAGE SPEAKER INSPECTION . . . . .	09-20-4
REAR PACKAGE SPEAKER REMOVAL/INSTALLATION . . . . .	09-20-4
REAR PACKAGE TRIM REMOVAL/INSTALLATION . . . . .	09-17-12
REAR WINDOW DEFROSTER SWITCH INSPECTION . . . . .	09-12-28
REARVIEW MIRROR INSTALLATION . . . . .	09-12-31
REARVIEW MIRROR REMOVAL . . . . .	09-12-30
RECEIVER/DRIER REMOVAL/INSTALLATION . . . . .	07-11-13
REFRIGERANT CHARGING . . . . .	07-10-3
REFRIGERANT LINES REMOVAL/INSTALLATION . . . . .	07-11-14
REFRIGERANT PRESSURE CHECK . . . . .	07-10-3
REFRIGERANT PRESSURE SWITCH INSPECTION . . . . .	07-40-9
REFRIGERANT PRESSURE SWITCH REMOVAL/INSTALLATION . . . . .	07-40-9
REFRIGERANT RECOVERY . . . . .	07-10-3
REFRIGERANT SYSTEM GENERAL PROCEDURES . . . . .	07-10-2
REFRIGERANT SYSTEM PERFORMANCE TEST . . . . .	07-10-2
REFRIGERANT SYSTEM SERVICE CAUTIONS . . . . .	07-10-1
REFRIGERANT SYSTEM SERVICE WARNINGS . . . . .	07-10-1
REGULATOR HANDLE INSTALLATION . . . . .	09-12-10
REGULATOR HANDLE REMOVAL . . . . .	09-12-10
RELAY INSPECTION . . . . .	09-21-5
RESISTOR INSPECTION . . . . .	07-40-6
RESISTOR REMOVAL/INSTALLATION . . . . .	07-40-6
RESTRAINTS SST . . . . .	08-60-1



## ALPHABETICAL INDEX

ROAD TEST .....	05-17-14
ROOF CARRIER REMOVAL/INSTALLATION .....	09-16-5
ROOF MOLDING REMOVAL/INSTALLATION .....	09-16-8
ROOF RACK DISASSEMBLY/ASSEMBLY .....	09-16-5
ROOF RACK REMOVAL/INSTALLATION .....	09-16-4
ROOM FUSE INSTALLATION .....	09-21-3

### S

SAE STANDARDS .....	00-00-25
SAS CONTROL MODULE BRACKET REMOVAL/INSTALLATION .....	08-10-12
SAS CONTROL MODULE REMOVAL/INSTALLATION .....	08-10-12
SCHEDULED MAINTENANCE .....	00-00-29
SCUFF PLATE (FRONT) REMOVAL/INSTALLATION .....	09-17-13
SCUFF PLATE (REAR) REMOVAL/INSTALLATION .....	09-17-13
SEAT (FRONT) DISASSEMBLY/ASSEMBLY .....	09-13-2
SEAT (FRONT) REMOVAL/INSTALLATION .....	09-13-1
SEAT (REAR) DISASSEMBLY/ASSEMBLY .....	09-13-7
SEAT (REAR) REMOVAL/INSTALLATION .....	09-13-5
SEAT BELT (FRONT) REMOVAL/INSTALLATION .....	08-11-1
SEAT BELT (REAR) REMOVAL/INSTALLATION ..	08-11-2
SEAT BELT (REAR, CENTER) REMOVAL/INSTALLATION .....	08-11-3
SEAT BELT INSPECTION .....	08-11-4
SECURITY AND LOCKS LOCATION INDEX .....	09-14-2
SELECTOR LEVER ADJUSTMENT .....	05-18-2
SELECTOR LEVER DISASSEMBLY/ASSEMBLY ..	05-18-8
SELECTOR LEVER INSPECTION .....	05-18-2
SELECTOR LEVER REMOVAL/INSTALLATION ..	05-18-3
SHIFT MECHANISM REMOVAL/INSTALLATION ..	05-16-2
SHOCK ABSORBER (FRONT) DISPOSAL .....	02-13-4
SHOCK ABSORBER (FRONT) INSPECTION .....	02-13-4
SHOCK ABSORBER (REAR) DISPOSAL .....	02-14-3
SHOCK ABSORBER (REAR) INSPECTION .....	02-14-3
SHOCK ABSORBER AND COIL SPRING (FRONT) REMOVAL/INSTALLATION .....	02-13-2
SHOCK ABSORBER AND SPRING (REAR) REMOVAL/INSTALLATION .....	02-14-2
SIDE AIR BAG MODULE REMOVAL/INSTALLATION .....	08-10-7
SIDE AIR BAG SENSOR REMOVAL/INSTALLATION .....	08-10-10
SIDE MARKER LIGHT (FRONT) REMOVAL/INSTALLATION .....	09-18-7
SIDE PANEL REMOVAL/INSTALLATION .....	09-17-8
SIDE PROTECTOR INSTALLATION .....	09-16-4
SIDE PROTECTOR REMOVAL .....	09-16-3
SIDE STEP MOLDING REMOVAL/INSTALLATION .....	09-16-4
SIDE TRIM (FRONT) REMOVAL/INSTALLATION .....	09-17-13
SIDE WALL REMOVAL/INSTALLATION .....	09-17-8
SLIDING SUNROOF SYSTEM WIRING DIAGRAM .....	09-15-14
SPOILER (REAR) REMOVAL/INSTALLATION .....	09-16-8
STABILIZER (FRONT) REMOVAL/INSTALLATION .....	02-13-7
STABILIZER (REAR) REMOVAL/INSTALLATION ..	02-14-4

STABILIZER CONTROL LINK (FRONT) INSPECTION .....	02-13-8
STABILIZER CONTROL LINK (REAR) INSPECTION .....	02-14-4
STARTER INSPECTION .....	01-19-2
STARTER INTERLOCK SWITCH INSPECTION (MTX) .....	01-19-2
STARTER REMOVAL/INSTALLATION .....	01-19-1
STARTING PROCEDURE FOR ON-BOARD DIAGNOSTIC TEST MODE .....	09-02B-1
STAY DAMPER DISPOSAL .....	09-11-8
STEERING GEAR AND LINKAGE ASSEMBLY ..	06-12-17
STEERING GEAR AND LINKAGE DISASSEMBLY .....	06-12-11
STEERING GEAR AND LINKAGE INSPECTION ..	06-12-15
STEERING GEAR AND LINKAGE REMOVAL/INSTALLATION .....	06-12-9
STEERING LOCK (ATX MODEL) INSPECTION ..	06-12-9
STEERING SHAFT INSPECTION .....	06-12-8
STEERING SST .....	06-60-1
STEERING TECHNICAL DATA .....	06-50-1
STEERING WHEEL AND COLUMN INSPECTION .....	06-12-5
STEERING WHEEL AND COLUMN REMOVAL/INSTALLATION .....	06-12-6
STRUT BAR (FRONT) REMOVAL/INSTALLATION .....	02-13-10
SUNROOF LOCATION INDEX .....	09-15-1
SUNROOF MOTOR INSPECTION .....	09-15-12
SUNROOF MOTOR INSTALLATION .....	09-15-11
SUNROOF MOTOR REMOVAL .....	09-15-11
SUNROOF RELAY INSPECTION .....	09-15-16
SUNROOF RELAY REMOVAL/INSTALLATION ..	09-15-14
SUNROOF SWITCH INSPECTION .....	09-15-18
SUNROOF SWITCH REMOVAL/INSTALLATION .....	09-15-18
SUNROOF UNIT ASSEMBLY .....	09-15-8
SUNROOF UNIT DISASSEMBLY .....	09-15-5
SUNROOF UNIT REMOVAL/INSTALLATION .....	09-15-5
SUPPLIER IDENTIFICATION PROCEDURE .....	09-02B-1
SUSPENSION (FRONT) LOCATION INDEX .....	02-13-1
SUSPENSION (REAR) LOCATION INDEX .....	02-14-1
SUSPENSION SST .....	02-60-1
SUSPENSION TECHNICAL DATA .....	02-50-1
SYMPTOM DIAGNOSTIC INDEX [FS] .....	01-03B-7
SYMPTOM DIAGNOSTIC INDEX [ZM] .....	01-03A-7
SYMPTOM QUICK DIAGNOSIS CHART [FS] ..	01-03B-9
SYMPTOM QUICK DIAGNOSIS CHART [ZM] ..	01-03A-9
SYMPTOM TROUBLESHOOTING [BRAKES] .....	04-03-4
SYSTEM WIRING DIAGRAM [POWERTRAIN] .....	05-17-6

### T

THERMOSTAT INSPECTION .....	01-12-7
THERMOSTAT REMOVAL/INSTALLATION .....	01-12-5
THROTTLE POSITION (TP) SENSOR INSPECTION [FS] .....	01-40B-29
THROTTLE POSITION (TP) SENSOR INSPECTION [ZM] .....	01-40A-28
THROTTLE POSITION (TP) SENSOR REMOVAL/INSTALLATION [ZM] .....	01-40A-30
TIMING BELT REMOVAL/INSTALLATION [FS] ..	01-10B-8
TIMING BELT REMOVAL/INSTALLATION [ZM] ..	01-10A-9
TIRE HOUSE TRIM REMOVAL/INSTALLATION ..	09-17-13

# ALPHABETICAL INDEX

TOWING .....	00-00-22
TRANSAXLE FLUID TEMPERATURE (TFT) SENSOR INSPECTION.....	05-17-25
TRANSAXLE FLUID TEMPERATURE (TFT) SENSOR REMOVAL/INSTALLATION .....	05-17-25
TRANSAXLE OIL INSPECTION [F25M-R] .....	05-15A-2
TRANSAXLE OIL INSPECTION [G15M-R].....	05-15B-2
TRANSAXLE OIL REPLACEMENT [F25M-R]....	05-15A-2
TRANSAXLE OIL REPLACEMENT [G15M-R] ...	05-15B-2
TRANSAXLE RANGE (TR) SWITCH ADJUSTMENT .....	05-17-23
TRANSAXLE RANGE (TR) SWITCH INSPECTION.....	05-17-20
TRANSAXLE RANGE (TR) SWITCH REMOVAL/INSTALLATION .....	05-17-20
TRANSMISSION/TRANSAXLE SST.....	05-60-1
TRANSMISSION/TRANSAXLE TECHNICAL DATA.....	05-50-1
TRANSMITTER BATTERY INSPECTION.....	09-14-15
TRANSMITTER BATTERY REPLACEMENT .....	09-14-15
TRANSVERSE MEMBER (ZM (ATX), FS) REMOVAL/INSTALLATION .....	02-13-9
TRUNK COMPARTMENT LIGHT BULB REMOVAL/INSTALLATION .....	09-18-23
TRUNK COMPARTMENT LIGHT SWITCH INSPECTION.....	09-18-23
TRUNK END TRIM REMOVAL/INSTALLATION ..	09-17-14
TRUNK LID ADJUSTMENT.....	09-10-3
TRUNK LID LOCK REMOVAL/INSTALLATION ..	09-14-17
TRUNK LID OPENER CABLE ADJUSTMENT ...	09-14-18
TRUNK LID OPENER REMOVAL/INSTALLATION .....	09-14-18
TRUNK LID REMOVAL/INSTALLATION.....	09-10-4
TRUNK LID STRIKER REMOVAL/INSTALLATION .....	09-14-18
TRUNK SIDE TRIM REMOVAL/INSTALLATION ..	09-17-15
TRUNK SIDE UPPER TRIM REMOVAL/INSTALLATION .....	09-17-15
TURN LIGHT (FRONT)/PARKING LIGHT BULB REMOVAL/INSTALLATION .....	09-18-7

## U

UNITS .....	00-00-10
UPPER MODULE REMOVAL/INSTALLATION.....	09-20-7

## V

VACUUM CHAMBER CHECK VALVE INSPECTION [FS] .....	01-13B-9
VACUUM CHAMBER CHECK VALVE REMOVAL/INSTALLATION [FS].....	01-13B-9
VACUUM HOSE CHECK VALVE INSPECTION (POWER BRAKE UNIT) .....	04-11-3
VACUUM HOSE ROUTING DIAGRAM [FS].....	01-13B-5
VACUUM HOSE ROUTING DIAGRAM [ZM].....	01-13A-3
VALVE CLEARANCE ADJUSTMENT [FS] .....	01-10B-6
VALVE CLEARANCE ADJUSTMENT [ZM].....	01-10A-6
VALVE CLEARANCE INSPECTION [FS] .....	01-10B-5
VALVE CLEARANCE INSPECTION [ZM] .....	01-10A-5
VARIABLE INERTIA CHARGING SYSTEM (VICS) CHECK VALVE (ONE-WAY) INSPECTION [FS] .....	01-13B-10

VARIABLE INERTIA CHARGING SYSTEM (VICS) CHECK VALVE (ONE-WAY) REMOVAL/INSTALLATION [FS] .....	01-13B-10
VARIABLE INERTIA CHARGING SYSTEM (VICS) DIAGRAM [FS].....	01-13B-10
VARIABLE INERTIA CHARGING SYSTEM (VICS) SHUTTER VALVE ACTUATOR INSPECTION [FS].....	01-13B-11
VARIABLE INERTIA CHARGING SYSTEM (VICS) SHUTTER VALVE ACTUATOR REMOVAL/INSTALLATION [FS] .....	01-13B-11
VARIABLE INERTIA CHARGING SYSTEM (VICS) SOLENOID VALVE INSPECTION [FS].....	01-13B-12
VARIABLE TUMBLE CONTROL SYSTEM (VTCS) CHECK VALVE (ONE-WAY) INSPECTION [ZM] .....	01-13A-9
VARIABLE TUMBLE CONTROL SYSTEM (VTCS) CHECK VALVE (ONE-WAY) REMOVAL/INSTALLATION [ZM].....	01-13A-8
VARIABLE TUMBLE CONTROL SYSTEM (VTCS) DELAY VALVE INSPECTION [FS] .....	01-13B-15
VARIABLE TUMBLE CONTROL SYSTEM (VTCS) DELAY VALVE INSPECTION [ZM] .....	01-13A-11
VARIABLE TUMBLE CONTROL SYSTEM (VTCS) DELAY VALVE REMOVAL/INSTALLATION [FS].....	01-13B-14
VARIABLE TUMBLE CONTROL SYSTEM (VTCS) DELAY VALVE REMOVAL/INSTALLATION [ZM] .....	01-13A-10
VARIABLE TUMBLE CONTROL SYSTEM (VTCS) DIAGRAM [FS].....	01-13B-13
VARIABLE TUMBLE CONTROL SYSTEM (VTCS) DIAGRAM [ZM] .....	01-13A-8
VARIABLE TUMBLE CONTROL SYSTEM (VTCS) SHUTTER VALVE ACTUATOR INSPECTION [FS].....	01-13B-14
VARIABLE TUMBLE CONTROL SYSTEM (VTCS) SHUTTER VALVE ACTUATOR INSPECTION [ZM] .....	01-13A-10
VARIABLE TUMBLE CONTROL SYSTEM (VTCS) SHUTTER VALVE ACTUATOR REMOVAL/INSTALLATION [FS] .....	01-13B-13
VARIABLE TUMBLE CONTROL SYSTEM (VTCS) SHUTTER VALVE ACTUATOR REMOVAL/INSTALLATION [ZM].....	01-13A-9
VARIABLE TUMBLE CONTROL SYSTEM (VTCS) SOLENOID VALVE INSPECTION [FS] .....	01-13B-15
VARIABLE TUMBLE CONTROL SYSTEM (VTCS) SOLENOID VALVE INSPECTION [ZM].....	01-13A-11
VEHICLE LIFT (2 SUPPORTS) AND SAFETY STAND (RIGID RACK) POSITION .....	00-00-22
VEHICLE SPEEDOMETER SENSOR (VSS) INSPECTION [ATX].....	05-17-27
VEHICLE SPEEDOMETER SENSOR (VSS) REMOVAL/INSTALLATION [ATX].....	05-17-28
VENTILATOR GRILLE REMOVAL/INSTALLATION .....	09-17-3

## W

WARM UP THREE-WAY CATALYTIC CONVERTER (WU-TWC) INSPECTION .....	01-16-19
WARNING AND INDICATOR LIGHT BULB REMOVAL/INSTALLATION .....	09-22-13

AI

## ALPHABETICAL INDEX

---

WASHER FLUID-LEVEL SENSOR INSPECTION . . . . .	09-19-8	WINDSHIELD MOLDING REMOVAL . . . . .	09-16-8
WASHER FLUID-LEVEL SENSOR REMOVAL/INSTALLATION . . . . .	09-19-8	WINDSHIELD REMOVAL . . . . .	09-12-19
WASHER HOSE (REAR) REMOVAL/INSTALLATION . . . . .	09-19-15	WINDSHIELD WASHER HOSE REMOVAL/INSTALLATION . . . . .	09-19-11
WASHER MOTOR (REAR) INSPECTION . . . . .	09-19-14	WINDSHIELD WASHER MOTOR INSPECTION . . . . .	09-19-8
WASHER MOTOR (REAR) REMOVAL/INSTALLATION . . . . .	09-19-14	WINDSHIELD WASHER MOTOR REMOVAL/INSTALLATION . . . . .	09-19-7
WASHER NOZZLE (REAR) ADJUSTMENT . . . . .	09-19-15	WINDSHIELD WASHER NOZZLE ADJUSTMENT . . . . .	09-19-10
WASHER NOZZLE (REAR) CLEANING . . . . .	09-19-15	WINDSHIELD WASHER NOZZLE CLEANING . . . . .	09-19-11
WASHER NOZZLE (REAR) REMOVAL/INSTALLATION . . . . .	09-19-14	WINDSHIELD WASHER NOZZLE INSTALLATION . . . . .	09-19-11
WASHER TANK REMOVAL/INSTALLATION . . . . .	09-19-7	WINDSHIELD WASHER NOZZLE REMOVAL . . . . .	09-19-11
WATER PUMP REMOVAL/INSTALLATION . . . . .	01-12-8	WINDSHIELD WIPER ARM AND BLADE ADJUSTMENT . . . . .	09-19-5
WHEEL (FRONT) ALIGNMENT . . . . .	02-11-1	WINDSHIELD WIPER ARM AND BLADE REMOVAL/INSTALLATION . . . . .	09-19-5
WHEEL (REAR) ALIGNMENT . . . . .	02-11-3	WINDSHIELD WIPER LINK REMOVAL/INSTALLATION . . . . .	09-19-5
WHEEL ALIGNMENT PRE-INSPECTION . . . . .	02-11-1	WINDSHIELD WIPER MOTOR INSPECTION . . . . .	09-19-6
WHEEL CYLINDER DISASSEMBLY/ASSEMBLY . . . . .	04-11-27	WINDSHIELD WIPER MOTOR REMOVAL/INSTALLATION . . . . .	09-19-6
WHEEL HUB BOLT REPLACEMENT . . . . .	03-11-2	WIPER AND WASHER SWITCH INSPECTION . . . . .	09-19-9
WHEEL HUB, HUB SPINDLE (DISC BRAKE TYPE) REMOVAL/INSTALLATION . . . . .	03-12-4	WIPER AND WASHER SWITCH REMOVAL/INSTALLATION . . . . .	09-19-9
WHEEL HUB, HUB SPINDLE (DRUM BRAKE TYPE) REMOVAL/INSTALLATION . . . . .	03-12-2	WIPER ARM AND BLADE (REAR) ADJUSTMENT . . . . .	09-19-12
WHEEL HUB, HUB SPINDLE PRE-INSPECTION . . . . .	03-12-1	WIPER ARM AND BLADE (REAR) REMOVAL/INSTALLATION . . . . .	09-19-12
WHEEL HUB, STEERING KNUCKLE PRE-INSPECTION . . . . .	03-11-1	WIPER MOTOR (REAR) INSPECTION . . . . .	09-19-13
WHEEL HUB, STEERING KNUCKLE REMOVAL/INSTALLATION . . . . .	03-11-3	WIPER MOTOR (REAR) REMOVAL/INSTALLATION . . . . .	09-19-12
WINDOW GLASS (REAR) INSTALLATION . . . . .	09-12-14	WIPER/WASHER SYSTEMS LOCATION INDEX . . . . .	09-19-2
WINDOW GLASS (REAR) REMOVAL . . . . .	09-12-11	WIPER/WASHER SYSTEMS WIRING DIAGRAM . . . . .	09-19-4
WINDOW GLASS MOLDING (REAR) INSTALLATION . . . . .	09-16-7		
WINDOW GLASS MOLDING (REAR) REMOVAL . . . . .	09-16-7		
WINDSHIELD INSTALLATION . . . . .	09-12-21		
WINDSHIELD MOLDING INSTALLATION . . . . .	09-16-8		

---

# Mazda Protegé Protegé 5

2002  
Wiring Diagram  
Supplement

**mazda**

## **WARNING**

**Servicing a vehicle can be dangerous. If you have not received service-related training, the risks of injury, property damage, and failure of servicing increase. The recommended servicing procedures for the vehicle in this workshop manual were developed with Mazda-trained technicians in mind. This manual may be useful to non-Mazda trained technicians, but a technician with our service-related training and experience will be at less risk when performing service operations. However, all users of this manual are expected at least to know general safety procedures.**

**This manual contains "Warnings" and "Cautions" applicable to risks not normally encountered in a general technician's experience. They should be followed to reduce the risk of injury and the risk that improper service or repair may damage the vehicle or render it unsafe. It is also important to understand that the "Warnings" and "Cautions" are not exhaustive. It is impossible to warn of all the hazardous consequences that might result from failure to follow the procedures.**

**The procedures recommended and described in this manual are effective methods of performing service and repair. Some require tools specifically designed for a specific purpose. Persons using procedures and tools which are not recommended by Mazda Motor Corporation must satisfy themselves thoroughly that neither personal safety nor safety of the vehicle will be jeopardized.**

**The contents of this manual, including drawings and specifications, are the latest available at the time of printing, and Mazda Motor Corporation reserves the right to change the vehicle designs and alter the contents of this manual without notice and without incurring obligation.**

**Parts should be replaced with genuine Mazda replacement parts or with parts which match the quality of genuine Mazda replacement parts. Persons using replacement parts of lesser quality than that of genuine Mazda replacement parts must satisfy themselves thoroughly that neither personal safety nor safety of the vehicle will be jeopardized.**

**Mazda Motor Corporation is not responsible for any problems which may arise from the use of this manual. The cause of such problems includes but is not limited to insufficient service-related training, use of improper tools, use of replacement parts of lesser quality than that of genuine Mazda replacement parts, or not being aware of any revision of this manual.**

# Mazda Protegé Protegé 5

## 2002 Wiring Diagram Supplement

### FOREWORD

This is a supplement to the following Wiring Diagram and covers only new major components not in the previous Wiring Diagrams.

Mazda Protegé / Protegé 5  
2002 Wiring Diagram  
Form No. 5520-1U-01G  
Part No. 9999-95-019G-02S

As all information in this supplement was the best available at the time of printing, all alterations related to modifications will be notified by Service Information.

**Mazda Motor Corporation  
HIROSHIMA, JAPAN**

### APPLICATION:

This manual applies to vehicles beginning with the Vehicle Identification Numbers (VIN) on the following page.

### CONTENTS

TITLE	Section
GROUND POINTS	Y
ELECTRICAL WIRING SCHEMATIC	W
SYSTEM CIRCUIT DIAGRAM/ CONNECTOR LOCATIONS	A-U
COMMON CONNECTORS	X
JOINT BOX COMPLETE WIRING SYSTEM	JB
FUSE BLOCK COMPLETE WIRING SYSTEM	FB
PARTS INDEX	PI

© 2002 Mazda Motor Corporation  
Form No. 5548-1U-02C  
Part No. 9999-95-019G-02S

**VEHICLE IDENTIFICATION NUMBER (VIN)  
(CHASSIS NUMBER)**

JM1 BJ222\*2# 596253—  
JM1 BJ224\*2# 596253—  
JM1 BJ225\*2# 596253—  
JM1 BJ226\*2# 596253—  
JM1 BJ245\*2# 596253—  
JM1 BJ246\*2# 596253—

**WIRING COLOR CODE**

<b>COLOR</b>	<b>CODE</b>	<b>COLOR</b>	<b>CODE</b>
BLACK	B	LIGHT GREEN	LG
BLUE	L	ORANGE	O
BROWN	BR	PINK	P
DARK BLUE	DL	RED	R
DARK GREEN	DG	SKY BLUE	SB
GRAY	GY	VIOLET	V
GREEN	G	WHITE	W
LIGHT BLUE	LB	YELLOW	Y

# SYSTEM INDEX

<b>GROUND POINT</b> .....	2	<b>EXTERIOR LIGHTING SYSTEM</b>	
<b>ELECTRICAL WIRING SCHEMATIC</b> .....	4	FRONT FOG LIGHT(4SD) .....	36
<b>ENGINE-RELATED SYSTEM</b>		TURN AND HAZARD WARNING LIGHT .....	38
CHARGING SYSTEM .....	6	BACK-UP LIGHT .....	40
STARTING SYSTEM .....	6	BRAKE LIGHT .....	42
ENGINE CONTROL SYSTEM		HIGH-MOUNT BRAKE LIGHT .....	42
ZM .....	8	<b>AIR CONDITIONING-RELATED SYSTEM</b>	
FS .....	18	HEATER AND AIR CONDITIONER .....	44
<b>CHASSIS-RELATED SYSTEM</b>		<b>ACCESSORY</b>	
EC-AT CONTROL SYSTEM		CIGARETTE LIGHTER .....	48
ZM .....	8	AUDIO SYSTEM .....	54
FS .....	18	<b>OTHER</b>	
SPORT AT CONTROL SYSTEM .....	46	DATA LINK CONNECTOR .....	60
<b>INSTRUMENT CLUSTER-RELATED SYSTEM</b>		<b>COMMON CONNECTOR LIST</b> .....	62
INSTRUMENT CLUSTER .....	28	<b>JOINT BOX COMPLETE WIRING SYSTEM</b> .....	64
<b>BODY-RELATED SYSTEM</b>		<b>FUSE BLOCK COMPLETE WIRING SYSTEM</b> .....	66
REAR WINDOW DEFROSTER .....	48	<b>PARTS INDEX</b> .....	68
POWER WINDOW SYSTEM .....	56		
POWER OUTSIDE MIRROR .....	58		
<b>INTERIOR LIGHTING SYSTEM</b>			
CARGO COMPARTMENT LIGHT(5HB) .....	48		
TRUNK COMPARTMENT LIGHT(4SD) .....	48		
ILLUMINATION LIGHT .....	50		



GROUND POINT

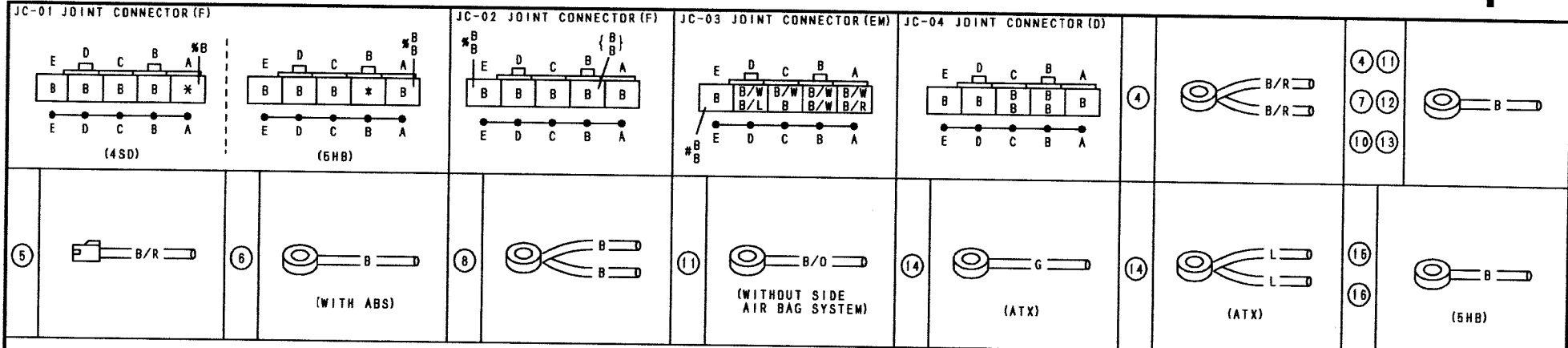

2

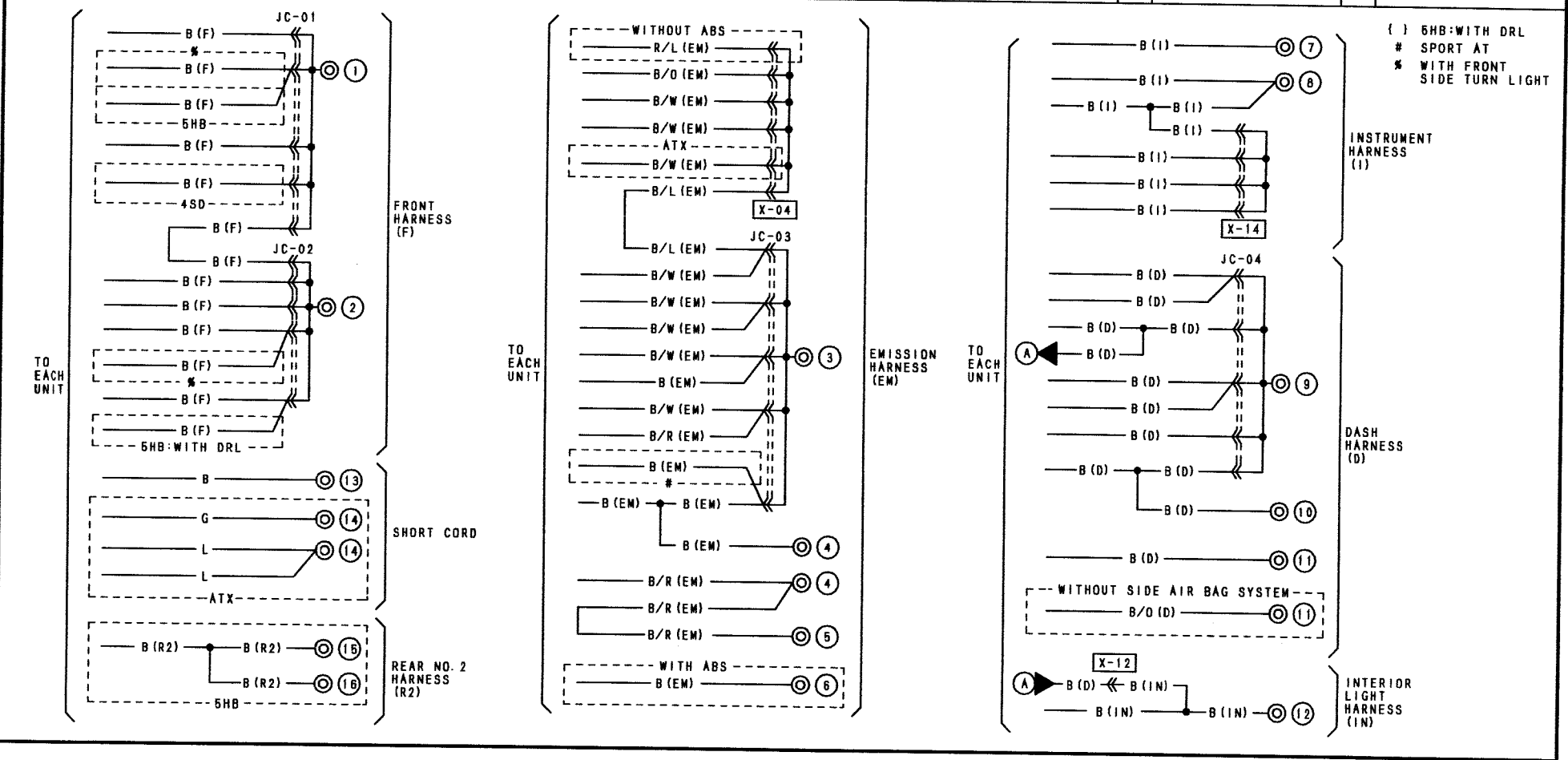

HARNESS SYMBOL :  (F)  (E)  (D)  (R)

3

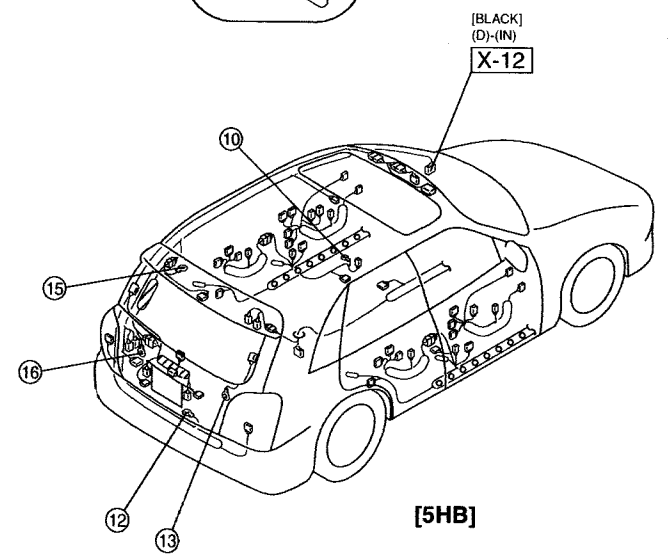
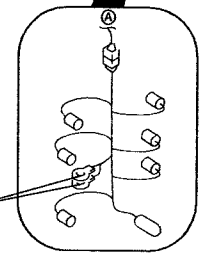
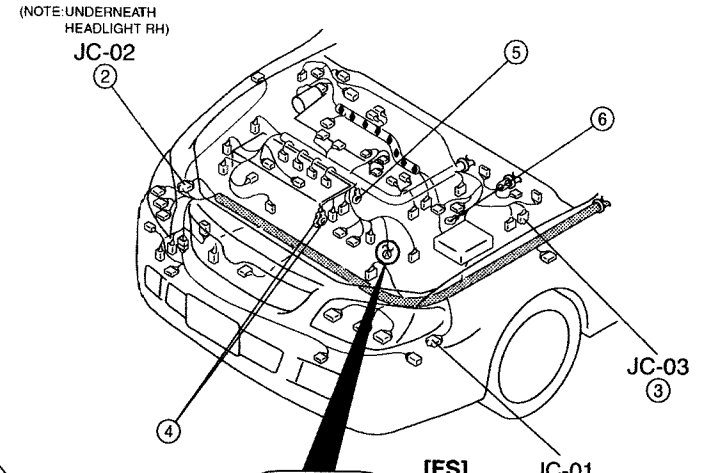
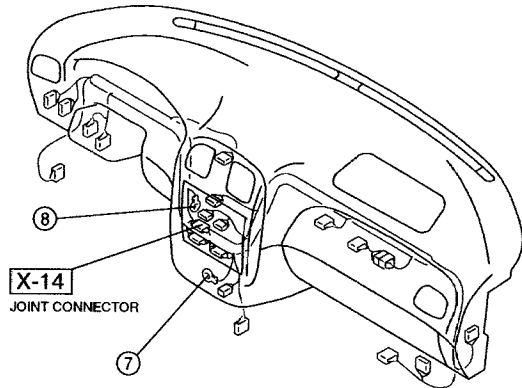
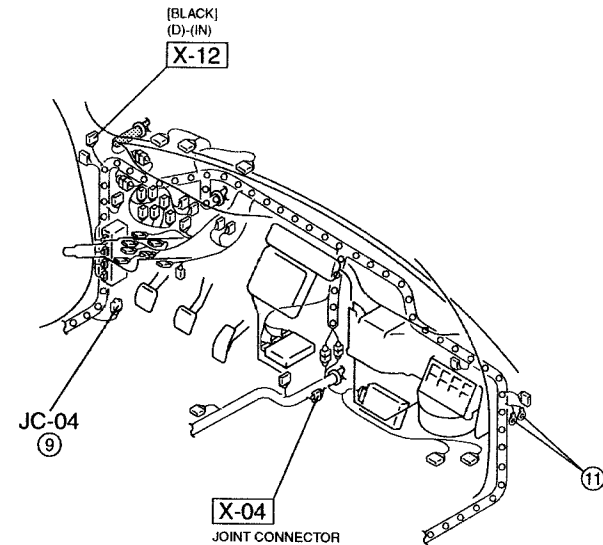
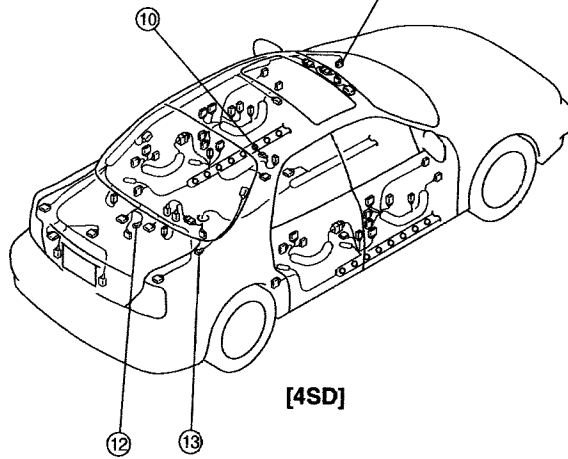
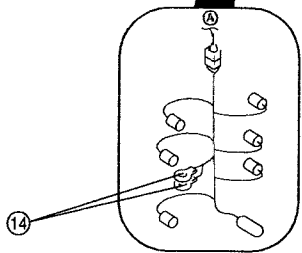
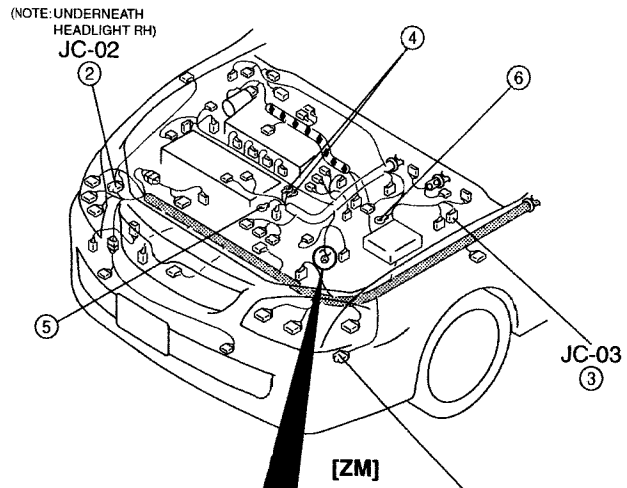

Y

# ELECTRICAL WIRING SCHEMATIC

W

——— CURRENT FROM BATTERY  
 - - - - - CURRENT FROM IG1 TERMINAL OF IGNITION SWITCH  
 - - - - - CURRENT FROM IG2 TERMINAL OF IGNITION SWITCH  
 - - - - - CURRENT FROM ACC TERMINAL OF IGNITION SWITCH  
 ——— OTHERS

4

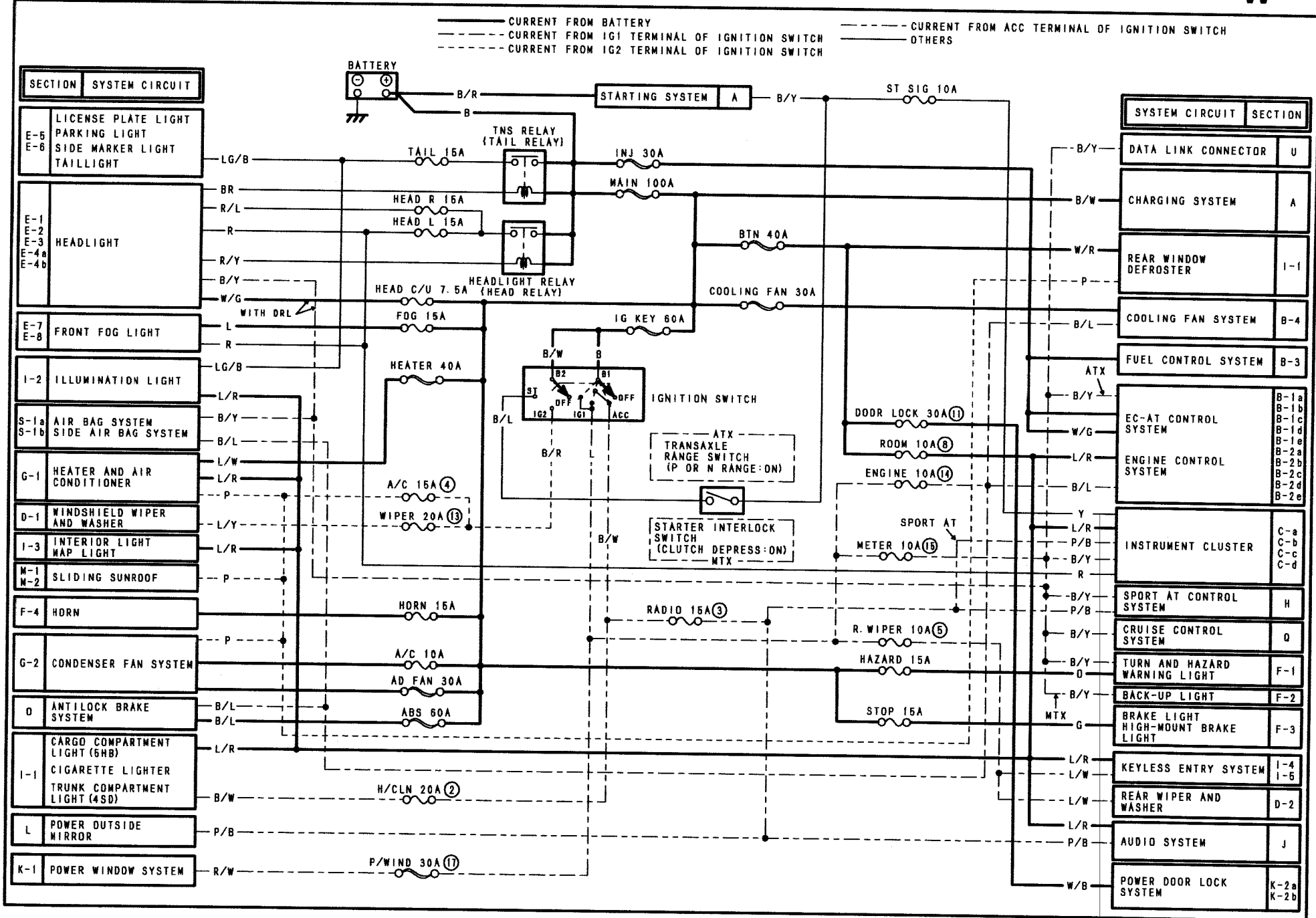

SECTION	SYSTEM CIRCUIT
---------	----------------

E-5 E-6	LICENSE PLATE LIGHT PARKING LIGHT SIDE MARKER LIGHT TAILLIGHT
------------	--

E-1 E-2 E-3 E-4a E-4b	HEADLIGHT
-----------------------------------	-----------

E-7 E-8	FRONT FOG LIGHT
------------	-----------------

I-2	ILLUMINATION LIGHT
-----	--------------------

S-1a S-1b	AIR BAG SYSTEM SIDE AIR BAG SYSTEM
--------------	---------------------------------------

G-1	HEATER AND AIR CONDITIONER
-----	-------------------------------

D-1	WINDSHIELD WIPER AND WASHER
-----	--------------------------------

I-3	INTERIOR LIGHT MAP LIGHT
-----	-----------------------------

M-1 M-2	SLIDING SUNROOF
------------	-----------------

F-4	HORN
-----	------

G-2	CONDENSER FAN SYSTEM
-----	----------------------

D	ANTILOCK BRAKE SYSTEM
---	--------------------------

I-1	CARGO COMPARTMENT LIGHT (6HB) CIGARETTE LIGHTER TRUNK COMPARTMENT LIGHT (4SD)
-----	---

L	POWER OUTSIDE MIRROR
---	-------------------------

K-1	POWER WINDOW SYSTEM
-----	---------------------

SYSTEM CIRCUIT	SECTION
----------------	---------

B/Y	DATA LINK CONNECTOR	U
-----	---------------------	---

B/W	CHARGING SYSTEM	A
-----	-----------------	---

W/R	REAR WINDOW DEFROSTER	I-1
-----	--------------------------	-----

P	COOLING FAN SYSTEM	B-4
---	--------------------	-----

B/L	FUEL CONTROL SYSTEM	B-3
-----	---------------------	-----

B/Y	EC-AT CONTROL SYSTEM	B-1a B-1b B-1c B-1d
-----	-------------------------	------------------------------

W/G	ENGINE CONTROL SYSTEM	B-1e B-2a B-2b B-2c B-2d B-2e
-----	--------------------------	--

L/R	INSTRUMENT CLUSTER	C-a C-b C-c C-d
-----	--------------------	--------------------------

B/Y	SPORT AT CONTROL SYSTEM	H
-----	----------------------------	---

P/B	CRUISE CONTROL SYSTEM	Q
-----	--------------------------	---

B/Y	TURN AND HAZARD WARNING LIGHT	F-1
-----	----------------------------------	-----

D	BACK-UP LIGHT	F-2
---	---------------	-----

B/Y	BRAKE LIGHT HIGH-MOUNT BRAKE LIGHT	F-3
-----	--	-----

MTX	KEYLESS ENTRY SYSTEM	I-4 I-5
-----	----------------------	------------

G	REAR WIPER AND WASHER	D-2
---	--------------------------	-----

L/R	AUDIO SYSTEM	J
-----	--------------	---

L/W	POWER DOOR LOCK SYSTEM	K-2a K-2b
-----	---------------------------	--------------

**THIS PAGE INTENTIONALLY  
LEFT BLANK**

# CHARGING SYSTEM / STARTING SYSTEM

A

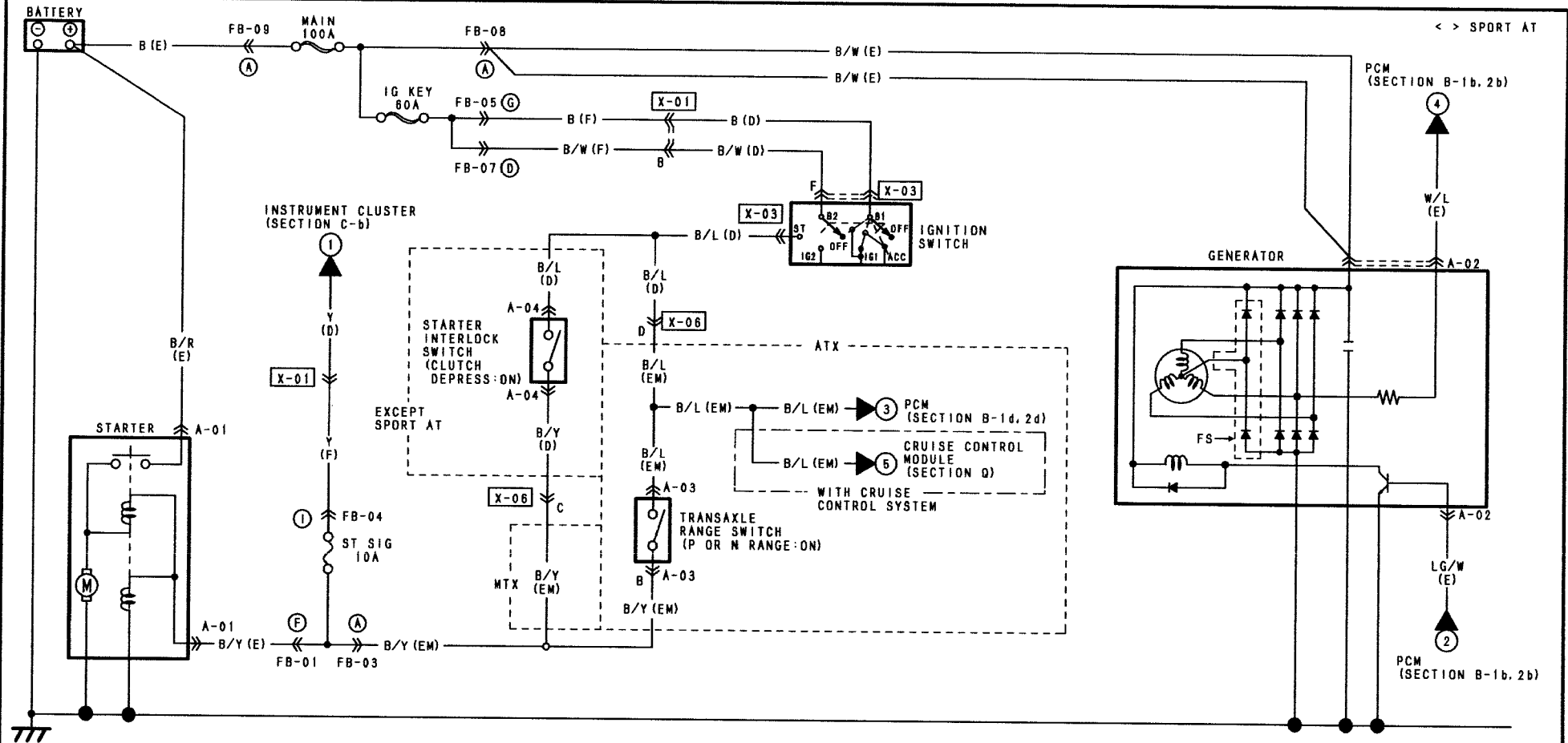

9

<p>A-01 STARTER (E)</p>	<p>A-02 GENERATOR (E)</p>	<p>A-03 TRANSAXLE RANGE SWITCH (EM)</p> <p>(ATX)</p>	<p>A-04 STARTER INTERLOCK SWITCH (D)</p> <p>(EXCEPT SPORT AT)</p>			
-------------------------	---------------------------	--	---	--	--	--

HARNESS SYMBOL :  (F)  (E)  (D)  (R)

**GENERATOR**  
 Generates power to keep battery fully charged and to operate vehicle's electrical system. Output is variable and depends on speed at which generator rotor spins, as well as amount of current passing through rotor winding.

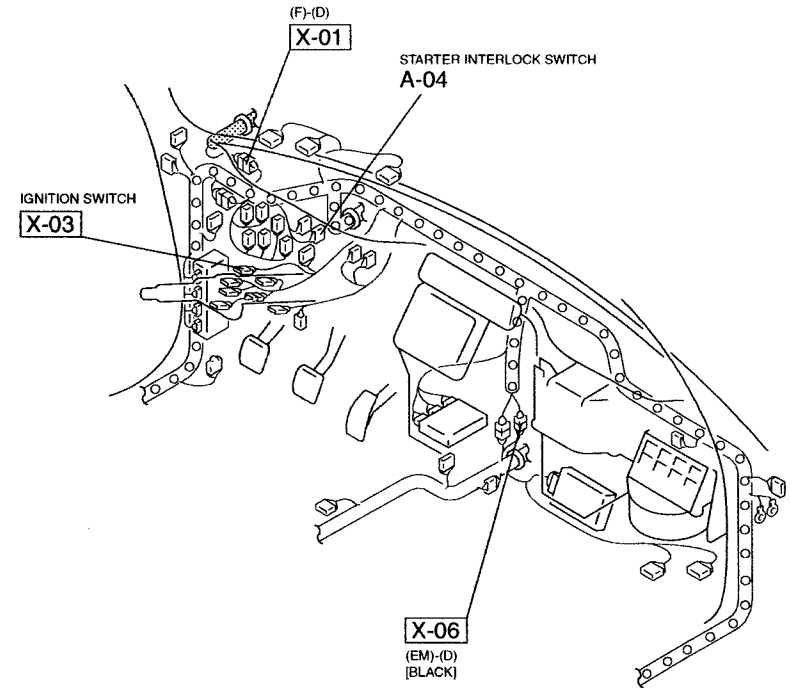
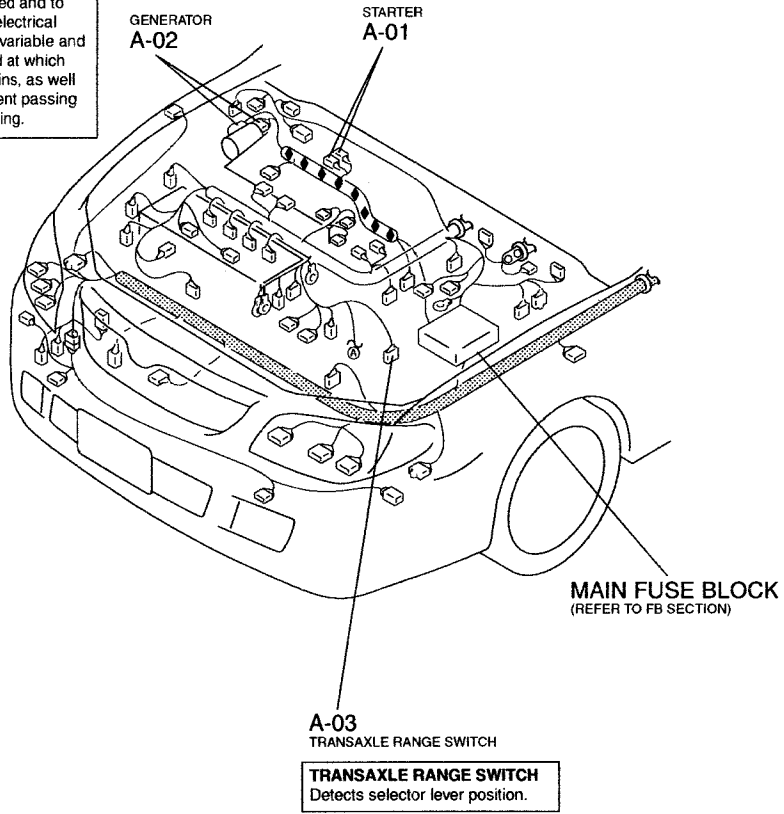

7

A

# EC-AT CONTROL SYSTEM (ZM) / ENGINE CONTROL SYSTEM (ZM)

B-1a

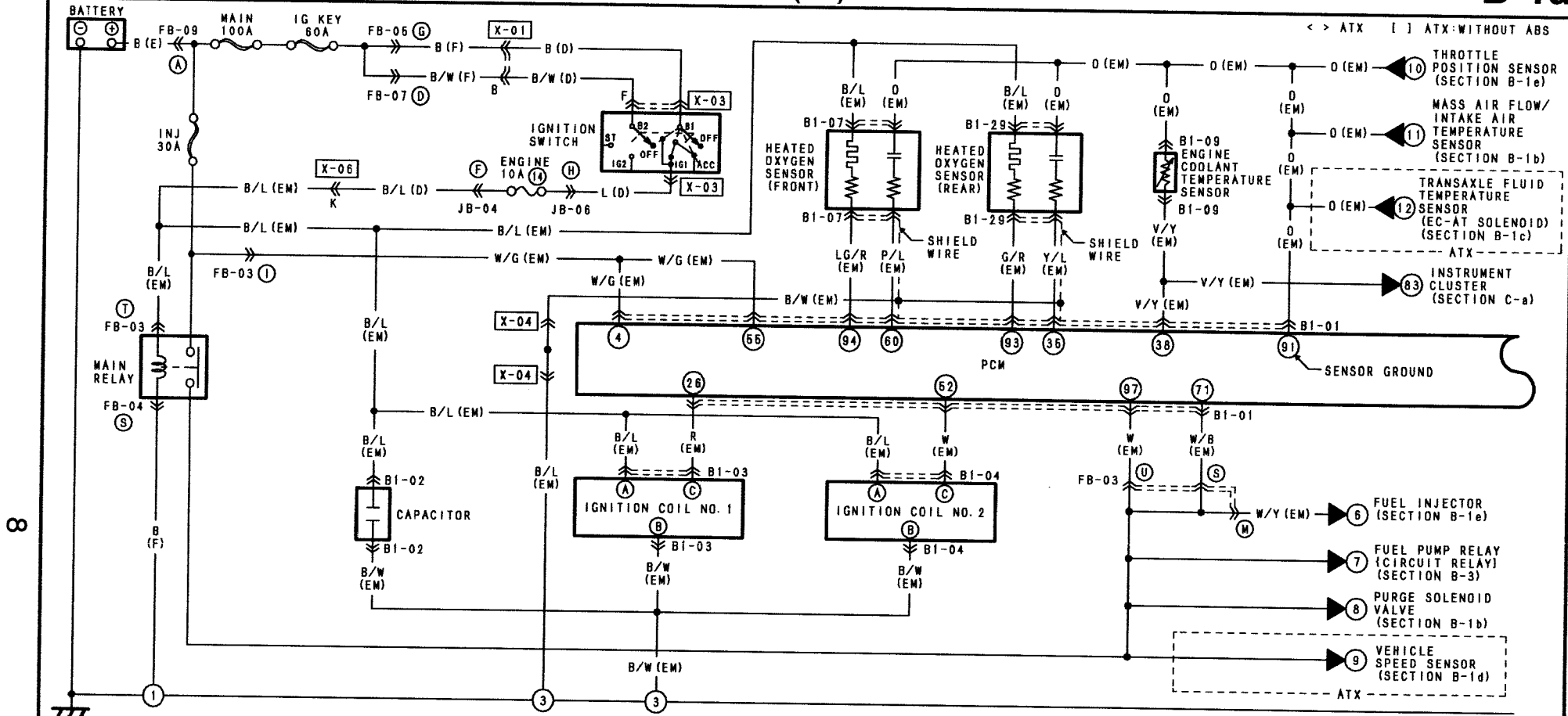

8

B1-01 PCM (EM)

26	25	24	23	22	21	20	19	18	17	16	15	14	13	12	11	10	9	8	7	6	5	4	3	2	1
R	*	B/W	<Y/B>	D/B	Y	*	L/R	Y	*	*	*	*	W/G	*	*	<L/Y>	*	<L/R>	W/G	BR/B	W/G	S	R/G	<B/O>	*
52	51	50	49	48	47	46	45	44	43	42	41	40	39	38	37	36	35	34	33	32	31	30	29	28	27
W	B/W	*	*	V/W	R/B	LG	G/W	KGY/L	Y/L	Y/B	G/B	*	L/W	V/Y	KR/W	*	Y/L	R/L	*	<R/Y>	B/W	W/L	<G/D>	[GY/B]	<Y/G>
78	77	76	75	74	73	72	71	70	69	68	67	66	65	64	63	62	61	60	59	58	57	56	55	54	53
*	B/W	B/W	B/R	B/Y	*	V/G	W/B	*	*	BR/W	BR/R	*	P/G	GY	R/B	*	P/L	*	G/R	*	P	W/G	BR	LG/W	
104	103	102	101	100	99	98	97	96	95	94	93	92	91	90	89	88	87	86	85	84	83	82	81	80	79
*	B/R	<BR/B>	L/D	G/B	<L/W>	GY/R	W	L/B	B/LG	LG/R	G/R	G/Y	D	P/B	BR/Y	LG/B	*	*	L	<Y/R>	GY	<P/L>	<L>	V	Y/G

B1-03 IGNITION COIL NO. 1 (EM)

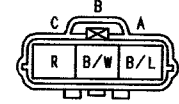

B1-04 IGNITION COIL NO. 2 (EM)

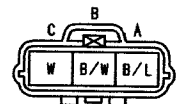

B1-29 HEATED OXYGEN SENSOR (REAR) (EM)

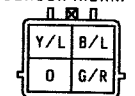

B1-02 CAPACITOR (EM)

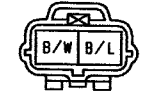

B1-07 HEATED OXYGEN SENSOR (FRONT) (EM)

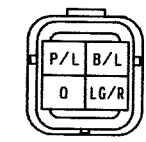

B1-09 ENGINE COOLANT TEMPERATURE SENSOR (EM)

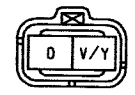

HARNESS SYMBOL :  (F)  (E)  (D)  (R)

6

**IGNITION COIL**  
Provides high voltage pulse to spark plugs.

(GRAY) IGNITION COIL NO.2  
**B1-04**

(GRAY) IGNITION COIL NO.1  
**B1-03**

**ENGINE COOLANT TEMPERATURE SENSOR**  
Detects engine coolant temperature and sends signal to PCM.

ENGINE COOLANT TEMPERATURE SENSOR  
**B1-09**

**B1-02**  
CAPACITOR  
[BLACK]

**B1-07**  
HEATED OXYGEN SENSOR (FRONT)  
[BLACK]

**HEATED OXYGEN SENSOR**  
Upstream side to catalytic converter:  
Detects exhaust gas condition (Air/Fuel ratio) and sends signal to PCM.  
Downstream side to catalytic converter:  
Detects deterioration of catalytic converter.

**B1-29**  
HEATED OXYGEN SENSOR (REAR)  
[GRAY]

**MAIN FUSE BLOCK**  
(REFER TO FB SECTION)

**JOINT BOX**  
(REFER TO JB SECTION)

**IGNITION SWITCH**  
**X-03**

(F)-(D)  
**X-01**

**PCM**  
Uses information from various sensors/actuators to control powertrain (engine/transaxle) operation.

PCM  
**B1-01**

**X-04**  
JOINT CONNECTOR

**X-06**  
(EM)-(D)  
[BLACK]



# EC-AT CONTROL SYSTEM (ZM) / ENGINE CONTROL SYSTEM (ZM)

B-1b

< > ATX [ ] ATX-WITHOUT ABS

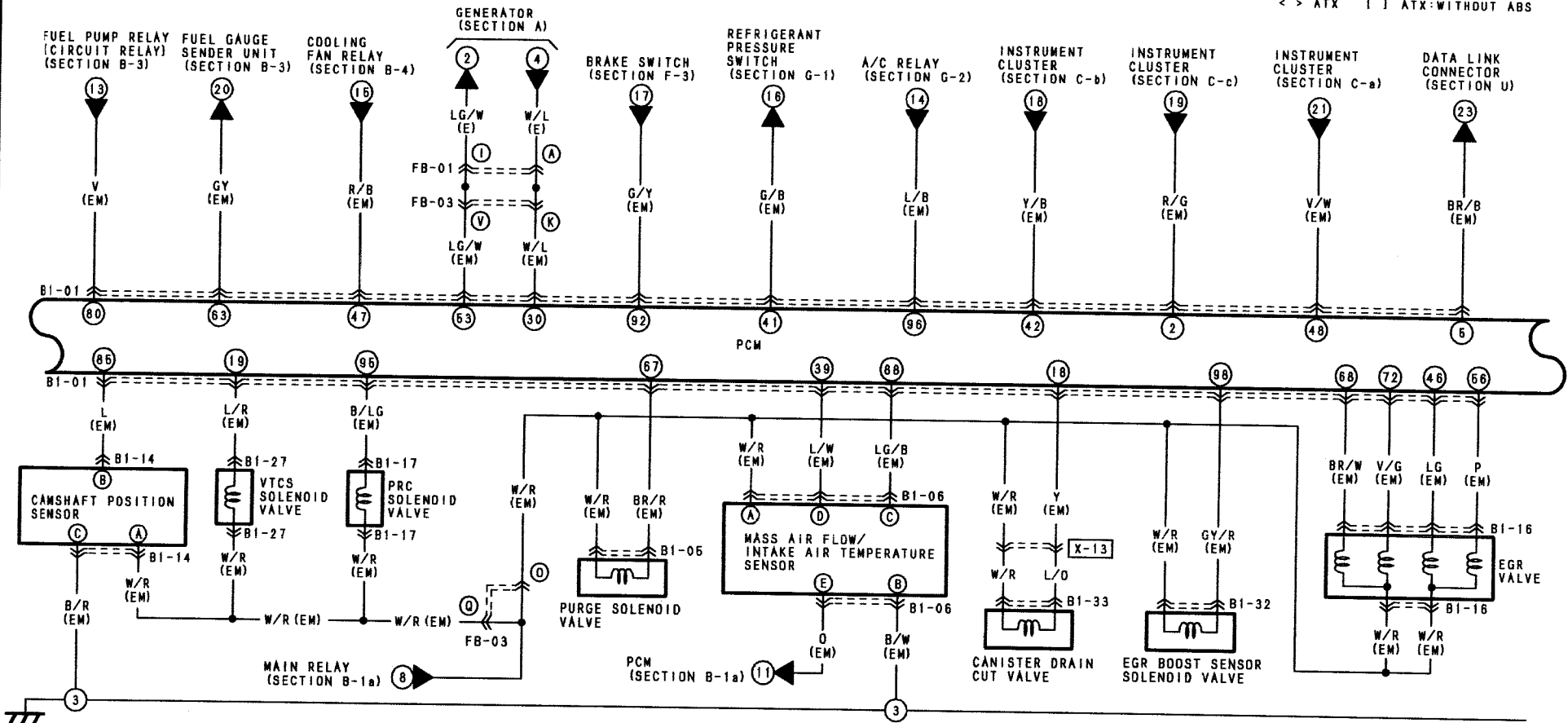

10

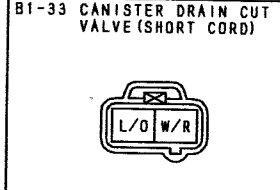
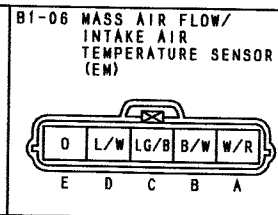
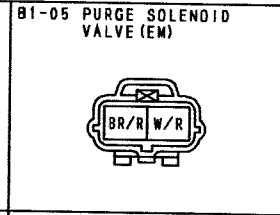
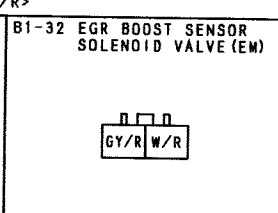
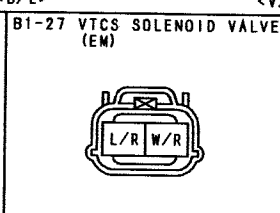
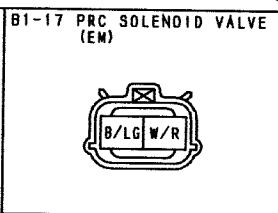
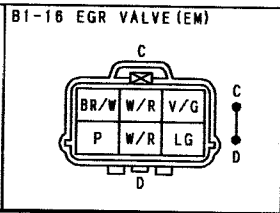
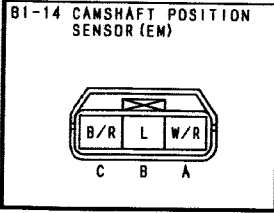

B1-01 PCM (EM)

24	25	23	22	21	20	19	18	17	16	15	14	13	12	11	10	9	8	7	6	5	4	3	2	1	
R	*	B/W<Y/B>	D/B	Y	*	L/R	Y	*	*	*	*	W/G	*	*	<L/Y>	*	<L/R>	W/G	BR/B	W/G	*	R/G	K/B	O	
62	61	60	48	47	46	45	44	43	42	41	40	39	38	37	36	35	34	33	32	31	30	28	27		
W	B/W	*	Y	W/R	B	LG	G/W	KGY/L	Y/L	Y/B	G/B	L/W	V/Y	<R/W>	*	Y/L	R/L	*	<R/Y>	B/W	W/L	K/G	O	IGY/B	<Y/G>
78	77	76	74	73	72	71	70	69	68	67	66	65	64	63	62	61	60	58	57	56	55	54	53		
*	B/W	B/W	B/R	B/Y	*	Y/G	W/B	*	BR	W/BR	*	P/G	GY	R/B	*	P/L	*	G/R	*	P	W/G	BR	LG	W	
164	163	162	161	160	99	98	97	96	95	94	93	92	91	90	89	88	87	86	85	84	83	82	81	80	78
*	B/R	KBR/B	L/D	G/B	<L/W>	GY/R	W	L/B	B/LG	LG/R	G/R	G/Y	O	P/B	BR/Y	LG/B	*	*	L	<Y/R>	GY	<P/L>	<L>	Y	Y/G



HARNES SYMBOL :  (F)  (E)  (D)  (R)

**CAMSHAFT POSITION SENSOR**  
 Uses the magnetic pickup sensor.  
 Detects camshaft position and  
 sends signal to PCM.

[GRAY]  
 CAMSHAFT POSITION SENSOR  
**B1-14**

VTCS SOLENOID VALVE  
**B1-27**

[BLACK]  
 EGR BOOST SENSOR SOLENOID VALVE  
**B1-32**

PRC SOLENOID VALVE  
**B1-17**

[BLACK]  
 PURGE SOLENOID VALVE  
**B1-05**

**MASS AIR FLOW SENSOR**  
 Detects mass air flow amount and  
 sends signal to PCM.

**INTAKE AIR TEMPERATURE SENSOR**  
 Detects intake air temperature and sends  
 signal to PCM.

MASS AIR FLOW/INTAKE AIR  
 TEMPERATURE SENSOR  
**B1-06**

**PCM**  
 Uses information from various sensors/  
 actuators to control powertrain (engine/  
 transaxle) operation.

PCM  
**B1-01**

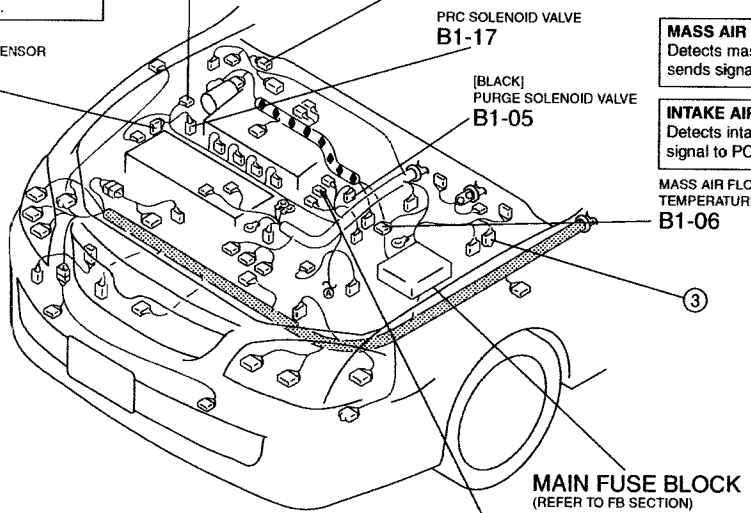

**MAIN FUSE BLOCK**  
 (REFER TO FB SECTION)

**B1-16**  
 EGR VALVE  
 [GRAY]  
 (NOTE:BELOW THROTTLE BODY)

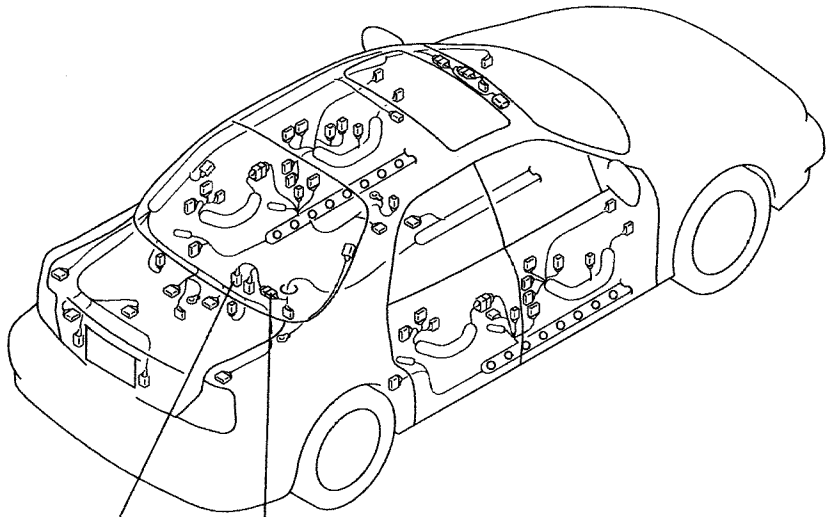
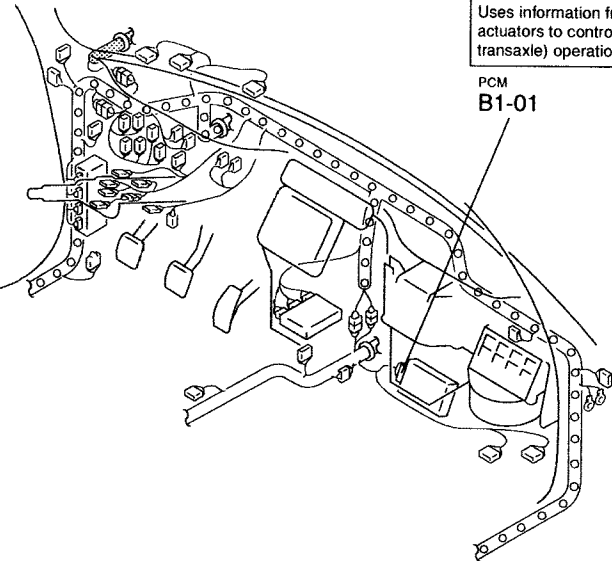

**B1-33**  
 CANISTER DRAIN CUT VALVE  
 [BLACK]

**X-13**  
 (EM)-SHORT CORD

11

# EC-AT CONTROL SYSTEM (ZM) / ENGINE CONTROL SYSTEM (ZM)

B-1c

12

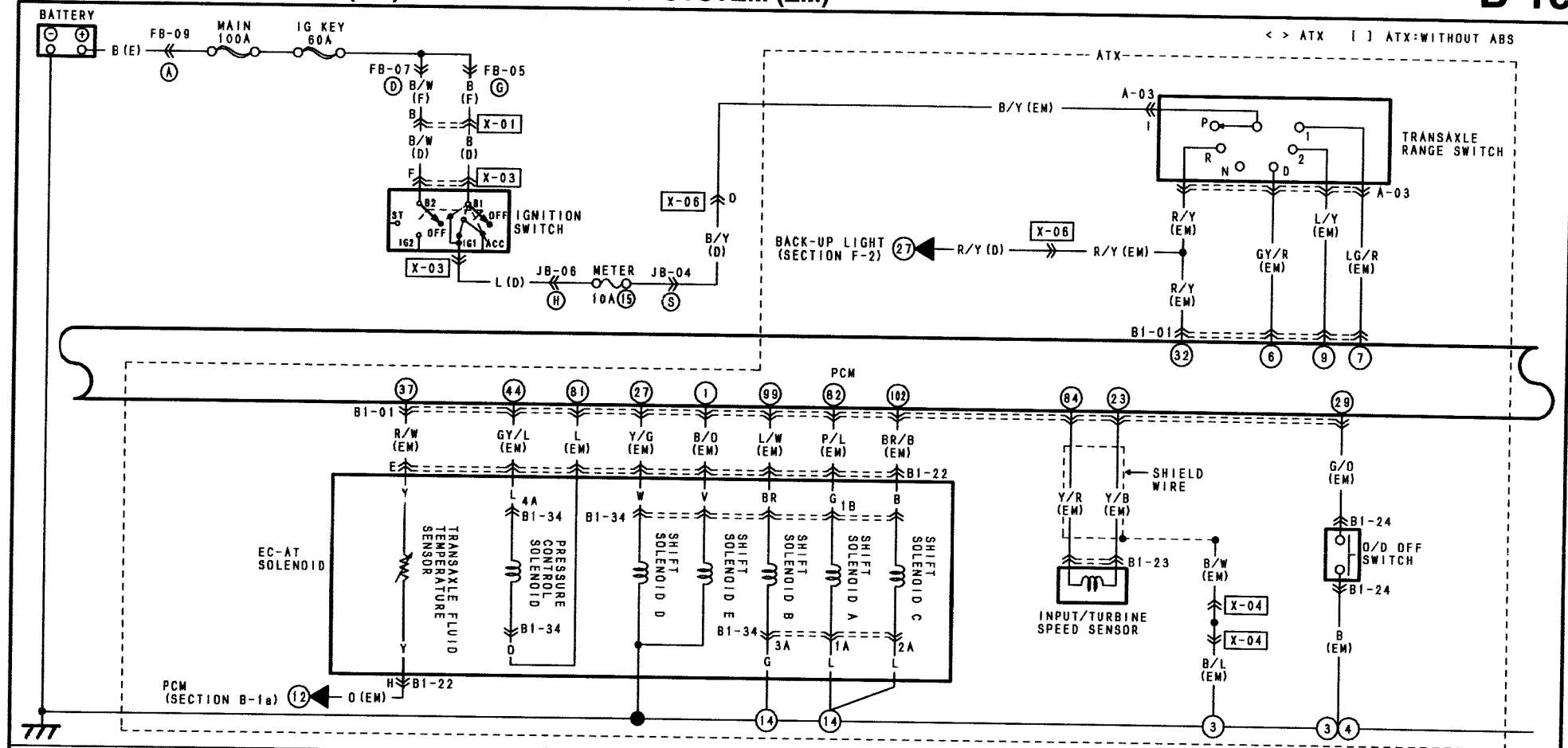

B1-01 PCM (EM)

24	26	25	24	23	22	21	20	19	18	17	16	15	14	13	12	11	10	9	8	7	6	5	4	3	2	1	*
62	R	*	B/W	<Y/B>	D/B	Y	*	L/R	Y	*	*	*	*	W/G	*	*	<L/Y>	*	<L/R>	W/G	BR/B	W/G	*	R/G	K/B	O	*
78	62	61	60	49	48	47	46	45	44	43	42	41	40	39	38	37	36	35	34	33	32	31	30	29	28	27	*
*	W	B/W	*	*	V/W	R/B	LG	G/W	KGY/L	Y/L	Y/B	G/B	*	L/W	V/Y	<R/W>	*	Y/L	R/L	*	<R/Y>	B/W	W/L	<G/O>	<GY/B>	<Y/G>	*
104	78	77	76	75	74	73	72	71	70	69	68	67	66	65	64	63	62	61	60	59	58	57	56	55	54	53	*
*	B/W	B/W	B/R	B/Y	*	V/G	W/B	*	BR/W	BR/R	*	*	*	P/G	GY	R/B	*	P/L	*	G/R	*	P	W/G	BR	LG	W	*
104	103	102	101	100	99	98	97	96	95	94	93	92	91	90	89	88	87	86	85	84	83	82	81	80	79	78	*
*	B/R	<BR/B>	L/O	G/B	<L/W>	GY/R	W	L/B	B/LG	LG/R	G/R	G/Y	*	O	P/B	BR/Y	LG/B	*	*	L	<Y/R>	GY	<P/L>	<L>	V	Y/G	*

<G/Y/R>      <B/L>      <V/R>

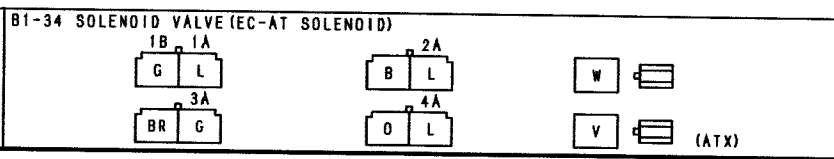
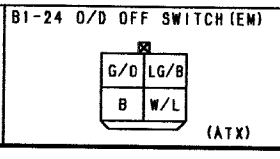
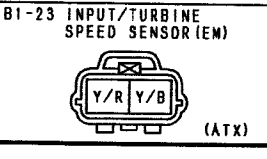
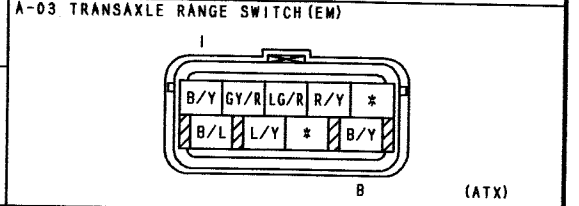
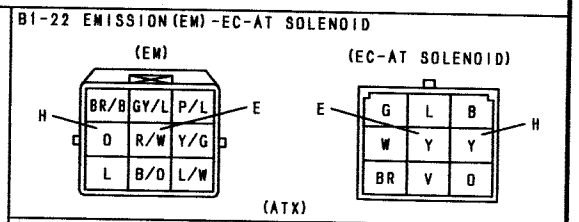

13

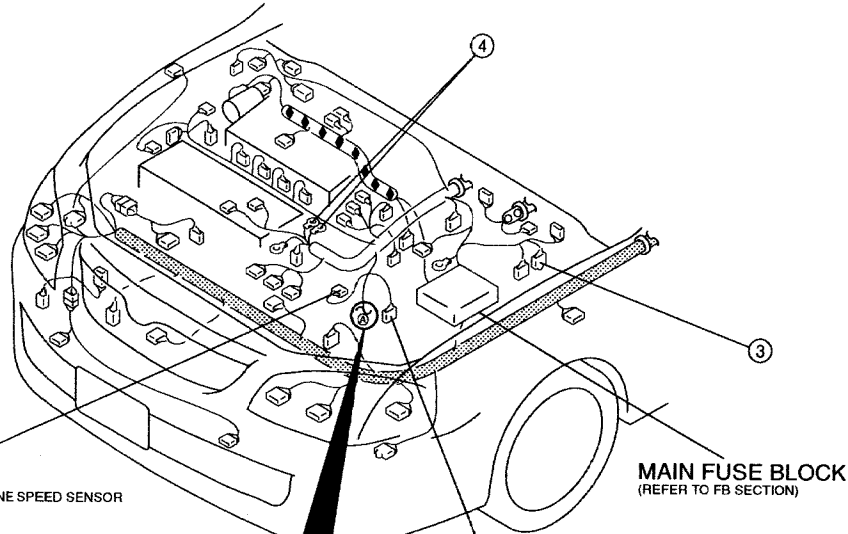

**B1-23**  
INPUT/TURBINE SPEED SENSOR  
[GRAY]

**MAIN FUSE BLOCK**  
(REFER TO FB SECTION)

**INPUT/TURBINE SPEED SENSOR**  
The frequency from this sensor supplies the PCM with turbine shaft speed signal. This signal is used in determining line pressure and torque converter engagement schedules.

**A-03**  
TRANSAXLE RANGE SWITCH

**TRANSAXLE RANGE SWITCH**  
Detects selector lever position.

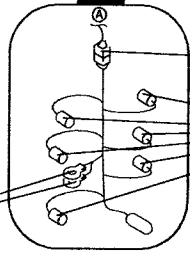

**B1-22**  
(EM)-EC-AT SOLENOID

**B1-34**  
SOLENOID VALVE  
(INSIDE OF TRANSAXLE)

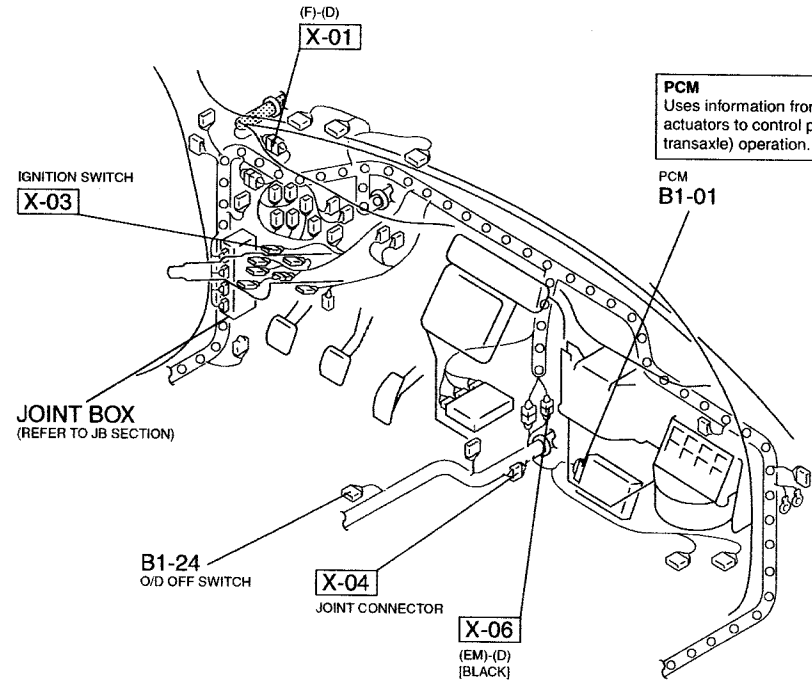

**IGNITION SWITCH**  
X-03

(F)-(D)  
X-01

**PCM**  
Uses information from various sensors/actuators to control powertrain (engine/transaxle) operation.

**PCM**  
B1-01

**JOINT BOX**  
(REFER TO JB SECTION)

**B1-24**  
O/D OFF SWITCH

X-04  
JOINT CONNECTOR

X-06  
(EM)-(D)  
[BLACK]

# EC-AT CONTROL SYSTEM (ZM) / ENGINE CONTROL SYSTEM (ZM)

B-1d

14

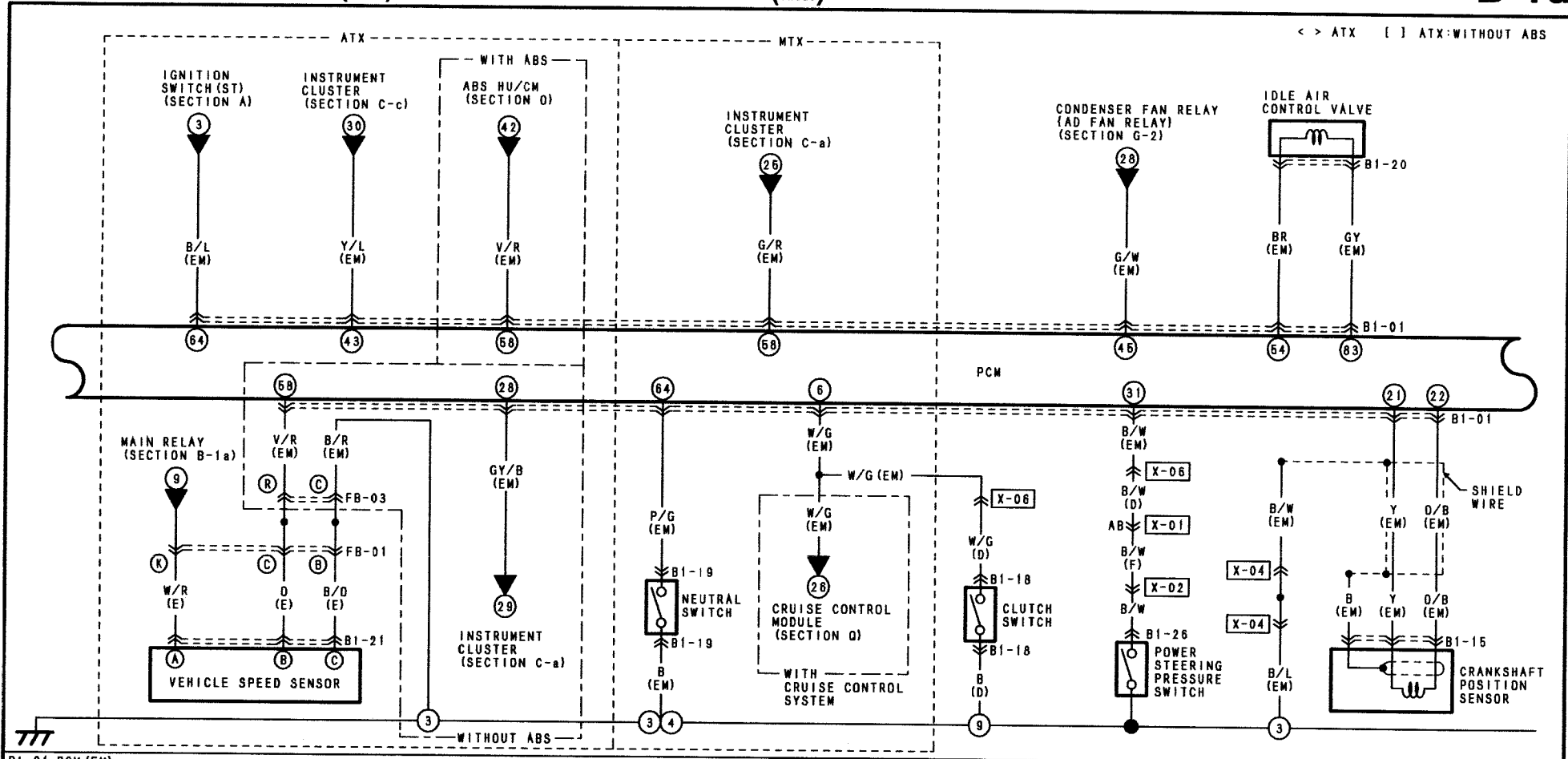

B1-01 PCM (EM)

24	26	25	24	23	22	21	20	19	18	17	16	15	14	13	12	11	10	9	8	7	6	5	4	3	2	1	*
R	*	B/W	<Y/B>	O/B	Y	*	L/R	Y	*	*	*	*	*	W/G	*	<L/Y>	*	<L/R>	W/G	BR/B	W/G	*	R/G	<B/O>	*	*	
51	51	50	48	48	47	46	45	44	43	42	41	40	*	59	58	57	56	55	54	53	52	51	50	49	48	47	46
W	B/W	*	*	V/W	R/B	LG	G/W	<G/L>	<Y/L>	Y/B	G/B	*	*	L/W	V/Y	<R/W>	*	Y/L	R/L	*	<R/Y>	B/W	W/L	<G/D>	<G/Y>	<Y/G>	
78	77	76	75	74	73	72	71	70	69	68	67	66	*	65	64	63	62	61	60	59	58	57	56	55	54	53	52
*	B/W	B/W	B/R	B/Y	*	V/G	W/B	*	BR/W	BR/R	*	*	*	P/G	GY	R/B	*	P/L	*	G/R	*	P	W/G	BR	LG	W	79
104	103	102	101	100	99	98	97	96	95	94	93	92	*	91	90	89	88	87	86	85	84	83	82	81	80	79	
*	B/R	<B/B>	L/D	G/B	<L/W>	<G/Y>	W	L/B	B/LG	LG/R	G/R	G/Y	*	O	P/B	BR/Y	LG/B	*	*	L	<Y/R>	GY	<P/L>	<L>	V	Y/G	

B1-15 CRANKSHAFT POSITION SENSOR (EM)

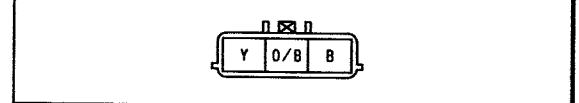

B1-18 CLUTCH SWITCH (D)

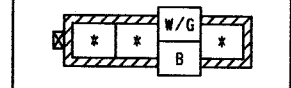

B1-19 NEUTRAL SWITCH (EM)

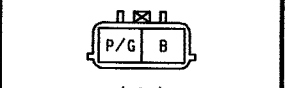

B1-20 IDLE AIR CONTROL VALVE (EM)



B1-21 VEHICLE SPEED SENSOR (E)

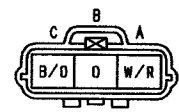

B1-26 POWER STEERING PRESSURE SWITCH (SHORT CORD)



(ATX)

(MTX)

HARNESS SYMBOL :  (F)  (E)  (D)  (R)

**CRANKSHAFT POSITION SENSOR**  
 Uses the magnetic pickup sensor.  
 Detects crankshaft position and sends signal to PCM.

[GRAY]  
 CRANKSHAFT POSITION SENSOR  
 B1-15

**VEHICLE SPEED SENSOR**  
 Mounted on the transaxle or transmission, this sensor generates a signal that is proportional to vehicle speed and sends this signal to PCM.

[GRAY]  
 VEHICLE SPEED SENSOR  
 B1-21

X-02  
 (F)-SHORT CORD

B1-26  
 POWER STEERING PRESSURE SWITCH

**POWER STEERING PRESSURE SWITCH**  
 Power steering pressure switch signals PCM to increase idle speed to prevent engine from stalling.

B1-20  
 IDLE AIR CONTROL VALVE

B1-19  
 NEUTRAL SWITCH  
 [GRAY]

**NEUTRAL SWITCH**  
 Opened when gear is in neutral position or clutch pedal is depressed. Sends signal to PCM, ABS control module.

MAIN FUSE BLOCK  
 (REFER TO FB SECTION)

**CLUTCH SWITCH**  
 Opened with clutch pedal depressed, Sends signal to PCM, ABS control module.

(F)-(D)  
 X-01  
 [BLACK]  
 CLUTCH SWITCH  
 B1-18

**PCM**  
 Uses information from various sensors/actuators to control powertrain (engine/transaxle) operation.

PCM  
 B1-01

X-04  
 JOINT CONNECTOR

X-06  
 (EM)-(D)  
 [BLACK]

15

# EC-AT CONTROL SYSTEM (ZM) / ENGINE CONTROL SYSTEM (ZM)

B-1e

16

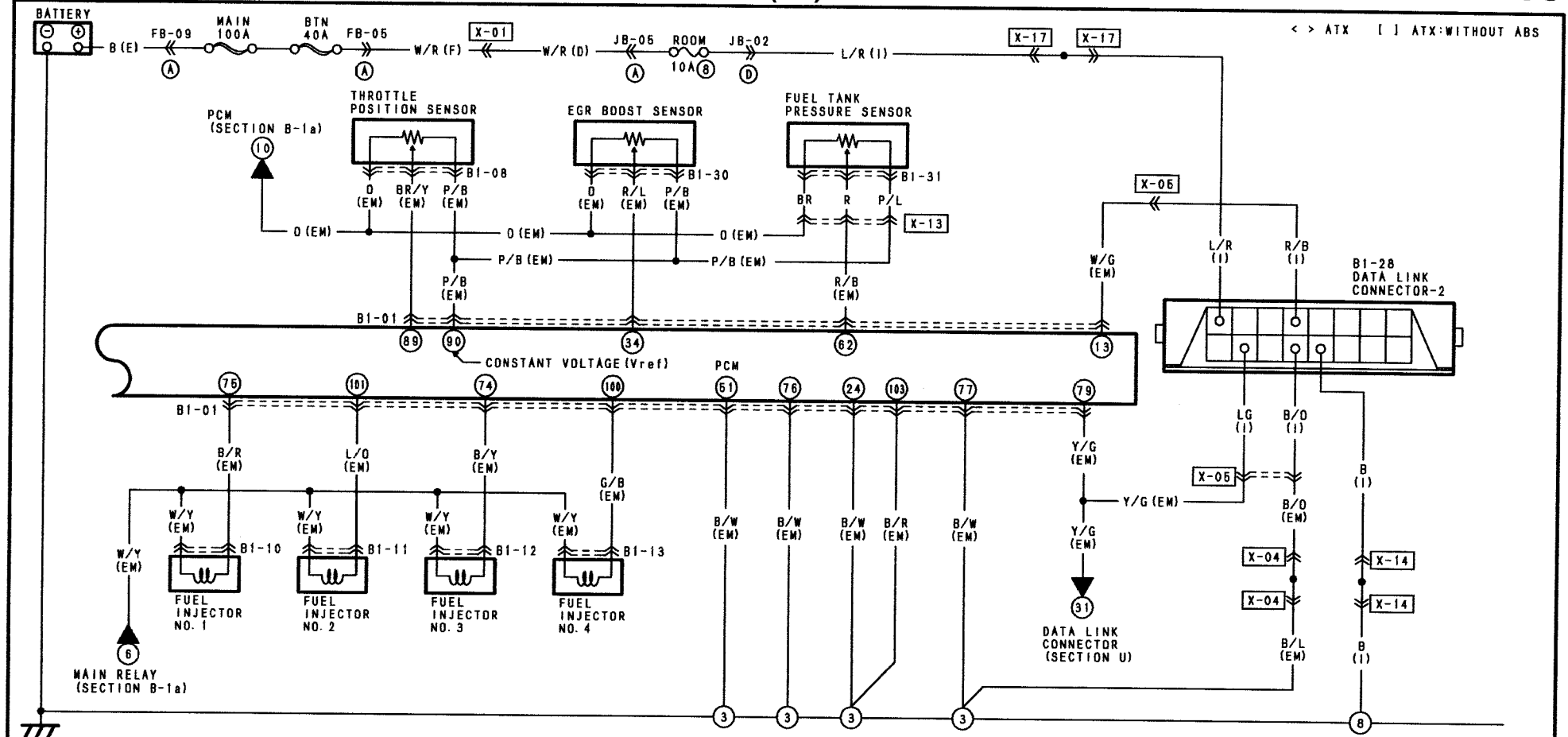

B1-01 PCM (EM)

24	26	25	24	23	22	21	20	19	18	17	16	15	14	13	12	11	10	9	8	7	6	5	4	3	2	1
	R	*	B/W	<Y/B>	D/B	Y	*	L/R	Y	*	*	*	*	W/G	W/G	BR/B	W/G	*	R/G	<B/O>	*					
51	62	51	50	49	48	47	46	45	44	43	42	41	40	39	38	37	36	35	34	33	32	31	30	29	28	27
	W	B/W	*	V/W	R/B	LG	G/W	GY/L	<Y/L>	Y/B	G/B	*		L/W	V/Y	R/W	*	Y/L	R/L	*	<R/Y>	B/W	W/L	<G/B>	[GY/B]	<Y/G>
78	77	76	75	74	73	72	71	70	69	68	67	66	65	64	63	62	61	60	59	58	57	56	55	54	53	
	*	B/W	B/W	B/R	B/Y	*	V/G	W/B	*	BR/W	BR/R	*		P/G	GY	R/B	*	P/L	*	G/R	*	P	W/G	BR	LG/W	
104	103	102	101	100	99	98	97	96	95	94	93	92	91	90	89	88	87	86	85	84	83	82	81	80	79	
	*	B/R	<B/B>	L/D	G/B	<L/W>	GY/R	W	L/B	B/LG	LG/R	G/R	G/Y	O	P/B	BR/Y	LG/B	*	*	L	<Y/R>	GY	<P/L>	<L>	V	Y/G

<p>B1-08 THROTTLE POSITION SENSOR (EM)</p>	<p>B1-10 FUEL INJECTOR NO. 1 (EM)</p>
<p>B1-11 FUEL INJECTOR NO. 2 (EM)</p>	<p>B1-12 FUEL INJECTOR NO. 3 (EM)</p>
<p>B1-13 FUEL INJECTOR NO. 4 (EM)</p>	<p>B1-30 EGR BOOST SENSOR (EM)</p>
<p>B1-28 DATA LINK CONNECTOR-2 (1)</p>	<p>B1-31 FUEL TANK PRESSURE SENSOR (SHORT CORD)</p>

NOTE: THIS IS THE CONNECTOR AS SEEN FROM THE TERMINAL SIDE.

HARNESS SYMBOL :  (F)  (E)  (D)  (R)

**FUEL INJECTOR**  
Controlled by PCM  
meters fuel to engine.

[GRAY]  
FUEL INJECTOR NO.1  
B1-10

[GRAY]  
FUEL INJECTOR NO.2  
B1-11

[BLACK]  
EGR BOOST SENSOR  
B1-30

[GRAY]  
FUEL INJECTOR NO.3  
B1-12

[GRAY]  
FUEL INJECTOR NO.4  
B1-13

[GRAY]  
THROTTLE POSITION SENSOR  
B1-08

**THROTTLE POSITION SENSOR**  
Detects throttle opening angle and  
sends signal to PCM.

**MAIN FUSE BLOCK**  
(REFER TO FB SECTION)

DATA LINK CONNECTOR-2  
B1-28

X-14  
JOINT CONNECTOR

X-17  
JOINT CONNECTOR

X-05  
(EM)-(I)

(F)-(D)  
X-01

**PCM**  
Uses information from various sensors/  
actuators to control powertrain (engine/  
transaxle) operation.

PCM  
B1-01

**JOINT BOX**  
(REFER TO JB SECTION)

X-05  
(EM)-(I)

X-04  
JOINT CONNECTOR

(EM)-SHORT CORD  
X-13

**FUEL TANK PRESSURE SENSOR**  
Detects fuel tank pressure and sends  
signal to PCM. This signal is used for  
evaporative system monitoring.

B1-31  
FUEL TANK PRESSURE SENSOR  
[BLACK]



EC-AT CONTROL SYSTEM (FS) / ENGINE CONTROL SYSTEM (FS)

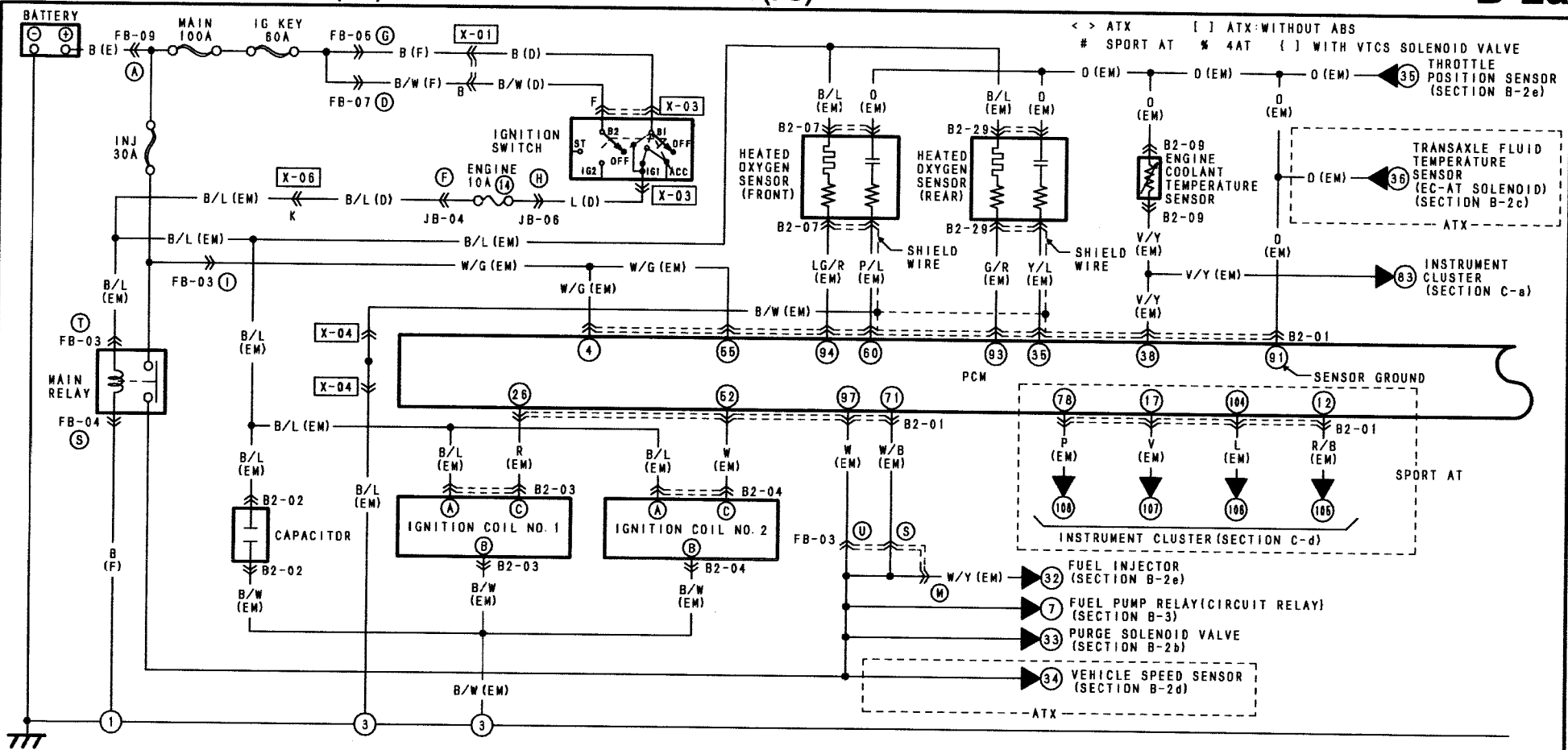

**B2-01 PCM (EM)**

26	25	24	23	22	21	20	19	18	17	16	15	14	13	12	11	10	9	8	7	6	5	4	3	2	1			
R	*	B/W	*Y/B	O/B	Y	#L/B	L/R	Y	#V	*	*	*	W/G	R/B	*	*	#L/Y	#L/G	R/L	W/G	BR/B	W/G	#L/G	R/G	K/B	O		
52	51	50	49	48	47	46	45	44	43	42	41	40	39	38	37	36	35	34	33	32	31	30	29	28	27			
W	B/W	*	*	V/W	R/B	LG	G/W	K/G	L/Y	Y/B	G/B	*	L/W	V/Y	K/R	W	Y/L	R/L	*	K/R	Y/B	W/L	#G/O	I/G	B/K	Y/G		
78	77	76	75	74	73	72	71	70	69	68	67	66	65	64	63	62	61	60	59	58	57	56	55	54	53			
#P	B/W	B/W	B/R	B/Y	{P}	V/G	W/B	*	#	BR	BR	R	*	P/G	GY	R/B	*	P/L	R	G/R	Y/L	P	W/G	BR	LG	W		
104	103	102	101	100	99	98	97	96	95	94	93	92	91	90	89	88	87	86	85	84	A3	82	81	80	79			
#L	B/R	BR/B	L/O	G/B	K/L	W/G	Y/R	W	L/B	B/LG	LG/R	G/R	G/Y	O	P/B	BR	Y/LG	B	*	G	L	K/Y	R	GY	K/P	L	V	Y/G

<B/L>    <V/R>

**B2-03 IGNITION COIL NO. 1 (EM)**

**B2-04 IGNITION COIL NO. 2 (EM)**

**B2-29 HEATED OXYGEN SENSOR (REAR) (EM)**

**B2-02 CAPACITOR (EM)**

**B2-07 HEATED OXYGEN SENSOR (FRONT) (EM)**

**B2-09 ENGINE COOLANT TEMPERATURE SENSOR (EM)**

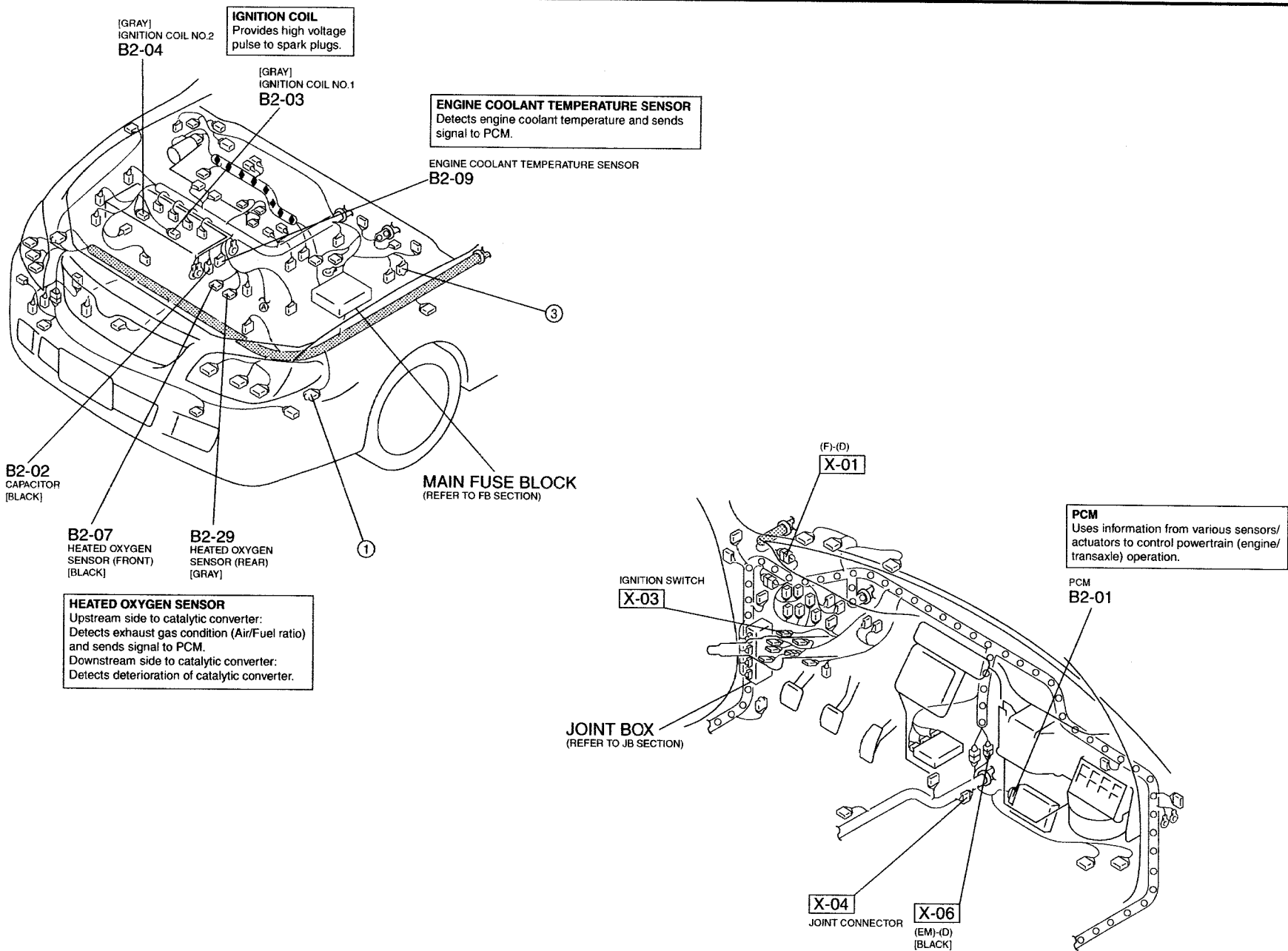

# EC-AT CONTROL SYSTEM (FS) / ENGINE CONTROL SYSTEM (FS)

B-2b

< > ATX [ ] ATX:WITHOUT ABS \* 4AT  
( ) WITH VTCS SOLENOID VALVE # SPORT AT

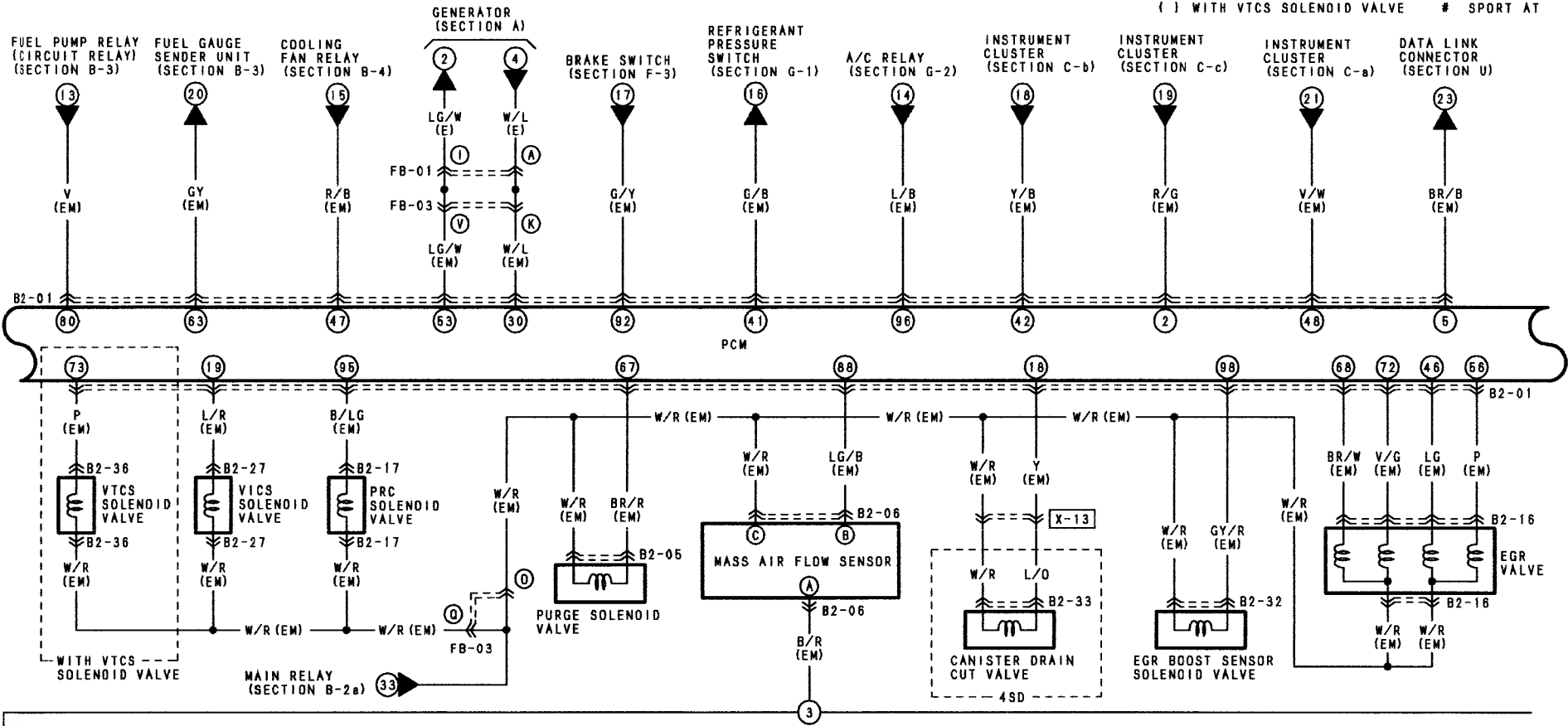

20

777

<p>B2-01 PCM (EM)</p> <table border="1"> <tr> <td>26</td><td>25</td><td>24</td><td>23</td><td>22</td><td>21</td><td>20</td><td>19</td><td>18</td><td>17</td><td>16</td><td>15</td><td>14</td><td>13</td><td>12</td><td>11</td><td>10</td><td>9</td><td>8</td><td>7</td><td>6</td><td>5</td><td>4</td><td>3</td><td>2</td><td>1</td><td>*</td> </tr> <tr> <td>R</td><td>*</td><td>B/W</td><td>K/Y/B</td><td>O/B</td><td>Y</td><td>#L/B</td><td>L/R</td><td>Y</td><td>#V</td><td>*</td><td>*</td><td>*</td><td>W/G</td><td>#R/B</td><td>*</td><td>*</td><td>#L/Y</td><td>#L/R</td><td>#L/R</td><td>W/G</td><td>BR/B</td><td>W/G</td><td>#L/G</td><td>R/G</td><td>K/B/O</td><td>*</td> </tr> <tr> <td>52</td><td>51</td><td>50</td><td>48</td><td>48</td><td>47</td><td>46</td><td>45</td><td>44</td><td>43</td><td>42</td><td>41</td><td>40</td><td>39</td><td>38</td><td>37</td><td>36</td><td>35</td><td>34</td><td>33</td><td>32</td><td>31</td><td>30</td><td>29</td><td>28</td><td>27</td><td>*</td> </tr> <tr> <td>76</td><td>77</td><td>76</td><td>75</td><td>74</td><td>73</td><td>72</td><td>71</td><td>70</td><td>69</td><td>68</td><td>67</td><td>66</td><td>65</td><td>64</td><td>63</td><td>62</td><td>61</td><td>60</td><td>59</td><td>58</td><td>57</td><td>56</td><td>55</td><td>54</td><td>53</td><td>*</td> </tr> <tr> <td>#P</td><td>B/W</td><td>B/W</td><td>B/R</td><td>B/Y</td><td>P</td><td>V/G</td><td>W/B</td><td>*</td><td>BR/W</td><td>BR/R</td><td>*</td><td>*</td><td>*P/G</td><td>GY</td><td>R/B</td><td>*</td><td>P/L</td><td>R</td><td>G/R</td><td>Y/L</td><td>P</td><td>W/G</td><td>BR</td><td>LG/W</td><td></td><td></td> </tr> <tr> <td>104</td><td>103</td><td>102</td><td>101</td><td>100</td><td>98</td><td>98</td><td>97</td><td>96</td><td>95</td><td>94</td><td>93</td><td>92</td><td>91</td><td>90</td><td>89</td><td>88</td><td>87</td><td>86</td><td>85</td><td>84</td><td>83</td><td>82</td><td>81</td><td>80</td><td>79</td><td></td> </tr> <tr> <td>#L</td><td>B/R</td><td>KBR/B</td><td>L/O</td><td>G/B</td><td>K/L/W</td><td>GY/R</td><td>W</td><td>L/B</td><td>B/LG</td><td>LG/R</td><td>G/R</td><td>G/Y</td><td></td><td></td><td></td><td></td><td></td><td></td><td></td><td></td><td></td><td></td><td></td><td></td><td></td><td></td> </tr> </table>		26	25	24	23	22	21	20	19	18	17	16	15	14	13	12	11	10	9	8	7	6	5	4	3	2	1	*	R	*	B/W	K/Y/B	O/B	Y	#L/B	L/R	Y	#V	*	*	*	W/G	#R/B	*	*	#L/Y	#L/R	#L/R	W/G	BR/B	W/G	#L/G	R/G	K/B/O	*	52	51	50	48	48	47	46	45	44	43	42	41	40	39	38	37	36	35	34	33	32	31	30	29	28	27	*	76	77	76	75	74	73	72	71	70	69	68	67	66	65	64	63	62	61	60	59	58	57	56	55	54	53	*	#P	B/W	B/W	B/R	B/Y	P	V/G	W/B	*	BR/W	BR/R	*	*	*P/G	GY	R/B	*	P/L	R	G/R	Y/L	P	W/G	BR	LG/W			104	103	102	101	100	98	98	97	96	95	94	93	92	91	90	89	88	87	86	85	84	83	82	81	80	79		#L	B/R	KBR/B	L/O	G/B	K/L/W	GY/R	W	L/B	B/LG	LG/R	G/R	G/Y															<p>B2-05 PURGE SOLENOID VALVE (EM)</p>	<p>B2-06 MASS AIR FLOW SENSOR (EM)</p>
26	25	24	23	22	21	20	19	18	17	16	15	14	13	12	11	10	9	8	7	6	5	4	3	2	1	*																																																																																																																																																																						
R	*	B/W	K/Y/B	O/B	Y	#L/B	L/R	Y	#V	*	*	*	W/G	#R/B	*	*	#L/Y	#L/R	#L/R	W/G	BR/B	W/G	#L/G	R/G	K/B/O	*																																																																																																																																																																						
52	51	50	48	48	47	46	45	44	43	42	41	40	39	38	37	36	35	34	33	32	31	30	29	28	27	*																																																																																																																																																																						
76	77	76	75	74	73	72	71	70	69	68	67	66	65	64	63	62	61	60	59	58	57	56	55	54	53	*																																																																																																																																																																						
#P	B/W	B/W	B/R	B/Y	P	V/G	W/B	*	BR/W	BR/R	*	*	*P/G	GY	R/B	*	P/L	R	G/R	Y/L	P	W/G	BR	LG/W																																																																																																																																																																								
104	103	102	101	100	98	98	97	96	95	94	93	92	91	90	89	88	87	86	85	84	83	82	81	80	79																																																																																																																																																																							
#L	B/R	KBR/B	L/O	G/B	K/L/W	GY/R	W	L/B	B/LG	LG/R	G/R	G/Y																																																																																																																																																																																				
<p>B2-16 EGR VALVE (EM)</p>	<p>B2-17 PRC SOLENOID VALVE (EM)</p>	<p>B2-27 VICS SOLENOID VALVE (EM)</p>	<p>B2-32 EGR BOOST SENSOR SOLENOID VALVE (EM)</p>	<p>B2-33 CANISTER DRAIN CUT VALVE (SHORT CORD)</p>	<p>B2-36 VTCS SOLENOID VALVE (EM)</p>																																																																																																																																																																																											

HARNES SYMBOL :  (F)  (E)  (D)  (R)

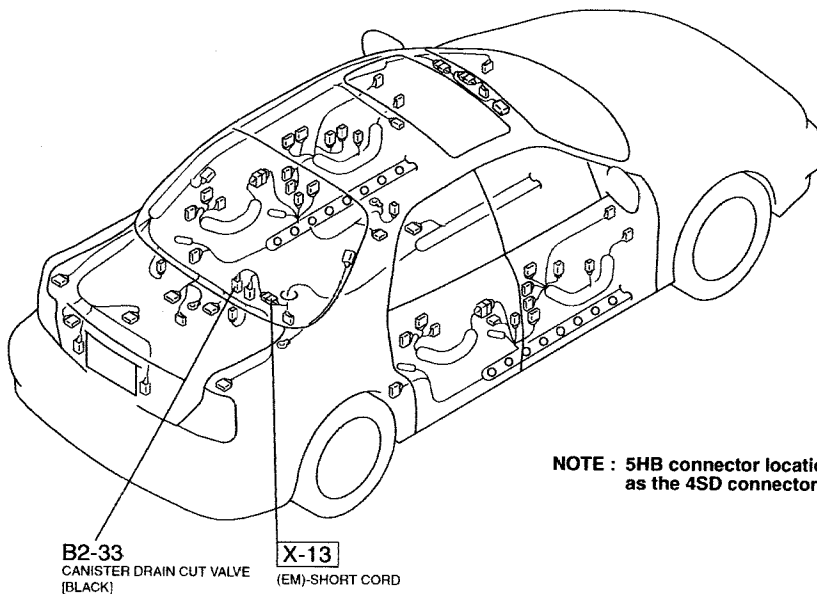
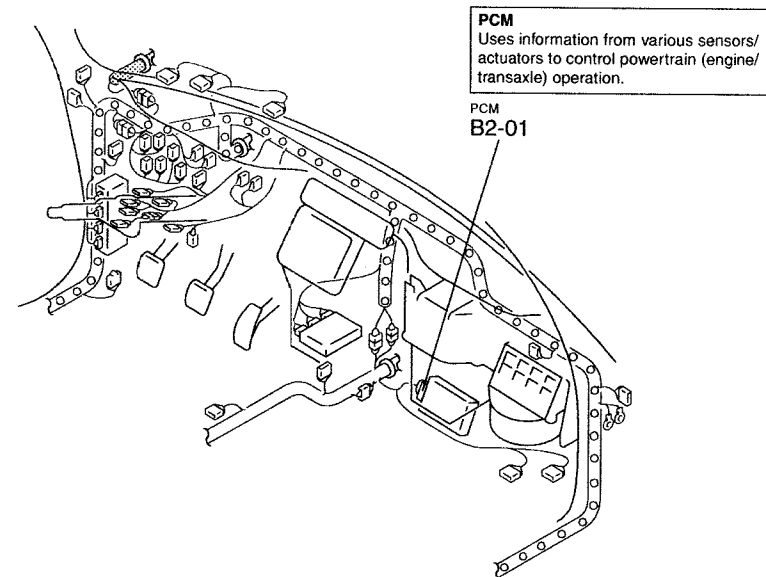
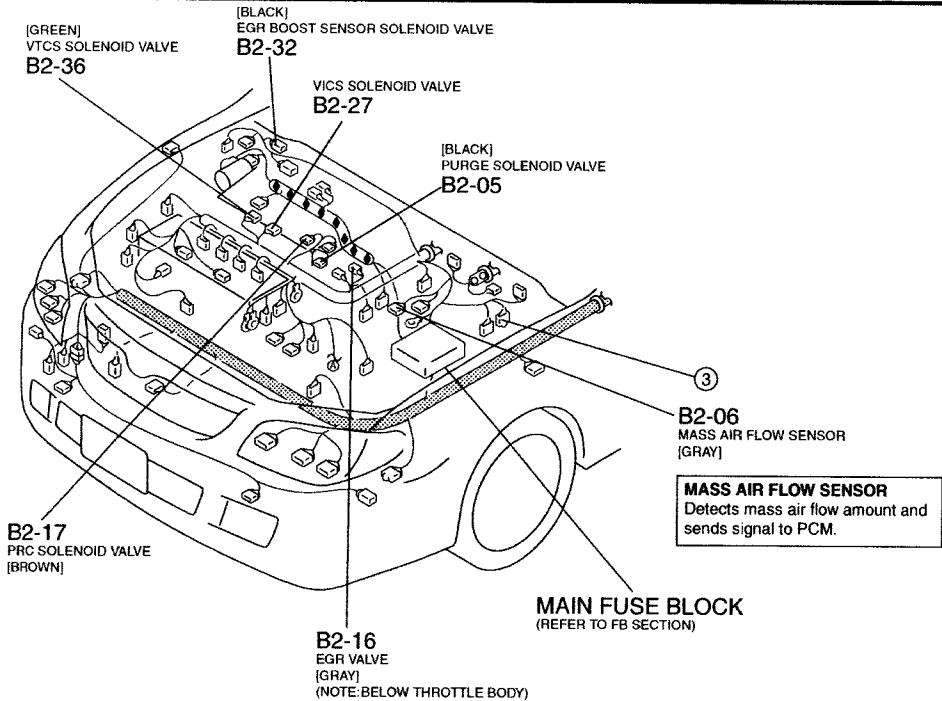

**NOTE :** 5HB connector locations are almost the same as the 4SD connector locations.

EC-AT CONTROL SYSTEM (FS) / ENGINE CONTROL SYSTEM (FS)

22

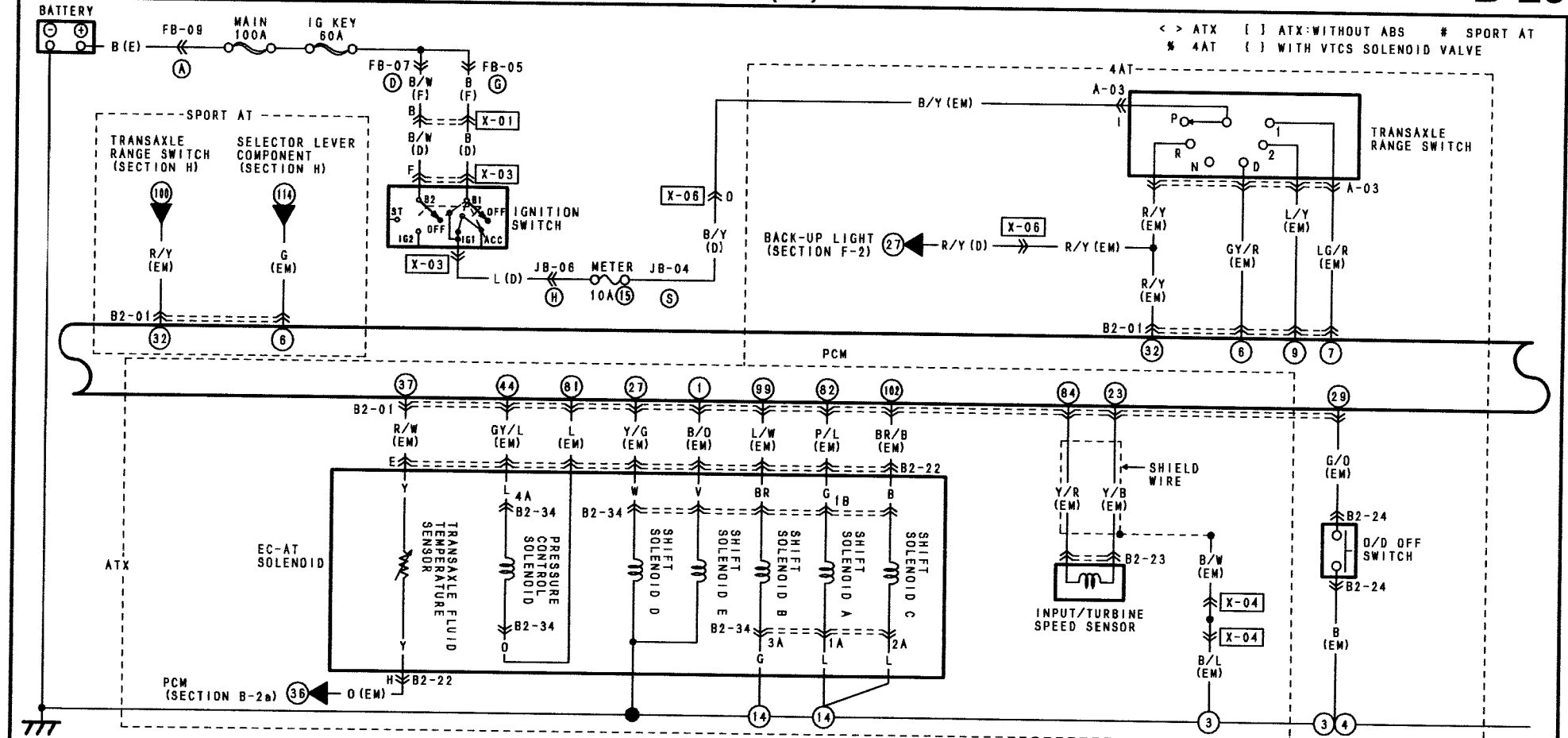

< > ATX [ ] ATX:WITHOUT ABS # SPORT AT  
\* 4AT ( ) WITH VTCS SOLENOID VALVE

B2-01 PCM (EM)

24	26	25	24	23	22	21	20	19	18	17	16	15	14	13	12	11	10	9	8	7	6	5	4	3	2	1
R	*	B/W	KY/B	O/B	B	Y	#L/B	L/R	Y	#V	*	*	*	W/G	#R/B	*	*	#L/Y	#LG/R	#LG/R	W/G	BR/B	W/G	#LG	R/G	K/B/O
51	51	60	48	48	47	46	45	44	43	42	41	40	39	38	37	36	35	34	33	32	31	30	29	28	27	*
W	B/W	*	*	V/W	R/B	LG	G/W	KGY/L	BY/L	Y/B	G/B	*	L/W	V/Y	<R/W>	*	Y/L	R/L	33	<R/Y>	B/W	W/L	#G/O	[GY/B]	[Y/G]	
78	77	76	75	74	73	72	71	70	68	68	67	66	65	64	63	62	61	60	58	56	57	56	55	54	53	*
#P	B/W	B/W	B/R	B/Y	(P)	V/G	W/B	*	*	BR/W	BR/R	*	* P/G	GY	R/B	*	P/L	R	G/R	Y/L	P	W/G	BR	LG	W	79
104	103	102	101	100	98	96	97	96	96	96	94	93	92	91	90	88	88	87	86	85	84	83	82	81	80	*
#L	B/R	KBR/B	L/O	G/B	K/L/W	GY/R	W	L/B	B/LG	LG/R	G/R	G/Y	O	P/B	BR/Y	LG/B	*	G	L	[Y/R]	GY	<P/L>	<L>	V	Y/G	

<B/L>      <V/R>

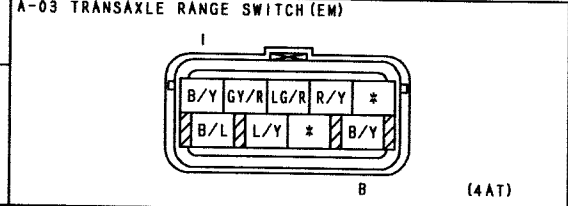
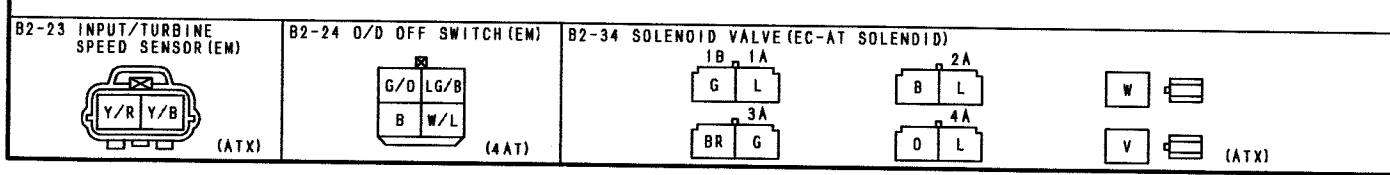
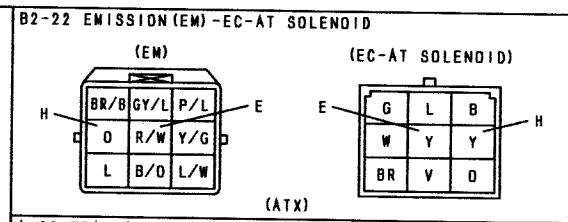

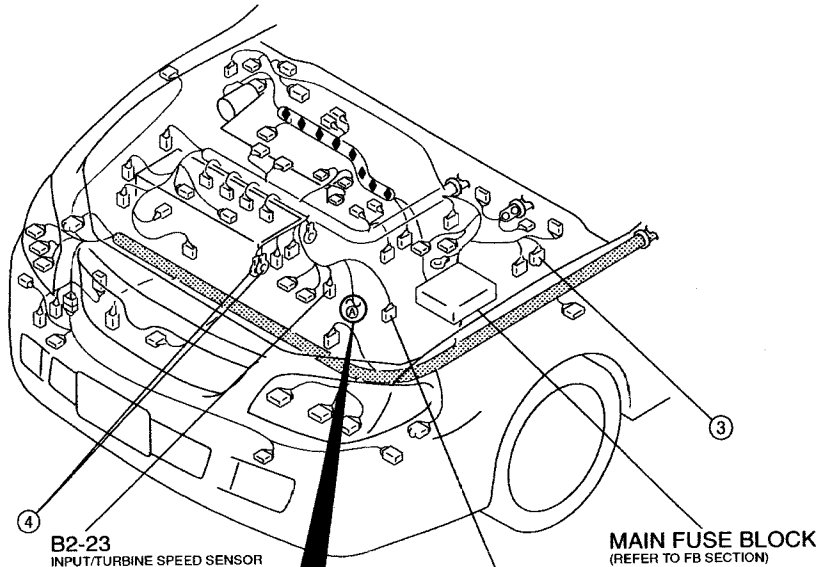

**INPUT/TURBINE SPEED SENSOR**  
The frequency from this sensor supplies the PCM with turbine shaft speed signal. This signal is used in determining line pressure and torque converter engagement schedules.

**TRANSAXLE RANGE SWITCH**  
Detects selector lever position.

**B2-22**  
(EM)-EC-AT SOLENOID

**B2-34**  
SOLENOID VALVE  
(INSIDE OF TRANSAXLE)

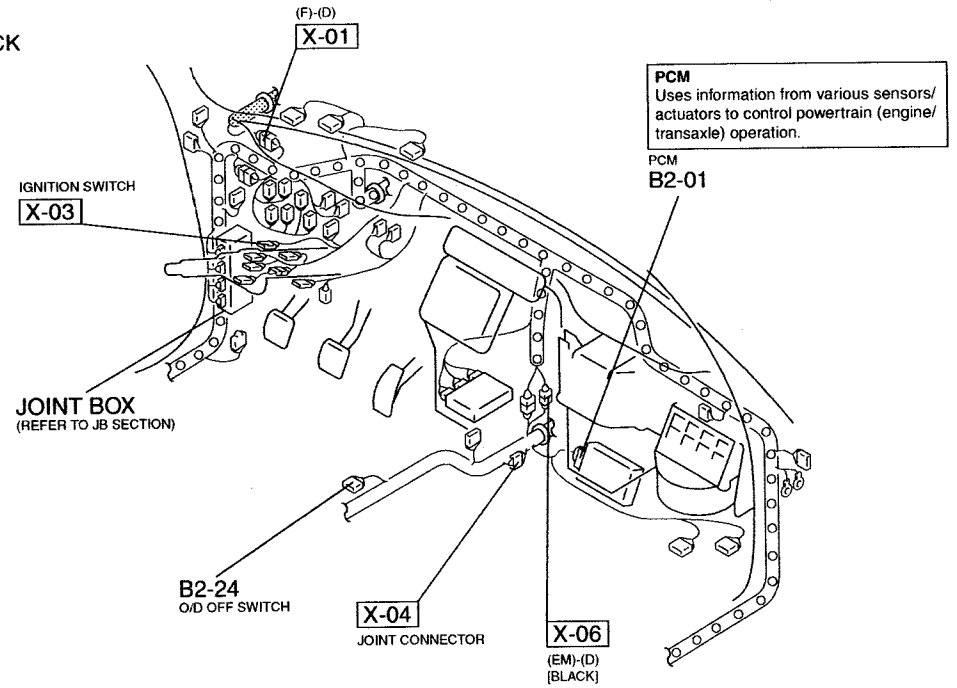

# EC-AT CONTROL SYSTEM (FS) / ENGINE CONTROL SYSTEM (FS)

< > ATX [ ] ATX:WITHOUT ABS  
 \* 4AT # SPORT AT  
 ( ) WITH VTCS SOLENOID VALVE

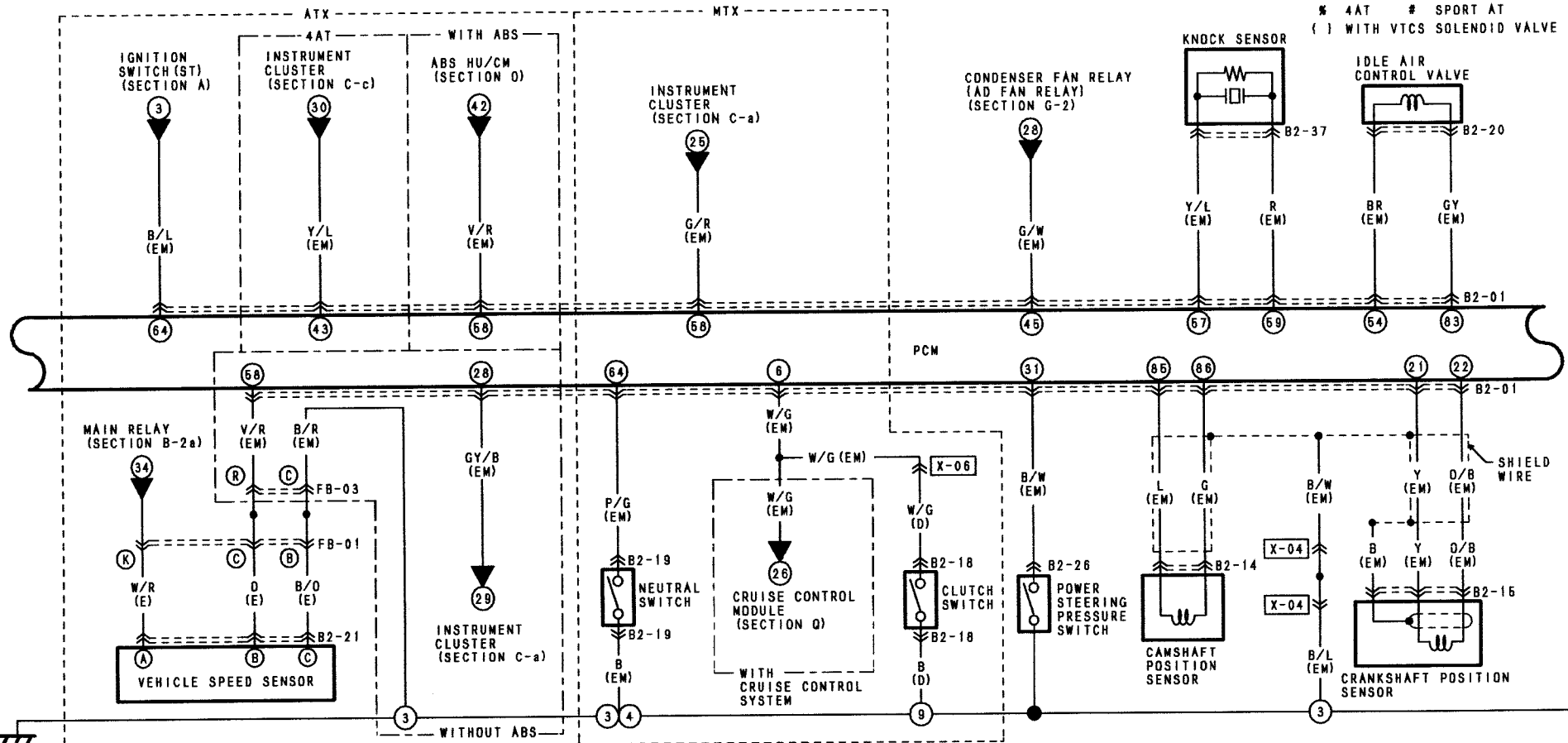

B2-01 PCM (EM)

26	25	24	23	22	21	20	19	18	17	16	15	14	13	12	11	10	9	8	7	6	5	4	3	2	1	*
R	*	B/W	<Y/B>	D/B	Y	#L/B	L/R	Y	#V	*	*	*	W/G	#R/B	*	*	#L/Y	#L/R	#L/R	*	<R/Y>	B/W	W/L	#G/O	[G/B]	<Y/G>
52	51	50	49	48	47	46	45	44	43	42	41	40	39	38	37	36	35	34	33	32	31	30	29	28	27	*
W	B/W	*	*	V/W	R/B	LG	G/W	<GY/L>	#Y/L	Y/B	G/B	*	L/W	V/Y	<R/W>	*	Y/L	R/L	*	<R/Y>	B/W	W/L	#G/O	[G/B]	<Y/G>	
78	77	76	75	74	73	72	71	70	69	68	67	66	65	64	63	62	61	60	59	58	57	56	55	54	53	*
#P	B/W	B/W	B/R	B/Y	[P]	V/G	W/B	*	*	BR/W	R/R	*	*	P/G	GY	R/B	*	P/L	R	G/R	Y/L	P	W/G	BR	LG/W	*
184	183	182	181	180	179	178	177	176	175	174	173	172	171	170	169	168	167	166	165	164	163	162	161	160	159	*
#L	B/R	<BR/B>	L/D	G/B	<L/W>	GY/R	W	L/B	B/LG	LG/R	G/R	G/Y	D	P/B	BR/Y	LG/B	*	G	L	<Y/R>	GY	<P/L>	<L>	V	Y/G	*

B2-14 CAMSHAFT POSITION SENSOR (EM) B2-15 CRANKSHAFT POSITION SENSOR (EM)

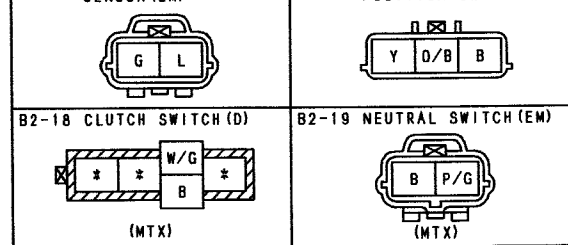

B2-18 CLUTCH SWITCH (D) B2-19 NEUTRAL SWITCH (EM)

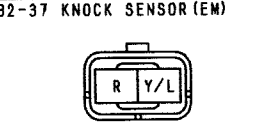
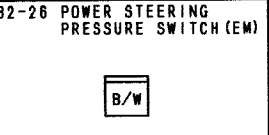
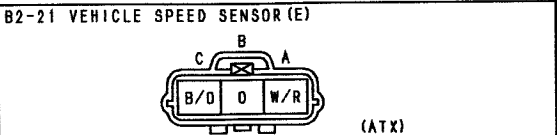
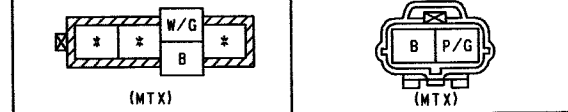

**CAMSHAFT POSITION SENSOR**  
Uses the magnetic pickup sensor.  
Detects camshaft position and  
sends signal to PCM.

[GRAY]  
CAMSHAFT POSITION SENSOR  
B2-14

[BLACK]  
KNOCK SENSOR  
B2-37

**KNOCK SENSOR**  
Detects knocking and sends signal to PCM.

[GRAY]  
IDLE AIR CONTROL VALVE  
B2-20

[GRAY]  
VEHICLE SPEED SENSOR  
B2-21

**VEHICLE SPEED SENSOR**  
Mounted on the transaxle or transmission, this  
sensor generates a signal that is proportional to  
vehicle speed and sends this signal to PCM.

B2-15  
CRANKSHAFT POSITION SENSOR  
[GRAY]

**CRANKSHAFT POSITION SENSOR**  
Uses the magnetic pickup sensor.  
Detects crankshaft position and sends  
signal to PCM.

B2-26  
POWER STEERING PRESSURE SWITCH

**POWER STEERING PRESSURE SWITCH**  
Power steering pressure switch signals PCM  
to increase idle speed to prevent engine from  
stalling.

B2-19  
NEUTRAL SWITCH  
[BLACK]

**NEUTRAL SWITCH**  
Opened when gear is in neutral position  
or clutch pedal is depressed. Sends  
signal to PCM, ABS control module.

**MAIN FUSE BLOCK**  
(REFER TO FB SECTION)

**CLUTCH SWITCH**  
Opened with clutch pedal depressed, Sends  
signal to PCM, ABS control module.

[BLACK]  
CLUTCH SWITCH  
B2-18

**PCM**  
Uses information from various sensors/  
actuators to control powertrain (engine/  
transaxle) operation.

PCM  
B2-01

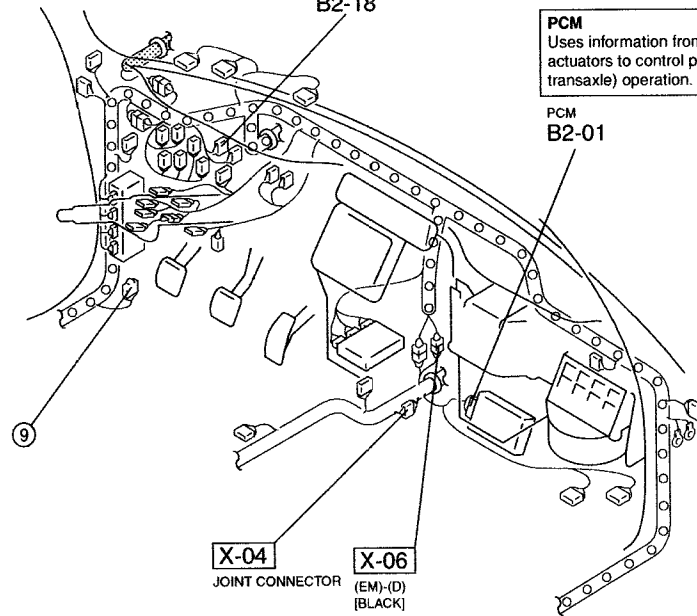

X-04  
JOINT CONNECTOR

X-06  
(EM)-(D)  
[BLACK]



EC-AT CONTROL SYSTEM (FS) / ENGINE CONTROL SYSTEM (FS)

26

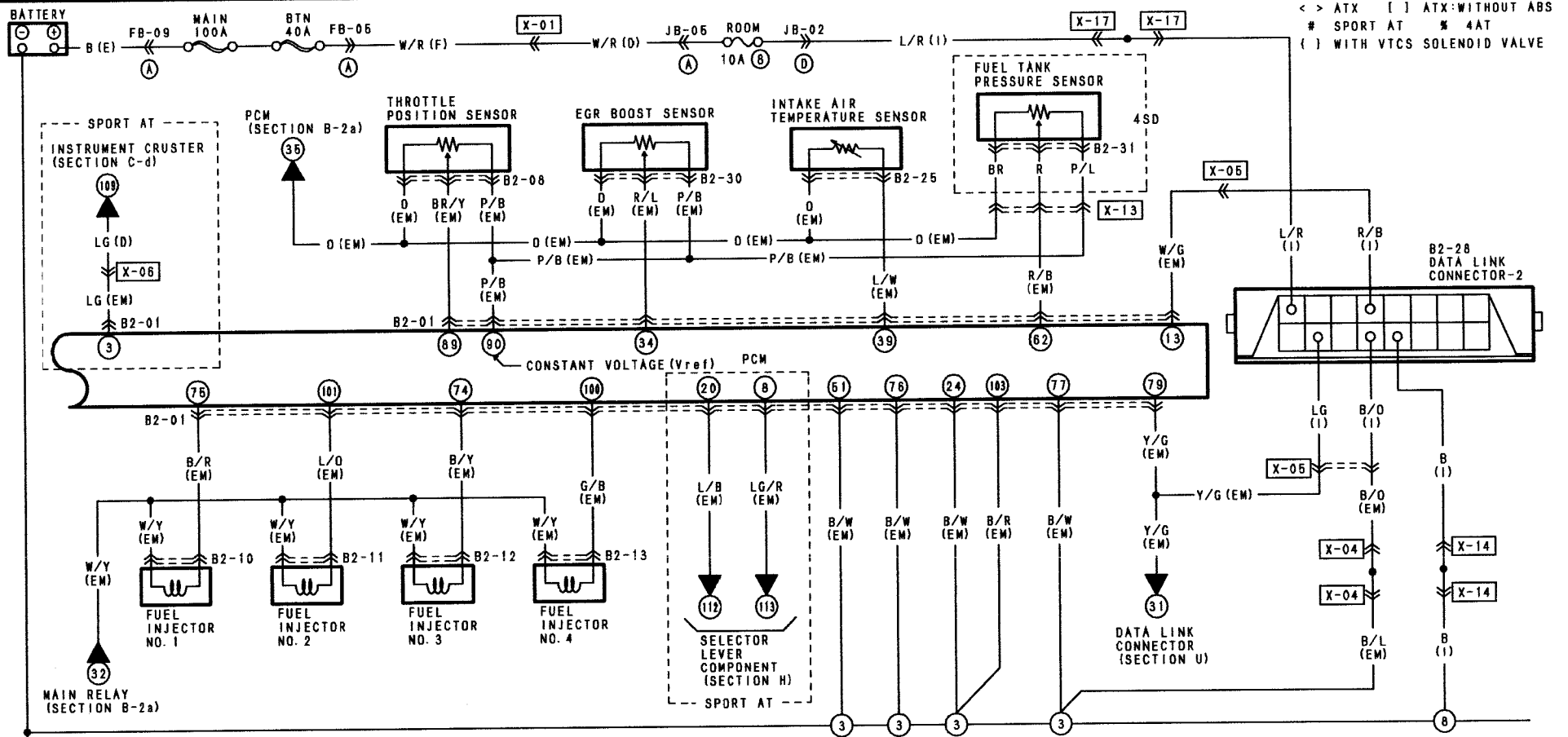

B2-01 PCM (EM)

26	25	24	23	22	21	20	19	18	17	16	15	14	13	12	11	10	9	8	7	6	5	4	3	2	1
R	*	B/W	Y/B	D/B	Y	#L/B	L/R	Y	#V	*	*	*	W/G	#R/B	*	*	#L/Y	#L/R	#L/R	W/G	BR/B	W/G	#L/R	G/B	D
52	51	50	49	48	47	46	45	44	43	42	41	40	39	38	37	36	35	34	33	32	31	30	29	28	27
W	B/W	*	*	V/W	R/B	LG	G/W	GY/L	Y/L	Y/B	G/B	*	L/W	V/W	Y/R	*	Y/L	R/L	*	R/Y	B/W	W/L	#G/D	#G/B	Y/G
78	77	76	75	74	73	72	71	70	69	68	67	66	65	64	63	62	61	60	59	58	57	56	55	54	53
#P	B/W	B/W	B/R	B/Y	{P}	V/G	W/B	*	BR/W	BR/R	*	*	*P/G	GY	R/B	*	P/L	R	G/R	Y/L	P	W/G	BR	LG	W
104	103	102	101	100	99	98	97	96	95	94	93	92	91	90	89	88	87	86	85	84	83	82	81	80	79
#L	B/R	BR/B	L/D	G/B	L/W	GY/R	W	L/B	B/LG	LG/R	G/R	G/Y	O	P/B	BR/Y	LG/B	*	G	L	Y/R	GY	P/L	L	L	V

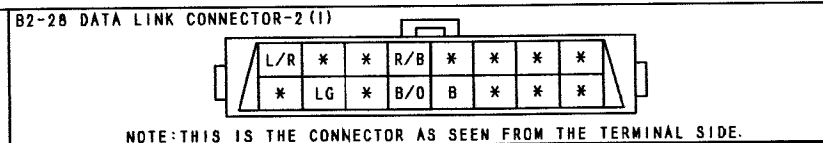
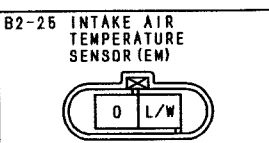
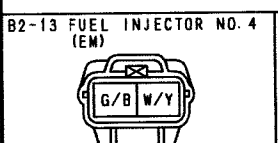

NOTE: THIS IS THE CONNECTOR AS SEEN FROM THE TERMINAL SIDE.

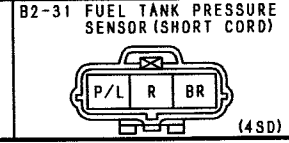
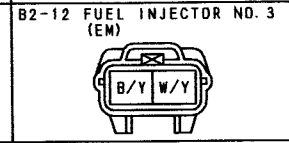
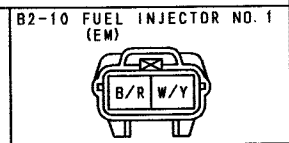
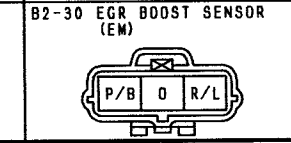
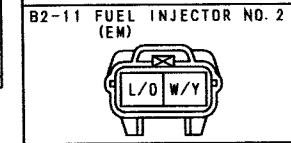
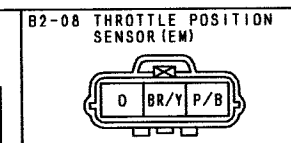

**FUEL INJECTOR**  
Controlled by PCM  
meters fuel to engine.

[GRAY]  
FUEL INJECTOR NO.1  
B2-10

[GRAY]  
FUEL INJECTOR NO.2  
B2-11

[BLACK]  
EGR BOOST SENSOR  
B2-30

[GRAY]  
FUEL INJECTOR NO.3  
B2-12

[GRAY]  
FUEL INJECTOR NO.4  
B2-13

**THROTTLE POSITION SENSOR**  
Detects throttle opening angle and  
sends signal to PCM.

B2-08  
THROTTLE POSITION SENSOR  
[GRAY]

**INTAKE AIR TEMPERATURE SENSOR**  
Detects intake air temperature and sends  
signal to PCM.

B2-25  
INTAKE AIR TEMPERATURE SENSOR

**MAIN FUSE BLOCK**  
(REFER TO FB SECTION)

DATA LINK CONNECTOR-2  
B2-28

**JOINT BOX**  
(REFER TO JB SECTION)

**PCM**  
Uses information from various sensors/  
actuators to control powertrain (engine/  
transaxle) operation.

PCM  
B2-01

X-05  
(EM)-(I)

X-04

X-06  
(EM)-(D)  
[BLACK]

JOINT CONNECTOR

X-14  
JOINT CONNECTOR

X-17  
JOINT CONNECTOR

X-05  
(EM)-(I)

(EM)-SHORT CORD  
X-13

**FUEL TANK PRESSURE SENSOR**  
Detects fuel tank pressure and sends  
signal to PCM. This signal is used for  
evaporative system monitoring.

B2-31  
FUEL TANK PRESSURE SENSOR  
[BLACK]

**NOTE :** 5HB connector locations are almost the same  
as the 4SD connector locations.

# INSTRUMENT CLUSTER

28

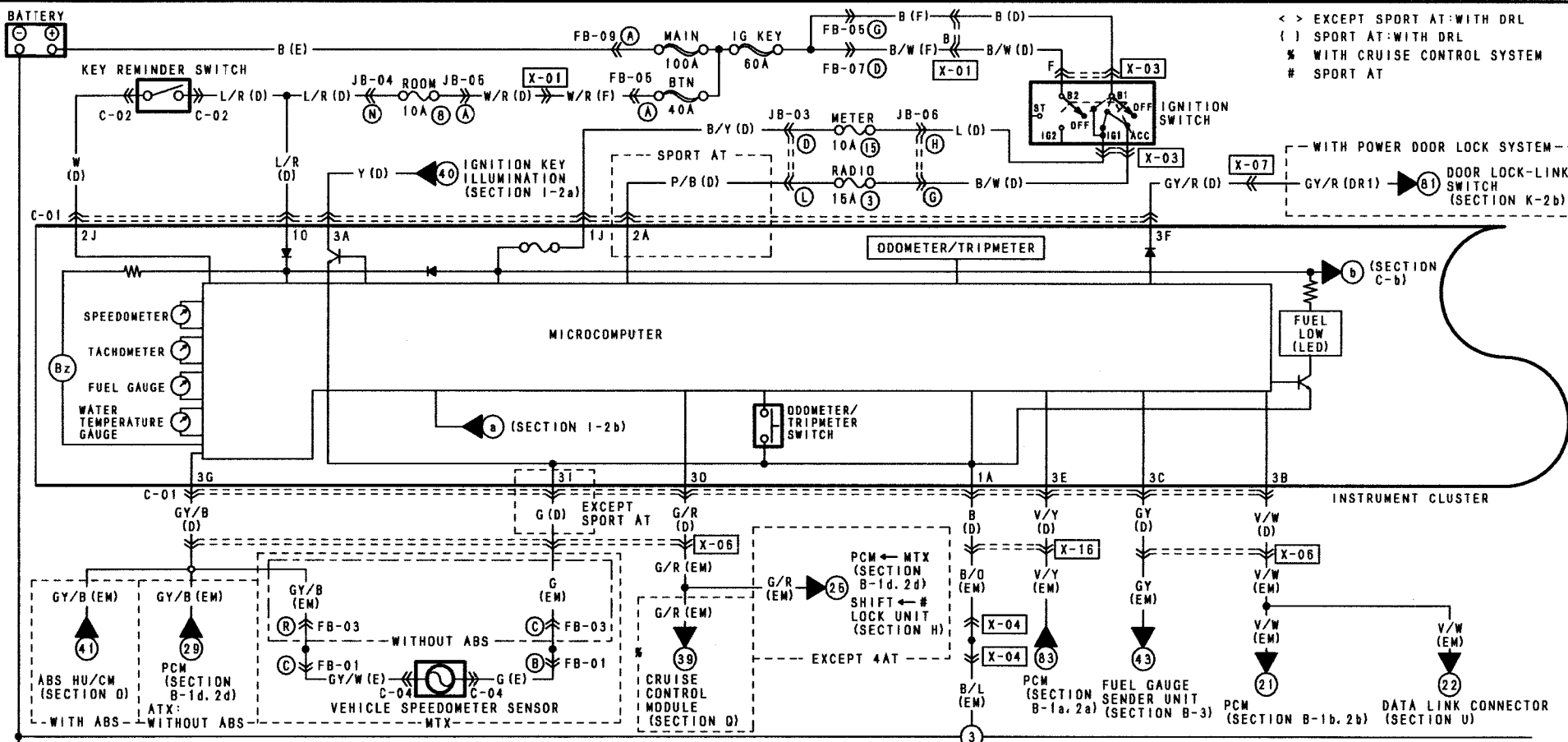

- < > EXCEPT SPORT AT: WITH DRL
- ( ) SPORT AT: WITH DRL
- \* WITH CRUISE CONTROL SYSTEM
- # SPORT AT

WITH POWER DOOR LOCK SYSTEM  
DOOR LOCK-LINK SWITCH (SECTION K-2-b)

C-01 INSTRUMENT CLUSTER (D)

1Q	1D	1M	1K	1I	1G	1E	1C	1A	2D	2M	2K	2I	2G	2E	2C	2A
Y	L/R	W/L	Y/B	B/L	BR/B	LG/B	*	B	*R/Y	*W/G	*G	*	*	*	*	*P/B
BR/R	L	L/D	LG/R	B/Y	Y/R	R	B	G/W	*R	*P	*V	W	Y/L	*(BR/W)	R/G	R/L
1R	1P	1N	1L	1J	1H	1F	1D	1B	2P	2N	2L	2J	2H	2F	2D	2B

3S	3Q	3M	3K	3I	3G	3E	3C	3A		
*	*	G/R	*	R/G	G	GY/B	V/Y	GY	Y	
*	*	#G/Y	#LG	*	G/B	O	#L	GY/R	*	V/W
3T	3R	3P	3N	3L	3J	3H	3F	3D	3B	

C-02 KEY REMINDER SWITCH (D)



C-04 VEHICLE SPEEDOMETER SENSOR (E)



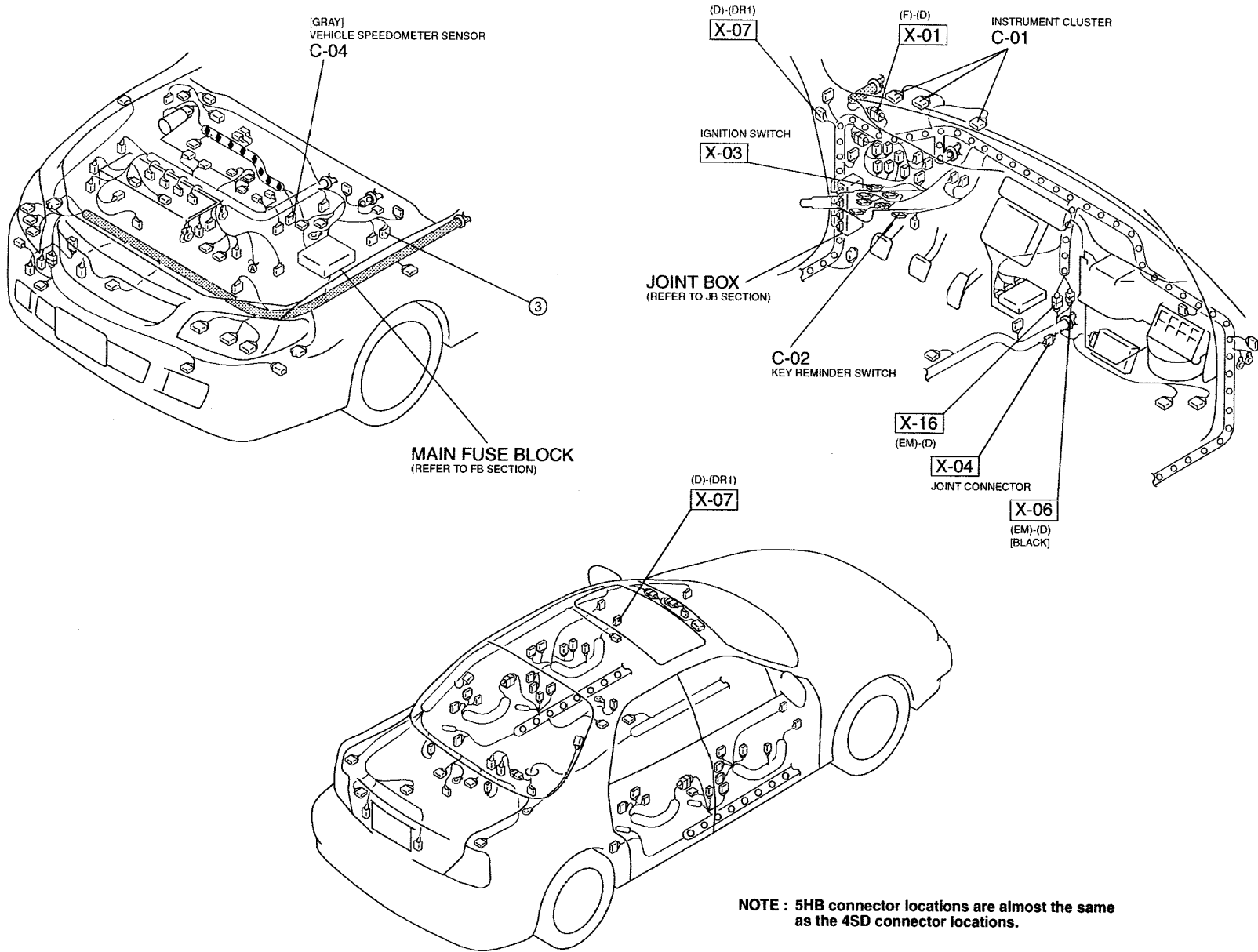

HARNESS SYMBOL :  (F)  (E)  (D)  (R)

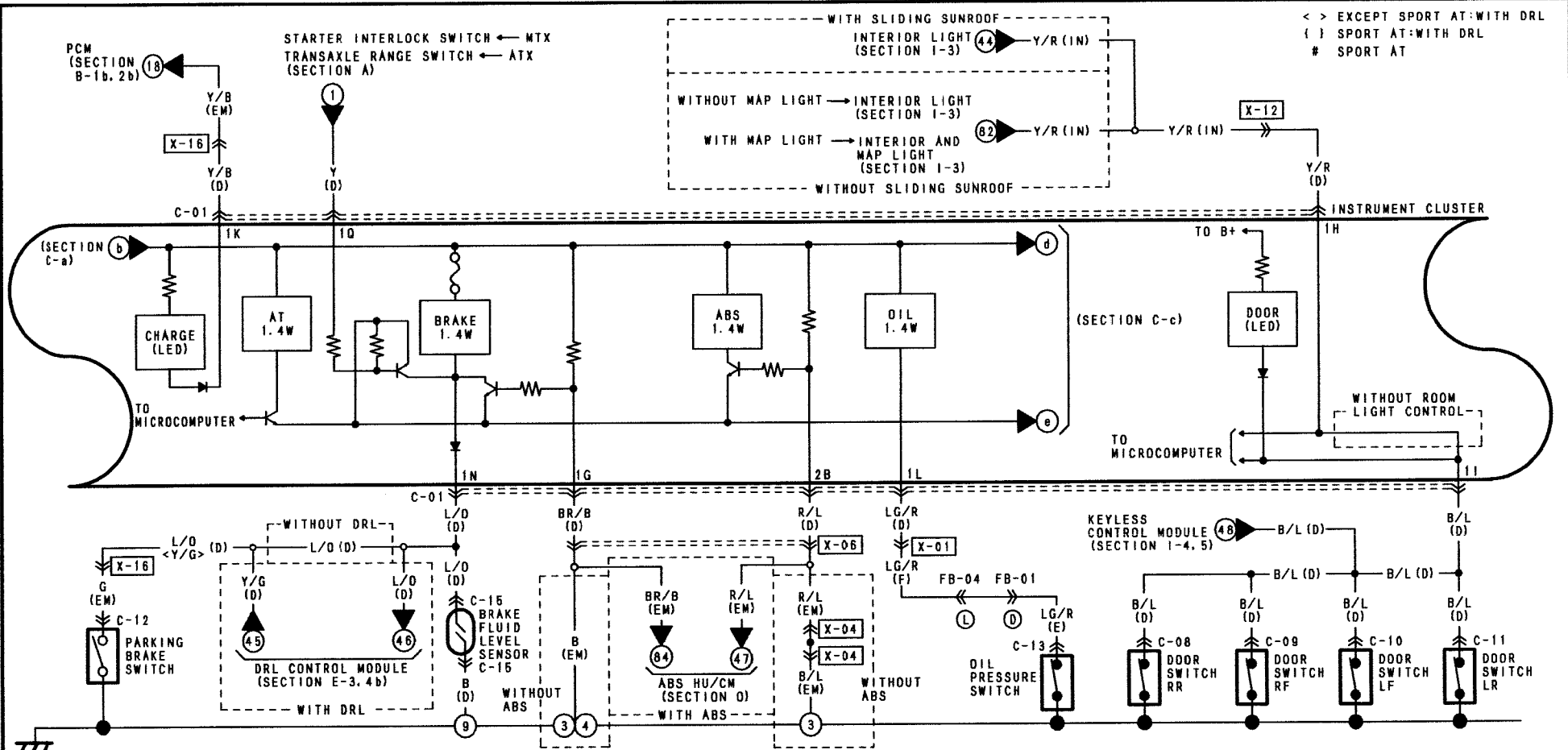

INSTRUMENT CLUSTER

30



<p>C-01 INSTRUMENT CLUSTER (D)</p> <table border="1"> <tr> <td>1Q</td><td>1Q</td><td>1M</td><td>1K</td><td>1I</td><td>1G</td><td>1E</td><td>1C</td><td>1A</td> </tr> <tr> <td>Y</td><td>L/R</td><td>W/L</td><td>Y/B</td><td>B/L</td><td>BR/B</td><td>LG/B</td><td>*</td><td>B</td> </tr> <tr> <td>BR/R</td><td>L</td><td>L/D</td><td>LG/R</td><td>B/Y</td><td>Y/R</td><td>R</td><td>B</td><td>G/W</td> </tr> <tr> <td>1R</td><td>1P</td><td>1N</td><td>1L</td><td>1J</td><td>1H</td><td>1F</td><td>1D</td><td>1B</td> </tr> </table> <table border="1"> <tr> <td>20</td><td>2M</td><td>2K</td><td>2I</td><td>2G</td><td>2E</td><td>2C</td><td>2A</td> </tr> <tr> <td>* BR/Y</td><td>* W/G</td><td>* G</td><td>* *</td><td>* *</td><td>* *</td><td>* *</td><td>* #P/B</td> </tr> <tr> <td>* #Y/R</td><td>* #P</td><td>* #V</td><td>W</td><td>Y/L</td><td>* #(BR/W)</td><td>R/G</td><td>R/L</td> </tr> <tr> <td>2P</td><td>2N</td><td>2L</td><td>2J</td><td>2H</td><td>2F</td><td>2D</td><td>2B</td> </tr> </table>	1Q	1Q	1M	1K	1I	1G	1E	1C	1A	Y	L/R	W/L	Y/B	B/L	BR/B	LG/B	*	B	BR/R	L	L/D	LG/R	B/Y	Y/R	R	B	G/W	1R	1P	1N	1L	1J	1H	1F	1D	1B	20	2M	2K	2I	2G	2E	2C	2A	* BR/Y	* W/G	* G	* *	* *	* *	* *	* #P/B	* #Y/R	* #P	* #V	W	Y/L	* #(BR/W)	R/G	R/L	2P	2N	2L	2J	2H	2F	2D	2B	<p>C-08 DOOR SWITCH RR (D)</p>	<p>C-09 DOOR SWITCH RF (D)</p>	<p>C-10 DOOR SWITCH LF (D)</p>	<p>C-11 DOOR SWITCH LR (D)</p>	<p>C-12 PARKING BRAKE SWITCH (EM)</p>
1Q	1Q	1M	1K	1I	1G	1E	1C	1A																																																																	
Y	L/R	W/L	Y/B	B/L	BR/B	LG/B	*	B																																																																	
BR/R	L	L/D	LG/R	B/Y	Y/R	R	B	G/W																																																																	
1R	1P	1N	1L	1J	1H	1F	1D	1B																																																																	
20	2M	2K	2I	2G	2E	2C	2A																																																																		
* BR/Y	* W/G	* G	* *	* *	* *	* *	* #P/B																																																																		
* #Y/R	* #P	* #V	W	Y/L	* #(BR/W)	R/G	R/L																																																																		
2P	2N	2L	2J	2H	2F	2D	2B																																																																		
	<p>C-13 OIL PRESSURE SWITCH (E)</p>	<p>C-15 BRAKE FLUID LEVEL SENSOR (D)</p>																																																																							

< > EXCEPT SPORT AT: WITH DRL  
 ( ) SPORT AT: WITH DRL  
 # SPORT AT

**OIL PRESSURE SWITCH**  
Closes when oil pressure is low.

OIL PRESSURE SWITCH  
C-13

[BLACK]  
BRAKE FLUID LEVEL SENSOR  
C-15

**MAIN FUSE BLOCK**  
(REFER TO FB SECTION)

[BLACK]  
DOOR SWITCH LF  
C-10

[BLACK]  
DOOR SWITCH LR  
C-11

[BLACK]  
(D)-(IN)  
X-12

C-09  
DOOR SWITCH RF  
[BLACK]

C-12  
PARKING BRAKE SWITCH

C-08  
DOOR SWITCH RR  
[BLACK]

(F)-(D)  
X-01

INSTRUMENT CLUSTER  
C-01

[BLACK]  
(EM)-(D)  
X-06

X-16  
(EM)-(D)

X-04  
JOINT CONNECTOR

**NOTE : 5HB connector locations are almost the same as the 4SD connector locations.**

INSTRUMENT CLUSTER

32

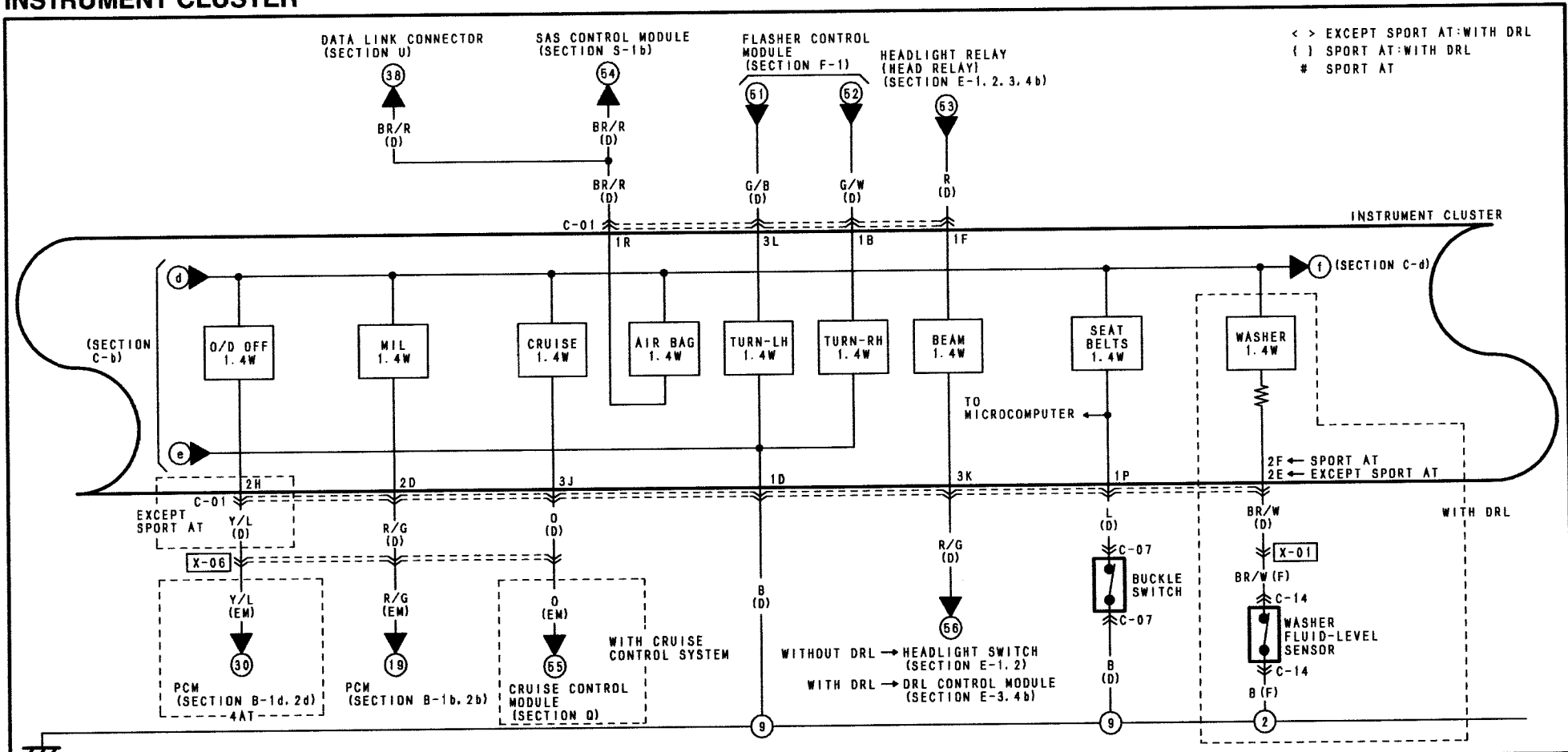

< > EXCEPT SPORT AT:WITH DRL  
 ( ) SPORT AT:WITH DRL  
 # SPORT AT

C-01 INSTRUMENT CLUSTER (D)

1Q	10	1M	1K	1I	1G	1E	1C	1A		
Y	L/R	W/L	Y/B	B/L	BR/B	LG/B	*	B		
BR/R	L	L/D	LG/R	B/Y	Y/R	R	B	G/W		
1R	1P	1N	1L	1J	1H	1F	1D	1B		

2D	2M	2K	2I	2G	2E	2C	2A		
*#R/Y	*#W/G	*#G	*	*	*	*	*#P/B		
*#Y/R	*#P	*#V	W	Y/L	BR/W	R/G	R/L		
2P	2N	2L	2J	2H	2F	2D	2B		

  

3S	3Q	3M	3K	3I	3G	3E	3C	3A		
*	*	G/R	*	R/G	G	GY/B	V/Y	GY	Y	
*	*#G/Y	*#LG	*	G/B	O	*#L	GY/R	*	V/W	
3T	3R	3P	3N	3L	3J	3H	3F	3D	3B	

C-07 BUCKLE SWITCH (D)



C-14 WASHER FLUID-LEVEL SENSOR (F)

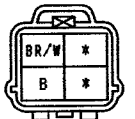

(WITH DRL)

HARNES SYMBOL :  (F)  (E)  (D)  (R)

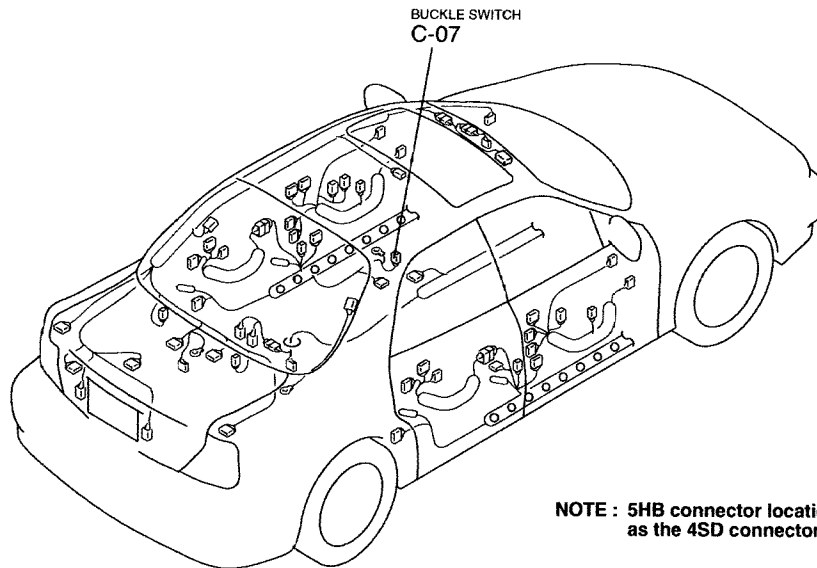
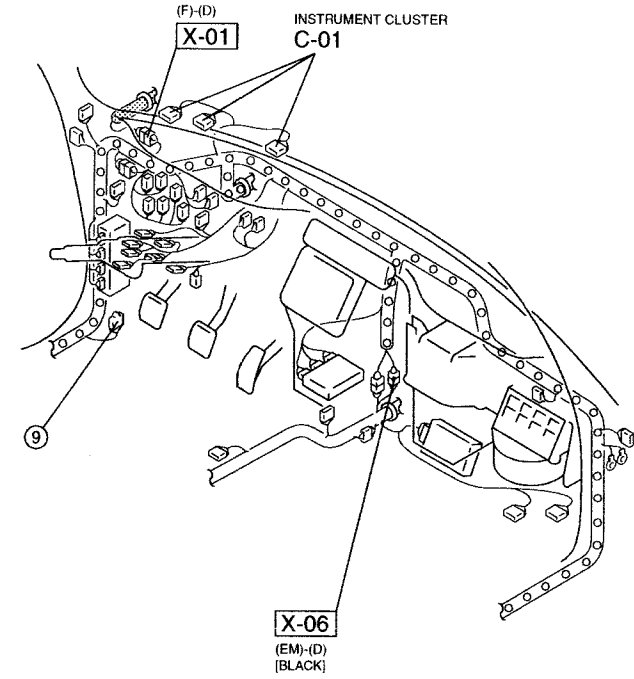
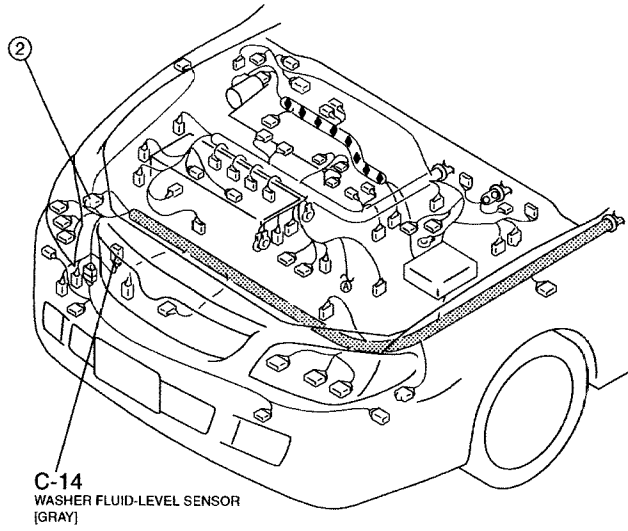

NOTE : 5HB connector locations are almost the same as the 4SD connector locations.



INSTRUMENT CLUSTER

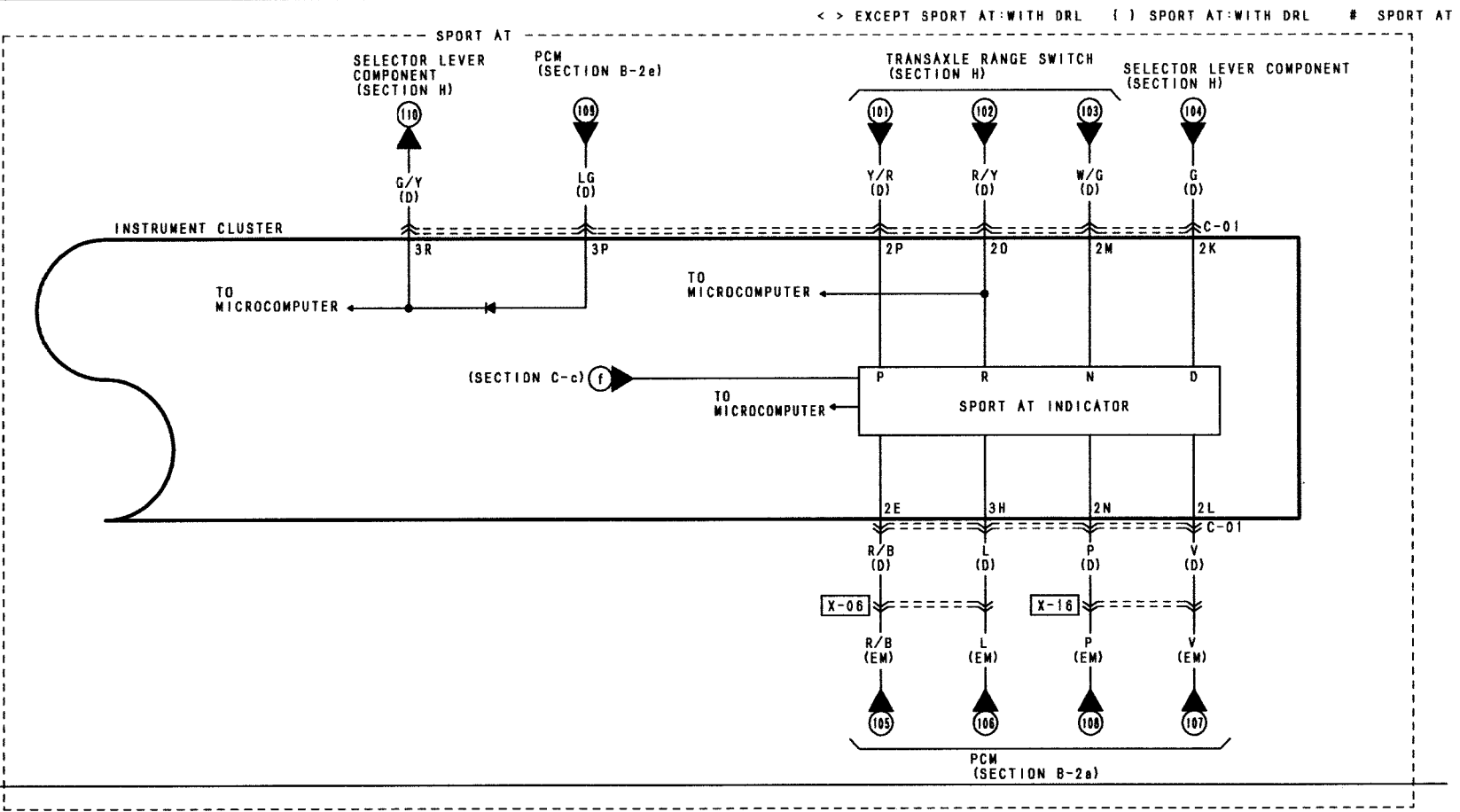

34

777

C-01 INSTRUMENT CLUSTER (D)

2D	2M	2K	2I	2G	2E	2C	2A
*#R/Y	*#W/G	*#G	*	*	*	*	*#P/B
*#Y/R	*#P	*#V	W	Y/L	*	R/G	R/L
2P	2N	2L	2J	2H	2F	2D	2B

3S	3D	3D	3M	3K	3I	3G	3E	3C	3A
*	*	G/R	*	R/G	G	GY/B	V/Y	GY	Y
*	*#G/Y	*#LG	*	G/B	O	*#L	GY/R	*	V/W
3T	3R	3P	3N	3L	3J	3H	3F	3D	3B

HARNESS SYMBOL :  (F)  (E)  (D)  (R)

35

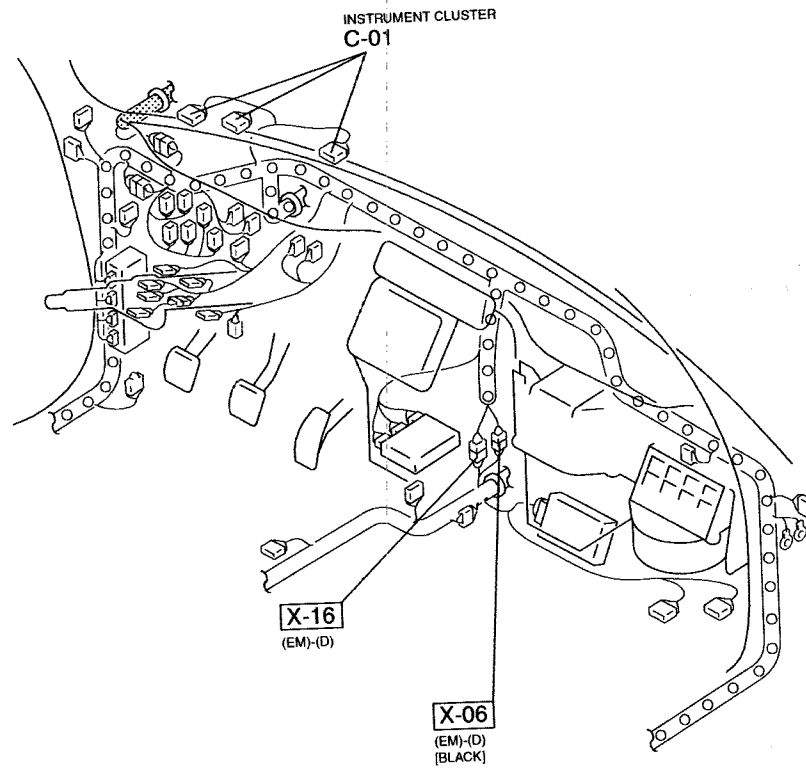

C-d

FRONT FOG LIGHT (4SD)

36

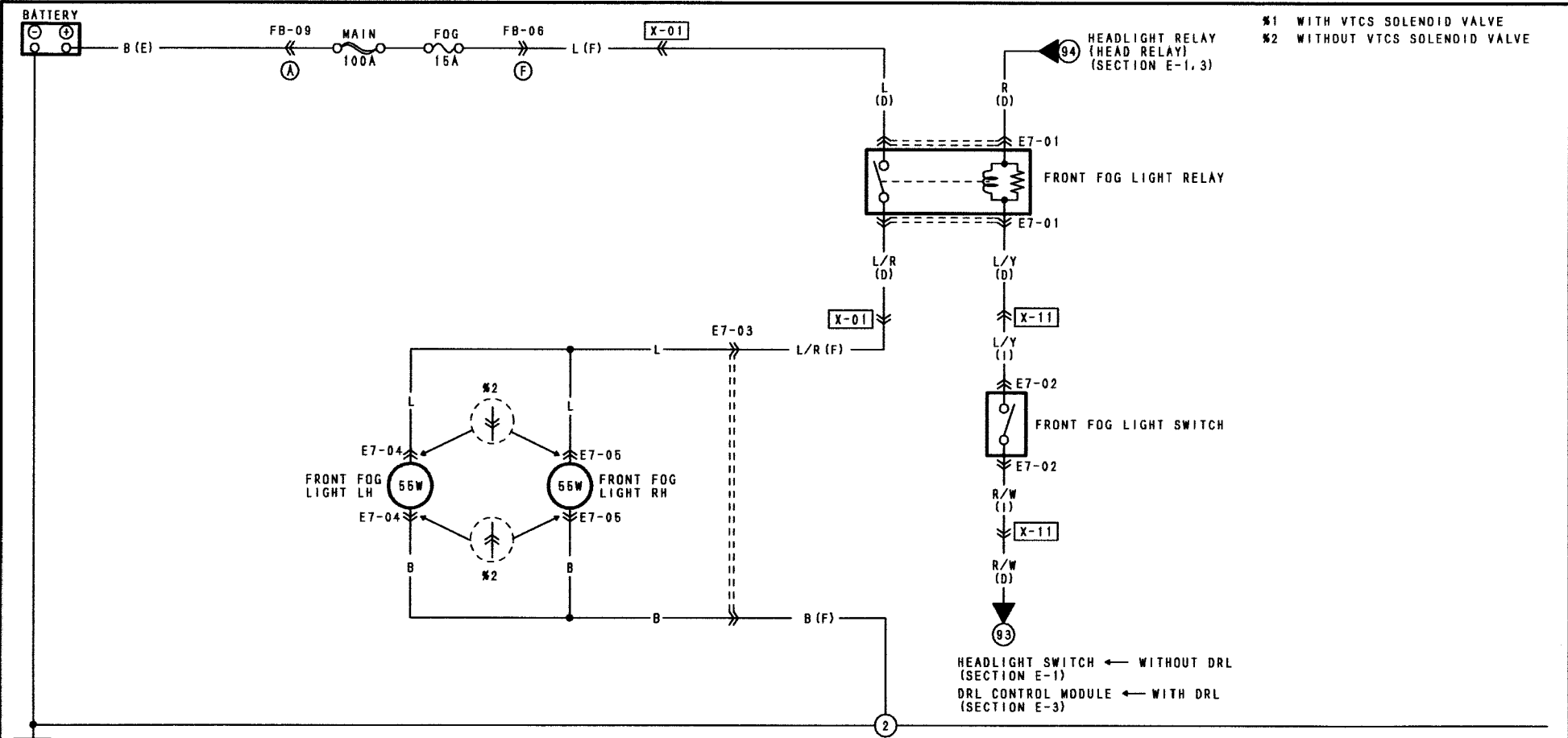

<p>E7-01 FRONT FOG LIGHT RELAY (D)</p>	<p>E7-02 FRONT FOG LIGHT SWITCH (1)</p>	<p>E7-03 FRONT (F) -SHORT CORD</p>	<p>E7-04 FRONT FOG LIGHT LH (SHORT CORD)</p> <p>(#1)      (#2)</p> <p>E7-05 FRONT FOG LIGHT RH (SHORT CORD)</p> <p>(#1)      (#2)</p>

HARNESS SYMBOL :  (F)  (E)  (D)  (R)

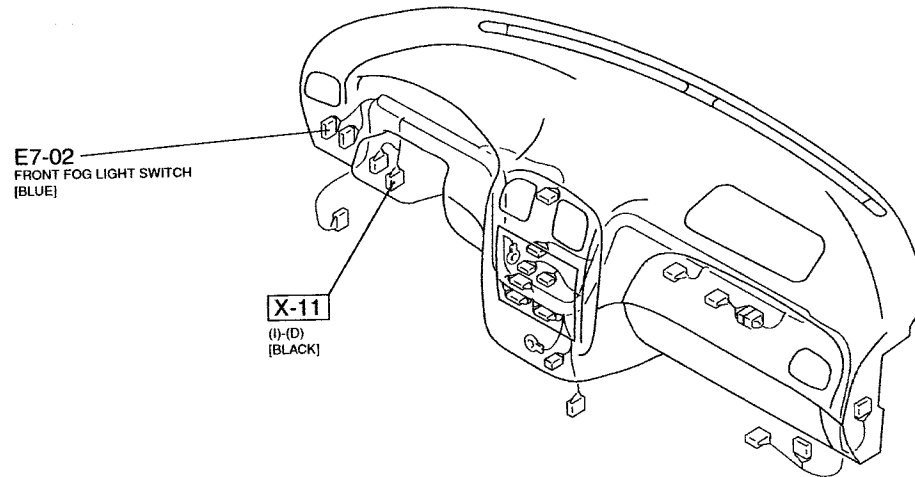
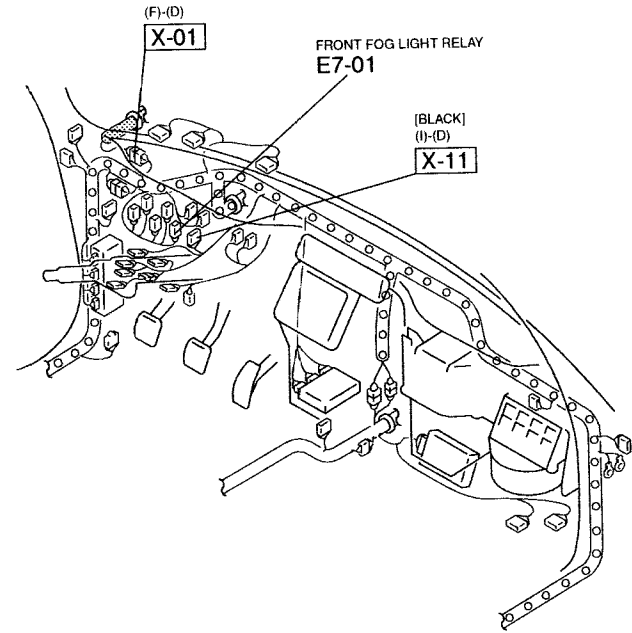
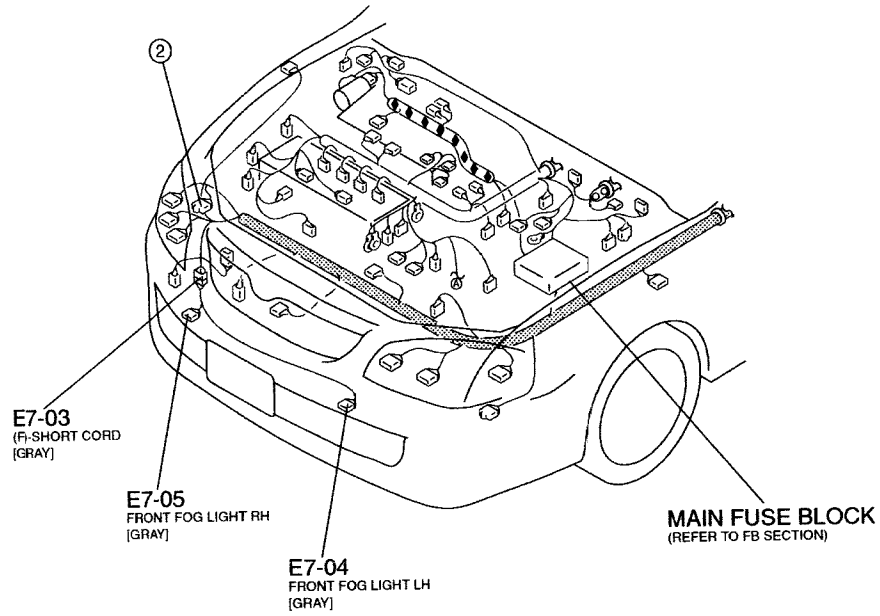

# TURN AND HAZARD WARNING LIGHT

F-1

38

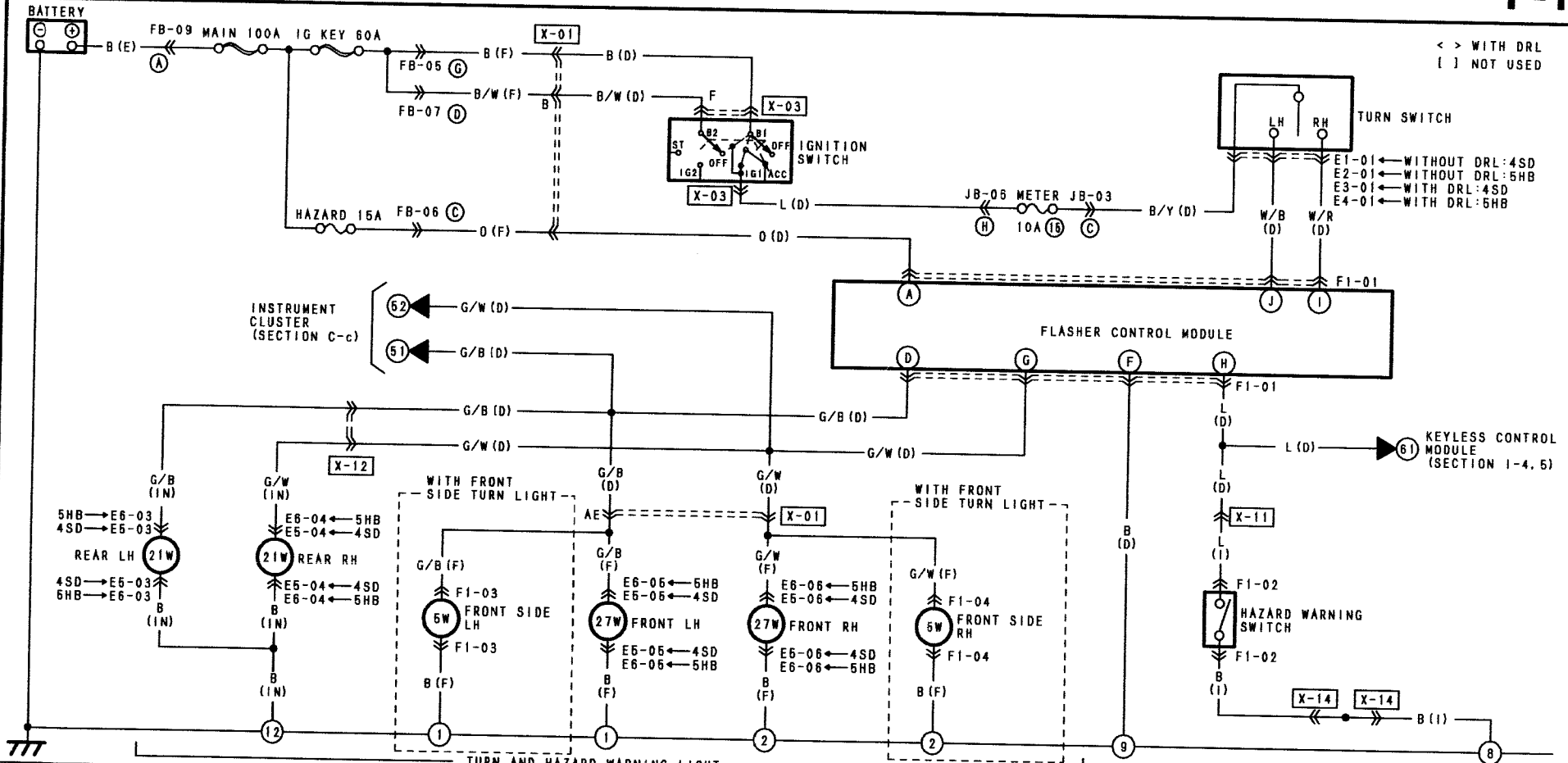

< > WITH DRL  
[ ] NOT USED

<p>F1-01 FLASHER CONTROL MODULE (D)</p> <table border="1"> <tr><td>I</td><td>G</td><td></td><td>A</td></tr> <tr><td>W/R</td><td>G/W</td><td>⊗</td><td>O</td></tr> <tr><td>W/B</td><td>L</td><td>B</td><td>G/B</td></tr> <tr><td>J</td><td>H</td><td>F</td><td>D</td></tr> </table>	I	G		A	W/R	G/W	⊗	O	W/B	L	B	G/B	J	H	F	D	<p>F1-02 HAZARD WARNING SWITCH (I)</p> <table border="1"> <tr><td>*</td><td>*</td><td>⊗</td><td>*</td><td>*</td></tr> <tr><td>*</td><td>W/L</td><td>LG/B</td><td>*</td><td>L</td></tr> <tr><td></td><td></td><td></td><td></td><td>B</td></tr> </table>	*	*	⊗	*	*	*	W/L	LG/B	*	L					B	<p>F1-03 TURN AND HAZARD WARNING LIGHT FRONT SIDE LH (F)</p> <p>(WITH FRONT SIDE TURN LIGHT)</p>	<p>F1-04 TURN AND HAZARD WARNING LIGHT FRONT SIDE RH (F)</p> <p>(WITH FRONT SIDE TURN LIGHT)</p>	<p>E1-01 TURN SWITCH (D) E2-01 WITHOUT DRL: 4SD E3-01 WITHOUT DRL: 5HB E4-01 WITH DRL: 4SD E5-01 WITH DRL: 5HB</p> <table border="1"> <tr><td>Q</td><td>R/Y</td><td>R/G</td><td>*</td><td>*</td><td>*</td><td>⊗</td><td>W/R</td><td>B/Y</td><td>W/B</td></tr> <tr><td></td><td>&lt;LG&gt;</td><td>&lt;Y&gt;</td><td></td><td></td><td></td><td></td><td></td><td></td><td></td></tr> <tr><td></td><td>R/W</td><td>&lt;X&gt;</td><td>*</td><td>BR</td><td>R/Y</td><td>&lt;W&gt;</td><td>*</td><td>*</td><td>*</td></tr> <tr><td></td><td></td><td></td><td>B</td><td></td><td></td><td></td><td></td><td></td><td></td></tr> </table>	Q	R/Y	R/G	*	*	*	⊗	W/R	B/Y	W/B		<LG>	<Y>									R/W	<X>	*	BR	R/Y	<W>	*	*	*				B						
I	G		A																																																																								
W/R	G/W	⊗	O																																																																								
W/B	L	B	G/B																																																																								
J	H	F	D																																																																								
*	*	⊗	*	*																																																																							
*	W/L	LG/B	*	L																																																																							
				B																																																																							
Q	R/Y	R/G	*	*	*	⊗	W/R	B/Y	W/B																																																																		
	<LG>	<Y>																																																																									
	R/W	<X>	*	BR	R/Y	<W>	*	*	*																																																																		
			B																																																																								
<p>E5-03 TURN AND HAZARD WARNING LIGHT REAR LH (IN) E6-03 4SD E6-03 5HB</p>	<p>E5-04 TURN AND HAZARD WARNING LIGHT REAR RH (IN) E6-04 4SD E6-04 5HB</p>	<p>E5-05 TURN AND HAZARD WARNING LIGHT FRONT LH (F) E6-05 4SD E6-05 5HB</p>	<p>E5-06 TURN AND HAZARD WARNING LIGHT FRONT RH (F) E6-06 4SD E6-06 5HB</p>																																																																								

HARNESS SYMBOL :  (F)  (E)  (D)  (R)

TURN AND HAZARD WARNING LIGHT  
FRONT SIDE RH  
F1-04

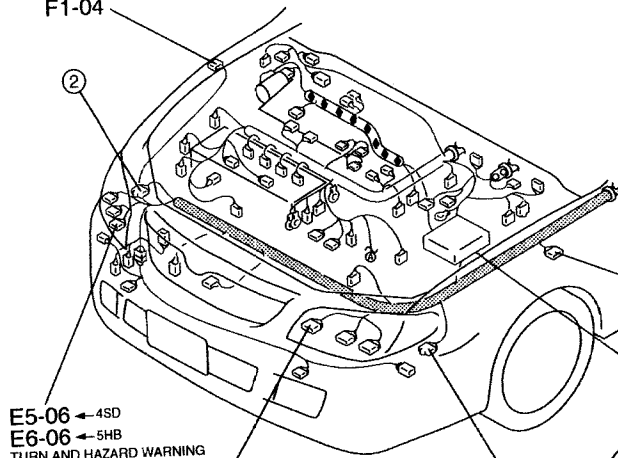

F1-03  
TURN AND HAZARD WARNING LIGHT  
FRONT SIDE LH

MAIN FUSE BLOCK  
(REFER TO FB SECTION)

E5-05 ← 4SD  
E6-05 ← 5HB  
TURN AND HAZARD WARNING LIGHT FRONT LH [GRAY]

JOINT BOX  
(REFER TO JB SECTION)

HAZARD WARNING SWITCH  
F1-02

E1-01 ← WITHOUT DRL : 4SD  
E2-01 ← WITHOUT DRL : 5HB  
E3-01 ← WITH DRL : 4SD  
E4-01 ← WITH DRL : 5HB  
TURN SWITCH

(F)-(D)  
X-01  
FLASHER CONTROL MODULE  
F1-01

**FLASHER CONTROL MODULE**  
With the turn signal switch in the left or right position or hazard switch on, the flasher module directs voltage to the appropriate lamps and indicators.

[BLACK]  
(D)-(IN)  
X-12

[BLACK]  
(I)-(D)  
X-11

IGNITION SWITCH  
X-03

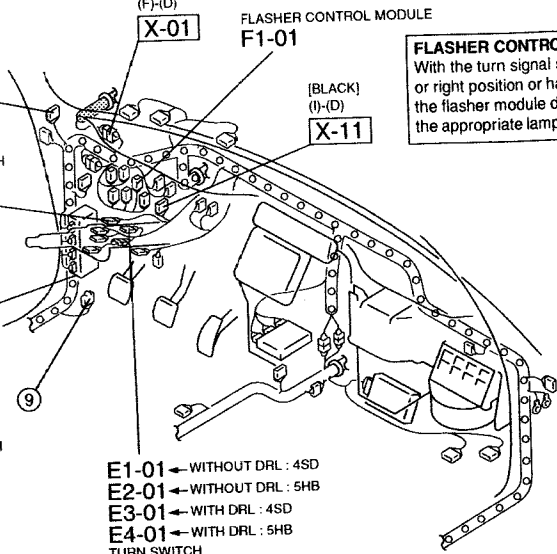

39

X-11  
(I)-(D)  
[BLACK]

X-14  
JOINT CONNECTOR

[BLACK]  
(D)-(IN)  
X-12

[BLACK]  
TURN AND HAZARD WARNING LIGHT REAR LH  
E5-03

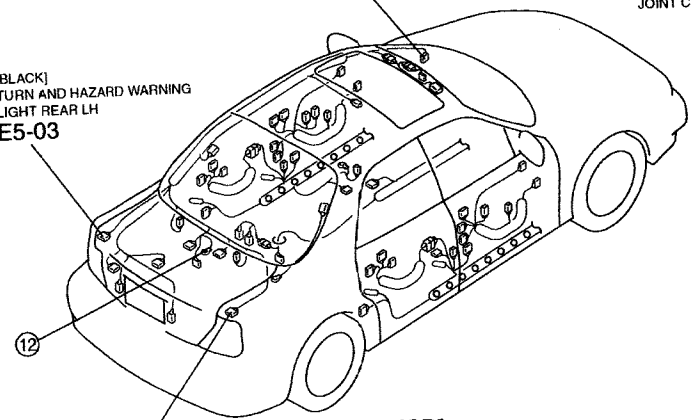

E5-04  
TURN AND HAZARD WARNING LIGHT REAR RH [BLACK]

[4SD]

[BLACK]  
(D)-(IN)  
X-12

E6-03  
TURN AND HAZARD WARNING LIGHT REAR LH [BLACK]

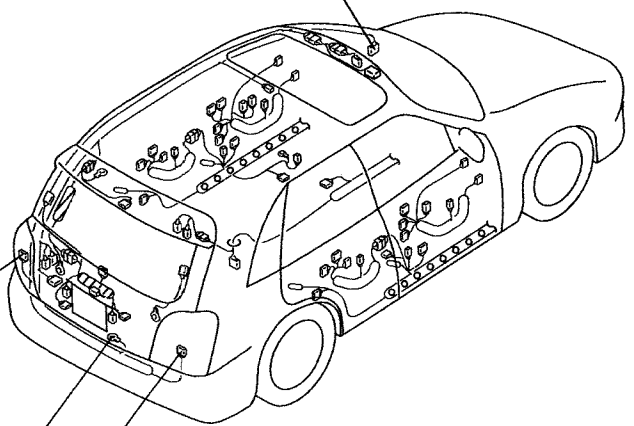

E6-04  
TURN AND HAZARD WARNING LIGHT REAR RH [BLACK]

[5HB]

BACK-UP LIGHT

[ ] NOT USED

40

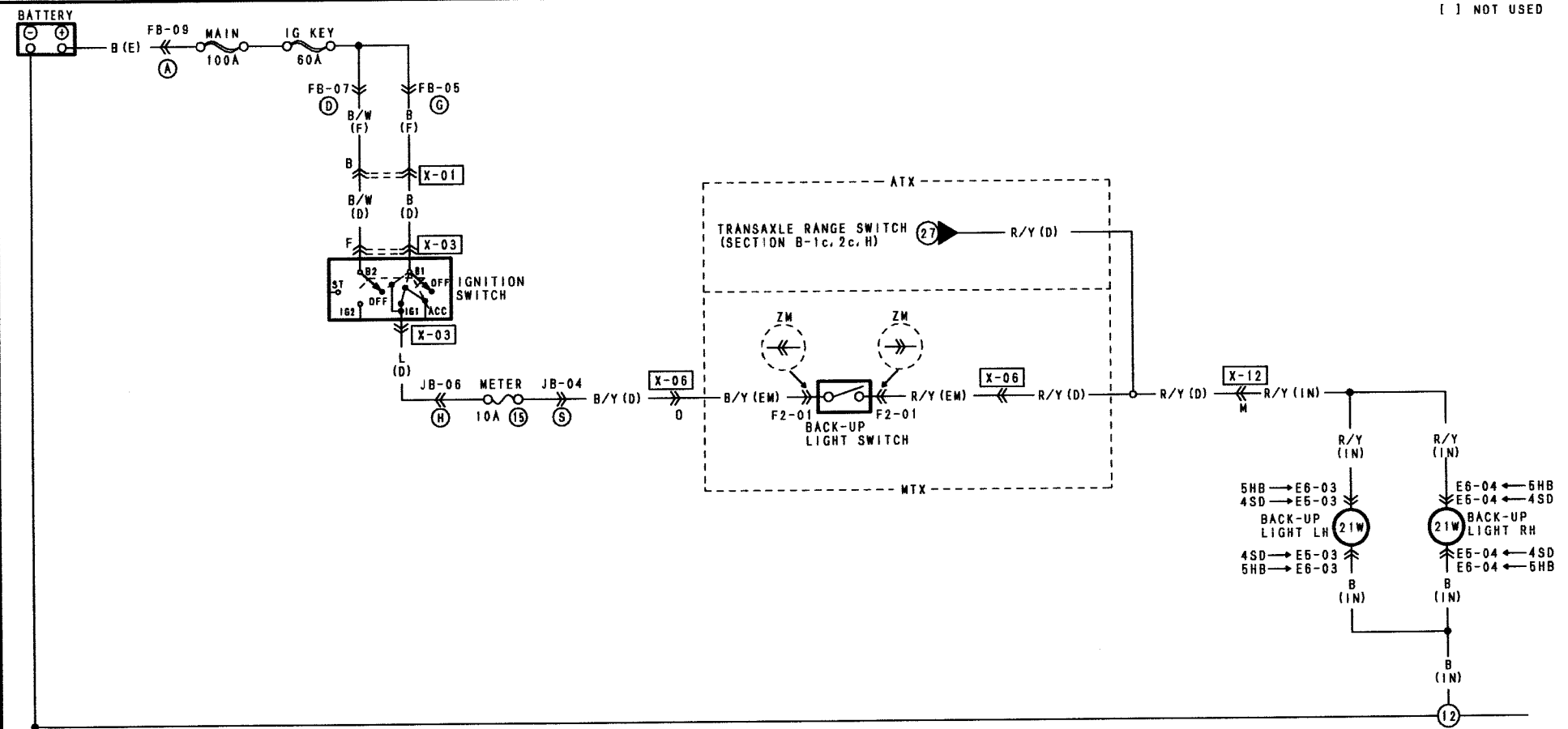

F2-01 BACK-UP LIGHT SWITCH (EM)



(ZM:MTX)

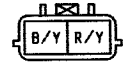

(FS:MTX)

E6-03 BACK-UP LIGHT LH (IN)  
E6-03

4SD  
5HB

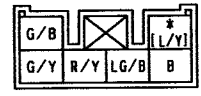

E5-04 BACK-UP LIGHT RH (IN)  
E6-04

4SD  
5HB

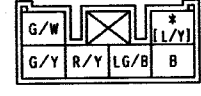

HARNESS SYMBOL :  (F)  (E)  (D)  (R)

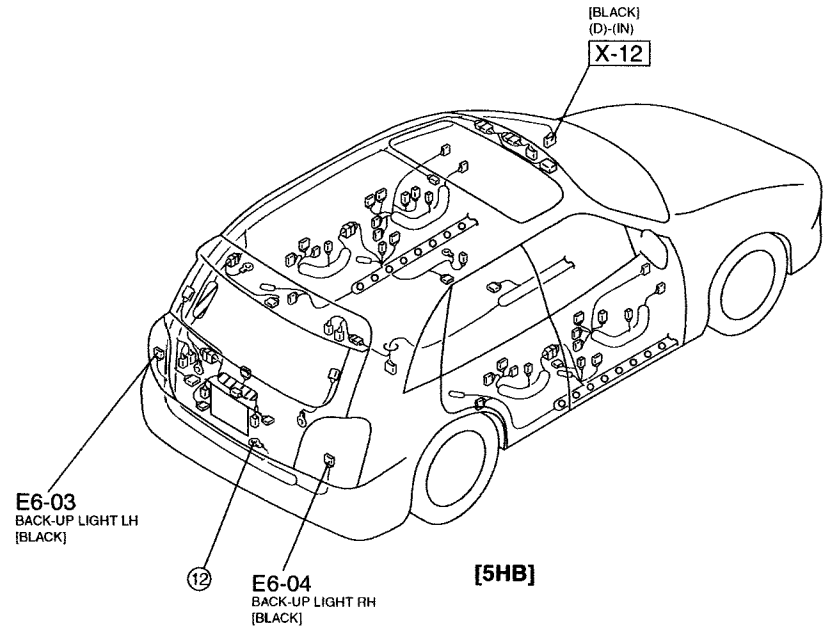
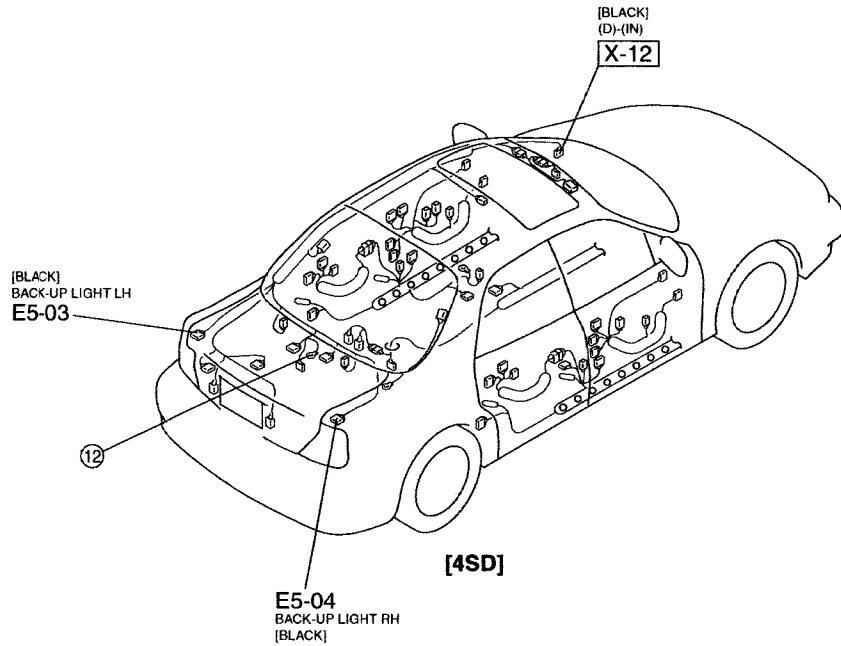
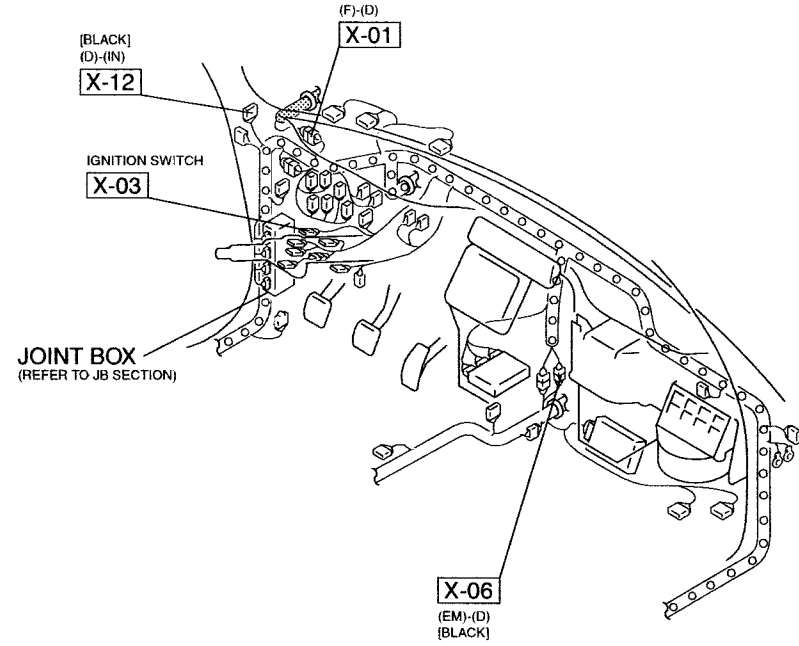
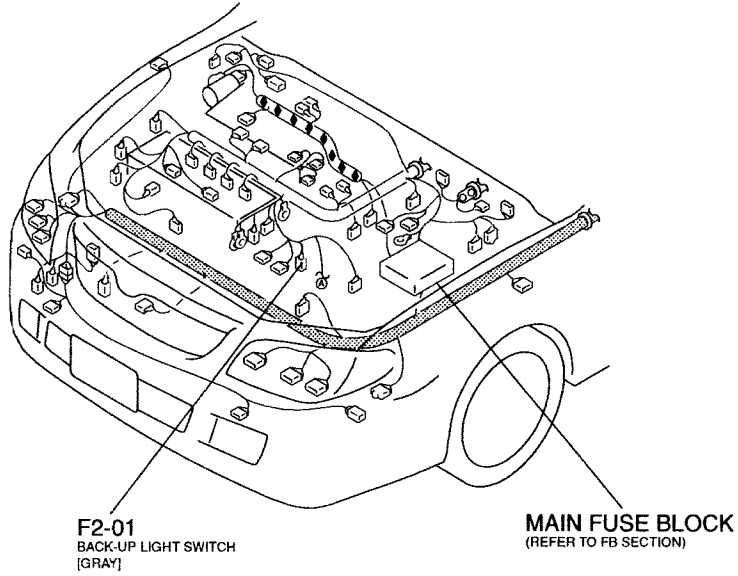



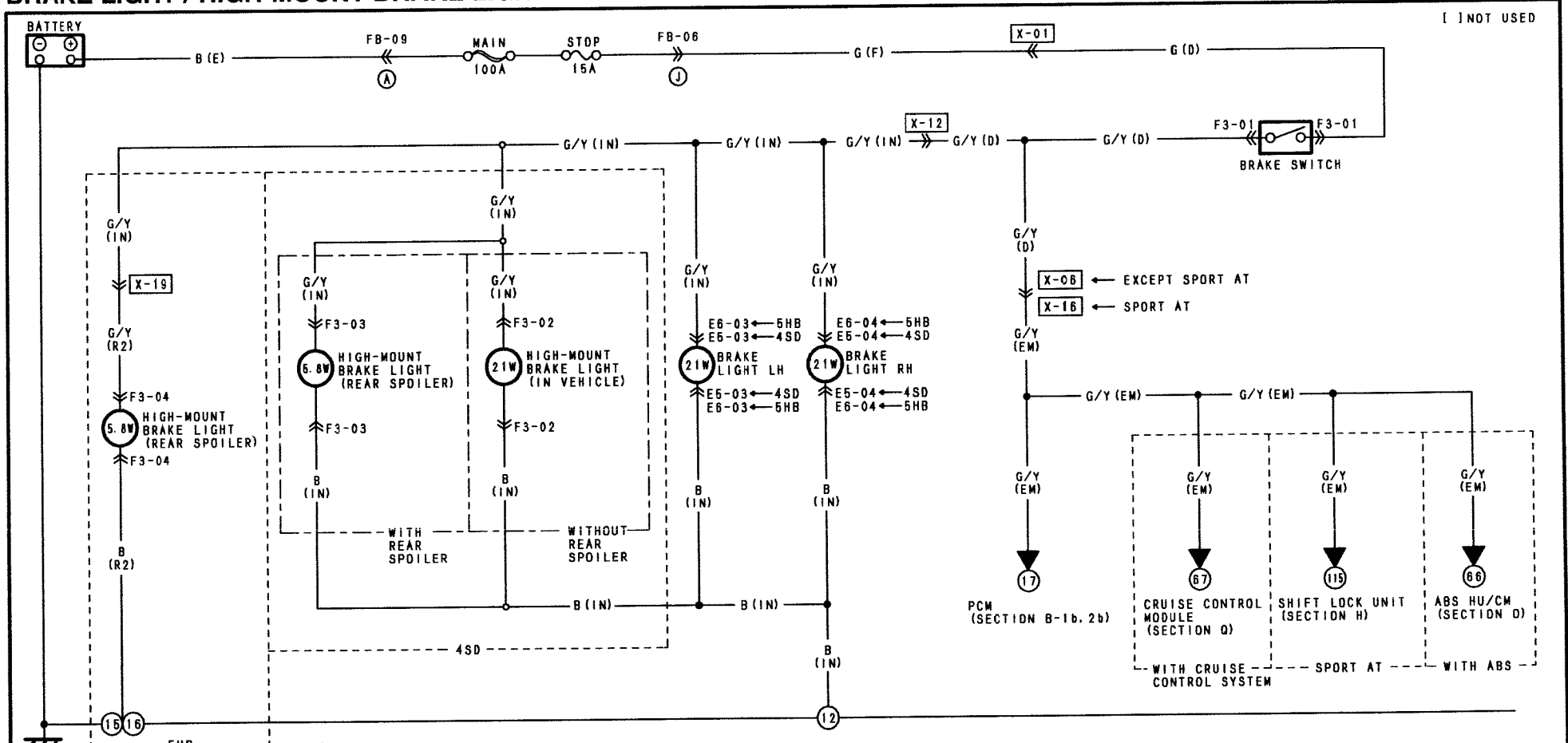

**BRAKE LIGHT / HIGH-MOUNT BRAKE LIGHT**

42

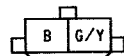
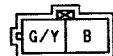
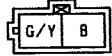

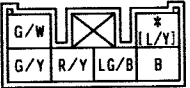
<p>F3-01 BRAKE SWITCH (D)</p> 	<p>F3-02 HIGH-MOUNT BRAKE LIGHT (IN VEHICLE) (IN)</p>  <p>(4SD: WITHOUT REAR SPOILER)</p>	<p>F3-03 HIGH-MOUNT BRAKE LIGHT (REAR SPOILER) (IN)</p>  <p>(4SD: WITH REAR SPOILER)</p>	<p>F3-04 HIGH-MOUNT BRAKE LIGHT (REAR SPOILER) (R2)</p>  <p>(5HB)</p>
<p>E5-03 BRAKE LIGHT LH (IN) E6-03 4SD 5HB</p> 	<p>E5-04 BRAKE LIGHT RH (IN) E6-04 4SD 5HB</p> 		

HARNESS SYMBOL :  (F)  (E)  (D)  (R)

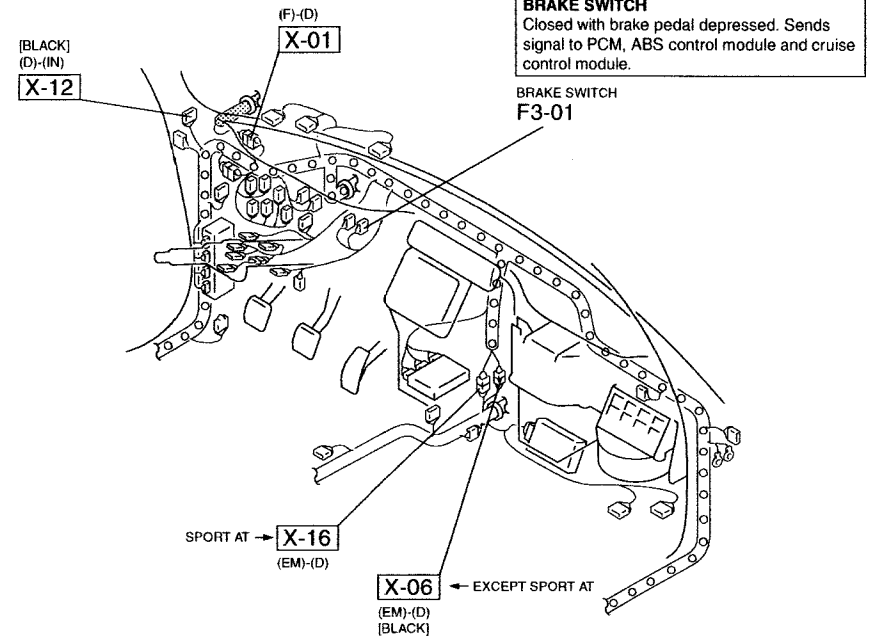
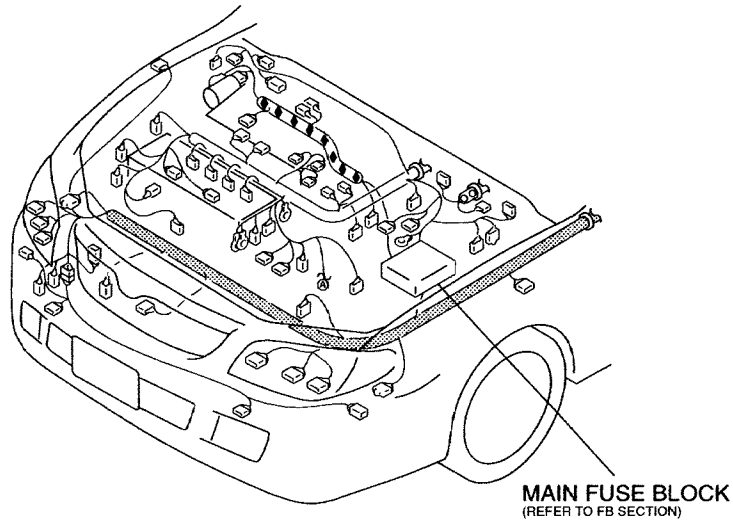

43

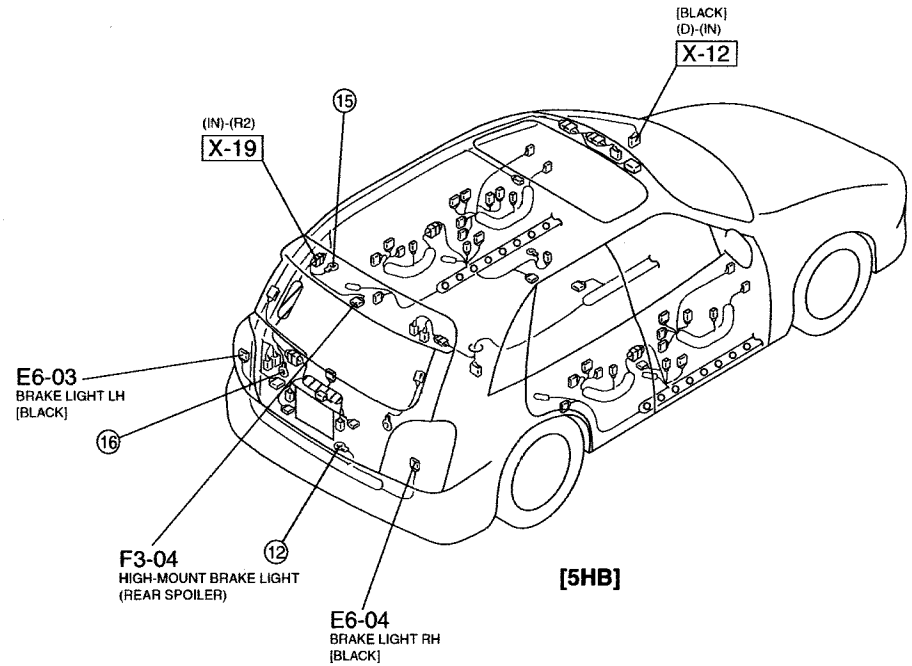
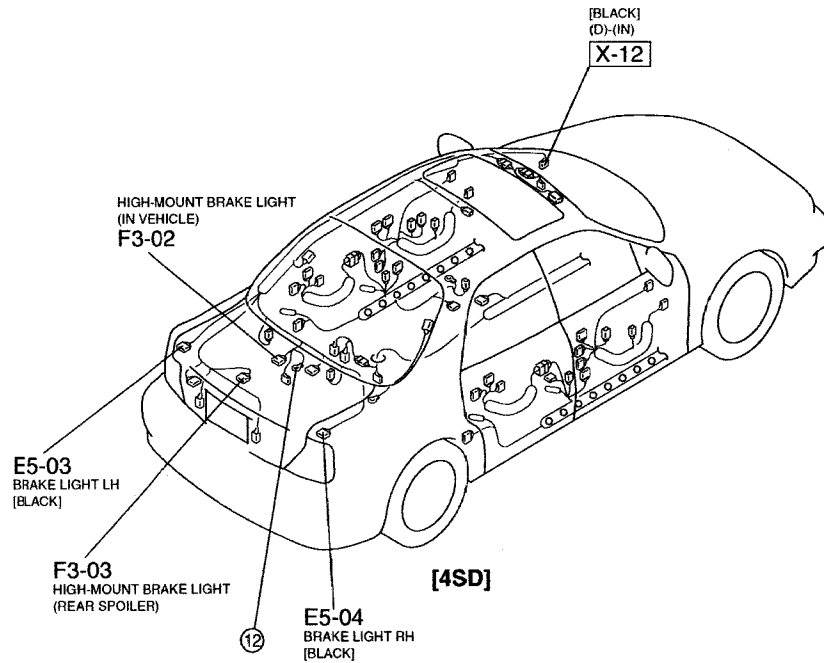

HEATER AND AIR CONDITIONER

44

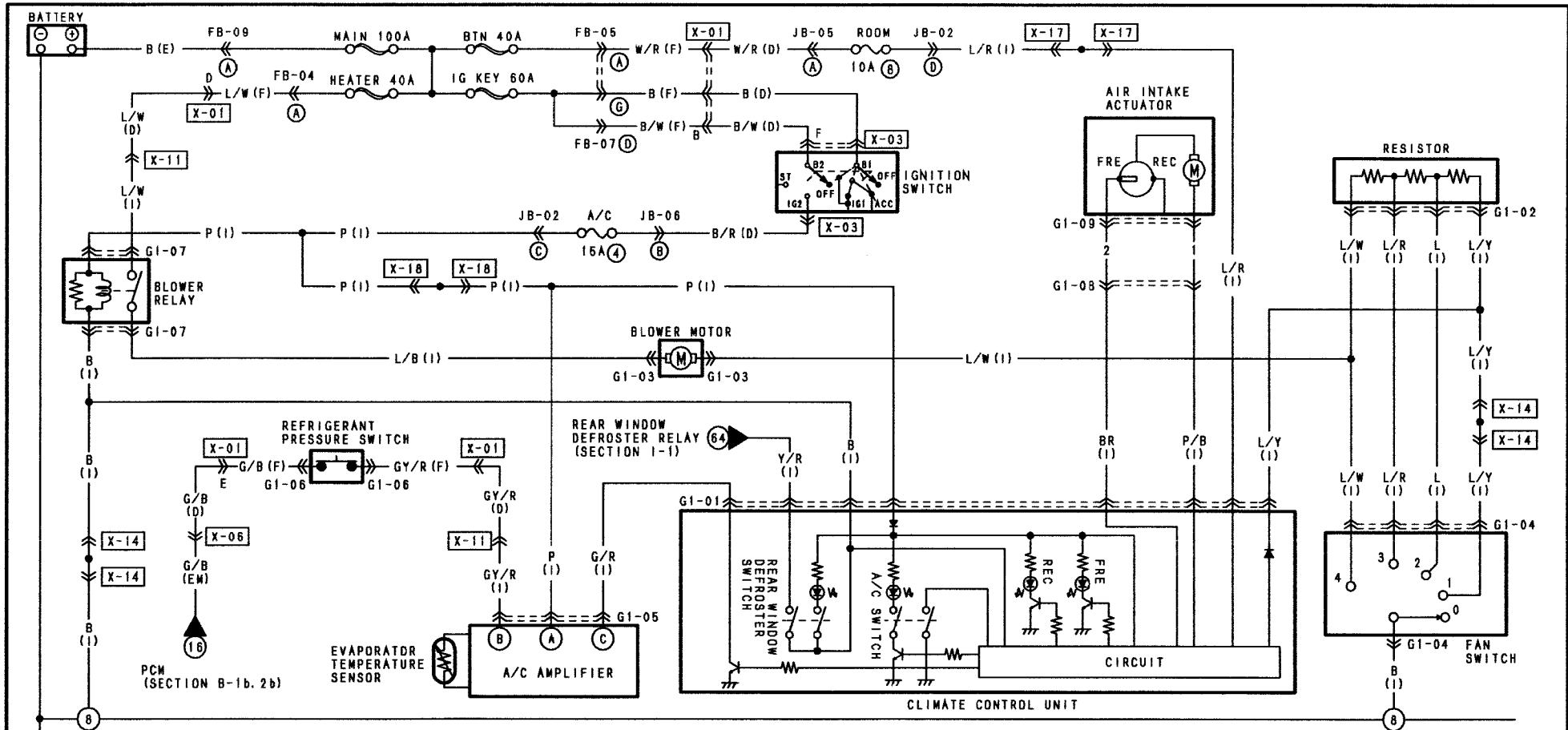

<p>G1-01 CLIMATE CONTROL UNIT (1)</p> <table border="1" style="margin-left: auto; margin-right: auto;"> <tr> <td>L/R</td> <td>P/B</td> <td>*</td> <td>B</td> <td>*</td> <td>BR</td> </tr> <tr> <td>P</td> <td>Y/R</td> <td>LG/B</td> <td>W/L</td> <td>L/Y</td> <td>G/R</td> </tr> </table>	L/R	P/B	*	B	*	BR	P	Y/R	LG/B	W/L	L/Y	G/R	<p>G1-02 RESISTOR (1)</p> <table border="1" style="margin-left: auto; margin-right: auto;"> <tr> <td>L/W</td> <td>L</td> <td>L/Y</td> <td>L/R</td> </tr> <tr> <td>*</td> <td>*</td> <td>*</td> <td>*</td> </tr> </table>	L/W	L	L/Y	L/R	*	*	*	*	<p>G1-03 BLOWER MOTOR (1)</p> <table border="1" style="margin-left: auto; margin-right: auto;"> <tr> <td>L/B</td> </tr> <tr> <td>L/W</td> </tr> </table>	L/B	L/W	<p>G1-04 FAN SWITCH (1)</p> <table border="1" style="margin-left: auto; margin-right: auto;"> <tr> <td>L</td> <td>L/Y</td> <td>B</td> </tr> <tr> <td>L/R</td> <td>L/W</td> <td>*</td> </tr> </table>	L	L/Y	B	L/R	L/W	*	<p>G1-05 A/C AMPLIFIER (1)</p> <table border="1" style="margin-left: auto; margin-right: auto;"> <tr> <td>*</td> <td>*</td> <td>*</td> <td>G/R</td> <td>GY/R</td> <td>P</td> </tr> <tr> <td>F</td> <td>E</td> <td>D</td> <td>C</td> <td>B</td> <td>A</td> </tr> </table>	*	*	*	G/R	GY/R	P	F	E	D	C	B	A
L/R	P/B	*	B	*	BR																																							
P	Y/R	LG/B	W/L	L/Y	G/R																																							
L/W	L	L/Y	L/R																																									
*	*	*	*																																									
L/B																																												
L/W																																												
L	L/Y	B																																										
L/R	L/W	*																																										
*	*	*	G/R	GY/R	P																																							
F	E	D	C	B	A																																							
<p>G1-06 REFRIGERANT PRESSURE SWITCH (F)</p>	<p>G1-07 BLOWER RELAY (1)</p>	<p>G1-08 INSTRUMENT PANEL (1) - SHORT CORD</p> <p>(SHORT CORD)</p> <p>NOTE: TERMINALS OF THIS CONNECTOR ARE INDICATED BY NUMBERS.</p>	<p>G1-09 AIR INTAKE ACTUATOR (SHORT CORD)</p> <p>NOTE: TERMINALS OF THIS CONNECTOR ARE INDICATED BY NUMBERS.</p>																																									

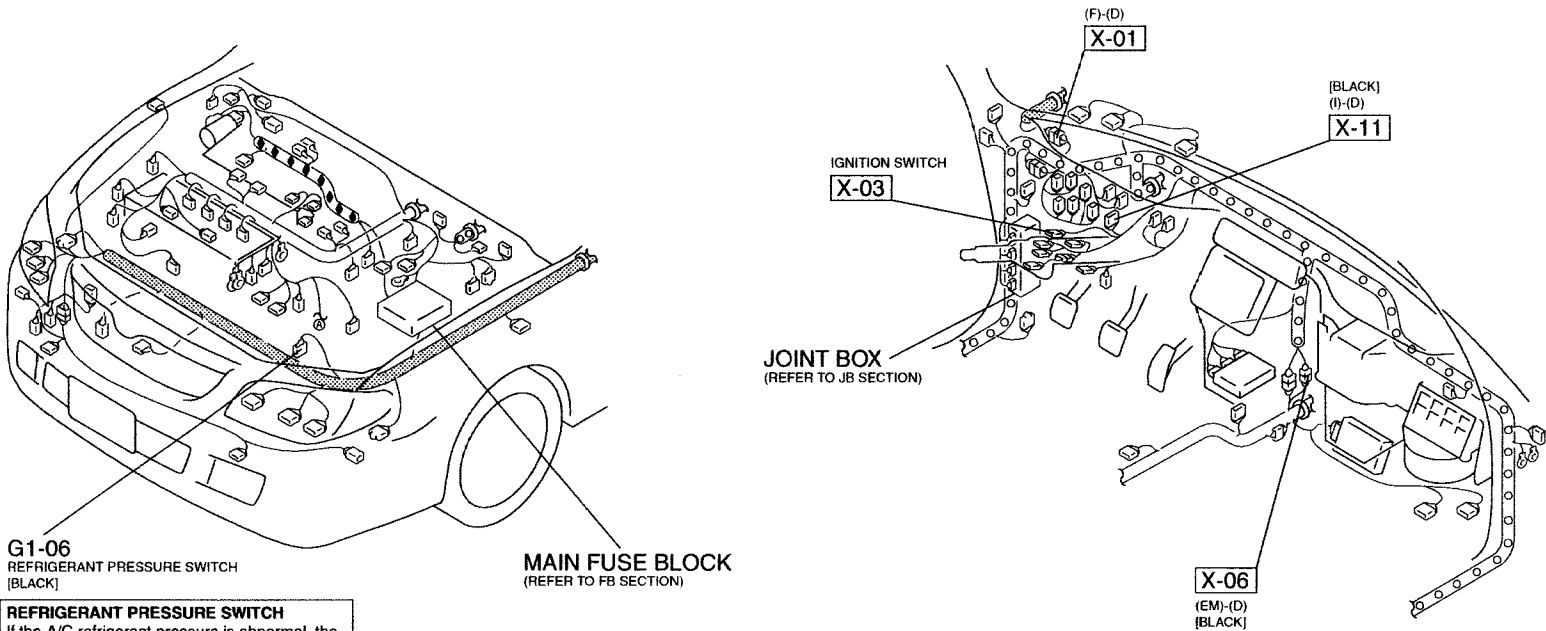

**REFRIGERANT PRESSURE SWITCH**  
If the A/C refrigerant pressure is abnormal, the refrigerant pressure switches (Hi or Lo) cut the A/C signal sent from the heater control unit to the PCM, thereby stopping the A/C compressor.

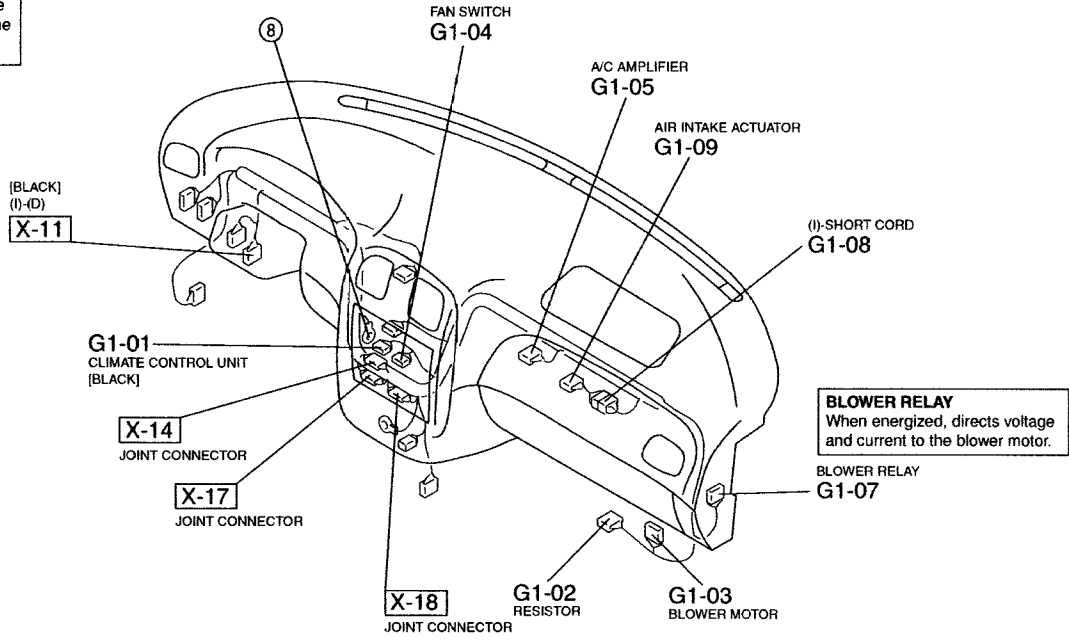

# SPORT AT CONTROL SYSTEM

H

46

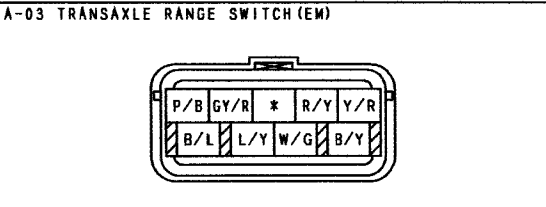
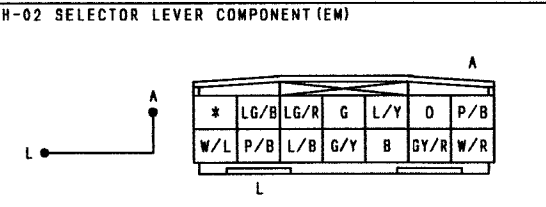
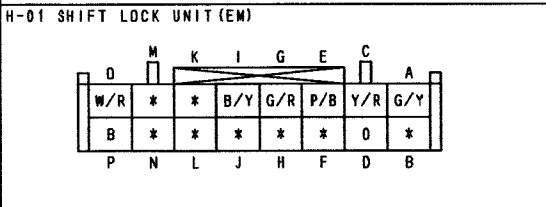
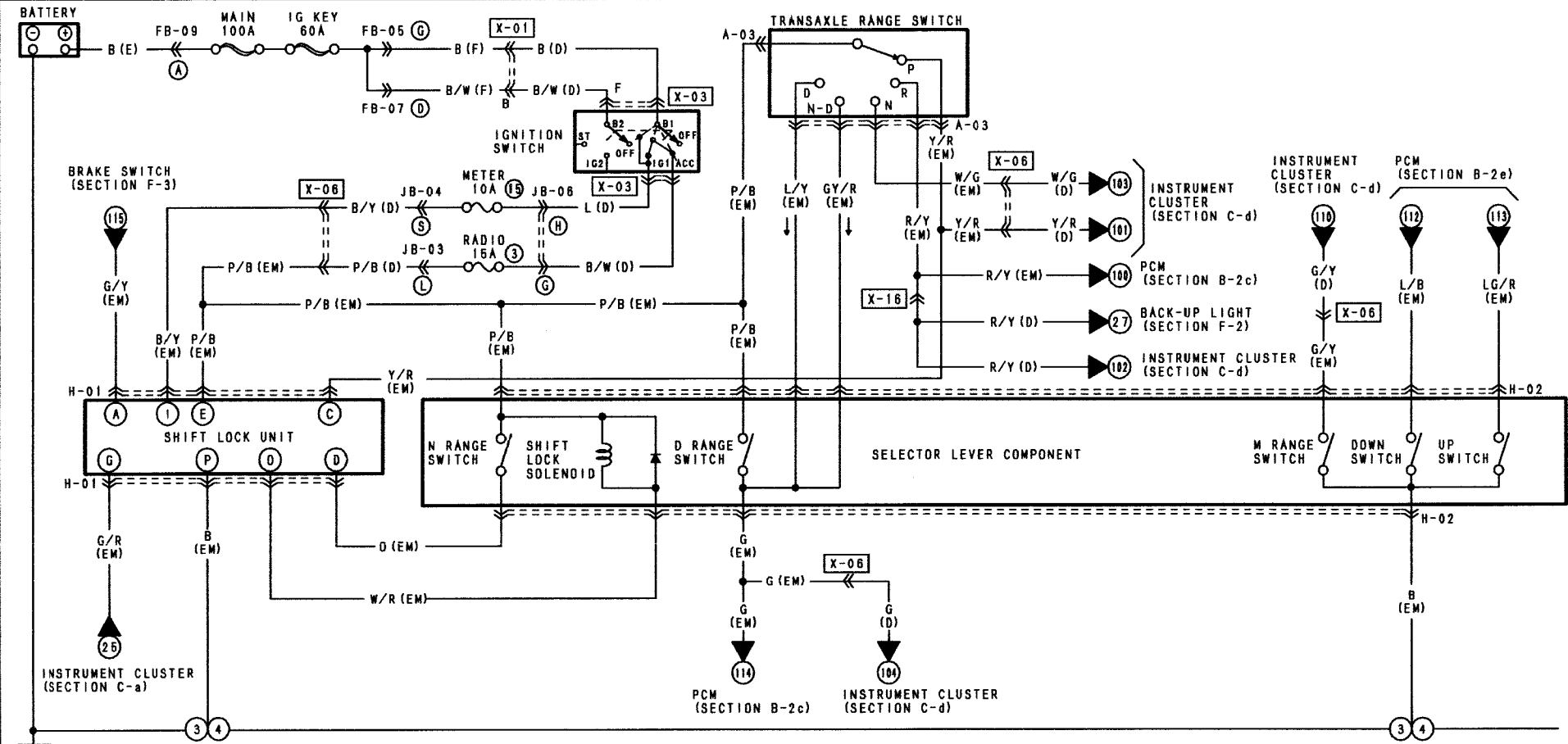

HARNESS SYMBOL :  (F)  (E)  (D)  (R)

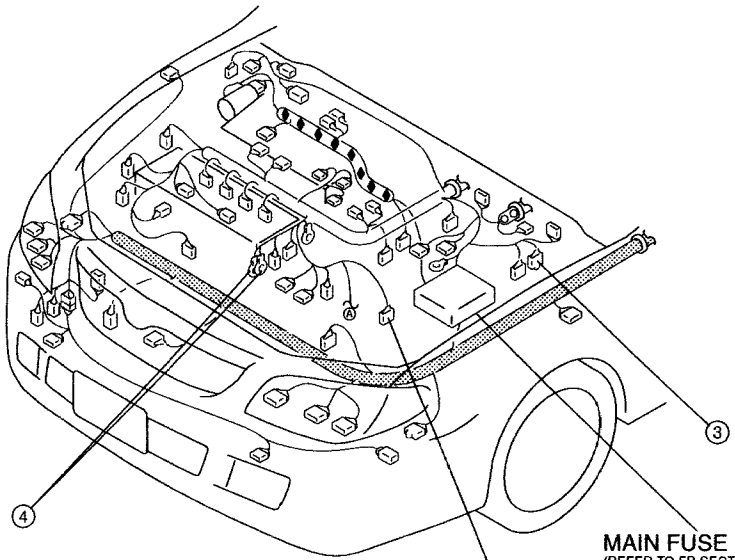

**MAIN FUSE BLOCK**  
(REFER TO FB SECTION)

**A-03**  
TRANSAXLE RANGE SWITCH

**TRANSAXLE RANGE SWITCH**  
Detects selector lever position.

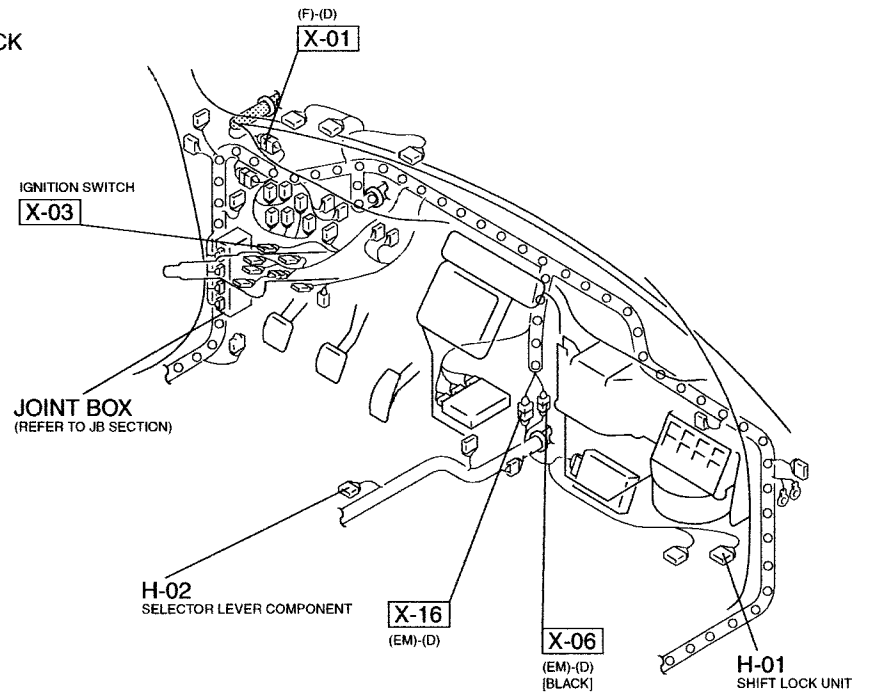

(F)-(D)  
**X-01**

IGNITION SWITCH  
**X-03**

**JOINT BOX**  
(REFER TO JB SECTION)

**H-02**  
SELECTOR LEVER COMPONENT

**X-16**  
(EM)-(D)

**X-06**  
(EM)-(D)  
[BLACK]

**H-01**  
SHIFT LOCK UNIT

# CARGO COMPARTMENT LIGHT (5HB) / CIGARETTE LIGHTER / REAR WINDOW DEFROSTER / TRUNK COMPARTMENT LIGHT (4SD)

48

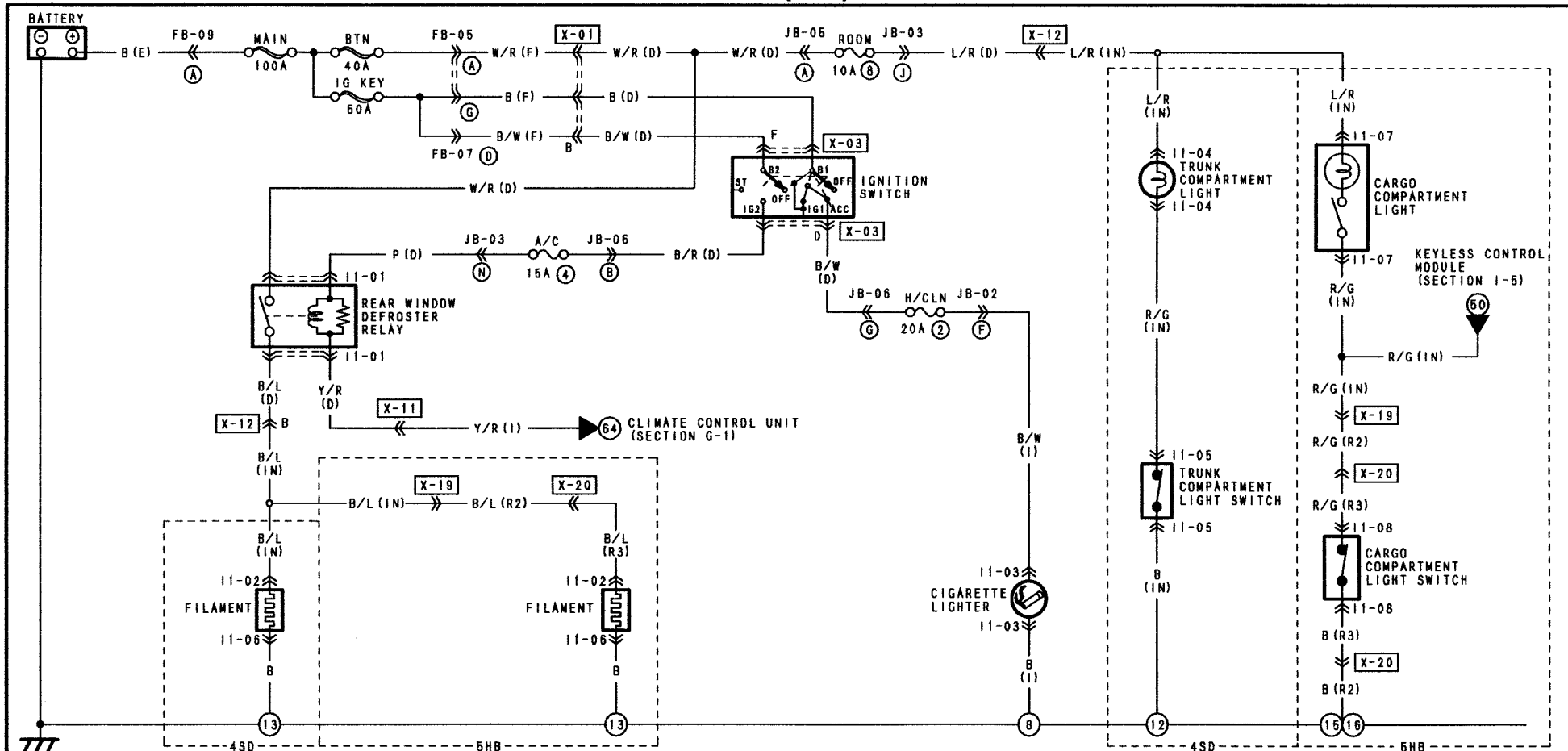

<p>11-01 REAR WINDOW DEFROSTER RELAY (D)</p>	<p>11-02 FILAMENT (IN) (R3)</p> <p>4SD </p> <p>5HB </p>	<p>11-03 CIGARETTE LIGHTER (I)</p>	<p>11-04 TRUNK COMPARTMENT LIGHT (IN)</p> <p>(4SD)</p>	<p>11-05 TRUNK COMPARTMENT LIGHT SWITCH (IN)</p> <p>(4SD)</p>	<p>11-06 FILAMENT (SHORT CORD)</p>	<p>11-07 CARGO COMPARTMENT LIGHT (IN)</p> <p>(5HB)</p>
<p>11-08 CARGO COMPARTMENT LIGHT SWITCH (R3)</p> <p>(5HB)</p>						

HARNESS SYMBOL :  (F)  (E)  (D)  (R)

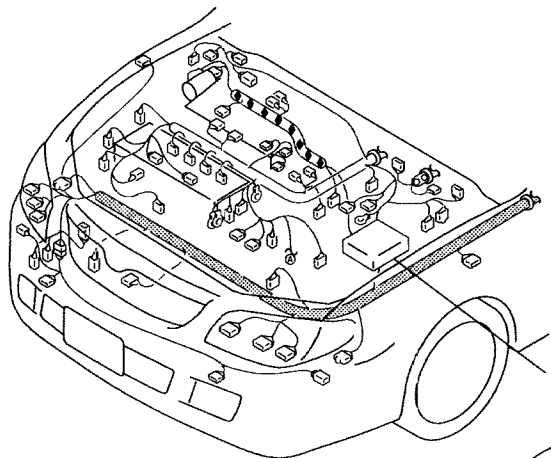

**MAIN FUSE BLOCK**  
(REFER TO FB SECTION)

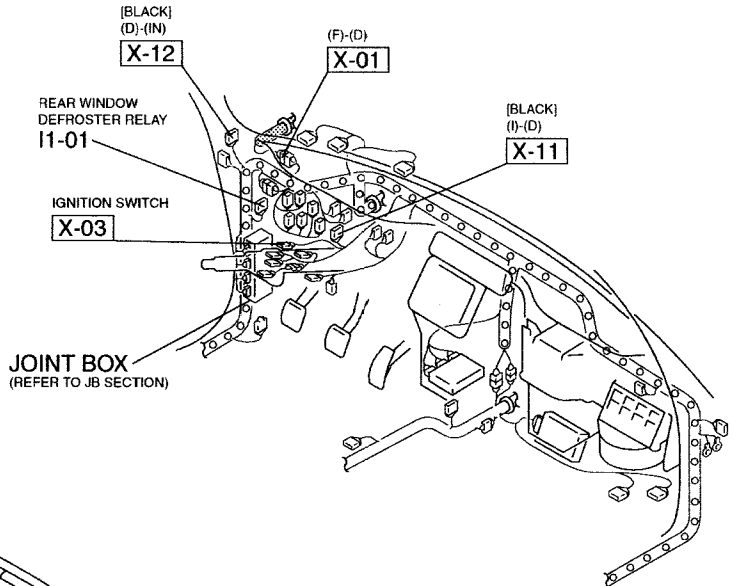

REAR WINDOW DEFROSTER RELAY  
I1-01

IGNITION SWITCH  
X-03

**JOINT BOX**  
(REFER TO JB SECTION)

[BLACK]  
(D)-(IN)  
X-12

(F)-(D)  
X-01

[BLACK]  
(I)-(D)  
X-11

49

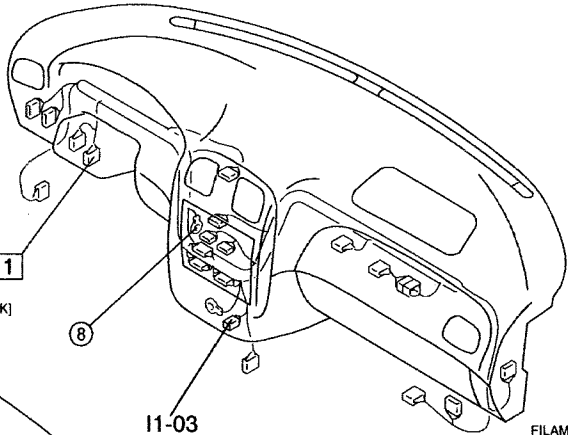

[BLACK]  
(I)-(D)  
[BLACK]  
X-11

8

I1-03  
CIGARETTE LIGHTER  
[BLACK]

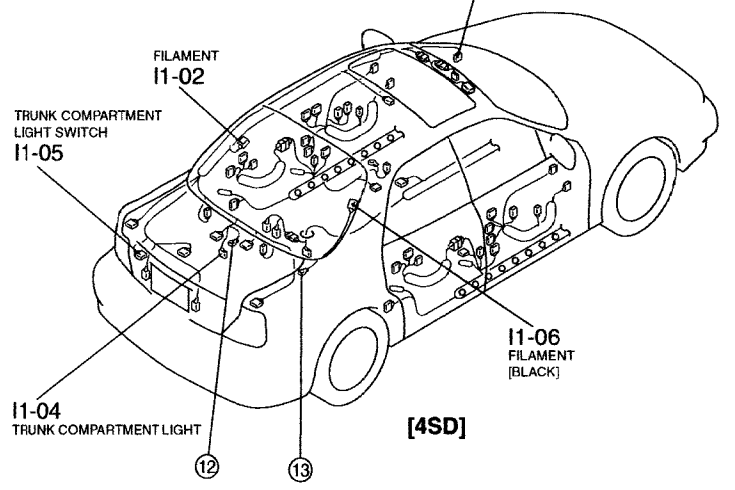

TRUNK COMPARTMENT LIGHT SWITCH  
I1-05

FILAMENT  
I1-02

[BLACK]  
(D)-(IN)  
X-12

I1-04  
TRUNK COMPARTMENT LIGHT

I1-06  
FILAMENT  
[BLACK]

[4SD]

12

13

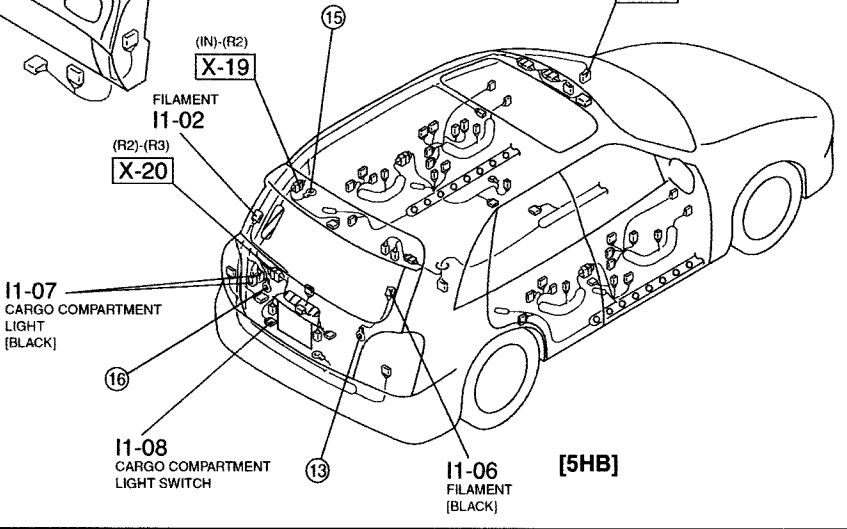

(IN)-(R2)  
X-19

15

FILAMENT  
I1-02

(R2)-(R3)  
X-20

[BLACK]  
(D)-(IN)  
X-12

I1-07  
CARGO COMPARTMENT LIGHT  
[BLACK]

16

I1-08  
CARGO COMPARTMENT LIGHT SWITCH

I1-06  
FILAMENT  
[BLACK]

[5HB]

13



ILLUMINATION LIGHT

50

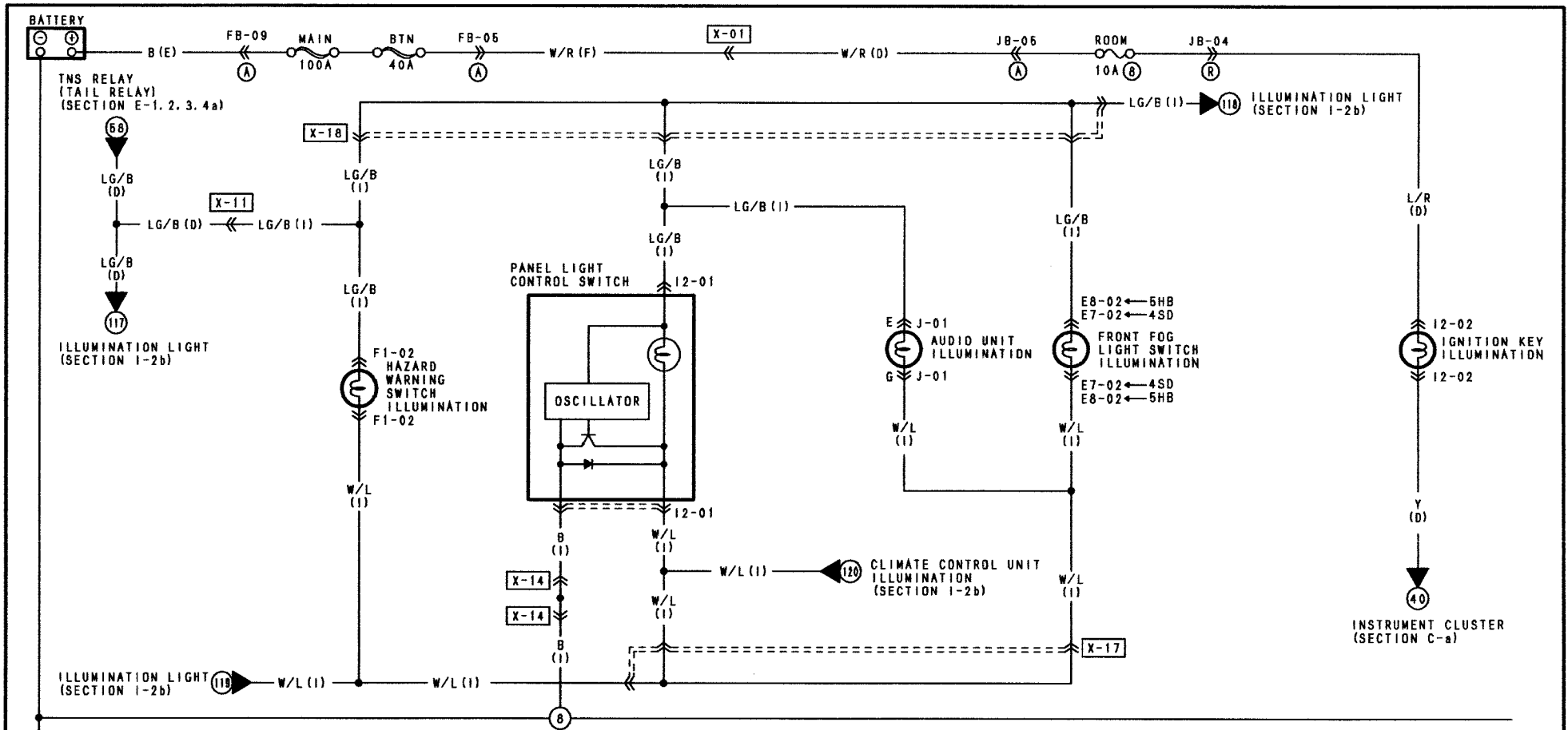

777

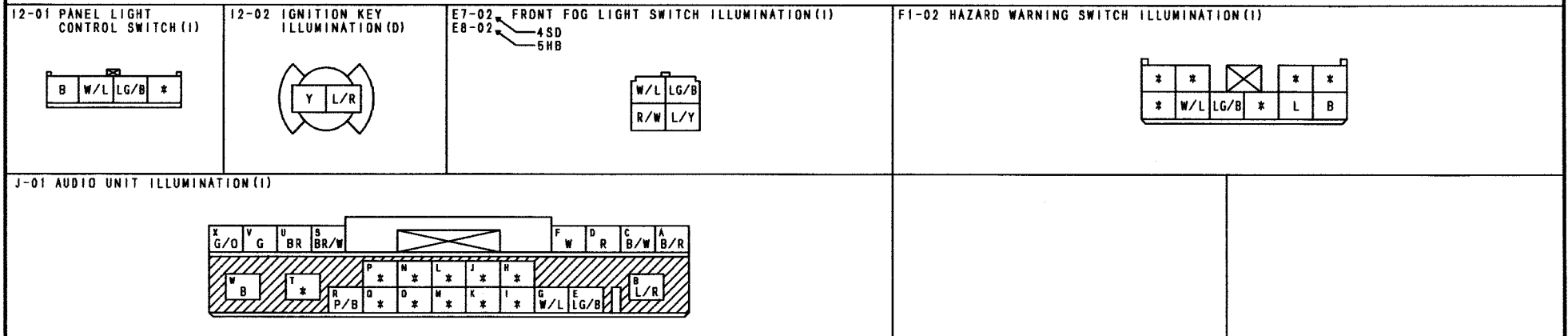

HARNESS SYMBOL :  (F)  (E)  (D)  (R)

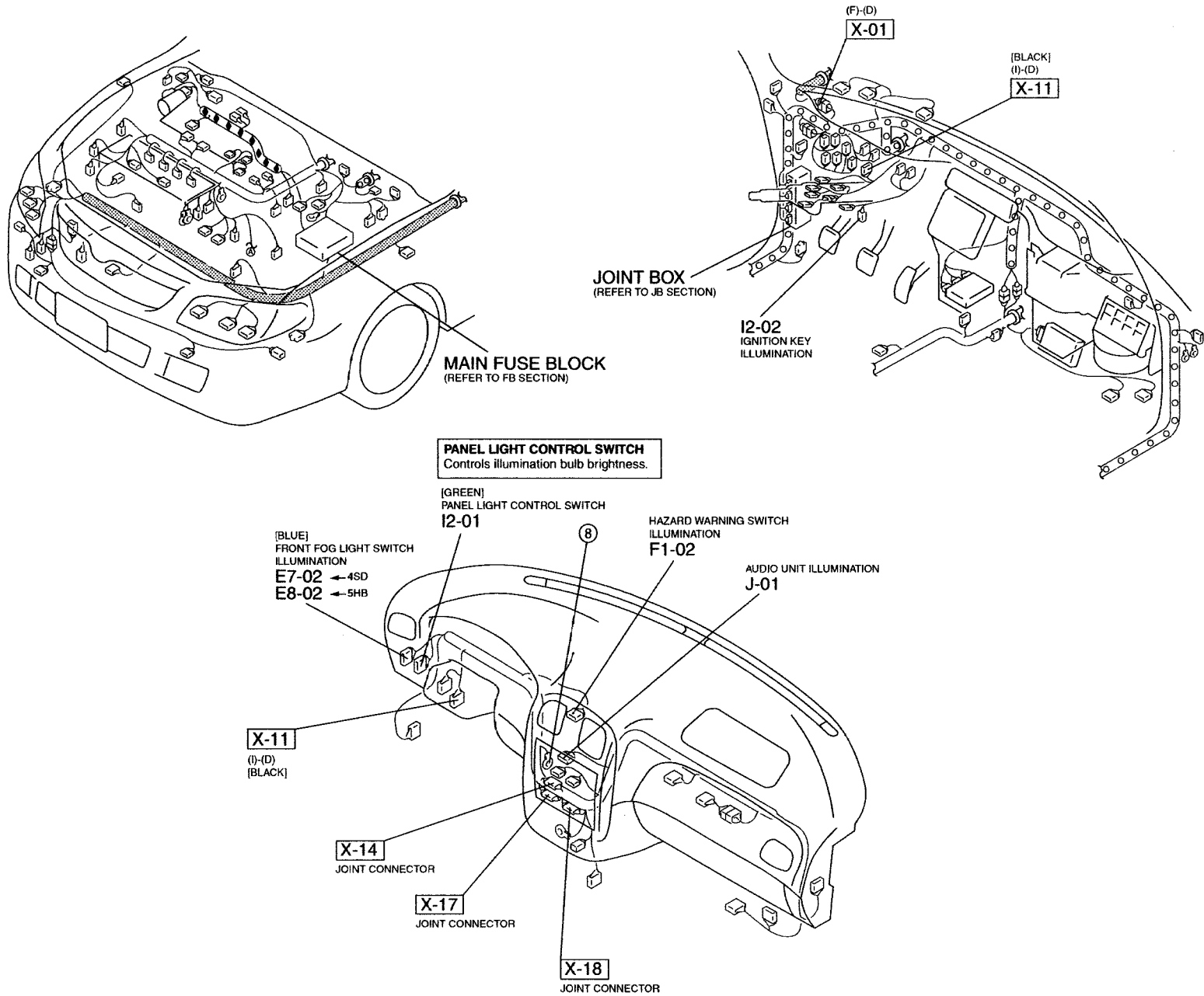

ILLUMINATION LIGHT

52

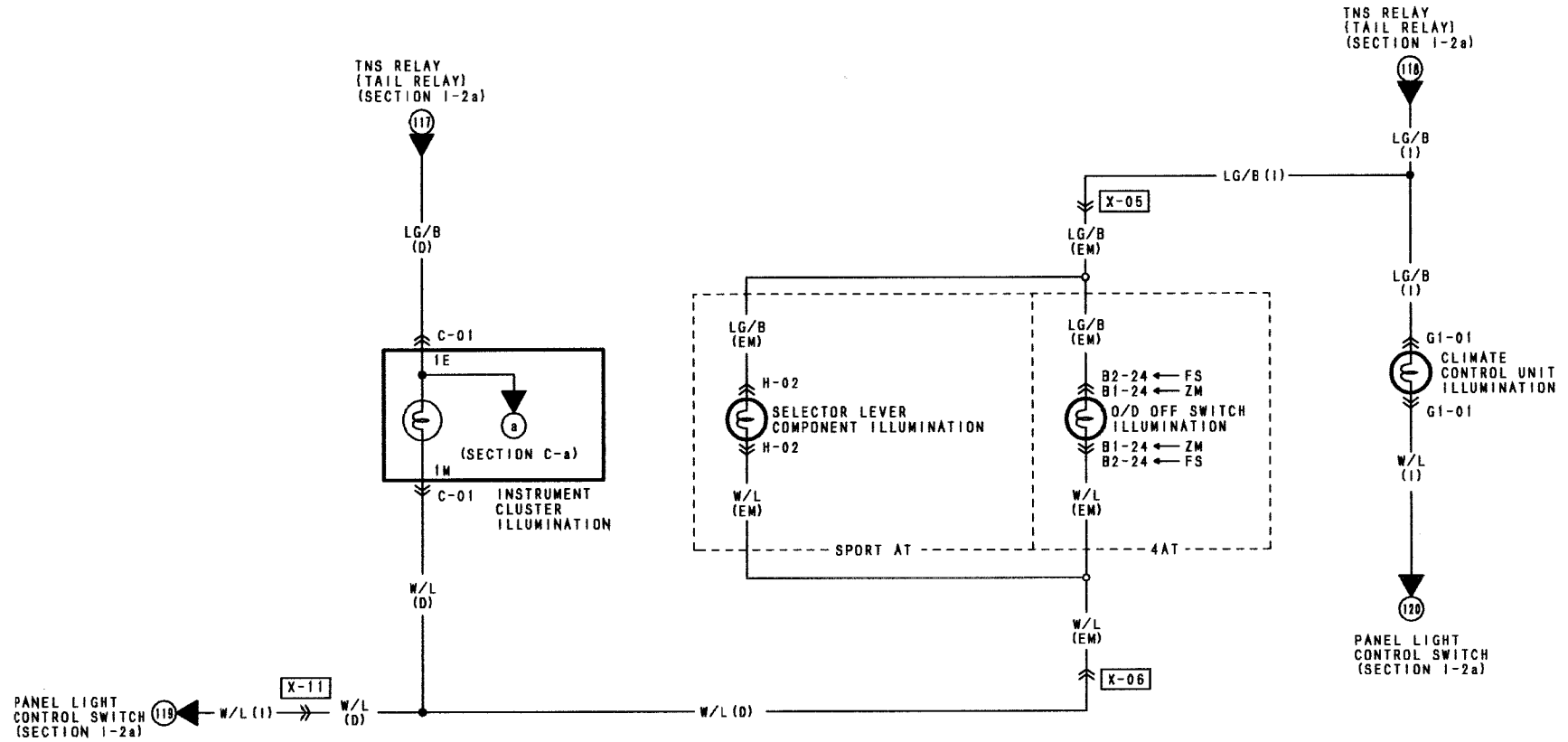

TTT

<p>B1-24 O/D OFF SWITCH ILLUMINATION (EM) B2-24</p> <table border="1" data-bbox="442 1113 553 1207"> <tr> <td>G/D</td> <td>LG/B</td> </tr> <tr> <td>B</td> <td>W/L</td> </tr> </table> <p>(4AT)</p>	G/D	LG/B	B	W/L	<p>C-01 INSTRUMENT CLUSTER ILLUMINATION (D)</p> <table border="1" data-bbox="840 1081 1238 1223"> <tr> <td>1Q</td> <td>1D</td> <td>1M</td> <td>1K</td> <td>1I</td> <td>1G</td> <td>1E</td> <td>1C</td> <td>1A</td> </tr> <tr> <td>Y</td> <td>L/R</td> <td>W/L</td> <td>Y/B</td> <td>B/L</td> <td>BR/B</td> <td>LG/B</td> <td>*</td> <td>B</td> </tr> <tr> <td>BR/R</td> <td>L</td> <td>L/O</td> <td>LG/R</td> <td>B/Y</td> <td>Y/R</td> <td>R</td> <td>B</td> <td>G/W</td> </tr> <tr> <td>1R</td> <td>1P</td> <td>1N</td> <td>1L</td> <td>1J</td> <td>1H</td> <td>1F</td> <td>1D</td> <td>1B</td> </tr> </table>	1Q	1D	1M	1K	1I	1G	1E	1C	1A	Y	L/R	W/L	Y/B	B/L	BR/B	LG/B	*	B	BR/R	L	L/O	LG/R	B/Y	Y/R	R	B	G/W	1R	1P	1N	1L	1J	1H	1F	1D	1B	<p>G1-01 CLIMATE CONTROL UNIT ILLUMINATION (I)</p> <table border="1" data-bbox="1459 1113 1725 1199"> <tr> <td>L/R</td> <td>P/B</td> <td>*</td> <td>B</td> <td>*</td> <td>BR</td> </tr> <tr> <td>P</td> <td>Y/R</td> <td>LG/B</td> <td>W/L</td> <td>L/Y</td> <td>G/R</td> </tr> </table>	L/R	P/B	*	B	*	BR	P	Y/R	LG/B	W/L	L/Y	G/R	
G/D	LG/B																																																						
B	W/L																																																						
1Q	1D	1M	1K	1I	1G	1E	1C	1A																																															
Y	L/R	W/L	Y/B	B/L	BR/B	LG/B	*	B																																															
BR/R	L	L/O	LG/R	B/Y	Y/R	R	B	G/W																																															
1R	1P	1N	1L	1J	1H	1F	1D	1B																																															
L/R	P/B	*	B	*	BR																																																		
P	Y/R	LG/B	W/L	L/Y	G/R																																																		
<p>H-02 SELECTOR LEVER COMPONENT ILLUMINATION (EM)</p> <table border="1" data-bbox="398 1301 707 1411"> <tr> <td>*</td> <td>LG/B</td> <td>LG/R</td> <td>G</td> <td>L/Y</td> <td>D</td> <td>P/B</td> </tr> <tr> <td>W/L</td> <td>P/B</td> <td>L/B</td> <td>G/Y</td> <td>B</td> <td>GY/R</td> <td>W/R</td> </tr> </table> <p>(SPORT AT)</p>	*	LG/B	LG/R	G	L/Y	D	P/B	W/L	P/B	L/B	G/Y	B	GY/R	W/R																																									
*	LG/B	LG/R	G	L/Y	D	P/B																																																	
W/L	P/B	L/B	G/Y	B	GY/R	W/R																																																	

HARNESS SYMBOL :  (F)  (E)  (D)  (R)

53

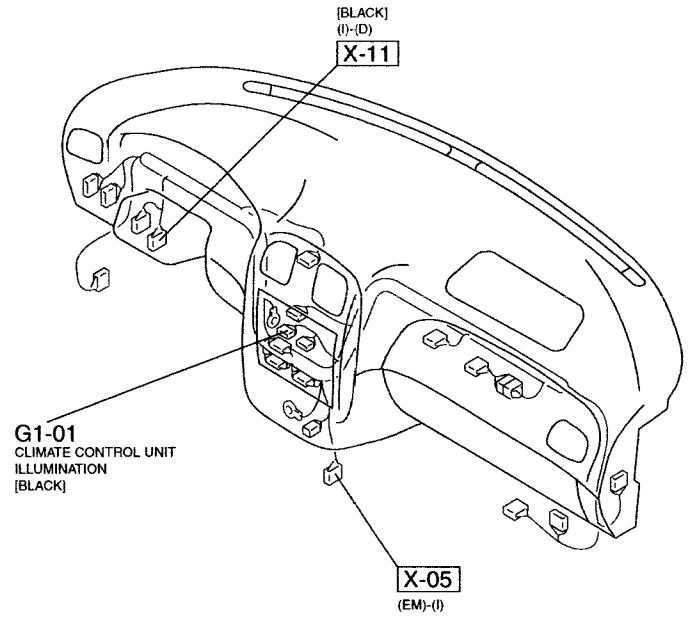
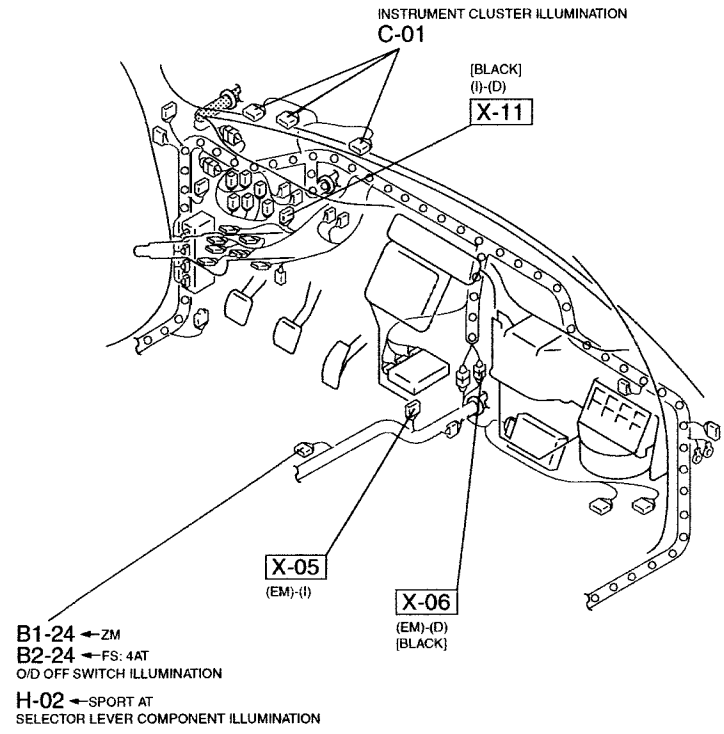

AUDIO SYSTEM

< > WITHOUT POWER DOOR LOCK SYSTEM  
 [ ] NOT USED

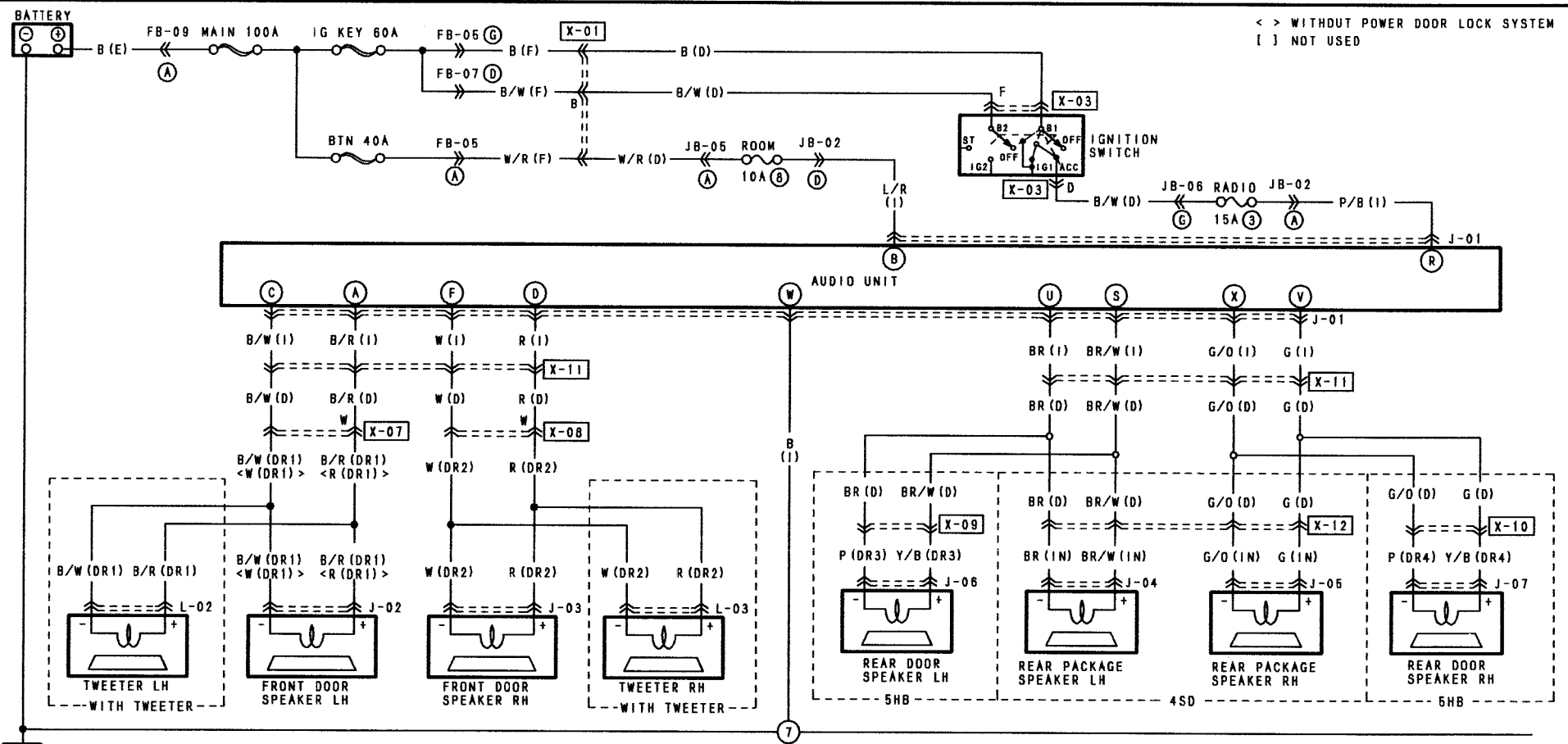

54

TTT

<p>J-01 AUDIO UNIT (1)</p>	<p>J-02 FRONT DOOR SPEAKER LH (DR1)</p>	<p>J-03 FRONT DOOR SPEAKER RH (DR2)</p>	<p>J-04 REAR PACKAGE SPEAKER LH (1N)</p> <p>(4SD)</p>	<p>J-05 REAR PACKAGE SPEAKER RH (1N)</p> <p>(4SD)</p>
	<p>J-06 REAR DOOR SPEAKER LH (DR3)</p> <p>(5HB)</p>	<p>J-07 REAR DOOR SPEAKER RH (DR4)</p> <p>(5HB)</p>	<p>L-02 TWEETER LH (DR1)</p> <p>(WITH TWEETER)</p>	<p>L-03 TWEETER RH (DR2)</p> <p>(WITH TWEETER)</p>

HARNESS SYMBOL :  (F)  (E)  (D)  (R)

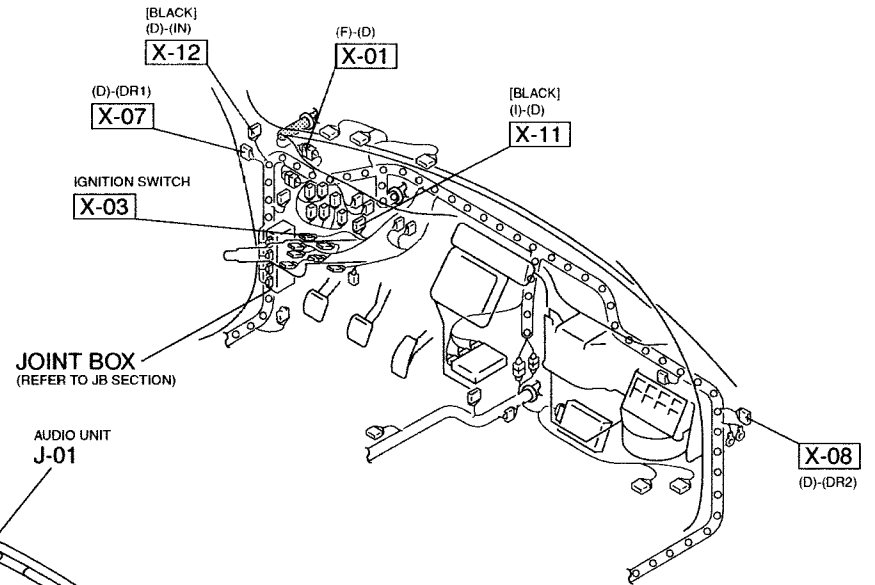
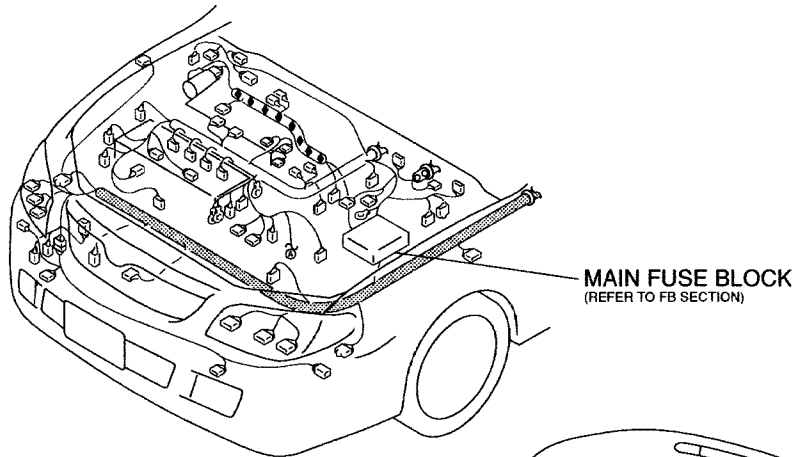

55

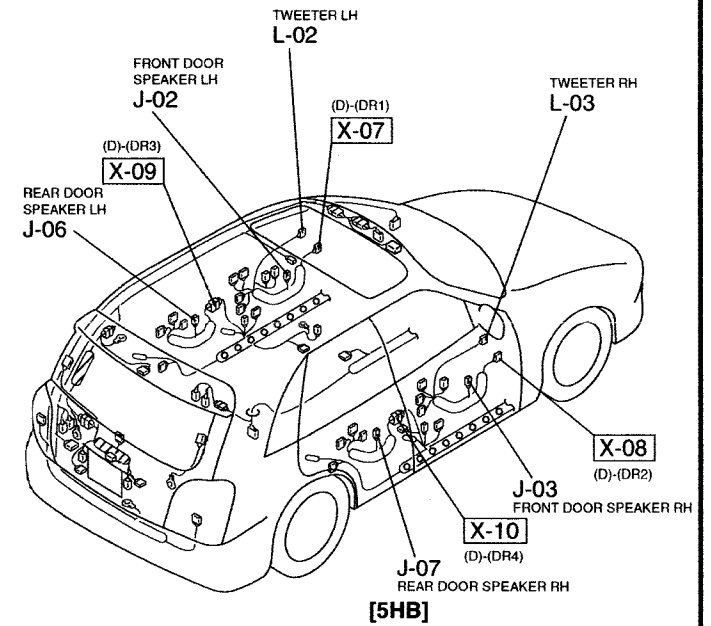
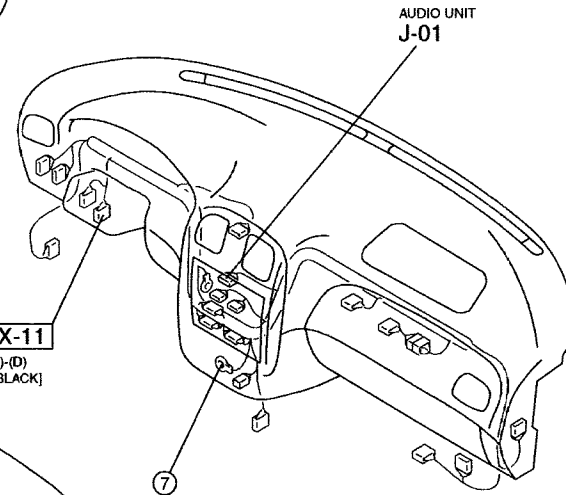
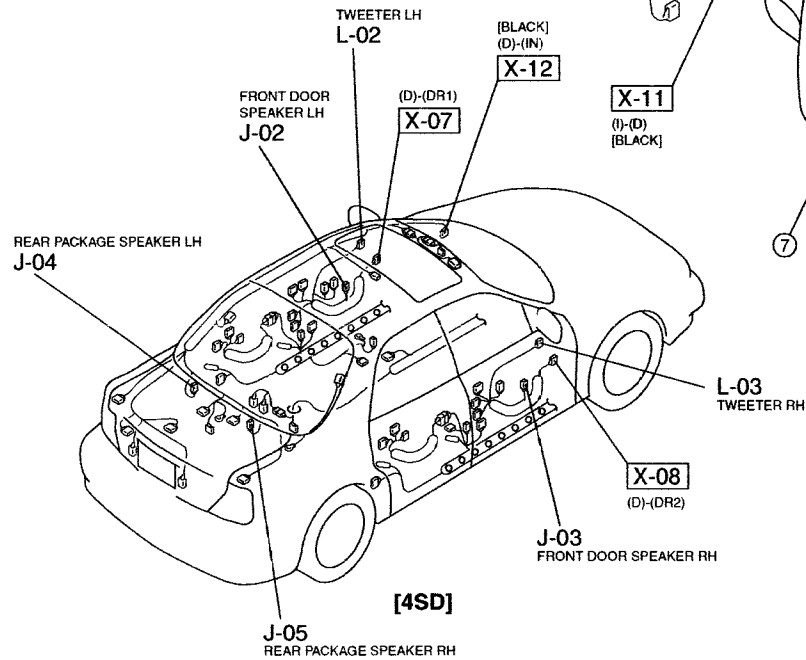

# POWER WINDOW SYSTEM

K-1

56

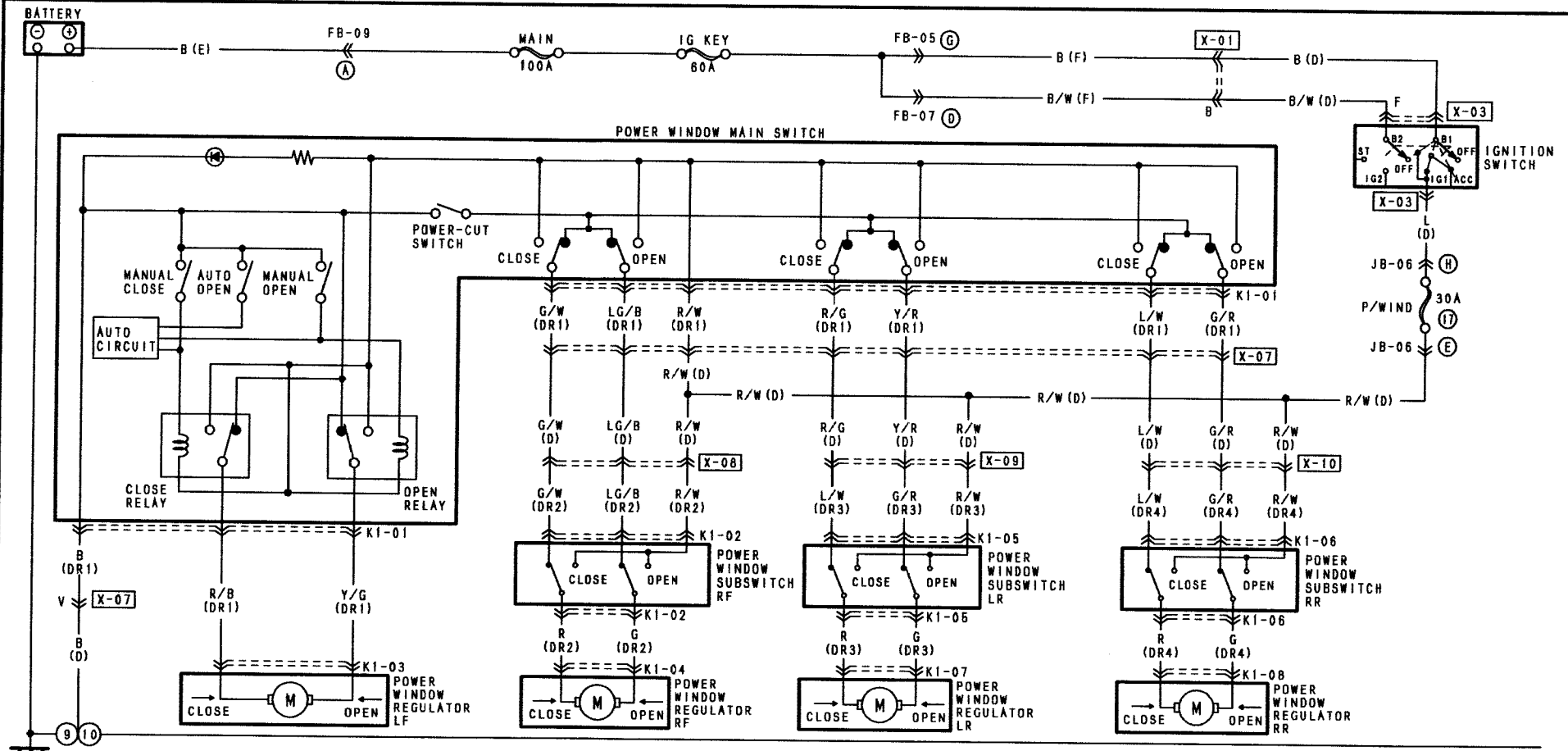

<p>K1-01 POWER WINDOW MAIN SWITCH (DR1)</p>	<p>K1-02 POWER WINDOW SUBSWITCH RF (DR2)</p>	<p>K1-03 POWER WINDOW REGULATOR LF (DR1)</p>	<p>K1-04 POWER WINDOW REGULATOR RF (DR2)</p>
<p>K1-05 POWER WINDOW SUBSWITCH LR (DR3)</p>	<p>K1-06 POWER WINDOW SUBSWITCH RR (DR4)</p>	<p>K1-07 POWER WINDOW REGULATOR LR (DR3)</p>	<p>K1-08 POWER WINDOW REGULATOR RR (DR4)</p>

HARNESS SYMBOL :  (F)  (E)  (D)  (R)

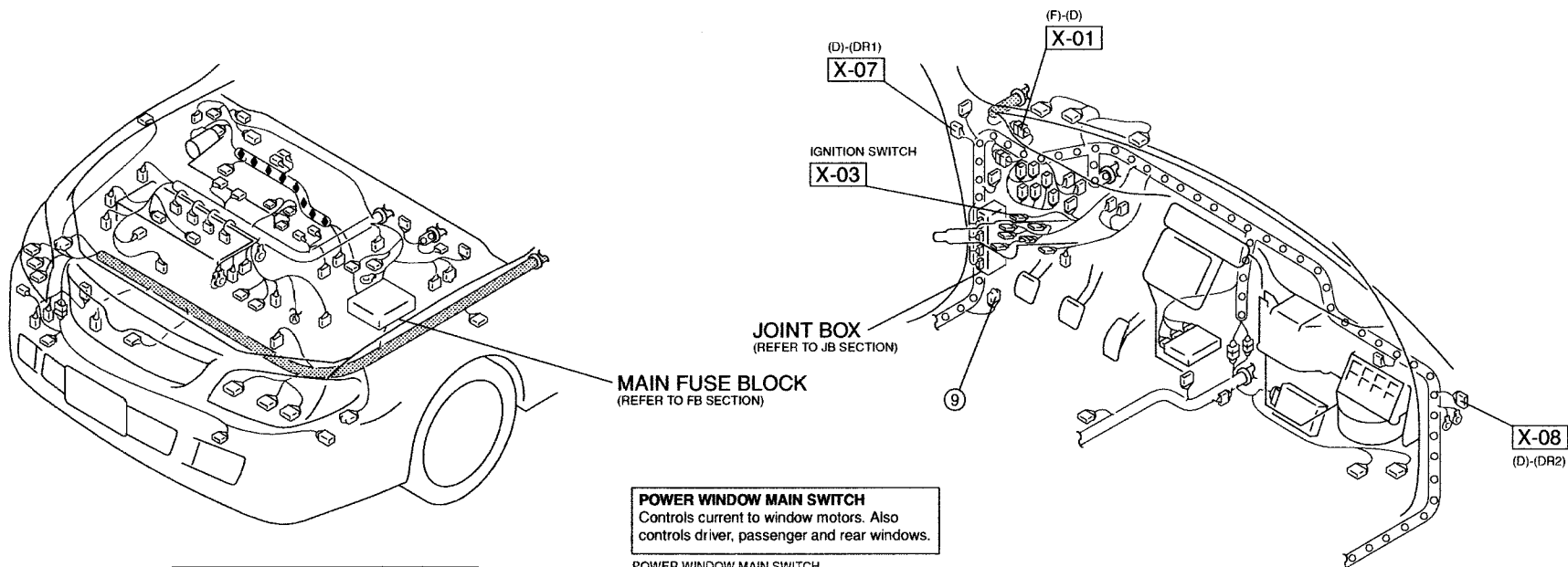

**POWER WINDOW REGULATOR**  
Contains a reversible motor which raises or lowers window according to direction of current flow.

**POWER WINDOW MAIN SWITCH**  
Controls current to window motors. Also controls driver, passenger and rear windows.

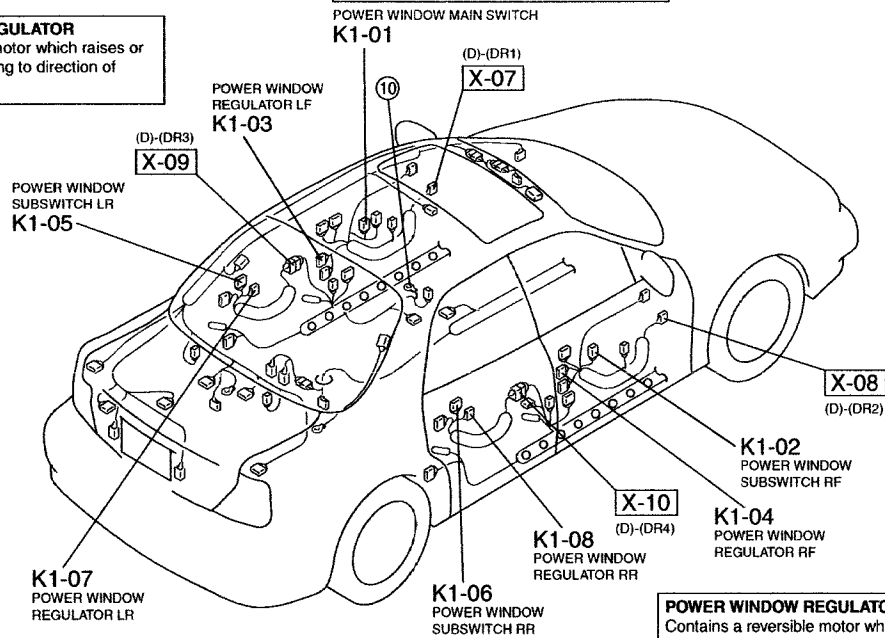

**POWER WINDOW REGULATOR**  
Contains a reversible motor which raises or lowers window according to direction of current flow.

**NOTE : 5HB connector locations are almost the same as the 4SD connector locations.**



# POWER OUTSIDE MIRROR

58

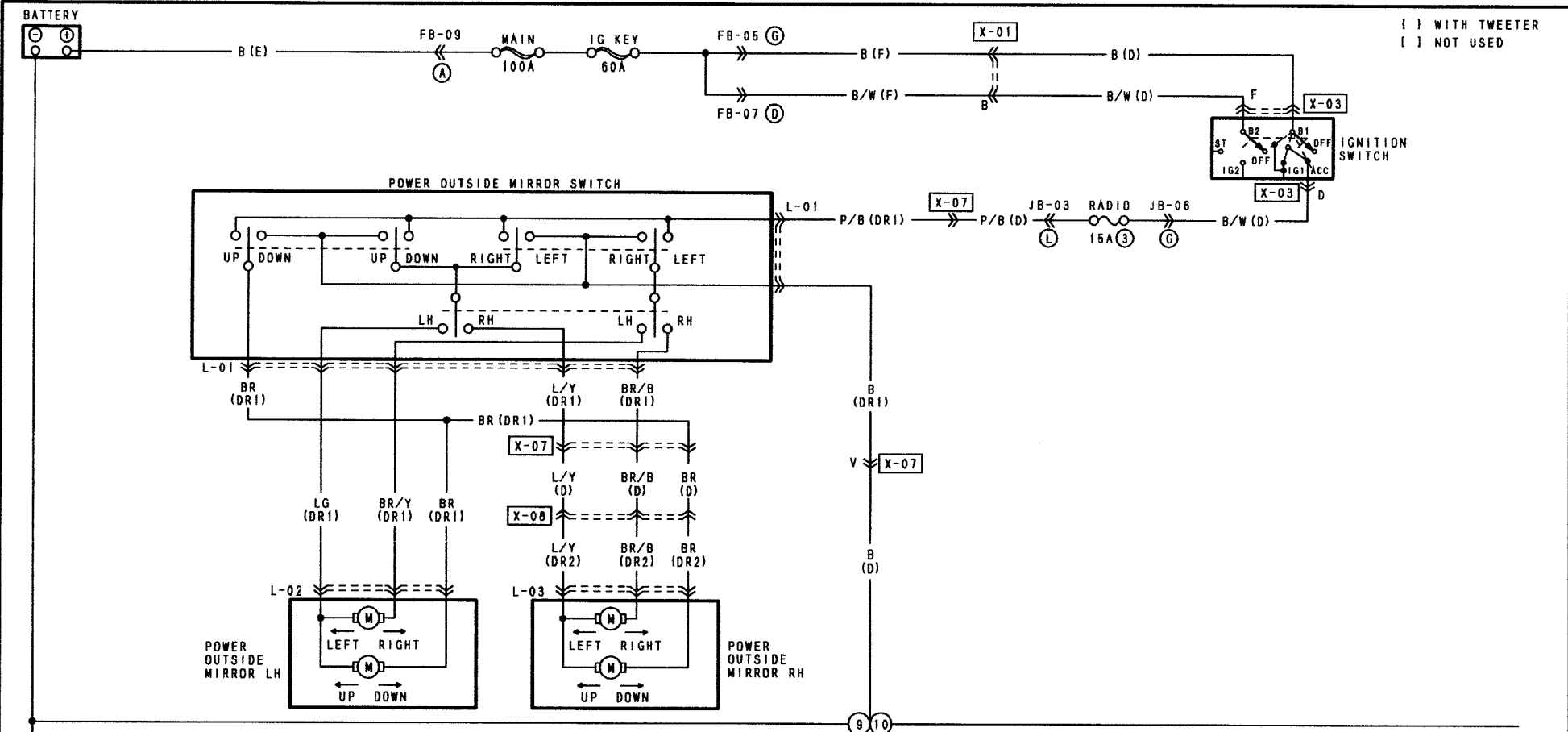

{ } WITH TWEETER  
[ ] NOT USED

TTT

L-01 POWER OUTSIDE MIRROR SWITCH (DR1)

BR/B	BR	<del>LG</del>	*	*
BR/Y	L/Y	LG	P/B	B

L-02 POWER OUTSIDE MIRROR LH (DR1)

*	*	*	*
(B/R)	(B/W)	*	
BR	LG	BR/Y	*

L-03 POWER OUTSIDE MIRROR RH (DR2)

(V/R)	*	*	(B/O)
BR	L/Y	BR/B	*

9 10

HARNESS SYMBOL :  (F)  (E)  (D)  (R)

59

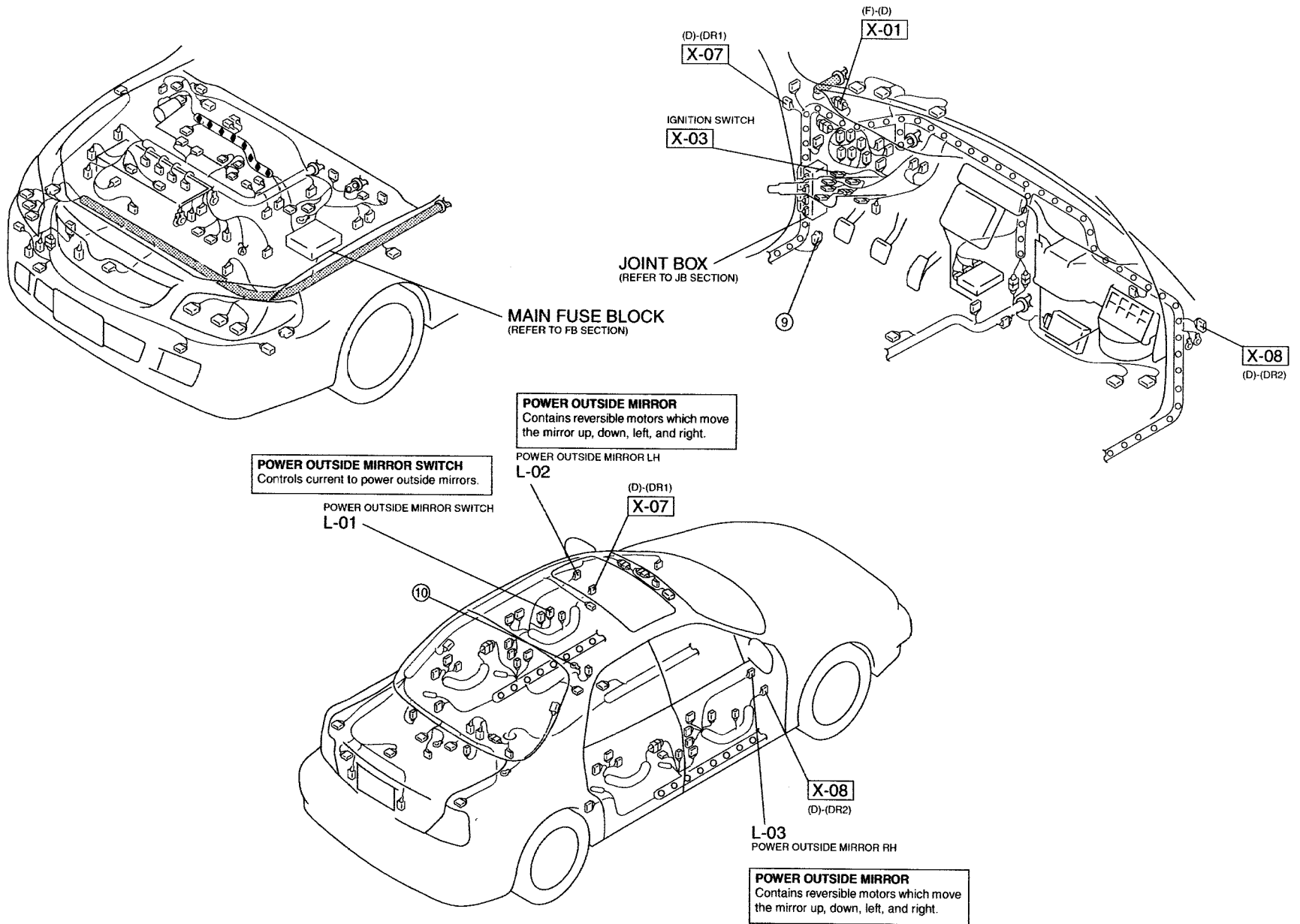

# DATA LINK CONNECTOR

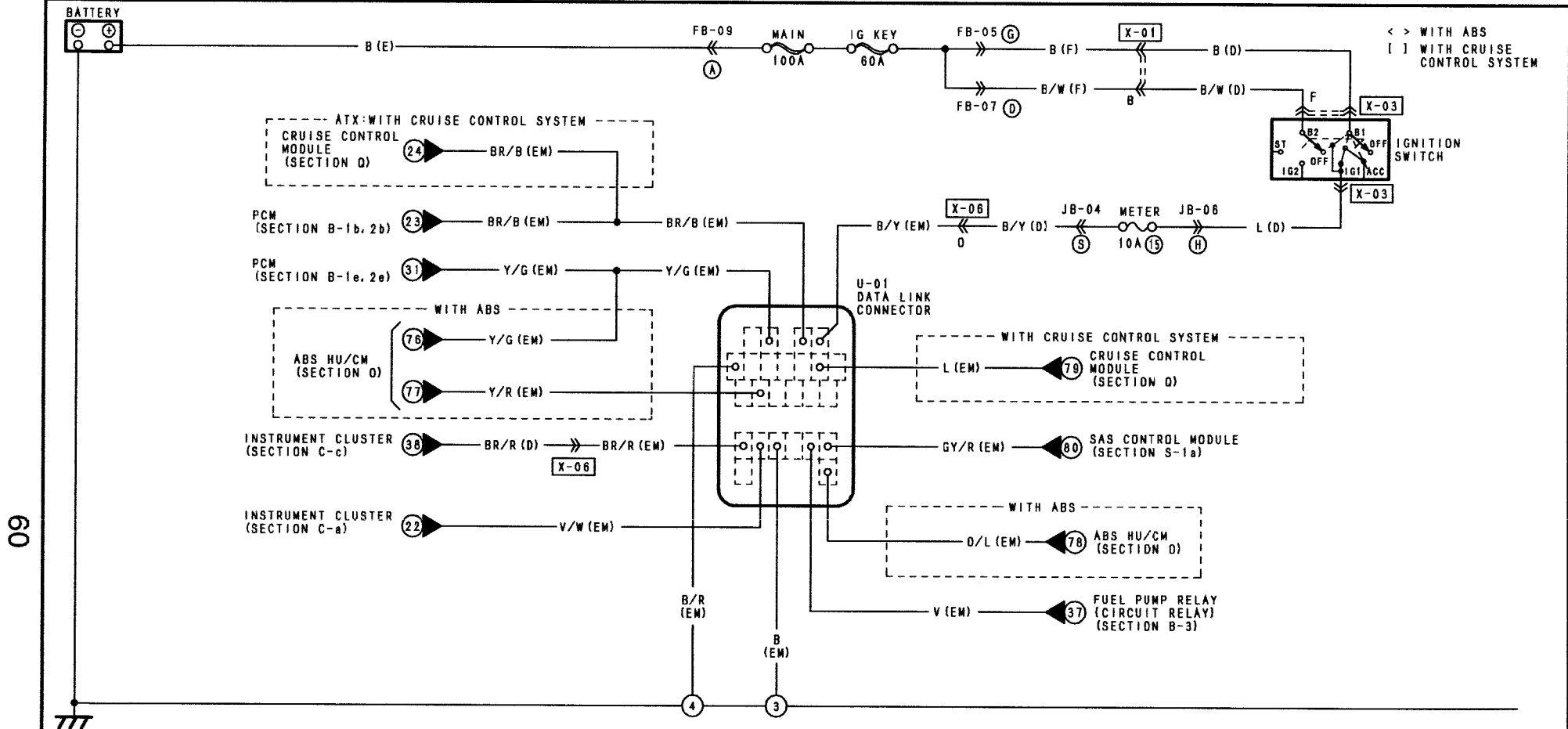

69

777

U-01 DATA LINK CONNECTOR (EM)

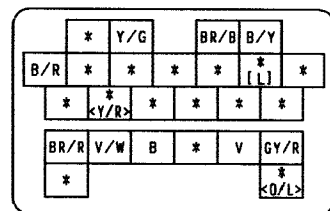
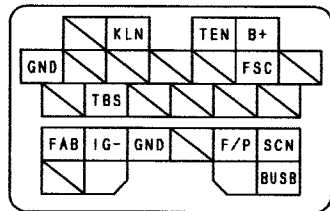

NOTE: THIS IS THE CONNECTOR AS SEEN FROM THE TERMINAL SIDE.

HARNESS SYMBOL :  (F)  (E)  (D)  (R)

61

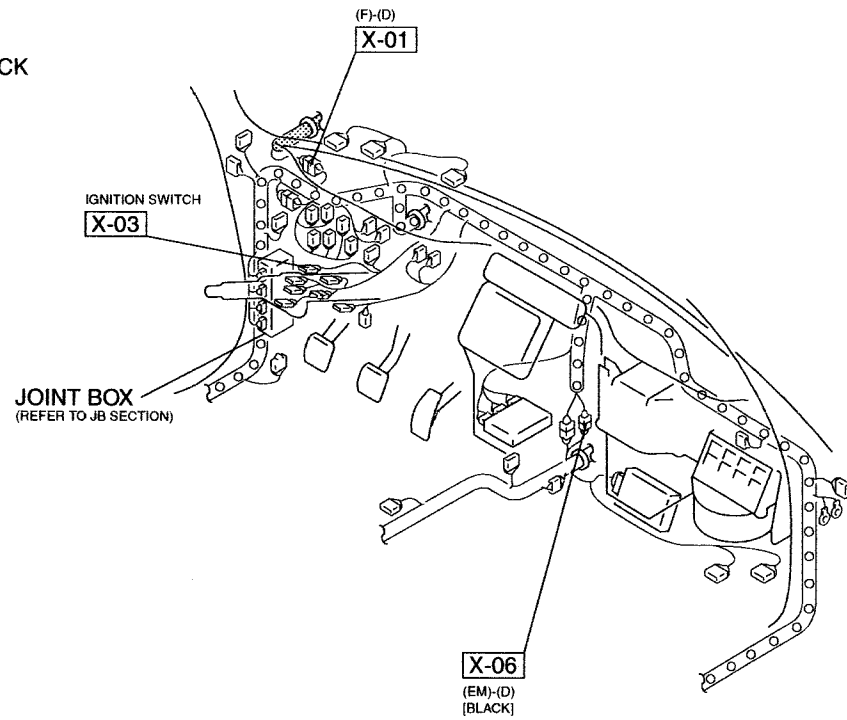
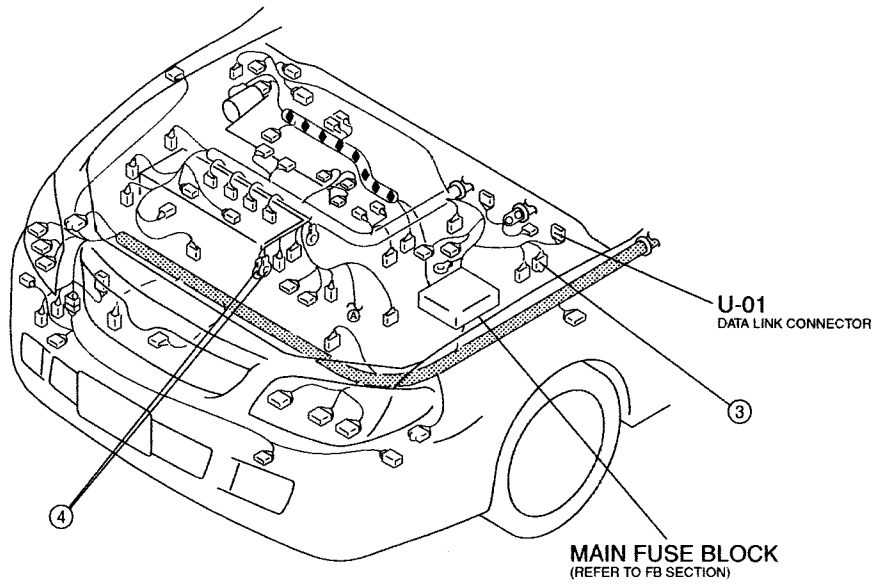

COMMON CONNECTOR LIST

X-01 FRONT (F) - DASH (D)

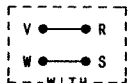
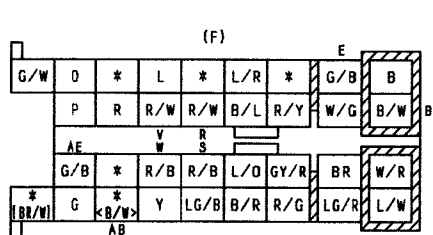

WITH VTCS SOLENOID VALVE

(4SD)

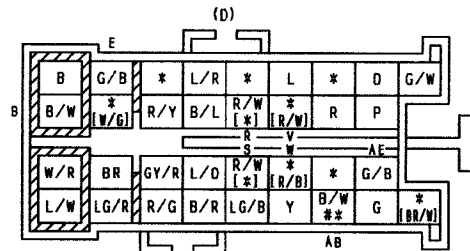

< > WITH VTCS SOLENOID VALVE  
[ ] WITH DRL  
#: SPORT AT

X-02 FRONT (F) - SHORT CORD

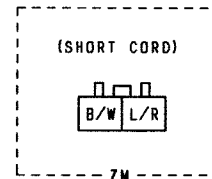
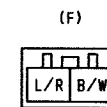

(4SD: WITH VTCS SOLENOID VALVE)

X-06 EMISSION (EM) - DASH (D)

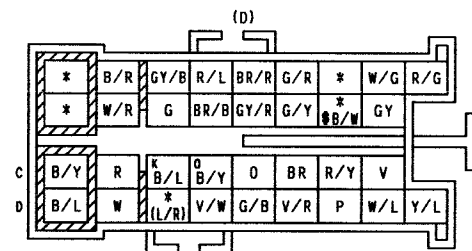
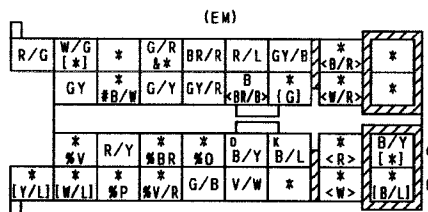

( ) MTX: WITHOUT ABS  
< > WITH ABS  
[ ] 4AT  
( ) NOT USED\* 4SD: WITHOUT DRL\*  
\*: WITH CRUISE CONTROL SYSTEM  
\$: 4SD  
#: ZM  
&: WITHOUT CRUISE CONTROL SYSTEM: 4AT

(EXCEPT SPORT AT)

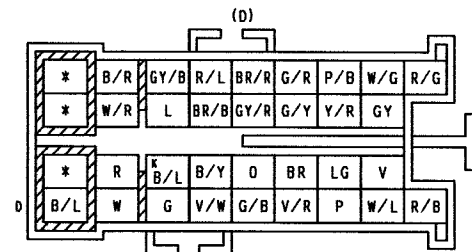
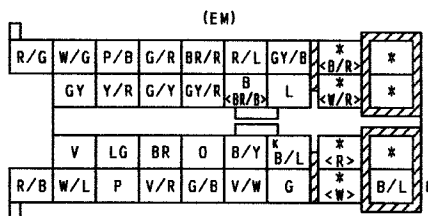

< > WITH ABS

(SPORT AT)

# COMMON CONNECTOR LIST

X-09 DASH (D) - DOOR NO. 3 (DR3)

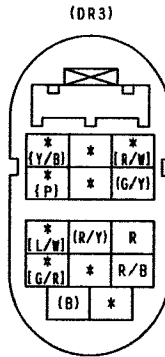
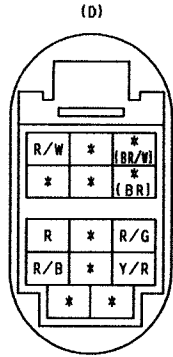

[ ] WITH POWER WINDOW SYSTEM  
 ( ) 5HB  
 ( ) NOT USED

X-10 DASH (D) - DOOR NO. 4 (DR4)

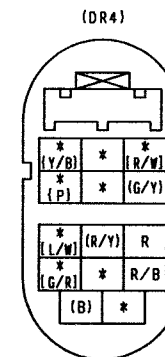
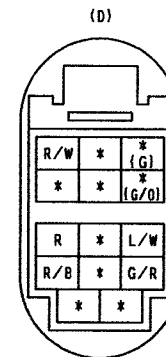

[ ] WITH POWER WINDOW SYSTEM  
 ( ) 5HB  
 ( ) NOT USED

X-13 EMISSION (EM) - SHORT CORD

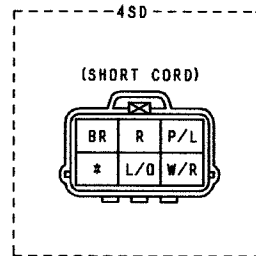
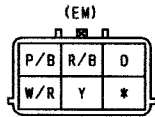

X-16 EMISSION (EM) - DASH (D)

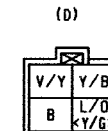
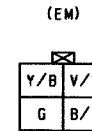

(EXCEPT SPORT AT)

< > WITH DRL

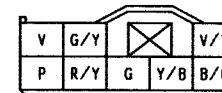

(SPORT AT)

< > WITH DRL

X-18 JOINT CONNECTOR (I)

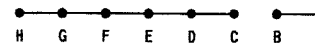
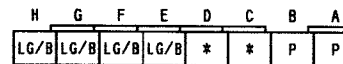

63

INTERCONNECTING DIAGRAM OF JOINT BOX

( ) NOT USED

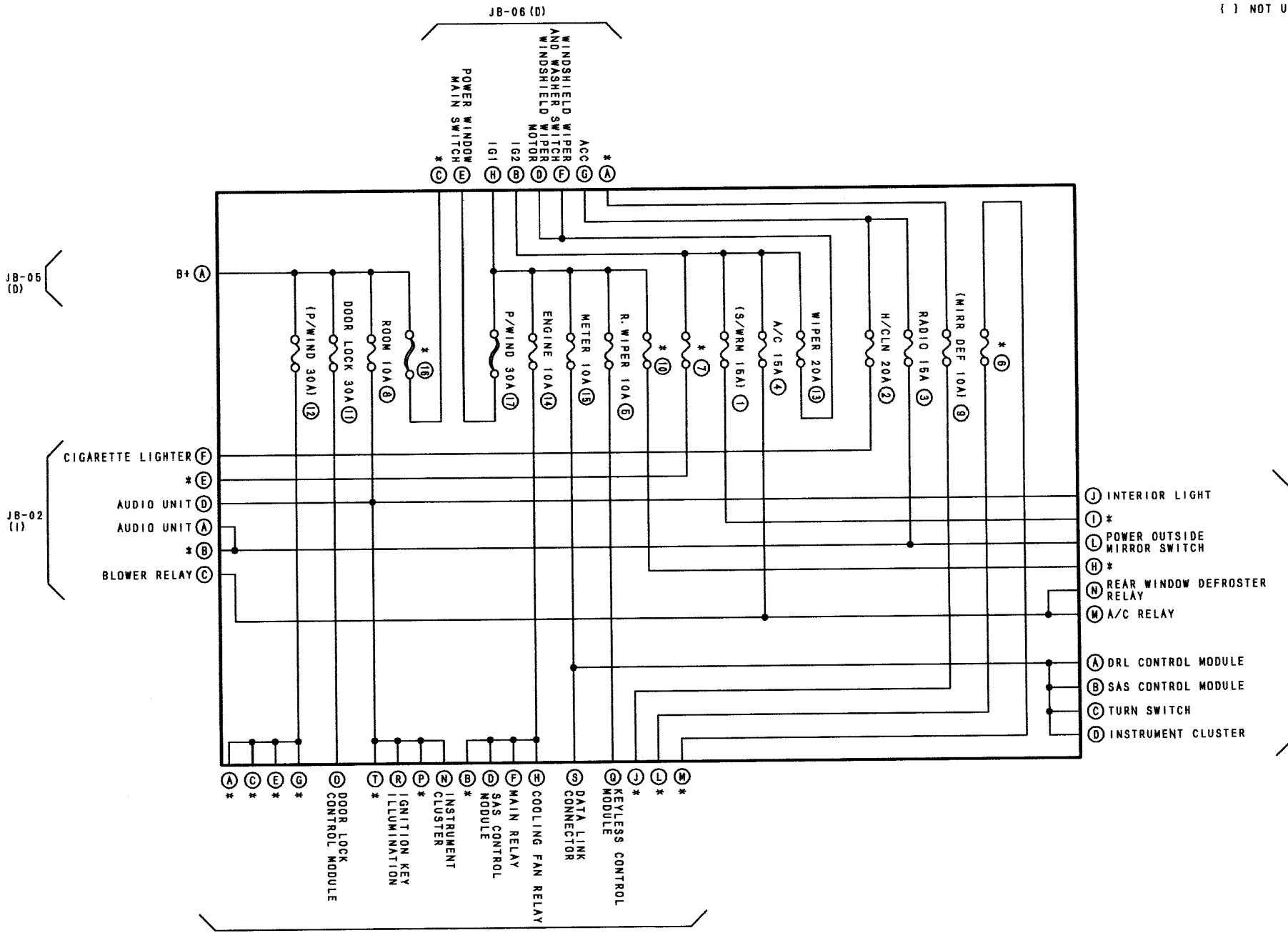

# JOINT BOX

JB-02 INSTRUMENT PANEL HARNESS (1)

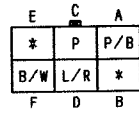

JB-03 DASH HARNESS (D)

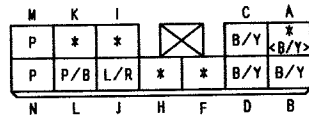

< > WITH DRL

JB-04 DASH HARNESS (D)

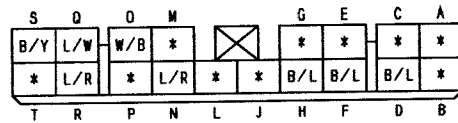

65

JB-05 DASH HARNESS (D)



JB-06 DASH HARNESS (D)

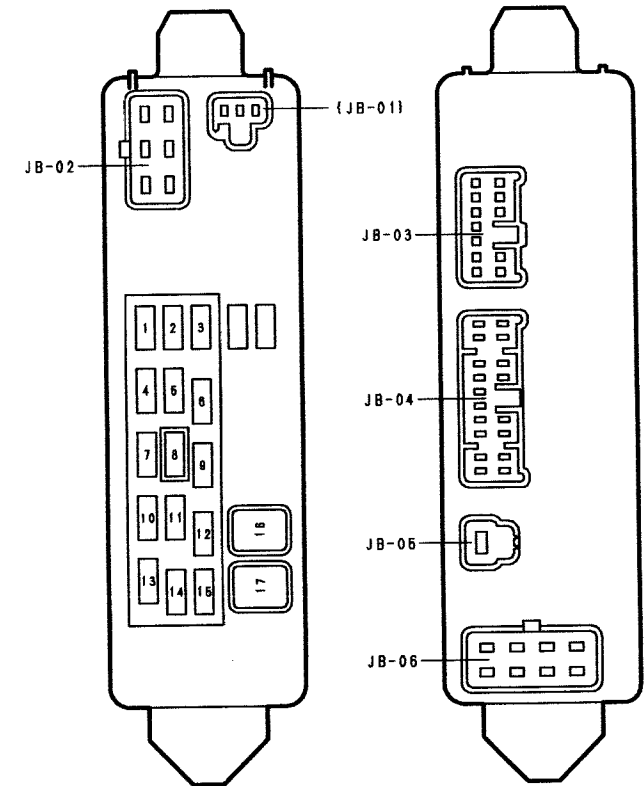
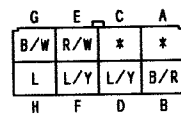

( ) NOT USED

NO.	CIRCUIT NAME	FUSE	NO.	CIRCUIT NAME	FUSE
1	{S/WRM}	{15A}	10	—	—
2	H/CLN	20A	11	DOOR LOCK	30A
3	RADIO	15A	12	{P/WIND}	{30A}
4	A/C	15A	13	WIPER	20A
5	R. WIPER	10A	14	ENGINE	10A
6	—	—	15	METER	10A
7	—	—	16	—	—
8	ROOM	10A	17	P/WIND	30A
9	{MIRR DEF}	{10A}			

JB



# INTERCONNECTING DIAGRAM OF FUSE BLOCK

FB

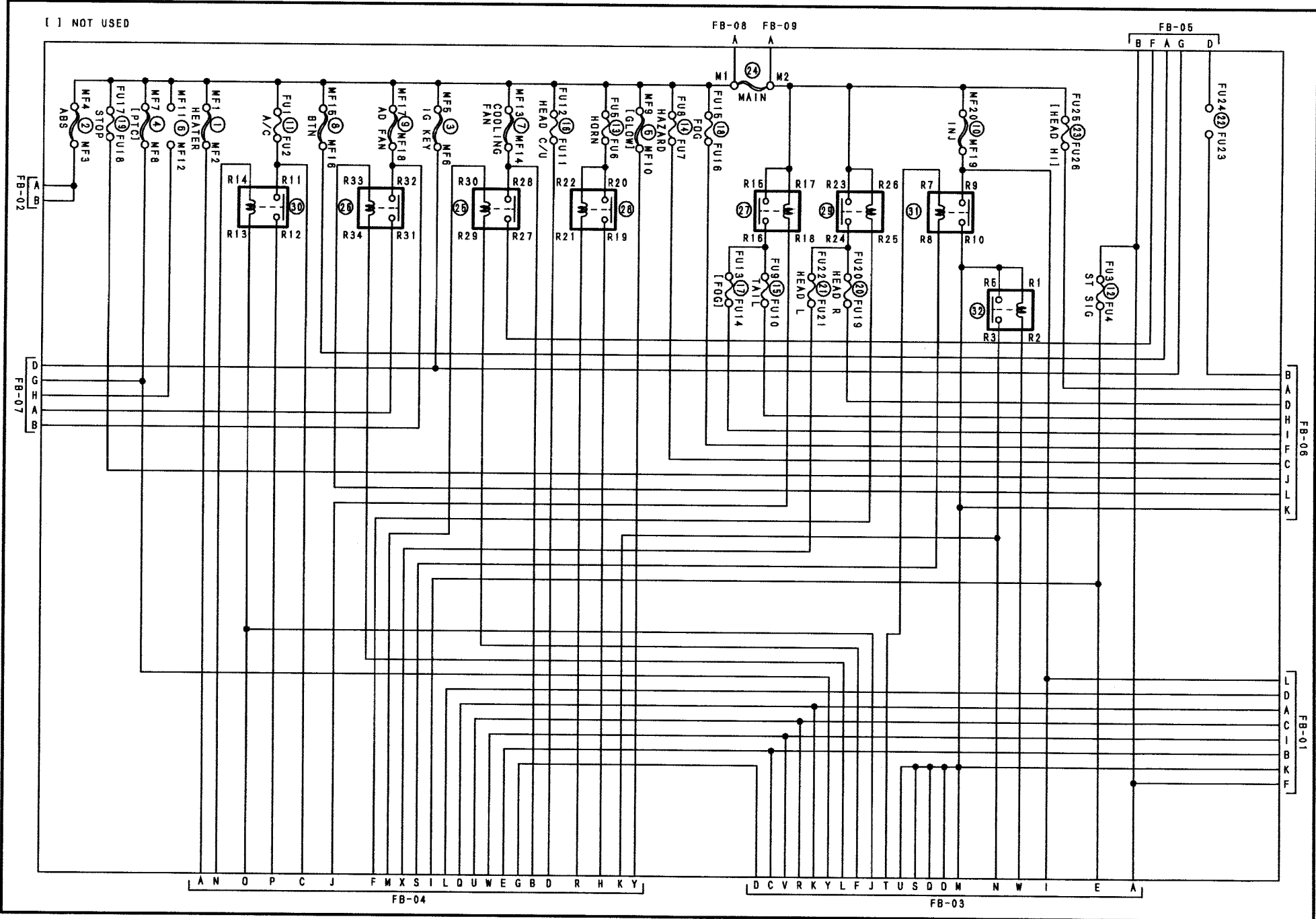

# FUSE BLOCK

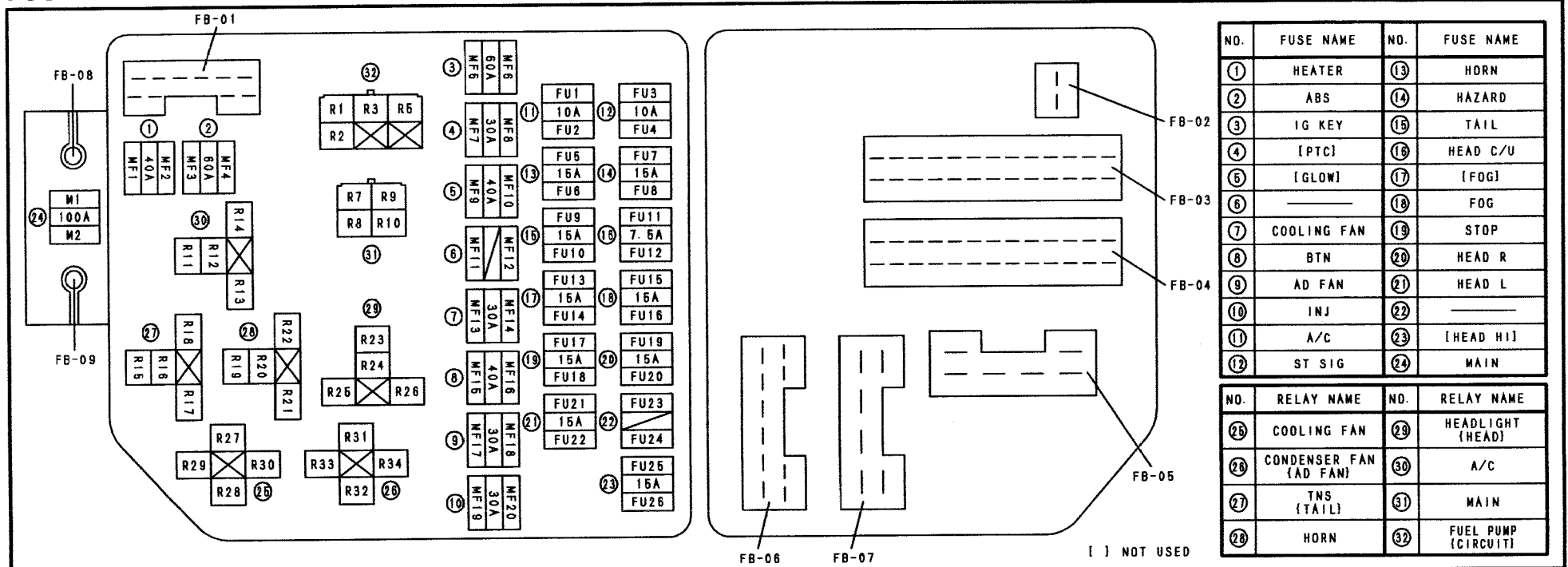

67

FB-01 ENGINE HARNESS (E)

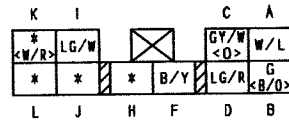

< > ATX

FB-02 EMISSION HARNESS (EM)

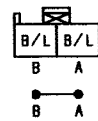

(WITH ABS)

FB-03 EMISSION HARNESS (EM)

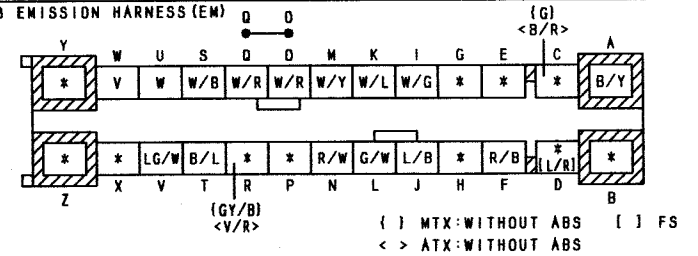

FB-04 FRONT HARNESS (F)

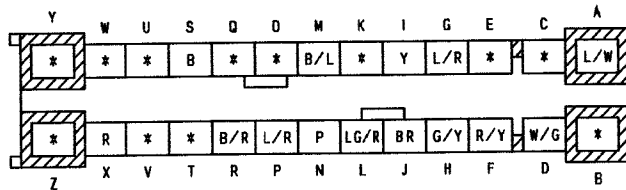

FB-05 FRONT HARNESS (F)

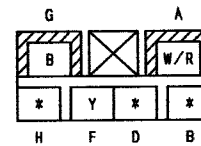

FB-06 FRONT HARNESS (F)

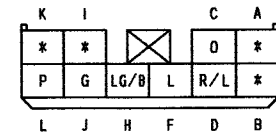

FB-07 FRONT HARNESS (F)

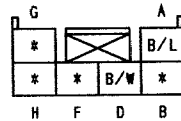

FB-08 ENGINE HARNESS (E)



FB-09 ENGINE HARNESS (E)



# PARTS INDEX

<b>A</b>	
A/C AMPLIFIER .....	44
AIR INTAKE ACTUATOR .....	44
AUDIO UNIT .....	54
<b>B</b>	
BACK-UP LIGHT .....	40
BACK-UP LIGHT SWITCH .....	40
BLOWER MOTOR .....	44
BLOWER RELAY .....	44
BRAKE FLUID LEVEL SENSOR .....	30
BRAKE LIGHT .....	42
BRAKE SWITCH .....	42
BUCKLE SWITCH .....	32
<b>C</b>	
CAMSHAFT POSITION SENSOR .....	10,24
CANISTER DRAIN CUT VALVE .....	10,20
CAPACITOR .....	8,18
CARGO COMPARTMENT LIGHT .....	48
CARGO COMPARTMENT LIGHT SWITCH .....	48
CIGARETTE LIGHTER .....	48
CLIMATE CONTROL UNIT .....	44
CLUTCH SWITCH .....	14,24
CRANKSHAFT POSITION SENSOR .....	14,24
<b>D</b>	
DATA LINK CONNECTOR .....	60
DATA LINK CONNECTOR-2 .....	16,26
DOOR SWITCH .....	30
<b>E</b>	
EC-AT SOLENOID .....	12,22
EGR BOOST SENSOR .....	16,26
EGR BOOST SENSOR SOLENOID VALVE .....	10,20
EGR VALVE .....	10,20
ENGINE COOLANT TEMPERATURE SENSOR .....	8,18
<b>F</b>	
FAN SWITCH .....	44
FILAMENT .....	48
FLASHER CONTROL MODULE .....	38
FRONT DOOR SPEAKER .....	54
FRONT FOG LIGHT .....	36
FRONT FOG LIGHT RELAY .....	36
FRONT FOG LIGHT SWITCH .....	36
FUEL INJECTOR .....	16,26
FUEL TANK PRESSURE SENSOR .....	16,26
<b>G</b>	
GENERATOR .....	6
<b>H</b>	
HAZARD WARNING SWITCH .....	38
HEATED OXYGEN SENSOR .....	8,18
HIGH-MOUNT BRAKE LIGHT .....	42
<b>I</b>	
IDLE AIR CONTROL VALVE .....	14,24
IGNITION COIL .....	8,18
<b>ILLUMINATION LIGHT</b>	
AUDIO UNIT .....	50
CLIMATE CONTROL UNIT .....	52
FRONT FOG LIGHT SWITCH .....	50
HAZARD WARNING SWITCH .....	50
IGNITION KEY .....	50
INSTRUMENT CLUSTER .....	52
O/D OFF SWITCH .....	52
SELECTOR LEVER COMPONENT .....	52
INPUT/TURBINE SPEED SENSOR .....	12,22
INSTRUMENT CLUSTER .....	28,30,32,34
INTAKE AIR TEMPERATURE SENSOR .....	26
<b>K</b>	
KEY REMINDER SWITCH .....	28
KNOCK SENSOR .....	24
<b>M</b>	
MASS AIR FLOW/ INTAKE AIR TEMPERATURE SENSOR .....	10
MASS AIR FLOW SENSOR .....	20
<b>N</b>	
NEUTRAL SWITCH .....	14,24
<b>O</b>	
O/D OFF SWITCH .....	12,22
OIL PRESSURE SWITCH .....	30
<b>P</b>	
PANEL LIGHT CONTROL SWITCH .....	50
PARKING BRAKE SWITCH .....	30
PCM .....	8,10,12,14,16,18,20,22,24,26
POWER OUTSIDE MIRROR .....	58
POWER OUTSIDE MIRROR SWITCH .....	58
POWER STEERING PRESSURE SWITCH .....	14,24
POWER WINDOW MAIN SWITCH .....	56
POWER WINDOW REGULATOR .....	56
POWER WINDOW SUBSWITCH .....	56
PRC SOLENOID VALVE .....	10,20
PURGE SOLENOID VALVE .....	10,20
<b>R</b>	
REAR DOOR SPEAKER .....	54
REAR PACKAGE SPEAKER .....	54
REAR WINDOW DEFROSTER RELAY .....	48
REFRIGERANT PRESSURE SWITCH .....	44
RESISTOR .....	44
<b>S</b>	
SELECTOR LEVER COMPONENT .....	46
SHIFT LOCK UNIT .....	46
SOLENOID VALVE .....	12,22
STARTER .....	6
STARTER INTERLOCK SWITCH .....	6

## PARTS INDEX

### T

THROTTLE POSITION SENSOR.....	16,26
TRANSAXLE RANGE SWITCH.....	6,12,22,46
TRUNK COMPARTMENT LIGHT.....	48
TRUNK COMPARTMENT LIGHT SWITCH.....	48
TURN AND HAZARD WARNING LIGHT.....	38
TURN SWITCH.....	38
TWEETER.....	54

### V

VEHICLE SPEED SENSOR.....	14,24
VEHICLE SPEEDOMETER SENSOR.....	28
VICS SOLENOID VALVE.....	20
VTCS SOLENOID VALVE.....	10,20

### W

WASHER FLUID-LEVEL SENSOR.....	32
--------------------------------	----